

6-1. INTRODUCTION.

a. GENERAL CONSIDERATIONS. — Electronic equipment which is designed to transmit and/or receive intelligence by wireless means must have an antenna or some other type of radiation or detection device to facilitate this accomplishment. The efficiency with which an antenna or detection device will function is, like the equipment itself, dependent upon proper design, construction, installation and maintenance. Nearly all such devices are installed in such a location as to be subjected to hazardous physical conditions such as weather, smoke pipe gasses and/or water pressure. It is very important therefore that proper installation standards be established and maintained, not only to insure satisfactory performance but also to facilitate preventive and corrective maintenance.

b. PURPOSE. — The purpose of this section is to describe the approved methods for the installation of antennas and other detection devices. The standards contained herein are intended to augment the installation procedures or instructions which may be contained in an individual equipment instruction manual as well as to provide information relative to the installation of antennas or detection devices which are adoptable for use with several different types or models of electronic equipment.

c. SCOPE. — Because of the great number of individual antenna types and systems in use it is not the intent of this section to describe the installation standards for any particular antenna type or system. The procedures described herein should be considered generally applicable to all installations. When deviation from standard installation is considered necessary due to peculiar circumstances or other requirements, such deviation will be noted on the installation plan for the antenna or system being installed.

d. REFERENCE DOCUMENTS. — The materials and installation methods described herein are governed by the following documents:

- (1) General Specifications for Ships of the United States Navy.
- (2) NAVSHIPS 900.121 (A) Chapter 2.
- (3) QQ-P-330 Phosphor Bronze.
- (4) MIL-S-17211 (Ships) Wire, electrical, radio antenna.
- (5) JAN-I-7 Insulators, glass bonded mica, radio.
- (6) JAN-I-8 Insulators, steatite, radio.
- (7) JAN-I-9 Insulators, glass, radio.
- (8) JAN-I-21 Insulators, procelain, radio.
- (9) MIL-B-994 (Ships) Brass, Naval.
- (10) MIL-B-16443 Bronze, manganese castings.
- (11) MIL-A-907 Antiseize compound, high temperature.
- (12) MIL-P-15931.

6-2. ANTENNAS.

a. **GENERAL.** — An antenna may be defined as a conductor or a system of conductors which is employed to radiate and/or absorb electromagnetic energy into and from the surrounding atmosphere. The various shapes and sizes of antennas in present use are governed by the purpose for which the antenna is to be used. While the various types of antennas may differ in size, shape and electrical characteristics, any antenna system has the following common features and requirements:

- (1) The radiating or absorbing element. (Dipoles, whips, long wire)
- (2) A transmission line which is connected between the element and the transmitter and /or receiver.
- (3) An impedance matching device to permit the maximum transfer of electromagnetic energy between the antenna and the transmitter or receiver.
- (4) Necessary masts, poles, and towers or other supporting devices together with the necessary guying or other reinforcement to support the antennas and transmission lines.
- (5) Necessary insulators to maintain the radiating or absorbing element above Radio Frequency (RF) ground potential.
- (6) Necessary hardware for rigging or securing the element in place.

b. **SHIPBOARD ANTENNA ORIENTATION.**

(1) **GENERAL.**—Because of variations in the ships superstructure it has been necessary to formulate antenna layout plans for each ship type. Modifications to such type plans are often required and authorized because of special top-side installations of other equipment or armament which is not common to the particular ship type. In the absence of authorized modifications to the ship type antenna layout plan, such plans will be followed. Re-routing of wire antennas and re-location of whip or dipole antennas is often necessary after the installation of extensive top-side structures. Plans for such re-routing or re-location will be made available to the installer when required.

(2) **RADIO ANTENNAS (WIRE).** —Wire antennas are suspended between fixed points of the ships superstructure such as mast yardarms, mast and/or smoke pipe outriggers, deck mounted antenna trunks or other specially designed superstructure fittings. It is the general practice to locate the receiving antennas in the forward section of the ship with the transmitting antennas located aft. This is done in order that the ships superstructure may act as an electronic shield between the transmitting and receiving antennas in an effort to eliminate or greatly reduce the effect of electromagnetic induction between them. All radio antennas must always be considered as a potential source of deadly electrical shock and must, therefore, be installed in such a manner that accidental personal contact with them is normally impossible. The spacing between two adjacent antennas or between an antenna and any metallic point of the ships structure must be such that antenna swaying caused by the roll or pitch of the ship would not cause contact.

(3) **RADIO ANTENNAS (WHIP).** —In shipboard radio antenna installations, whip type antennas are replacing many of the wire installations. The use of whip type antennas make a neater rigging and top-side appearance. Since whip antennas are normally self-supporting they may be installed in many locations aboard ship. They may be deck mounted, mounted on brackets secured to the dummy stack or mounted at suitable points on the superstructure. When a whip antenna is mounted on a dummy stack the stack may have to be reinforced to support the added weight and stress. It should be mounted near the top of the stack and clear it by at least two feet.

The whip must be mounted in a clear space since it is subject to a certain degree of swaying and must not be permitted to strike other objects. The installation of whip guys will serve to reduce swaying considerably.

Whips used for transmitting are generally mounted in the after section of the ship as in the case of wire transmitting antennas. Whips for receiving are generally mounted forward.

(4) **RADIO ANTENNAS SINGLE AND MULTI-ELEMENT ARRAYS.** —Antennas for use with UHF and VHF radio equipment are comparatively much smaller and lighter in weight than other antennas. They are generally installed at the highest available points on the masts, yardarms or superstructure. The positioning of these antennas is specified on the installation plans and must be strictly carried out, not primarily because of possible danger to personnel or contact with other metallic objects, but because of the effect of their location on the individual antenna performance. They must be secured firmly to avoid possible shifting of position of the radiating/absorbing element. These antennas are generally dual purpose units, that is, one antenna is used for both transmitting and receiving. They must not be installed so as to be in the radiation path of any radar antenna in order to avoid radar generated interference.

(5) **DIRECTIONAL ANTENNAS.** —Directional antennas such as those used with radar, countermeasures and direction finding equipment are usually an integral component of a particular equipment or system and must be installed in accordance with the instructions contained in the installation manual for that particular equipment. In many instances these antennas are large and heavy which will restrict their location to those section of the superstructure which will handle their weight but at which their sending or receiving beam patterns will not be obscured. In some installations the proper orientation of the pedestal with reference to the longitudinal center line of the ship is necessary. This requirement

will exist when the antenna is equipped with a mechanical stowing system or when the positioning of the ships head marker is not variable through 360°. When pedestal orientation is a special consideration the pedestal will be equipped with a center line marker which must be accurately matched with the longitudinal center line of the ship. When such ships center line marker is not immediately available the installer should request that it be established by proper means before mounting the pedestal.

6-3. Wire Antennas.

a. **MATERIALS USED.**—Shipboard wire antennas must be constructed and installed using materials which meet specified standards, as follows:

(1) **WIRE ROPE, 5/16 INCH.**— This wire shall be 6 x 19 phosphor bronze in accordance with composition "A", Federal Specification QQ-P-330. The wire shall have six (6) strands of nineteen (19) wires each, laid around a fiber core. (Refer to Navy Department specification 22 R 3i.)

(2) **WIRE, 7/#18.**—This wire shall be 7 strands of #18 phosphor bronze or silicon bronze wire, laid up to form one conductor. The conductor shall be tightly covered with a polyvinyl chloride insulation in accordance with MIL-W-17211 (SHIPS).

(3) **INSULATORS.**— The specifications for insulators will depend upon the material from which the insulator is fabricated as follows:

- (a) **PORCELAIN, RADIO.**—JAN-I-21.
- (b) **GLASS, RADIO.**—JAN-I-9.
- (c) **GLASS-BONDED-MICA, RADIO.**—JAN-I-7.
- (d) **STEATITE, RADIO.**—JAN-I-8.

(4) **WIRE ROPE CONNECTORS.**— These connectors are provided in two (2) sizes as follows:

- (a) **TYPE MX-1177/U.**—Used with 7/#18 wire.
- (b) **TYPE MX-1178/U.**— Used with 5/16-inch wire rope.

NOTE

The connectors shall be manufactured of manganese bronze in accordance with MIL-B-994(SHIPS).

(5) **CLAMPS.**—The clamps must be cast bronze in accordance with MIL-B-16443. They are available in standard stock for 45°, 90°, 135°, 180° and TEE for wire sizes 5/16-inch and 7/#18. Figure 3-1 illustrates clamp shapes. The clamps come complete with necessary split lock washers and hexagon head bronze nuts. Table 3-1 lists the various types and sizes of antenna clamps available.

TABLE 3-1. ANTENNA CLAMPS

TYPE OF CLAMP	NAVY TYPE NO. FOR	
	7/#18 WIRE	5/16" WIRE
135°	10678	10684
90°	10679	10685
45°	10680	10686
180°	10681*	10687*
180°	10682**	10688**
TEE	10683	10689

*Has padeye on one side only

**Has padeye on both sides.

(6) **TURNBUCKLES.**— Turnbuckles (illustrated in figure 3-2) are available in four (4) standard types as follows:

- (a) **TYPE MX-1176/U.**— For use with 5/16-inch wire rope. Turnbuckle has a clevis on each end.
- (b) **TYPE MX-1184/U.**— For use with 5/16-inch wire rope. Turnbuckle has a clevis on one end and a type MX-1178/U wire rope connector on the other end.
- (c) **TYPE MX-1180/U.**— For use with 7/#18 wire. Turnbuckle has a clevis on each end.
- (d) **TYPE MX-1179/U.**— For use with 7/#18 wire. Turnbuckle has a clevis on one end and a type MX-1177/U wire connector on the other end. The turnbuckles shall be manufactured of manganese bronze in accordance with MIL-B-994(SHIPS).

(7) **SHACKLES.**—Shackles shall be manufactured of case bronze in accordance with MIL-B-16443 and are available in two sizes as follows:

- (a) **5/16-INCH.**— For use with 5-inch and 10-inch strain insulators.
- (b) **7/16-INCH.**—For use with 15-inch and 20-inch strain insulators.

(8) **STAPLES AND PADEYES.**—The staples and padeyes required to attach the antenna to the mast or other points of suspension are usually fabricated of steel by the installing activity. The installer should insure that such staples and padeyes are properly secured and capable of withstanding the weight and strain of the antenna.

(9) **MISCELLANEOUS.**—Miscellaneous materials such as seizing wire, marlin and thimbles are standard stock items. Hand tools such as a hammer, wire cutter, hacksaw, combination pliers, drift punch, marlin spike and a bench-vice with copper lined jaws suitably mounted will also be required.

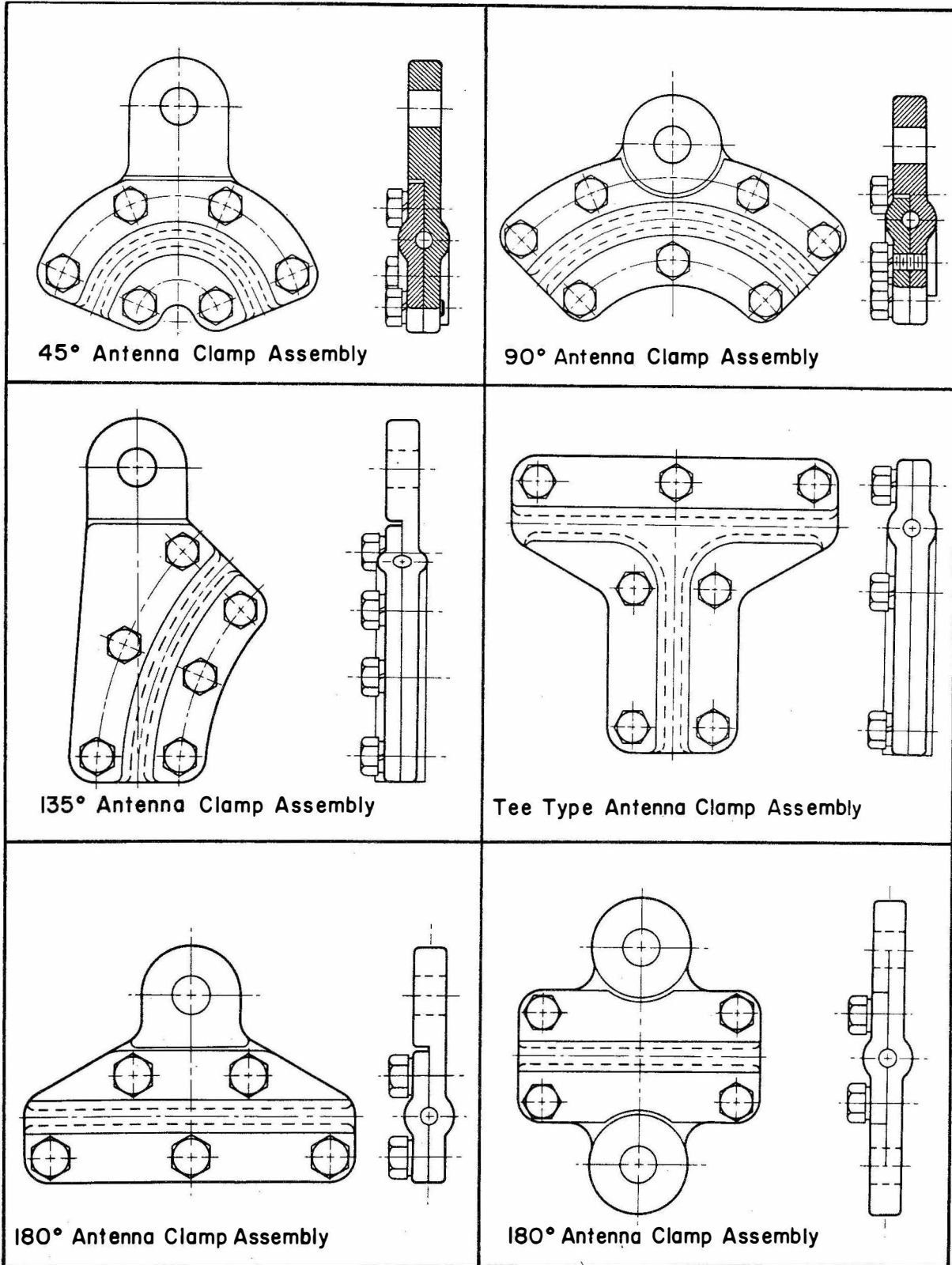

Figure 3-1. Antenna Clamp Shapes.

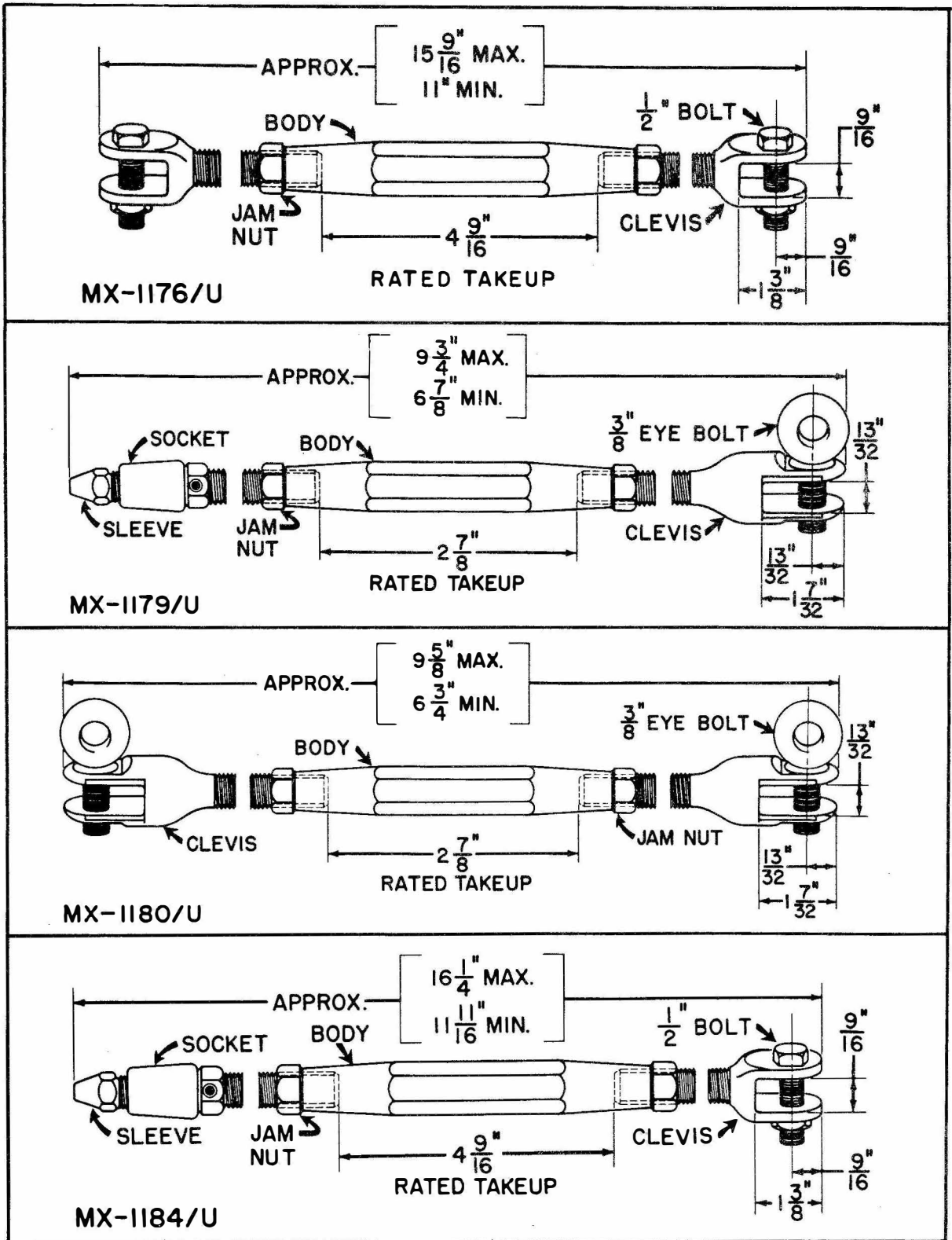

Figure 3-2. Turnbuckle Types

b. ANTENNA FABRICATION.

(1) GENERAL.—The following procedures are generally applicable to the fabrication of any wire or wire rope antenna:

(a) Obtain a print or drawing of the antenna to be fabricated.

(b) Obtain the necessary materials for fabricating the antenna. This information is normally contained on the drawing. Do not cut antenna wire to indicated length at this time.

(c) Select adequate working space and arrange antenna materials to the best working advantage. The working space must be such as to permit proper unreeling of antenna wire to avoid kinking. Hand tools and antenna fittings such as insulators, wire connectors, antenna clamps, turnbuckles and other accessories should be laid out on the work bench in an orderly fashion. Antenna wire reel should be properly mounted to permit easy unreeling of wire.

(2) ANTENNA LENGTH.—Determining the length of the antenna may sometimes be difficult. When the length is indicated on the drawing this indication may not be completely accurate due to necessary changes in antenna lead-in routing caused by superstructure changes not indicated on the drawing. Unless the antenna being fabricated is an exact replacement for an existing antenna so that the old one can be used as a template, the best and simplest procedure will be to actually measure the length by stringing a small line over the intended antenna path. This line should be hauled up to remove all the slack but it should not be stretched so as to give a false indication of length required. When the antenna being constructed is a "flat top" to be suspended between the masts the length given on the drawing may generally be accepted as accurate and the wire may be so cut without resorting to the above described measuring process. The reason being that the antenna can be shortened if it is too long and the down-haul or securing strap may be used to add the required length to the assembly if the antenna is cut too short. The lead-in from the flat top, however, will require more accurate measurement. When the proper length has been determined, unreel the wire as necessary preparatory to cutting.

(3) SEIZING AND CUTTING.—When using 7/#18 insulated antenna wire it is not generally considered necessary to seize the wire before cutting because the insulation will cause the wire to be held in proper shape and also it is reasonably easy to reshape if necessary. On the other hand the 6-strand 5/16-inch phosphor bronze wire rope should never be cut without first seizing the rope on both sides of the point at which the cut is to be made. Seizing may be accomplished either by applying electrical insulation tape along the wire rope for about two (2) inches and then making the cut through the tape so that both sides of the cut will remain seized after cutting, or by the use of seizing wire or marlin applied to both sides of the point at which the cut is to be made. When seizing wire or marlin is used the seizing should be applied in the following manner:

STEP 1.—Cut a piece of seizing wire or marlin about 12 or 13 inches long. This will be sufficient for the loop and about 9 or 10 turns around the 5/16-inch wire rope.

STEP 2.—Make a loop about 1 inch long with one end of the seizing material and lay it on the wire as shown in figure 3-3a.

STEP 3.—Wind about 10 turns tightly around the wire OVER this loop. At the last turn push the end of the seizing through that portion of the loop which extends from under the binding.

STEP 4.—Pull the seizing at the point one (figure 3-3a) until the loop is pulled almost under the binding. Check to insure that the seizing end which was pushed under the loop in step three is being drawn under the binding with the loop. Pull it only far enough so that the cross-over point (point one and two, figure 3-3b) will be at the center of the binding. Cut off those portions of the ends which extend from under the binding.

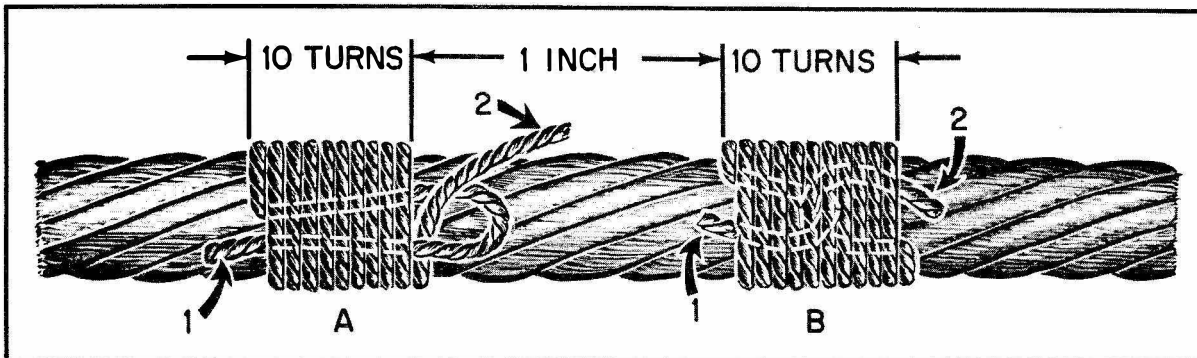

Figure 3-3. Seizing Wire Rope.

After the seizing has been applied to both sides of point at which the cut is to be made, cut the wire rope using a wire cutting tool or a sharp hacksaw, not less than 18 teeth per inch.

(4) WIRE CONNECTOR INSTALLATION ON 7/#18 WIRE. —The type MX-1177/U Wire connector (see figure 3-4) should be installed on the 7/#18 bronze wire as follows:

STEP 1.—Remove 1-5/16 inches of the polyvinyl insulation from the wire (see figure 3-5a).

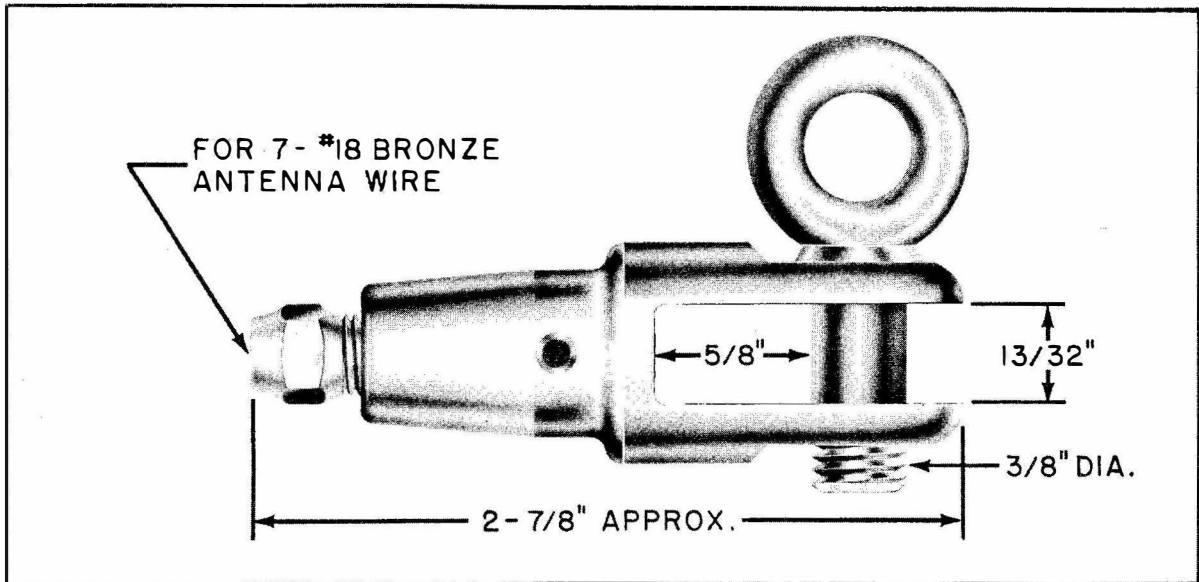

Figure 3-4. MX-1177/U Connector.

STEP 2.—Remove the sleeve from the body of the connector. Be careful not to lose the plug which is loose inside the sleeve. Place sleeve, plug and connector body on the bench beside the vise.

STEP 3.—Place antenna wire in the vise vertically so that the bare portion of the wire extends above the vise jaws.

STEP 4.—Slip the sleeve over the antenna wire (threads upward) and push it down so that the shoulder of the sleeve rests on the insulation and the vise jaws. There should be about 1/2 inch of wire extending above the sleeve.

STEP 5.—Untwist the extended wires with pliers. Continue untwisting until wires remaining in sleeve are free of the normal lay of the wire. Space the wires evenly around the sleeve inner walls and insert the plug in the center of the spaced wires (see figure 3-5b). Then, using a hammer and a drift punch, drive the plug down to a moderate seat sufficient to bind the strands, seat and sleeve firmly together.

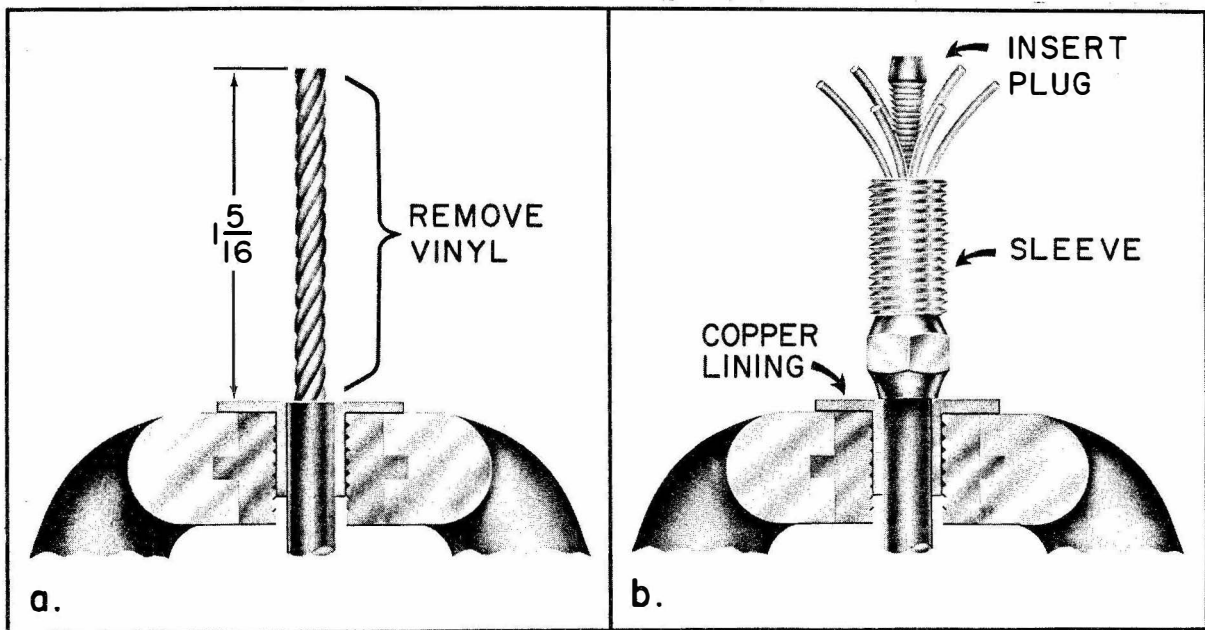

Figure 3-5. MX-1177/U Installation Details.

STEP 6.—Remove the wire from the vise and re-grip the assembly at the hexagon of the sleeve. Using the hammer and drift punch, drive the plug down into the sleeve as far as possible. During this operation it should be observed whether or not the wire is being driven out of the sleeve. This will be easy to see because there should be no ex-

posed wire below the sleeve shoulder. Should the plug driving operation force the wire out of the sleeve it is an indication that step 5 was not properly performed. When this condition occurs it will be necessary to force the wire back into the sleeve and then perform steps five and six again. To force the wire back into the sleeve it will be necessary to replace the wire in the vise as in step three and drive the sleeve back to its original position by screwing the body of the connector onto the sleeve two or three turns and gently tapping on the clevis end of the body, thus avoiding possible damage to the sleeve threads.

STEP 7.—When the plug has been driven into the sleeve as far as possible grasp the extending wires with the fingers and form them into a clockwise spiral pattern behind the plug (see figure 3-6a). Screw the body of the connector onto the sleeve and tighten down firmly. If the installation has been properly made there will be only one or two threads of the sleeve showing below the body of the connector, and the wires inside the connector will be at an angle to the axis of the wire and fitting, when viewed through the inspection hole in the body of the connector (see figure 3-6b).

(5) **WIRE ROPE CONNECTOR INSTALLATION ON 5/16-INCH WIRE ROPE.** - The type MX-1178/U wire rope connector (see figure 3-7) should be installed on the 5/16-inch bronze wire rope as follows:

STEP 1.—Apply a second seizing 2-3/4 inches from the end of the rope. Place the rope vertically in the vise over the seizing so that 2-3/4 inches extends above the vise jaws. Remove the seizing from the end of the rope.

STEP 2.—Disturb the lay of the six strands sufficiently to permit the extraction of about 2-1/2 inches of the fiber core. Pull the core out to one side between the strands and cut off 2-3/8 inches of it (see figure 3-8a). Then push the core stub back into the center of the lay. Do not disturb the lay anymore than necessary to accomplish the above. Reform the lay and seize lightly close to the end of the rope.

STEP 3.—Remove the sleeve from the connector. Be careful not to lose the plug which is loose inside the connector. Lay the plug and connector body conveniently beside the vise. Start the sleeve over the end of the rope (threads upwards) and slide it (turning with the lay as necessary) down to the light seizing close to the end.

STEP 4.—Remove the light seizing and slide the sleeve down until the sleeve collar rests on the vise jaws. There should be one inch of the wire strands extending above the threads.

STEP 5.—Before beginning to broom out the individual wires of the six strands separate the strands and insert a pointed steel pilot (a three inch nail of small diameter will serve nicely) into the fiber stub down inside the sleeve (see figure 3-8b). This will aid in locating the center of the rope after the wires have been broomed out. After the pilot has been put in place, "broom out" the wires of the individual strands. Be sure that the "brooming out" is carried well down inside the sleeve.

STEP 6.—Prior to removing the steel pilot, grasp the pilot on the end and move the end in a circular motion while holding the point in place. This action will serve to form a cone-like set in the "broomed" wires and thus establish the center for insertion of the plug.

STEP 7.—Remove the steel pilot and place the plug in the vacated space. With a hammer and a drift punch drive the plug down into the center with enough firmness to insure that the sleeve, wires and plug will be held firmly together.

STEP 8.—Remove the wire from the vise and re-grip the assembly at the sleeve hexagon section. Then drive the plug into the sleeve as far as possible.

STEP 9.—Form the extending wires into a pointed clockwise spiral behind the plug. Apply light seizing if necessary to assist in getting them all inside the barrel of the connector body. Remove the seizing and twist the barrel in a clockwise direction forcing it down to engage the sleeve threads. After the threads are engaged screw the connector body down firmly. If properly installed there will be only one or two sleeve threads visible below the connector body. Remove the seizing immediately below the connector. View the lay of the wires through the inspection hole. The wires should be twisted across the hole at an angle to the rope and the connector. Replace the screw in inspection hole if so equipped. Refer to figures 3-5 and 3-6 for similar details.

(6) **ANTENNA CLAMPS.**—Antenna clamps of appropriate types and sizes are used in the fabrication of all wire antennas. A "TEE" clamp is used when connecting an antenna lead-in to a flat-top antenna. An angular clamp of the appropriate type is used when it is necessary to change the direction of an antenna. A straight-line clamp (180°) is used when antenna support without change of direction is required. As previously indicated, all clamps must be made of cast bronze. This is required in order to insure continuity of the conducting wire or wire rope. The installer must insure that the antenna wire is installed to be fully in the grooves of the clamps to avoid unnecessary damage to the wire as well as to avoid reducing the over-all holding ability of the clamp.

(7) **ANTENNA TURNBUCKLES.**—Turnbuckles are used in wire antenna installations to take up any slack in the antenna wire which may develop after it has been pulled up taut. Figure 3-2 shows the details of construction of the turnbuckles used for this purpose. The installer must insure that the jam nuts are backed away from both ends of the turnbuckle body prior to attempting any adjustment of the turnbuckle. He must further insure that the jam nuts are tightened against both ends of the turnbuckle body after he has completed any necessary adjustment. These jam nuts, properly tightened, will prevent any undesired re-positioning of the turnbuckle body with attendant slackening of the antenna after the tightening process has been completed. The wire connectors (if any) on the turnbuckles are installed in the same manner as described previously in this paragraph.

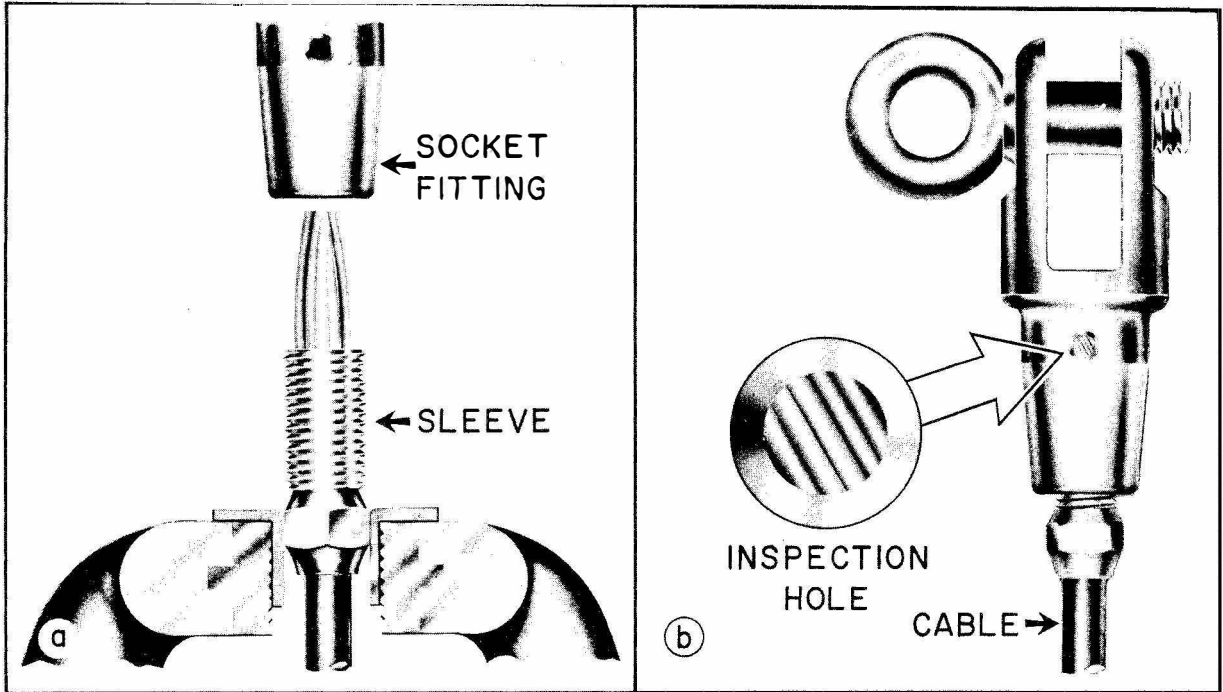

Figure 3-6. MX-1177/U Final Assembly.

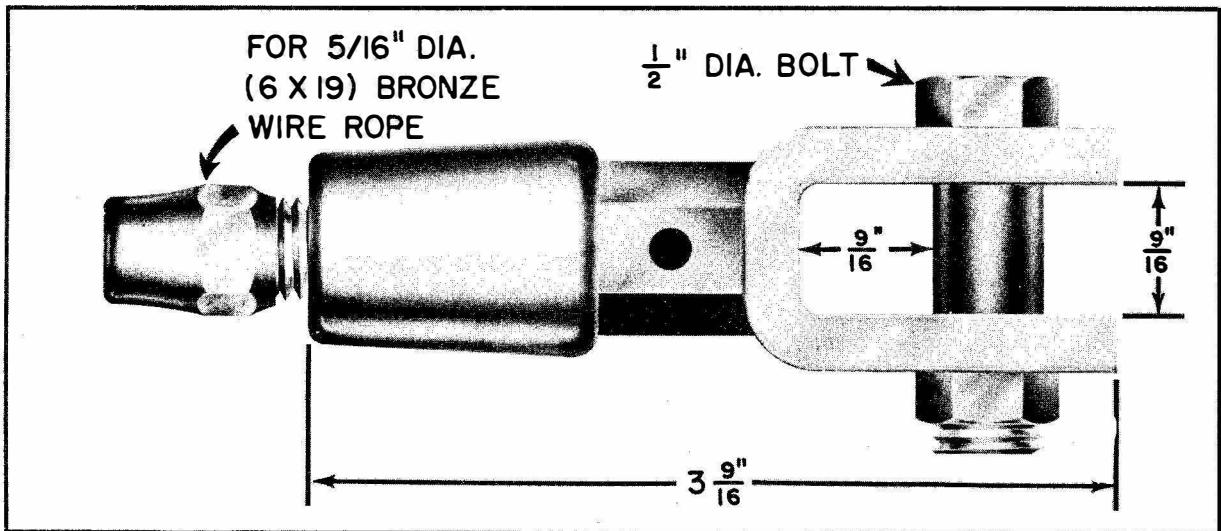

Figure 3-7. MX-1178/U Connector.

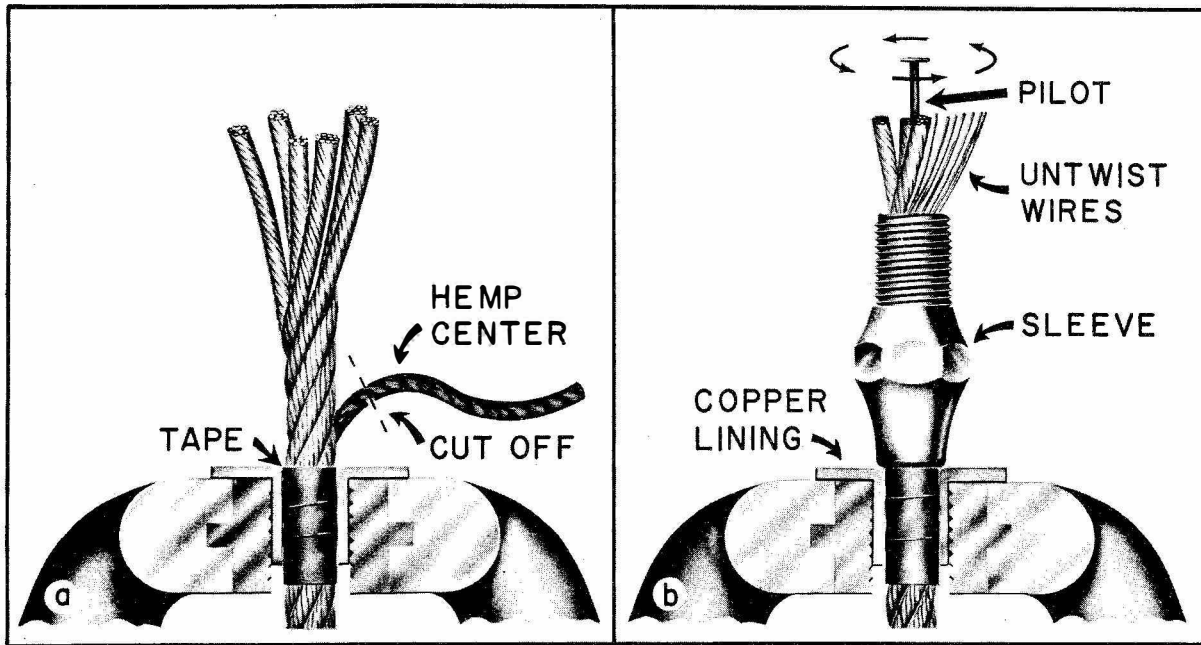

Figure 3-8. MX-1178/U Installation Details.

(8) SAFETY LINK ASSEMBLY. – A safety link assembly must be installed in all horizontal wire rope transmitting antennas which are rigged to stayed masts or structures. The safety link assembly is usually installed at the highest point of connection of the antenna to the mast or structure. The safety link itself is usually designed so that it has about 1/4 supporting strength of the wire rope used for the antenna.

The purpose of the safety link assembly is to prevent total falling of an antenna when the added strain of ice accumulation and/or whipping of the antenna wire would exceed the supporting strength of the antenna wire. Total falling of the antenna may endanger the lives of personnel due to electrical shock as well as falling objects. The safety link, being of lighter material than the antenna and the safety pendant, will break and allow the antenna to drop slightly to the point where the pendant will be put into use. This slight falling will immediately become visibly noticeable and it will be necessary to lower the antenna assembly to make the necessary repairs.

(a) Figure 3-9 illustrates the approved type of safety link assembly. This link assembly is fabricated in accordance with BUSHIPS Drawing No. RE-66-C-651 dated 10 June 1960. This drawing superceded BUSHIPS Drawing No. RE-66-F-648 dated 8 December 1959. A comparison of the above listed drawings will indicate the following major differences between them:

1. The type MX-1178/U wire connectors have been eliminated from both ends of the Safety Pendant and Eye Splices have been substituted therefore.
2. Galvanized steel shackles (7-16-inch) are used to connect the link and pendant to the superstructure padeye and to the antenna insulator.
3. The strain clams (Burndy type DUW-28 or equivalent) have been eliminated as unnecessary.
4. The Safety Pendant is looped and seized (as shown in figure 3-9) lightly to the Safety Link for orderly stowage.

(b) Table 3-2 identifies the items indicated by the encircled numbers in figure 3-9.

c. ANTENNA INSTALLATION.

(1) GENERAL. – The installation of a wire antenna consists generally of taking the fabricated antenna to the site of the installation; the rigging of necessary lines for hoisting it into position; the installation of the antenna suspension insulators; the hoisting and securing of the antenna into position and the connection of the antenna lead-in to the specified antenna truck or terminal. In some instances the antenna is actually fabricated at the installation site where measurements of required length are made by hoisting a partially fabricated antenna and then cutting it to proper length.

(2) INSULATOR INSTALLATION. – The type of insulator required at any given point of the antenna assembly is specified on the installation plan. The installer must exercise special care in the handling and installation of all insulators to insure that they are not damaged during the process of installation and that they are installed so as not to be subjected to any physical strain other than that for which they were designed. There are three (3) primary types of insulators used in the installation of wire antennas. They are:

(a) **STRAIN OR SUSPENSION.** - The Strain or Suspension insulator which is used to support the wire antenna as well as to isolate it from the ships structure. The following general instructions apply to the installation of strain insulators:

1. Using clevises and shackles the insulators must be installed to permit replacement when necessary without disturbing any served joints or wire connector installations.
2. Combining clevises and shackles where necessary to permit insulator motion in all directions required to avoid "binding" of an insulator end. Use of the clevis alone could restrict or bind the insulator and thus subject it to strain for which it was not designed. This strain would be caused by antenna swaying, which the insulator could not follow because of the bound end, and would thus be exposed to side whipping which may result in "snapping off" of the insulating material.
3. Using a combination of the Strain Insulator and an appropriate antenna clamp on antenna down leads or lead-ins in such a manner as to prevent any strain from being exerted against the feed-through studs of entrance insulators (see figure 3-10).

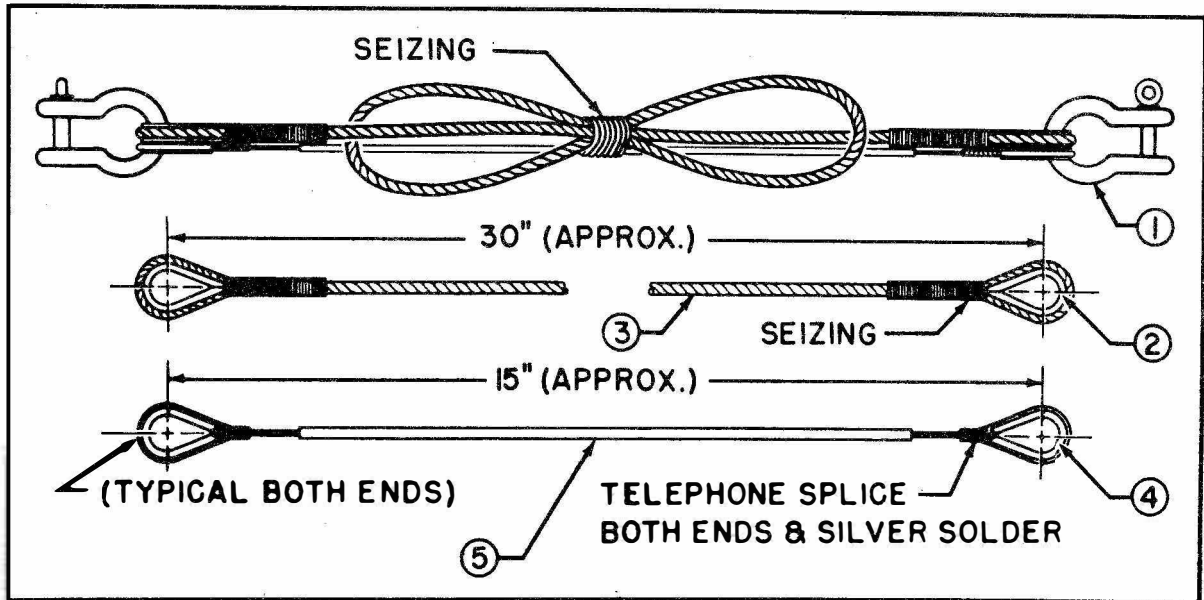

Figure 3-9. Safety Link Assembly.

TABLE 3-2. SAFETY LINK ASSEMBLY ITEMS (ONE LINK)

ITEM NO.	NAME OF PIECE	QUANTITY
1	7/16-inch Ga. Steel Shackle	2
2	5/16-inch Sil. Bronze Thimble	2
3	5/16-inch Phos. Bronze Wire Rope	1
4	3/16-inch Gal. Steel Thimble	2
5	7/#18 Covered Antenna Wire	1

(b) **STAND-OFF.** - The Stand-Off Insulator is a pedestal type insulator which is used to support un-insulated antenna lead-ins to prevent their touching the ships structure. They are primarily used to support a transmitting antenna bus within an antenna truck. The following general instructions apply to the installation of stand-off insulators:

1. They shall be mounted on soft rubber pads. The pad diameter shall be the same as that of the insulator base. The pad shall be 1/4-inch thick.
2. They shall be mounted using bolts, studs, or screws. Brazing or welding to the ships structure is not permitted.
3. They shall not be installed in locations exposed to the weather when used for antenna bus or wire supports.

(c) **ENTRANCE.** - The Entrance Insulator is a bowl shaped insulator which is used to provide an insulated path through a deck or bulkhead for the antenna bus. The type and size to be used will be specified on the installation plan. The following general instructions apply to the installation of Entrance Insulators:

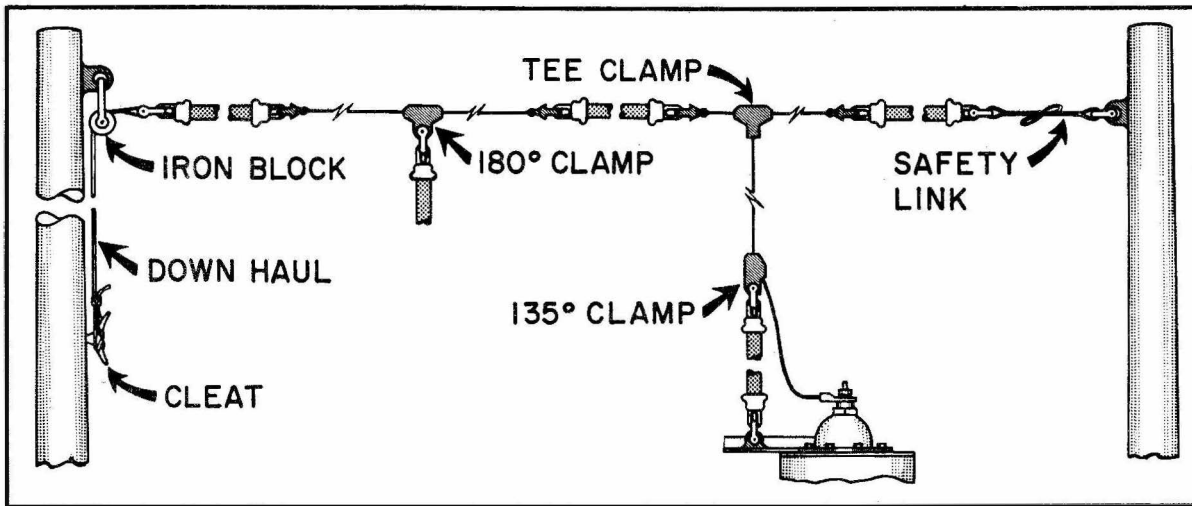

Figure 3-10. Wire Antenna Suspension.

1. When the insulator is to be **exposed to the weather** a corona shield **must** be installed.
2. When the insulator will not be **exposed to the weather** a corona shield **will not** be installed.
3. All insulators shall be installed so that accidental contact by personnel during normal activities would be high improbable.

4. Insulators shall be secured with bolts, studs or screws. Welding or brazing of the insulator holding ring to the ships structure is not permitted.

5. The use of approved gaskets both at the insulator base and at the feed-through hole is required where the installation is to be watertight.

(3) **HOISTING AND SECURING THE ANTENNA.**—There are several methods which may be employed for hoisting and securing the antenna. Some flat-top installations will have a permanent down-haul installed on one end. Others will use temporary down-hauls to hoist the antenna into position and then use straps made of wire rope to secure it. Vertical antennas may be installed between mast yardarms and deck mounted antenna trunks or they may be suspended from a flat-top using a "TEE" clamp and a strain insulator. Figure 3-10 illustrates examples of some of the commonly employed methods of suspending wire antennas. Following is a list of items which the installer should take into consideration as applicable to the hoisting and securing of any wire antenna:

- (a) Arrange the assembly so that it may be hoisted easily. Avoid the necessity for dodging guys and other rigging during hoisting operations.
- (b) Inspect all connectors, clamps, insulators and other fittings immediately prior to hoisting to insure mechanical soundness of the assembly.
- (c) Thoroughly clean all insulators of the assembly which will be suspended out of reach when the antenna is finally hoisted into place.
- (d) Hoist the assembly slowly to permit any necessary adjustment of fittings and wire to avoid any binding of kinks due to misalignment of fitting or wire.
- (e) When the system contains a Safety Link Assembly (as in a flat-top transmitting antenna) hoist the end containing the assembly and secure that end prior to hoisting the other end.
- (f) When a permanent down-haul is installed it shall be installed at the opposite end of the assembly from the Safety Link.
- (g) The down-haul should be secured to a clear installed for that purpose. After the down-haul has been fully belayed around the clear the down-haul end should be secured to the vertical down-haul by use of a cable clamp.

6-4. WHIP ANTENNAS.

a. GENERAL.—Whip antennas are commercially fabricated and are made in sections to facilitate crating and handling. In a 35-foot whip each section is about seven feet long and the sections at the top are of slightly smaller diameter than the lower sections. Each of the section ends is equipped with the necessary union fittings and threads for connecting the sections together. The installation of a whip antenna consists mainly of fabricating a mounting base, mounting the feed-through insulator, properly assembling the whip, mounting the whip on the insulator and connecting the antenna lead-in to the insulator feed-through bolt. When the installation of a tilting whip is required as in the case of a submarine or aircraft carrier installation, the mounting base must be designed to tilt in the desired direction and in the desired amount. There are several variations of design of the tilting mechanism, some are hand operated and others are motor driven, possibly a motor operated hydraulic mechanism. Each whip mount, whether stationary or tilting shall be installed in accordance with the installation plan specified.

b. WHIP ASSEMBLY.—When assembling the whip antenna it is strongly recommended that the threads of each connection joint be coated with Anti-Seizing Compound which meets the requirements of MIL-A-907 (SHIPS). This compound act to prevent corrosion at the connection joints and thus facilitates disassembly of the whip, if necessary for future repairs. Failure to use this compound invariably results in future inability to dis-assemble the whip thus making total replacement necessary, when only one or two sections of the whip would otherwise require replacement.

c. WHIP MOUNTING.

(1) STATIONARY WHIP. — The preferred method for mounting a stationary whip is shown in figure 4-1. The minimum size of the mounting platform and the line termination box will be determined by the type of base insulator to be used.

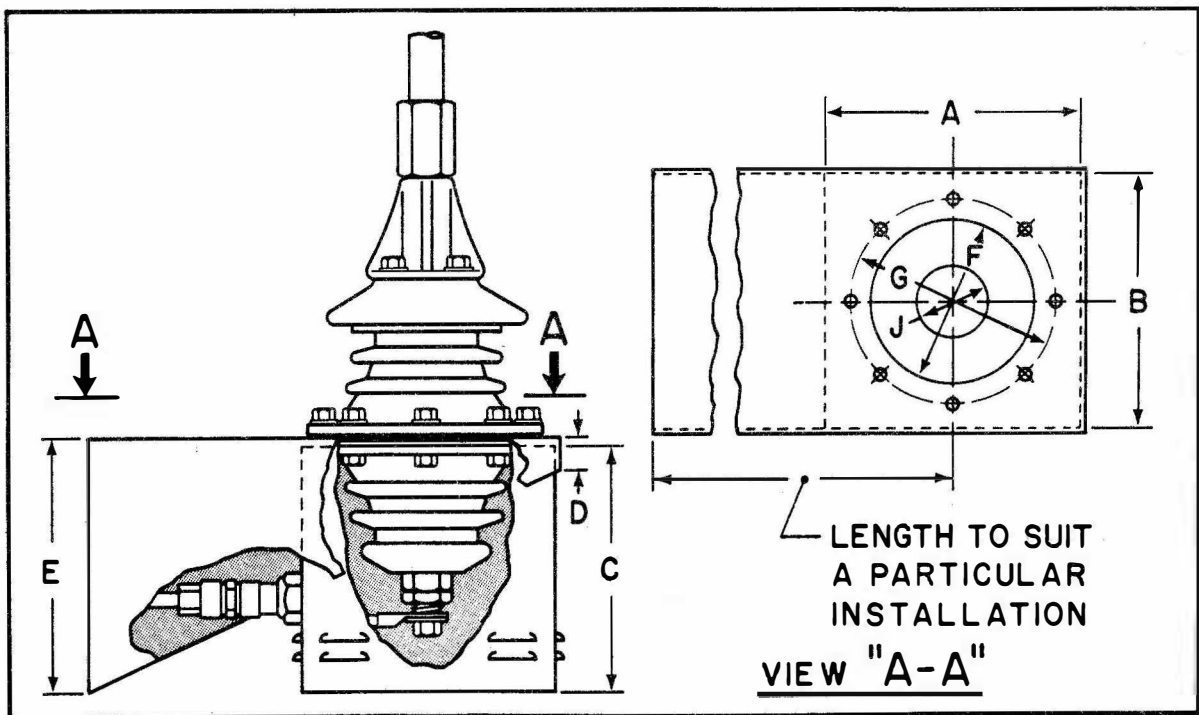

Figure 4-1. Stationary Whip.

Table 4-1 contains the dimensions (inches) for the mounting platform and the line terminal box with reference to figure 4-1. The mounting platform should be constructed to steel of sufficient strength to readily support the weight of the entire whip assembly. The Line Termination Box should be constructed to have louvers in its walls to prevent moisture condensation inside the box.

(a) The type 66046 and 66047 whip antennas are completely self-supporting when mounted as shown in figure 4-1. The 66053 whip requires additional bracing. An "A" frame about 3 feet high secured to the deck and having a type 61175A Stand-off Insulator secured at its top and clamped to the whip will serve as a satisfactory brace.

(b) The transmission line for the antenna is terminated in a cable end seal which is secured in the Line Termination Box as shown in figure 4-1. The end seal installation details are described and illustrated in section 5-5 of this chapter. The end seal is provided with the necessary lugs or fittings to ground the transmission line shield and armor inside the Line Termination Box. It is also equipped with a metallic cap to permit the connection of the inner conductor

TABLE 4-1. WHIP MOUNTING DIMENSIONS

WHIP TYPE NO.	INS TYPE NO.	LINE TERM. BOX (Inches)			FOUNDATION DIMENSIONS (Inches)						
		A	B	C	D	E	F	G	H	J	
66053	61428	10	10	10	2	10	2-1/2	5	(6)	9/16"D	2-1/4"D
66046 or 66047	61350	15	15	15	2	15	9-1/2	10-3/4	(8)	11/16"D	7" D
66046 or 66047	61335	18	18	18	2	18	13-1/8	14-5/8	(12)	11/16"D	11" D

of the transmission line to the antenna via the stud of the feed-through insulator. Use of 7/#18 insulated antenna wire with appropriate side lugs soldered at each end will serve nicely for this purpose.

(2) **TILTING WHIP.** - One method for installing a tilting mount for a whip antenna is shown in figure 4-2. This type of tilting mount is used for whip antenna installations on board aircraft carriers to permit the necessary positioning of the antennas during flight operations. Whip antennas are usually installed along the outer edge of the flight deck. Some ships may have tilting whips installed on the "island" superstructure. When installed along the outer edge of the flight deck the mount is oriented so that the whip will tilt out away from the ship. When installed on the island the the mount is oriented to tilt the whip aft unless the installation is made on the island front, in which case, the tilt should forward.

(a) The tilting mechanism shown in figure 4-2, for a 35-foot whip, consists of a stationary mounting frame which is welded to the ships structure, and a tilting platform which is mounted in bearings on the stationary frame. The platform is equipped with a handle or lever for positioning the platform to the desired degree of tilt. The mounting frame is equipped with a locking device which is affixed to the handle of the platform to secure the tilting mechanism when the antenna is in a vertical position, and with "stoppers" which prevent the platform from tilting further than desired. The amount of tilt is usually limited to 90° from the vertical position. The bearings on the stationary mount are equipped with grease fittings for lubrication of the assembly. The platform is equipped with a counterbalancing assembly which is adjustable to facilitate antenna tilting. When the counterbalancing weight is properly adjusted the antenna assembly should be capable of being tilted in any amount within its limits and of remaining in that position without the necessity of securing. There are no facilities for securing the assembly at any midpoints of the tilt since normally, full tilt or no tilt will be the desired position of the antenna.

(b) In the tilting whip installation the antenna Line Termination Box is normally mounted to be clear of the tilting assembly. The antenna lead-in from the termination box via a small entrance insulator. This lead-in should be installed when the antenna is in a vertical position to insure sufficient lead-in length. The use of insulated wire is recommended for this lead-in to avoid the possibility of its becoming grounded when the antenna is tilted. Unlike the stationary whip installation, the size of the Line Termination Box is not determined by the type of feed-through antenna insulator will be installed within the box.

(c) Where working conditions permit, the installer will find that it will be a much simpler operation to assemble the antenna and the platform with its counterbalancing mechanism, mount the entire assembly in a jury mounting frame and perform the balancing operation prior to taking the antenna to the ship for installation. Reasonably careful handling after the balancing operation will result in the condition of balance being maintained. The assembly may then be hoisted to the shipboard mounting platform and secured in place.

(3) **MONOPOLE ASSEMBLIES.** - The installation of this type of antenna is generally limited to large ships which have greater than average communications requirements. The monopole is a specially designed antenna system to provide more antenna efficiency for shipboard radio transmitting equipment consistent with the limited space available. When a monopole assembly is installed on board an aircraft carrier there exists the additional requirement for construction and installation of a tilting mechanism for it. Since the monopole assembly is a reasonably heavy unit the design and installation of the tilting mechanism is much more complex than for a simple whip mechanism.

There are several variations in the design of the monopole system. Each effort is being made to improve the design from the standpoints of efficiency, weight, space and cost considerations. Because of the variation in design it is not considered practicable to establish specific installation standards, however, there are several general standards which are considered applicable to all monopole assembly installations. They are:

(a) The assembly should be installed in the best possible location with reference to antenna radiation pattern and antenna ground plane.

(b) Strict observance of the design plans for the monopole assembly is of utmost importance both in the construction and the installation of the system.

(c) Use of the monopole structure to support other antennas or devices which are not a part of the assembly must be avoided.

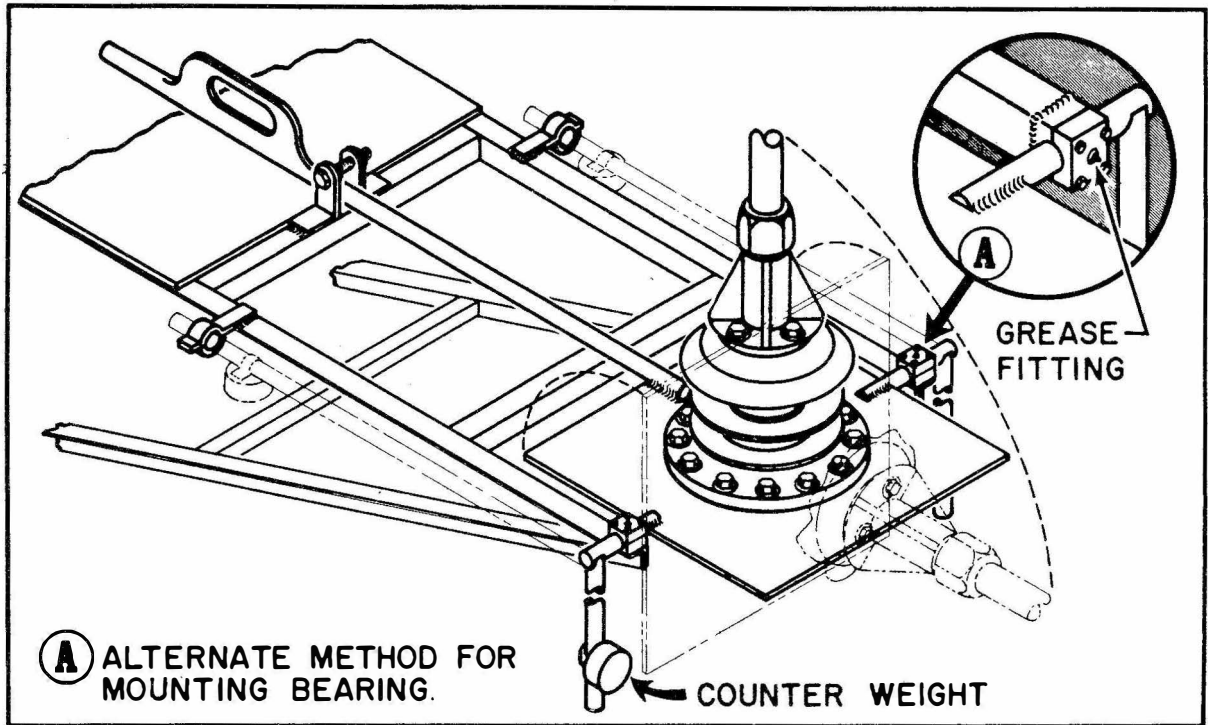

Figure 4-2. Tilting Whip.

(d) Substitution of materials in the construction or installation of the system should be avoided because of possible adverse effect upon the performance of the system

(e) The location of the assembly must be given consideration when installing other equipment or rigging in the general vicinity.

6-5. SINGLE AND MULTI-ELEMENT ARRAYS.

a. GENERAL.—Antennas of this type may be designed for a specific model of equipment or they may be designed for multiple equipment use. They are manufactured commercially and may be received by the installer in a disassembled condition. Instructions for assembly will accompany the antenna where necessary. Since this type antenna is used almost exclusively with equipment which operates in the VHF and UHF range they generally light in weight and comparatively small in size.

b. ASSEMBLING THE ARRAY.—When assembling the array it is very important to follow the manufacturers' instructions closely. Care must be exercised to ensure that no foreign matter is permitted to enter the array at points of connection. The connection joints must be carefully assembled and properly tightened to be watertight. The application of Anti-Seize Compound (MIL-A-907) to the threads of connection joints is recommended.

c. MOUNTING THE ARRAY.—After the antenna has been assembled, installation may be effectively accomplished by the observance of the following general rules:

- (1) Determine physical location of the antenna placement by consulting the installation plans.
- (2) Consult manufacturers instruction manual if available, to determine whether or not any special installation instructions or precautions are given.
- (3) Place the antenna at the position specified in the installation plan taking special notice of the positions of the radiating elements with respect to the mounting brackets or frame. The instructions should specify which elements should be positioned upward or forward. Two antennas may appear to be almost identical yet the positioning of their respective radiating elements may be exactly opposite.
- (4) Orient the mounting brackets properly and tighten them firmly to prevent any possible future shifting of the position of the assembly due to ships vibration, wind or other causes.
- (5) Install the proper coaxial fitting on the transmission line apply anti-seize compound to the threads and connect the fitting to the complimentary fitting on the antenna assembly. Exercise care to avoid sharp bends in the transmission line at the point of connection. If necessary, loosen adjacent cable clamp and move the transmission line in order to avoid a sharp bend for connection. Replace the cable clamp at a more advantageous point.
- (6) Tighten the coaxial fitting firmly. Apply plastic sealing compound to the outside of the coaxial connector unless otherwise directed.
- (7) When painting of the assembly is directed, apply masking tape or other suitable material to all insulators in the array to insure that they will not be painted. Remove the masking tape when painting is completed.

6-6. DIRECTIONAL ANTENNAS.

a. **GENERAL CONSIDERATIONS.**—Directional antennas are usually an integral component of a system and are manufactured commercially, either by the equipment manufacturer or at his direction. The size, shape, weight, electrical and mechanical characteristics of directional antennas are dependent upon the purpose for which the antenna is intended. A directional antenna assembly may weigh as little as fifty pounds or as much as ten tons. A similar degree of variation may exist in sizes and shapes of assemblies. A few antenna assemblies are equipped to afford antenna stabilization, that is, they are equipped with a tilting mechanism which is designed to maintain the antenna in a level position with respect to the horizon notwithstanding the pitch or roll of the ship (or both). They may be designed to rotate continuously in one direction or they may be equipped to permit rotation in either direction. Other features such as sector scanning, mechanical stowing are sometimes included in their design.

b. **INSTALLATION TECHNIQUES.**—The importance of proper installation of directional antennas cannot be over-emphasized. They are normally installed in locations which subject them to the hazards of high winds, rain, smoke pipe gasses, temperature extremes and also because of their location, comparatively poor maintenance schedules. Proper installation is therefore, of utmost importance. Because of the wide variations in design, the installation practices to be followed for any particular installation will not be covered in this section. There are a few general rules for these installations which may be considered as applicable to any directional antenna installation. They are:

(1) Study the equipment manufacturers instructions relative to handling, assembling and mounting of the antenna. These instructions are usually contained in a separate section of the equipment instruction manual entitled **INSTALLATION.**

(2) Prepare the mounting surface for the antenna pedestal. Drill all necessary mounting bolt holes and other accesses required. Exercise special care to insure that all holes and accesses are accurately positioned. Paint or otherwise preserve that part of the mounting surface which will be obscured after the pedestal has been put in place.

(3) Uncrate the equipment and check to insure that all installation hardware required for assembly and installation is available. Procure any installation hardware which is to be furnished by installing activity. Consult the equipment instruction manual for information.

(4) Assemble the system in accordance with the manufacturers instructions. These instructions are usually in the form of step by step procedures contained in the instruction manual. The manual also contains any special precautionary measures to be taken.

(5) Exercise extreme care in the fitting of coaxial and waveguide joints. Insure that any gasketing or packing is properly placed; that coaxial center conductor connections are properly made and that outer conductor unions or waveguide flanges are properly fitted and secured.

(6) When hoisting the assembly to its mounting surface insure that the rigging is properly accomplished. Do not use the lifting eyes on the reflector to sustain the pedestal weight. Do not attach rigging to any point which is not specifically designated for rigging and hoisting. Make certain that the hoisting slings do not place any strain on the reflector or the radiating elements.

(7) Insure that all pedestal mounting bolts are put in place and tightened firmly. Use bolts and nuts prescribed for the installation. Do not substitute these materials under any circumstances.

(8) Hand rotate the antenna assembly through the entire path of rotation to insure that it will not be obstructed by any rigging guys, halyards, hand-rails or other antennas. When the antenna is equipped with stabilizing features it must be hand rotated through the rotation path in both its upright and its tilted position to insure its being obstruction free.

(9) Observe manufacturers instructions concerning lubrication, oil levels and other special mechanical aspects of the system. Use only those lubricants which have been prescribed in the instruction manual.

(10) Be sure that any special tools which have been provided for the assembly are left with the assembly. Such tools should be turned over to responsible shipboard personnel upon completion of the installation.