

CHAPTER 13

MICROWAVE TECHNICAL CONTROL

13.1 VOICE ORDER WIRE

The average system requires one or more voice channels for maintenance communications purposes and to permit the transmission of various types of control data. One voice channel, connecting all stations with a responsible terminal station, is generally reserved for maintenance purposes. This channel is called the service, or order-wire, channel. In addition to providing a voice communication facility, the service channel, through the use of special equipment, may also be used for fault reporting (alarm) purposes and/or supervisory control functions. The fault alarm system permits operators at system control points to monitor the status of equipment at unattended stations; supervisory control circuits permit system operators to control remote functions.

13.2 SIGNALING (TERMINATION EQUIPMENT)

Termination equipment is required in radio relay systems to interconnect multiplex equipment and telephone equipment. The functions of such termination equipment will be described in this section, along with considerations that have to do with the use of standard telephone circuitry and facilities with radio relay equipment. The first consideration is that input signals applied to multiplex equipment and output signals from demultiplex equipment are limited to a frequency range of approximately 50 to 3500 Hz per channel. This frequency range is compatible with telephone equipment specifications for voice transmission; however, it is not compatible with telephone signaling requirements, since telephone signaling is normally accomplished by means of 20 Hz signals or DC pulses. Other considerations are those concerned with impedance matching, two-wire to four-wire transformation, and signal levels.

The basic functions performed by termination equipment are as follows: to transform two-wire telephone lines to four-wire multiplex lines, a pair for sending and a pair for receiving, and vice versa; and to convert DC or 20-Hz ringing voltages to voice-frequency signals, for transmission purposes, and vice versa. Because of the nature of the functions performed by the equipment, a more descriptive name such as Signaling and Terminating Equipment is also used. Industry standards for adapting microwave communication systems to telephone equipment are contained in Electronic Industries Association (EIA) Standard RS-210.

The number of signaling and terminating equipments required can be determined with ease, since one such equipment is used in conjunction with each voice channel being transmitted, and, likewise, one is used in conjunction with each voice channel being received. The telephone equipment required can be determined on the same basis if

only individual telephone sets are to be used. In more complex systems, the use of switchboards, extension phones, etc., may enter into these considerations. In describing the functional operation of typical signaling and terminating equipment, the presentation will be simplified by discussing the receiving and the transmitting functions separately. It should be remembered that only one voice channel will be considered, and that similar equipment will be used in conjunction with each of the other voice channels that work into or out of the multiplex equipment. A single telephone set is common to both functions.

13.2.1 Transmitting Function

The transmitting function of typical signaling and terminating equipment is shown in figure 13-1. To transmit a ringing signal, the operator causes the transmit relay to be energized or keyed by means of a telephone key or a telephone dial. As a result, a 3500-Hz signal is applied to the multiplex equipment by way of the relay contacts. The transmit filter prevents these signals from affecting other circuits shown to the left of it. When the operator speaks into the telephone, the voice signals are passed by the hybrid coil, the transmit pad, the limiters, and the transmit filter, and are applied to the multiplex equipment. The hybrid coil in this instance provides two-wire to four-wire transformation and impedance matching. The transmit pad, a variable attenuator, is provided to prevent abnormally high signal levels, possibly caused by shouting into the telephone, from exceeding the design limits for signal levels. The transmit filter removes any 3500-Hz components of the voice signal which might cause ringing to occur.

13.2.2 Receiving Function

The receiving function of typical signaling and terminating equipment is shown in figure 13-1. When a 3500-Hz ringing signal is received from the demultiplex equipment, it is applied to the receive filter. This filter permits the 3500-Hz signal to pass to the amplifier and detector, but not to the receive pad. The amplified and detected ringing signal energizes the receive relay, and, as a result, a 20-Hz signal source rings the telephone bell. When voice signals are received from the demultiplex equipment, they are passed by the receive filter to the receive pad, but not to the amplifier and detector. The receive pad is a variable attenuator which is adjusted to provide the desired signal level. The voice signals are applied, in turn, to the hybrid coil. The hybrid coil, common to both the receiving and the transmitting functions, provides impedance matching and four-wire to two-wire transformation. The voice signals from the hybrid coil are applied by way of relay contacts (of the unenergized receive relay) to the telephone receiver.

13.2.3 Interoffice Carrier Circuits

In many cases, the use of carrier or radio to provide the interoffice circuit precludes subscriber loop signaling methods. Usually some form of E and M signaling may be used. E and M signaling derived its name from arbitrary letter designations appearing on early circuit drawings for systems using this type signaling.

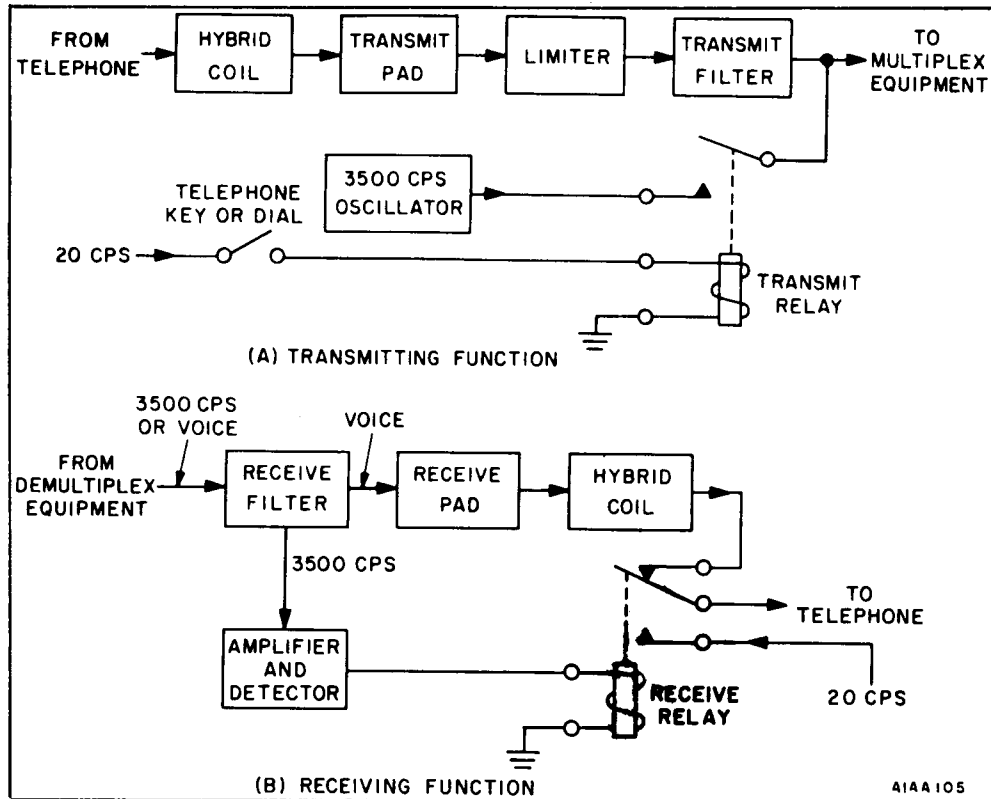

Figure 13-1. Functions of Signalling and Terminating Equipment

E and M signaling is characterized by the use of separate paths for the signaling and the voice signals. The M lead transmits ground or battery to the distant end of the circuit, while incoming signals are received as either a grounded or open condition on the E lead. With this method of signaling, the M lead reflects local conditions, while the E lead reflects the conditions existing at the far end of the circuit.

13.2.4 Signaling in Carrier (In-Band, Out-of-Band)

Some communications systems use separate channels to convey information used in controlling the operation of others. The communications industry considers it more economical and much more flexible if each channel carries its own signaling. In local telephone circuits, this can be achieved by direct currents which share the line with the signal voltages. In multi-channel carrier transmission, different techniques are required.

Voice channels occupy a bandwidth of 4-kHz. Some of this bandwidth is used for isolation from adjacent channels. The rest, usually about 3700 cycles, must carry both speech and signaling. In some cases, this channel bandwidth is used not only for voice, but also for one or more telegraph or teletypewriter circuits; these circuits are called speech-plus. These circuits must contain channel filters designed to prevent mutual interference between the speech, telegraph, and supervisory signals which share the channel.

In most carrier systems, one of three basic methods may be used for signaling: in-band, out-of-band, or separate channel signaling. Generally, separate-channel signaling is only used on very high density backbone routes or under special circumstances where signaling cannot be conveniently handled with the communications channels themselves.

The two most widely used signaling methods are called in-band and out-of-band methods. With out-of-band signaling, channel filters are designed with an upper cutoff frequency well below the top edge of the channel. This leaves a portion of the spectrum free to transmit signaling tones. Generally, a single tone is used and this is keyed to convey signaling information.

Some equipment takes advantage of the existence of a separate signaling channel above the voice frequency portion to perform other functions. In Lenkurt 45-class equipment, for example, two tones can be used. Signaling information is transmitted by alternations between the two tones. Since one or the other of the two tones is always present, it becomes possible to use the signaling tone as a reference pilot for regulating the individual channel level.

By completely separating signaling from the speech portion of the channel, it is possible to maintain relative freedom from mutual interference between the speech and the signaling tones; signaling tones can be transmitted during the conversation, thus permitting extra functions such as regulation.

In addition to being more flexible, out-of-band signaling can be much easier and more economical to accomplish, particularly if some sacrifice in channel bandwidth is allowed. In telephone circuits, there is very little speech energy present at the upper end of the channel. Accordingly, filtering requirements may be somewhat relaxed (telephone instrument weighting also provides a degree of filtering). This makes it possible to provide good quality transmission for relatively little equipment cost, since the greatest cost of carrier systems is in the channel filters.

One disadvantage of out-of-band signaling is that it requires some kind of DC repeater at the end of each link. That is, the signal pulses are detected and made to operate a relay. The relay, in turn, keys the signaling equipment in the succeeding link. Therefore, signaling terminals are required at both ends of each link. This has the disadvantage of increasing the cost, complexity, and possible distortion of the signals.

The use of in-band signaling appears to be a natural evolutionary step away from the use of separate channels for signaling. With in-band signaling, speech and signaling are intimately merged. Signaling tones are transmitted at a frequency within the

speech band, usually either 1600, 2400, or 2600 Hz. The principal objection to in-band signaling is that the signaling tones lie right in the speech band. This leads to the possibility that speech energy at the signaling frequency may be able to cause false signals with voice energy (called talk-down signaling). Conversely, signaling tones are audible and thus cannot be used during conversations.

The biggest advantage of in-band signaling is the extreme flexibility that it provides. The speech and supervisory signals share the same transmission facility, but at different times. The system is arranged so that supervisory signals are on the line only before or after a call. Since the signaling becomes a part of the transmission, it is not necessary to use DC repeaters. At branching points, a similar flexibility is obtained.

In-band signaling provides unusual flexibility and economy in large offices because it is then unnecessary to cable the E and M (receive and transmit) signaling leads through the office. The signaling equipment can be associated directly with the switching equipment, allowing a trunk circuit to be obtained from any available transmission medium, rather than being restricted to certain carrier systems.

13.2.5 Ringdown Signals

Ringdown signals are spurts of ringing current (16 to 25 Hz) applied usually through the ringing key of an operator and intended to operate a bell, ringer, or drop at the called end. The current may be generated by a manually operated magneto or by a ringing machine with or without automatically inserted silent periods. Ringing to telephone subscribers in automatic central offices is stopped or "tripped" automatically by relay action resulting from the subscriber's off-hook condition. Ringing signals may be converted to 500 or 1000 Hz, usually interrupted at a 20 Hz rate, to pass through voice channels of carrier equipment. A ringing signal to a manual switchboard usually lights a switchboard lamp, which can be darkened again only by local action and not by stopping or repeating the ringing signal. This characteristic makes ringdown operation unsuitable for fully automatic operation. Ringdown signaling over carrier circuits has the advantages of simplicity and of not requiring the distinct signaling channels of E and M systems.

13.3 SYSTEM ALARMS

In a typical microwave communications system, many of the repeater stations are designed for unattended operation. To ensure reliability of operation at these unattended locations, a fault-alarm system should be incorporated into the overall system design. The primary function of the fault-alarm system is to permit supervisory and operating personnel at the system control stations to monitor the operational status of the unattended locations. The fault-alarm system may be used to monitor the functional status of primary or standby microwave equipment, various accessory equipments, primary or standby power sources, or tower lighting circuits, or to provide illegal-entry alarm circuits for station buildings, site area, et cetera. Through the use of fault-alarm circuits, system outage time may be reduced to a minimum, since the type and

location of faults are immediately reported to the monitoring stations from which maintenance personnel may be dispatched. In addition, maintenance departments may be established at strategic locations, and personnel deployed more efficiently. The following paragraphs provide planning personnel with an insight to fault-alarm system design. A typical example of a basic fault-alarm system is also provided.

The number and type of faults to be monitored in a given system will vary, depending upon the length of the system, the number of unattended stations, and the degree of system reliability required. Therefore, a careful study of the proposed facilities must be made in order to determine individual needs. It is normal practice to monitor at least three functions from each unattended station. The functions normally monitored are: primary power failure or standby generator operation, primary RF equipment failure or standby RF equipment operation, and tower obstruction light failure. Other typical faults for which alarm facilities may be required are failure of multiplex equipment, illegal entry into station buildings or the site area, insufficient fuel levels in storage tanks for standby power generators, and excessive ambient operating temperature in station equipment building.

The number of monitoring stations required is dependent upon the overall system length, the number of unattended stations involved, and the number of fault-reporting circuits required. The monitoring stations may be located at the ends of the system (terminal stations) or at intermediate points (central terminal) throughout the system, as necessary to meet individual requirements. In long systems involving many hops, it is recommended that at least two monitoring stations be established, each equipped with maintenance communications facilities, and that they be located at opposite ends of the system. This arrangement prevents total loss of the fault-monitoring facilities due to operational failure within the system.

In any microwave system, the number of stations that may be equipped with fault-reporting facilities is limited by certain factors, the most significant of which are as follows: the number of multiplex voice-band channels allotted to the fault-alarm system, the usable bandwidth of the allotted channel or channels, and the frequency spacing required for individual fault tones. Although more than one voice-band channel may be used for fault-tone transmission, it is generally considered impracticable to use more than one unless absolutely necessary. For an average system using time-division multiplexing, the service channel (channel 1) will generally provide sufficient usable bandwidth for the transmission of the necessary fault tones. In systems employing frequency-division multiplexing, a portion of the microwave baseband is normally allocated to fault-reporting functions.

The allocation of specific fault-tone frequencies in a given system is governed by the requirements of the particular fault-alarm equipment used. A variety of equipments are available for use in fault-alarm applications; in general, the manufacturer's recommendations for the particular equipment selected should be followed when frequency assignments are made.

Each station from which faults are to be reported must be assigned a specific fault-tone frequency so that when faults occur, system operators at the monitoring stations

can easily determine which unattended station is reporting. As an example, consider the fault-tone frequency assignment plan used in a typical system employing time-division multiplexing. In this system, a portion of the service channel bandwidth (between 2.0 and 3.0 kHz) is allotted to fault-alarm functions, and fault-alarm equipment requiring 100-cycle spacing between individual fault tones is employed. It is evident that within the allotted bandwidth (1000 cycles) space is available for 11 separate fault tones, using the required spacing (2.0 kHz, 2.1 kHz, 2.2 kHz, etc.). Therefore, a separate fault-tone frequency may be assigned to a maximum of 11 stations. So that more than one fault may be reported on each assigned frequency, a simple coding device, such as a fault-interrupter panel, may be used at each assigned station. However, other types of systems provide an alarm which does not require a separate frequency per terminal. This type of alarm is particularly useful on large systems where the service channel frequency spectrum will not handle one discrete tone frequency per terminal.

If supervisory control functions are required in the system, a portion of the service channel bandwidth normally allotted to fault-alarm functions may be used for transmitting control data. This will reduce the number of frequencies available for fault-reporting purposes. When both fault-alarm and supervisory control data are transmitted simultaneously in the service channel, it is recommended that the higher frequencies be used for fault tones and the lower frequencies for control functions. If voice (maintenance) communications are also being accomplished on the service channel, the number of fault tones should be limited to six, located between 2.5 and 3.0 kHz to prevent mutual interference between the two functions.

13.3.1 Basic Fault-Alarm Equipment

The following paragraphs describe the functions and applications of the basic equipment used in typical fault-alarm systems.

13.3.2 Fault-Tone Transmitter

The fault-tone transmitter consists basically of a fixed-tuned tone generator and amplifier designed to operate within a specific frequency rate. The unit is normally installed at unattended stations from which fault conditions are to be reported. If more than one fault is to be reported, the fault-tone transmitter may be operated in conjunction with a keying device such as a fault-interrupter panel.

13.3.3 Fault-Tone Receiver

The fault-tone receiver consists of a highly sensitive fixed-tuned receiver designed to detect the fault tones generated by the fault-tone transmitter, and to operate fault-indicating devices. This unit is normally installed at monitoring stations. One receiver is required for each unattended station which is monitored.

13.3.4 Duplex Signaling Unit

The duplex signaling unit consists of a fault-tone transmitter and a fault-tone receiver. This unit is designed for use in a duplex signaling system, for transmitting control data

and detecting fault signals on two-way audio channels. The unit may also be operated on a simplex basis, in which case only the transmitting portion is used at unattended stations, and the receiving portion at monitoring stations.

13.3.5 Fault-Interrupter Panel

The fault-interrupter panel is a keying device used in conjunction with fault-tone transmitting equipment to facilitate the transmission of more than one fault on a single fault-tone frequency. Two general types of fault-interrupter panels are available. One type is used in fault-alarm systems employing the tone-off method of fault reporting, and the other is used in systems employing the tone-on method. Figure 13-2 shows simplified schematics of the two types of panels.

Although the system applications of the tone-off (A) and tone-on (B) panels differ, the units are similar. Each unit consists of a set of motor-driven cams and contacts, and fault-interrupter relays, which are connected in series with the keying circuit of the fault-tone transmitter. Each cam has a different configuration, and, when activated, opens and closes its associated contacts at a different rate. The field coils of the fault-interrupter relays are connected via the external fault-sensing circuits to the power line, so that when a fault occurs, power is applied to the coil of the appropriate relay. When no faults are present, all relays and cam motors are de-energized, and the fault circuits remain in a stable state. When a fault occurs, power is applied to the coil of the appropriate fault-interrupter relay by means of the external fault-sensing circuit. When the relay is energized, it interrupts the continuity of the fault-tone keying circuit and applied power to the cam-drive motor. The fault-tone circuit is then completed and the fault-tone transmitter is keyed in accordance with the keying rate generated by the associated cam-operated contacts. Should more than one fault occur simultaneously, the coded signals for each fault follow each other in such a manner that all faults can be positively identified.

13.3.6 Fault-Light Panel

As the system monitoring station, the outputs of the fault receivers for the unattended stations are connected to a fault-light panel. A light is provided for each station from which faults are to be monitored, and each light panel is equipped with a buzzer. In the event of a failure (fault) at a station, the light on the panel associated with that station flashes on and off in a predetermined sequence, which serves to identify the particular fault. The buzzer on the light panel also sounds in synchronism with the light, thereby drawing immediate attention to the fault occurrence.

13.3.7 Filter Panel

Filter panels are required in alarm systems where the fault-tone channel is also used for voice communications (service, maintenance, etc.). The filter panel is used to separate the tone and voice frequencies, and must be selected to fit individual needs.

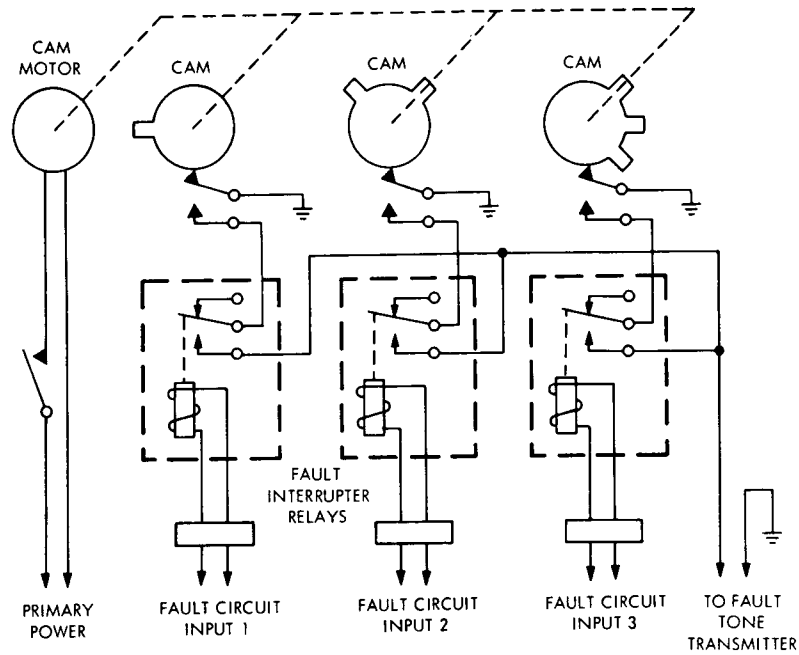

A. TONE OFF

NOTE:

MONITORED FUNCTIONS APPLY PRIMARY POWER TO FAULT INPUT CIRCUITS UNDER FAULT CONDITIONS

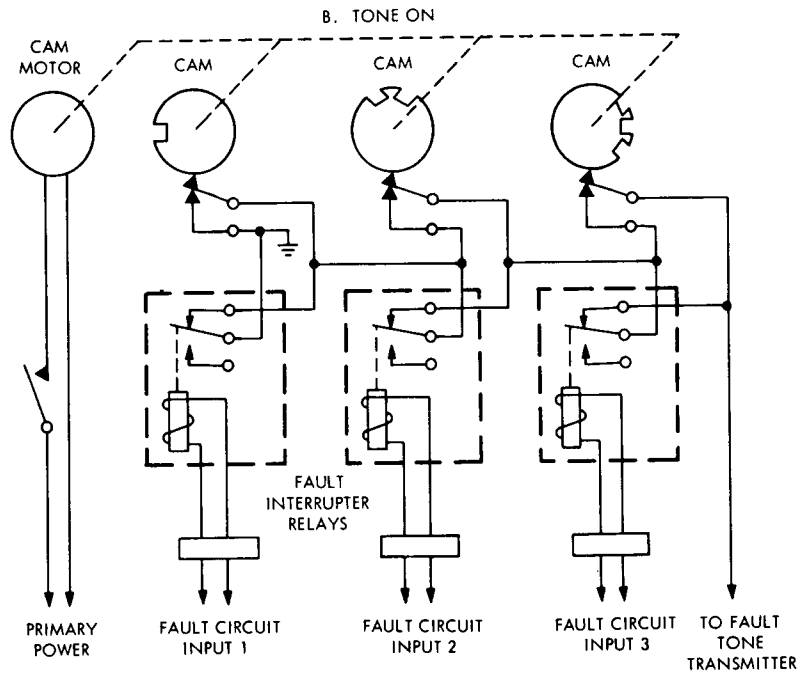

B. TONE ON

41A4108

Figure 13-2. Schematic Diagram of Tone-Off Type Fault Interruptor Panel (Sheet 1 of 2)

"This page purposely left blank"