

★  
**AURIE S. MYERS JR.**

**HANDBOOK OF MAINTENANCE  
INSTRUCTIONS**

AURIE S. MYERS, JR.  
1512 IVY LANE  
RALEIGH, N. C. 27609

*for*

**RADIO RECEIVING EQUIPMENT  
MODEL AN/APR-1  
*and*  
MODEL AN/SPR-1**

**RESTRICTED**  
(For Official Use Only)

**AURIE S. MYERS JR.**

★  
**APPROVED 15 JULY 1945**

Published under joint authority of the United States War and Navy  
Departments and the Air Council of the United Kingdom.

**SECURITY NOTICE**

*For U. S. Army Personnel:*

This document contains information affecting the national defense of the United States within the meaning of the Espionage Act, 50 U.S.C. 31 and 32, as amended. Its transmission or the revelation of its contents in any manner to an unauthorized person is prohibited by law. (AR 380-5) (ART 76, U.S.N. REGS-1920).

The information contained in restricted documents and the essential characteristics of restricted materiel will not be communicated to the public or to the press, but may be given to any person known to be in the service of the United States and to persons of undoubted loyalty and discretion who are cooperating in Government work.

*For British Personnel:*

For Official Use Only—Not to be communicated to anyone outside His Majesty's Service. Not to be published. The information given in this document is not to be communicated, either directly or indirectly, to the press or to any person not holding an official position in His Majesty's Service.

**LIST OF REVISED PAGES ISSUED**

NOTE: A heavy black vertical line, to the left of the text on revised pages, indicates the extent of the revision. This line is omitted where more than 50 percent of the page is revised.

**ADDITIONAL COPIES OF THIS PUBLICATION MAY BE OBTAINED AS FOLLOWS:**

**AAF ACTIVITIES.**—Submit requisitions to the Commanding General, Fairfield Air Service Command, Patterson Field, Fairfield, Ohio. Attention: Publications Distribution Branch, in accordance with AAF Regulation No. 5-9. Also, for details of Technical Order distribution, see T. O. No. 00-25-3.

**NAVY AIRCRAFT ACTIVITIES.**—Submit requests to the Chief, Bureau of Aeronautics, Navy Department, Washington 25, D. C.

**NAVY SHIP-SHORE ACTIVITIES.**—Submit requests NAVSHIPS 900, 483A to the nearest Radio Material Officer.

**BRITISH ACTIVITIES.**—Submit requirements on Form 294A, in duplicate, to the Air Publications and Forms Store, New College, Leadhall Lane, Harrogate, Yorkshire, England.

## TABLE OF CONTENTS

### SECTION I. GENERAL DESCRIPTIONS

<i>Paragraph</i>	<i>Page</i>	<i>Paragraph</i>	<i>Page</i>
1. General.....	1-1	<i>d.</i> Chassis Base MX-24/APR-1.....	1-3
2. Frequency Range.....	1-1	<i>e.</i> Airborne Antennae.....	1-5
3. Equipment Supplied.....	1-1	<i>f.</i> Shipborne Antennae.....	1-5
<i>a.</i> Radio Receiving Equipment AN/APR-1 (Airborne).....	1-1	<i>g.</i> R. F. Switch SA-14/SPR-1.....	1-7
<i>b.</i> Radio Receiving Equipment AN/SPR-1 (Shipborne).....	1-2	<i>h.</i> R. F. Switch SA-44 (A)/APR.....	1-7
4. Equipment Required But Not Supplied.....	1-2	<i>i.</i> Case CY-57/APR-1.....	1-8
5. Weight Assembled.....	1-3	<i>j.</i> Sector Sweep Tuners.....	1-8
6. Power Source.....	1-3	<i>k.</i> Filter F-41/SPR-1.....	1-8
7. Power Requirements.....	1-3	<i>l.</i> Rectifier Filter Unit PP-183/SPR-1.....	1-8
8. Tube Components of Radio Receiving Equipment AN/APR-1 and AN/SPR-1	1-3	<i>m.</i> Wave Trap F-19/UPR.....	1-8
9. Description of Major Units.....	1-3	<i>n.</i> Wave Trap F-20/UPR.....	1-9
<i>a.</i> Amplifier Strip AM-12/APR-1.....	1-3	<i>o.</i> Junction Box J-116/SPR.....	1-9
<i>b.</i> Cover *CW-52/UR.....	1-3	10. Associated Equipment.....	1-9
<i>c.</i> Mounting Base MT-141/APR-1 or MT- 160/SPR-1.....	1-3	<i>a.</i> Panoramic Adapter R D P.....	1-9
		<i>b.</i> Pulse Analyzer Equipment R D J.....	1-9
		<i>c.</i> Use of the Radio Receiving Equipment AN/APR-1 and AN/SPR-1 with Other Similar Equipment.....	1-10

### SECTION II. INSTALLATION AND ADJUSTMENT

1. General.....	2-1	<i>i.</i> Rectifier Filter PP-183/SPR-1.....	2-3
2. Receiver Installation, General.....	2-1	4. Airborne Installation.....	2-3
3. Shipborne Installation.....	2-1	<i>a.</i> Mounting Base MT-141-A/APR-1.....	2-3
<i>a.</i> Mounting Base MT-160/SPR-1.....	2-1	<i>b.</i> Carrying Case CY-57/APR-1.....	2-3
<i>b.</i> Carrying Case CY-57/APR-1.....	2-1	<i>c.</i> Receiver Installation.....	2-3
<i>c.</i> Receiver Installation.....	2-1	<i>d.</i> Cable Installation.....	2-3
<i>d.</i> Cable Installation.....	2-2	<i>e.</i> Antennae Installation.....	2-4
<i>e.</i> Antennae Installation.....	2-2	5. Test Equipment.....	2-4
<i>f.</i> Switch SA-44(A)/APR.....	2-2	6. Pre-Installation Tests and Adjustments....	2-4
<i>g.</i> Wave Traps F-19/UPR and F-20/UPR.	2-3	7. Operational Check.....	2-5
<i>b.</i> Junction Box J-116/SPR.....	2-3	8. Test Check List.....	2-6

### SECTION III. OPERATION

1. Description of Controls.....	3-1	4. Use of Wave Traps to Determine Exact Sig- nal Frequency of Incoming Signal.....	3-3
<i>a.</i> Receiver.....	3-1	<i>a.</i> Wave Trap F-19/UPR.....	3-3
<i>b.</i> Tuning Unit.....	3-1	<i>b.</i> Wave Trap F-20/UPR.....	3-5
2. Operation.....	3-1	5. Junction Box J-116/UPR.....	3-5
3. Signal Characteristics.....	3-3	6. R.F. Switch SA-14/SPR-1.....	3-5

### SECTION IV. THEORY OF OPERATION

1. Tuning Unit TN-1/APR-1, Electrical Function.....	4-1	6. Tuning Unit TN-1/APR-1, Mechanical Function.....	4-4
2. Tuning Unit TN-2/APR-1 and Tuning Unit TN-3/APR-1, Electrical Functions....	4-1	7. Tuning Units TN-2/APR-1, and TN-3/ APR-1 Mechanical Functions.....	4-4
3. Tuning Unit TN-4A/APR-1, Electrical Function.....	4-2	8. Tuning Unit TN-4A/APR-1, Mechanical Functions.....	4-5
4. Amplifier Strip AM-12/APR-1, Electrical Function.....	4-3	9. Sector Sweep, Electrical and Mechanical Functions.....	4-5
5. Rectifier Unit PP-10/APR-1, Electrical Function.....	4-3		

## LIST OF CONTENTS (Cont.)

### SECTION V. MAINTENANCE

<i>Paragraph</i>	<i>Page</i>	<i>Paragraph</i>	<i>Page</i>
1. General.....	5-1	7. Alignment of Tuning Unit TN-4A/APR-1.	5-3
2. Removal of Amplifier Strip AM-12/APR-1.	5-1	8. Trouble Shooting.....	5-4
3. Removal of Rectifier PP-10/APR-1.....	5-1	<i>a.</i> Basic Chassis.....	5-4
4. Alignment Procedure for Amplifier Strip AM-12/APR-1.....	5-1	<i>b.</i> Tuning Unit TN-1/APR.....	5-5
5. Alignment of Tuning Units TN-1/APR-1 and Tuning Unit TN-1B/APR-1.....	5-2	<i>c.</i> Tuning Units TN-2/APR-1 and TN-3/APR-1.....	5-5
<i>a.</i> Tracking.....	5-2	9. Hash Elimination from TN-(*)B/APR-1 Sector Sweep Tuners.....	5-6
6. Alignment of Tuning Units TN-2/APR-1 and TN-3/APR-1.....	5-2	10. Wave Trap F-19/UPR.....	5-7
<i>a.</i> Cam Adjustment.....	5-2	11. Wave Trap F-20/UPR.....	5-8
<i>b.</i> Calibration.....	5-3	12. Lubrication.....	5-8
<i>c.</i> Filter.....	5-3	13. Trouble Chart.....	5-9

### SECTION VI. SUPPLEMENTARY DATA

1. General.....	6-1	3. Summary of Tuners.....	6-2
2. Summary of Basic Chassis.....	6-1	4. Color Codes.....	6-58

### SECTION VII. TABLE OF REPLACEABLE PARTS

1. Amplifier Strip AM-12/APR-1.....	7-2	6. Tuning Unit TN-1/APR-1.....	7-46
2. Rectifier PP-10/APR-1.....	7-9	7. Tuning Unit TN-3B/APR-1.....	7-54
3. Chassis Base MX-24/APR-1.....	7-13	8. Tuning Unit TN-28/APR-1.....	7-71
4. Tuning Unit TN-3/APR-1.....	7-21	9. Tuning Unit TN-1B/APR-1.....	7-82
5. Tuning Unit TN-2/APR-1.....	7-36	10. Manufacturers Names and Addresses.....	7-93

### SECTION VIII. DRAWINGS

### SECTION IX. INDEX

## LIST OF ILLUSTRATIONS

<i>Figure</i>	<i>List of Illustrations</i>	<i>Page</i>
1-1	Radio Receiving Equipment AN/APR-1 and AN/SPR-1, with Tuning Units.....	1-0
1-2	Radio Receiving Equipment AN/APR-1, Block Diagram.....	1-4
1-3	Stub Antenna AT-37/APT.....	1-5
1-4	Stub Antenna AT-37A/APT.....	1-5
1-5	Cone Antenna AS-26/APR-2.....	1-5
1-6	Radio Receiving Equipment AN/SPR-1, Block Diagram.....	1-6
1-7	Antenna CAGW-66131.....	1-7
1-8	Antenna CAGW-66132.....	1-7
1-9	Case CY-57/APR-1.....	1-8
1-10	Case CY-57/APR-1 with Tuning Unit.....	1-8
1-11	Sector Sweep Tuner, Front Panel.....	1-8
1-12	Filter F-41/SPR-1.....	1-9
1-13	Rectifier Filter PP-183/SPR-1 with Receiver.....	1-9
1-14	Wave Trap F-19/UPR.....	1-9
1-15	Wave Trap F-20/UPR.....	1-10
3-1	Amplifier Strip AM-12/APR-1 and Rectifier PP-10/APR-1, Front View.....	3-2
3-2	Sector Sweep Tuner, Front Panel Open.....	3-4
3-3	Wave Trap F-20/UPR, Operation.....	3-6
6-1	Tuning Unit TN-1/APR-1, Top View.....	6-3
6-2	Tuning Unit TN-1B/APR-1, Left Side View.....	6-3
6-3	Tuning Unit TN-1/APR-1, Left Front Oblique View.....	6-4
6-4	Tuning Unit TN-1/APR-1, Rear View.....	6-4
6-5	Tuning Unit TN-1/APR-1, Right Side View.....	6-5
6-6	Tuning Unit TN-2/APR-1, Left Side View.....	6-5
6-7	Tuning Unit TN-2/APR-1, Front View.....	6-6
6-8	Tuning Unit TN-2/APR-1, Right Front Oblique View.....	6-6
6-9	Tuning Unit TN-2/APR-1, Right Side View.....	6-7
6-10	Tuning Unit TN-2/APR-1, Rear View.....	6-7
6-11	Tuning Unit TN-2/APR-1, Right Rear Oblique View.....	6-8
6-12	Tuning Unit TN-2/APR-1, Rear Left Oblique View.....	6-8
6-13	Tuning Unit TN-2/APR-1, Left Front Oblique View.....	6-9
6-14	Tuning Unit TN-3/APR-1, Front View.....	6-9
6-15	Tuning Unit TN-3/APR-1, Right Front Oblique View.....	6-10
6-16	Tuning Unit TN-3/APR-1, Right Side View.....	6-10
6-17	Tuning Unit, TN-3/APR-1, Rear Right Oblique View.....	6-11
6-18	Tuning Unit TN-3/APR-1, Rear View.....	6-11
6-19	Tuning Unit TN-3/APR-1, Rear Left Oblique View.....	6-12
6-20	Tuning Unit TN-3/APR-1, Left Side View.....	6-12
6-21	Tuning Unit TN-3/APR-1, Front Left Oblique View.....	6-13
6-22	Sector Sweep Tuner, Bottom Right Oblique.....	6-13
6-23	Sector Sweep Tuner, Parts Location, Top Right Oblique.....	6-14
6-24	Sector Sweep Tuner, Bottom Left Oblique.....	6-14
6-25	Rectifier Filter Unit PP-183/SPR-1, Right Oblique, with Cover.....	6-15
6-26	Rectifier Filter PP-183/SPR-1, Left Oblique.....	6-15
6-27	Jack Box J-116/SPR Diagram.....	6-16
6-28	Antenna AS-124/APR Outline.....	6-17
6-29	Wave Trap F-19/UPR, Open View.....	6-17
6-30	Dipole Antenna AS-56/SPR-1.....	6-18
6-31	Double Cone Antenna AS-57/SPR-1, Side View.....	6-18
6-32	Double Cone Antenna AS-57/SPR-1, Oblique View.....	6-19
6-33	Double Cone Antenna AS-57/SPR-1, End View.....	6-19
6-34	Impedance Matching Transformer CU-19/SPR-1.....	6-20
6-35	Impedance Matching Transformer CU-27/SPR-1.....	6-20
6-36	Impedance Matching Transformer CU-19/SPR-1 or CU-27/SPR-1, Upper End View.....	6-21
6-37	Impedance Matching Transformer CU-19/SPR-1 or CU-27/SPR-1, Lower End View.....	6-21
6-38	Radio Frequency Switch SA-14/SPR-1.....	6-22
6-39	Cone Antenna AS-44/APR-5.....	6-22
6-40	Wave Trap F-41/SPR-1, Open View.....	6-23
6-41	Tuning Unit TN-4A/APR-1.....	6-23
6-42	Sector Sweep Cover.....	6-24

## LIST OF ILLUSTRATIONS (Cont.)

<i>Figure</i>	<i>List of Illustrations</i>	<i>Page</i>
6-43	Sector Sweep Motor.....	6-24
6-44	Sector Sweep, Top Panel.....	6-24
6-45	Amplifier Strip AM-12/APR-1 and Rectifier PP-10/APR-1, Bottom View.....	6-25
6-46	Amplifier Strip AM-12/APR-1, Rectifier PP-10/APR-1 and Tuning Unit, Left Front Oblique View..	6-26
6-47	Amplifier Strip AM-12/APR-1 and Rectifier PP-10/APR-1, Rear Right Oblique View.....	6-27
6-48	Amplifier Strip AM-12/APR-1 and Rectifier PP-10/APR-1, Rear View.....	6-28
6-49	Amplifier Strip AM-12/APR-1 and Rectifier PP-10/APR-1, Rear Left Oblique View.....	6-29
6-50	Amplifier Strip AM-12/APR-1, Rectifier PP-10/APR-1 and Tuning Unit, Right Front Oblique View	6-30
6-51	Amplifier Strip AM-12/APR-1, Rectifier PP-10/APR-1 and Tuning Unit, Top View .....	6-31
6-52	Radio Receiving Equipment AN/APR-1 and AN/SPR-1, Overall Dimensional.....	6-32
6-53	Mounting MT-141/APR-1 and MT-160/SPR-1, Outline Dimensional and Hole Location Detail....	6-33
6-54	Carrying Case CY-57/APR-1 with Tuning Unit, Outline Dimensional.....	6-34
6-55	Antenna AT-37/APT, Outline Dimensional.....	6-35
6-56	Ring Cone Mounting.....	6-36
6-57	Double Cone Antenna AS-57/APR-1, Outline Dimensional.....	6-37
6-58	Dipole Antenna AS-56/SPR-1, Outline Dimensional.....	6-38
6-59	Nacelle CW-3/AP, Outline Dimensional.....	6-39
6-60	Impedance Matching Transformer CU-27/SPR-1, Outline Dimensional.....	6-40
6-61	Impedance Matching Transformer CU-19/SPR-1, Outline Dimensional.....	6-41
6-62	Frequency Switch SA-14/SPR-1, Outline Dimensional.....	6-42
6-63	Wave Trap F-19/UPR, Outline Dimensional and Schematic.....	6-43
6-64	Tuning Unit TN-1B/APR-1, Sensitivity Chart.....	6-44
6-65	Tuning Unit TN-2B/APR-1, Sensitivity Chart.....	6-45
6-66	Tuning Unit TN-3B/APR-1, Sensitivity Chart.....	6-46
6-67	Amplifier Strip AM-12/APR-1, Resistor and Choke Location.....	6-47
6-68	Amplifier Strip AM-12/APR-1, Capacitor Location.....	6-48
6-69	Connector Assembly.....	6-49
6-70	Connector Assembly.....	6-50
6-71	Connector Assembly.....	6-51
6-72	Amplifier Strip AM-12/APR-1 and Rectifier PP-10/APR-1, Tube Socket Voltage Diagram.....	6-52
6-73	Amplifier Strip AM-12/APR-1, Chassis Tube Socket Resistance Diagram, Bottom View.....	6-53
6-74	Amplifier Strip AM-12/APR-1 and Rectifier PP-10/APR-1, Terminal Board Voltage Diagram.....	6-54
6-75	Amplifier Strip AM-12/APR-1 and PP-10/APR-1, Terminal Board Resistance Diagram.....	6-55
6-76	Tuning Units, Tube Socket and Resistance Diagram.....	6-56
6-77	R.F. Switch SA-44 (A)/APR, Top View .....	6-57
6-78	R. F. Switch SA-44 (A)/APR, Bottom View.....	6-57
8-1	Rectifier Filter PP-183/SPR-1, Schematic.....	8-1
8-2	Tuning Unit TN-1/APR-1, Schematic Diagram.....	8-2
8-3	Tuning Unit TN-1B/APR-1, Schematic Diagram.....	8-3
8-4	Tuning Unit TN-1B/APR-1, Practical Wiring Diagram.....	8-4
8-5	Tuning Unit TN-2/APR-1, Schematic Diagram.....	8-5
8-6	Tuning Unit TN-2B/APR-1, Schematic Diagram.....	8-6
8-7	Tuning Unit TN-2B/APR-1, Practical Wiring Diagram.....	8-7
8-8	Tuning Unit TN-3/APR-1, Schematic Diagram.....	8-8
8-9	Tuning Unit TN-3B/APR-1, Practical Wiring Diagram.....	8-10
8-10	Tuning Unit TN-3B/APR-1, Schematic Diagram.....	8-11
8-11	Tuning Unit TN-4A/APR-1, Schematic.....	8-12
8-12	Radio Receiving Equipment AN/APR-1 and AN/SPR-1, Practical Wiring Diagram.....	8-13
8-13	Radio Receiving Equipment AN/APR-1 and AN/SPR-1, Schematic Diagram.....	8-15

### **FOR U. S. ARMY AIR FORCE PERSONNEL**

In the event of malfunctioning, unsatisfactory design or unsatisfactory installation of any of the component units of this equipment, or if the material contained in this book is considered inadequate or erroneous, an Unsatisfactory Report, AAF Form No. 54 or a report in similar form shall be submitted in accordance with the provisions of Army Air Force Regulation No. 15-54, listing:

1. Station and organization.
2. Nameplate data (type number or complete nomenclature if nameplate is not attached to the equipment).
3. Date and nature of failure.
4. Airplane model and serial number.
5. Remedy used or proposed to prevent recurrence.
6. Handbook errors or inadequacies, if applicable.

### **FOR U. S. NAVY AIR PERSONNEL**

Report of failure of any part of this equipment during its guaranteed life shall be made on Nav SandA Form 309 "Stub Requisition and Report of Unsatisfactory, Defective or Damaged Class 16 Material", or a report in similar form, and forwarded in accordance with the latest instructions of the Bureau of Aeronautics. Such reports of failure shall include:

1. Reporting Activity
2. Nameplate data
3. Date placed in service
4. Part which failed
5. Nature and cause of failure
6. Remedy used or proposed to prevent recurrence

### **FOR NAVY SHIPSHORE PERSONNEL**

"Report of failure of any part of this equipment, during its service life, shall be made to the Bureau of Ships in accordance with current instructions. The report shall cover all details of the failure and give the date of installation of the equipment. For procedure in reporting failures see Chapter 57 of the 'Bureau of Ships Manual', or superseding instructions."

### **FOR BRITISH PERSONNEL**

Form 1022 procedure shall be used when reporting failure of radio equipment.

## DESTRUCTION OF ABANDONED MATERIEL IN THE COMBAT ZONE

In case it should become necessary to prevent the capture of this equipment and when ordered to do so,

DESTROY IT SO THAT NO PART OF IT CAN  
BE SALVAGED, RECOGNIZED OR USED BY  
THE ENEMY. BURN ALL PAPERS AND BOOKS.

*Means:*

1. Explosives, when provided.
2. Hammers, axes, sledges or whatever heavy object is readily available.
3. Burning by means of incendiaries such as gasoline, oil, paper or wood.
4. Grenades and shots from available arms.
5. Where possible, and when time permits, bury all debris or dispose of it in streams or other bodies of water.

*Procedure:*

1. Obliterate all identifying marks. Destroy nameplates and circuit labels.
2. Demolish all panels, castings, switch and instrument boards.
3. Destroy all controls, switches, relays, connections and meters.
4. Rip out all wiring in electrical equipment. Smash gas, oil, and water cooling systems in gas-engine generators, etc.
5. Smash every electrical or mechanical part whether rotating, moving or fixed.
6. Break up all operating instruments such as keys, phones, microphones, etc.
7. Destroy all classes of carrying cases, straps, containers, etc.

## SAFETY NOTICE

OPERATION OF THIS EQUIPMENT INVOLVES THE USE OF HIGH VOLTAGES WHICH ARE DANGEROUS TO LIFE. OPERATING PERSONNEL MUST AT ALL TIMES OBSERVE ALL SAFETY PRECAUTIONS. DO NOT CHANGE TUBES OR MAKE ADJUSTMENTS INSIDE EQUIPMENT WITH HIGH VOLTAGE SUPPLY ON. DO NOT DEPEND UPON DOOR SWITCHES OR INTERLOCKS FOR PROTECTION BUT ALWAYS SHUT DOWN MOTOR GENERATORS OR OTHER POWER EQUIPMENT. UNDER CERTAIN CONDITIONS DANGEROUS POTENTIALS MAY EXIST IN CIRCUITS WITH POWER CONTROL IN THE "OFF" POSITION DUE TO CHARGES RETAINED BY CAPACITORS, ETC. TO AVOID CASUALTIES ALWAYS DISCHARGE AND GROUND CIRCUITS PRIOR TO TOUCHING THEM.

THE ATTENTION OF OFFICERS AND OPERATING PERSONNEL IS DIRECTED TO BUREAU OF SHIPS MANUAL OF ENGINEERING INSTRUCTIONS, CHAPTER 31 (MIMEOGRAPHED FORM) OR SUBSEQUENT REVISIONS THEREOF, ON THE SUBJECT OF RADIO-SAFETY PRECAUTIONS TO BE OBSERVED.



## GUARANTEE

This equipment, including all parts and spare parts, except vacuum tubes, is guaranteed for a period of ONE YEAR with the understanding that, as a condition of this contract, all items found to be defective as to design, material, workmanship or manufacture will be replaced without delay and at no expense to the Government; provided that such guarantee and agreement will not obligate the contractor to make replacement of defective material unless the failure exclusive of normal expected shelf life deterioration, occurs within a period of ONE YEAR from the date of delivery of the equipment to an acceptance by the Government, and provided further, that if any part or parts fail or are found defective to the extent of ten per cent (10%) or more of the total number of similar units furnished under the contract (exclusive of spares), such part or parts, whether supplied in the equipment or as spares, will be conclusively presumed to be of defective design, and as a condition of contract subject to one hundred per cent (100%) replacement by suitable redesigned units.

Failure due to poor workmanship, while not necessarily indicating poor design, will be considered in the same category as failure due to poor design. Redesigned replacements which will assure proper operation of the equipment shall be supplied promptly, transportation paid, to the Naval activity using such equipment, upon receipt of proper notice and without cost to the Government.

All such defective parts will be subject to ultimate return to the contractor. In view of the fact that normal activities of the Naval service may result in the use of equipment in such remote portions of the world or under such conditions as to preclude the return of the defective item or unit prior to replacement without jeopardizing the integrity of Naval operations or communications, the exigencies of the service therefore may necessitate expeditious repair of such item or unit in order to prevent extended interruption of operations or communications. In such cases the return of the defective item or unit for examination by the contractor prior to replacement will not be required. The report of a responsible authority, including details of the conditions surrounding the failure, will be acceptable for effective adjustment under the provisions of this contractual guarantee.

The above period of ONE YEAR will not include any portion of the time that the equipment fails to give satisfactory performance due to defective items and the necessity for replacement thereof. All replacement parts will be guaranteed to give ONE YEAR of satisfactory service.

**RESTRICTED**  
**AN-16-30APR-1-3**  
**NAVSHIPS 900, 483A**



RESTRICTED  
AN-16-30APR-1-3  
NAVSHIPS 900, 483A

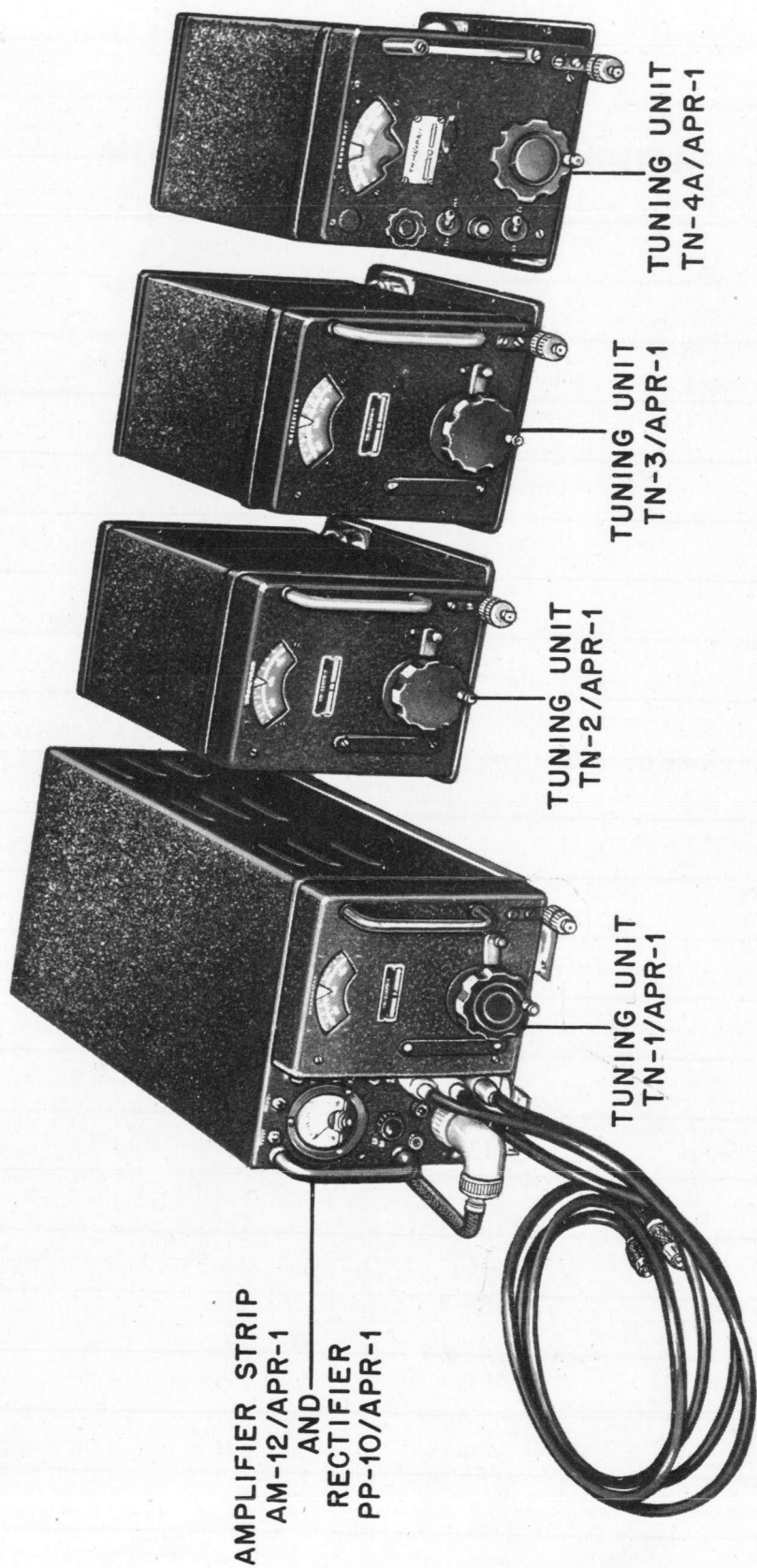

Figure 1-1. Radio Receiving Equipment AN/APR-1 and AN/SPR-1 with Tuning Units.

## SECTION I — GENERAL DESCRIPTION

### 1. GENERAL.

Radio Receiving Equipment AN/APR-1 or AN/SPR-1 is a search receiver designed to measure the frequency of radar or radio signals within its frequency range. It is a superheterodyne type of receiver, complete in itself, but may be used with associated equipment. (Figs. 1-1, 1-2 and 1-6.)

**NOTE:**

*Radio Receiving Equipment AN/APR-1 (Airborne) and AN/SPR-1 (Shipborne) are identical except for antennae, varying in operation and installation depending upon whether the unit is installed on an aircraft or ship.*

### 2. FREQUENCY RANGE.

The frequency range of the equipment is from 38 to 3200 megacycles. This range is covered in four bands by means of four separate tuners as follows:

- ✓ Tuning Unit TN-1/APR-1  
38-95 MC
- ✓ Tuning Unit TN-2/APR-1  
76-300 MC
- ✓ Tuning Unit TN-3/APR-1  
300-1000 MC
- Tuning Unit TN-4A/APR-1  
1000-3200 MC

**NOTE:**

*Throughout the text, description of the electrical and mechanical characteristics apply to the above tuners.*

### 3. EQUIPMENT SUPPLIED.

a. RADIO RECEIVING EQUIPMENT AN/APR-1 (Airborne).

Quantity per Equipment	Name of Unit	Navy Type Designation	Overall Dimensions (In Inches)	Weight	Numerical Series of Reference Symbols
1	Amplifier Strip	AM-12/APR-1	4 <sup>7</sup> / <sub>8</sub> x 9 <sup>7</sup> / <sub>8</sub> x 11 <sup>5</sup> / <sub>16</sub>	3 lbs. 12 oz.	100-199
1	Rectifier	PP-10/APR-1	5 <sup>3</sup> / <sub>16</sub> x 7 <sup>1</sup> / <sub>4</sub> x 9 <sup>13</sup> / <sub>16</sub>	18 lbs. 3 oz.	200-299
1	Chassis Base	MX-24/APR-1	7 <sup>7</sup> / <sub>8</sub> x 10 <sup>1</sup> / <sub>4</sub> x 21 <sup>1</sup> / <sub>8</sub>	3 lbs. 3 oz.	300-399
1	Tuning Unit	TN-1/APR-1	6 <sup>1</sup> / <sub>2</sub> x 7 <sup>3</sup> / <sub>4</sub> x 13 <sup>7</sup> / <sub>16</sub>	8 lbs. 8 oz.	600-699
		or:			
1	Tuning Unit	TN-1B/APR-1 TN-2/APR-1	6 <sup>1</sup> / <sub>2</sub> x 7 <sup>3</sup> / <sub>4</sub> x 15 <sup>1</sup> / <sub>2</sub> 6 <sup>1</sup> / <sub>2</sub> x 7 <sup>3</sup> / <sub>4</sub> x 13 <sup>7</sup> / <sub>16</sub>	10 lbs. 11 lbs. 8 oz.	1000-1099 500-599
		or:			
1	Tuning Unit	TN-2B/APR-1 TN-3/APR-1	6 <sup>1</sup> / <sub>2</sub> x 7 <sup>3</sup> / <sub>4</sub> x 15 <sup>1</sup> / <sub>2</sub> 6 <sup>1</sup> / <sub>2</sub> x 7 <sup>3</sup> / <sub>4</sub> x 13 <sup>7</sup> / <sub>16</sub>	13 lbs. 12 lbs.	900-999 400-499
		or:			
1	Cover (Alum.)	TN-3B/APR-1	6 <sup>1</sup> / <sub>2</sub> x 7 <sup>3</sup> / <sub>4</sub> x 15 <sup>1</sup> / <sub>2</sub>	13 lbs. 8 oz.	700-899
1	Mounting Base	*CW-52/UR	7 <sup>3</sup> / <sub>4</sub> x 10 <sup>1</sup> / <sub>2</sub> x 19 <sup>3</sup> / <sub>8</sub>	3 lbs. 14 oz.	
1	Carrying Case	MT-141/APR-1	2 <sup>1</sup> / <sub>2</sub> x 10 <sup>7</sup> / <sub>16</sub> x 24 <sup>7</sup> / <sub>8</sub>	2 lbs. 3 oz.	
3	Filter	CY-57/APR-1	6 <sup>1</sup> / <sub>2</sub> x 8 <sup>7</sup> / <sub>8</sub> x 11	7 lbs.	
1	Filter	F-41/APR-1	1 <sup>3</sup> / <sub>16</sub> x 5 <sup>3</sup> / <sub>4</sub> x 5 <sup>11</sup> / <sub>16</sub>	10 oz.	

b. RADIO RECEIVING EQUIPMENT AN/SPR-1 (Shipborne).

Quantity per Equipment	Name of Unit	Navy Type Designation	Overall Dimensions (In Inches)	Weight	Numerical Series of Reference Symbols
1	Amplifier Strip	AM-12/APR-1	4 <sup>7</sup> / <sub>8</sub> x 9 <sup>7</sup> / <sub>8</sub> x 11 <sup>5</sup> / <sub>16</sub>	3 lbs. 12 oz.	100-199
1	Rectifier	PP-10/APR-1	5 <sup>3</sup> / <sub>16</sub> x 7 <sup>1</sup> / <sub>4</sub> x 9 <sup>13</sup> / <sub>16</sub>	18 lbs. 3 oz.	200-299
1	Chassis Base	MX-24/APR-1	7 <sup>7</sup> / <sub>8</sub> x 10 <sup>1</sup> / <sub>4</sub> x 2 <sup>1</sup> / <sub>4</sub>	3 lbs. 3 oz.	300-399
1	Tuning Unit	TN-1/APR-1	6 <sup>1</sup> / <sub>2</sub> x 7 <sup>3</sup> / <sub>4</sub> x 13 <sup>7</sup> / <sub>16</sub>	8 lbs. 8 oz.	600-699
			or:		
1	Tuning Unit	TN-1B/APR-1 TN-2/APR-1	6 <sup>1</sup> / <sub>2</sub> x 7 <sup>3</sup> / <sub>4</sub> x 15 <sup>1</sup> / <sub>2</sub> 6 <sup>1</sup> / <sub>2</sub> x 7 <sup>3</sup> / <sub>4</sub> x 13 <sup>1</sup> / <sub>2</sub>	10 lbs. 11 lbs. 11 oz.	1000-1099 500-599
			or:		
1	Tuning Unit	TN-2B/APR-1 TN-3/APR-1	6 <sup>1</sup> / <sub>2</sub> x 7 <sup>3</sup> / <sub>4</sub> x 15 <sup>1</sup> / <sub>2</sub> 6 <sup>1</sup> / <sub>2</sub> x 7 <sup>3</sup> / <sub>4</sub> x 13 <sup>7</sup> / <sub>16</sub>	13 lbs. 12 lbs.	900-999 400-499
			or:		
1	Cover (Steel)	TN-3B/APR-1	6 <sup>1</sup> / <sub>2</sub> x 7 <sup>3</sup> / <sub>4</sub> x 15 <sup>1</sup> / <sub>2</sub>	13 lbs. 8 oz.	700-899
1	Mounting Base	*CW-52/UR	7 <sup>3</sup> / <sub>4</sub> x 10 <sup>1</sup> / <sub>2</sub> x 19 <sup>5</sup> / <sub>8</sub>	14 lbs. 4 oz.	
3	Carrying Case	MT-160/SPR-1	2 <sup>1</sup> / <sub>2</sub> x 10 <sup>7</sup> / <sub>16</sub> x 24 <sup>7</sup> / <sub>8</sub>	2 lbs. 3 oz.	
1	Dipole Antenna	CY-57/APR-1	6 <sup>1</sup> / <sub>2</sub> x 8 <sup>7</sup> / <sub>8</sub> x 11	7 lbs.	
		AS-56/SPR-1 (Obsolete)	7 x 31 <sup>1</sup> / <sub>4</sub> x 66	17 lbs.	
1	Double Cone Antenna	AS-57/SPR-1 (Obsolete)	9 x 17 x 21	18 lbs. 14 oz.	
1	Cone Antenna	AS-44/APR-5 (Obsolete)	6 x 7 x 3 <sup>4</sup> / <sub>4</sub>	2 lbs. 4 oz.	
1	R. F. Switch	SA-14/SPR-1	8 x 8 <sup>1</sup> / <sub>4</sub>	8 lbs. 6 oz.	
1	Impedance Matching Transformer (Obsolete)	CU-19/SPR-1	3 x 4 x 49 <sup>1</sup> / <sub>2</sub>	22 lbs.	
1	Impedance Matching Transformer (Obsolete)	CU-27/SPR-1	3 x 4 x 16 <sup>3</sup> / <sub>8</sub>	7 lbs. 14 oz.	
1	Filter	F-41/SPR-1	1 <sup>3</sup> / <sub>16</sub> x 5 <sup>3</sup> / <sub>4</sub> x 5 <sup>11</sup> / <sub>16</sub>	10 oz.	
1	*Rectifier Filter	PP-183/SPR-1	5 x 7 <sup>1</sup> / <sub>2</sub> x 10 <sup>1</sup> / <sub>4</sub>	7 lbs.	

\*NOTE: Not supplied with all equipments.

4. EQUIPMENT REQUIRED BUT NOT SUPPLIED.

a. AIRBORNE.

1	Stub Antenna	AT-37/APT or: AT-37A/APT	6 x 8 <sup>1</sup> / <sub>2</sub> x 30 <sup>3</sup> / <sub>4</sub>	6 lbs. 2 oz.	
1	Cone Antenna	AS-26/APR-2	4 <sup>1</sup> / <sub>2</sub> x 5 <sup>1</sup> / <sub>32</sub> x 30 <sup>3</sup> / <sub>4</sub>	5 lbs. 4 oz.	
1	Stub Antenna	AT-36/APT or: AT-36A/APT	6 <sup>1</sup> / <sub>8</sub> x 10 6 x 8 <sup>1</sup> / <sub>2</sub> x 24 <sup>3</sup> / <sub>4</sub>	2 lbs. 4 oz. 5 lbs. 6 oz.	
			or:		
1	Stub Antenna	AT-38/APT	4 <sup>1</sup> / <sub>2</sub> x 5 <sup>1</sup> / <sub>32</sub> x 24 <sup>3</sup> / <sub>4</sub>	5 lbs.	
		AT-38A/APT	6 x 8 <sup>1</sup> / <sub>2</sub> x 37 <sup>1</sup> / <sub>4</sub>	6 lbs. 6 oz.	
1	Cone Antenna	AS-124/APR	4 <sup>1</sup> / <sub>2</sub> x 5 <sup>1</sup> / <sub>32</sub> x 37 <sup>1</sup> / <sub>4</sub>	5 lbs. 8 oz.	
1	Nacelle	CW-3/AP	3 <sup>7</sup> / <sub>8</sub> x 6 <sup>1</sup> / <sub>4</sub>	1 lb. 2 oz.	
			8 x 9 <sup>1</sup> / <sub>2</sub> x 22 <sup>1</sup> / <sub>2</sub>	1 lb. 2 oz.	

b. SHIPBORNE.

1	Cone Antenna	CAGW66131	11 <sup>1</sup> / <sub>2</sub> x 13	13 lbs.	
1	Stub Antenna	CAGW66132	38 x 39 <sup>11</sup> / <sub>16</sub> x 67 <sup>5</sup> / <sub>8</sub>	27 lbs. 8 oz.	
1	Cone Antenna	AS-44/APR-5 or: AS-125/APR	6 x 7 <sup>1</sup> / <sub>2</sub>	2 lbs. 4 oz.	
		J-116/SPR-1	16 x 6 x 2	8 lbs.	
1	R. F. Jack Box	F-19/UPR	4 <sup>5</sup> / <sub>16</sub> x 4 <sup>1</sup> / <sub>2</sub> x 4 <sup>21</sup> / <sub>32</sub>	2 lbs. 8 oz.	
1	Wave Trap	F-20/UPR	3 <sup>3</sup> / <sub>16</sub> x 20 <sup>3</sup> / <sub>4</sub>	3 lbs. 3 oz.	
1	Wave Trap				

**5. WEIGHT ASSEMBLED.**

Radio Receiving Equipment AN/APR-1 (Airborne) weighs approximately 86 pounds, less antennae, as listed in Section I Paragraph 3 a, with manual tuning units.

Radio Receiving Equipment AN/SPR-1 (Shipborne) weighs approximately 100 pounds, less antennae, as listed in Section I Paragraph 3 b, with manual tuning units.

If SECTOR SWEEP tuners are used with the above equipment, add approximately 2 pounds to the weight of the equipment for each SECTOR SWEEP tuner replacing a manual tuner.

**6. POWER SOURCE.**

Radio Receiving Equipment AN/APR-1 and AN/SPR-1 will operate from a single-phase, 80 or 115 volts, AC., 60 to 2600 cycle power source. The receiver is normally set up for 115 volt operation but in the event that an 80 volt source is to be used, a tap is provided on the power transformer. The receiver is also normally designed to operate with a 600 ohm load, although, if necessary, a tap is provided for operation with an 8000 ohm load. This tap is located on the output transformer of the Amplifier Strip AM-12/APR-1. The current drain of the receiver is 1.2 amperes at 117 volts.

**7. POWER REQUIREMENTS.**

Rectifier PP-10/APR-1 is divided into two high voltage secondaries, one secondary delivery approximately 115 volts at 100 milliamperes to the I. F. amplifiers, video audio stage and the heterotone oscillator; and the other secondary supplying 250 volts at 55 milliamperes to the oscillators of the tuner units. The power input is 110 watts.

**8. TUBE COMPONENTS OF RADIO RECEIVING EQUIPMENT AN/APR-1 and AN/SPR-1.**

Major Units	Tube	Function
Tuning Unit		
TN-1/APR-1	2-Type 9002	Oscillator, Mixer
TN-2/APR-1	2-Type 955 Triode	Oscillator, Mixer
TN-3/APR-1	1-Type 955 Triode	Oscillator
TN-4A/APR-1	1-Type W.E. 703-A 1-6E5	Oscillator Oscillator indicator

Amplifier Strip

AM-12/APR-1	6-Type 6AC7	I.F. Amplifiers and Heterotone Oscillator
	1-Type 6H6 Twin Diode	Detector and AVC
	1-Type 6AG7 Pentode	Audio and cathode-follower
Rectifier		
PP-10/APR-1	2-Type 5Y3GT	Rectifiers

**9. DESCRIPTION OF MAJOR UNITS.**

*a. AMPLIFIER STRIP AM-12/APR-1.*

The Amplifier Strip AM-12/APR-1 is composed of an intermediate frequency amplifier, detector, automatic and/or manual gain control, heterotone oscillator, and an audio and video circuit (cathode-follower).

(1) A heterotone oscillator circuit is incorporated in the intermediate frequency amplifier strip in order to render CW signals audible.

(2) An audio and cathode follower circuit permits the simultaneous use of headphones and Pulse Analyzer Equipment, and a connection is provided for connecting a panoramic adapter.

*b. COVER \*CW-52/UR.*

Cover \*CW-52/UR serves as a dust cover for Radio Receiving Equipment AN/APR-1 and AN/SPR-1. It is made of steel (Shipborne) or aluminum (Airborne), dull black fine wrinkle finish. (Fig. 1-1.)

*c. MOUNTING BASE MT-141/APR-1 OR MT-160/SPR-1.*

The mounting base is an aluminum alloy, or steel rack, for mounting the Radio Receiving Equipment AN/APR-1 and AN/SPR-1. (Fig. 1-1.)

*d. CHASSIS BASE MX-24/APR-1.*

Chassis Base MX-24/APR-1 mounts the Amplifier Strip AM-12/APR-1, Rectifier Unit PP-10/APR-1, and tuning units. These units are separable for servicing replacement, if desired, and to make it possible to change the I. F. or power supply characteristics to meet future design requirements. Under all ordinary conditions these units should never be removed.

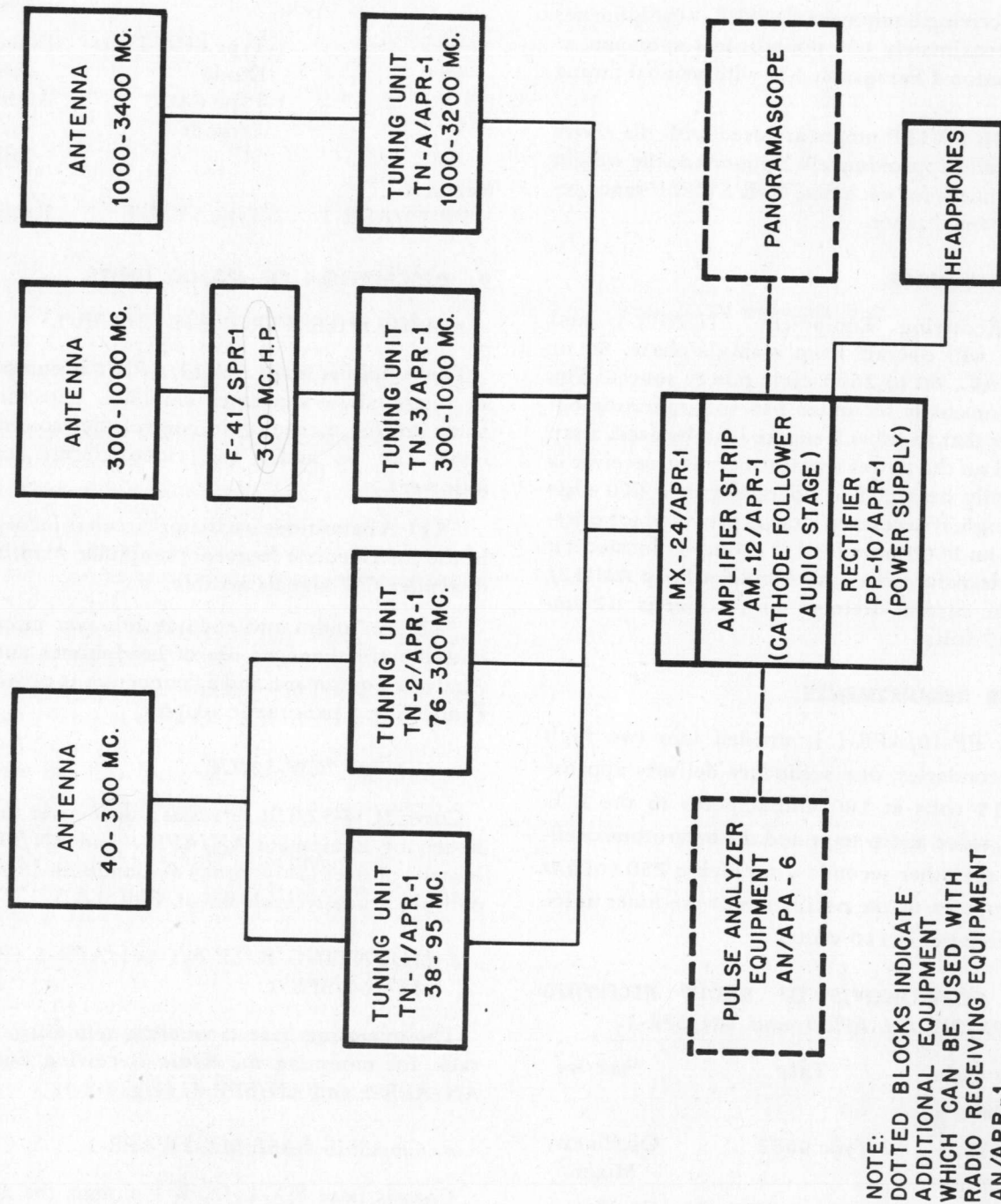

Figure 1-2. Radio Receiving Equipment AN/APR-1 Block Diagram.



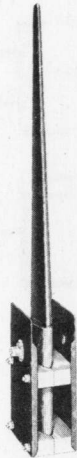

Figure 1-3. Stub Antenna AT-37/APT.



Figure 1-4. Stub Antenna AT-37A/APT.

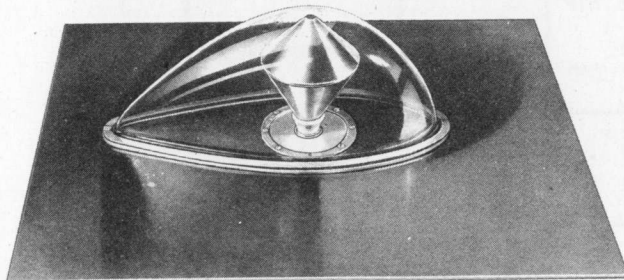

Figure 1-5. Cone Antenna AS-26/APR-2.

*e.* AIRBORNE ANTENNAE.

The antenna assemblies provided with Radio Receiving Equipment AN/APR-1 are of two types, a Stub Antenna, AT-37/APT, and a Cone Antenna, AS-26/APR-2.

(1) Type AT-37/APT or AT-37A/APT Stub Antenna; Fig. 1-3 and 1-4, consists of a phenolic impregnated maple mass 22.5 inches in length which has been plated with a thick layer of metal and mounted in a rectangular mount. The radiating metal plated area is connected to a type C-49269 receptacle for connecting to a 50 ohm coaxial cable, type RG-8/U. This type antenna will be used with Tuning Unit TN-1/APR-1 and TN-2/APR-1. (Fig. 1-2.)

Other stub antennae of this type are the AT-36/APT or AT-36A/APT, and the AT-38/APT or AT-38A/APT. In certain type installations one or more of these antennae may have been provided. The mountings are the same as that of the AT-37/APT so that they are interchangeable.

(2) The type AS-26/APR-2 Cone Antenna (Fig. 1-5), will be used to cover a frequency range from 300 to 1000 megacycles and is used with Tuning Unit TN-3/APR-1. (Fig. 1-2.)

The AS-26/APR-2 Cone Antenna is designed to have a wide frequency characteristic and may be mounted to receive either vertically or horizontally polarized radiation. If it is desired to receive both vertically and horizontally polarized radiation, the antenna should be mounted at an angle of 45 degrees with the vertical. The pickup is normally uniform in all directions perpendicular to the axis of the cone. The antenna pattern may vary with the installation; however, prototype installation data will usually be available.

When installed in aircraft, provision is made for covering the cone with a streamlined plastic nacelle. Connection to the receiver is through a 50 ohm coaxial cable, type RG-8/U.

(3) The AS-44/APR-5 or AS-125/APR Cone Antenna is a high frequency broad band antenna and will be used in installations where it is desirable to cover the frequency range of Tuning Unit TN-4A/APR-1 (1000 to 3200 mc.). A high pass filter with a cut-off frequency of 1000 megacycles follows the antenna and is made an integral part of the antenna structure. The antenna is connected to the receiver by a 50 ohm coaxial cable, type RG-8/U. This cable should be as short as possible, in keeping with good antenna installation practice and available receiver locations. (Fig. 6-39.)

*f.* SHIPBORNE ANTENNAE.

(1) The type AS-56/SPR-1 Dipole Antenna,

RESTRICTED  
AN-16-30APR-1-3  
NAVSHIPS 900, 483A

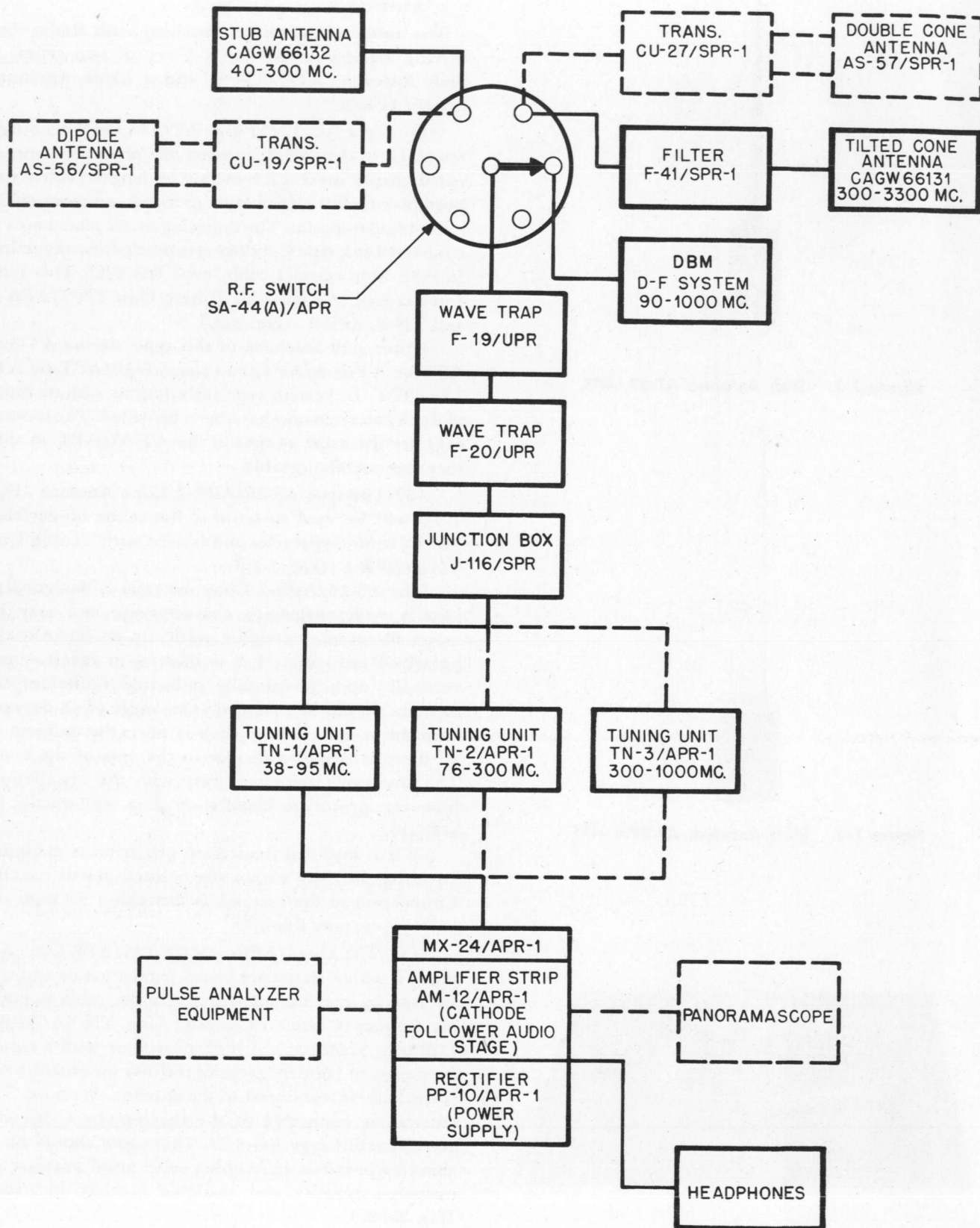

Figure 1-6. Radio Receiving Equipment AN/SPR-1, Block Diagram.

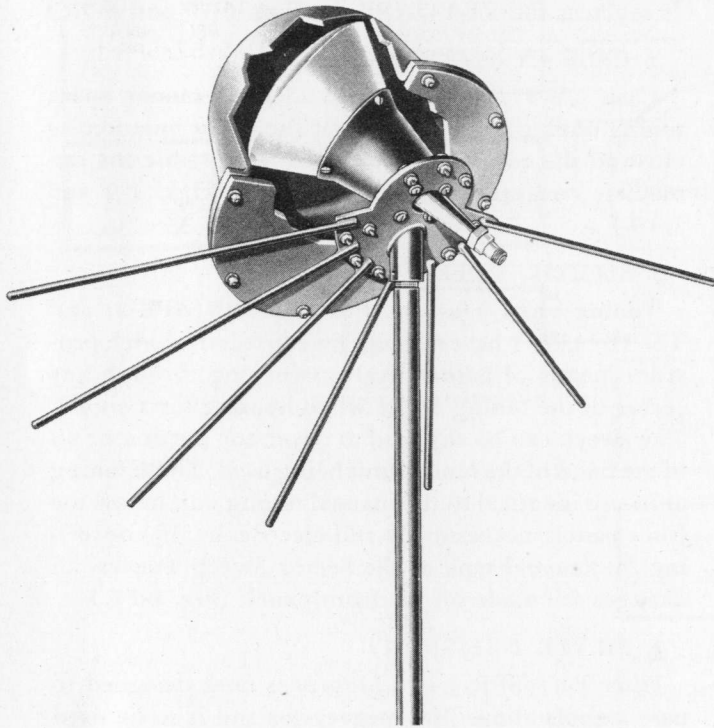

Figure 1-7. Antenna CAGW-66131.

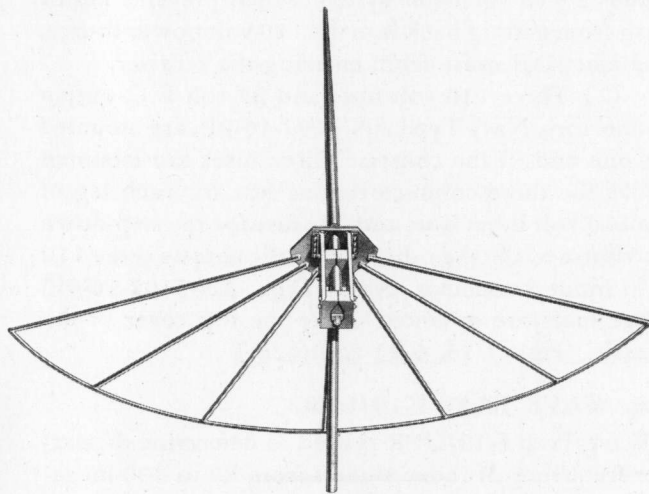

Figure 1-8. Antenna CAGW-66132.

(Fig. 6-30), consists of two aluminum cylinders seated in a wooden block. Each cylinder is connected to the center pin of a type CQA49470 receptacle. The two receptacles are mounted in the wooden block and connect to two RG-10/U cables.

The type CU-19/SPR-1 Impedance Matching Transformer, (Fig. 6-34), consists of several interconnecting coaxial lines of various impedances and matches two RG-10/U Coaxial Cables to one RG-10/U Coaxial Cable.

The above antenna assembly covers the range of Tuning Units TN-1/APR-1 and TN-2/APR-1.

(2) The type of AS-57/SPR-1 Double Cone Antenna, (Fig. 6-32), consists of two spun steel cones. Each cone is connected to the center pin of a type CQA49470 receptacle. The receptacles are mounted in the base of the antenna mount and are connected to two RG-10/U Cables.

The type CU-27/SPR-1 Impedance Matching Transformer, (Fig. 6-35), is similar in construction to Transformer CU-19/SPR-1.

The above assembly covers the range of Tuning Unit TN-3/APR-1.

(3) The type AS-44/APR-5 Cone Antenna, (Fig. 6-39), is provided with a ground plane for shipboard use. A high pass filter with a cut-off frequency of 1000 megacycles is part of the antenna structure. A type CQA49470 receptacle is provided for connecting an RG-10/U Cable or an adapter fitting for RG-17/U Cable. The AS-44/APR-5 Cone Antenna covers the frequency range of Tuning Unit TN-4A/APR-1.

(4) ANTENNA ASSEMBLY CAGW-66131.

The CAGW-66131 non-directional antenna was developed to operate with a range of 300 to 3300 megacycles, with a standing wave ratio of less than five to one. The non-directional antenna has a short null point at the back of the base. (Fig. 1-7.)

(5) ANTENNA ASSEMBLY CAGW-66132.

The CAGW-66132 non-directional antenna was developed to operate with a range of 40 to 300 megacycles, with a standing wave ratio of less than five to one. The non-directional antenna has a partial short null point at the front, and a sharp null point at the back. (Fig. 1-8.)

g. R. F. SWITCH SA-14/SPR-1.

R. F. Switch SA-14/SPR-1 (Fig. 6-38), is used on shipboard for the purpose of switching in the proper antenna for the frequency at which the receiver is being operated.

b. R. F. SWITCH SA-44(A)/APR.

R. F. Switch SA-44(A)/APR is used on shipboard for the purpose of switching in the proper antenna for

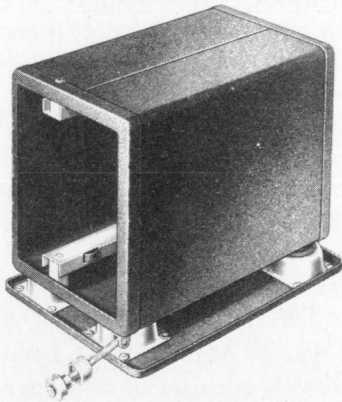

Figure 1-9. Case CY-57/APR-1.

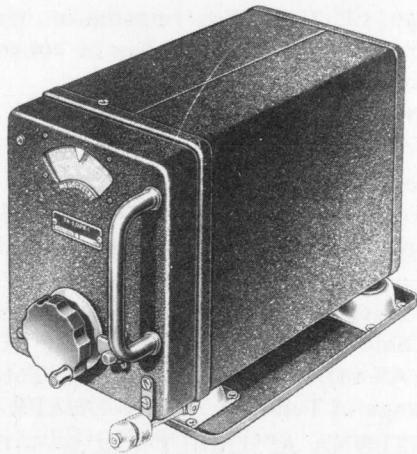

Figure 1-10. Case CY-57/APR-1 with Tuning Unit.

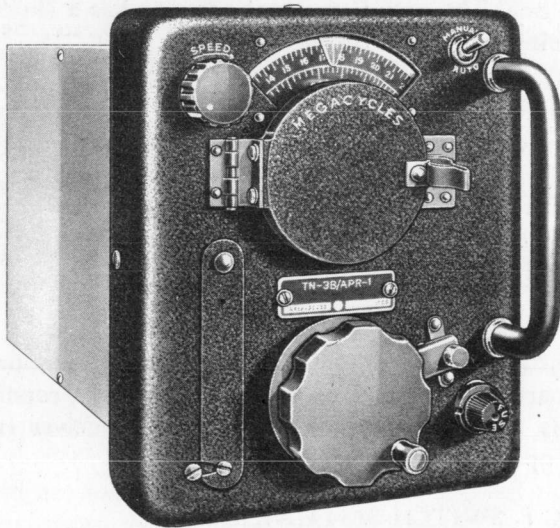

Figure 1-11. Sector Sweep Tuner, Front Panel.

the frequency at which the receiver is being operated. It replaces the SA-14/APR-1. (Figs. 6-77 and 6-78.)

*i.* CASE CY-57/APR-1.

Case CY-57/APR-1 is provided to mount spare tuning units when not in use. It should be mounted as close to the receiving equipment as possible for immediate conversion when necessary. (Figs. 1-9 and 1-10.)

*j.* SECTOR SWEEP TUNERS.

Tuning units TN-1B/APR-1, TN-2B/APR-1, and TN-3B/APR-1 have a Sector Sweep feature which provides means of automatically sweeping through any sector of the tuning range when hunting for a signal. The sweep can be adjusted to cover any portion or all of the band of the tuning unit being used. These tuning units are identical to the manual tuning unit below the front panel, mechanically and electrically. In converting the manual type to the Sector Sweep Tuners, all changes are made on the front panel. (Fig. 1-11.)

*k.* FILTER F-41/SPR-1.

Filter F-41/SPR-1 is a high pass filter designed to pass signals above 300 megacycles and is to be used with Tuning Unit TN-3/APR-1. This filter eliminates interference from radars below 300 mc. (Fig. 1-12.)

*l.* RECTIFIER—FILTER UNIT PP-183/SPR-1.

(1) Rectifier—Filter Unit PP-183/SPR-1 converts a 110 volt A.C. power source to 28 volts D.C. to operate the motors of the Sector Sweep Tuners of Radio Receiver AN/APR-1 and AN/SPR-1. A power outlet is also provided for the AN/SPR-2 Receiver. It includes a 110 volt filter system which prevents motor hash from getting back into the 110 volt power source, and electrical noise from entering the receiver.

(2) Three 110 volt filter and 28 volt D.C. output connectors, Navy Type AN-3102-16-9P, are mounted on one end of the chassis. Three fuses are mounted above the three connectors; one fuse for each leg of the 110 volt input line, and one fuse for the step-down transformer. On the other end of the chassis is the 110 volt input connector Navy Type AN-3102-16-9P. Spare fuses are mounted under the top cover of the chassis. (Figs. 1-13, 6-25 and 6-26.)

*m.* WAVE TRAP F-19/UPR.

Wave Trap F-19/UPR is used to determine the carrier frequency of radar signals from 80 to 300 megacycles. It helps to distinguish true signals from harmonic or spurious responses in the receiver (Fig. 1-14.) It is recommended that the F-19/UPR be used in conjunction with Wave Trap F-20/UPR. The F-19/UPR consists of a tunable resonant circuit connected across a transmission line. When the circuit is tuned

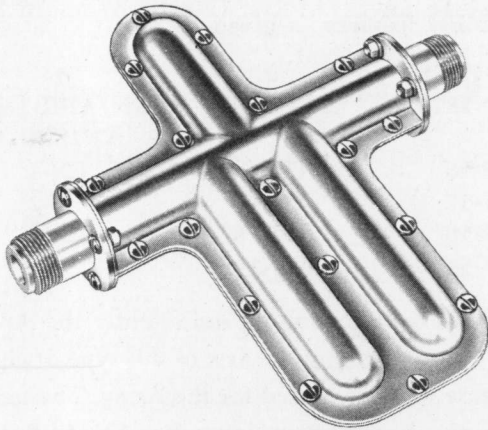

Figure 1-12. Filter F-41/SPR-1.

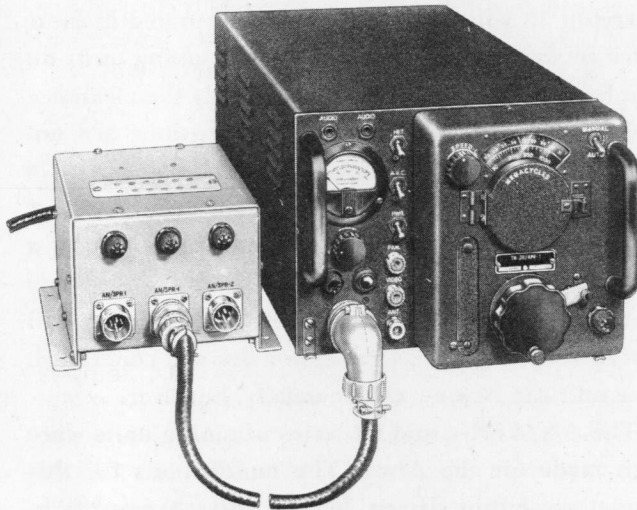

Figure 1-13. Rectifier Filter PP-183/SPR-1, with Receiver.



Figure 1-14. Wave Trap F-19/UPR.

to the incoming signal, the resulting low impedance produces a sharp null in the receiver output. (Fig. 1-14.)

*n.* WAVE TRAP F-20/UPR.

Wave Trap F-20/UPR is used to determine the carrier frequency of radar signals from 300 to 3,400 megacycles. It helps to distinguish true signals from harmonic or spurious responses in the receiver. Wave Trap F-20/UPR is a shorted half-wave coaxial stub which is connected in the receiver input circuit.

The electrical length of the stub is varied by a tuning slider. When the F-20/UPR is tuned to the frequency of an incoming signal, the low impedance produced at the point of connection to the antenna cable gives a sharp null in the receiver output. (Fig. 1-15.)

*o.* JUNCTION BOX J-116/SPR.

Junction Box J-116/SPR is used to switch antennae from the AN/SPR-1 to other receivers. It has a 0.2 db. loss at 3500 mc. and is designed to operate over the frequency range of 40-4000 mc.

**10. ASSOCIATED EQUIPMENT.**

*a.* PANORAMIC ADAPTER RDP.

The panoramic adapter is an instrument containing a cathode ray tube, and incorporating an electronic sweep circuit and several stages of I. F. amplification at 30 megacycles. When coupled, by means of a concentric line, into Radio Receiving Equipment AN/APR-1 and AN/SPR-1, a band width up to 6 mc. can be received on the CRT. Any signals present in this band, in the intermediate frequency amplifier of Radio Receiving Equipment AN/APR-1 and AN/SPR-1, generate pulses of D.C. which are applied to the vertical plates of the cathode ray tube. Since this tube has also applied to it (on the horizontal plates) a sawtooth wave corresponding to the sweep rate, the signals result in vertical pips being produced on the tube. The number of pips correspond to the number of signals; the size, or height, corresponds to the strength. Modulation, if present on the signal, can also be seen on the scope. Pulse signals as close in absolute frequency as .2 mc. can be distinguished. (See Instruction Book pertaining to the RDP for specific operating instructions.)

*b.* PULSE ANALYZER EQUIPMENT RDJ.

Pulse Analyzer Equipment contains a video amplifier, multi-vibrator, sawtooth oscillator, calibrate oscillator, pulse motor, and oscilloscope. When it is used with the Radio Receiving Equipment AN/APR-1, signals normally inaudible in the headphones can be seen on the cathode ray tube, in a manner similar to that explained under Section I paragraph 10 *a.* For this reason, when the Radio Receiving Equipment

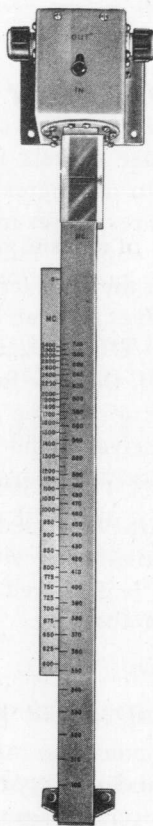

Figure 1-15. Wave Trap F-20/UPR.

AN/APR-1 and AN/SPR-1 is used with the Pulse Analyzer Equipment, more dependence should be placed on the latter instrument than on the audible response. The pips produced on Pulse Analyzer Equipment represent the duration of the pulse in microseconds; the repetition rate in cycles per second is indicated by a meter on the front panel of the equipment. (See Instruction Book pertaining to the RDJ for specific operating instructions.)

c. USE OF THE RADIO RECEIVING EQUIPMENT AN/APR-1 AND AN/SPR-1 WITH OTHER SIMILAR EQUIPMENTS.

There are several different versions of the AN/APR-1 and AN/SPR-1 equipment which have been in use for some time. Each new version represents an improvement over the one preceding it, but in general the differences are not of a nature such that the feature of interchangeability has been lost. There follows below a list of these various existing equipments, after which a commentary on the differences, explaining what

changes are necessary to effectively utilize the interchangeability features, is given.

1. ARC-1 (SCR-587)	2. AN/APR-4	3. AN/APR-1 and AN/SPR-1
TU-56	TN-16	TN-1
TU-57	TN-17	TN-2
TU-58	TN-18	TN-3
TU-59	TN-19	

The TU series (for tuning units under the ARC-1 (SCR-587) were among the first of this type of equipment. These were produced for the Army. The tuning units cannot be plugged into the AN/APR-4 or AN/APR-1 and AN/SPR-1 chassis unless a third hole is drilled into the rear of the casting to clear a plug carrying 28 volts D-C which is incorporated in these later versions. Since the TU series of tuning units do not have the motor driven feature, only the clearance hole is required, all the other dimensions are unchanged. Any of the tuning units for the AN/APR-4 and AN/APR-1 or AN/SPR-1 can be used in ARC-1 (SCR-587) except that those tuning units having a motor drive designed to receive the 28 volts supply power through the plug at the rear of the casting will not operate, insofar as the motor drive is concerned. The unit can be operated manually, however.

The AN/APR-4 and its series of tuning units were also made for the Army. The tuning units for this model are motor driven, but are interchangeable in every respect with the AN/APR-1 and AN/SPR-1. It should be noted that, in the AN/APR-1 and AN/SPR-1, provision is made to excite the motors with 28 volts (D-C) through a plug connection at the rear of the casting. The 28 volt lead from this plug is brought out to the front panel of the receiver, and must be connected if the motor driven tuning unit is to be used. The tuning units for the AN/APR-1 and AN/SPR-1 (viz. TN-1, TN-2, TN-3) can be used in the AN/APR-4 with no change whatever. The difference between the two models is chiefly the I. F. bandwidth, which is fixed in the AN/APR-1 and AN/SPR-1, and variable in two steps in the AN/APR-4. Essential dimensions do not differ in the two units.

A limited number of tuning units bearing the numbers TN-2A and TN-3A have been made. These are motor driven and can be used in any of the equipments shown in the table, except as noted above.

AURIE S. MYERS, JR.  
1512 IVY LANE  
RALEIGH, N. C. 27609

## SECTION II — INSTALLATION AND ADJUSTMENT

### 1. GENERAL.

a. Before installation of the Radio Receiving Equipment AN/APR-1 and AN/SPR-1, the aircraft or ship engine, generator and accessories must be completely shielded and bonded if satisfactory results are to be obtained. It must be realized that the interference with the signal reception, produced by the radiation of electrical disturbances from the engine ignition system, charging generator, unbonded contacting metal surfaces, etc., bears no direct relation to the sensitivity of the radio receiver. The relative magnitude of such disturbances at the receiving antenna, in comparison with the incoming radio wave, is the factor of prime importance.

b. If the radio field intensity is equal to, or greater than, the local electrical noise level, reception will be possible on any radio receiver sensitive enough to operate on that radio field. The more sensitive the radio receiver, the weaker the radio signal which it will receive. Frequently a highly sensitive radio receiver is considered to be noisy when the aircraft or ship is in motion, simply because it will receive both radio signals and locate disturbances which are weaker than those receivable on a relatively insensitive receiver.

c. A complete job of bonding and shielding is achieved when weak radio signals can be received with the gain control set at maximum. No change in background noise should be noticed when the aircraft or ship is in motion, or with engines running, compared to the level of background noise present when the aircraft or ship is at rest.

### 2. RECEIVER INSTALLATION, GENERAL.

#### a. LOCATION.

In selecting a location for Radio Receiving Equipment AN/APR-1, the following points may be considered:

- (1) Proximity to antenna.
- (2) Proximity to associated equipment if such equipment is to be used. A semi-darkened position is preferred when Pulse Analyzer RDJ is to be used.
- (3) Accessibility for tuning.
- (4) Weight distribution.

(5) Keep length of transmission lines as short as possible, in order to prevent losses caused by long interconnecting cables.

(6) Avoid sharp bends in the concentric transmission lines and interconnecting cables.

### 3. SHIPBORNE INSTALLATION.

#### a. MOUNTING BASE MT-160/SPR-1.

Mounting Base MT-160/SPR-1 is mounted on a level plane, allowing  $\frac{3}{4}$  inch clearance in all directions for shockmount action. Allow 25 inches of clearance in front of the Mounting Base MT-160/SPR-1 for mounting and dismounting the receiver. See Figure 6-53 for mounting hole locations. The ground straps are secured under the mounting screws to provide a good electrical ground.

#### b. CARRYING CASE CY-57/APR-1.

Install Carrying Case CY-57/APR-1 in the same manner as indicated for the mounting base, allowing approximately 15 inches clearance for mounting and dismounting the spare tuning units. See Figure 6-54 for mounting hole locations.

#### c. RECEIVER INSTALLATION.

##### CAUTION:

*Be sure the receiver is set up for the voltage of the power source used, 80 or 115 volts. Terminal No. 11 of the power transformer T-201 is for 115 volt operation and terminal No. 10 is for 80 volt operation Figure 8-12.*

(1) Slide Radio Receiving Equipment AN/SPR-1 on mounting base until pins at the back of the cradle engage the holes in the back of the receiver case and chassis. Swing the left hand knurled nut on the mounting base up over the catch on the lower left hand corner of the receiver panel and hand tighten. Repeat this procedure for the right hand knurled nut. The receiver will then be locked in its mounting base, and the tuning unit in the receiver. (Fig. 1-1.)

(2) Insert the headphone plug (PL-55) into the AUDIO jack on the front panel of Radio Receiving Equipment AN/SPR-1. Two jacks are provided, connected in parallel, so that an auxiliary headset can be used.

d. CABLE INSTALLATION.

(1) POWER CABLE.

Use WF-10/U Cable with an AN-3108-22-4S plug and AN-3057-12 adapter attached. This plug fits into the power receptacle P-301 on the receiver. The other end should terminate in a suitable terminal box on an AN-3108-22-4P or AN-3106-22-4P plug together with an AN-3102-22-4S power receptacle. This end connects to the 80 volt A.C. or 115 volt A.C. and 28 volt D.C. power source; or may be connected to Rectifier Unit PP-183/SPR-1. (See Section II, paragraph 3 b).

**NOTE:**

*Power connector AN-3108-22-4S lettered A, B, C, D. Pin A, white lead, 115V. A.C., pin B, green lead, 28V, D.C., Pin C, red lead 115V. A.C., and pin D, black lead, ground.*

(2) ANTENNA CABLE.

Use RG-10/U Cable (armored) terminating at both ends with UG-21/U Plugs. UG-27/U right angle adapters may be used if necessary to eliminate sharp bends in the cable. The bend radius should not be less than four inches. The cables must be securely clamped throughout their entire length and routed as directly as possible.

e. ANTENNAE INSTALLATION.

**WARNING:**

*Antennae installations are most important for operation of the receiver. USE ONLY THE ANTENNAE DESCRIBED IN THIS MANUAL. Install antennae high on ship's rigging. Remember each foot of altitude gained increases the receiver range approximately ONE MILE, up to certain limits. Keep lead in R-F cables to a minimum length (other than vertical) to prevent losses.*

(1) ANTENNA CAGW-66131.

Antenna Assembly CAGW-66131 mounting should be on the yardarm or in front of the mast, and mounted as high as possible to avoid shadow effects. The mounting column is 1½ inches standard steep pipe, 22 inches long. The axis of the yardarm and the axis of the mounting column are to be at an angle of 90 degrees. The antenna ground is through the mounting column. A connector at the base of the antenna accommodates a UG-21/U plug for connecting the antenna cable. (Fig. 1-8.)

(2) FILTER F-41/SPR-1.

Connect Filter F-41/SPR-1 between antenna cable and R. F. Switch SA-44(A)/APR.

(3) ANTENNA CAGW-66132.

Antenna CAGW-66132 mounting should be on the yardarm in front of the mast, and mounted as high as possible to avoid shadow effects. The mounting is a 1½ inch standard steel pipe, 22 inches long. The axis of the yardarm and the axis of the mounting column are to be 90 degrees and perpendicular to the deck. The antenna ground is through the mounting column. A UG-58/U panel receptacle at the base of the stub mast accommodates a UG-21/U plug.

(4) DIPOLE ANTENNA AS-56/SPR-1.

Dipole Antenna AS-56/SPR-1 is provided with a pipe which facilitates mounting to a yardarm and is used with Impedance Matching Transformer CU-19/SPR-1. (Fig. 6-30.)

(5) DOUBLE CONE ANTENNA AS-57/SPR-1.

Double Cone Antenna AS-57/SPR-1 is provided with a flat plate mounting and is used with Impedance Matching Transformer CU-27/SPR-1. (Fig. 6-31.)

(6) Impedance Matching Transformers are supplied with clamps for mounting. They may be mounted on the mast or near the receiving position. If installation is made in the open, suitable precautions must be maintained to insure that the units are kept water-tight.

**NOTE:**

*For reception of signals of either horizontal or vertical polarizations, it is recommended that two dipole or double cone antennae be tilted at an angle of 45 degrees with the vertical. For maximum reception at all azimuths, the axis of the antennae should be at 90° to each other and 45° port or starboard of the ship's centerline.*

(7) Single Cone Antenna AS-44/APR-5 or AS-125/APR is provided with a ground plane to adapt the unit for shipboard use.

f. SWITCH SA-44(A)APR.

Switch SA-44(A)/APR is mounted on a bracket or bulkhead and is connected between the antennae and the wave traps, Fig. 1-3. The location should be near the receiver so as to be convenient to the operator.

g. WAVE TRAPS F-19/UPR AND WAVE TRAP F-20/UPR.

Connect Wave Traps F-19/UPR and F-20/UPR in series between Switch SA-44(A)/APR and the receiver, Fig. 1-3.

b. J-116/SPR R.F. JUNCTION BOX (40-4000 M. C.).

In order to switch antennas to the RDO receiver or to other receivers, a specially designed R.F. junction



box is used which has less than 0.2 db. loss at frequencies of 3500 mc. With "N" type connectors on either RG-8, 10 or 18/U Cable the various antennas may be connected to the jack box, and by RG-8 or 10/U Cables (with the special R.F. Jack box connectors provided) connected to the receiver. With this R.F. Jack box, any antenna may be plugged into any receiver.

*i.* RECTIFIER-FILTER PP-183/SPR-1.

(1) Mount Rectifier-Filter Unit PP-183/SPR-1 in any convenient location adjacent to the receivers allowing for a minimum length of cable. (Fig. 1-13.)

(2) Interconnect the Rectifier-Filter PP-183/SPR-1 to Radio Receiver AN/APR-1 or AN/SPR-2 using WF-10/U cable with Navy Type AN-3106-16-9S connectors and the regular receiver power plug at the receiver end. Two of the output connectors on the Rectifier-Filter Unit PP-183/SPR-1 are intended for AN/SPR-1 and for AN/SPR-2.

(3) Cables are wired to the AN-3106-16-9S and AN-3057-8 cable clamps as follows:

- Terminal A—red lead—positive, D.C.
- Terminal C—black lead—negative, D.C.
- Terminal B—white lead—A.C.
- Terminal D—green lead—A.C.

The WF-10/U cable from the power source is connected to terminals B and D or the AN-3102-16-9S connector and connected to the input connector on the chassis.

**4. AIRBORNE INSTALLATION.**

*a.* MOUNTING BASE MT-141A/APR-1.

Mounting Base MT-141A/APR-1 is mounted so that the equipment is approximately level during normal flight. Allow  $\frac{3}{4}$  inch clearance in all directions for shockmount action and 25 inch clearance in front for mounting and dismounting the receiver. See Fig. 6-53 for mounting hole locations. The ground straps are secured under the mounting screws to provide a good electrical ground.

*b.* CARRYING CASE CY-57/APR-1.

Install Carrying Case CY-57/APR-1 in the same manner as indicated for the mounting base, allowing approximately 15 inch clearance for mounting and dismounting the spare tuning units. See Fig. 6-54 for mounting hole locations.

*c.* RECEIVER INSTALLATION.

**CAUTION:**

*Be sure the receiver is set up for operation at the voltage of the power source available, 80 or 115 volts. Terminal No. 11 of the power transformer T-201 is for 115 volt operation and terminal No. 10 is for 80 volt operation. (Fig. 8-12.)*

(1) Slide Radio Receiving Equipment AN/APR-1 on mounting base until pins at the back of the cradle engage the holes in the back of the receiver case and chassis. Swing the left hand knurled nut on the mounting base up over the catch on the lower left hand corner of the receiver panel and hand tighten. Repeat this procedure for the right hand knurled nut. The receiver will then be locked in its mounting base, and the tuning unit in the receiver. (Fig. 1-1.)

(2) Insert the headphone plug (PL-55) into the AUDIO jack on the front panel of Radio Receiving Equipment AN/APR-1. Two jacks are provided, connected in parallel, so that an auxiliary headset can be used.

*d.* CABLE INSTALLATION.

(1) POWER CABLE.

Use WF-1/U cable with an AN-3108-22-4S plug and AN-3057-12 adapter attached. This plug fits into the power receptacle P-301 on the receiver. The other end should terminate in a suitable terminal box or an AN-3108-22-4P or AN-3106-22-4P plug together with an AN-3102-22-4S power receptacle. This end connects to the 80 volt A.C. or 115 volt A.C. and 28 volt D.C. power source; or may be connected to Rectifier Unit PP-183/SPR-1. (See Section II, paragraph 3 *i*). The length of the cable will be determined by the proximity of the receiver to the power source.

**NOTE:**

*Power connector AN-3108-22-4S has four pin terminals lettered A, B, C, D. Pin A, white lead, 115 v. A.C., Pin B, green lead, 28 v. D.C., Pin C, red lead, 115 v. A.C., and Pin D, black lead, ground.*

(2) ANTENNA CABLE. (Figs. 6-69 and 6-70.)

Use RG-8/U cable terminating at both ends with UG-21/U Plugs. UG-27/U right angle adapters may be used if necessary to eliminate sharp bends in the cable. The bend radius should not be less than four inches. The cable must be securely clamped throughout its entire length and routed as directly as possible.

*e.* ANTENNA INSTALLATION.

(1) GENERAL.

Paint and corrosion must be removed from surfaces on which antennas are installed to insure a good ground. Shims of plywood with a metallized surface or an approved equivalent shall be used whenever it is necessary to adapt the flat bases of the AS-26/APR-2 or AS-124/APR to a curved airplane surface.

Where it is necessary to pass cables through bulkheads, such cable must be protected against damage from sharp edges of metal around the hole in the bulkhead.

**CAUTION:**

*No component parts of the AN/APR-1 with the exception of Cone Antennae AS-26/APR-2 or AS-124/APR—or Nacelle CW-3/APR shall be mounted directly on the skin of the aircraft.*

(2) STUB ANTENNA AT-37/APT OR AT-37A/APT.

(a) The stub antenna is mounted on the underside of the aircraft. Do not mount it near any projecting metal objects and keep it as free of shielding from the ground as possible. The antenna is mounted at an angle of 45°, plus or minus 5°, with the plane of flight and shall be as nearly perpendicular as possible to a plane tangent to the point of mounting. The antenna shall clear the ground by at least six inches under any extreme of a normal landing including flat tires. The cable routing distance from the antenna to the receiver shall not exceed forty five feet. (Fig. 6-55.)

(b) Stub Antennae AN-36/APT—or AN-36A/APT, AN-38/APT or AN-38A/APT are mounted in the same manner as Stub Antenna AN-37/APT.

(3) CONE ANTENNA AS-26/APR-2.

Cone Antenna AS-26/APR-2 is mounted according to the requirements given for Stub Antenna AT-37/APT, Section II paragraph 4 e (2) (a), except that it must not be farther than twenty-five feet from the receiver. See Fig. 000 for mounting hole locations.

(4) CONE ANTENNA AS-124/APR.

Cone Antenna AS-124/APR is mounted according to the requirements given for Stub Antenna AT-37/APT, Section II paragraph 4 e (2) (a), except that it must not be farther than twenty-five feet from the receiver. See Fig. 6-56 for mounting hole locations.

(5) NACELLE CW-3/AP.

Nacelle CW-3/AP will cover either the AS-26/APR-2 or AS-124/APR antennae. Gaskets of neoprene or equivalent material is used between the nacelle and the fairing or aircraft skin, as the case may be, and between the nacelle and its clamping ring. A hole of 3/16 inch diameter must be drilled at the lowest point of the nacelle for drainage. Nacelle CW-3/AP and the antenna must be placed where they are least likely to be struck by rocks thrown up by the wheels.

If Nacelle CW-3/AP is mounted on a curved surface, a suitable fairing should be used. It must be of minimum height and not extend beyond the inside cone of apex. (Fig. 6-59.)

(6) FILTER F-41/SPR-1.

Filter F-41/SPR-1 is connected between the antenna cable and the receiver when the unit is operating with Tuning Unit TN-3/APR-1.

**5. TEST EQUIPMENT.**

The following list of test equipment is required for performing the tests specified in Section II, paragraphs 6, 7, and 8.

TS-47/AP Test Oscillator

ONAN type 100-B Motor Alternator, or type 800-C Motor Alternator if a 28 v. D.C. supply is available.

TS-34/AP Oscillator or equivalent.

Signal Generators GR-804-C

or Meas. Corp. 80 LAF

or Meas. Corp. 84 LAG

Vacuum Tube Voltmeter.

RCA 165 Volt-Ohmst Jr.

or equivalent.

**6. PRE-INSTALLATION TEST AND ADJUSTMENTS.**

*a. GENERAL.*

(1) A test setup should be provided such that the receiving equipment may be connected to a power source of the same voltage and frequency as that of the aircraft or ship in which it is to be installed, and such that it may be connected to the same type antenna with which it is to be used.

(2) This equipment is designed to operate from 60 to 2600 cycles, 80 or 115 volts A.C.  $\pm 5\%$  and 26.5 volts D.C.  $\pm 10\%$ . In all operation tests, the equipment should be operated from a power-source of the same voltage and frequency as that supplied by the plane or ship in which the equipment is used.

*b. OPERATION CHECK.*

(1) CONTROLS.

All controls shall be checked for ease of operation. They shall operate freely without binding or other malfunctioning. Manual and motor drive tuning, operation of magnetic clutch and motor reversing switch shall be checked. When the electric drive is not in use, the clutch shall release so that the unit tunes freely with the manual control.

(2) PERFORMANCE.

The equipment shall be connected to the correct voltage source and the proper antenna for the frequency of the tuner in use. The equipment shall be allowed to warm up for 10 minutes. Using the test equipment listed in Section II, paragraph 5, the receiver shall be tested for operation over the complete frequency range of all tuning units. The frequency calibrations of all tuning units shall be accurate to  $\pm 2\%$ . The GAIN control shall be checked for proper

control of signal intensity. Operation of the AVC circuit shall be checked by switching the AVC, switch to the "ON" and "OFF" positions. The VIDEO output shall be connected into the oscilloscope to see that the circuit is functioning.

(3) NOISE CHECK.

All tuning units, manual or motor drive, will be checked for noise in accordance with the following:

Connect a signal generator to the input of the AN/APR-1 and AN/SPR-1 receiver through a 10 inch length of RG-8/U Cable. Set the signal generator for 30% modulation at 400 cycles. Connect the output of the receiver video into the vacuum voltmeter, shunted with a 1000 ohm resistor. The receiver output should be at least twice the noise level under the following conditions.

<i>Tuning Unit</i>	<i>Frequency</i>	<i>Signal Intensity</i>
TN-1, 1A or 1B	65 mc.	50 microvolts
TN-2, 2A or 2B	150 mc.	100 microvolts
TN-3, 3A or 3B	650 mc.	150 microvolts

When testing motor drive units, the motor drive motor shall be running.

7. OPERATIONAL CHECK.

NOTE:

*The procedure outlined herein shall be performed to determine that the equipment is operating in conjunction with the antenna, cabling and auxiliary equipment when it is to be used in the air craft or ship.*

a. Turn on the equipment and allow to warm up for 10 minutes after which the following checks shall be made.

(1) Using the TS-47/AP Test Oscillator as a signal source, check to see that signals may be picked up from all antennas installed for use with the AN/APR-1 and AN/SPR-1 receivers.

(2) Check operation with all auxiliary equipment to see that overall system operation is satisfactory. A signal just audible in the headphones shall furnish sufficient signal to operate the pulse analyzer and panoramic adapter if the units are installed.

(3) Repeat tests outlined in Section II, paragraph 6 b with aircraft or ship motors running and other electronic equipment installed in operation to see that no undue noise is present. Direct pickup of transmitters operating on the receiver frequency will not be considered as noise.

**8. TEST CHECK LIST.**

Date.....

AN/APR-1 and AN/SPR-1 Receiver Serial No.....

	<i>Standard Limits</i>	<i>Measured Value</i>	<i>Unsatisfactory</i>
<b>a. PRE-INSTALLATION TESTS</b>			
(1) Supply Voltage			
(a) D.C.....	28V± 5V		
(b) A.C.....	115V± 11V		
(2) Controls			
(a) Tuning.....	Satisfactory		
(b) I. F. GAIN control.....	Satisfactory		
(c) AVC switch.....	Satisfactory		
(d) Heterotone oscillating switch...	Satisfactory		
(e) Power Switch.....	Satisfactory		
(f) Pilot Light.....	Satisfactory		
(g) Motor Drive			
1. Operation.....	Satisfactory		
2. Clutch release.....	Satisfactory		
(3) Performance			
(a) Frequency coverage			
1. TN-1, 1A, 1B.....	38-95 mc.		
2. TN-2, 2A, 2B.....	76-300 mc.		
3. TN-3, 3A, 3B.....	300-1000 mc.		
4. TN-4A.....	1000-3200 mc.		
(b) Audio output.....			
(c) Video output.....			
(d) GAIN control.....			
(e) AVC operation.....			
(f) Heterotone osc. operation.....			
(g) Panoramic output.....			
(4) Noise Test.....	Maximum input for 2 x Noise output		
(a) TN-1, 1A, 1B Freq. 65 mc.....	50 microvolts		
(b) TN-2, 2A, 2B Freq. 150 mc.....	100 microvolts		
(c) TN-3, 3A, 3B Freq. 650 mc.....	150 microvolts		
<b>b. OPERATIONAL CHECK</b>			
(1) Antennas operating.....	Signal pick-up		
(2) Video output.....	Pulse present on analyzer		
(3) Panoramic output.....	Signal present on panoramic adapter		
(4) Audio output.....	Signal present in headphones		
(5) Plane or ship motors in operation.			
(a) TN-1, 1A, 1B Freq. 65 mc.....	50 microvolts		
(b) TN-2, 2A, 2B Freq. 150 mc.....	100 microvolts		
(c) TN-3, 3A, 3B Freq. 650 mc.....	150 microvolts		

## SECTION III — OPERATION

### WARNING:

*Operation of this equipment involves the use of high voltages which are dangerous to life. Operating personnel must at all times observe all safety precautions.*

### 1. DESCRIPTION OF CONTROLS.

#### a. RECEIVER.

##### (1) AVC SWITCH AND GAIN CONTROL.

The AVC switch controls the action of the automatic volume control circuit, and should be left in the AVC "ON" position. Its function is to automatically control the output of the receiver, and maintain that output constant, while the input may vary in strength. In certain cases it is desirable to be able to remove this function and resort to manual gain control. This is accomplished by turning the AVC switch to the "OFF" position, and operating the GAIN control. (Fig. 00-00.) *Extreme care should be used while receiving a signal to keep the manual gain control at as low a setting as possible, so that the tuning meter will not read over half scale. If this is not done, overloading will take place in the receiver which may give false indications, and false information, as to the characteristics of the received signal.* The effect of this overloading should be carefully noted while using the Pulse Analyzer Equipment.

##### (2) TUNING METER.

The tuning meter is used for the purpose of determining the relative strength of various signals. It may also be used to determine the direction from which the signal is received by noting the variation in signal strength as the antenna is rotated. (Fig. 3-1.)

##### (3) HETEROTONE OSCILLATOR SWITCH.

The heterotone oscillator is used only for reception of unmodulated CW signals. It will render them audible by modulating them at a frequency of 1000 cycles per second, and is controlled by means of a switch marked "HET" on the front panel. (Fig. 3-1.)

##### (4) PILOT LIGHT AND FUSE.

Operation of the unit is indicated by the pilot lamp on the front panel. In the event the pilot lamp fails to operate, the fuse should be removed and examined, and replaced if necessary. The fuse is replaced by unscrewing the cap marked FUSE located on the front panel of the receiver. (Fig. 3-1.)

### NOTE:

*Spare fuses and spare pilot lamps are provided at the rear of the tuner housing, inside the receiver.*

#### b. TUNING UNIT.

##### (1) LOCKING DEVICE.

On the tuning units, a locking device is provided which may be used to lock the dial to any specific frequency desired. For all ordinary conditions of search operation, this locking device should be left in the open position. Early production tuners do not have this device. (Fig. 3-2.)

##### (2) SECTOR SWEEP TUNERS.

(a) The Sector Sweep Tuner operates from a 28 volt, D-C power source, at .5 ampere. It will automatically hunt back and forth across the desired frequency range as set up by the operator. It can be made to cover the entire band or down to a minimum sector of 20 degrees on the dial.

(b) To adjust the tuner, push the snap spring to the right on the front cover. The cover will then automatically open and the adjustment pointers are accessible. The pointers are provided with two knurled nuts for locking the pointers in position. Loosen the nuts and set the pointers to the end frequencies of the range to be swept. Tighten the nuts and close the front cover. (Fig. 3-2.)

##### (c) SPEED CONTROL.

The SPEED control varies the speed of the Sector Sweep motor permitting the operator to slow down the speed of sweep and increase the possibilities of picking up weak signals. (Fig. 3-2.)

##### (d) AUTO-MANUAL SWITCH.

When the tuner switch is in the AUTO position, the tuner will automatically sweep the frequency range at which it is set, see Section III, paragraph 1 b (2)

(b). When it is desirable to tune manually, set switch in the MANUAL position. (Fig. 3-2.)

##### (e) FUSE

If the tuning unit fails to operate, check fuse and replace if burned out.

### 2. OPERATION (Fig. 3-1 and 3-2.)

a. Ascertain that the tuning unit covering the frequency range desired is in position, that the headphones are plugged in and that all the power and antenna cables are properly connected.

b. When using R. F. Switch SA-44(A)/APR or R. F. Switch SA-14/SPR-1, be sure it is set for operation for the antenna covering the range of the tuning unit in use.

RESTRICTED  
AN-16-30APR-1-3  
NAVSHIPS 900, 483A

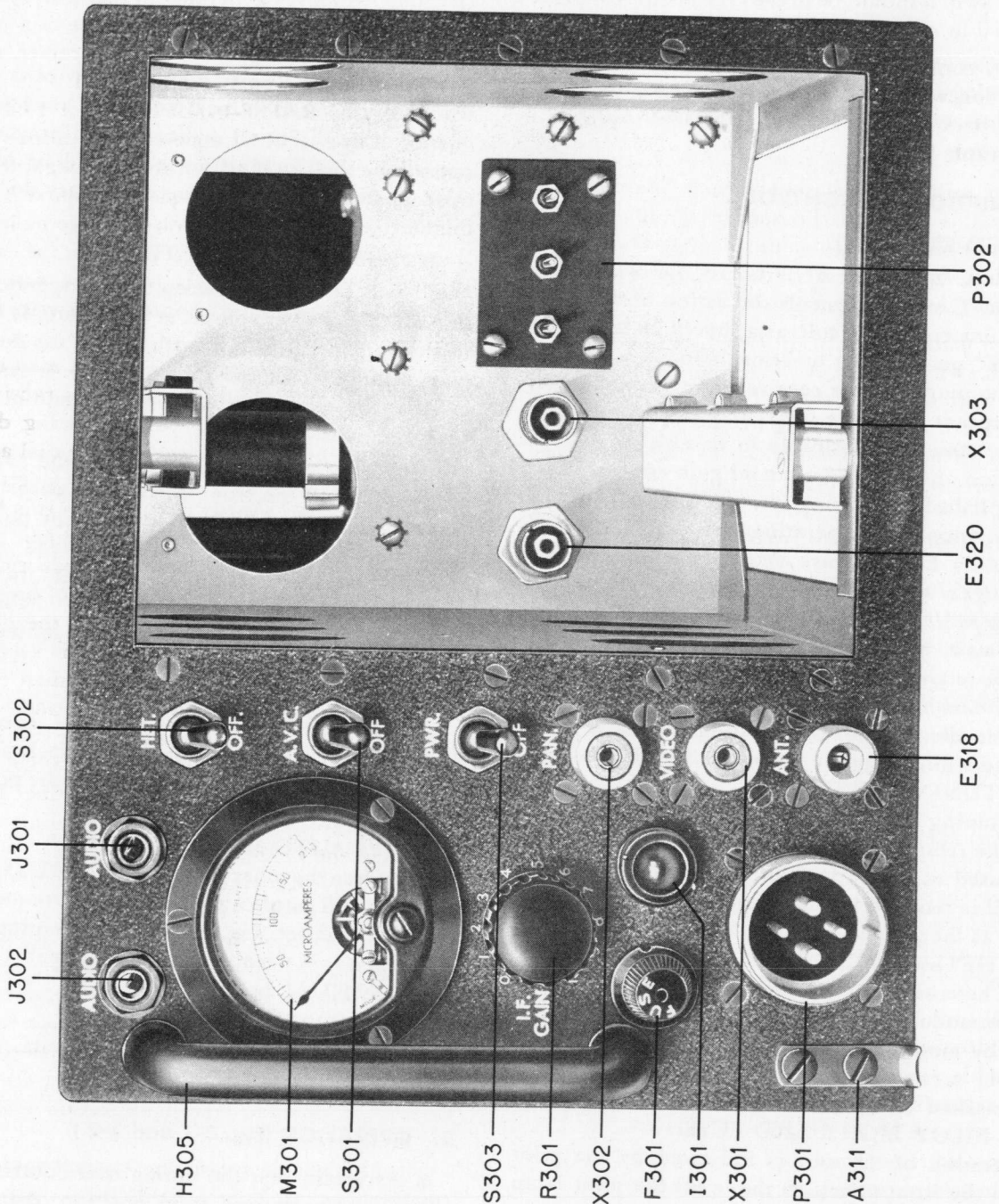

Figure 3-1. Amplifier Strip AM-12/APR-1 and Rectifier PP-10/APR-1 Front View.

c. Turn PWR-OFF switch to PWR position. Allow a 10 minute warm-up period. An audible hiss will be noted in the absence of a signal. This is an indication that the unit is in operation.

d. HET switch should be in the OFF position, unless it is desired to receive unmodulated CW signals.

e. GAIN control should be at the maximum clockwise position with AVC switch in ON or AVC position. For operation with AVC switch in AVC position see paragraph 1 a (1).

f. When using *manual* tuners, turn tuning knob until signal is received. Frequency of the received signal can be read directly on the dial. See Section III, paragraph 4, for checking signal for the correct frequency.

g. When using *Sector Sweep tuners*, set the AUTO-MANUAL switch to the AUTO position. The tuner will automatically tune through the range selected, reversing itself when reaching its end frequency. The possibility of missing a weak signal can be reduced by regulating the SPEED control. As soon as a signal is detected, switch the tuner to the MANUAL position and tune the signal in manually.

**WARNING:**

*Do not operate tuner manually with MANUAL-AUTO switch in AUTO position.*

**3. SIGNAL CHARACTERISTICS.**

The following characteristics of a signal must be determined in order to identify it properly.

- a. The signal strength.
- b. Duration of the pulse.
- c. Repetition rate.
- d. Pulse shape.
- e. Signal frequency.
- f. Steadiness of the carrier (steady or rate of fluctuation).

If a CW carrier is being investigated, only the signal strength, frequency, and the steadiness are to be determined. This analysis is accomplished by using the heterotone oscillator for the reception of these signals when they are CW telegraphy. In some cases, when many signals are grouped together, they can be separated with the use of the panoramic adapter.

**NOTE:**

*The above signal characteristics cannot be determined with Receiving Equipment AN/APR-1 and AN/SPR-1 alone except for relative frequencies and signal strength. Check Instruction Book on Pulse Analyzer and Panoramascope for specific operating instructions.*

**4. USE OF WAVE TRAPS TO DETERMINE EXACT SIGNAL FREQUENCY OF INCOMING SIGNAL.**

Some trouble has been experienced in determining the exact frequency of incoming signals because of spurious responses generated in the equipment in the presence of strong signals. By the use of a wave trap inserted between the antenna and receiver, the exact frequency of the signal is determined.

a. WAVE TRAP F-19/UPR. (Fig. 1-14.)

(1) Dependable frequency indications are obtained on the F-19/UPR up to 310 megacycles. Multiple nulls can occur on frequencies above 310 megacycles. It is also possible to observe two nulls on some frequencies below 310 megacycles, but the calibration of the F-19/UPR depends upon the first null encountered when tuning counter-clockwise, from low to higher frequencies.

(2) The switch on the F-19/UPR *must* be kept in the "OUT" position until a signal is received. This switch is coupled directly to the tuning dial. (Fig. 1-14) Rotating the calibrated tuning dial away from the "OUT" position automatically connects the wave trap to the antenna input circuit when it is desired to measure the carrier frequency of a signal.

(3) It is imperative that the procedure detailed in Section III, paragraph 4 a (4) be followed exactly when the F-19/UPR is used *without* the F/20-UPR. When the F-20/UPR is available, it is easy to prove whether the signal is greater or less than 310 megacycles. This removes any possibility of ambiguity from higher frequency signals when using the F-19/UPR and renders the precautions listed under the following paragraphs unnecessary. However, the F-19/UPR must always be tuned upward, beginning at the low frequency end of the calibration scale.

(4) The following sequence of operation should be used with the F-19/UPR:

(a) Check to make sure that the wave trap is switched "OUT" of the antenna circuit.

(b) Locate the signal on the receiver. It is desirable to record the frequency to which the receiver is tuned, the pulse width and the repetition rate of the signal at this time. The receiver again should be reduced if necessary to prevent saturation of the receiver and the pulse analyzer.

(c) Tune the wave trap slowly, beginning at the low frequency end of the calibration scale. If no null is encountered, the frequency of the incoming signal is not in the range 80-310 mc. If one or more nulls are obtained, the first null is assumed to be the correct frequency. Confirmation as described below is recommended.

(d) Retune the receiver to the signal frequency as indicated by the F-19/UPR. It is important to note

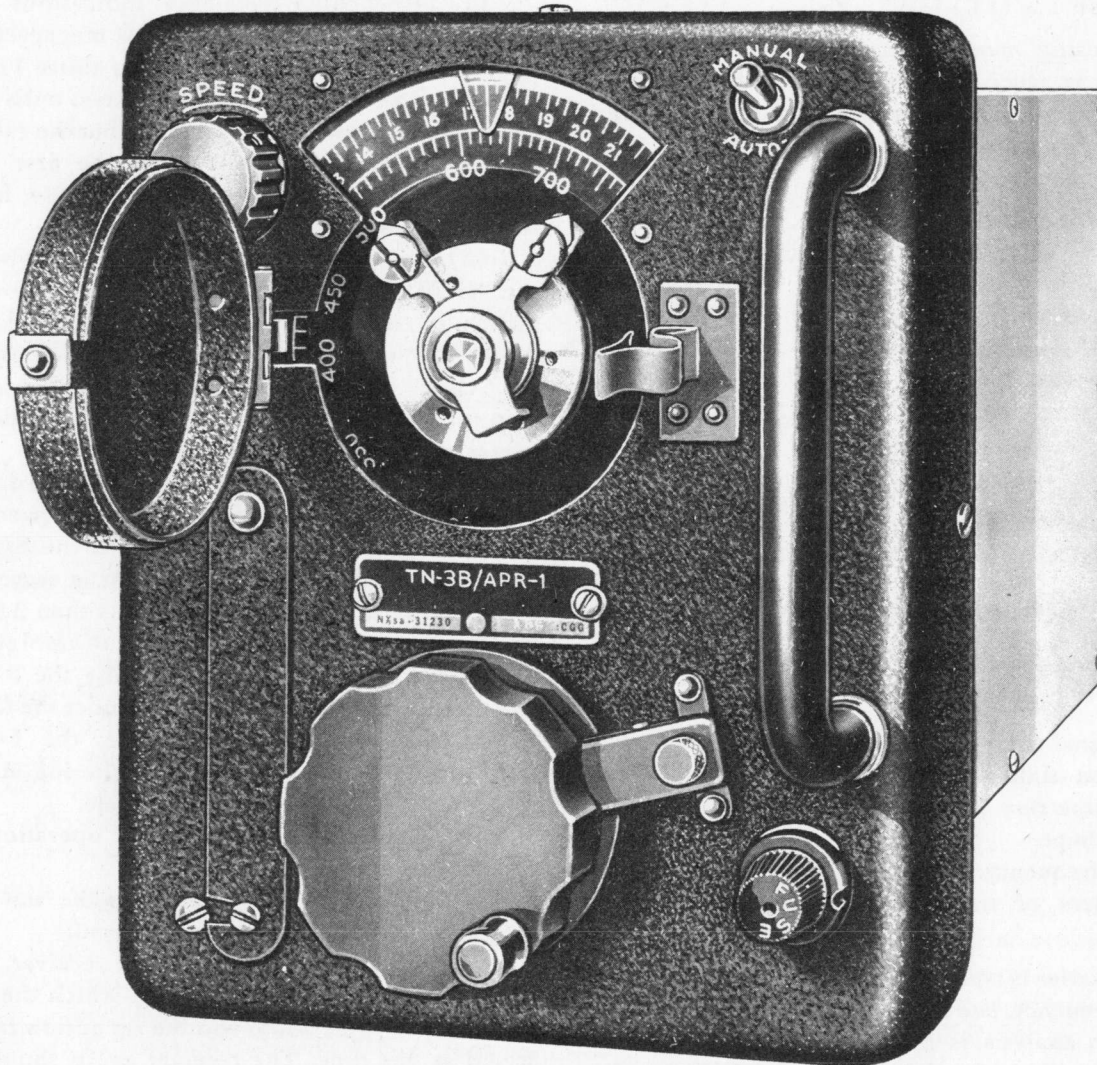

Figure 3-2. Sector Sweep Tuner, Front Panel Open.



that mere agreement between the original frequency found by step (b) and the first null observed by step (c) does not prove that the receiver is tuned to the frequency of the incoming signal unless this frequency is known to be less than 310 mc.

(e) Look for the image. Tune the receiver 60 megacycles *below* the frequency found by step (d), if the TN-1/APR-1 or TN-2/APR-1 Tuning Units are being used, or 60 megacycles *above* this frequency if the TN-3/APR-1 Tuning Unit is being used.

**NOTE:**

*It may be necessary to change tuners in order to complete step (e).*

(f) Discovery of the image response exactly 60 cycles from the frequency found by step (d) will confirm the carrier frequency indicated by step (c). Of course the pulse width and pulse repetition rate found by step (d) must agree with those of the image found by step (e) and the original response logged in step (b).

(g) The receiver may not be perfectly shielded, thus direct pick-up from equipment in the vicinity of the receiver is possible and should be suspected if a sharp null cannot be found in the frequency range from 80 to 310 megacycles. This may readily be checked by disconnecting the antenna cable.

**b. WAVE TRAP F-20/UPR. (Fig. 3-3.)**

(1) The switch on the F-20/UPR *must* be kept in the "OUT" position until a signal is received. When it is desired to measure the carrier frequency of a signal, the switch *must* be in the "IN" position.

(2) Move the tuning slider downward from the high frequency end of the stub. If no null is encountered before reaching 700 mc. calibration point, the signal frequency is *below* 600 mc. and may be read directly on the fixed scale. Fig. 000 shows the reading of a signal on 450 mc.

(3) If a null *is* encountered *above* the 700 mc. calibration, the frequency is *above* 700 mc. and must be measured on the sliding scale as follows:

(a) Move the tuning slider downward from the top end of the stub until a null is found.

(b) Set the zero references on the sliding scale opposite the index on the sliding slider.

(c) Move the tuning slider downward until the next null is found.

(d) Read the frequency on the sliding scale directly opposite the tuning slider index. Fig. 3-3 shows the reading of a signal of 1,300 mc.

(4) When checking very weak signals on the sliding scale, the "side" of the null should be used, as it is difficult to determine the "bottom" of the null. Establish a convenient reference point on the pulse analyzer, where the signal amplitude just begins to dip. By moving the tuning slider down toward the next null until the same reading on the pulse analyzer is obtained, gives an accurate frequency reading for the weakest signal that can be seen.

(5) A definite null will be observed on the F-20/UPR for any signal within the range of 300 to 3,400 mc., provided that the signal is being received through the antenna. Direct pick-up from equipment in the vicinity of the receiver is occasionally possible, and should immediately be suspected if a sharp null can not be found. This may be checked readily by disconnecting the antenna input cable.

(6) Always start at the high frequency (top) end of the stub, and move the tuning slider downward when measuring the frequency of an unknown signal.

**5. JUNCTION BOX J-116/SPR.**

Junction Box J-116/SPR is used to interconnect the antennae to one or more receivers. The SA-14/SPR-1 or switch SA-44A/APR switch will not operate above 1000 mc. and the Junction Box J-116/SPR *must* be used.

**6. R. F. SWITCH SA-14/SPR-1. (Fig. 6-38).**

The R. F. Switch SA-14/SPR-1 consists of a 12-position switch. Only four of the 12 contacts provided are necessary under normal conditions. The unused portions are provided with caps to exclude water. When Radio Receiving Equipment AN/APR-1 and AN/SPR-1 is using during jamming purposes, one of the unused contacts on the R. F. Switch SA-14/SPR-1 should be fitted with a shorting link to short out the antenna. If this, or some equivalent method is not used, excessive power from nearby jamming transmitters will cause the crystal in the receiver to burn out. Some of the later production series of the R. F. Switch SA-14/SPR-1 are provided with a cap having the shorting bar already connected. When this cap is not provided, the equivalent should be made and the position giving a short antenna condition should be marked so that it can be readily used for the jamming operation.

**CAUTION:**

*Be sure that the switch is set for the proper antenna according to the tuning unit being used. (Fig. 1-3.)*

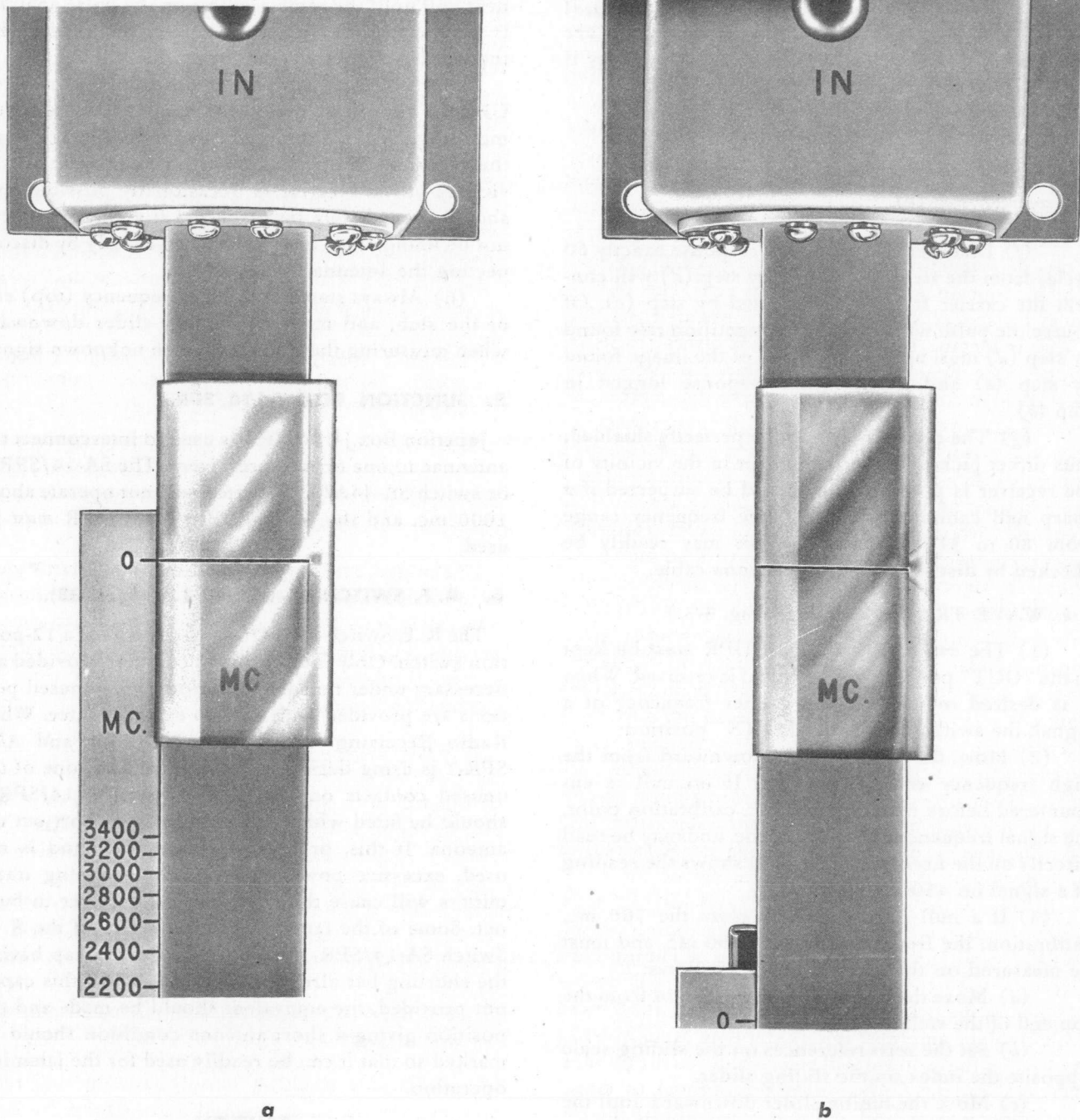

Figure 3-3. Wave Trap F-20/UPR, Operation.

## SECTION IV — MECHANICAL AND ELECTRICAL CHARACTERISTICS

### 1. TUNING UNIT TN-1/APR-1, ELECTRICAL FUNCTION. (Figs. 8-2, 8-3, and 8-4).

This is the lowest frequency tuning unit, covering a range of from 38-95 megacycles in one band. A more or less conventional type of circuit is employed in this unit, composed of an electron coupled oscillator, using a type 9002 tube, and an antenna circuit, in conjunction with another 9002 tube, used as a conventional plate detector. These circuits are tuned by a double capacitor gang (C605 and C606), across which inductance T-601 is connected. The inductances are spaced slightly and are of the air core type. These inductances are made up of several turns of copper wire. Energy from the oscillator is introduced into the grid circuit of the detector, so that mixing, or frequency conversion, can occur. This energy from the local oscillator is combined in the detector (V-602) (mixer) with a signal energy which is built up across the resonant antenna circuit, producing a difference frequency, which is maintained at 30 mc. By electrical means, the frequency of the oscillator is 30 mc (I. F.) above the signal frequency, and (since the 9002 tube, used as a detector in the antenna circuit, is biased so that it presents a non-linear impedance) when combined with another signal of a different frequency, mixing takes place. The plate circuit of the detector contains a circuit which is resonant to the difference between the oscillator and the signal frequencies or 30 mcs., the I. F. signal is brought out through a connector to the input of the I. F. amplifier. Hence, assuming the presence of a signal, the following action will take place: as the tuning unit is varied (tuned) a setting will be found at which the frequency of the local oscillator in the tuning unit will be just 30 mcs. higher than the frequency of the incoming signal (within the limits of the tuning range of Tuning Unit TN-1/APR-1). At this point, an output will be developed in the plate circuit of the detector at 30 mcs., which will be amplified in the Amplifier Strip AM-12/APR-1, and a response will be produced in the phones. The dial on the tuning unit is calibrated in actual signal frequencies, and will therefore indicate the frequency of the incoming signal. There will be no ambiguity in the reading thus obtained, except when the incoming signal is very strong. If this should be the case, there is a possibility that a 30 mc. component will be produced when the frequency of the local oscillator is 30 mcs. below the signal, instead of above

it. A 30 mc. trap filter is included in series with the antenna lead. This filter consists of two parallel resonant circuits tuned to 29.5 and 30.5 mc., respectively. Due to the fact that Tuning Unit TN-1/APR-1 will tune to frequencies as low as 36 mc., which is only 6 mc. higher than the I-F frequency, and due to the fact that the I-F has a broad selectivity characteristic, the filter is necessary to prevent strong signals on or near 30 mc. from coming straight through, from the antenna to the I. F. Amplifier. These signals would, naturally, not be tunable and might prevent reception of other signals. (Fig. 00-00.)

### 2. TUNING UNIT TN-2/APR-1 AND TUNING UNIT TN-3/APR-1, ELECTRICAL FUNCTION. (Figs. 8-5 to 8-10.)

These two tuning units are considered together because, other than the difference in frequency range, they make use of the same basic principles with the following exceptions:

a. Tuning Unit TN-2/APR-1 has its oscillator operating 30 mc. above the antenna or signal frequency, whereas in the TN-3/APR-1 tuning units the second harmonic of the oscillator is employed for mixing and its frequency is always 30 mc. *lower* than the antenna frequency.

b. When the dial of the TN-2/APR-1 reads 150 mc., the local oscillator is operating at 180 mc. If a very strong signal is present at 150 mc., a response will also be found at a dial reading of 90 mc. This is the image frequency and a response occurs because the oscillator is now 30 mc. lower than the incoming signal and the antenna "butterfly" lacks sufficient selectivity to completely reject this undesired response. Other responses can be found if the incoming signal is very strong. These responses are due to the fact that harmonics from the oscillator also mix with the signal to produce the I. F. frequency.

c. In the TN-3/APR-1 tuning unit, the dial reads 500 mc., *e.g.*, when the second harmonic of the oscillator is at 470 mc. and the fundamental oscillator frequency is at 235 mc. Here again an image may be received at 440 mc. and numerous other responses are possible if the incoming signal is strong enough to mix with any harmonic of the oscillator other than the second.

d. When receiving a steady carrier on either the TN-2/APR-1 or TN-3/APR-1 tuning units, the desired signal is that frequency at which the greatest output is found. However, if the signal strength is constantly varying as most radar signals do, a considerable amount of ambiguity arises as to which signal is the proper one. In these cases it is desirable to use Wave Traps F-19/UPR, and F-20/UPR and Filter F-41/SPR-1 to check the receiver and in receiving the actual frequency.

e. The principles employed are quite different from those used in the first tuner, as regards the type of circuit used for tuning purposes. The same general theory of mixing, using a local oscillator coupled to an antenna circuit still holds, however. Both the oscillator and antenna circuits are unique in that the ordinary coil and condenser combinations are absent. These circuit elements are replaced by a so-called "butterfly" unit, which is really a derivation from a split-stator condenser. It is well known that all condensers, or capacitors, have associated with them some inductance. This applies both to fixed and variable capacitors, although more specifically to the variable variety. This inductance does not ordinarily enter into the picture at the lower frequencies. However, in the frequency range covered by Tuning Unit TN-2/APR-1 (from 76 to 300 mcs.) and Tuning Unit TN-3/APR-1 (300 to 1000 mcs.) this residual inductance would begin to limit the frequency range which could be covered. In the "butterfly" type of circuit, advantage is taken of this inherent inductance, making it a part of the actual circuit. The two "wings" of the "butterfly" capacitor represent the variable capacitor part of the circuit (rotor), while the inductance is formed as a part of the construction of the stator.

Incoming radio-frequency signals are introduced into the antenna "butterfly" (LC-502) through a concentric line which is tapped onto the "butterfly" at a point where optimum coupling exists. At resonance, this signal voltage is built up in the same manner as in conventional circuits, and is applied to a type 955 tube (V502) connected as a diode in Tuning Unit TN-2/APR-1, or to an IN-21 crystal, in Tuning Unit TN-3/APR-1, used as mixers, as in Tuning Unit TN-1/APR-1. The crystal is used because the input capacity of a tube is excessive at the frequencies involved. Type 955 tubes are used as local oscillators, one in each of the tuning units, connected into "butterfly" circuits, which are inductively coupled to the antenna "butterflies." This coupling is accomplished by the physical location of the two "butterfly" circuits with respect to each other, and is fixed. Mixing occurs, as discussed in Tuning Unit TN-1/APR-1, and the

resultant output at 30 mcs., is developed across a resonant circuit. The output from this circuit is fed into the Amplifier Strip AM-12/APR-1.

It should be noted that the same precautions as to possible ambiguity of dial readings in the presence of dial readings in the presence of strong signals apply in the operation of these two units. At the higher frequencies, greater care will be required in tuning because the tuning becomes more critical. If the oscillator tube in either of these tuners is replaced the calibration will be disturbed at the high frequency end of the band. Changes of as much as 30 mcs. may be produced. For this reason, the absolute frequency calibration should be checked against a master signal generator, and a chart showing this error made up. The chart should be attached to the particular tuner for reference use. This note also applies to Tuning Unit TN-4A/APR-1, which is discussed in Section IV, paragraph 3.

### 3. TUNING UNIT TN-4A/APR-1, ELECTRICAL FUNCTIONS. (Fig. 8-11).

The frequency range of this tuner is from 1000 to 3400 mcs., and requires a somewhat modified technique to operate. "Butterfly" circuits are still employed, although these become quite small, for the antenna circuit. The local oscillator uses a WE-703A tube, and oscillates only up to 1000 mcs. The second and third harmonics of this oscillator are employed for frequencies above 1000 mcs. Since this tube requires accurate adjustment of the filament voltage to sustain oscillation at the higher frequencies, a series resistor is provided for this control. As a means of checking the condition of oscillation, a type 6E5 tuning eye tube is incorporated. This eye is closed when the oscillator tube is oscillating, and open when it is not. The filament is adjusted through a hole provided in the false front panel of the tuner until the condition of oscillation begins. This adjustment is performed at the higher frequency end of the band, the dial being rotated until the hole is clear to the series resistor, and so that the eye is visible through the hole immediately below the main dial.

The local oscillator energy is coupled into the antenna "butterfly" inductively, as in the other tuners, but no effort is made to track this antenna circuit, mechanically or electrically, to the oscillator circuit. The operation of tuning is accomplished by means of two separate dials, in a manner similar to the old broadcast tuners. A linkage is provided so that the antenna is carried along during the tuning operation to some degree, to facilitate the tuning procedure, but careful adjustment is required to assure that maximum sensitivity is realized. Generally, the antenna control

is varied back and forth as the oscillator control is operated, until a signal is located, after which the correct position for this control is easily ascertained by the loudness of the received signal.

Mixing takes place in an IN-21 crystal connected across the antenna "butterfly" circuit. The output from this crystal, representing the difference frequency between the received signal and the oscillator (30 mcs.) is built up across a resonant circuit as in the other tuning units, and is fed into the Amplifier Strip AM-12/APR-1.

#### 4. AMPLIFIER STRIP AM-12/APR-1, ELECTRICAL FUNCTION. (Figs. 8-12 and 8-13).

After the signal is introduced into the I. F. strip, amplification at 30 mcs. takes place in five practically identical circuits V101, V102, V103, V104 and V105. The signal is built up approximately 90 DB in these circuits, and is then applied to a detector circuit, V106. After rectification (detection) the demodulated output is coupled into a combined audio amplifier and cathode follower stage, V107. The plate circuit of this stage incorporates an output transformer which matches the tube to a load of 600 ohms, nominally, with a tap provided on the transformer to match an output load impedance of 8000 ohms. The cathode of V107 is connected through a concentric line for use with the Pulse Analyzer Equipment AN/(A)PA-6. An impedance of 50 ohms matches the tube, on this line, but a high impedance, such as would be presented by a cathode ray tube, can be placed across this line. Attempting to shunt an impedance of less than 50 ohms across the video circuit will upset the performance of the circuit.

One-half of the 6H6 detector, V106, is used for AVC. A capacitor feeds I. F. energy from the plate of the last I. F. amplifier, V105, into the plate of the 6H6 diode, V106. The load resistor (R-136) of this diode is connected to the variable tap on the gain control potentiometer R-301, where a negative voltage exists. As a signal appears in the I. F. Amplifier, a negative voltage is developed by the AVC diode. This voltage is fed back into the grid circuits of V101, V102, V103, and V104 and the gain of these stages is reduced, providing automatic gain control. The stronger the signal becomes, the greater voltage developed, hence the more the overall gain is reduced. At the same time, and irrespective of the strength of the signal, the gain can be controlled manually by controlling the negative voltage in the AVC circuit by means of the manual gain control. The manual gain control on the Radio Receiver Equipment AN/SPR-1 is provided with an arbitrary scale numbered from 0 to 10, so that relative strength comparisons of the strength of various signals

can be made. The automatic gain control system is inoperative when the AVC off switch is in off position, which increases the delay voltage applied to the cathode of the AVC diode to a value greater than that which any signal can overcome. A small delay voltage is allowed to remain when the AVC circuit is in operation (*i.e.*, AVC switch in "AVC" position). This voltage amounts to approximately 4 volts. Referred to the signal level at the input to the I. F. system, this means that no automatic gain control will take place until the signal has a value of about 200 microvolts. This is so that the gain is not reduced for weak signals.

A 1000 cycle oscillator, V108 (heterotone), is incorporated in the I. F. strip. When this oscillator is actuated by S302 (by the HET on-off switch on the panel), 1000 cycle energy is applied to the grid of the last I. F. amplifier, V105. This tube does not have AVC applied to it, the grid return being arranged for coupling to the V108 oscillator. Grid modulation takes place when the HET oscillator is on, so that an unmodulated CW signal, otherwise practically inaudible, is modulated at 1000 cycles, thus making the signal audible. This grid modulation at 1000 cycles per second as used in the Radio Receiving Equipment AN/APR-1 and AN/SPR-1 is almost independent of any frequency fluctuation of the signal being modulated.

#### NOTE:

*A metal plate on which is shown the resistor-capacitor locations and symbols is mounted on the tuner housing. This chart is to be used for service reference and takes the place of marking on the components or chassis.*

#### 5. RECTIFIER UNIT PP-10/APR-1 ELECTRICAL FUNCTION. (Figs. 8-12 and 8-13).

Either 80 or 115 volts, single phase, power having any frequency from 60 to 2600 cycles can be used with Rectifier Unit PP-10/APR-1. This unit contains a transformer, which has tapped primary for operation at either 80 to 115 volts (set up for 115 volts at the factory) and five secondaries. No. 1, 6.3 volts A.C. at 5 amps. for the heaters of the tubes in the I. F. strip AM-12/APR-1, and in the tuning units. No. 2, and No. 3 two 5 volt A. C. windings at 3 amps. for the two 5Y3GT rectifiers, No. 4 and No. 5 are high voltage windings, delivering 115 volts and 250 volts D.C. after rectification, at 115 and 55 milliamperes, respectively. The 115 volt D.C. output passes through a single choke and condenser filter, while the 250 volt output passes through a double choke and condenser combination. Choke input is used in both cases, to obtain the best possible regulation. A bleeder resistor R201 is provided on the 250 volt output, but none is

used on the 115 volt output. This is because the 250 volt supply is frequently unloaded, when the tuners are removed, which would allow the voltage to rise excessively, and would be dangerous to personnel since this voltage would remain even after the primary power was removed. The 115 volt supply is always loaded and no bleeder is needed, therefore.

**6. TUNING UNIT TN-1/APR-1, MECHANICAL FUNCTION. (Figs. 6-1 to 6-5).**

As indicated in the discussion of the electrical theory of this tuner, the mechanical design is more or less conventional. A two gang variable capacitor is employed. The first section of this gang is used for tuning the oscillator, the second for the antenna circuit. Tracking of the two circuits is accomplished by electrical means. The dial system is made up of a group of spur gears which are spring loaded and split, to reduce back-lash. The tuner is operated by rotation of the large knob, which is the only control on the tuner unit. A locking device, which consists of a clamp, acting on a disc attached to a control knob, is provided so that the dial can be locked against vibration, if necessary. If the unit is to be tuned more or less continuously, this clamp should be left unlocked, by loosening the knurled clamp adjustment counter-clockwise, so as to open the jaws of the clamp and allow the disc to rotate freely. The dial, visible through a transparent window, is calibrated directly in megacycles, and indicates the frequency of the signal.

The tuning unit is provided with a handle, and plugs into the Chassis Base MX-24/APR-1 on guide rails, which are provided with circular springs which serve to ground the tuner, as well as to cushion it. The rear of the tuner has plugs for power and radio frequency connections, which mate with corresponding connectors in the rear of the tuner housing of the Chassis Base MX-24/APR-1 (Fig. 00-00). The tuner unit should never be forced in place by slamming it in rapidly, but should be inserted carefully, with steady pressure. A severe jar could cause damage, which would never occur in ordinary service after the tuner is in place, because the equipment is shock mounted.

A fastener is provided on the lower right hand side of the Mounting Base MT-141/APR-1, exactly like the one on the left hand side, except that it is longer and heavier. This fastener must be loosened before the tuning unit can be removed. When a new tuning unit is put in place, this fastener must be tightened, and locked in place by means of the back-up nut provided for this purpose. (Fig. 00-00.)

**7. TUNING UNITS TN-2/APR-1 AND TN-3/APR-1, MECHANICAL FUNCTIONS. (Figs. 6-6 to 6-21).**

These two tuners, mechanically, are very nearly identical. They differ from Tuning Unit TN-1/APR-1 in that a mechanical method is used to track the oscillator and antenna circuits. "Butterfly" type circuits are used instead of the more orthodox variable capacitors, as already mentioned, because of the high frequencies involved. (Fig. 00-00.)

The tuning action is accomplished by means of the tuning knob on the front panel of the tuner, as in Tuning Unit TN-1/APR-1. The motion of this knob is transmitted through a system of split gears to a cam linkage system located on the underside of the tuner casting. The motion is transferred to the oscillator and antenna butterfly units by these same cams. Since the oscillator and antenna butterflies do not follow the same law of angular rotation versus frequency (because the oscillator operates on a submultiple of the antenna frequency) compensation must be effected if the two circuits are to track together over the bank. This compensation is effected in the design of the cam system controlling the motion of the two butterflies. Further modification of the motion or travel of the antenna butterfly cam is effected by a series of screws which pass through a block of metal on the front panel of the tuner. These screws are adjustable and accessible through a slot in the false front panel. They govern the travel of a roller which is linked to the cam operating the antenna butterfly. Small changes in the motion of the main cam are produced by this roller, so that additional adjustment of the trackage can be effected, to compensate for difference in antenna characteristics. The use and adjustment of these screws is discussed in Section V, paragraph 6. All the screws in this adjustment system are friction locked.

Excessive play in the cam system is taken up by means of spring loading. The springs are so placed that tension is brought to bear on the worm drive which actuates the oscillator butterfly, so that lost motion in this drive is also taken up. There are no adjustments other than are provided by the screws described above, which need to be made on the tuning unit, in ordinary circumstances.

**8. TUNING UNIT TN-4A/APR-1 MECHANICAL FUNCTION.**

This unit, while employing butterflies in its design, differs from the last two tuners in that no effort is made to track the two circuits together either electrically or mechanically. The oscillator and antenna circuits are controlled by two individual control knobs. The large knob, which is the same as the main tuning control knob used on the lower frequency tuners, con-

controls the oscillator circuit, while the smaller knob tunes the antenna butterfly. This latter control is linked to the main tuning knob over a portion of the tuning range. The effect is to drag the antenna control over a part of the frequency range of the unit, so that possibility of error in setting up the unit to a given frequency is greatly minimized. No method of adjustment is provided on this unit, because of this interlinkage.

**9. SECTOR SWEEP, ELECTRIC AND MECHANICAL FUNCTIONS. (Figs. 6-22 to 6-24).**

A small 28 volt permanent magnet field D-C motor is geared through a worm drive system into the gear train of the tuning unit. A reversing switch operated by two small wings or flaps, attached to the dial, governs the direction of travel. The position of the

flaps are set by means of two pointers on the dial, as explained in Section III, paragraph 1 b (2) (b). The speed of the action can be controlled by the SPEED control on the front panel. Manual tuning can be used at any time, but the switch on the front panel must be in the MANUAL position, so as to stop the motor and de-energize the magnetic clutch which couples the motor drive into the normal gear train. The motor is filtered electrically and is completely shielded. It is mounted on rubber and coupled to the worm shaft through a rubber coupling, providing complete electrical and mechanical isolation. The hash chokes and capacitors form a network to prevent undesired frequencies from entering the 28 volt line and coming back into the receiver. The motor chokes, and capacitors are enclosed in a shield box, thus keeping electrical and mechanical noise at minimum. The entire assembly is rubber shock mounted.

# FAILURE REPORTS

A FAILURE REPORT must be filled out for the failure of any part of the equipment whether caused by defective or worn parts, improper operation, or external influences. It should be made on Failure Report, form NBS-383, which has been designed to simplify this requirement. The card must be filled out and forwarded to BUSHIPS in the franked envelope which is provided. Full instructions are to be found on each card.

Use great care in filling the card out to make certain it carries adequate information. For example, under "Circuit Symbol" use the proper circuit identification taken from the schematic drawings, such as T-803, in the case of a transformer, or R-207, for a resistor. Do not substitute brevity for clarity. Use the back of the card to completely describe the cause

of failure and attach an extra piece of paper if necessary.

The purpose of this report is to inform BUSHIPS of the cause and rate of failures. The information is used by the Bureau in the design of future equipment and in the maintenance of adequate supplies to keep the present equipment going. The cards you send in, together with those from hundreds of other ships, furnish a store of information permitting the Bureau to keep in touch with the performance of the equipment of your ship and all other ships of the Navy.

This report is not a requisition. You must request the replacement of parts through your Officer-in-Charge in the usual manner.

Make certain you have a supply of Failure Report cards and envelopes on board. They may be obtained from any Electronics Officer.

NAVY DEPARTMENT  
BUREAU OF SHIPS  
WASHINGTON, D. C.  
OFFICIAL BUSINESS

PENALTY FOR PRIVATE USE TO AVOID  
PAYMENT OF POSTAGE \$200.

NAVY DEPARTMENT  
BUREAU OF SHIPS  
ELECTRONICS DIVISION, CODE 960  
WASHINGTON 25, D. C.

**FAILURE REPORT—ELECTRONIC EQUIPMENT**

NOTICE—Read notes on reverse side. Add: Serial Number and Name of Station

DATE: 18 Oct. 1946

NAME OF PERSON MAKING REPORT: John Doe

ELECTRONIC EQUIPMENT INVOLVED: Model 55 55 AGV Indicator Console

CHECK ONE:  RADIO  RADAR  SONAR  OTHER

EQUIPMENT SERIAL NO.: 2097

MANUFACTURER: Western Electric Co.

CONTRACT NO.: 7XSR 51503

DATE REPORT RECEIVED: 2 Nov. 1945

ITEM WHICH FAILED: 6 SNT-6T

THIS SIDE FOR COMPONENTS: THIS SIDE FOR ASSEMBLY

TYPE OF FAILURE: STORAGE  OVERHEATING  OTHER (SPECIFY): Shorted plate and grid. This caused

DATE OF OCCURRENCE: 1608 18-OCT-1945

TIME OF FAILURE: 2

CIRCUIT SYMBOL: 105

REMARKS (Continued): Failure of sweep on time multivibrator in PPI Sweep and Video panel, resulting in loss of sweep on PPI Scope.

PREVIOUS INSTRUCTIONS PERTAINING TO THE PREPARATION AND SUBMISSION OF THIS REPORT: Refer to previous versions of Navy Form NBS-383 and 381. Previous instructions pertaining to the preparation and submission of this report are being observed to conform to current procedures.

REPLACEMENTS: All replacement of parts shall be ordered from your Tender, Supply Depot, Supply Officer, or Radio Material Officer. (This procedure will permit failure analysis by IB in the case of a failure.)

REMARKS: All replacement of parts shall be ordered from your Tender, Supply Depot, Supply Officer, or Radio Material Officer. (This procedure will permit failure analysis by IB in the case of a failure.)

Sample Failure Report Cards Properly Filled In



## SECTION V — MAINTENANCE

### WARNING:

*Only trained repair personnel in a depot furnished with the special items of equipment necessary for repair and alignment are authorized to make adjustments on this equipment. Many sets turned in for repair are inoperative only because of unauthorized tampering. Don't deprive a combat unit of radio equipment. Equipment turned in for repairs means that some unit is without a communication system.*

### 1. TO REMOVE RADIO RECEIVING EQUIPMENT AN/APR-1 and AN/SPR-1 FROM ITS MOUNTING BASE AS FOLLOWS:

To remove Radio Receiving Equipment AN/APR-1 and AN/SPR-1 from its mounting base as follows:

- a. Loosen the right hand knurled nut on the mounting base and disengage it from the tuning unit.
- b. Remove tuning unit from receiver.
- c. Loosen the left hand knurled nut, and disengage it from bracket (A311) of front panel.
- d. Slide the receiver off its mounting base.
- e. Turn dust cover retainer on back of dust cover 90 degrees to the left. (Counter-clockwise.)
- f. Slide receiver out of dust cover.

### 2. REMOVAL OF AMPLIFIER STRIP AM-12/APR-1. (Figs. 6-45 and 8-12).

#### NOTE:

*Before disconnecting or unsoldering leads, mark them in a suitable manner in order to be able to reassemble correctly to their respective terminals.*

- a. Unsolder all leads on the terminal board next to the front panel, numbered 1-6, and terminal board at the lower end of the strip numbered 1 and 2.
- b. Unsolder the short coaxial cable (E310) from terminal number 5 of tube socket V107.
- c. Unsolder the medium coaxial cable (E309) from the terminal strip to which it is connected.
- d. Unsolder resistor R-143 from terminal strip on support of L101.
- e. Unsolder soldering lug of receptacle X303 from soldering lug on coil support of L101.
- f. Remove the 17 screws along the outer edges of the strip.
- g. Lift Amplifier Strip AM-12/APR-1 off Chassis Base MX-24/APR-1.

### 3. REMOVAL OF RECTIFIER PP-10/APR-1. (Figs. 6-45 and 8-12).

- a. Unsolder all leads connected to the terminal strip, numbered 1-7.
- b. Remove the 18 screws fastening Rectifier PP-10/APR-1 to Chassis Base MX-24/APR-1.

### 4. ALIGNMENT PROCEDURE FOR AMPLIFIER STRIP AM-12/APR-1. (Fig. 6-45 and 8-13).

The Amplifier Strip AM-12/APR-1, for the Radio Receiving Equipment AN/APR-1 and AN/SPR-1 is aligned and tested at the factory at 30 megacycles. If for any reason it should become necessary to re-align it, such as would be the case if an I. F. coil or other major component were replaced, the following procedure should be used.

- a. Set up the receiver on a bench, panel upwards, without the shock mount or dust cover, and without a tuner. Section V, paragraph 1.
- b. Connect to a suitable power source (60-2600 cycles, single phase; if 80 volts, be sure the tap on the power transformer is changed to accommodate this voltage. The chassis bears a stamp indicating the proper terminal for this line voltage condition).
- c. Turn receiver on, adjust gain control for maximum, turn AVC switch and Heterotone oscillator switch off. Plug in a 600 ohm headset for checking audio output.
- d. Connect a signal generator (such as Ferris Model 18C) capable of generating a 30 megacycle signal to the I. F. input plug X303. The generator should be capable of attenuation down to a signal level of about 100 micro-volts with reasonable accuracy. The frequency must be known within .25 mcs. Adjust the signal input from the generator so that a definite reading appears on the tuning meter, of the order of 1/2 scale. Using the tuning wrench supplied in clips on the side of the tuner housing, adjust each I. F. coil trimmer beginning with L101 and continuing with L102 up to diode, L105 for maximum deflection of the tuning meter. Keep reducing the level from the generator as the tuning meter reading rises too high. When completely aligned, the tuning meter should show a reading of about 75 microamperes, for an input of 100 microvolts from the generator. This corresponds to a gain of 10,000 for the amplifier.

e. By modulating the signal (I. F.) and listening in the phones, the receiver can be checked for audio operation. The action of the heterotone oscillator can also be checked at the same time, by feeding an unmodulated carrier of about 100 microvolts level into the I. F. Turning on the heterotone oscillator should result in a clearly audible signal modulated by the action of the heterotone oscillator at a frequency of about 1,000 cycles.

f. The action of the AVC can be checked by turning the switch on and off while feeding into the I. F. a strong signal from the generator, modulated at 400 or 1,000 cycles. Use a signal level of approximately 100,000 microvolts. and set the manual gain control of the receiver at maximum.

If the AVC is operating properly, it will be found that the signal will be strong and clear in the phones, while if the AVC is turned off the signal will sound flat and mushy, or will become almost inaudible. Bear in mind that the AVC will not operate on a pulsed signal, because the average energy content of such a signal is so low that it cannot develop a voltage in the AVC system sufficient to operate it. The AVC circuit will only operate in the presence of non-pulsed carriers. For this reason, care must be exercised to see that overloading does not occur in the receiver when receiving pulsed signals. In general, the gain control (manual) should always be turned down after a signal is picked up to as low a level as will still permit analysis.

#### 5. ALIGNMENT OF TUNING UNITS TN-1/APR-1 AND TUNING UNIT TN-1B/APR-1. (Fig. 6-1).

##### a. TRACKING.

(1) Couple a signal generator, preferably one having a low output impedance, through a carbon 50 ohm  $\pm 20\%$  resistance to the antenna input terminal on the chassis with the TN-1 or TN-1B tuning head plugged in and the equipment running. Tune the head to the high frequency end of the band, to 90 mcs., and the generator likewise. A signal should be heard with an input of the order of 10 to 50 microvolts. The generator should be accurately calibrated as to frequency, and should be set to exactly 90 mcs. Set the tuning head to 90 mcs. on the dial, and adjust first the oscillator trimmer C603/C1006 (TN-1 and TN-1B, respectively) to produce a maximum output. Use the tuning meter on the chassis to indicate maximum. Then adjust the antenna trimmer C604/C1006 for maximum output. Reset the generator to 40 mcs. and tune the TN-1 to 40 on the dial. Adjust C607/C1009 for maximum output. The entire procedure should always be repeated several times if any noticeable change in the setting of C607/C1009 is noted.

(2) Next adjust L601/L1006 for maximum, with signal generator set to 30 mc. (increase generator output for suitable output indication).

(3) With generator still set to give a suitable output reading at about 30 mcs., vary the frequency above and below this frequency, from about 29 to 31 mcs. At the same time this is done, L1004 and L1005 (in sector sweep models only) should be adjusted for minimum response. It is urged that the adjustment of these coils be done *only if the filter or I. F. rejection trap has been replaced*. The adjustment is somewhat difficult to make without special equipment, while the nature of the design is such that adjustment will never normally be necessary.

(4) Normal output (50 mw.) should be obtained with inputs of the order of 10 to 50 microvolts.

(5) Inductance adjustments to either oscillator or antenna circuits (T601/T1001) should rarely be needed, and it is not recommended that such adjustment be attempted in the field. Adjustment is accomplished by squeezing the turns closer together to increase the inductance or prying them further apart to decrease. The adjustment is not extremely critical, but must be done carefully.

#### 6. ALIGNMENT OF TUNING UNITS TN-2/APR-1 AND TN-3/APR-1.

##### a. CAM ADJUSTMENT.

The nine screws that are exposed when the cover over the panel port is swung to one side, control the adjustable cam. The cam consists of a laminated pile of phosphor bronze strips, the contour of which is determined by the screw settings. A roller riding on this cam transmits the motion from the rotor shaft of the oscillator "butterfly" circuit to the rotor shaft of the antenna "butterfly" circuit. The indicator to the left of the row of adjusting screws shows the location of the roller on the cam for any dial setting.

##### TO ADJUST THE CAM FOR MINOR VARIATIONS:

(1) A test oscillator of the same frequency range as the tuning unit should be very loosely coupled to the receiver through the antenna system for which the receiver is to be aligned.

(2) Tune the receiver to the test oscillator frequency.

(3) Adjust the test oscillator frequency until the receiver tunes with the indicator directly opposite one of the adjusting screws.

(4) Turn adjusting screw for maximum output signal.

(5) Repeat for each of the nine adjusting screws.

(6) Run over complete set a second time to check adjustment.

### TO ADJUST THE CAM FOR MAJOR VARIATIONS:

If a major change in adjustment is necessary, the foregoing procedure may become difficult. When a drastic change in input system is made, for instance, time will usually be saved by the following procedure:

- (1) Remove the left-hand cover from the tuning unit casting to show cam and linkage system described at the beginning of this paragraph.
- (2) Back the screws out until the cam roller no longer moves toward the panel.
- (3) Replace the tuning unit cover and reinsert unit in receiver.
- (4) Starting at one of the adjusting screws in the middle of the tuning range, repeat the procedure described for minor adjustment.

#### b. CALIBRATION.

The tuning units are calibrated at the factory and recorded on a Dial Calibration Chart which is supplied with each tuner.

If the oscillator tube Type 955, is replaced, the dial calibration will change, necessitating a recalibration of the tuner. A spare chart is supplied for recording the new calibration.

Use a General Radio Heterodyne Frequency Meter Type 720-A, or equivalent, as source of standard signals. Calibrate the dial by beating the oscillator in the tuner to the desired harmonic or fundamental of the frequency meter. Mark the 100 megacycle point on the spare calibration chart and draw a curve to determine the intermediate points.

c. Tuning Unit TN-3/APR-1, has a built-in filter to prevent interference from nearby radars having a frequency of approximately 200 mc. The filter has been peaked for 200 mc. at the factory. If the interfering signal is somewhat different from 200 mc., the filter should be adjusted for maximum attenuation to the interfering signal.

To make this adjustment, the receiver should be removed from the dust cover and turned up with the bottom in full view. This will expose two holes on the tuning unit containing the filter tuning slugs. The receiver should be turned on and the gain control should be rotated to maximum. The interfering radar should be turned on. Then the two slugs should be adjusted for minimum interference. If the frequency of the interfering signal is changed, the above operation will have to be repeated.

### 7. ALIGNMENT OF TUNING UNIT TN-4A/APR-1. (Fig. 6-41).

Remove the small snap cover over the screwdriver adjustment port. Turn OSCILLATOR FREQUENCY

dial to about 600 mc. to line up the small hole in the dial with the screwdriver adjustment port. Turn the screwdriver adjustment counter-clockwise (left) as far as possible. Turn screwdriver adjustment clockwise (right) until electron-ray-tube pattern closes. Turn oscillator frequency over entire tuning range and check that electron-ray-tube pattern remains closed. If this adjustment is made with the aircraft on the ground, it should be repeated when in the air. The screwdriver adjustment should not be turned further clockwise than necessary to secure proper oscillation in order to conserve tube life.

#### NOTE:

*The antenna dial is calibrated on the Tuning Unit TN-4A/APR-1.*

a. Turn the OSCILLATOR FREQUENCY dial by means of the large knob immediately below it until a signal is detected, either audibly or by meter deflection.

b. Tune antenna by means of ANTENNA TUNING knob until meter deflection is at maximum.

c. Vary the oscillator frequency within a range of  $\pm 60$  mc. from the original setting until a new response is obtained.

One of the two responses occurs when the oscillator frequency (or a harmonic of it) is lower than the signal frequency by 30 mc. (the intermediate frequency); the other response occurs when the oscillator frequency (or its harmonic) is higher than the signal frequency by 30 mc. The two beating signals from the local oscillator are therefore separated by 60 mc.

Since, however, the beating signals are generally at harmonics of the local oscillator frequency, the frequency separation on the OSCILLATOR FREQUENCY dial will not be 60 mc., but will depend upon the order of the harmonic, as follows:

Harmonic	Frequency Separation on Oscillator Frequency Dial
Fundamental.....	60 mc.
2nd.....	30 mc.
3rd.....	20 mc.
4th.....	15 mc.
5th.....	12 mc.
6th.....	10 mc.
7th.....	8.6 mc.
8th.....	7.5 mc.

The most sensitive condition occurs when the second harmonic of the oscillator frequency is used to beat with the incoming signal in the range from 950 to 2000 mc., the third harmonic from 2000 to 3000 mc., and the fourth harmonic above 3000 mc.

d. Find the frequency separation from the two settings of the OSCILLATOR FREQUENCY dial. Determine the order of the harmonic from the table above. To find the signal frequency multiply the average of the two frequency settings by the order of the harmonic.

$$f_s = \frac{f_1 + f_2}{2} - \frac{60}{f_2 - f_1} = 30 \frac{f_1 + f_2}{f_2 - f_1} \quad (1)$$

Where  $f_s$  is the signal frequency,  $f_1$  is the lower of the two frequency settings and  $f_2$  the higher.

e. If it is desired to obtain maximum sensitivity to the incoming signal, tune Tuning Unit TN-4A/APR-1 to a frequency 15 mc. below or 15 mc. above half the signal frequency, in the range between 950 and 2000 mc.; to a frequency 10 mc. below or 10 mc. above one-third of the signal frequency, in the range between 2000 and 3000 mc.; and to a frequency 7.5 mc. below or 7.5 mc. above one-quarter of the signal frequency in the range above 3000 mc.

As a typical example, suppose the two first-observed frequencies,  $f_1$  and  $f_2$ , are 549 and 561 mc. From the harmonic table, the difference of 12 mc. means that the 5th harmonic of the local oscillator is beating with the incoming signal. The average frequency is 555 mc., so the signal frequency must be  $5 \times 555 = 2775$  mc. If Equation (1) is used directly:

$$f_s = 30 \times \frac{1110}{12} = 2775 \text{ mc. (10.8 cm.)}$$

For maximum sensitivity the oscillator frequency should be set so that the third harmonic of the local oscillator beats with the incoming signal. This will occur at an OSCILLATOR FREQUENCY dial setting of:

$$\frac{2775}{3} \pm 10 = 915 \text{ mc. or } 935 \text{ mc.}$$

Response to the 2775 mc. signal may be found at various harmonics, as follows:

Harmonic	$f_1$	$f_2$	$f_2 - f_1$
3rd	915 mc.	935 mc.	20 mc.
4th	686 mc.	701 mc.	15 mc.
5th	549 mc.	561 mc.	12 mc.

As a further example, suppose the two first-observed frequencies,  $f_1$  and  $f_2$ , are 1089 and 1109 mc. From the harmonic table the difference of 20 mc. means that the 3rd harmonic of the local oscillator is beating with the incoming signal. The average frequency is 1099 mc., so the signal frequency must be

$$3 \times 1099 = 3297 \text{ mc.}$$

If Equation (1) is used directly:

$$f_s = 30 \times \frac{2198}{20} = 3297 \text{ mc. (9.1 cm.)}$$

For maximum sensitivity the receiver should be set so the 4th harmonic of the local oscillator beats with the incoming signal. This will occur at an OSCILLATOR FREQUENCY dial setting of:

$$\frac{3297}{4} = 7.5 = 817 \text{ mc. or } 832 \text{ mc.}$$

Response to the 3297 mc. signal may be found at various harmonics, as follows:

Harmonic	$f_1$	$f_2$	$f_2 - f_1$
3rd	1089 mc.	1109 mc.	20 mc.
4th	817 mc.	832 mc.	15 mc.
5th	653 mc.	665 mc.	12 mc.
6th	545 mc.	555 mc.	10 mc.

When all that is required is the recording of a signal and its characteristics, one pair of frequency settings will determine the signal frequency. It is often desirable, however, to check at another pair of frequency settings, particularly when the presence of numerous signals make identification of any one uncertain.

## B. TROUBLE SHOOTING.

### a. BASIC CHASSIS.

#### (1) RECEIVER DEAD.

If pilot lamp is also dead, check the fuse. If fuse is good, check the tubes to see if they are operating. The rectifier tubes are visible. In general, if the I.F. tubes are too hot to permit holding the hand on them, they will be normal, if warm, but the hand can be held on them, the B supply is open and only the heaters are operating. Use the voltage chart, Fig. 6-72 and 6-74, to check the source of the trouble, or if the set is completely dead, use the resistance chart, Figs. 6-73 and 6-75, to make a point to point analysis.

#### (2) HETEROTONE OSCILLATOR DEAD.

Interchange or replace the 6AC7 tube. Short the heterotone oscillator cathode to ground. If this causes the oscillator to work, the trouble will be in the switch.

#### (3) AVC INOPERATIVE.

Check switch. Look for shorted bypasses. Follow AVC line to each tube. Look for shorted tube.

#### (4) ERRATIC BEHAVIOR.

Look for the evidence of a loose connection, if the erratic behavior is accompanied by noise. Tap the various components carefully with a screwdriver to localize the trouble.

Move the tubes with the hand (protected by a cloth) if the condition is not accompanied by noise. Watch the tuning meter as this is done. Sometimes the tube will break into a high frequency parasitic oscillation, causing the gain to fluctuate. This condition is the result of the tube structure failing for some cause, or the socket. Make certain the tube hold-down clamps are contacting the tubes through the paint at the base of the tube.

Look for open by-passes, or open ground returns. Check to see that the components are in their original positions by referring to Figs. 6-67 and 6-68. Place a new capacitor, resistor, etc., temporarily in parallel with the suspected defective part.

If the receiver is noisy when jarred, either, replace all the tubes, or replace them one at a time until the noise is eliminated. The last tube or stage from which the tube was removed and which stops the noise is the one to be investigated further.

(5) LOW GAIN.

Replace tubes. If gain is very much reduced, check the plate voltage on each stage. If no meter is available, feel the tube. If only slightly warm, there is no plate voltage. Look for signs of broken coil leads, shorted by-passes, open B+ resistors. Change the tube, if in a particular stage. (Figs. 8-12 and 8-13.)

(6) MANUAL GAIN CONTROL FAILURE.

Measure voltage appearing on terminal No. 3 of the terminal board located near the audio output transformer (nearest the front panel of the receiver). The voltage should vary as the gain control is varied, from zero to about minus 5 or 6. Replace the control. Look for evidence that C-201 in the power supply (PP-10/APR-1) is shorted. Check through resistance chart.

b. TUNING UNIT TN-1/APR-1. (Fig. 6-2.)

(1) DEFECTIVE TUBES—Cause unit to go dead. Replace tubes, but make certain to trim unit at high frequency end of band for maximum accuracy of calibration. Low frequency end will not be disturbed.

(2) DEFECTIVE COMPONENTS, WIRING, ETC.—Can be traced by the usual methods outlined under trouble shootings given under the basic chassis and should be followed for all tuners where applicable.

(3) BREAKAGE OR SERIOUS DAMAGE to component parts necessitating replacement, usually means that a complete realignment is also required. Instructions for alignment of the tuner are given under that heading. Alignment of the I-F rejection trap in the antenna circuit is simple. The trap is composed of two parallel resonant circuits in series with the antenna. One of the circuits is resonated approximately 2 mcs. below the I-F, the other, 2 mcs. above, or at 28 and 32 megacycles. The circuits are not critical, being

resistance loaded to approximate the characteristics of the I-F amplifier.

(4) NOISY.—If the noise only appears when tuning the unit, look for trouble in the variable capacitor, dust, bent plates, etc., will cause noise. Blow unit with air hose, or if none is available, jar it while blowing between plates, if dust is the trouble. If the noise is steady regardless of tuning, it can be caused by a partially open resistor, or a partially shorted by-pass or coupling capacitor. Examining these elements, and also wiring may reveal the trouble. Carefully moving the parts may show up the defective part, or wiring, by completing the breakage. Excessive gathering of dirt, fungi or other foreign material should be cleared away from wherever it is found. Move the tubes in their sockets slightly, to free the contacts.

(5) LOW SENSITIVITY.—Usually caused by a failing tube. May also be the result of some other factor, or a complex mixture of causes. Prodding all available components and wiring may help to localize the trouble. For this purpose a thin, blunt, rod of bakelite is best, in order not to injure any of the components. Checking line voltage, and replacing the suspected tuner with another, of different range, will prove whether the trouble is in the tuner or in the basic chassis. Do not overlook the antenna system as a source of trouble.

(6) ERRATIC BEHAVIOR.—Look for the same source of trouble outlined above. If the nature of the trouble is definitely cyclic, that is occurs at regular intervals, look at once for a tube with a defective heater, or for some other occurrence connected with temperature. Sometimes a resistor, defective, heats up, causing it to heat up and expand, breaking the circuit. As the part cools, it contracts and makes the circuit again.

c. TUNING UNITS TN-2/APR-1 AND TN-3/APR-1.

Since these tuners differ infrequency range, and use of butterfly circuits, from the TN-1, they are discussed under a separate heading. The list given above applies also to these tuners, however.

(1) LOW SENSITIVITY.—Look for tube trouble, or in the TN-3 unit, crystal trouble. The 1N-21 crystals are easily overloaded, causing low sensitivity. The overload occurs chiefly when local radar signals are being picked up, such as the ship radar. The only solution is replacement. It is advisable to handle the crystals carefully, and when inserting a new one in the unit, touch the butterfly lightly with one hand while clipping the crystal in place. This is advisable in order to discharge any static charge present on either the tuning unit or the person. A difference in potential sufficient to damage the crystal can easily exist from

this cause. By the same token caution should be used when holding the crystal never to allow the end opposite that being held to touch any other without exercising the precaution just discussed.

Contacts in the plugs used for connecting the antenna concentric line should always be checked, as well as the antenna itself, as these may be damaged.

(2) CAM ROLLER ACTION ERRATIC.—Sometimes a TN-2 tuner will develop trouble in that the cam roller which rides over the set of 9 tracking screws will begin to stick, especially near the low frequency end of the band. This condition has been corrected in later units, but it can be fixed in earlier units by removing one of the flat springs under the cam roller. This is a rather lengthy job, and should not be done unless necessary.

(3) SPINNER KNOB SLIPS.—A friction clutch is used in all the tuners, consisting of a spring washer on one side of the spinner knob shaft pinion (gear). By loosening the set screws in the collar next to the spring, the tension of the spring can be increased by sliding the collar toward the pinion gear.

(4) RE-CALIBRATION.—In the event re-calibration is necessary, the new calibration figures are to be entered on the extra, blank, calibration chart, working from the linear dial scale, which is supplied along with the original chart, for that purpose. In recognition of the fact that an absolutely accurate initial calibration is of little practical value in the field, because the absolute accuracy is lost the moment a tube is changed, the linear scale and calibration charts are supplied. Hence for maximum accuracy of frequency reading, reference should always be made to this chart. In general the actual difference between the chart readings and the actual dial frequency reading will be found to be negligibly small. For re-calibration purposes, access to a standard frequency source is required. A General Radio Type 720A Heterodyne Frequency Meter is accepted. For this reason, work of this nature is not feasible in the field. The linear dial scale under discussion is the outer ring of figures on all the tuner dials, and is marked off in degrees.

(5) The TN-3 unit incorporates a filter in the antenna circuit whose function is to reduce interference produced by local 200 megacycles radar transmitters. If interference is noted on the TN-3 from nearby radar, an improvement can sometimes be effected by trimming this filter, using the hexagon-end tuning rods supplied on the Basic Chassis. The filter can be trimmed for minimum response to the unwanted signal, if its frequency is in the neighborhood of 200 megacycles, by adjusting the setting of the coil slugs in the filter, accessible through two holes in the side of the tuner casting.

## 9. HASH ELIMINATION FROM TN-(\*)B/APR-1 SECTOR SWEEP TUNERS. (Figs. 6-42, 6-43, and 6-44).

Through use in the field, some early models of Sector Sweep Tuning Units produced on Contract NXsa 43376, have acquired noise or hash. This hash can be approximately 80% removed by shielding and filtering with three RCA "toothpick" mica capacitors, and three No. 4 soldering lugs.

### NOTE:

*These capacitors must be non-inductive and of 240 micro-microfarads capacity.*

a. The following steps will enable the operator to make this change.

- (1) Place the tuner on a bench with the Hold-Down Bracket toward the operator.
- (2) Remove the speed control knob.
- (3) Loosen the setscrews in the spinner knob.
- (4) Remove the four 6-32 binderhead machine screws located on the side of the cover.
- (5) Remove the two 6-32 flathead machine screws located on the underside of the panel holding the handle.
- (6) Remove the one 6-32 binderhead machine screw from the lower left hand corner of the cover.
- (7) Lift off the cover.

### IMPORTANT:

*Before attempting step No. 8, it is very important to mark the position of the dial hub relative to the square shank of the dial drive shaft. (Fig. 6-44 ①.)*

- (8) Remove the screw from between the pointer lugs, and loosen the setscrews in the collar of the dial hub. (Fig. 6-44 ①.)
- (9) Lift off the dial hub completely.
- (10) Remove the 2-56 flathead screw and spacer from the dial pointer. (Fig. 6-44 ②.)
- (11) Rotate the dial pointer so as to clear the dial.
- (12) Lift off the dial completely.
- (13) Remove the seven 4-40 binderhead screws from the silver plated motor shield. (Fig. 6-44 ②.)
- (14) Lift off the motor shield.
- (15) Unsolder the two 650 micro-microfarads capacitors from the bottom side of the motor lug and discard them.
- (16) Remove the two assembly screws from the motor on the opposite corners from the brush tension springs. (Fig. 6-43 ①.)
- (17) Bend two No. 4 lugs, Fig. 6-43 ①, at a right angle at the base under the assembly screws (see step 16) and reassemble at a right angle flush with the motor housing.

(18) Unsolder the brush leads and choke from the present tab. (Fig. 6-43 ②.)

(19) Solder a 240 micro-microfarad "toothpick" capacitor under each bent lug, Fig. 6-43 ③, to the outside of the capacitor case.

(20) Solder the active lead of the capacitor to the motor lug. (Fig. 6-43 ④.)

(21) Connect the brush lead to the capacitor and motor lug. (Fig. 6-43 ④.)

**CAUTION:**

*Make certain that the capacitor is mounted so that no portion projects beyond the motor, as shorts to the motor shield will occur.*

(22) Reassemble the motor to the mounting plate, taking care to insert the shaft of the motor into the rubber coupling from the worm shaft.

(23) Solder the choke leads to the upper motor lug.

(24) Replace the motor cover, making certain all the screws are tightened securely.

(25) Replace the dial.

(26) Reassemble the dial pointer, replacing the 2-56 flathead screw and spacer.

(27) Replace the dial hub with the spacer and screw, and tighten all the screws securely.

**IMPORTANT**

*Be sure the dial hub is replaced in the same position as marked when removed.*

(28) Remove the hexagon nut from the auto manual switch. (Fig. 6-45 ④.)

(29) Insert the spring wiper on the switch shaft and reassemble.

(30) On the lower right hand edge of the panel, Fig. 6-45 ⑤, drill and tap two 4-40 holes  $\frac{7}{8}$ " c-c; the first hole is  $\frac{1}{2}$ " from the bottom and  $\frac{1}{4}$ " in from the right hand edge. The second hole is  $\frac{7}{8}$ " in from the first hole and  $\frac{1}{4}$ " in from the edge.

(31) Mount the spring wiper with a 4-40 screw in the upper hole.

(32) Mount the right angle lug, Fig. 6-45 ⑥, under the 4-40 screw in the first hole and solder the 240 micro-microfarad "toothpick" capacitor to the lug. (Fig. 6-45 ⑥.)

(33) Take a piece of No. 20 or No. 22 wire,  $1\frac{1}{2}$ " long and solder one end to the active lead of the capacitor and the other end to the lug at the base of the fuse. (Fig. 6-45 ⑦.)

(34) Mount the four wiper springs on the cover in the following manner:

**NOTE:**

*Locate all the .122 diameter holes  $\frac{3}{8}$ " in from the edge of the cover.*

(a) Place the cover with the bottom side toward the operator (window uppermost). Fig. 6-42.)

(b) Drill two holes on the bottom left hand side, Fig. 6-42 ①, in the following manner: drill the first hole 1" from the left side, and placing the second hole  $\frac{7}{8}$ " c-c from the first hole.

(c) Drill two holes on the bottom right hand side, Fig. 6-42 ②, in the following manner: drill the first hole  $\frac{3}{4}$ " from the right edge, and place the second hole  $\frac{7}{8}$ " c-c from the first hole.

(d) Drill two holes on the right hand vertical edge, Fig. 6-42 ③, in the following manner: drill the first hole  $1\frac{5}{8}$ " from the bottom edge and place the second hole  $\frac{7}{8}$ " c-c from the first hole.

(e) Drill two holes on the top horizontal edge, Fig. 6-42 ④, in the following manner: drill the first hole  $\frac{3}{4}$ " to the left of the right vertical edge, and place the second hole  $\frac{7}{8}$ " c-c from the first hole.

(f) Fasten the spring wipers with  $.122" \times \frac{1}{8}"$  long rivets.

(g) Rivet securely.

(35) Replace the cover on the unit being careful to avoid damaging the spring wipers.

(36) Replace the four mounting screws on the sides.

(37) Replace the 6-32 flathead screws in the rear panel.

(38) Replace the 6-32 binderhead screw in the lower left hand corner of the cover.

(39) Reassemble in the reverse order of steps 1 through 7.

**10. WAVE TRAP F-19/UPR.**

a. No routine maintenance is required. However, good electrical contact between the elements of the wave trap "in-out" switch is important. The tension of this switch spring may need to be adjusted occasionally and should be checked immediately if any erratic action is observed when tuning the trap.

**11. WAVE TRAP F-20/UPR.**

a. No routine maintenance of Wave Trap F-20/UPR is required. However, good electrical contact between the tuning slider and the inner and outer conductors of the stub is important. The tuning slider contact fingers, should be inspected occasionally for even wear.

b. To inspect the sliding contact, move the tuning slider to the low frequency end of the stub. Remove the two screws at the bottom of the square tube. Remove the bracket and spacer. Remove the screw holding the lucite slide to the sliding contact (Fig. 1-15). Using a small screwdriver, gently work the sliding contact out of the bottom of the square tube. Bending the contact fingers slightly, in the proper direction to

increase contact pressure, is desirable before reassembly. This will insure "Clean" tuning action.

c. A complete spare sliding contact assembly, consisting of sliding contact, lucite slide, screw and lock-washer, is included with the equipment.

## 12. LUBRICATION.

### a. UNIVIS OIL No. 90.

Univis Oil No. 90 is applied to the felt washers

located at either end of the worm gear, Fig. 6-24, of the tuning unit. Do not apply too much oil as the excess may drip and interfere with the electrical operation of the tuning units.

### b. TEXACO GREASE TG-223.

Grease is applied to the fiber clutch gear and the (Fig. 6-24). Grease may also be applied, but sparingly, to all backlash gears and pinion gears.

## NOTE:

*In late model receivers, resistor R-127 has been changed from 1000 ohms to 1800 ohms (same as R-135). This change was made to increase the efficiency of the Heterotone Oscillator. Wherever the new type 6AC7W tubes are used be sure that R-127 is an 1800 ohm resistor.*



13. TROUBLE START.

<i>Trouble</i>	<i>Probable Causes</i>	<i>Remedy</i>
RECEIVER DEAD	Power switch off.	Turn on and off several times, rapidly.
	Fuse blown.	Replace with fuse from spares mounted on clips at rear of tuner housing. Check for line voltage. Should be 115V (limits 104 to 125). If less than 104V, change tap on transformer.
	Gain control off.	Advance control.
	Phones dead.	Replace.
	Phone jack open.	Try other phone jack. Replace.
	Tuner dead.	Make certain tuner is plugged in all the way. Check antenna connection. Change tubes or crystal in tuner.
	I. F. Amplifier dead.	Refer to trouble shooting under AM-12/APR-1, Section 5, paragraph 4.
	Shorted antenna plug.	Clear short with tool or replace plug. See Navships 900,081.
	Tuner butterfly plates shorted.	Attempt to clear short with air blast, or other means if reason for short invisible. Reject tuner if damage is serious, bending plates will destroy the calibration of the unit.
	Plus B or Heater lead short in tuner.	Look for short caused by breakdown of mica insulator washer where power leads enter the tuner casting. Replace washer, or try substitute.

TROUBLE CHART (con't)

<i>Trouble</i>	<i>Probable Causes</i>	<i>Remedy</i>
RECEIVER WEAK	Antenna line shorted or open. Antenna switch defective.	Replace line or antenna. Short around switch temporarily, repair switch.
	Burned or defective crystal in tuner.	Replace crystal.
	Defective tube in tuner.	Replace tube.
	Tuner not aligned properly.	Realign tuner. Section V, paragraphs 5 and 6.
	Antenna plug not contacting.	Make certain the contacts make in the antenna plug and chassis receptacle. Bend contacts if possible. Replace connectors.
	Use of headset of wrong impedance.	Headphones should be 600 ohm. If of higher impedance, change tap on output transformer.
	I. F. Amplifier (AM-12/APR-1 defective.	Refer to the trouble shooting procedures under I. F. Amplifier Strip, Section V, paragraph 4.
	Defective auxiliary equipment.	Refer to the instruction manuals for the respective equipment.
	Low line voltage.	If line voltage is less than 104 volts, change tap on power transformer, in PP-10/APR-1 to 80 volt tap. (Fig. 6-56.)
Gain control set too low.	Check setting of gain control.	
ERRATIC OR NOISY RECEPTION	Defective tuner.	Remove tuner and replace tuner. If still noisy or erratic, the trouble is in the I. F. Amplifier (AM-12/APR-1). Refer to trouble shooting under this head, Section V, paragraph 4.
	Loose or improper bonding of cables or incidental wiring in the vicinity of receiver.	Localize the trouble by removing all such leads. See Navships 900,081.

## SECTION VI — SUPPLEMENTARY DATA

### 1. GENERAL.

The following summary covers Radio Receiving Equipment AN/APR-1 and AN/SPR-1 and equipment similar in construction and purpose. The equipments share the following common properties:

a. Cover a frequency range of 40-3000 megacycles in four bands, covered by means of complete removable tuning units.

b. Incorporate an I-F and power supply unit on a master chassis having provision to receive the plug-in tuning unit.

c. All are intended to receive and analyzer the characteristics of radar pulsed signals and to deliver information aurally, on suitable meters, or other auxiliary devices not necessarily an integral part of the basic equipment.

d. All units utilize the super-heterodyne principle of reception.

The various versions of this equipment were brought out since 1941 by various manufacturers and N D R C. Each unit is listed by its commonly used designation and a brief description follows, giving the essential features of each equipment. Further information should be obtained from the respective instruction manuals, describing the characteristics of the various types of plug-in tuning units which have appeared in the field, and careful note should be taken of the descriptions contained herein, and of the chronology given in approximate figures. It is to be noted that this information is that available to the Galvin Mfg. Corp. at that time, and as such is not likely to be absolutely accurate in every detail, nor complete. It is intended as a guide to the development of a more complete summary.

### 2. SUMMARY OF BASIC CHASSIS.

#### a. MODEL ARC-1.

Model ARC-1 is primarily an aircraft type of receiver, having the following features: utilizes 12 volts D-C as primary power source; incorporates a dynamotor; 100 ohm video output; audio gain control; heterotone oscillator; 600 ohms headphone output.

Originally designed to operate with two tuning units, manually operated, covering 80 to 370 and 290 to 450 megacycles. These tuning units cannot be used

on a chassis having provision for the motor driven feature unless a third hole is drilled into the rear of the casting to clear the 28 volt D-C plug. Model ARC-1 cannot be used with a Panoramic Adapter and does not have an A. V. C. on-off switch.

#### b. RADIO RECEIVING EQUIPMENT AN/APR-1 and AN/SPR-1.

The differences in Radio Receiving Equipment AN/APR-1 and AN/SPR-1 are as follows:

(1) Radio Receiving Equipment AN/APR-1 designates an airborne installation with light weight shock mounting base and dust cover, aircraft type cable and antennae.

(2) Radio Receiving Equipment AN/SPR-1 designates a shipborne installation, utilizing a heavy shock mounting base and dust cover, shipborne antennae and armored cable.

Radio Receiving Equipment AN/APR-1 and AN/SPR-1 has the following features: Operates at 117 volts, single phase, 60 to 2600 cycles; I-F has 2 megacycles band width at 2 times down; gain control in I-F amplifier stages, has scale for setting gain, A. V. C. with switch; provision for Panoramic Adapter on panel, take-off from last I-F Plate; I-F Gain 80 D. B.; heterotone oscillator; 600-8000 ohms headphone output, two jacks; video output, 50 ohms, on front panel.

#### c. MODEL AN/APR-4.

Model AN/APR-4 is similar to Radio Receiving Equipment AN/APR-1 and AN/SPR-1, having the following features: 4 megacycles band width, provided with a switch to decrease band width to .5 megacycles; gain control in I-F, calibrated in approximately 2 D. B. steps, switch type, A. V. C. control switch on gain switch; output for panoramic adapter, and video; heterotone oscillator; 600-8000 ohm impedance headphone output, twin phone jacks; A-C operated, 115 volts single phase 60-2600 cycles; has 28 volt plug for motor driven tuners; 90 D. B. gain.

#### d. MODEL R. D. O.

Model R. D. O. unit is primarily designed for the Navy. General characteristics are similar to Radio Receiving Equipment AN/APR-1 and AN/SPR-1, but has greater band width and gain, heavier construction.

### 3. SUMMARY OF TUNERS.

*a.* Tuning units CPR-47AAE and CPR-47AAF, Navy type CRP-46ABC for Model ARC-1 are manually operated. They utilize the butterfly type of tuned circuits. Not interchangeable in late type chassis which have additional plugs for 28 volt D-C power for motor drive. (See Section I, paragraph 10 *c.*)

*b.* Tuning Units TU-58B and TU-57B, known also as TN-2A/APR-1 and TN-3A/APR-1 are automatic sweep units, covering 74 to 300 and 300 and 1000 megacycles. The sweep feature is continuous. They can be used in Model ARC-1 (without automatic feature) or in Models AN/APR-1 and AN/SPR-1, AN/APR-4 and R. D. O., when proper connections are made to supply D-C power through main power plug of basic chassis.

A TN-1A/APR-1 was also produced, embodying an auto-sweep feature. These units were produced for the U. S. Army, but some were diverted for Naval usage.

*c.* Tuning Units TN-1/APR-1, TN-2/APR-1 and TN-3/APR-1 were designed primarily for Radio Receiving Equipment AN/APR-1 and AN/SPR-1, although they can be used in any of the other basic chassis. They are manually operated.

*d.* Tuning Units TN-1B/APR-1, TN-2B/APR-1, and TN-3B/APR-1 are sector sweep tuners, for the Bureau of Ships. Any given range of frequencies can be covered instead of the entire band as with the tuning unit TN-4A/APR-1. All improvements made in the manual tuners are incorporated in the Sector Sweep units.

*e.* A series of tuners designated as TN-16/APR-4, TN-17/APR-4, TN-18/APR-4, and TN-19/APR-4 are being produced specifically for Model AN/APR-4. These tuners are sector sweep types and interchangeable in all basic chassis. Automatic features require 28 volt D-C power source.

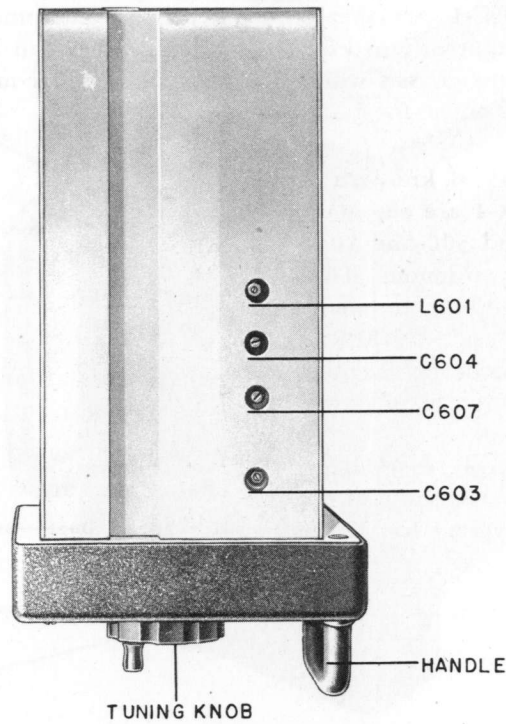

Figure 6-1. Tuning Unit TN-1/APR-1, Top View.

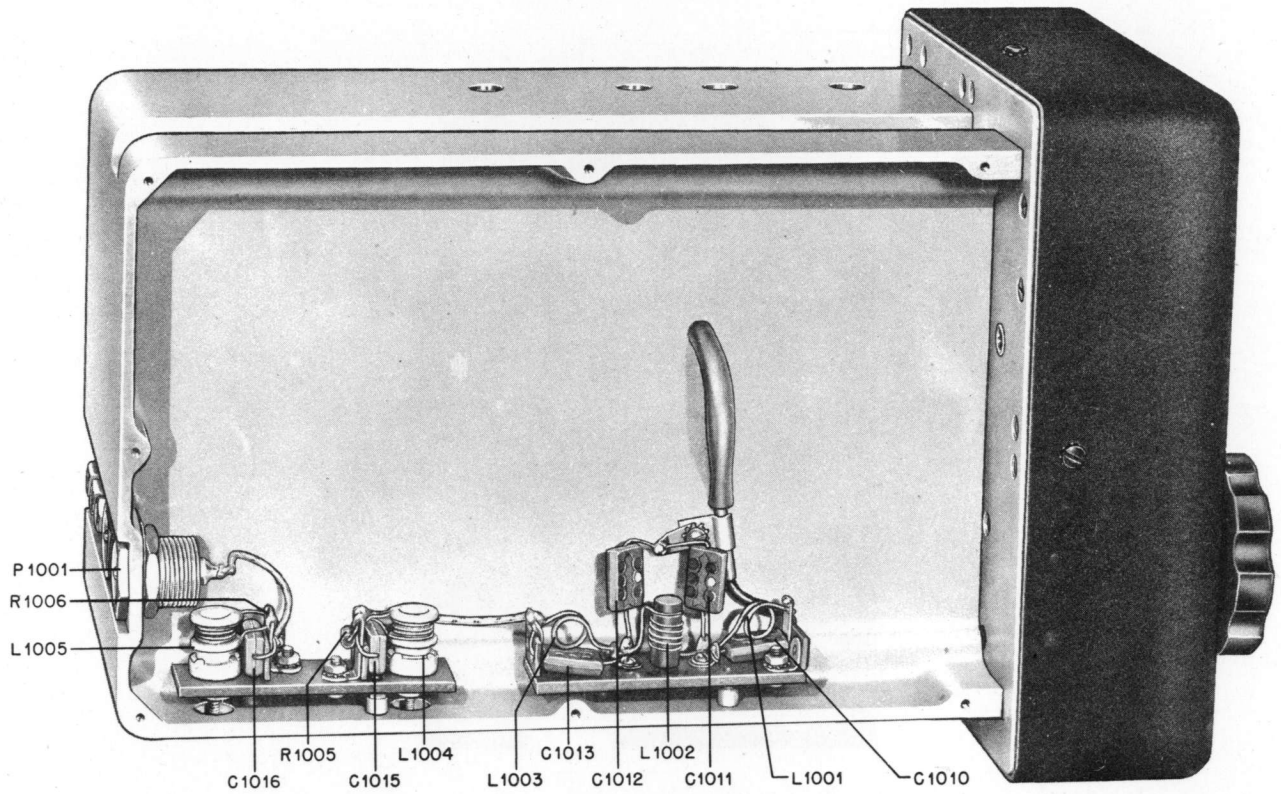

Figure 6-2. Tuning Unit TN-1B/APR-1, Left Side View.

RESTRICTED  
AN-16-30APR-1-3  
NAVSHIPS 900, 483A

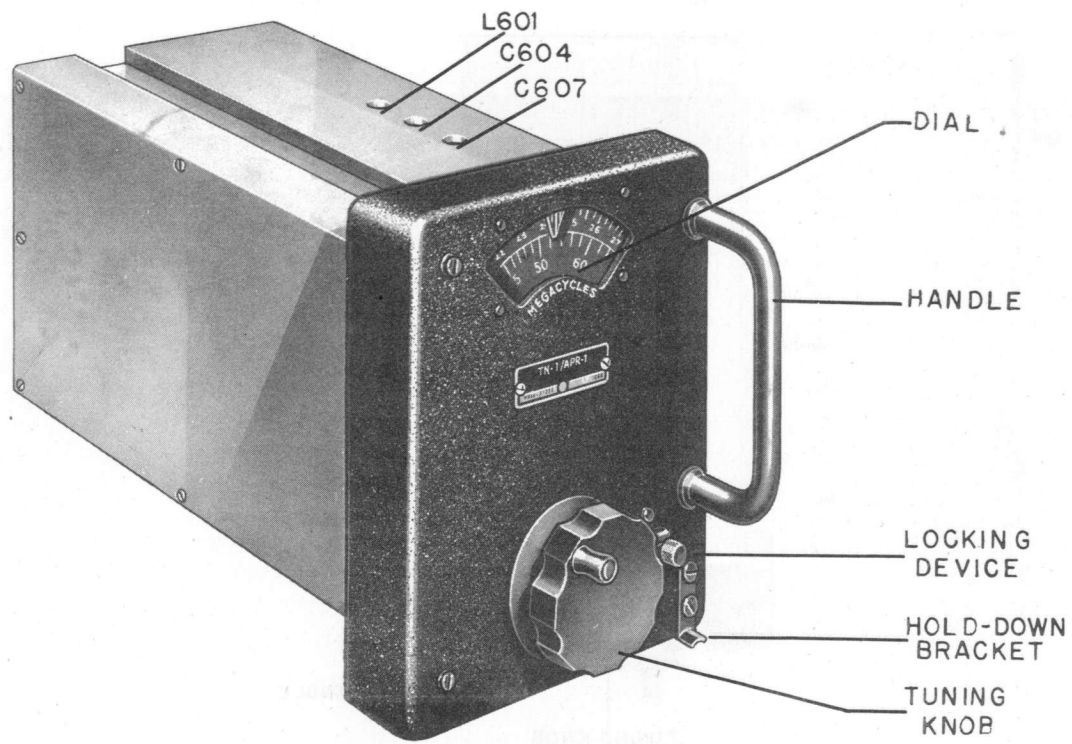

Figure 6-3. Tuning Unit TN-1/APR-1, Left Front Oblique View.

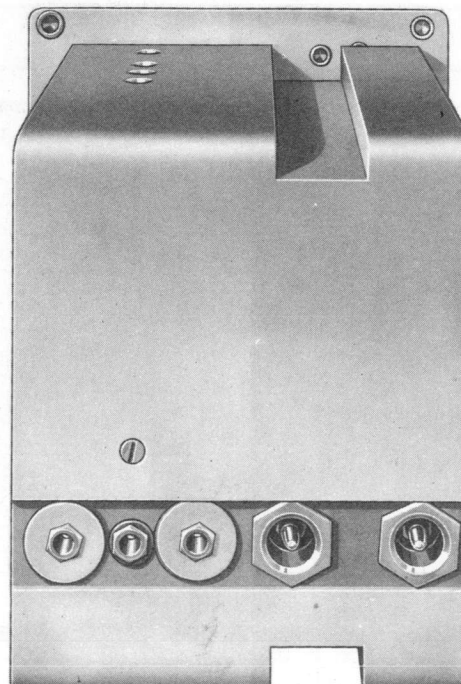

Figure 6-4. Tuning Unit TN-1/APR-1, Rear View.

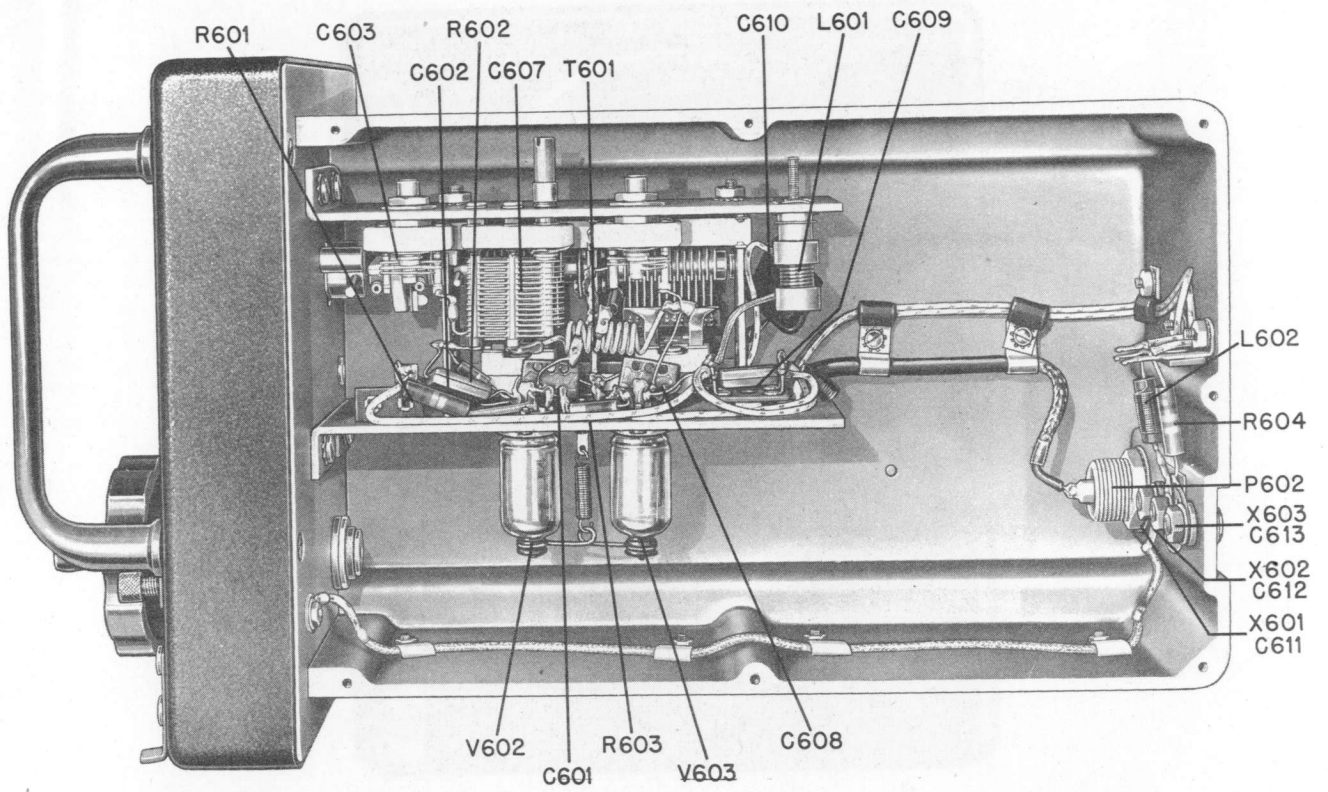

Figure 6-5. Tuning Unit TN-1/APR-1, Right Side View.

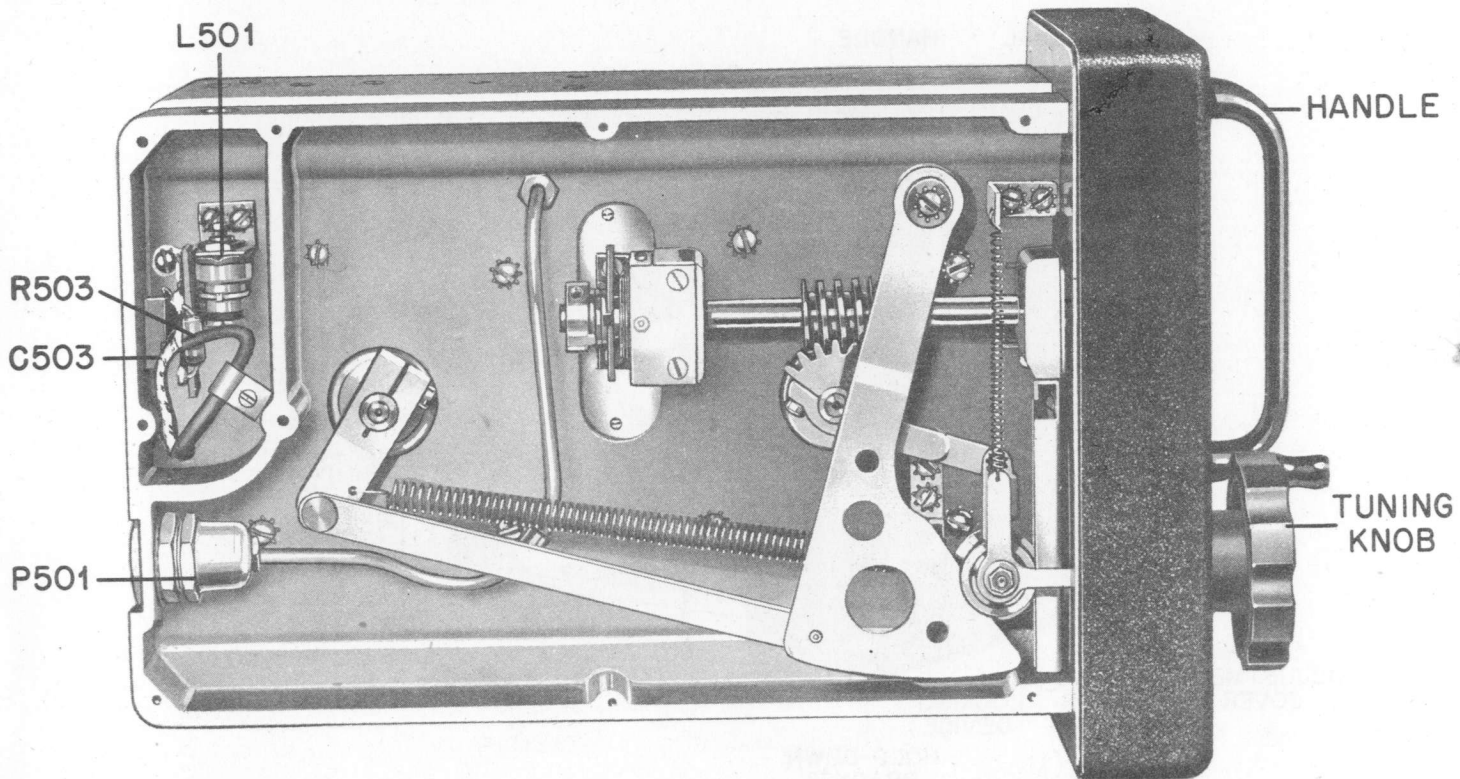

Figure 6-6. Tuning Unit TN-2/APR-1, Left Side View.

RESTRICTED  
AN-16-30APR-1-3  
NAVSHIPS 900, 483A

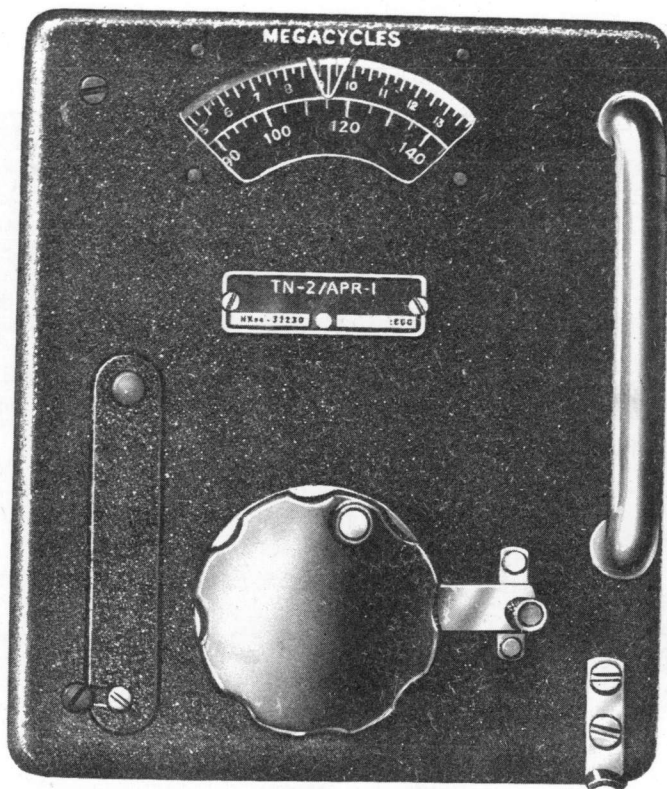

Figure 6-7. Tuning Unit TN-2/APR-1, Front View.

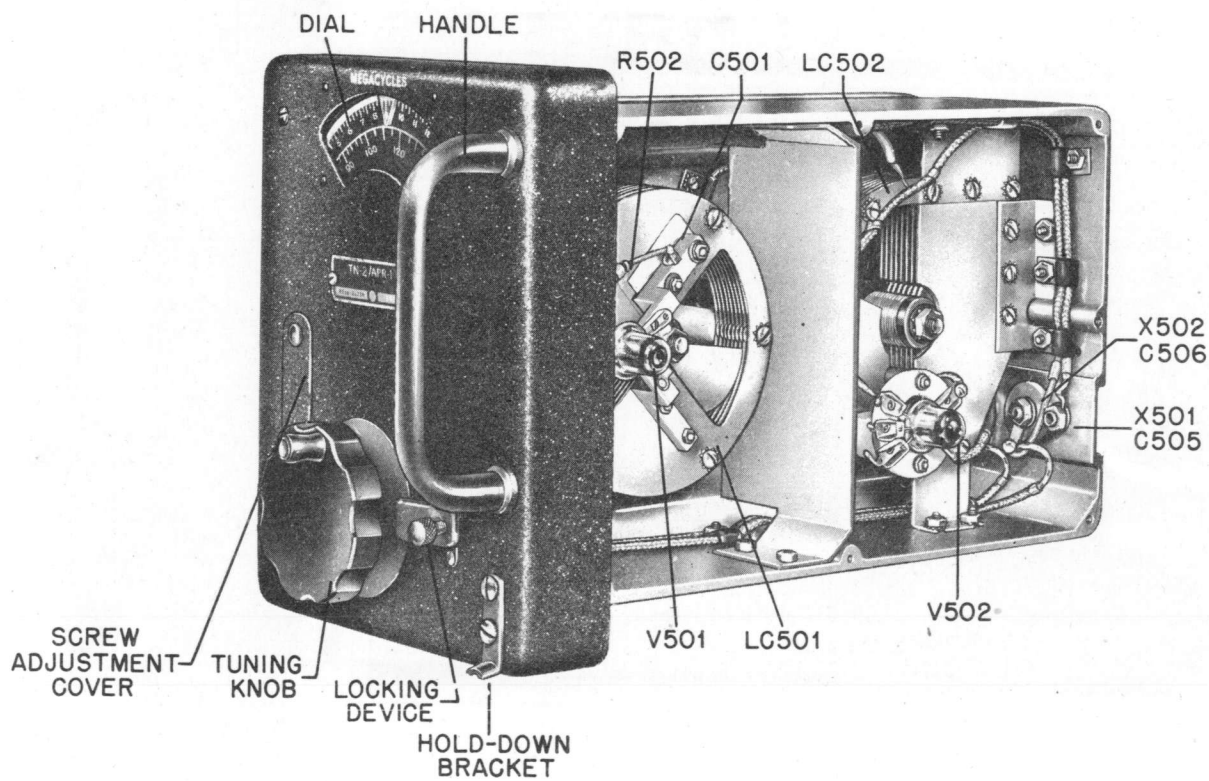

Figure 6-8. Tuning Unit TN-2/APR-1, Right Front Oblique View.



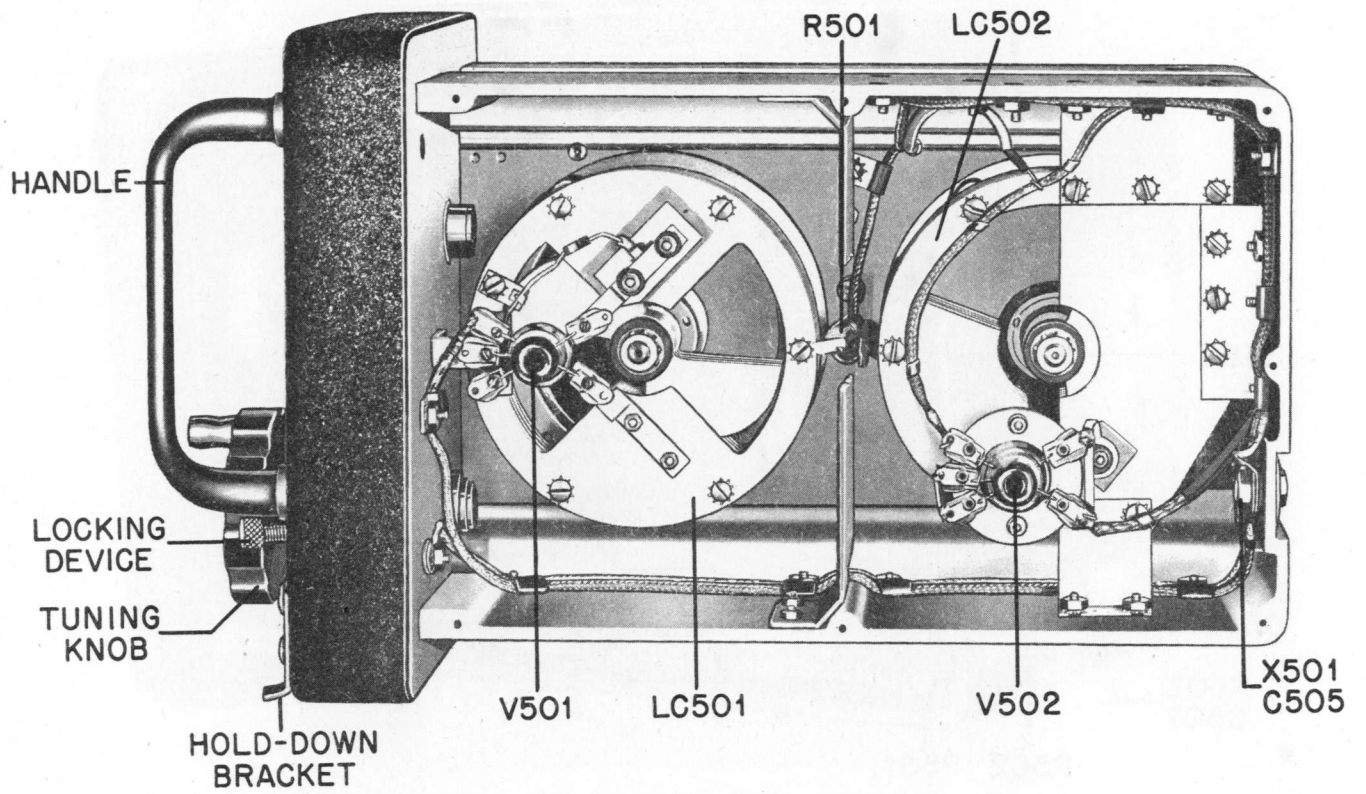

Figure 6-9. Tuning Unit TN-2/APR-1, Right Side View.

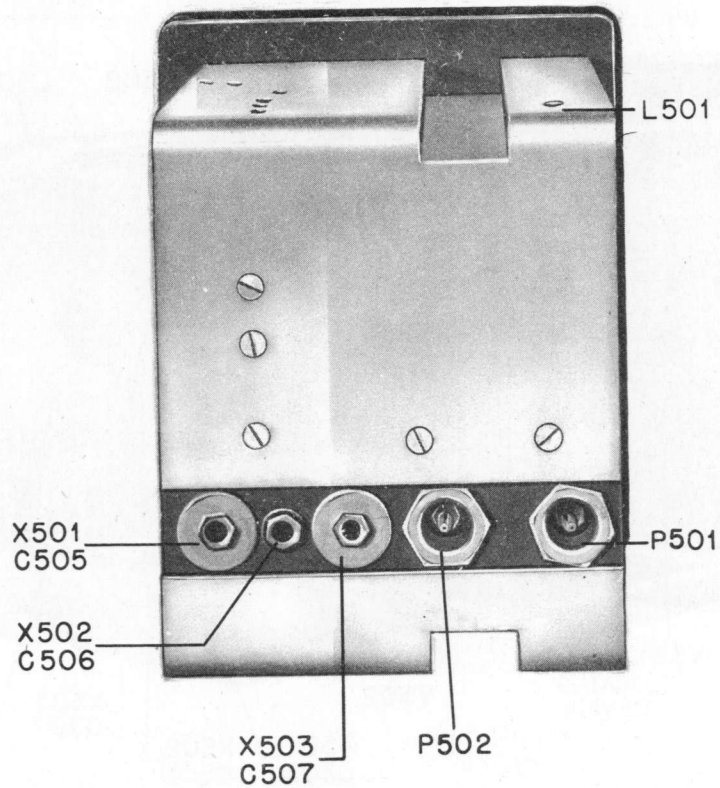

Figure 6-10. Tuning Unit TN-2/APR-1, Rear View.

RESTRICTED  
AN-16-30APR-1-3  
NAVSHIPS 900, 483A

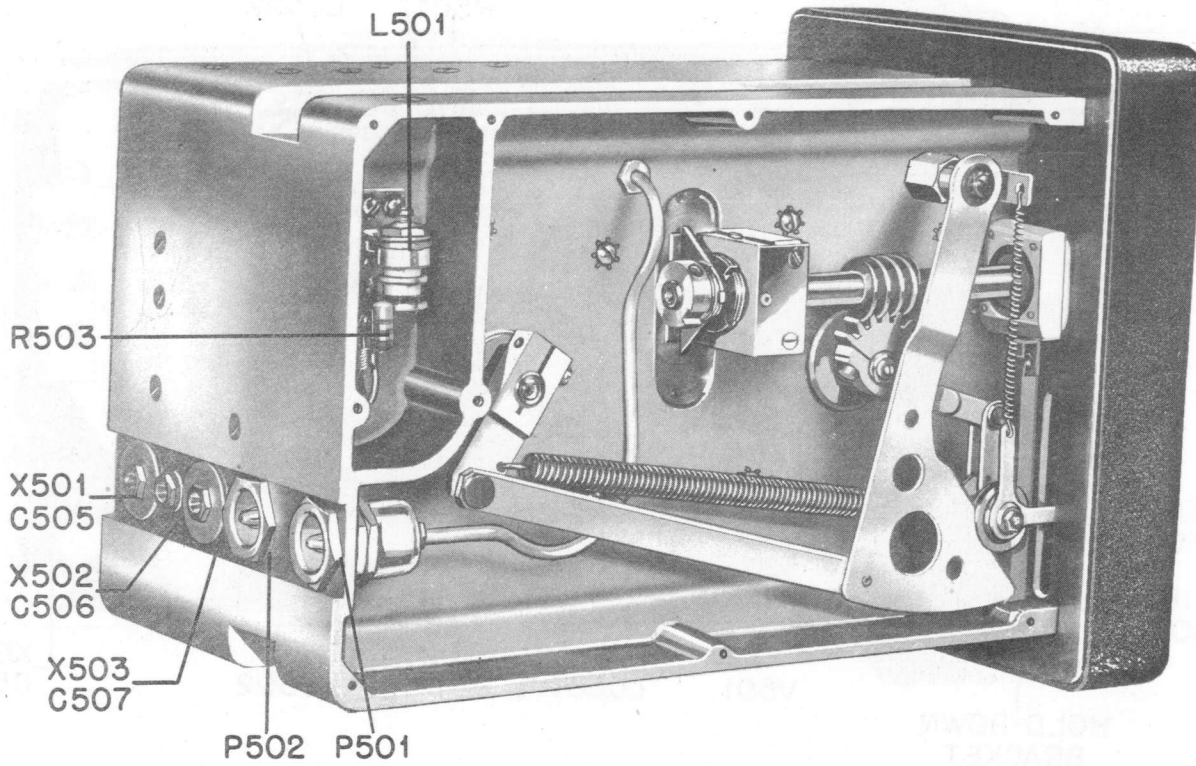

Figure 6-11. Tuning Unit TN-2/APR-1, Rear Right Oblique View.

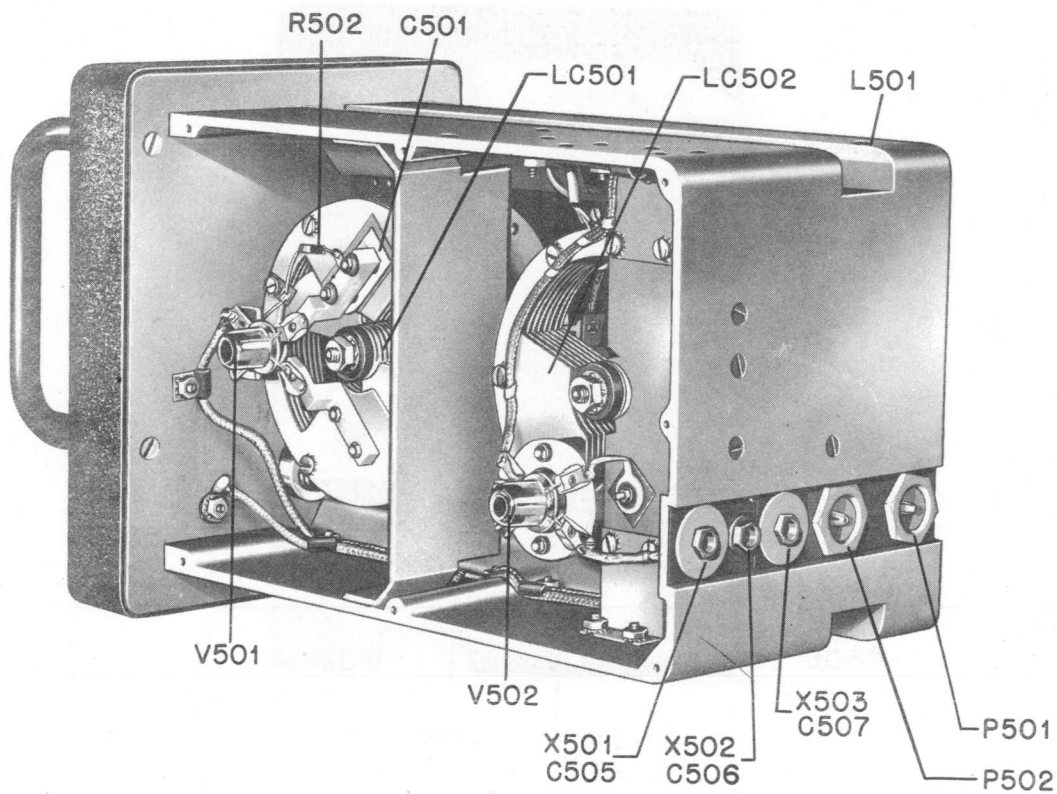

Figure 6-12. Tuning Unit TN-2/APR-1, Rear Left Oblique View.

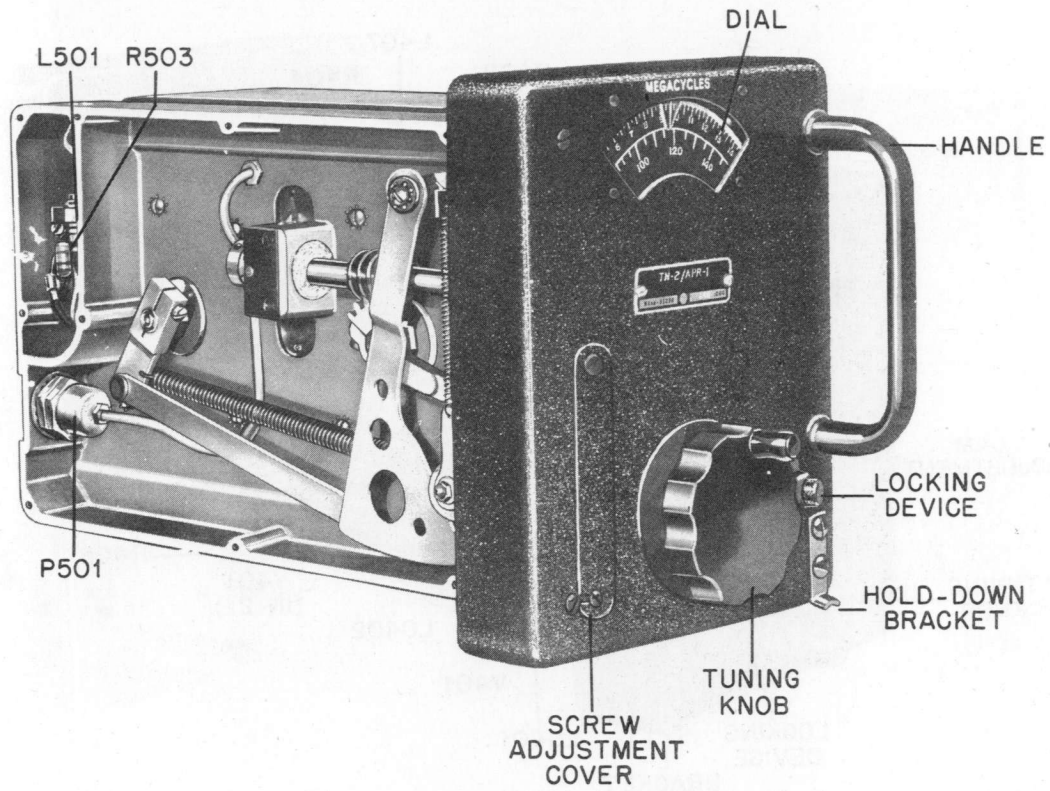

Figure 6-13. Tuning Unit TN-2/APR-1. Left Front Oblique View.

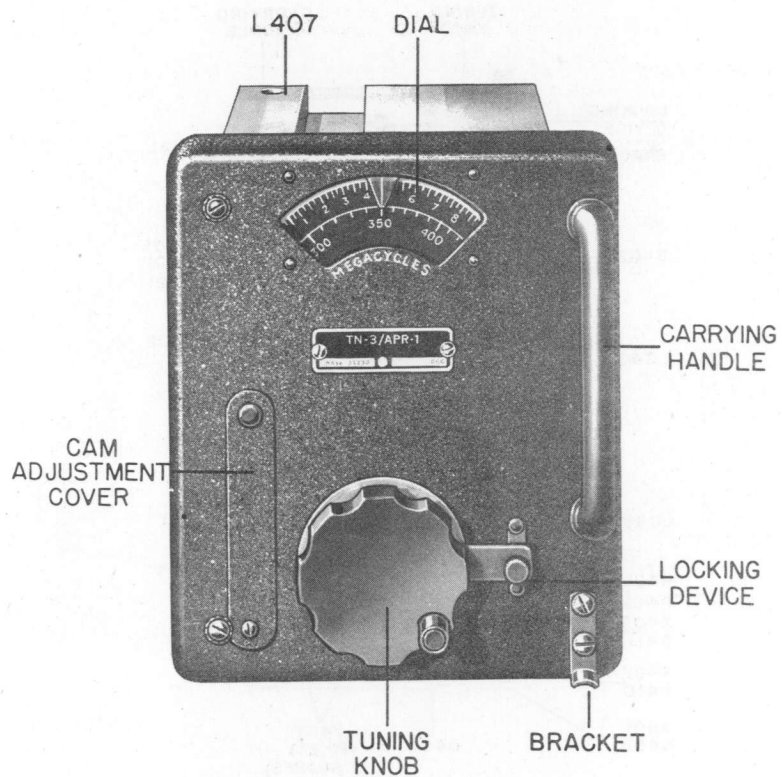

Figure 6-14. Tuning Unit TN-3/APR-1, Front View.

RESTRICTED  
AN-16-30APR-1-3  
NAVSHIPS 900, 483A

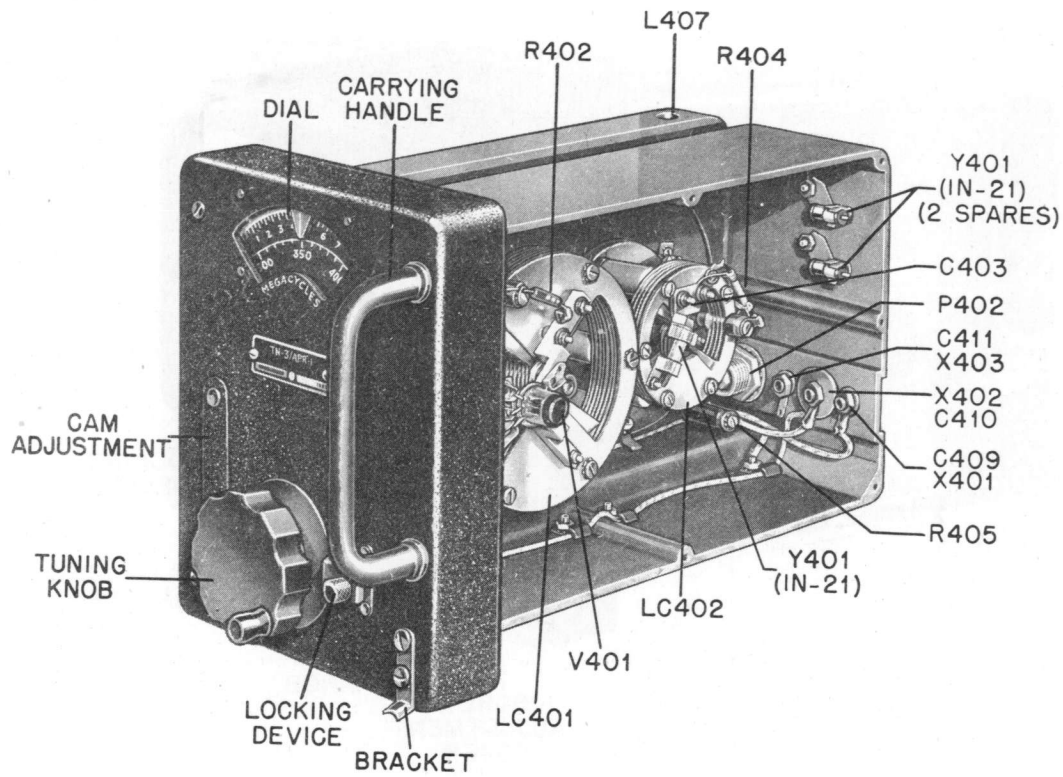

Figure 6-15. Tuning Unit TN-3/APR-1, Right Front Oblique View.

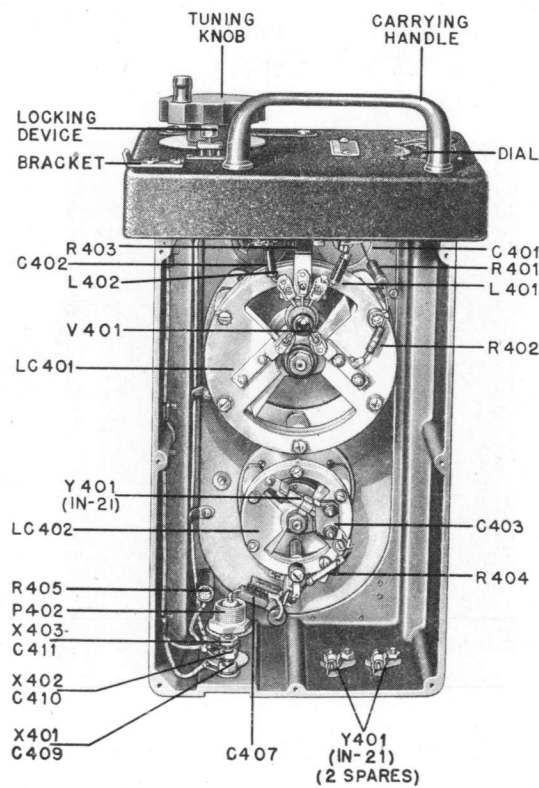

Figure 6-16. Tuning Unit TN-3/APR-1, Right Side View.

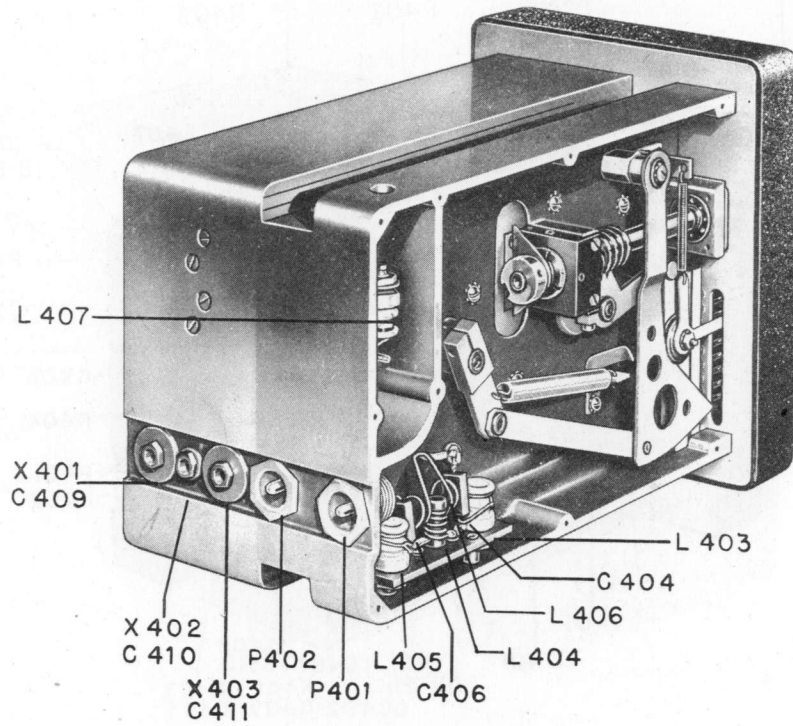

Figure 6-17. Tuning Unit TN-3/APR-1, Rear Left Oblique View.

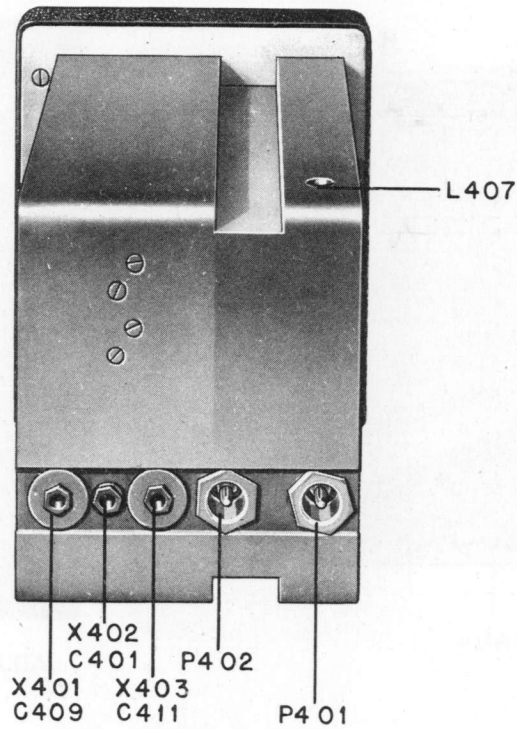

Figure 6-18. Tuning Unit TN-3/APR-1, Rear View.

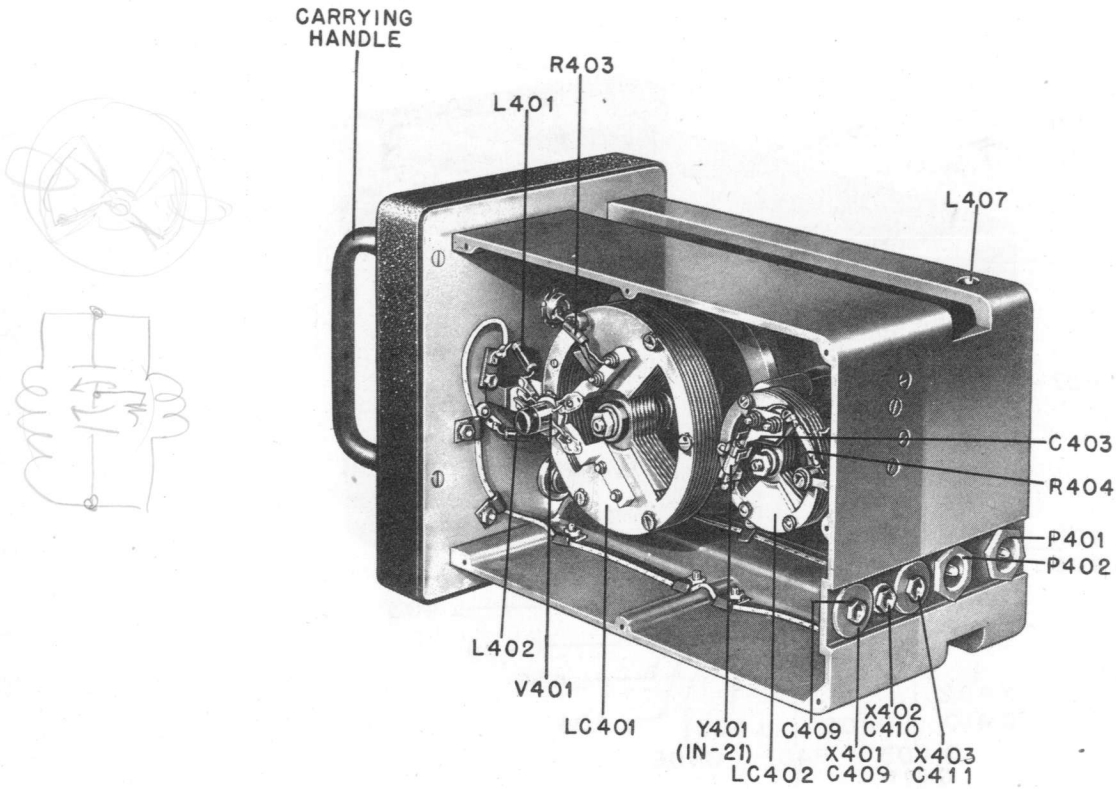

Figure 6-19. Tuning Unit TN-3/APR-1, Rear Right Oblique View.

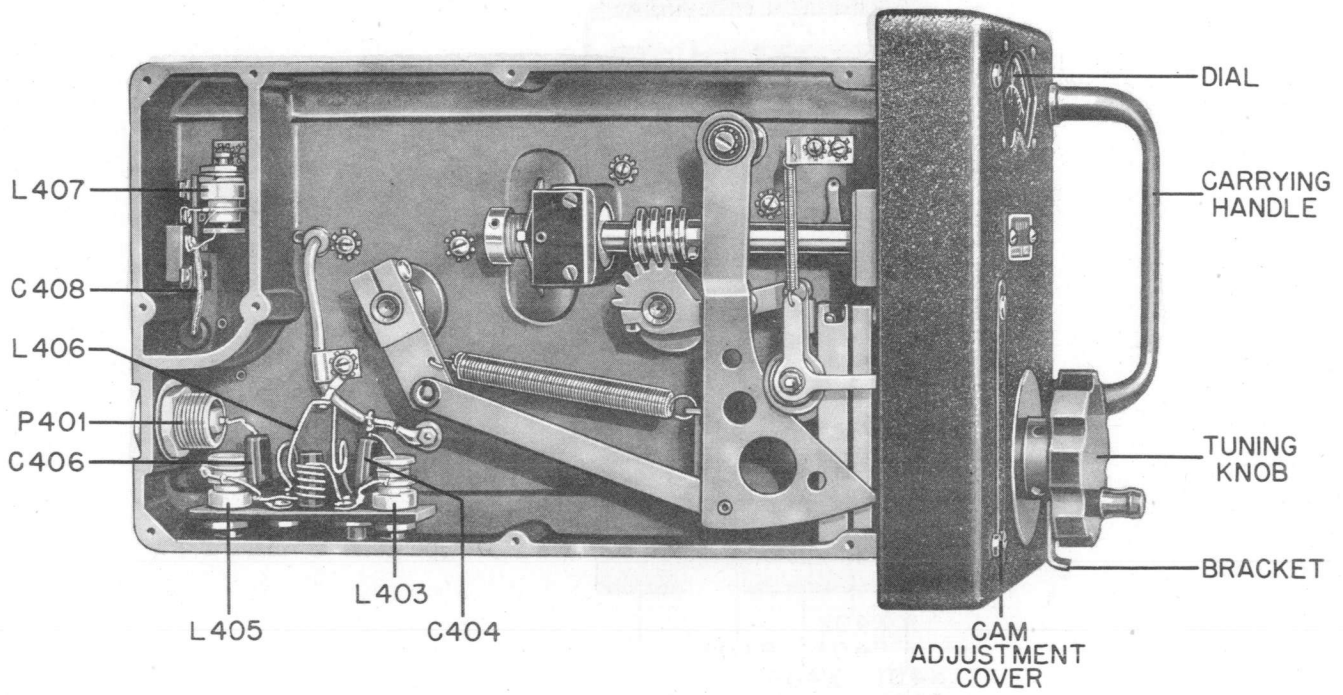

Figure 6-20. Tuning Unit TN-3/APR-1, Left Side View.

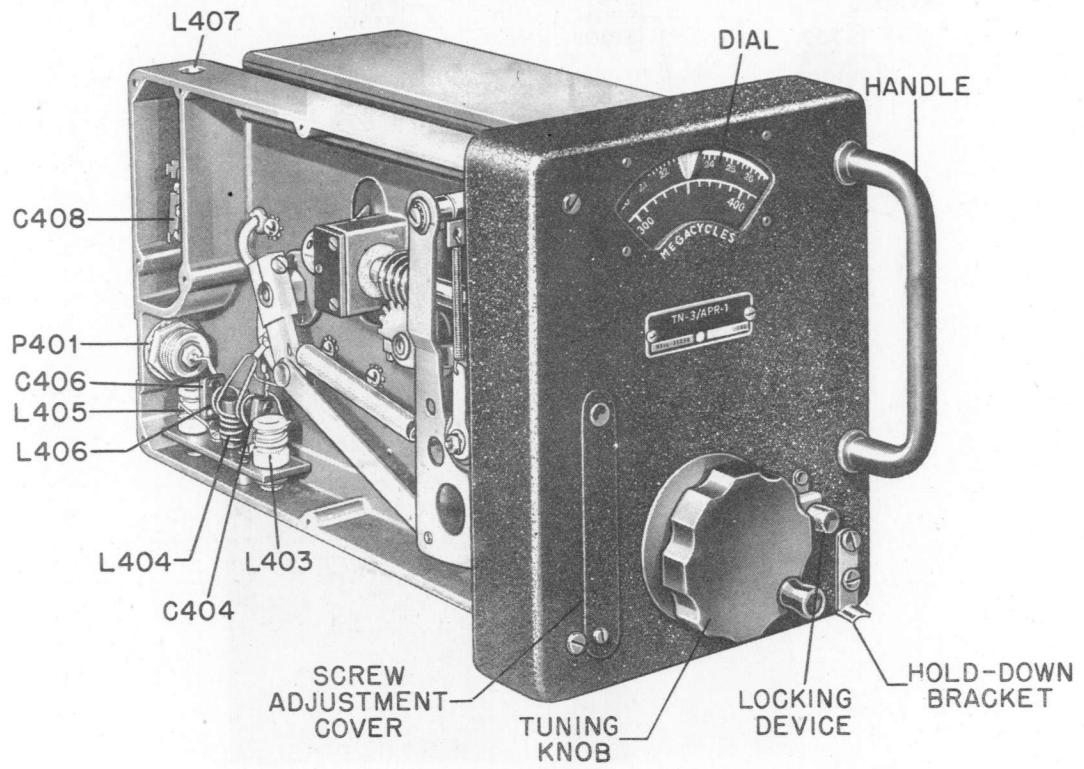

Figure 6-21. Tuning Unit TN-3/APR-1, Front Left Oblique View.

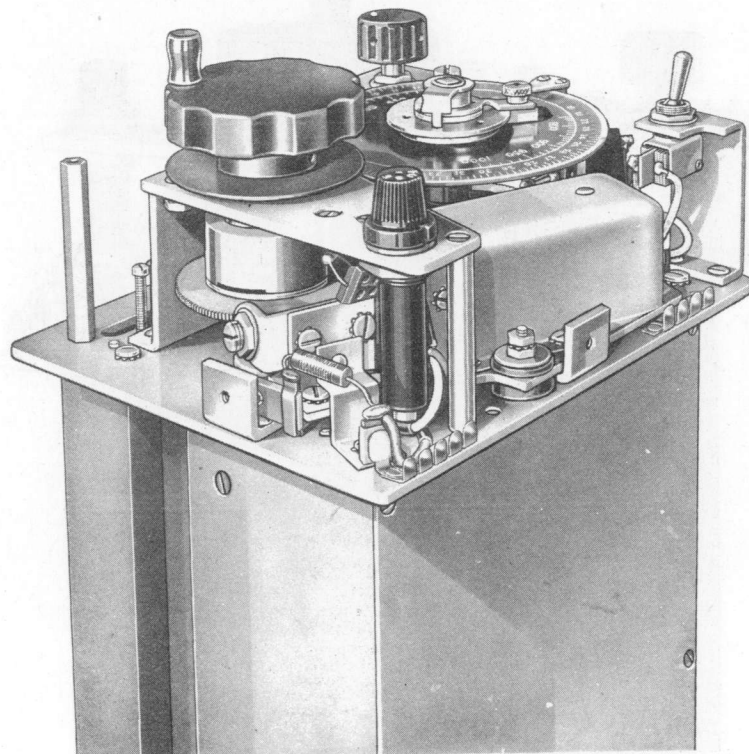

Figure 6-22. Sector Sweep Tuner, Top Left Oblique.

RESTRICTED  
AN-16-30APR-1-3  
NAVSHIPS 900, 483A

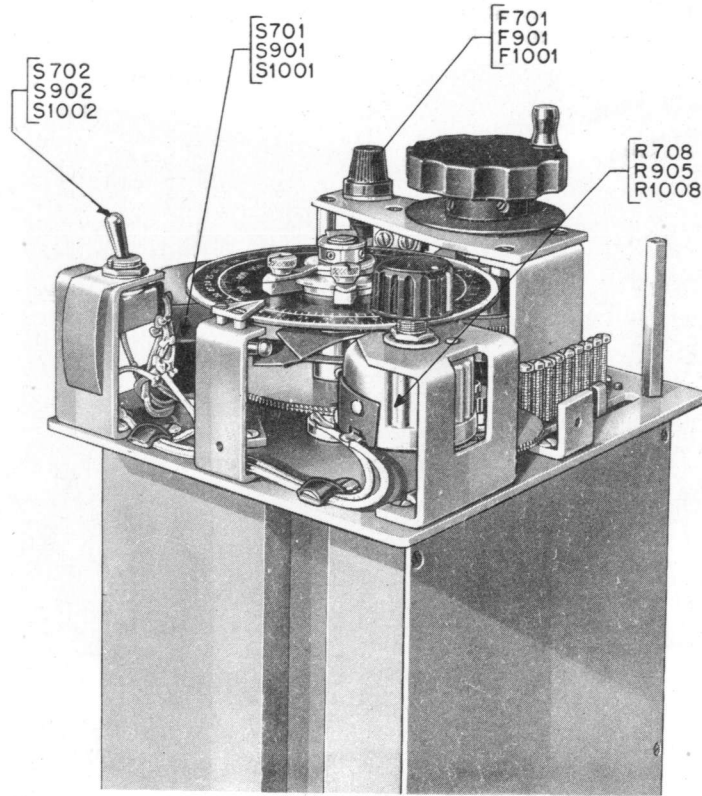

Figure 6-23. Sector Sweep Tuner, Parts Location, Bottom Right Oblique.

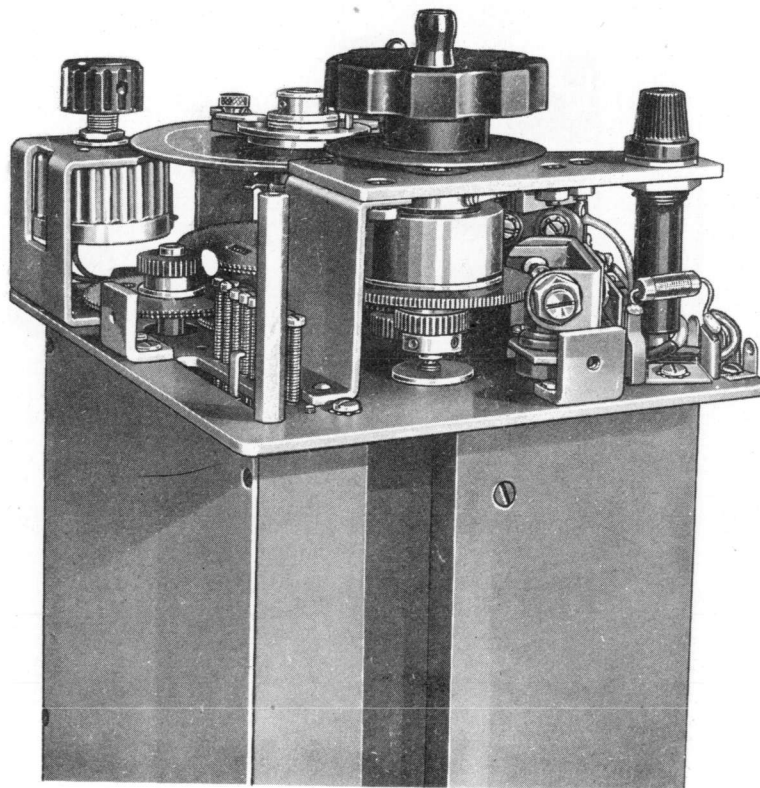

Figure 6-24. Sector Sweep Tuner, Bottom Left Oblique.



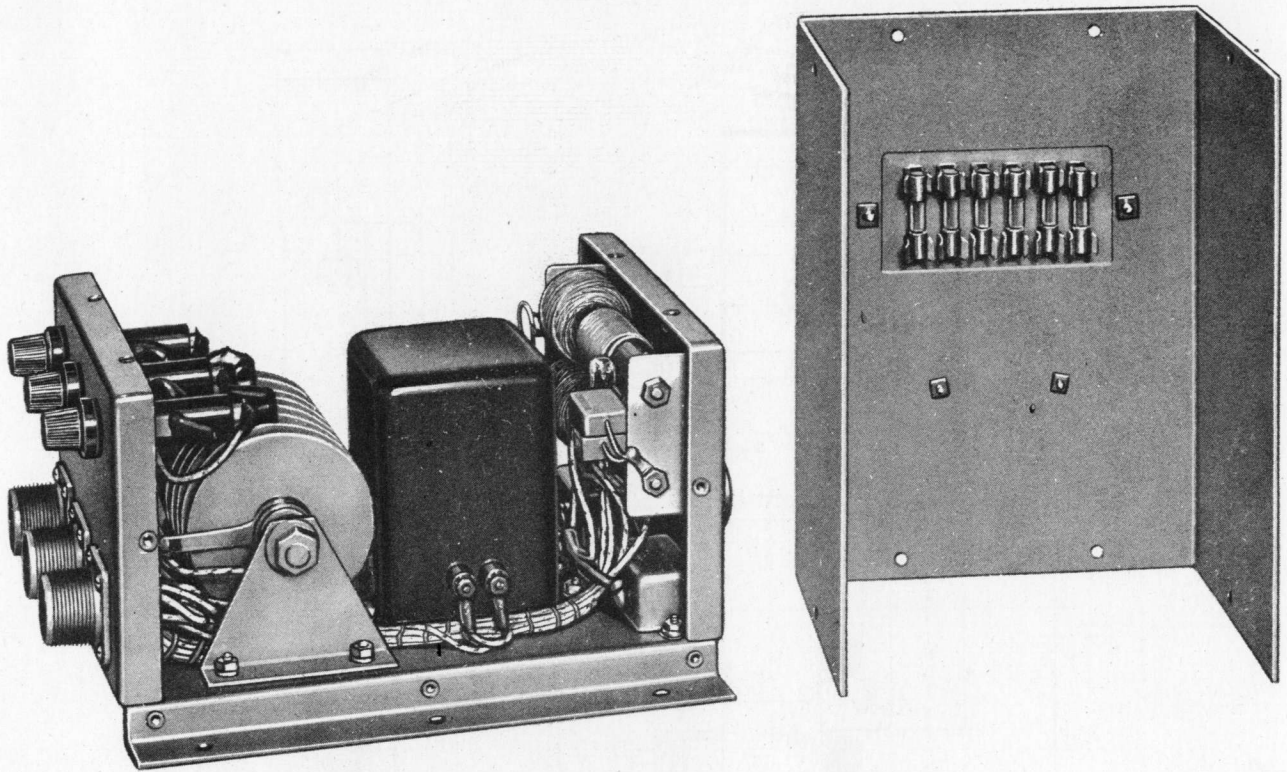

Figure 6-25. Rectifier Filter Unit PP-183/SPR-1, Right Oblique, with Cover.

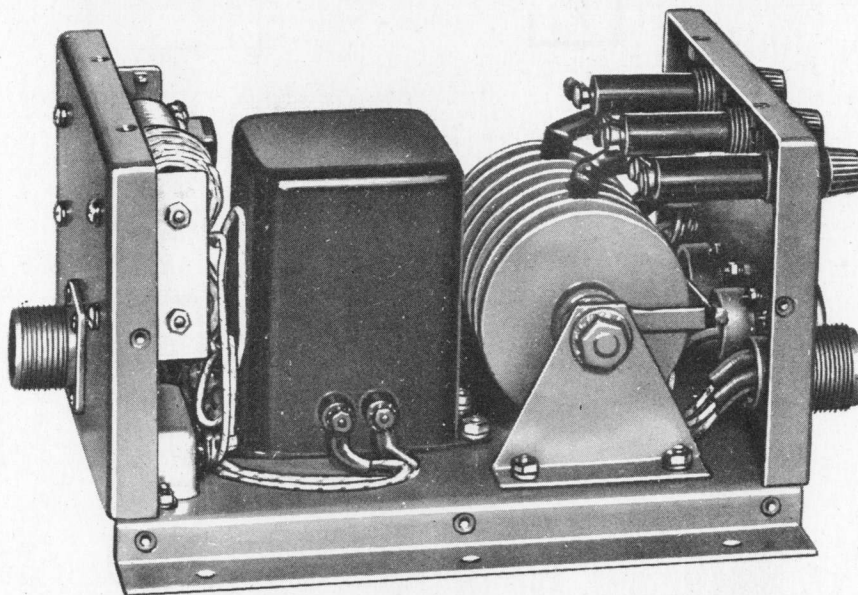

Figure 6-26. Rectifier Filter Unit PP-183/SPR-1, Left Oblique.

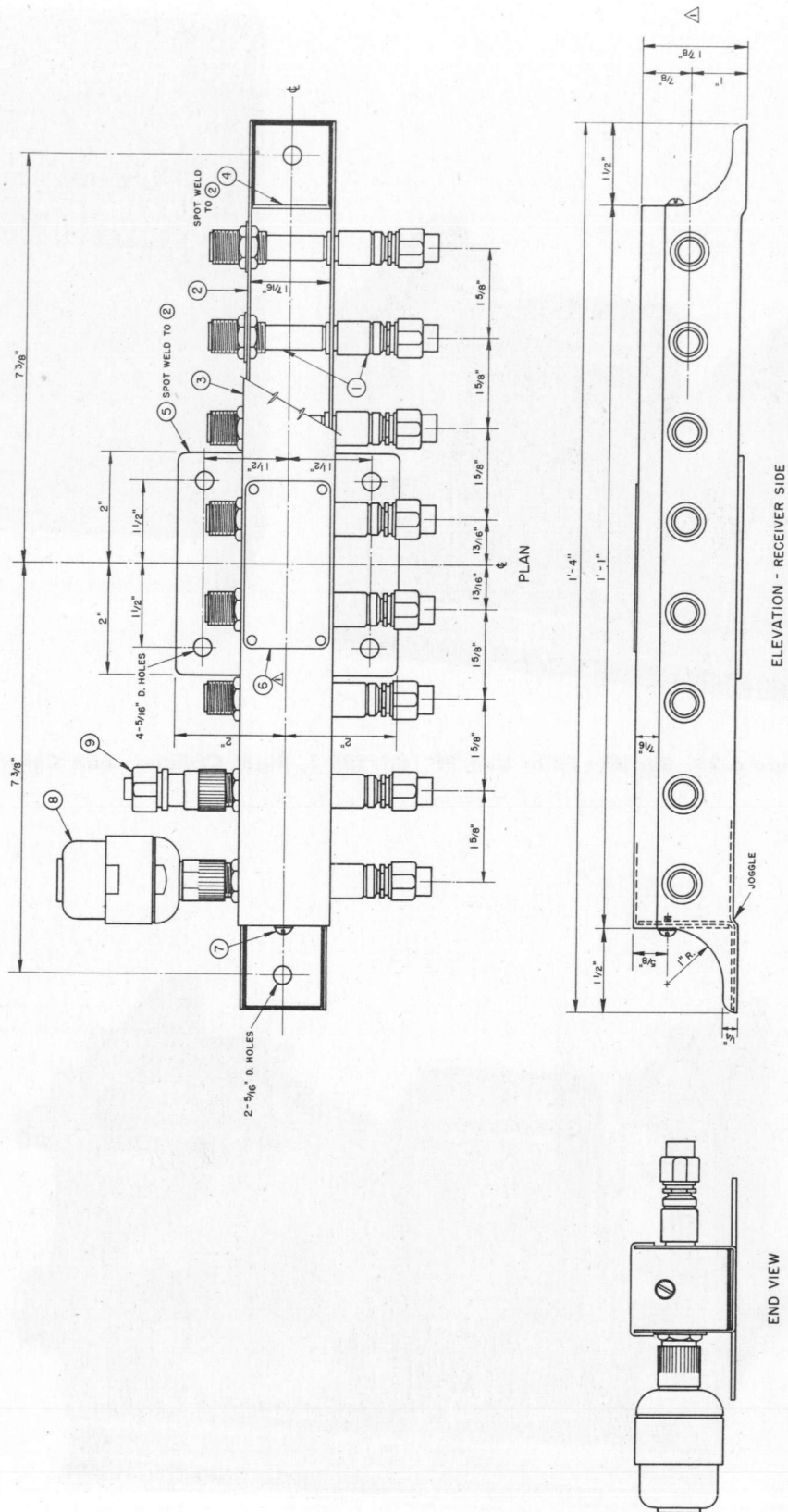

Figure 6-27. Jack Box J-116/SPR Diagram.

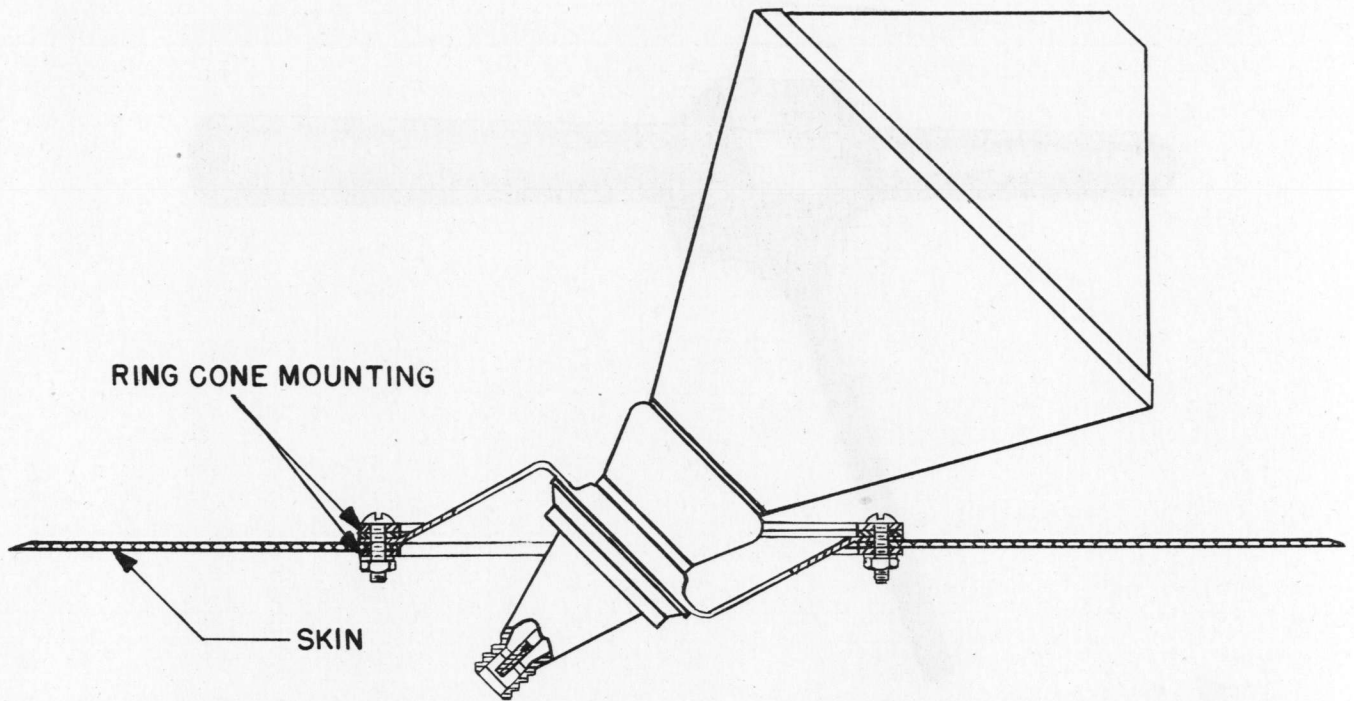

Figure 6-28. Antenna AS-124/APR Outline.

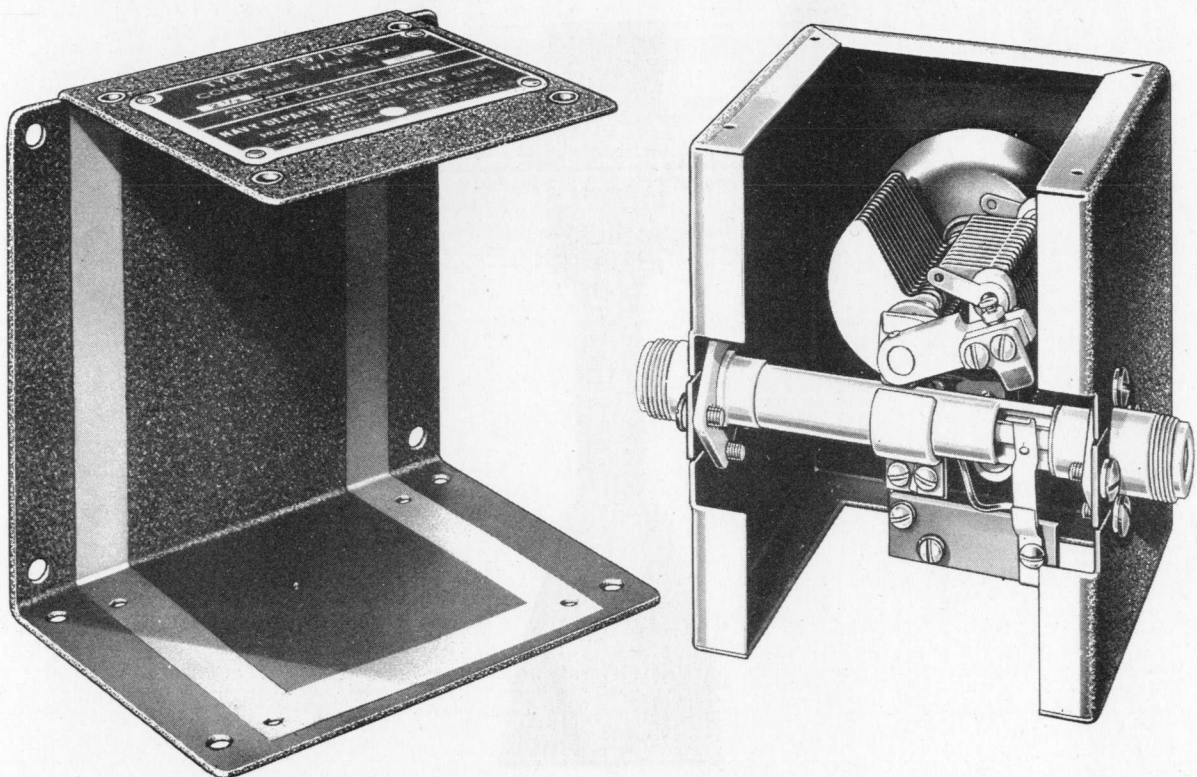

Figure 6-29. Wave Trap F-19/UPR, Open View.

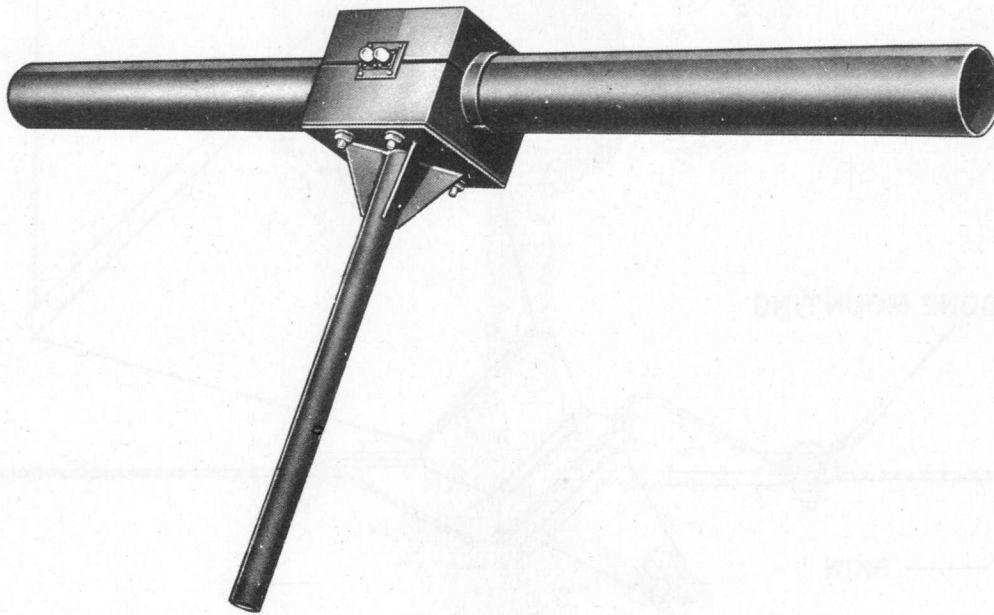

Figure 6-30. Dipole Antenna AS-56/SPR-1.

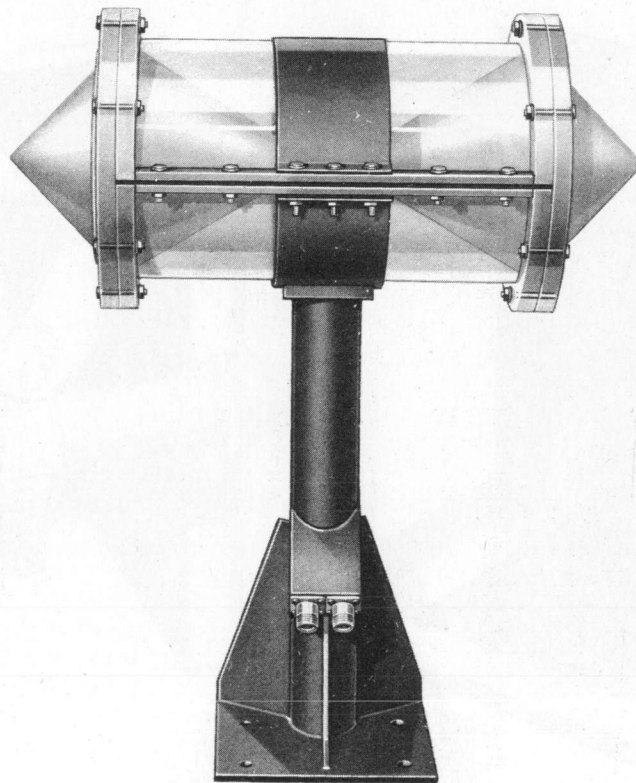

Figure 6-31. Double Cone Antenna AS-57/SPR-1, Side View.

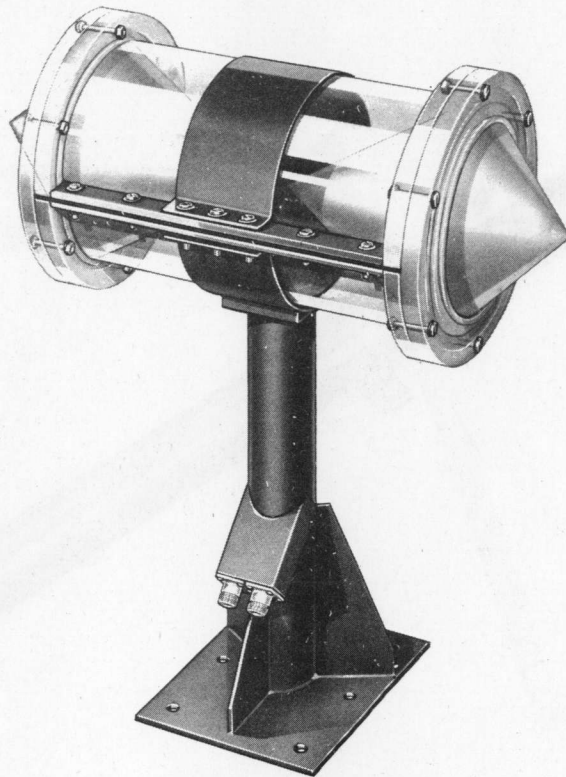

Figure 6-32. Double Cone Antenna AS-57/SPR-1, Oblique View.

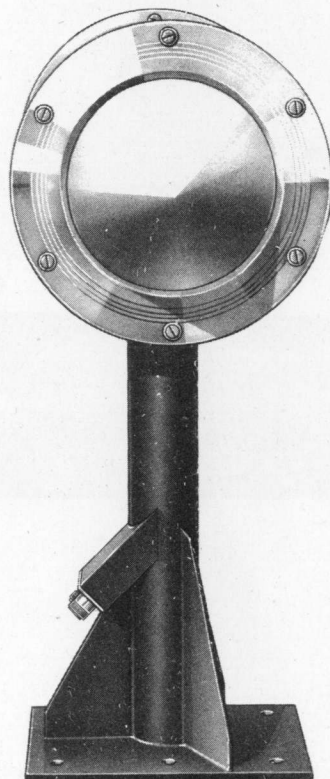

Figure 6-33. Double Cone Antenna AS-57/SPR-1, End View.

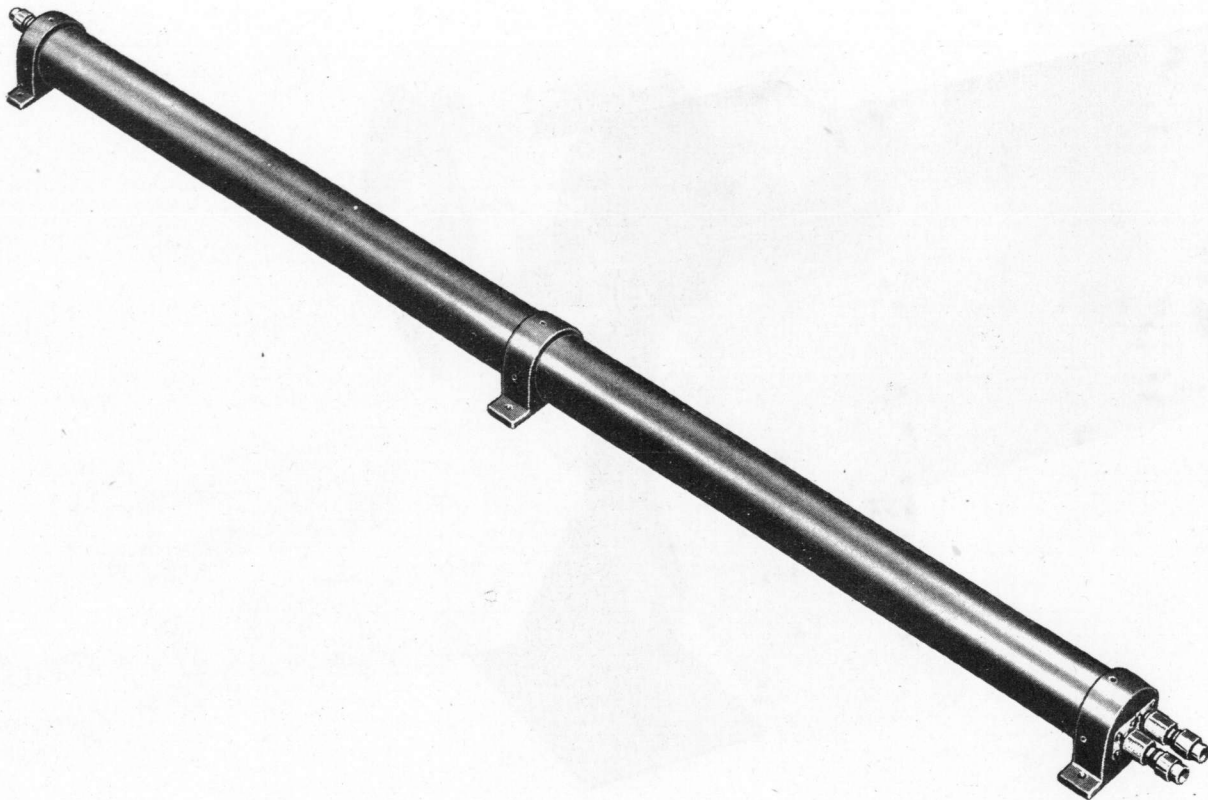

Figure 6-34. Impedance Matching Transformer CU-19/SPR-1.

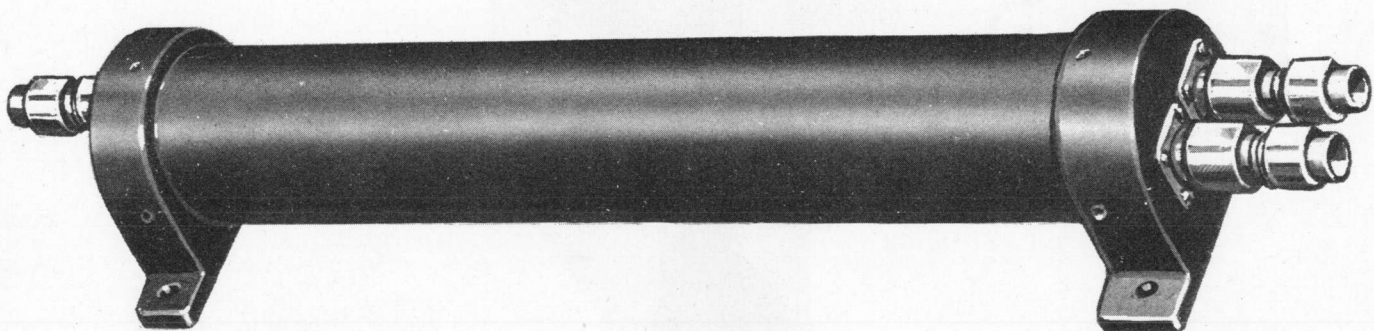

Figure 6-35. Impedance Matching Transformer CU-27/SPR-1.

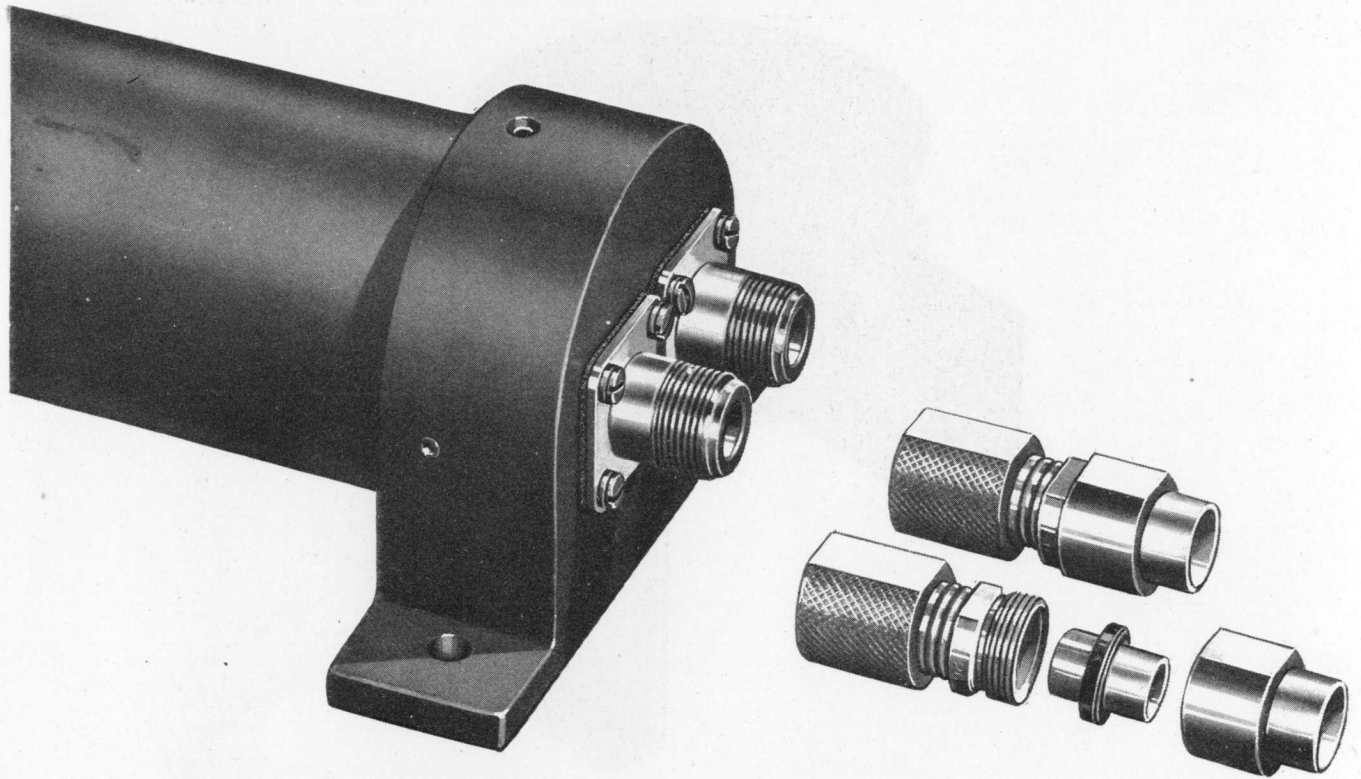

Figure 6-36. Impedance Matching Transformer CU-19/SPR-1 or CU-27/SPR-1, Upper End View.

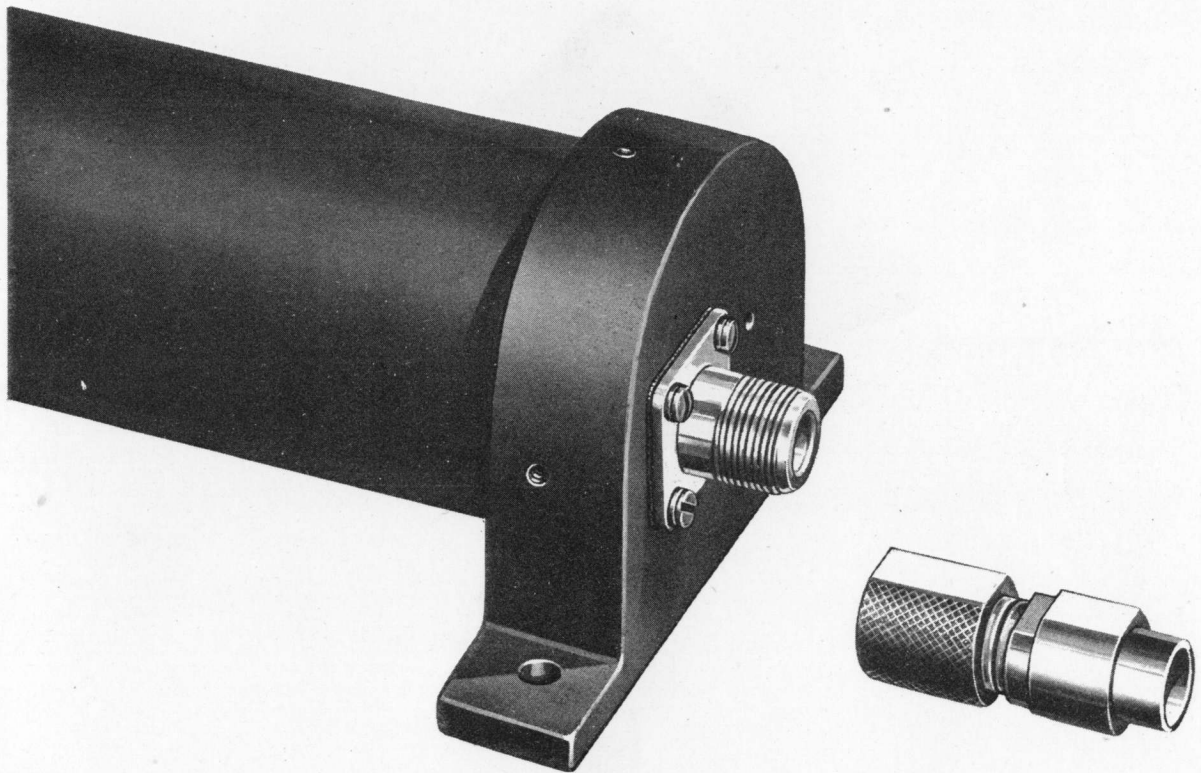

Figure 6-37. Impedance Matching Transformer CU-19/SPR-1 or CU-27/SPR-1, Low End View.

RESTRICTED  
AN-16-30APR-1-3  
NAVSHIPS 900, 483A

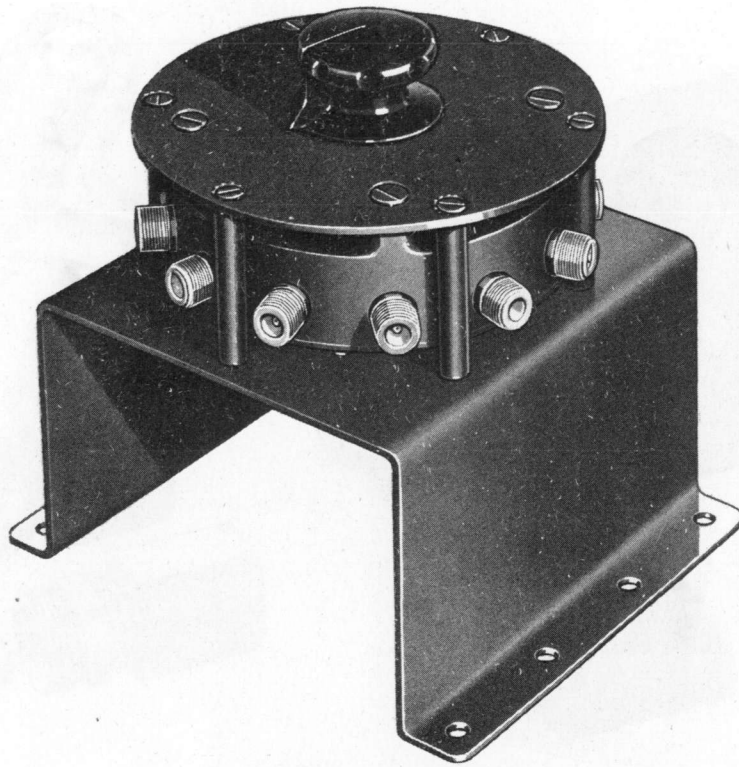

Figure 6-38. Radio Frequency Switch SA-14/SPR-1.

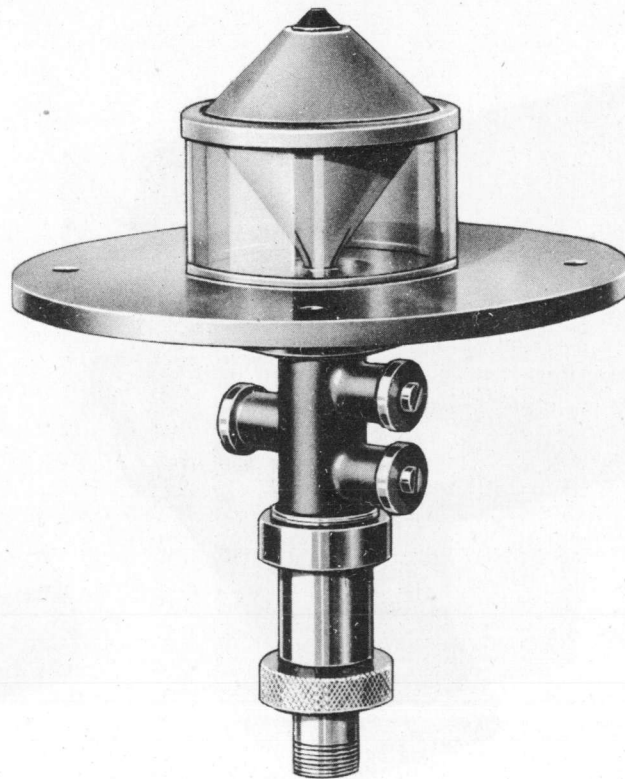

Figure 6-39. Cone Antenna AS-44/APR-5.



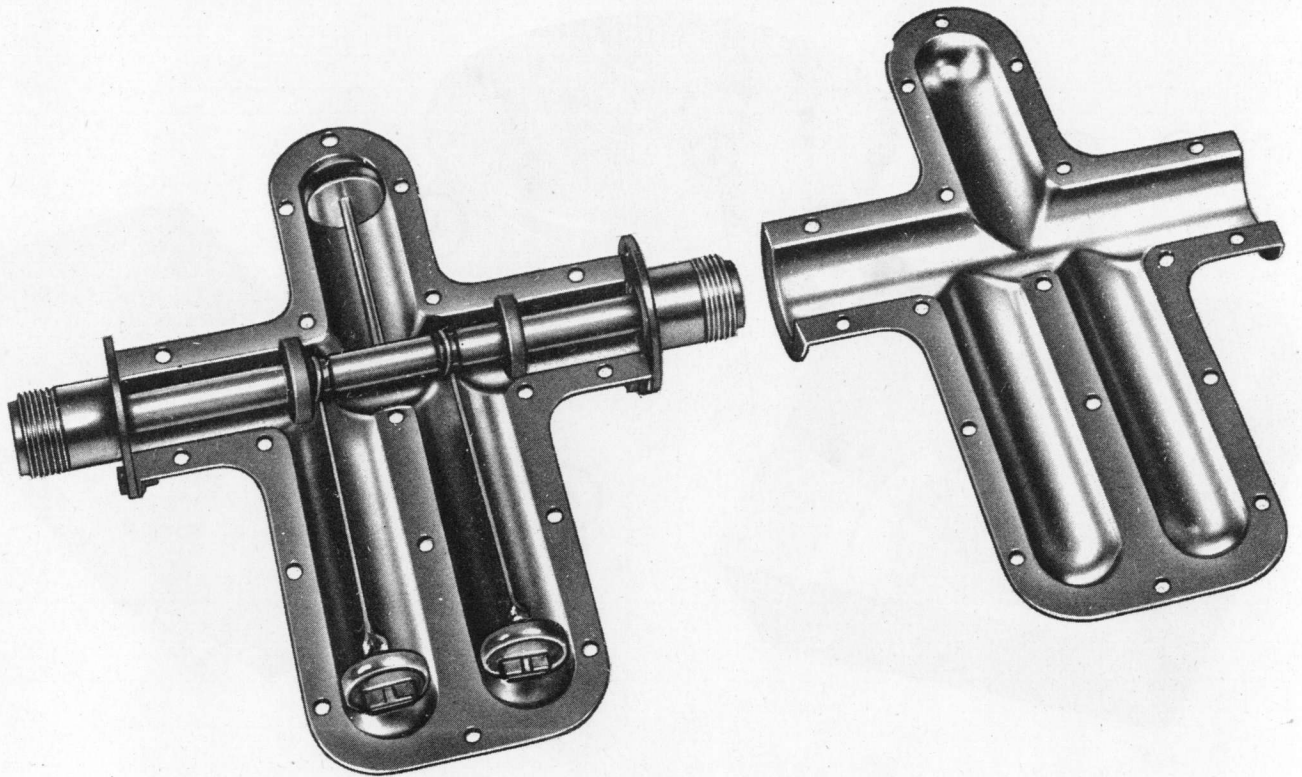

Figure 6-40. Wave Trap F-41/SPR-1, Open View.



Figure 6-41. Tuning Unit TN-4A/APR-1.

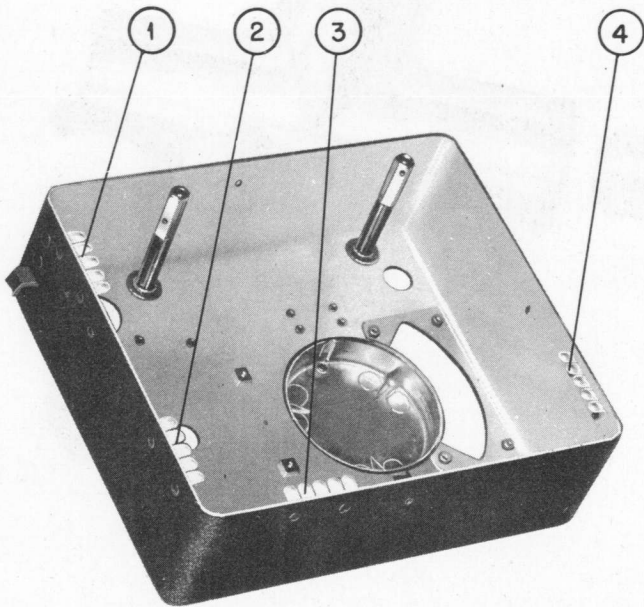

Figure 6-42. Sector Sweep Cover.

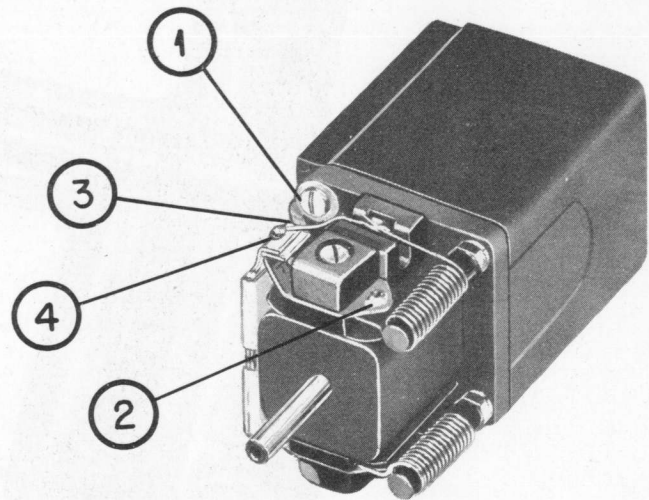

Figure 6-43. Sector Sweep Motor.

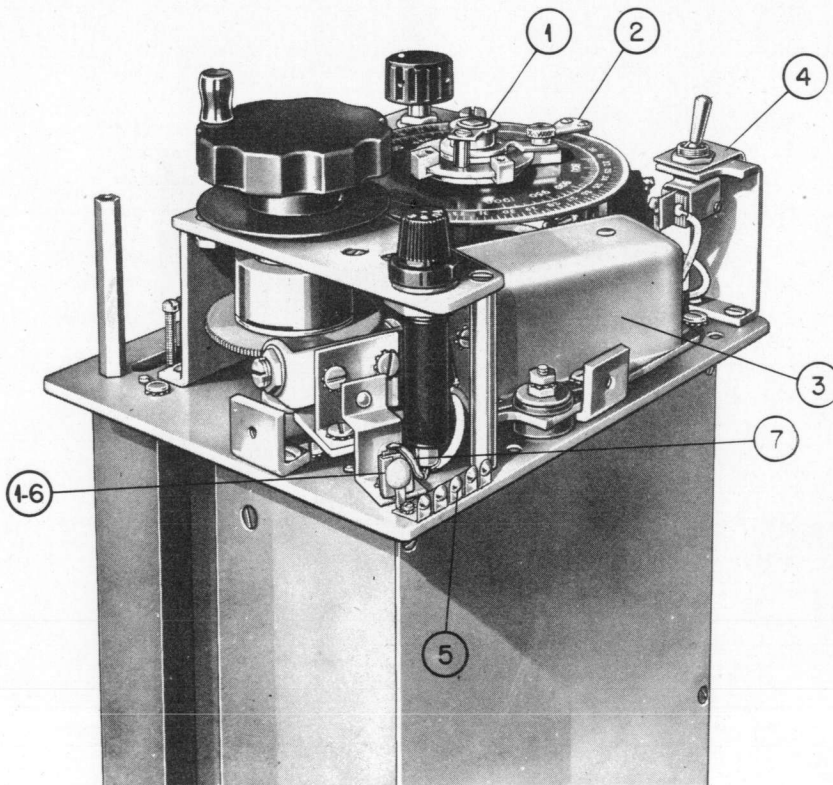

Figure 6-44. Sector Sweep, Top Panel.

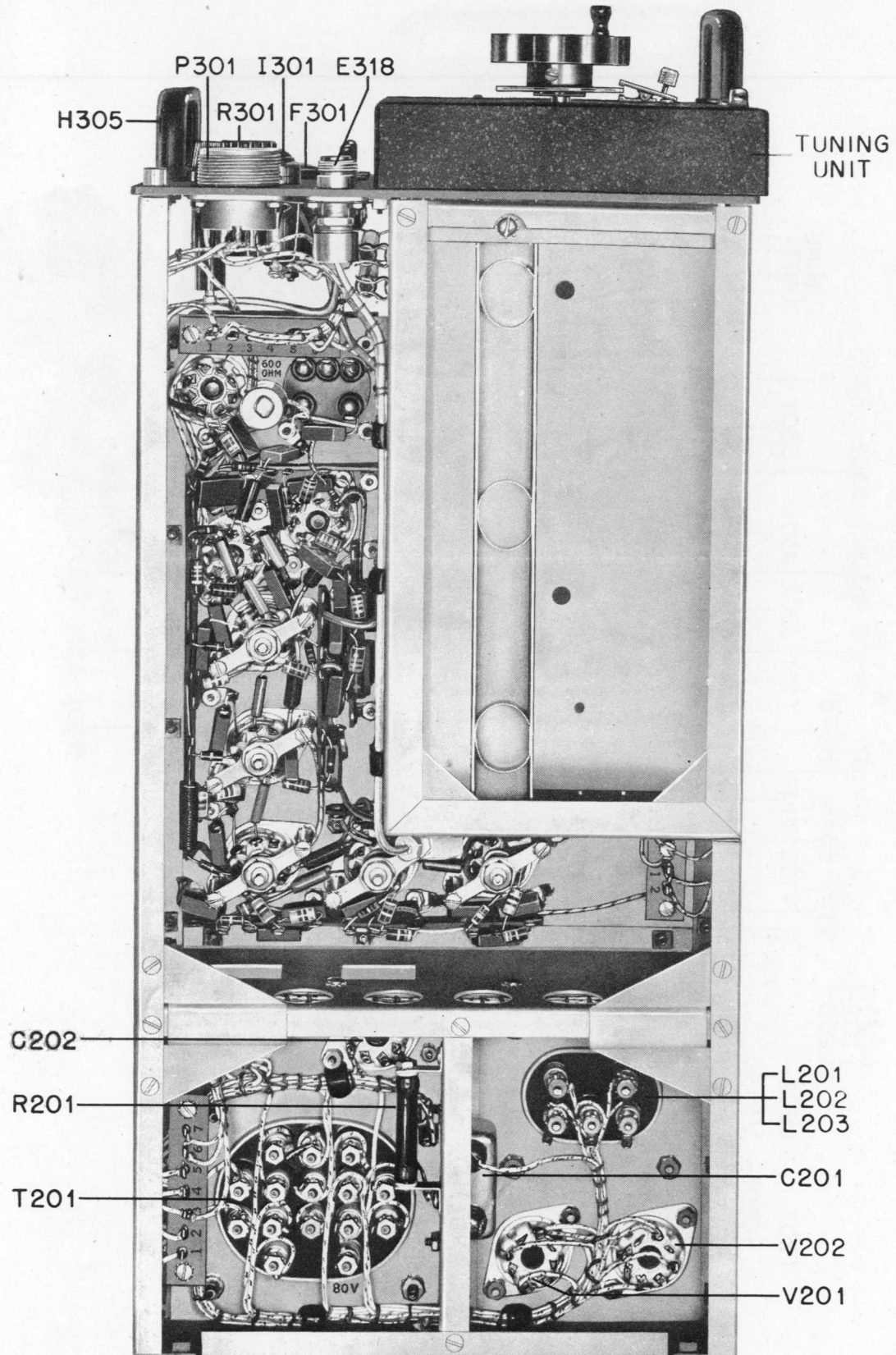

Figure 6-45. Amplifier Strip AM-12/APR-1 and Rectifier PP-10/APR-1, Bottom View.

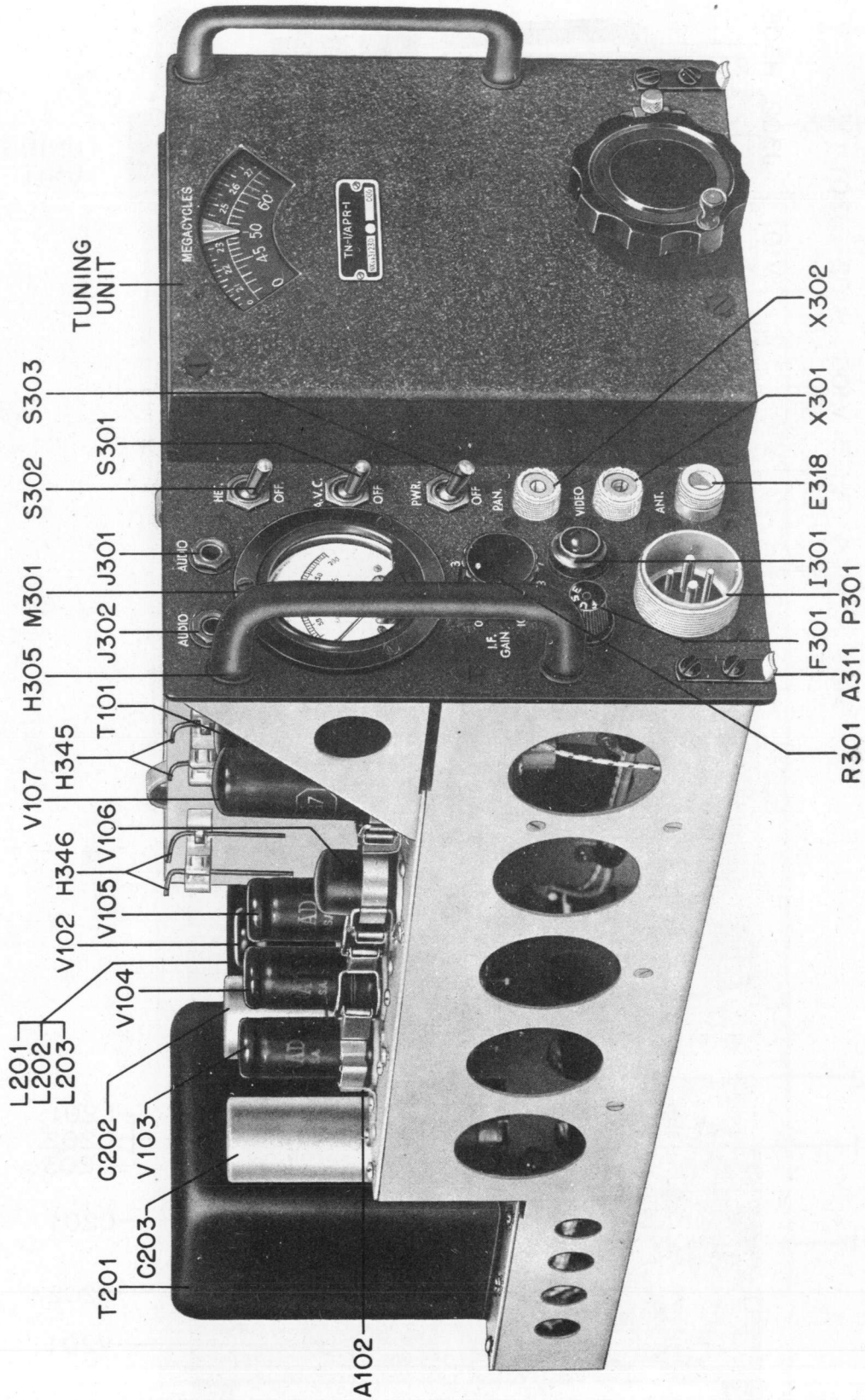

Figure 6-46. Amplifier Strip AM-12/APR-1, Rectifier PP-10/APR-1 and Tuning Unit, Left Front Oblique View.

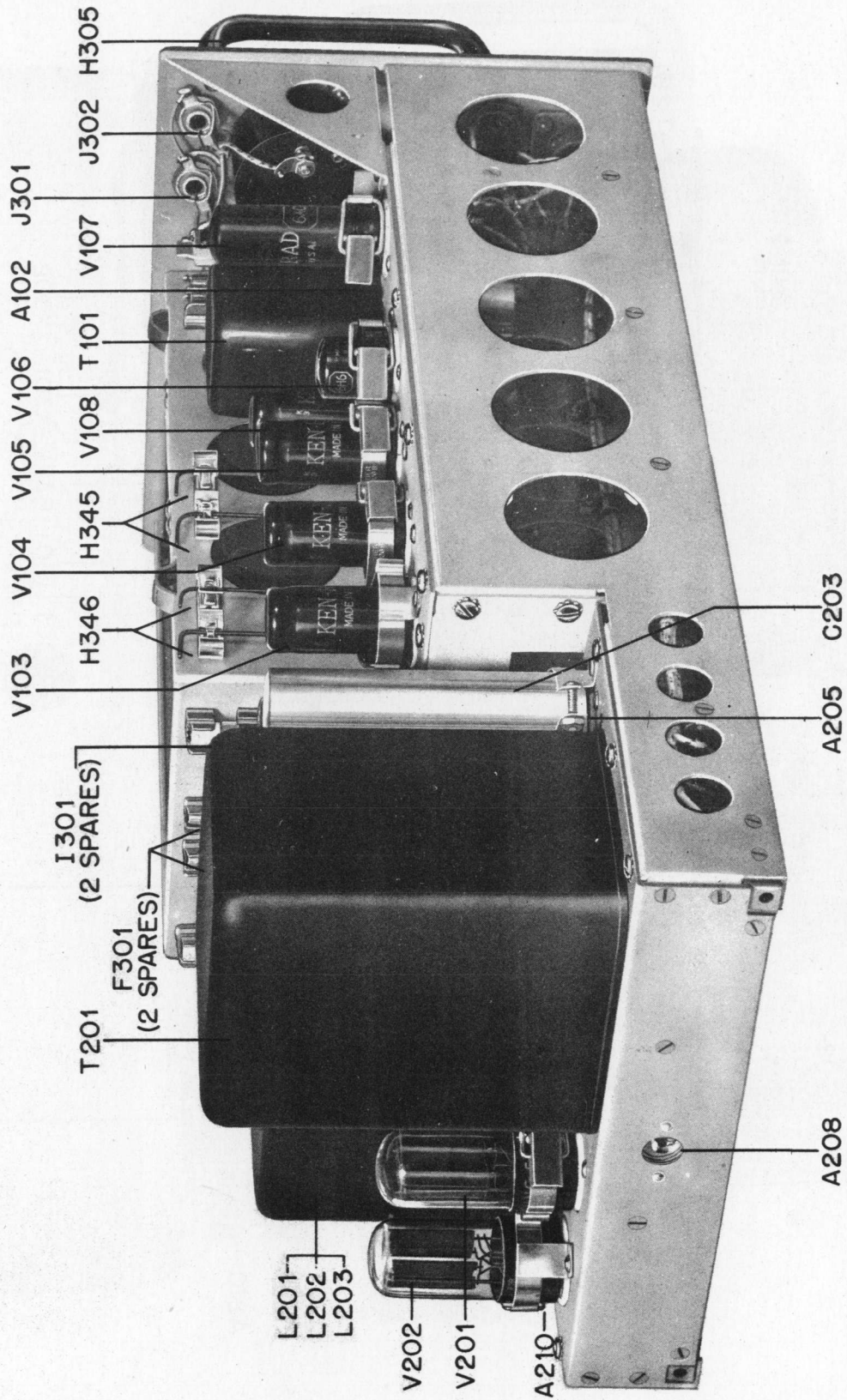

Figure 6-47. Amplifier Strip AM-12/APR-1 and Rectifier PP-10/APR-1, Rear Right Oblique View.

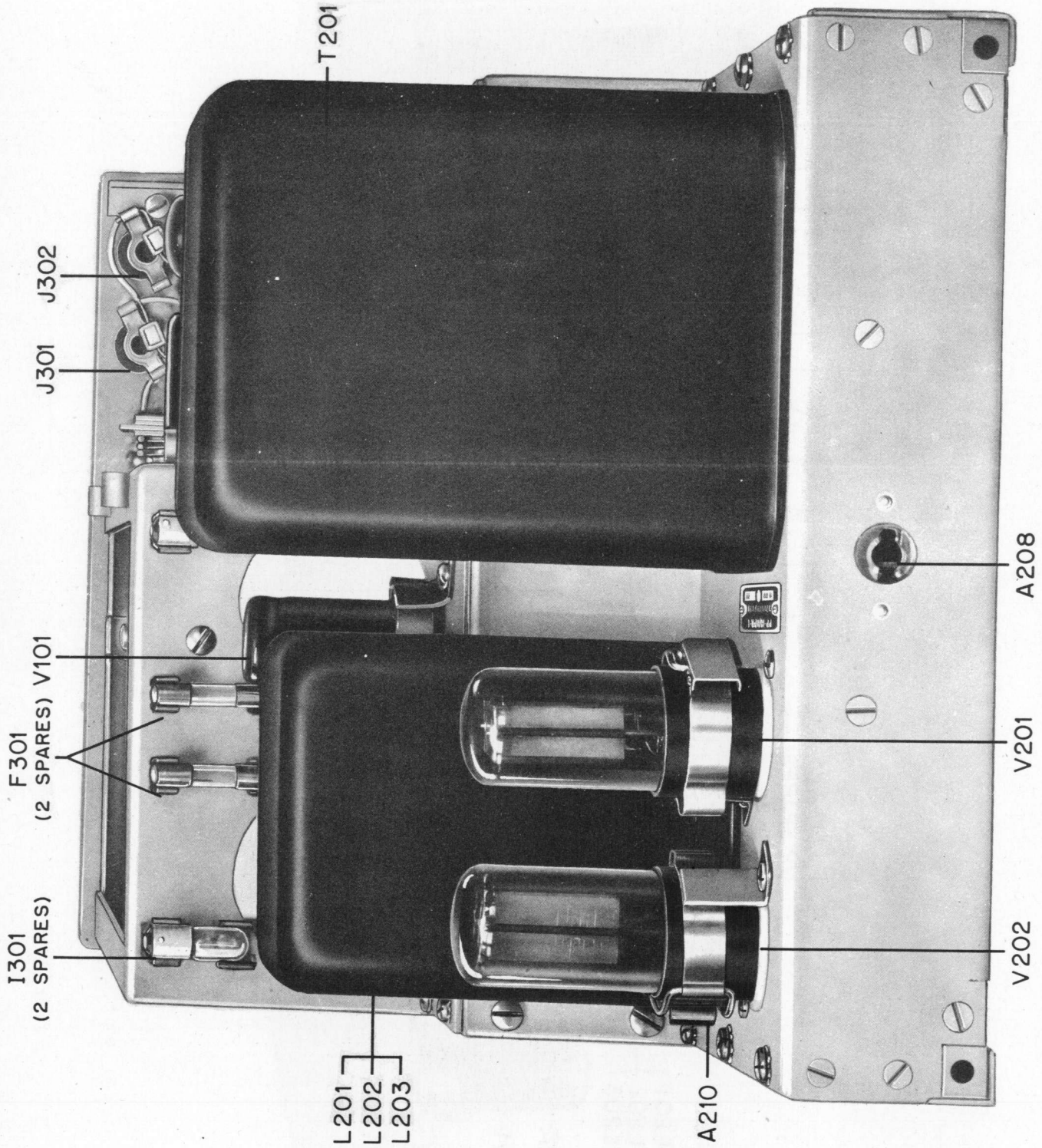

Figure 6-48. Amplifier Strip AM-12/APR-1 and Rectifier PP-10/APR-1 Rear View.

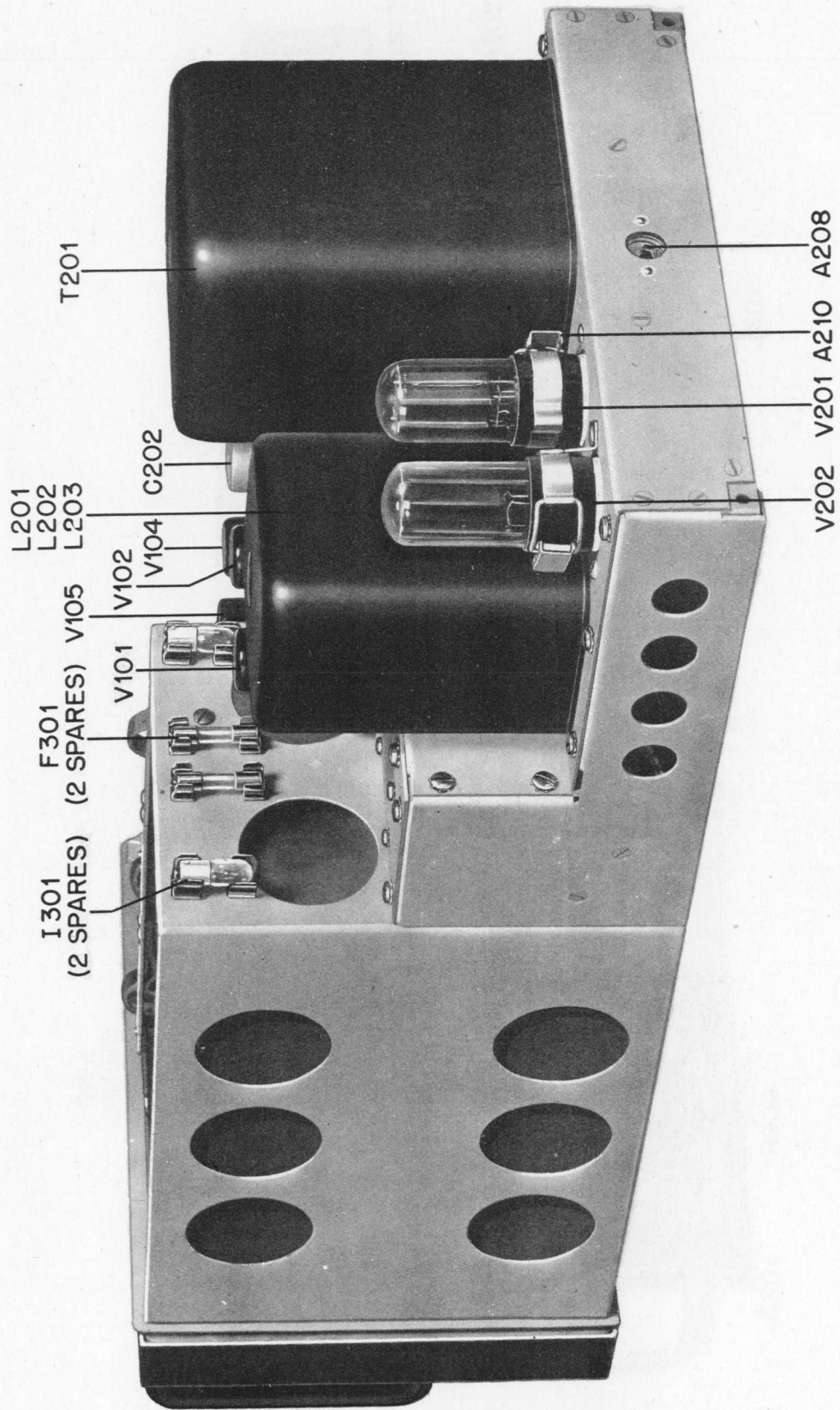

Figure 6-49. Amplifier Strip AM-12/APR-1 and Rectifier PP-10/APR-1, Rear Left Oblique View.

RESTRICTED  
AN-16-30APR-1-3  
NAVSHIPS 900, 483A

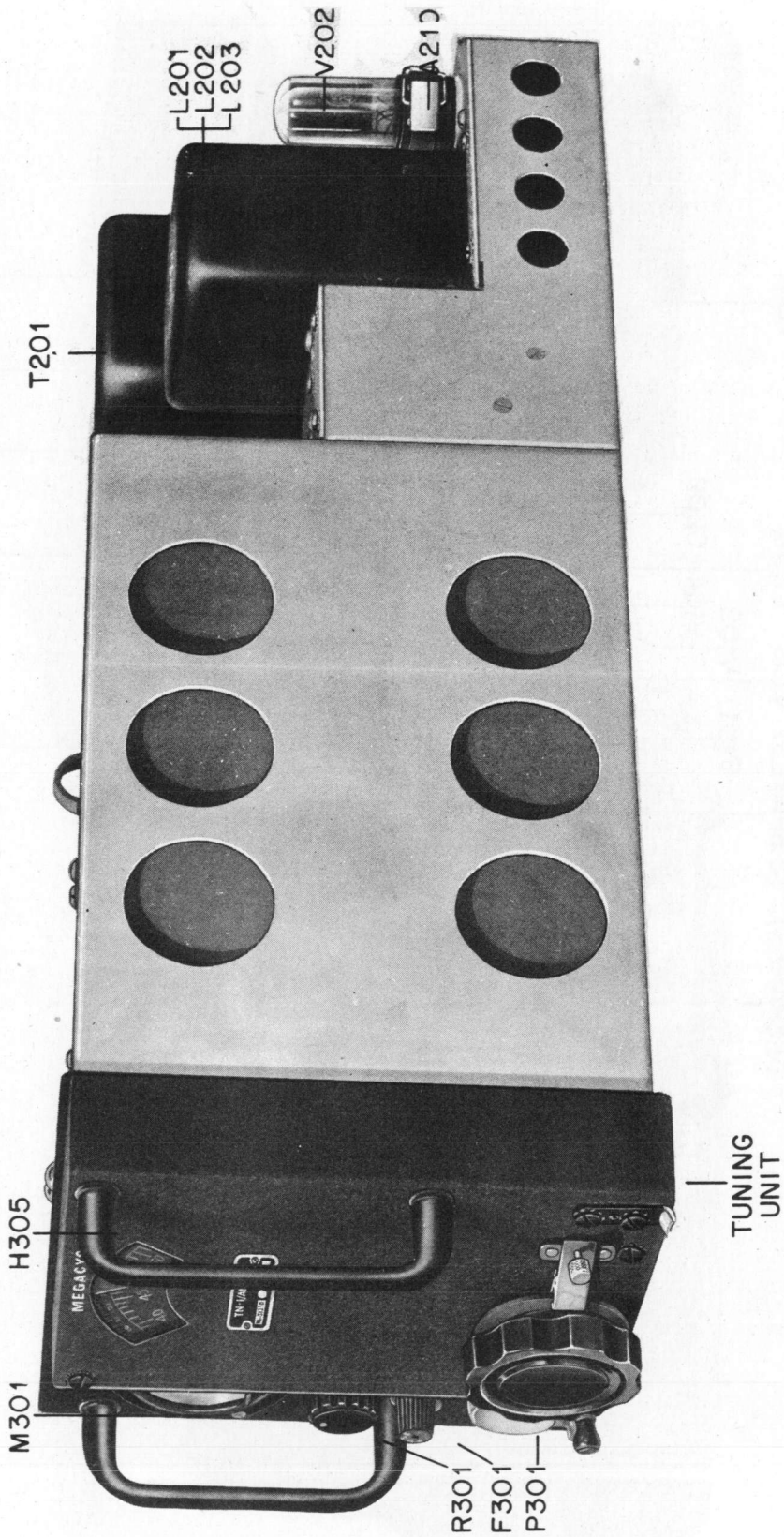

Figure 6-50. Amplifier Strip AM-12/APR-1, Rectifier PP-10/APR-1, and Tuning Unit, Right Front Oblique View.



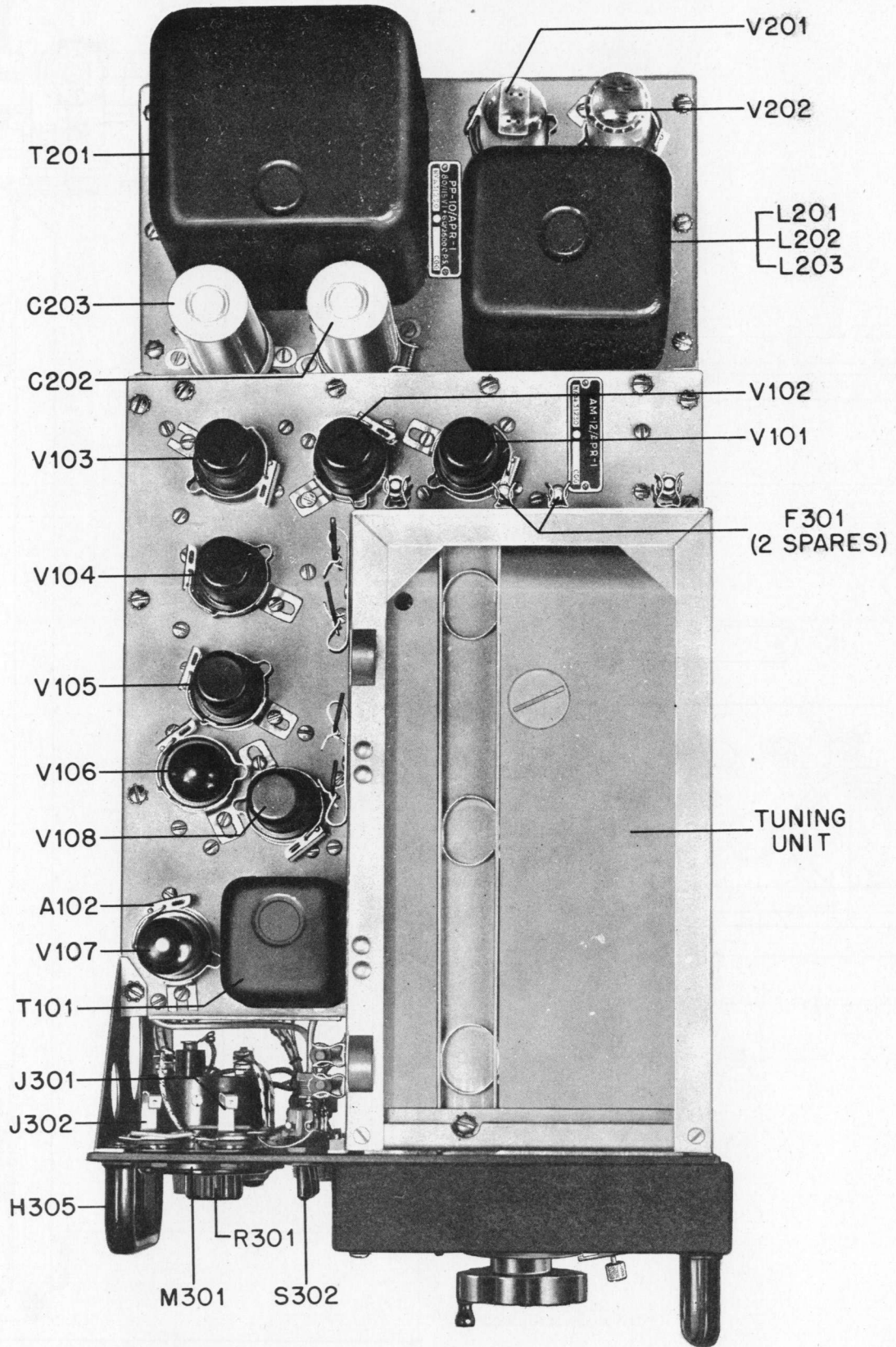

Figure 6-51. Amplifier Strip AM-12/APR-1, Rectifier PP-10/APR-1 and Tuning Unit, Top View.

**RESTRICTED**  
**AN-16-30APR-1-3**  
**NAVSHIPS 900, 483A**

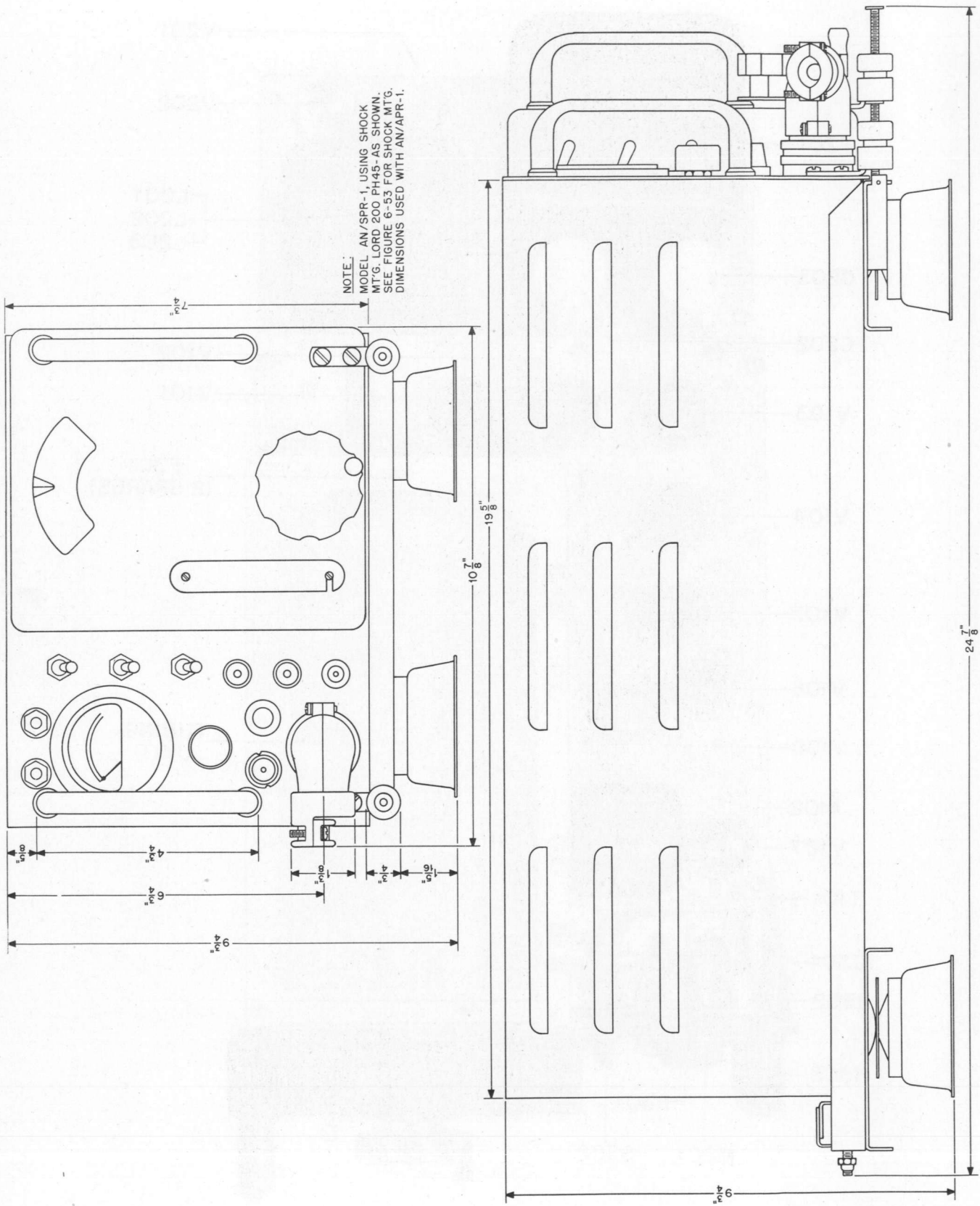

Figure 6-52. Radio Receiving Equipment AN/APR-1 and AN/SPR-1, Overall Dimensional.

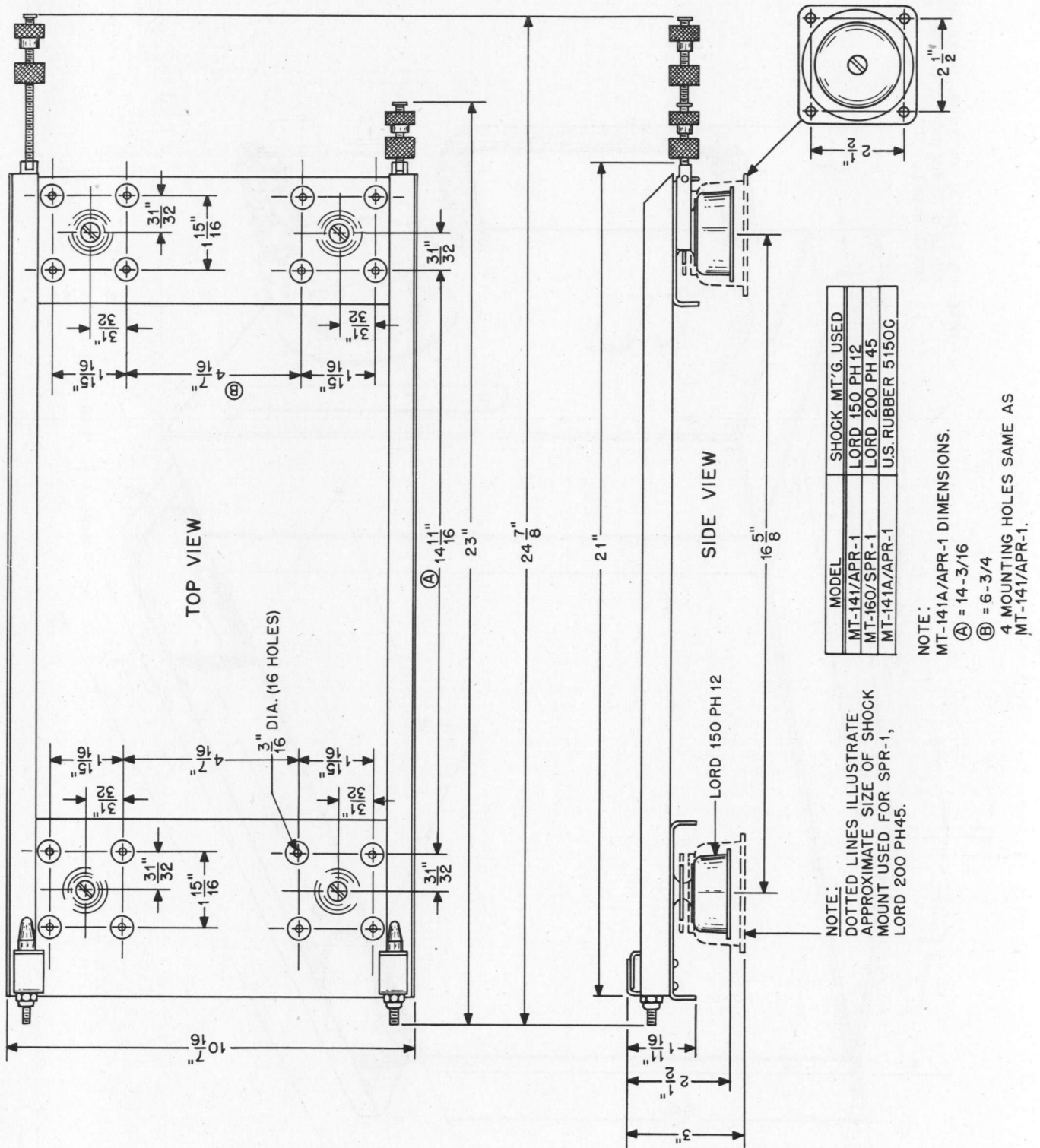

Figure 6-53. Mounting MT-141/APR-1 and MT-160/SPR-1 Outline Dimensional and Hole Location Detail.

NOTE: DIMENSION (A) FOR TN-1B, TN-2B AND TN-3B IS 2-3/8 INCHES. (SECTOR SWEEP MODEL ONLY.)

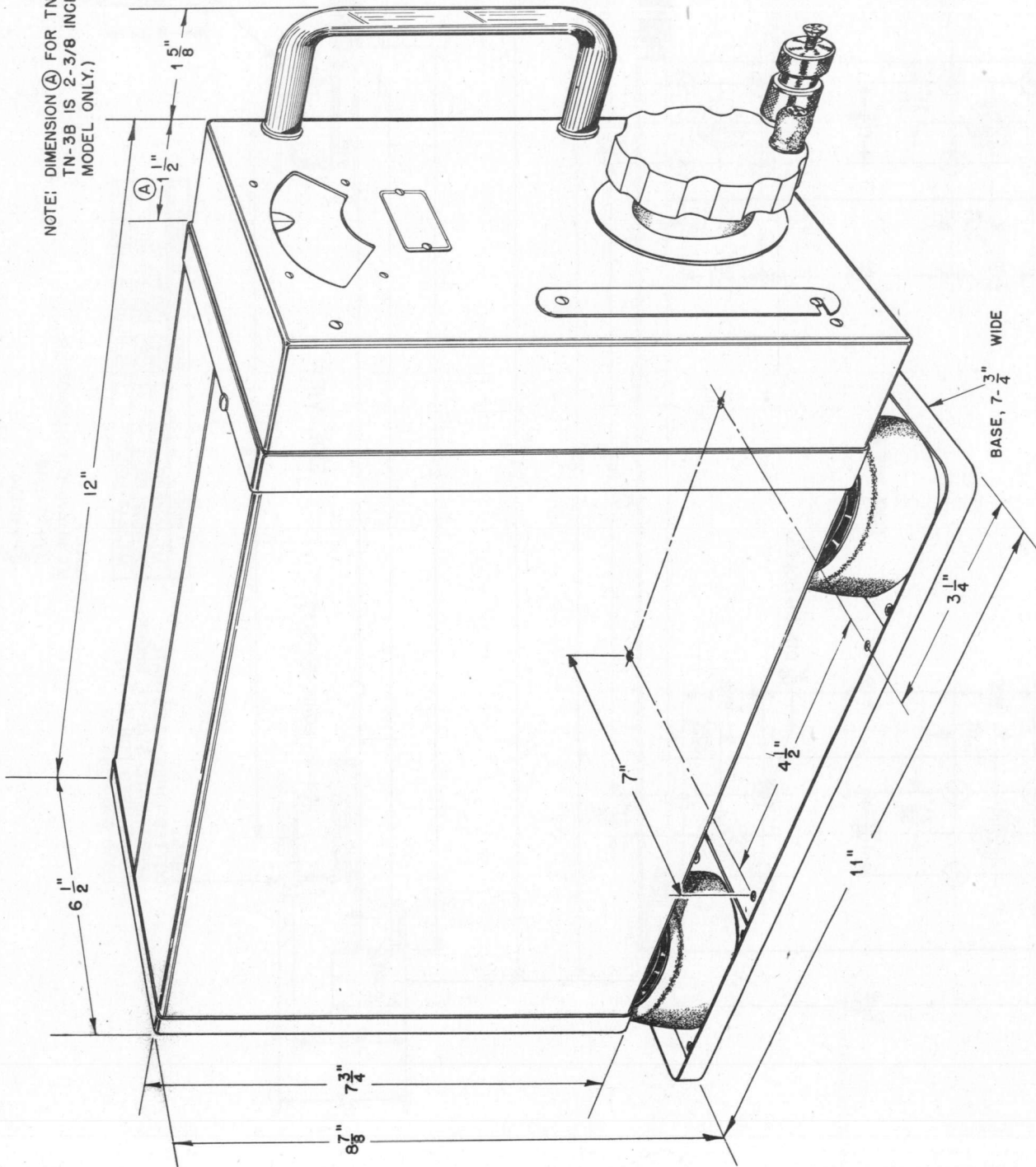

Figure 6-54. Carrying Case CY-57/APR-1 with Tuning Unit, Outline Dimensional.

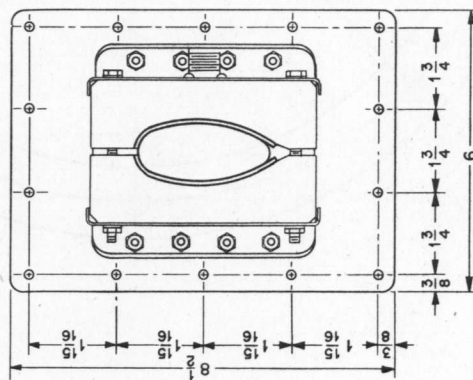
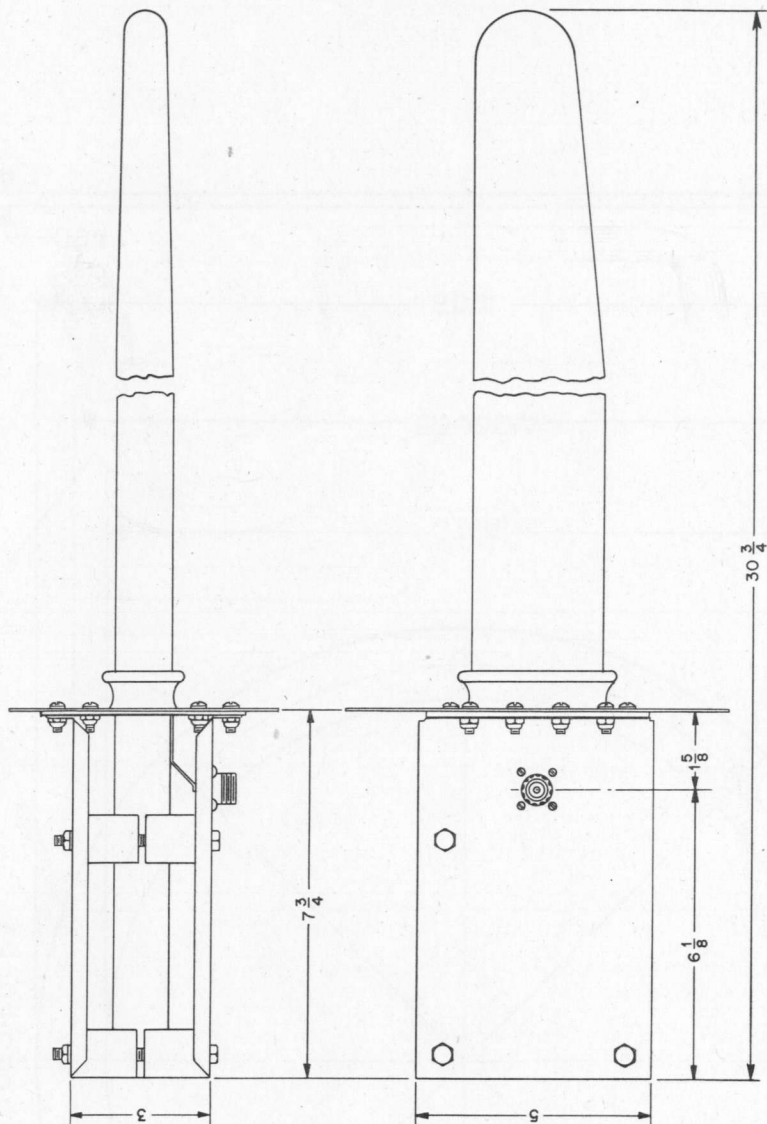

Figure 6-55. Antenna AT-37/APT, Outline Dimensional.

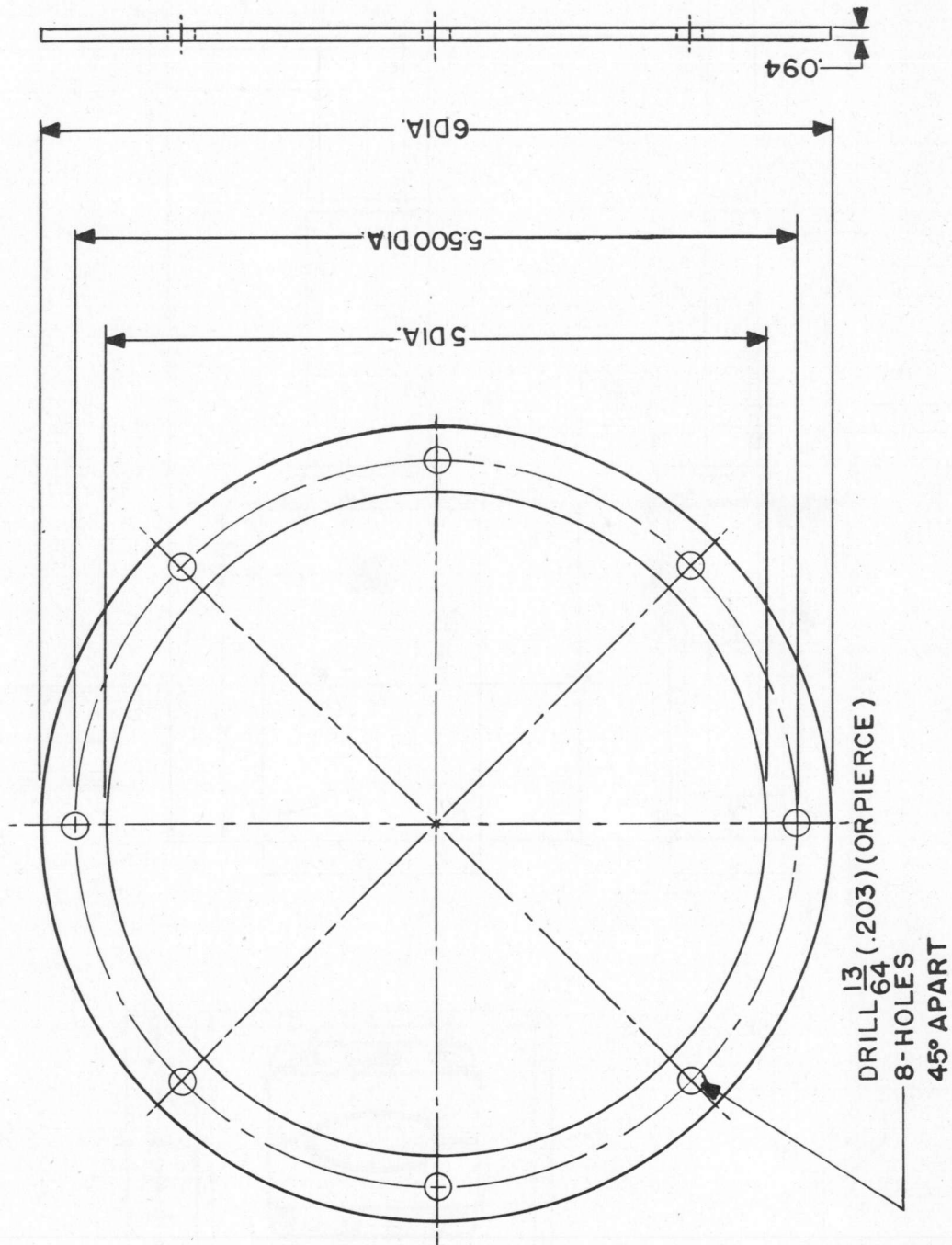

Figure 6-56. Ring Cone Mounting.

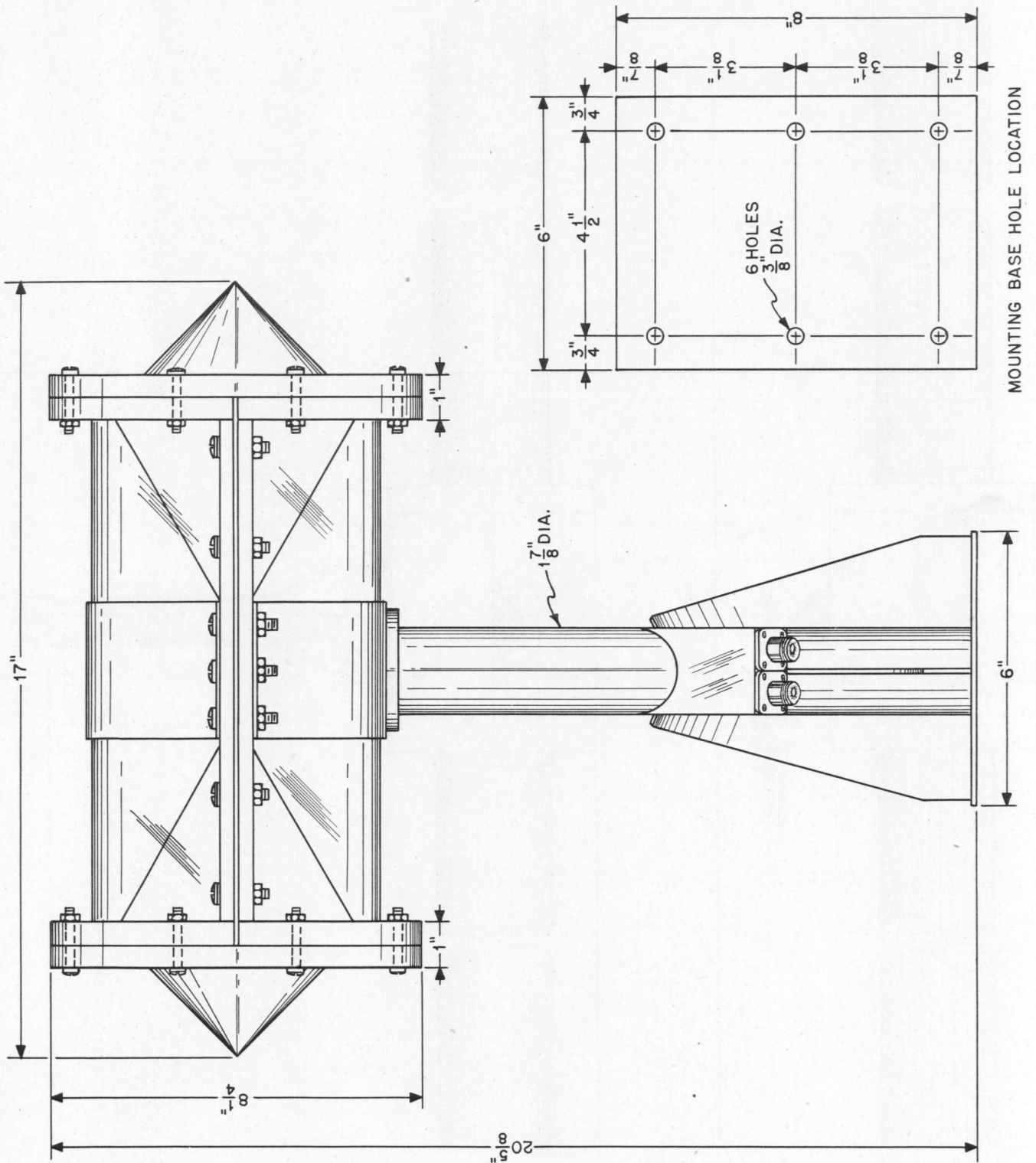

Figure 6-57. Double Cone Antenna AS-57/SPR-1, Outline Dimensional.

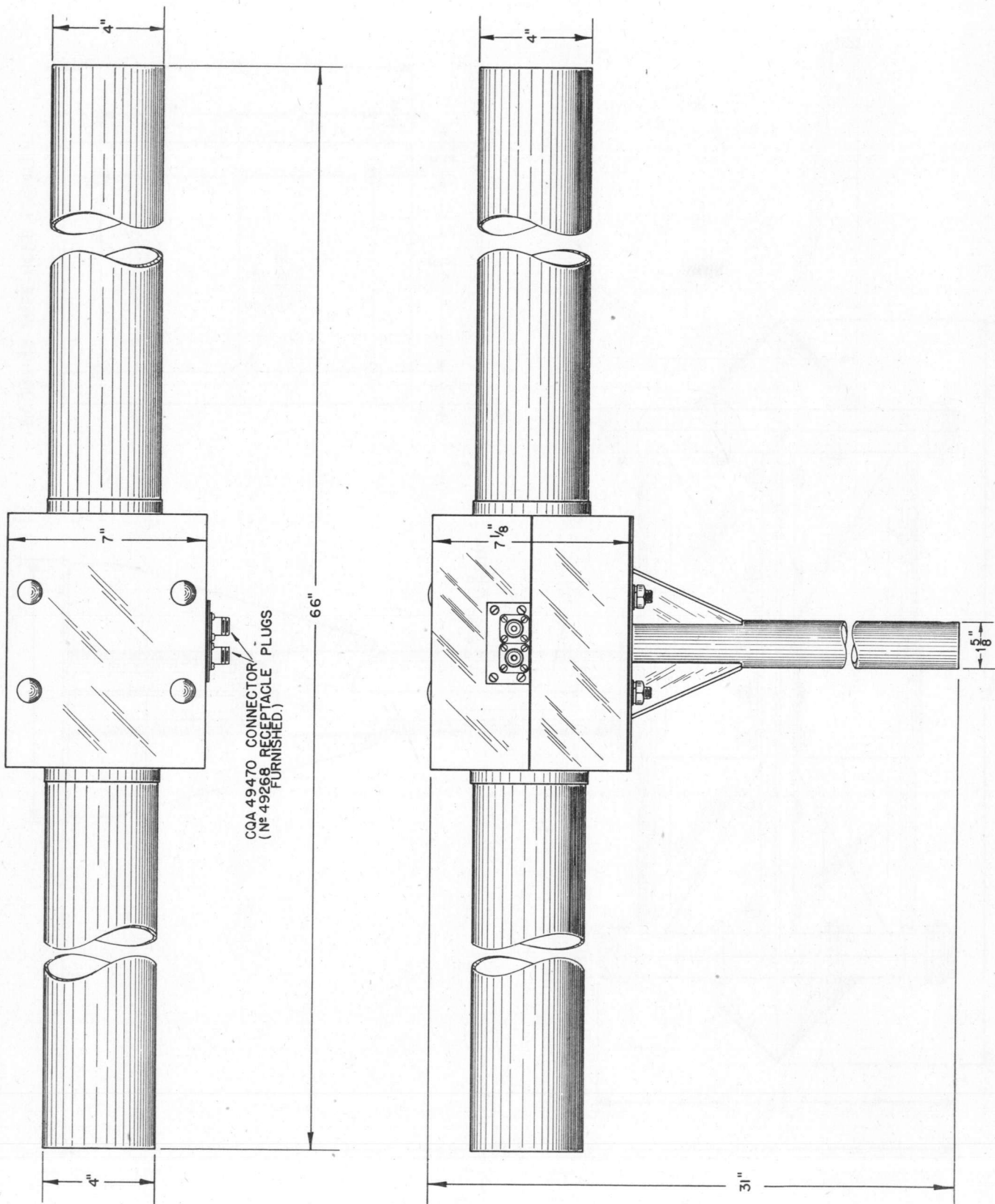

Figure 6-58. Dipole Antenna AS-56/SPR-1, Outline Dimensional.



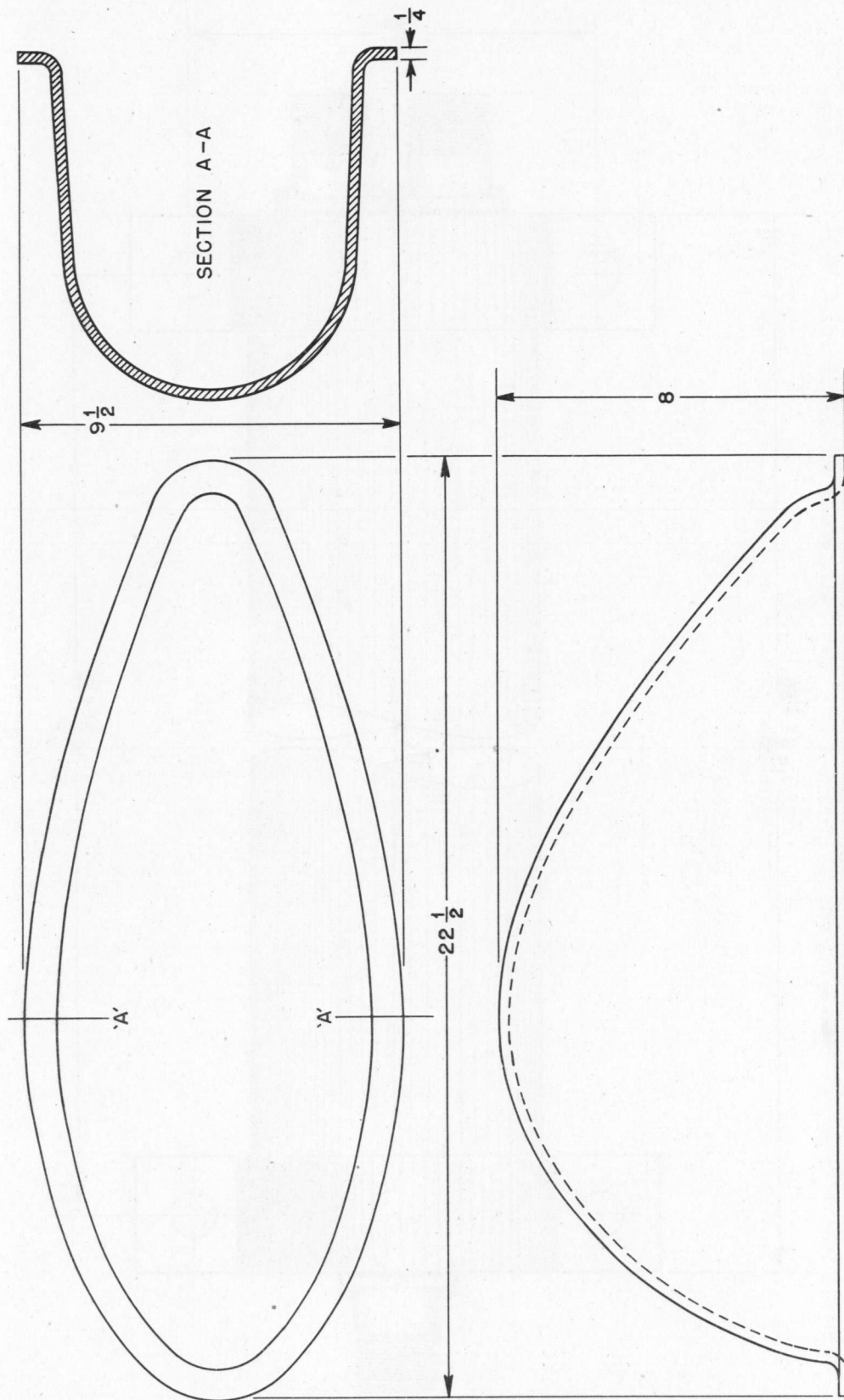

Figure 6-59. Nacelle CW-3/AP, Outline Dimensional.

RESTRICTED  
AN-16-30APR-1-3  
NAVSHIPS 900, 483A

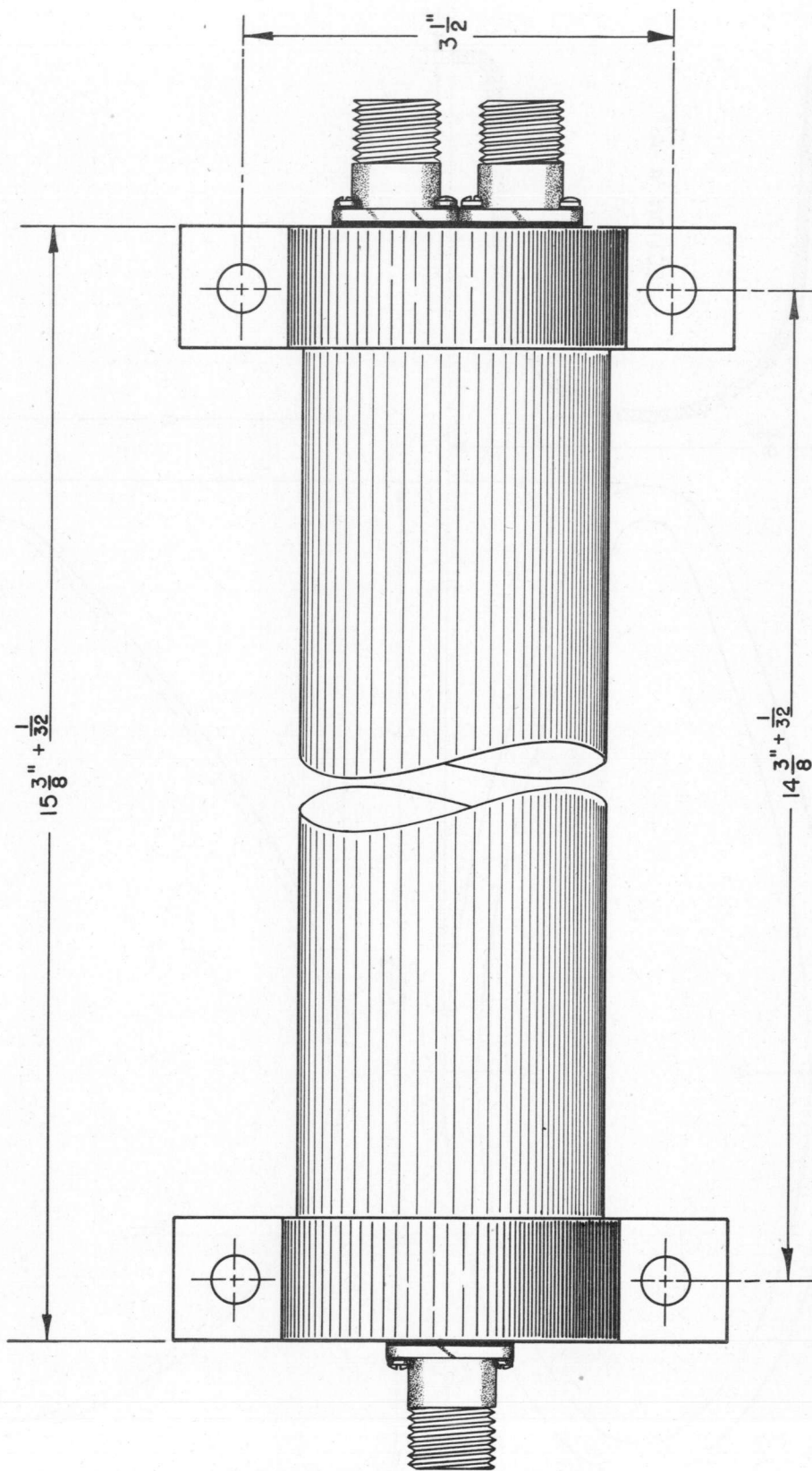

Figure 6-60. Impedance Matching Transformer CU-27/SPR-1, Outline Dimensional.

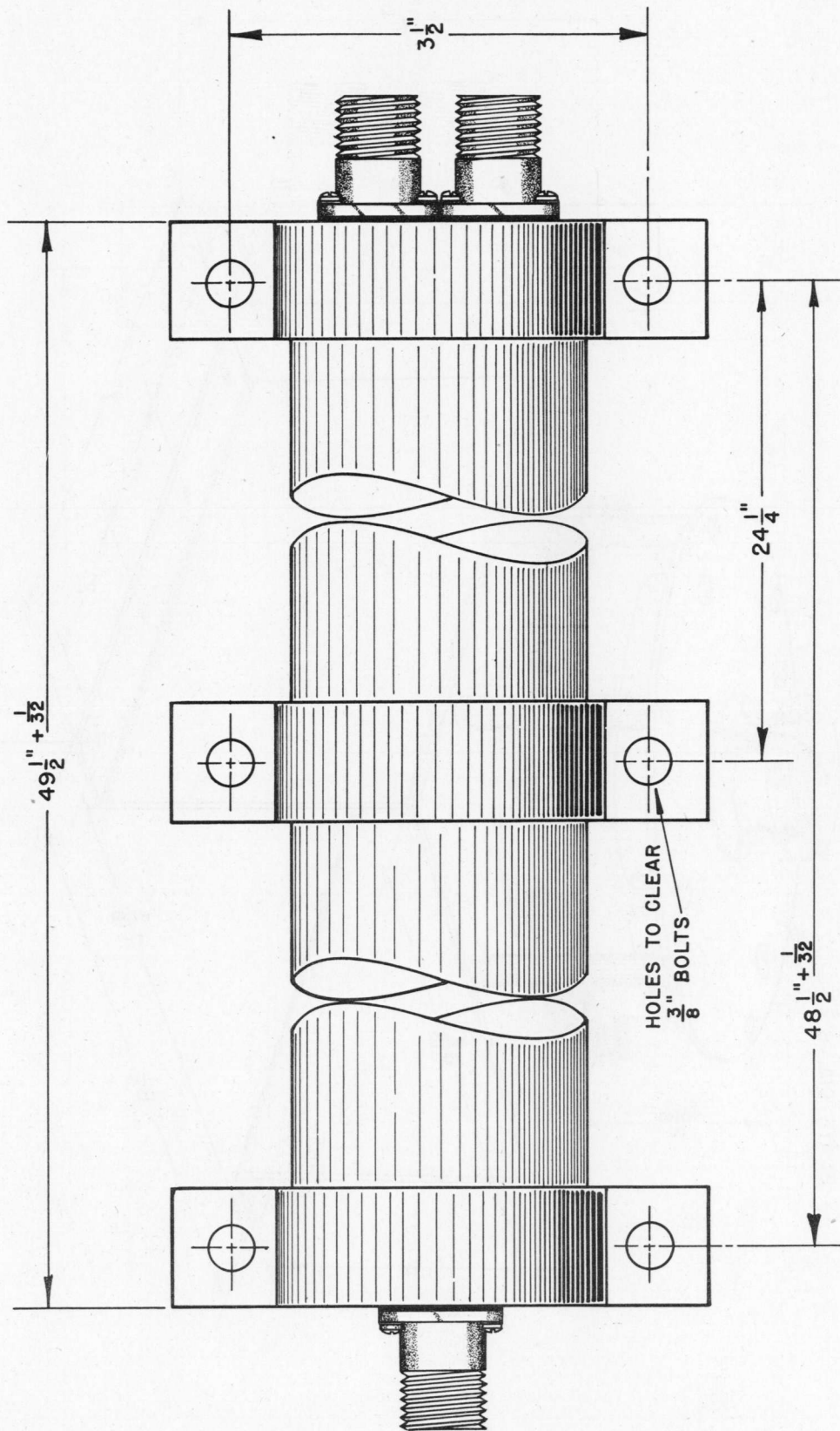

Figure 6-61. Impedance Matching Transformer CU-19/SPR-1, Outline Dimensional.

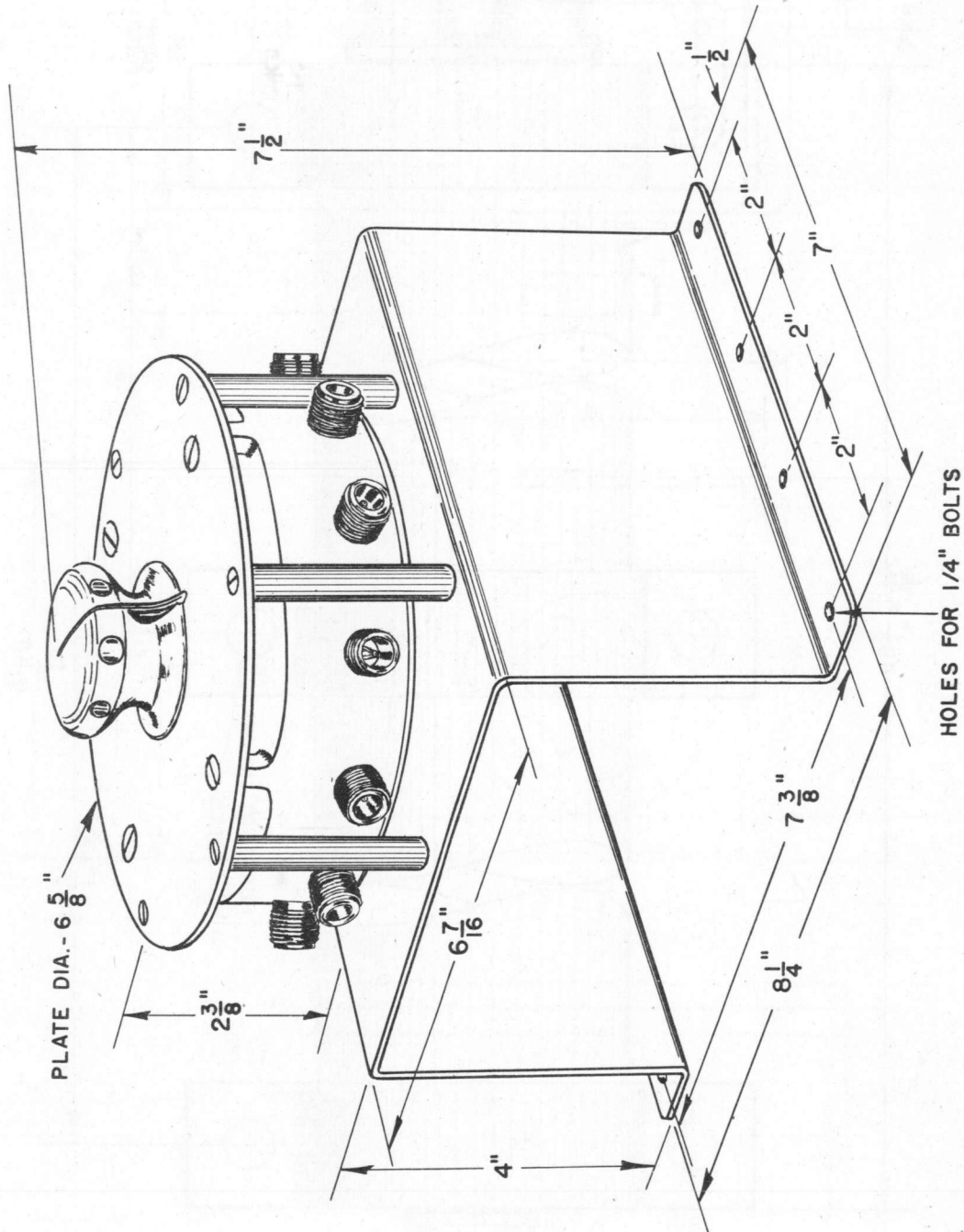

Figure 6-62. Frequency Switch SA-14/SPR-1, Outline Dimensional.

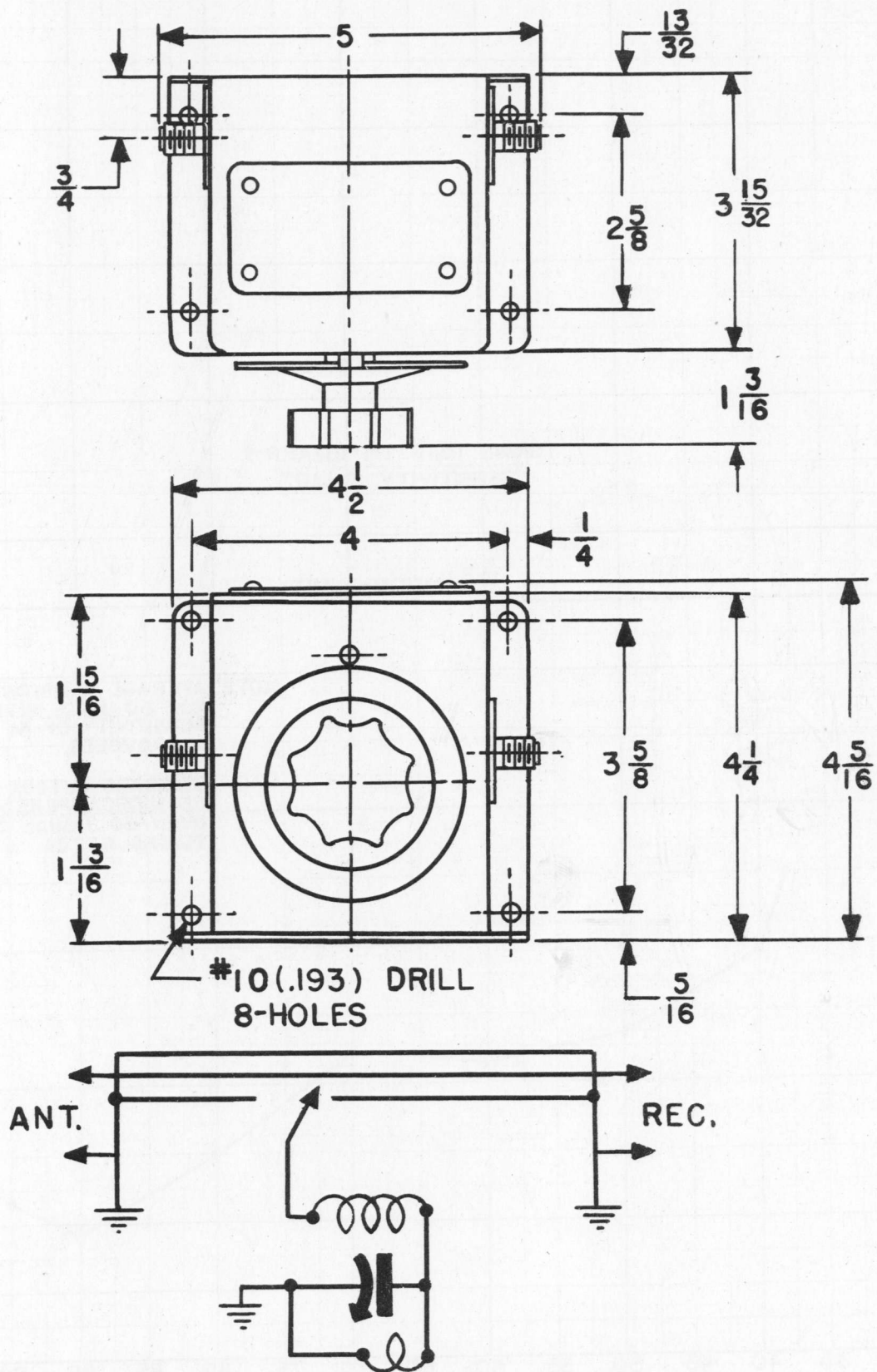

Figure 6-63. Wave Trap F-19/UPR, Outline Dimensional and Schematic.

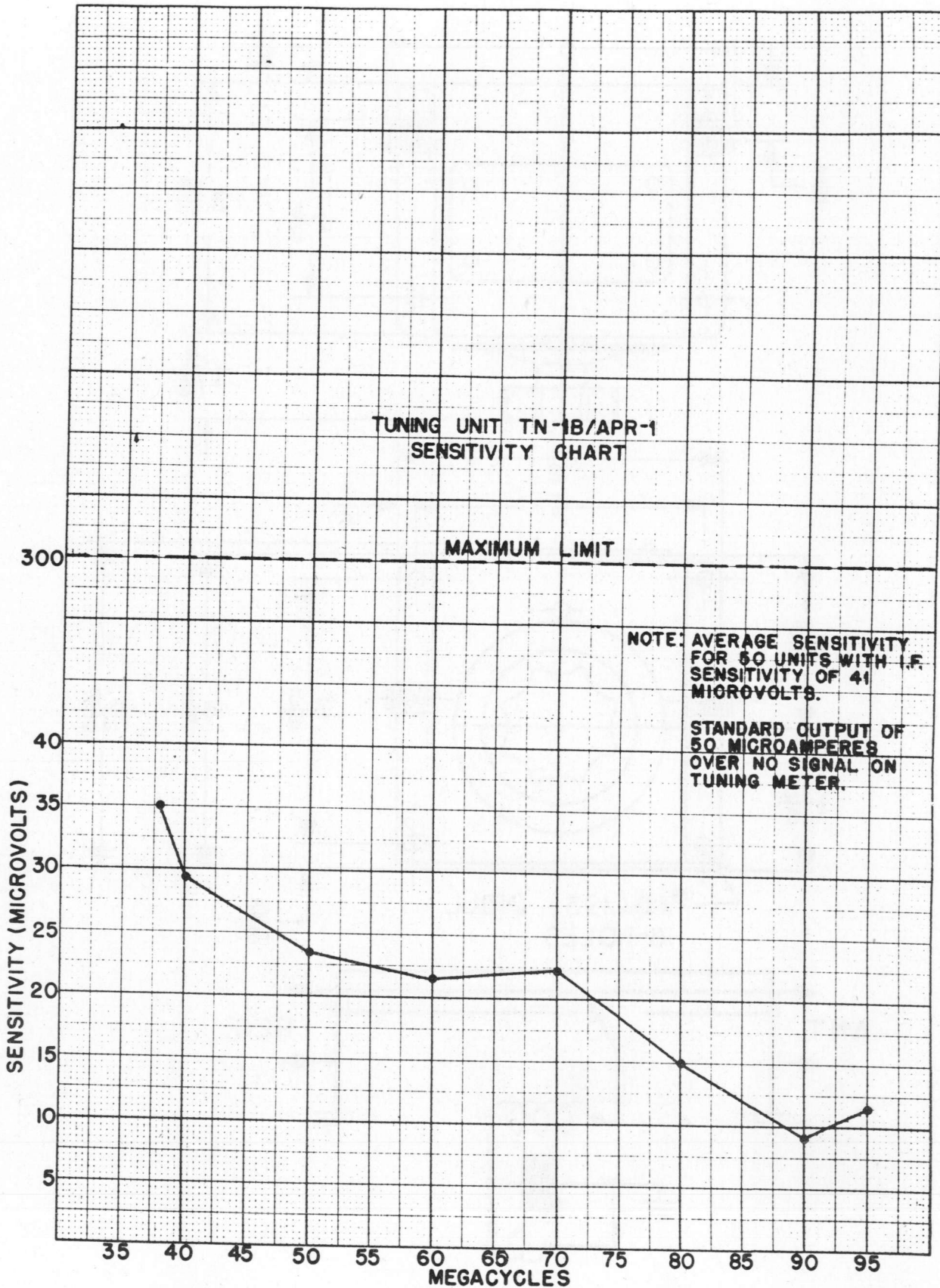

Figure 6-64. Tuning Unit TN-1B/APR-1, Sensitivity Chart.

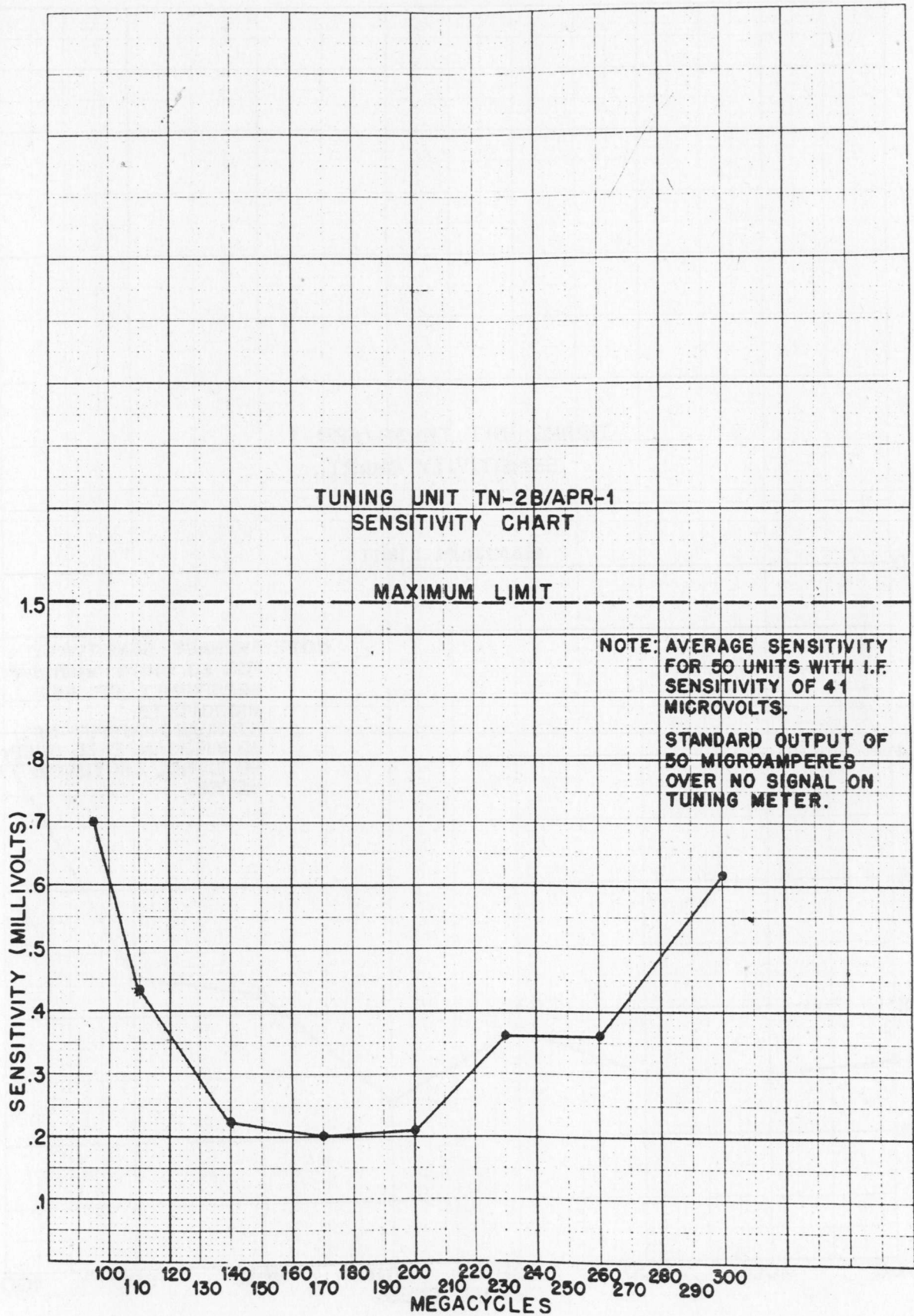

Figure 6-65. Tuning Unit TN-2B/APR-1 Sensitivity Chart.

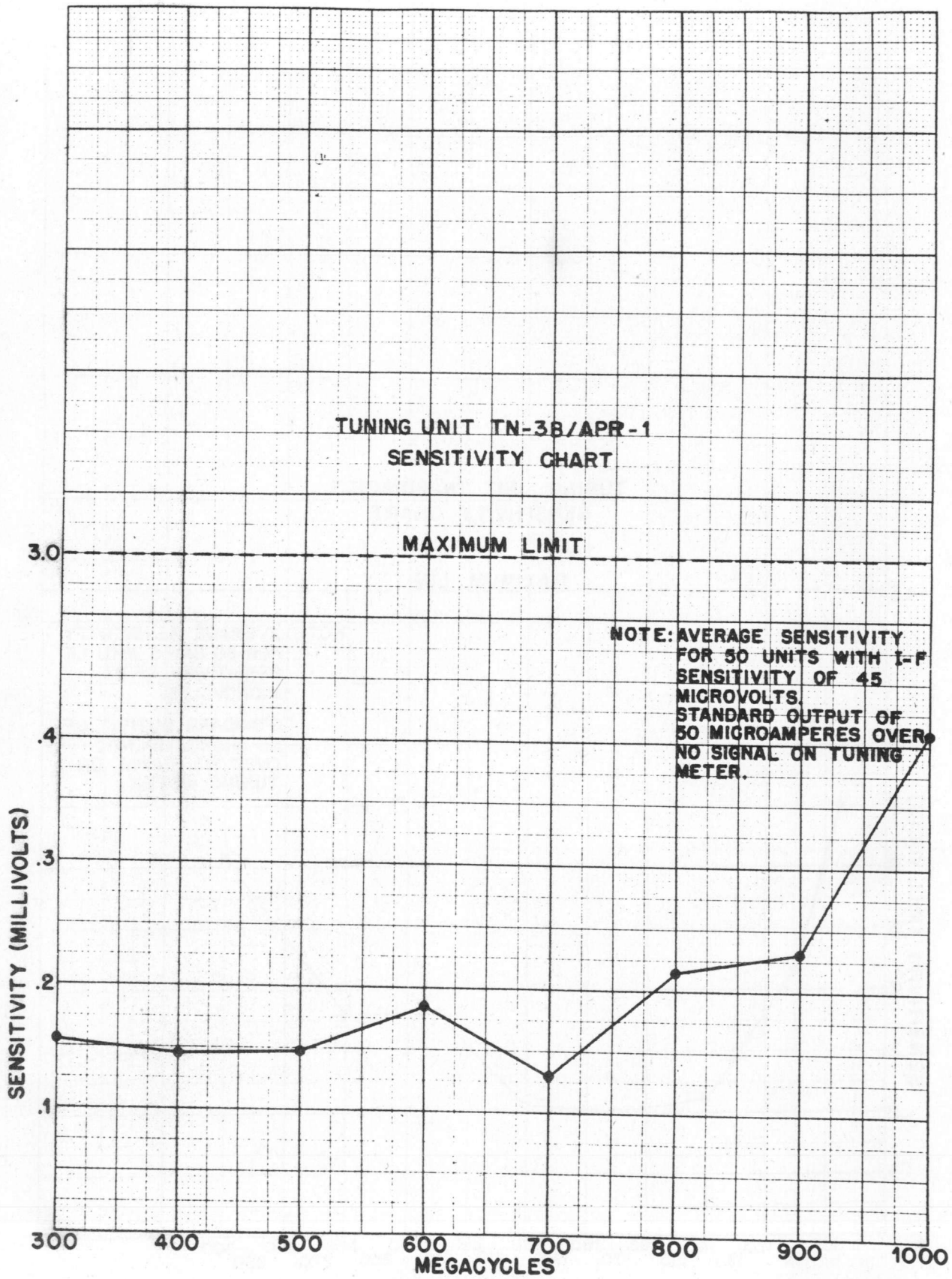

Figure 6-66. Tuning Unit TN-3B/APR-1 Sensitivity Chart.



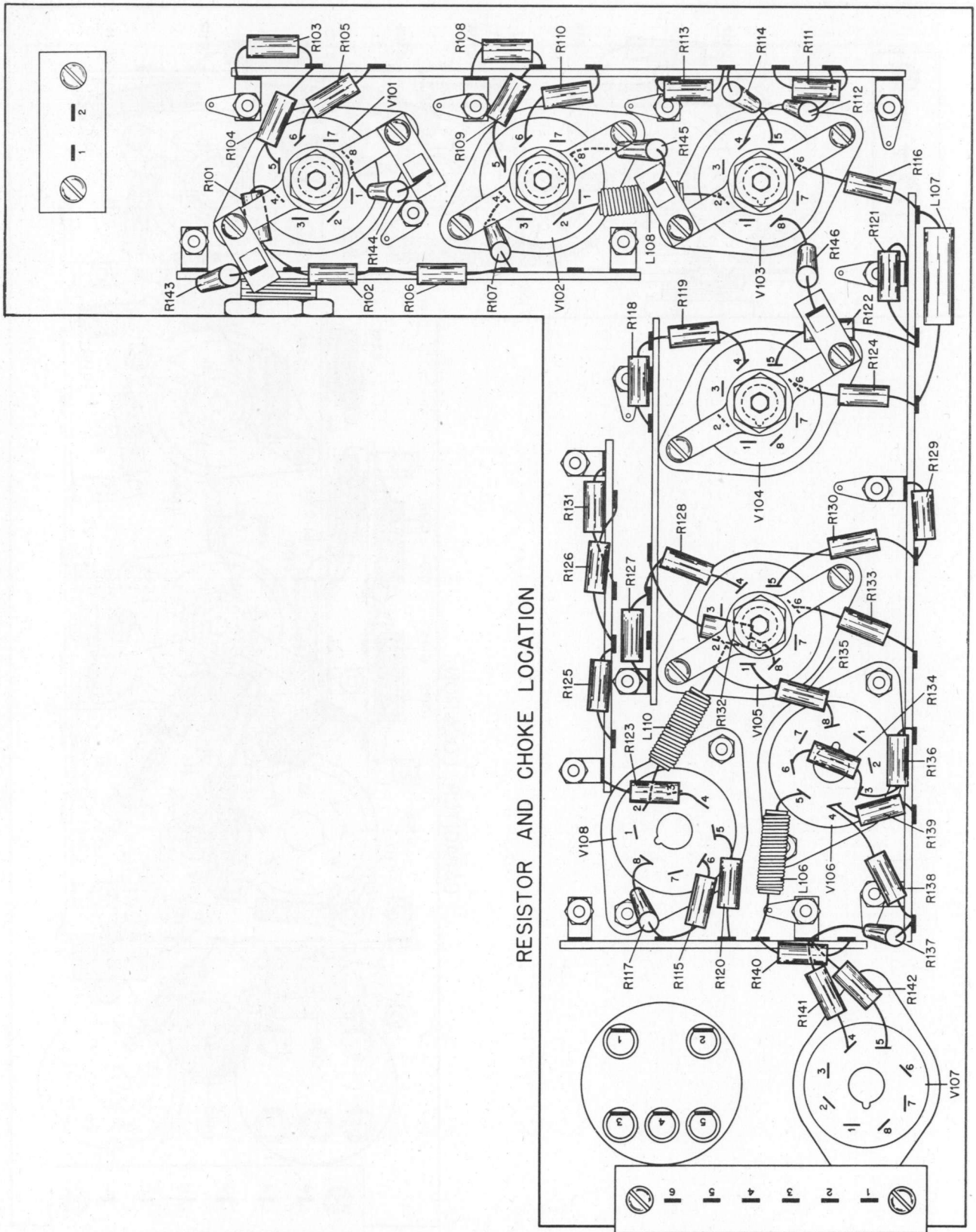

Figure 6-67. Amplifier Strip AM-12/APR-1, Resistor and Choke Location.

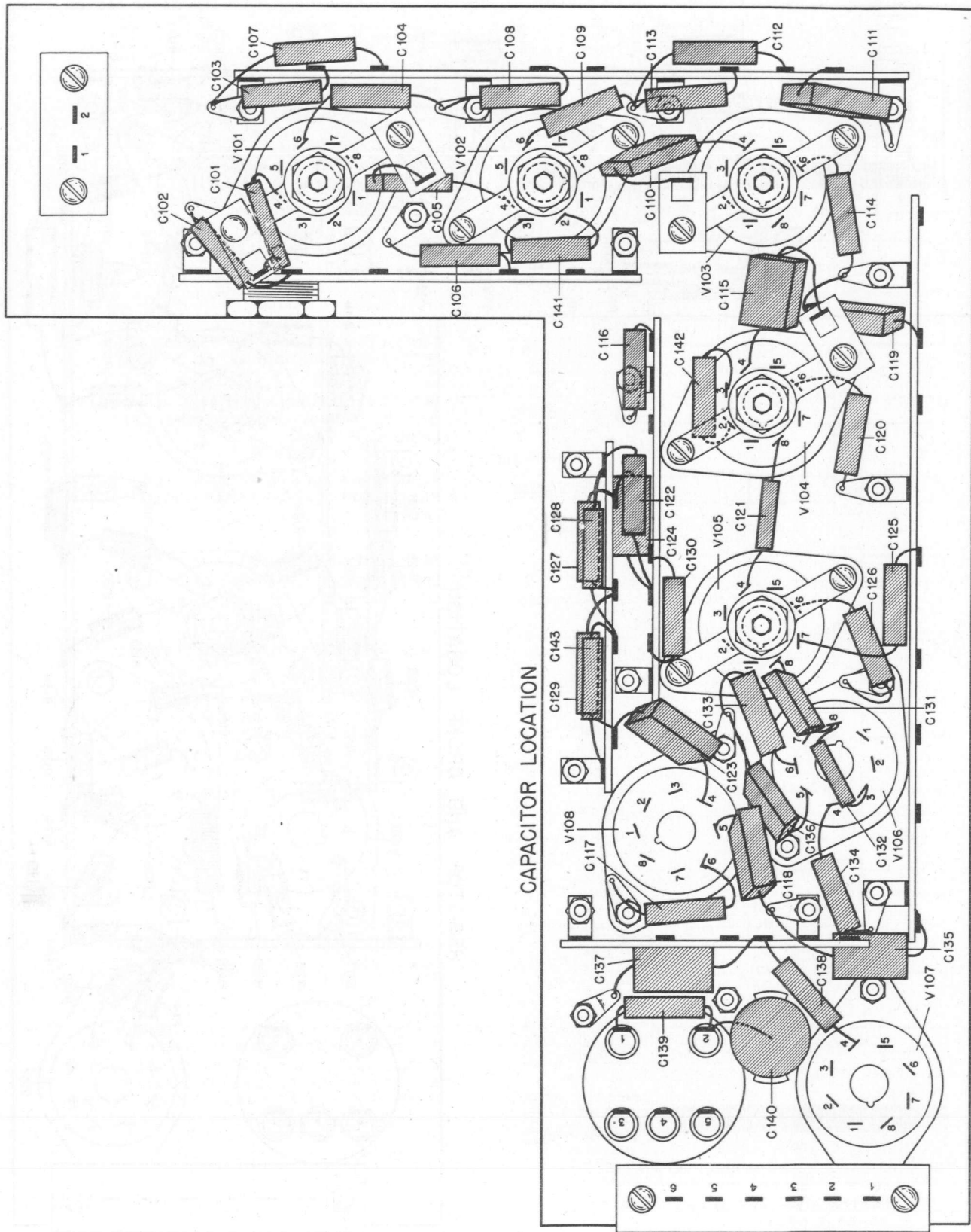

Figure 6-68. Amplifier Strip AM-12/APR-1, Capacitor Location.

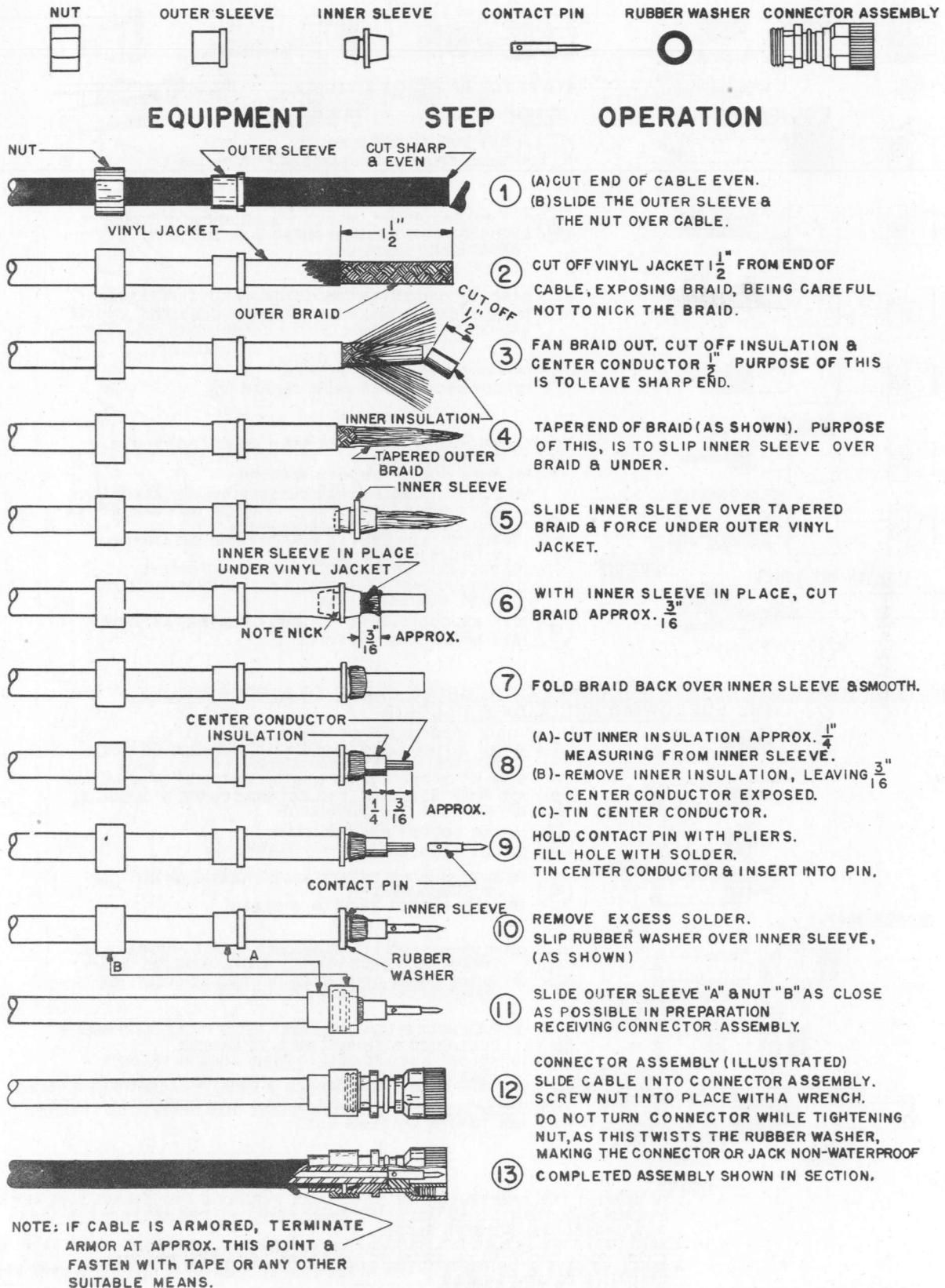
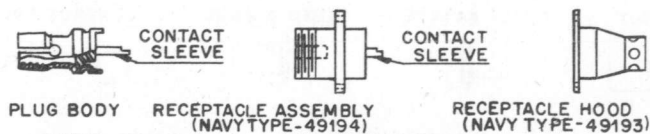
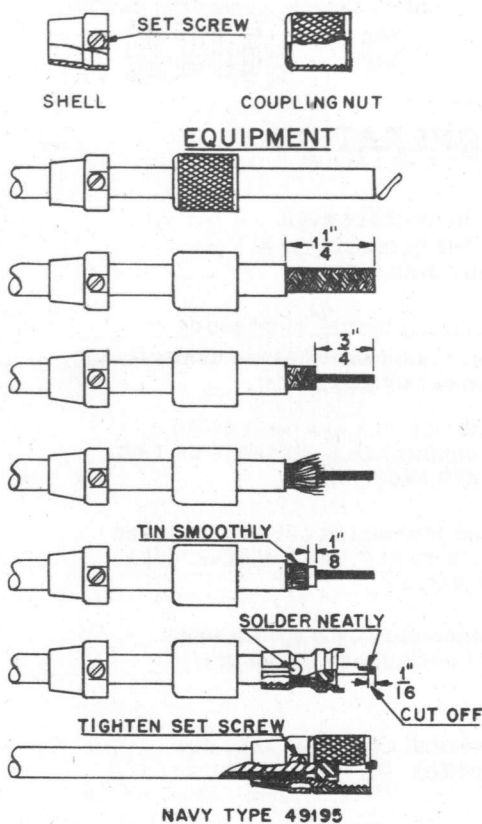

Figure 6-69. Connector Assembly.

RESTRICTED  
AN-16-30APR-1-3  
NAVSHIPS 900, 483A



- STEP OPERATION**
- 1 (A) CUT END OF CABLE SQUARE & CLEAN.  
(B) SLIDE SHELL & COUPLING NUT OVER CABLE.
  - 2 CUT OUTER VINYLITE JACKET  $1\frac{1}{4}$ " FROM END OF CABLE EXPOSING COPPER BRAID SHEATH. DO NOT NICK COPPER BRAID SHEATH.
  - 3 BARE  $\frac{3}{4}$ " OF CENTER CONDUCTOR, BY CUTTING COPPER BRAID SHEATH & INNER INSULATION (DIELECTRIC), SQUARE AND CLEAN. DO NOT NICK CENTER CONDUCTOR.
  - 4 (A) FAN COPPER BRAID SHEATH.  
(B) CUT BACK COPPER BRAID SHEATH  $\frac{1}{8}$ "
  - 5 (A) SMOOTH & TIN COPPER BRAID SHEATH. DO NOT USE EXCESSIVE HEAT.  
(B) WIPE SOLDER SMOOTH & CLEAN.
  - 6 (A) SCREW PLUG-BODY OVER OUTER VINYLITE JACKET UNTIL  $\frac{1}{8}$ " OF INNER CONDUCTOR IS EXPOSED. TAKE CARE NOT TO PUSH BACK COPPER BRAID SHEATH.  
(B) SOLDER PLUG BODY TO COPPER BRAID SHEATH THRU 4 HOLES IN PLUG BODY.  
(C) SOLDER INNER CONDUCTOR TO CONTACT SLEEVE.  
(D) CUT OFF PART OF INNER CONDUCTOR THAT PROJECTS PAST CONTACT SLEEVE.
  - 7 (A) SLIDE COUPLING NUT & SHELL FORWARD AS SHOWN.  
(B) TIGHTEN SCREW IN SHELL.

IF IT BECOMES NECESSARY TO CONNECT THE ABOVE CABLE TO A RECEPTACLE THE FOLLOWING PROCEDURE IS USED:

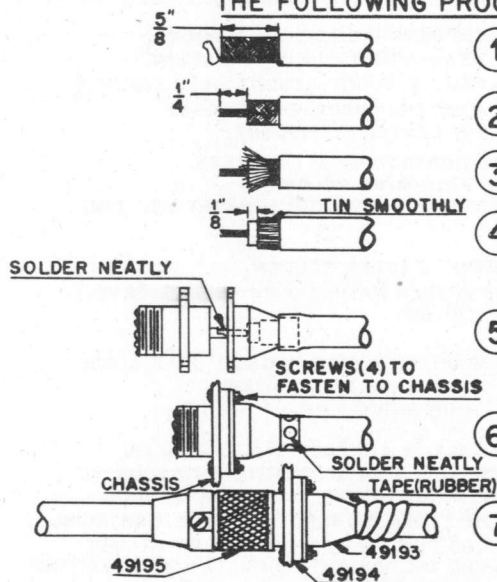

- 1 (A) CUT END OF CABLE SQUARE & CLEAN.  
(B) CUT OUTER VINYLITE JACKET  $\frac{5}{8}$ " FROM END OF CABLE EXPOSING COPPER BRAID SHEATH.
- 2 BARE  $\frac{1}{4}$ " OF INNER CONDUCTOR, BY CUTTING COPPER BRAID AND INNER INSULATION (DIELECTRIC) SQUARE & CLEAN. DO NOT NICK CENTER CONDUCTOR.
- 3 (A) FAN COPPER BRAID SHEATH.  
(B) CUT BACK COPPER BRAID SHEATH  $\frac{1}{8}$ "
- 4 (A) SMOOTH & TIN COPPER BRAID SHEATH. DO NOT USE EXCESSIVE HEAT.  
(B) WIPE SOLDER SMOOTH & CLEAN.
- 5 (A) SLIDE RECEPTACLE HOOD OVER TINNED COPPER BRAID SHEATH AND FORCE UNDER VINYLITE JACKET AS SHOWN  
(B) PLACE INNER CONDUCTOR IN CONTACT SLEEVE OF RECEPTACLE ASSEMBLY & SOLDER.
- 6 (A) PUSH HOOD FLUSH UP AGAINST RECEPTACLE ASSEMBLY & BOLT HOOD WITH ASSEMBLY TO CHASSIS.  
(B) SOLDER HOOD TO COPPER BRAID SHEATH, THROUGH 4 HOLES IN HOOD.  
(C) TAPE AT JUNCTION OF HOOD & VINYLITE JACKET (IF NECESSARY).
- 7 INSERT PLUG BODY CONTACT SLEEVE INTO RECEPTACLE ASSEMBLY AND TIGHTEN COUPLING NUT.

**NOTES:**

1. TO CONNECT TWO CABLES, FOLLOW PROCEDURE FOR PLUG ABOVE (NAVY TYPE 49195) ON EACH END, THEN SCREW (NAVY TYPE 49191) SPLICE FITTING (SEE PAGE D-G-17.2 IN R.I.P. CHANGE #33) INTO BOTH PLUGS.
2. ARMY NAVY TYPE NO'S. RG-8/U, RG-10/U, RG-11/U, & RG-12/U, SUPERSEDE CABLE TYPE NO'S. CASSF-50-1, CASSF-50-1A, CASSF-70-1 & CASSF-70-1A RESPECTIVELY.
3. REFER TO PART C, OF THE R.I.P. FOR OTHER NON-WEATHERPROOF CONNECTORS FOR USE WITH 50 & 70 OHM CABLES.

Figure 6-70. Connector Assembly.

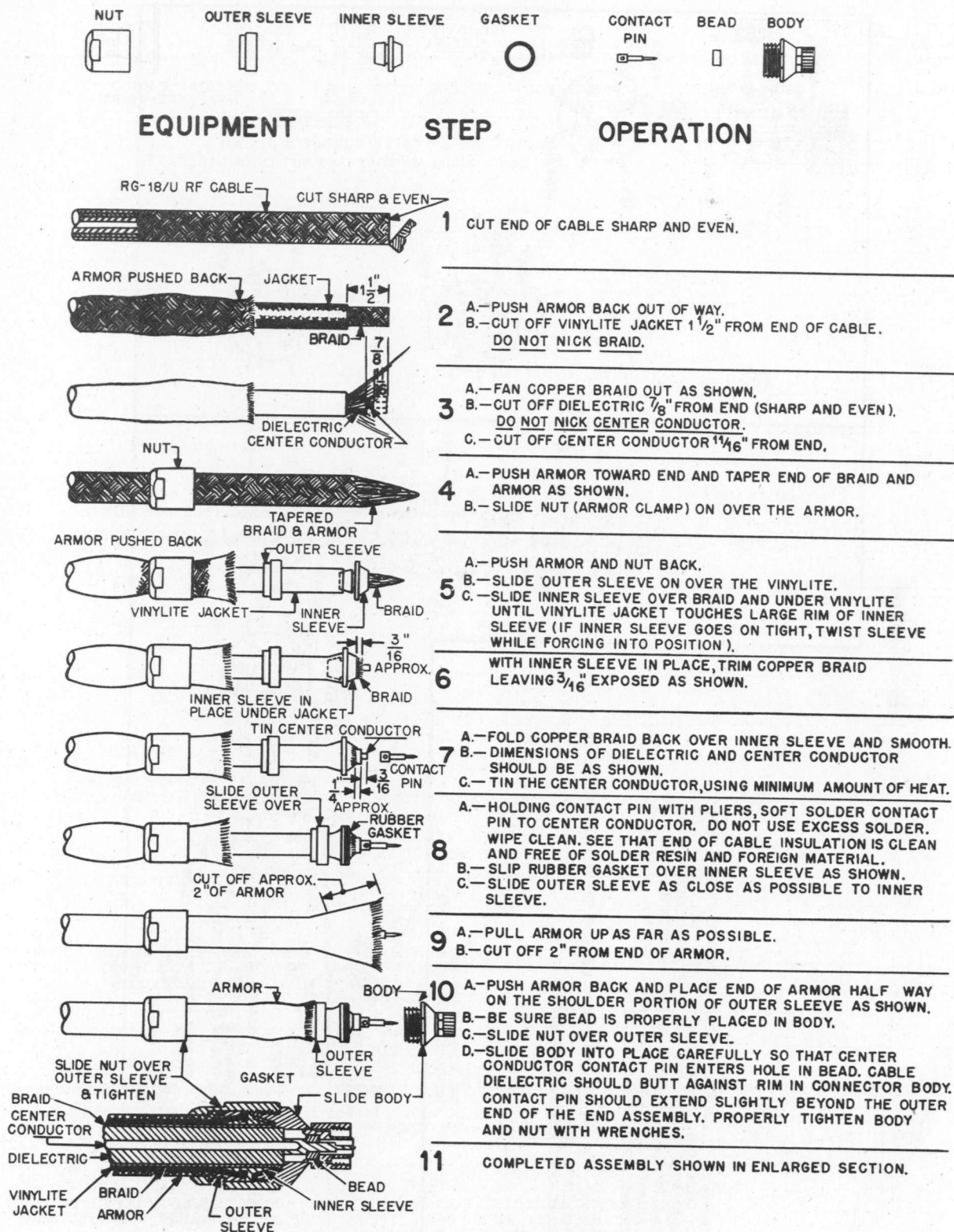

ARMY-NAVY UG-167/U IS FORMER NT NO.49483A  
UG-167/U CONNECTS DIRECTLY WITH UG-22/U,  
UG-23/U & UG-58/U.

Figure 6-71. Connector Assembly.

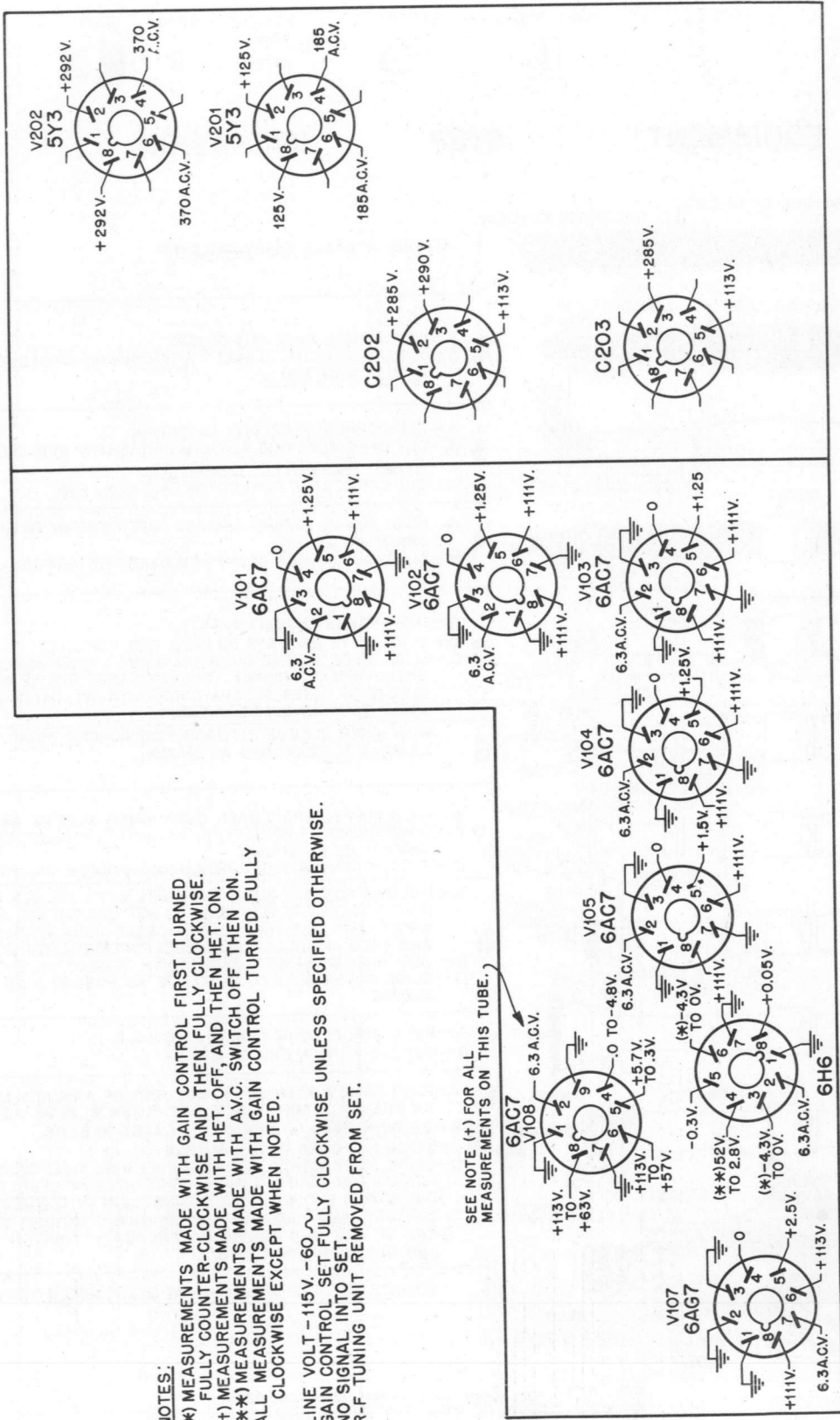

**NOTES:**  
(\*) MEASUREMENTS MADE WITH GAIN CONTROL FIRST TURNED FULLY COUNTER-CLOCKWISE AND THEN FULLY CLOCKWISE.  
(†) MEASUREMENTS MADE WITH HET. OFF, AND THEN HET. ON.  
(\*\*\*) MEASUREMENTS MADE WITH A.V.C. SWITCH OFF THEN ON.  
ALL MEASUREMENTS MADE WITH GAIN CONTROL TURNED FULLY CLOCKWISE EXCEPT WHEN NOTED.  
LINE VOLT -115V. -60~  
GAIN CONTROL SET FULLY CLOCKWISE UNLESS SPECIFIED OTHERWISE.  
NO SIGNAL INTO SET.  
R-F TUNING UNIT REMOVED FROM SET.

SEE NOTE (†) FOR ALL MEASUREMENTS ON THIS TUBE.

Figure 6-72. Amplifier Strip AM-12/APR-1 and Rectifier PP-10/APR-1, Tube Socket Voltage Diagram.

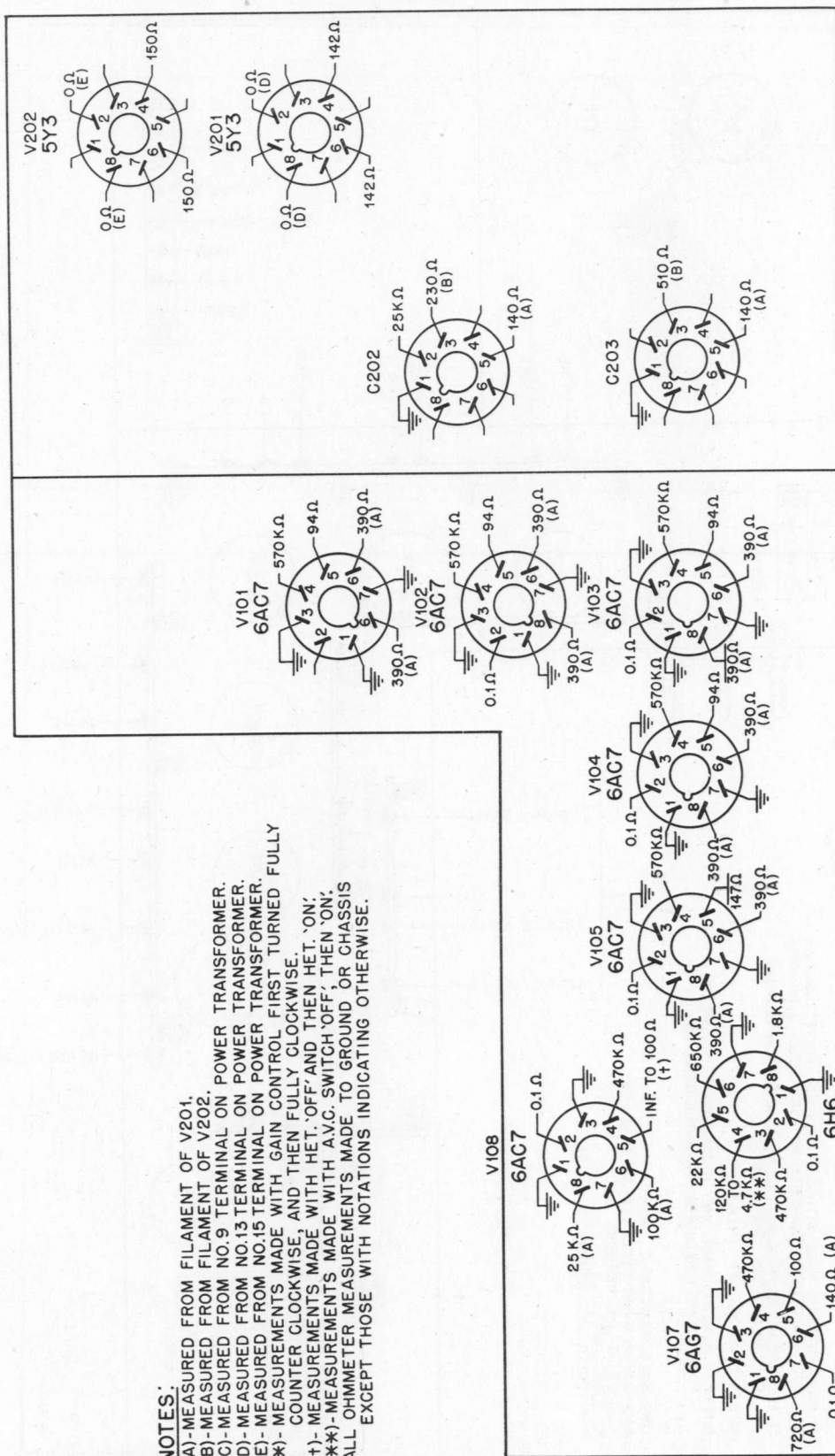

Figure 6-73. Amplifier Strip AM-12/APR-1, Chassis Tube Socket Resistance Diagram, Bottom View.

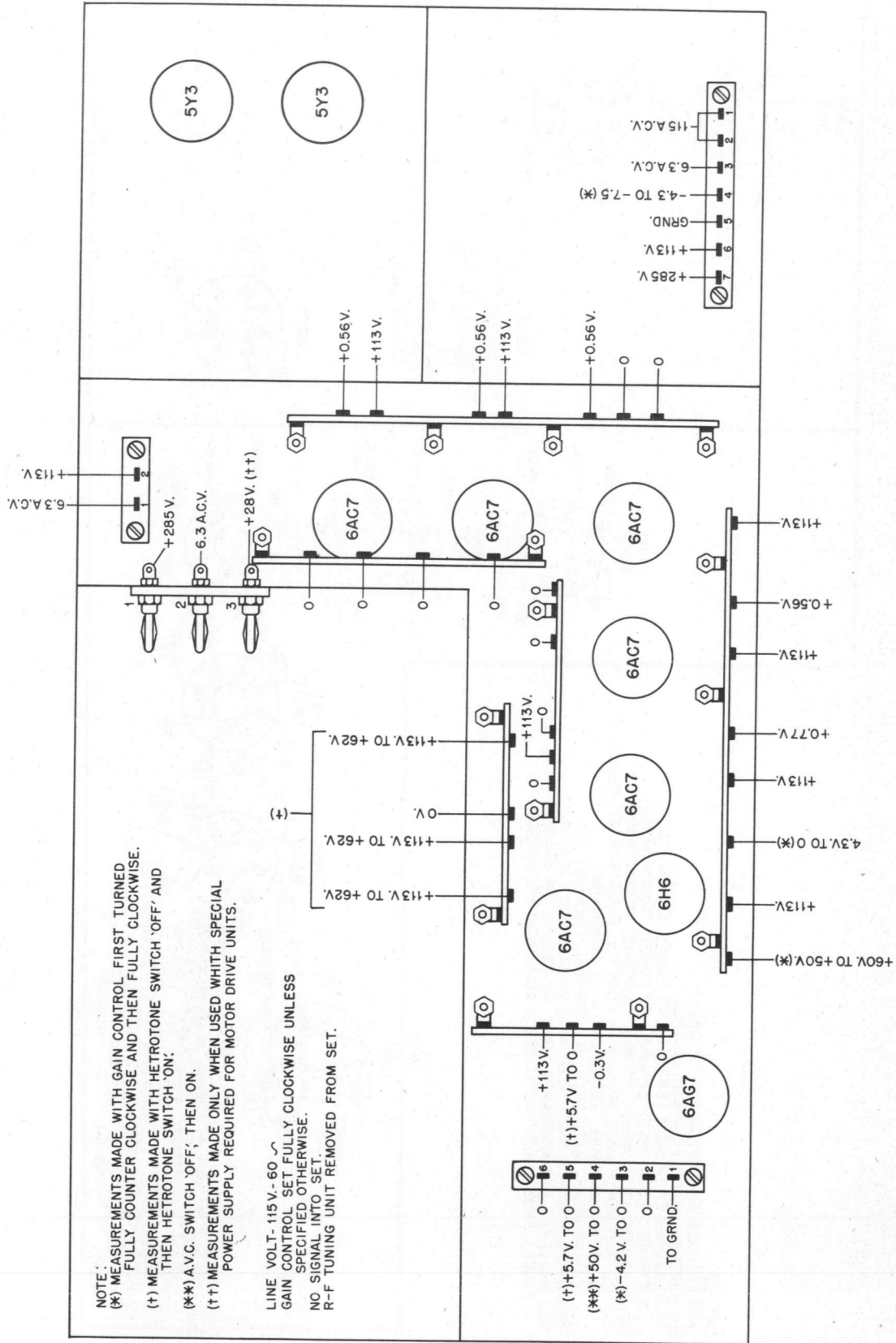

Figure 6-74. Amplifier Strip AM-12/APR-1 and Rectifier PP-10/APR-1, Terminal Board Voltage Diagram.



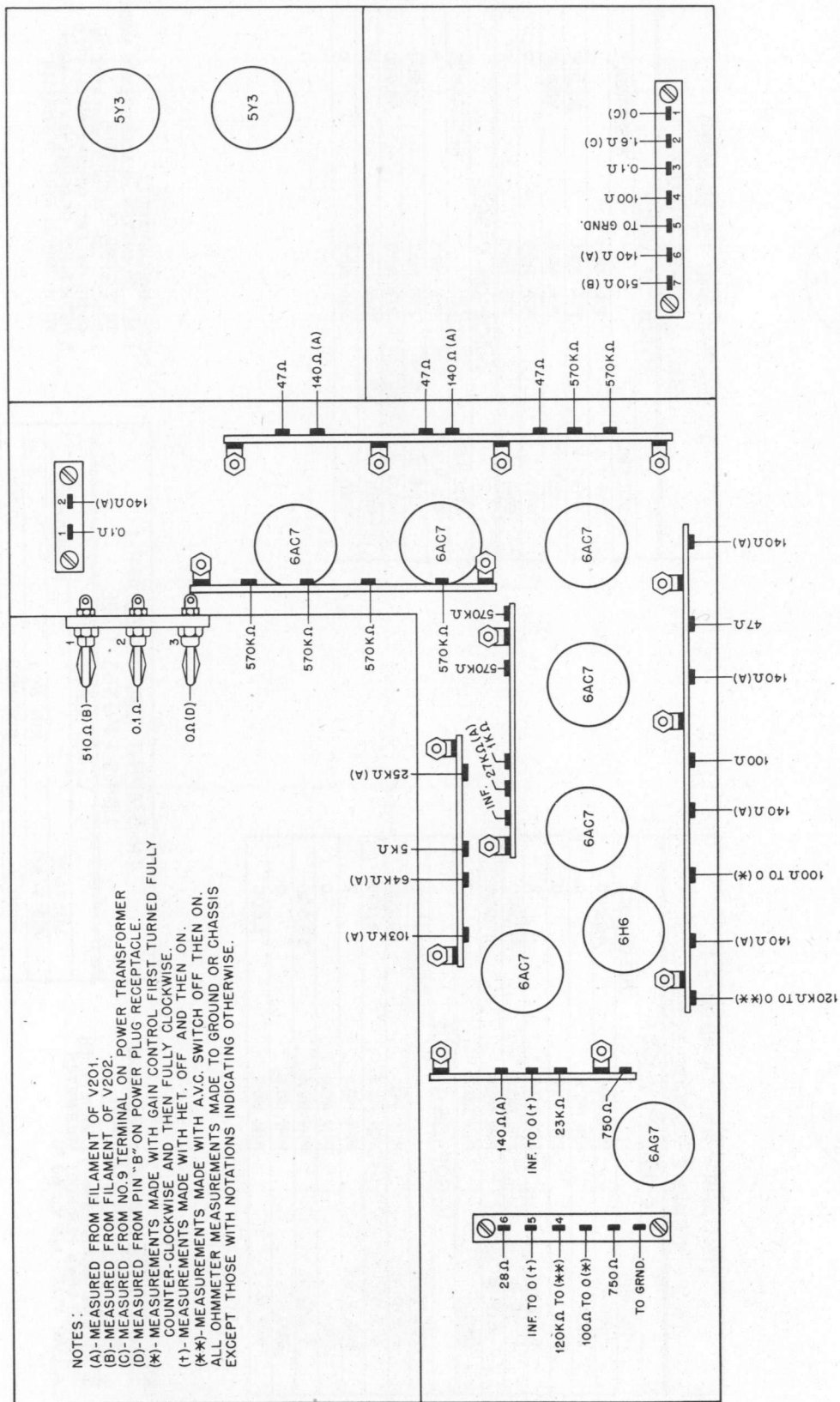
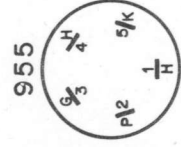
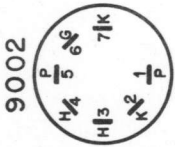

Figure 6-75. Amplifier Strip AM-12/APR-1 and Rectifier PP-10/APR-1, Terminal Board Resistance Diagram.



TN-2/APR-1 AND TN-2B/APR-1 USING 2 NO.955 TUBES		
V-501 OR V-901		
VOLTAGE	PIN NO.	RESISTANCE
6.3 V. A.C.	PIN NO.1	.1
+130 V.	PIN NO.2	50,000
2.5 V.	PIN NO.3	25,000
GND.	PIN NO.4	0
GND.	PIN NO.5	0
V-502 OR V-902		
VOLTAGE	PIN NO.	RESISTANCE
6.3 V. A.C.	PIN NO.1	.1
-1.5 V.	PIN NO.2	15,000
-1.5 V.	PIN NO.3	15,000
GND.	PIN NO.4	0
GND.	PIN NO.5	0

TN-1/APR-1 AND TN-1B/APR-1 USING 2 NO.9002 TUBES		
V-601 OR V-1001		
VOLTAGE	PIN NO.	RESISTANCE
+130 V.	PIN NO.1	40,000
GND.	PIN NO.2	0
GND.	PIN NO.3	0
6.3 V. A.C.	PIN NO.4	.2
+130 V.	PIN NO.5	40,000
-2.5 V.	PIN NO.6	27,000
GND.	PIN NO.7	0
V-602 OR V-1002		
VOLTAGE	PIN NO.	RESISTANCE
+210 V.	PIN NO.1	30,000
+7 V.	PIN NO.2	5,000
6.3 V. A.C.	PIN NO.3	.2
GND.	PIN NO.4	0
+210 V.	PIN NO.5	30,000
GND.	PIN NO.6	0
+7 V.	PIN NO.7	5,000



NOTE: (RESISTANCE)  
1. ALL OHMMETER MEASUREMENTS MADE TO GROUND OR CHASSIS  
2. RESISTANCE VALUES INDICATED IN OHMS UNLESS OTHERWISE STATED  
3. RESISTANCE MEASUREMENTS MADE WITH TUNING UNIT IN CHASSIS

TN-3/APR-1 AND TN-3B/APR-1 USING 1 NO.955 TUBE		
V-401 OR V-701		
VOLTAGE	PIN NO.	RESISTANCE
6.3 V. A.C.	PIN NO.1	.1
+110 V.	PIN NO.2	50,000
-3 V.	PIN NO.3	29,700
GND.	PIN NO.4	0
GND.	PIN NO.5	0

NOTE: (VOLTAGE)  
1. GAIN CONTROL SET FULLY CLOCKWISE UNLESS SPECIFIED OTHERWISE  
2. NO SIGNAL INTO SET  
3. VOLTAGE MEASUREMENTS MADE WITH 20,000 OHMS PER VOLT VOLTMETER  
4. LINE VOLT - 115 V. - 60  $\sim$

Figure 6-76. Tuning Units, Tube Socket and Resistance Diagram.

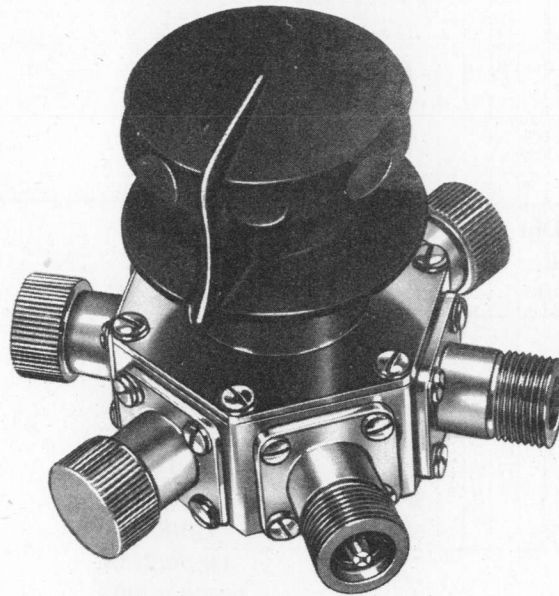

Figure 6-77. R. F. Switch SA-44(A)/APR, Top View.

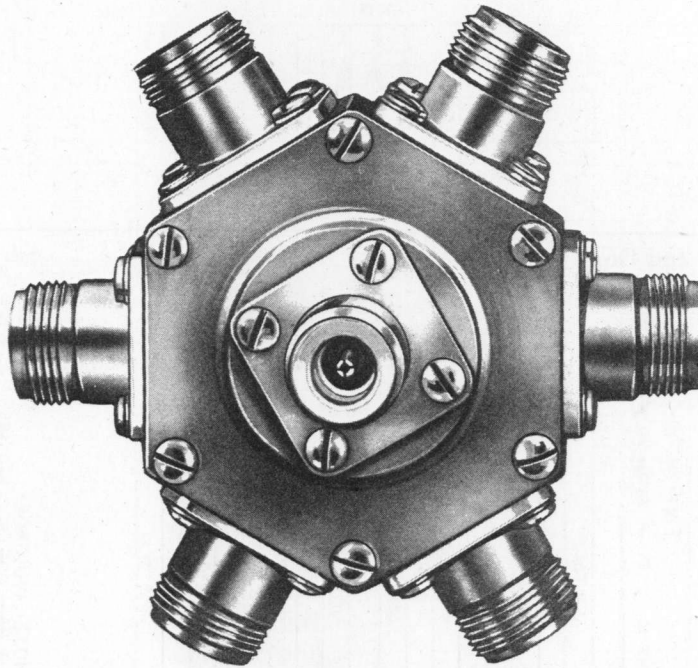
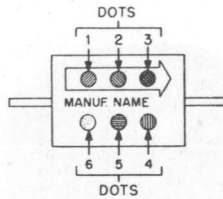

Figure 6-78. R. F. Switch SA-44(A)/APR, Bottom View.

4. AMERICAN WAR STANDARD 6-DOT COLOR CODE CHART  
For Capacitors (Molded Mica)



Color	1st Dot <i>1st</i> Digit	2nd Dot <i>2nd</i> Digit	3rd Dot <i>3rd</i> Digit	4th Dot <i>Decimal</i> Multiplier	5th Dot  Tolerance	6th Dot  Charac- teristics
Black	0	0	0	1	± 20%	*A
Brown	1	1	1	10		B
Ted	2	2	2	100	± 2%	C
Orange	3	3	3	1,000		D
Yellow	4	4	4	10,000		E
Green	5	5	5	100,000		F
Blue	6	6	6	1,000,000		G
Violet	7	7	7	10,000,000		
Gray	8	8	8	100,000,000		
White	9	9	9	1,000,000,000		
Gold	...	...	...	0.1	± 5%	
Silver	...	...	...	0.01	± 10%	

RMA STANDARD 6-DOT COLOR CODE CHART  
For Capacitors (Molded Mica)

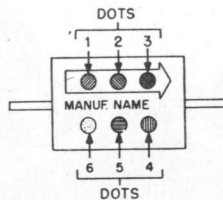

Color	1st Dot <i>1st</i> Digit	2nd Dot <i>2nd</i> Digit	3rd Dot <i>3rd</i> Digit	4th Dot <i>Decimal</i> Multiplier	5th Dot  Tolerance	6th Dot  Voltage
Black	0	0	0	1	....	....
Brown	1	1	1	10	1%	100 v.
Red	2	2	2	100	2%	200 v.
Orange	3	3	3	1,000	3%	300 v.
Yellow	4	4	4	10,000	4%	400 v.
Green	5	5	5	100,000	5%	500 v.
Blue	6	6	6	1,000,000	6%	600 v.
Violet	7	7	7	10,000,000	7%	700 v.
Gray	8	8	8	100,000,000	8%	800 v.
White	9	9	9	1,000,000,000	9%	900 v.
Gold	...	...	...	0.1		1000 v.
Silver	...	...	...	0.01	10%	2000 v.
Body	...	...	...	.....	20%	500 v.

RMA STANDARD COLOR CODE CHART  
For Resistors

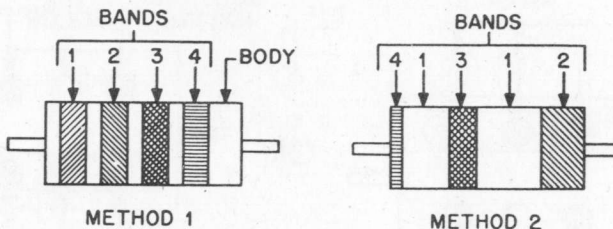

Color	1st Band <i>1st Digit</i>	2nd Band <i>2nd Digit</i>	3rd Band <i>Decimal Multiplier</i>	4th Band <i>Tolerance</i>
Black	0	0	1	
Brown	1	1	10	
Red	2	2	100	
Orange	3	3	1,000	
Yellow	4	4	10,000	
Green	5	5	100,000	
Blue	6	6	1,000,000	
Violet	7	7	10,000,000	
Gray	8	8	100,000,000	
White	9	9	1,000,000,000	
Gold	...	...	.....	± 5%
Silver	...	...	.....	± 10%
No Color	...	...	.....	± 20%

COLOR CODE CHART  
For Capacitors (Tubular Ceramic)

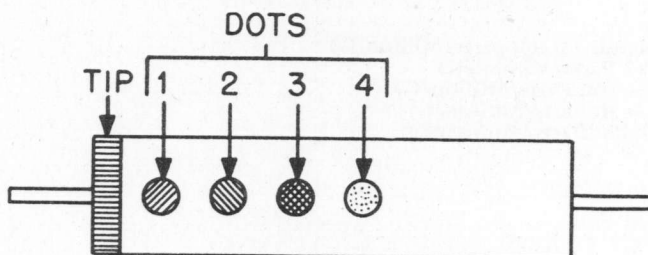

Color	Tip <i>Temperature Coefficient</i>	1st Dot <i>1st Digit</i>	2nd Dot <i>2nd Digit</i>	3rd Dot <i>Decimal Multiplier</i>	4th Dot <i>Tolerance</i>
Black	0	0	0	1	...
Brown	.00003 Neg.	1	1	10	1%
Red	.00008 "	2	2	100	2%
Orange	.00015 "	3	3	1,000	3%
Yellow	.00022 "	4	4	10,000	4%
Green	.00033 "	5	5	100,000	5%
Blue	.00047 "	6	6	1,000,000	6%
Violet	.00075 "	7	7	10,000,000	7%
Gray		8	8	0.1	
White		9	9	0.01	10%

3-DOT COLOR CODE CHART  
For Capacitors

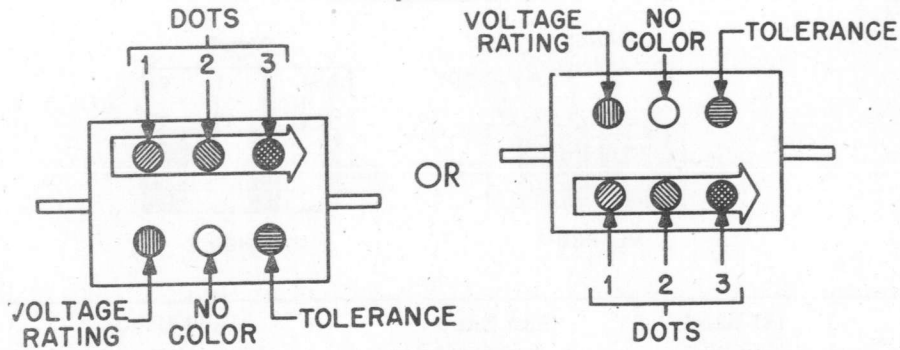

Color	1st Dot	2nd Dot	3rd Dot	Tolerance	Voltage Rating
	1st Digit	2nd Digit	Decimal Multiplier		
Black	0	0	1		
Brown	1	1	10	1%	100 v.
Red	2	2	100	2%	200 v.
Orange	3	3	1,000	3%	300 v.
Yellow	4	4	10,000	4%	400 v.
Green	5	5	100,000	5%	500 v.
Blue	6	6	1,000,000	5%	600 v.
Violet	7	7	10,000,000	7%	700 v.
Gray	8	8	100,000,000	8%	800 v.
White	9	9	1,000,000,000	9%	900 v.
Gold	...	...	0.1		1000 v.
Silver	...	...	0.01	10%	2000 v.
Body	...	...	.....	20%	*

- \*—Ordinary Mica By-pass.
- B—Same as A—Low Loss Case.
- C—By-pass or Silver Mica Capacitor ( $\pm 200$  parts/Million/C)
- D—Silver Mica Capacitor ( $\pm 100$  Parts/Million/C)
- E—Silver Mica Capacitor (0 to +100 Parts/Million/C)
- F—Silver Mica Capacitor (0 to +50 Parts/Million/C)
- G—Silver Mica Capacitor (0 to 050 Parts/Million/C)

**TABLE OF  
REPLACEABLE PARTS**

"Where no JAN or Navy Standard part number is given to a component, care should be taken in replacing the component with any other part than that listed in the Table of Replaceable Parts. This special part probably has been chosen for a special quality not available in standard components, and use of a standard component may result in decreased life or lowered performance."

TABLE OF REPLACEABLE PARTS  
MODEL: Radio Receiving Equipment AN/APR-1 and AN/SPR-1 MAJOR UNIT: Amplifier Strip-AM-12/APR-1

Reference Symbol	Navy Stock No.	Name of Part and Description	Function	Mfr. and Desig. or AWS Type	Cont. or Gov't Dwg. or Spec. No.
A-101		CHASSIS BASE, I. F.: aluminum, lacquered; L shaped; .064" thick; 1 leg; 9/8" long, 2 7/8" wide; 1 leg: 1 1/16" long, 4" wide; punched for parts mounting.	I. F. chassis base.	1	IK60791
A-102		CLAMP, TUBE: stainless steel; 3/8" wide band, snap type lock; holds 1 7/32" diameter tube; mounting bracket 1/2" wide, 3/8" high, 3/8" long, 1/4" hole for mounting.	Tube retainer.	1	42K52144
A-103		SPACER, I. F. COIL: aluminum, lacquered; 1/4" diameter, hexagonal; 1 1/8" long; both ends tapped 6-32 threads, 3/8" deep.	Mount I. F. coils and terminal strips.	1	46A61313
A-104		SUPPORT, COIL: aluminum, lacquered; .064" thick, 1.75" long, 5/8" diameter at center, 9/32" wide at ends; center hole 3/8" diameter, 2 holes at ends .147" diameter.	Mount I. F. coils.	1	7A61314-
A-105		TERMINAL STRIP: phenolic, grade XX; .078" thick, 3/8" wide, 6 3/16" long; 9 Cinch solder lugs #1437; 3 Cinch brackets #1457.	Tie point.	9	31B61322
A-106		TERMINAL STRIP: phenolic, grade XX; natural vacuum impregnated with ceres "A-A" wax; polished surface; 4 terminal lugs; 2 brackets (Cinch #1457) on strip for mounting; 2 7/8" long, 3/4" wide.	Tie point.	9	31A61306
A-107		TERMINAL STRIP: phenolic, grade XX; 3/32" thick, 5/8" wide, 2 13/16" long; 2 holes .156" diameter for mounting; 6 solder terminals.	Tie point.	13	31A61311
A-108		TERMINAL STRIP: phenolic, grade XX; 3/32" thick, 5/8" wide, 1 1/2" long; 2 holes .156" diam. for mounting; 2 solder terminals.	Tie point.	13	31A61312
A-109		TERMINAL STRIP: phenolic, grade XX; .078" thick, 3/8" wide, 3 9/16" long; 2 Cinch brackets #1457 for mounting, 5 Cinch lugs #1437.	Tie point.	9	31A61307
A-110		TERMINAL STRIP: natural phenolic, grade XX; vacuum impregnated with ceres "A-A" wax; 7 insulated lugs; 4 mounting brackets; 6 1/4" long, 3/8" wide strip.	Tie point.	9	31B61321
A-111		TERMINAL STRIP: phenolic, grade XX; .078" thick, 3/8" wide, 4 5/16" long; 4 Cinch lugs #1437; 2 Cinch brackets #1457.	Tie point.	9	31A61309
A-112		TERMINAL STRIP: phenolic, grade XX; .078" thick, 3/8" wide, 3 1/4" long; 4 Cinch soldering lugs #1437; 2 Cinch brackets #1457 for mounting.	Tie point.	9	31A61308
A-113		TERMINAL STRIP: phenolic, grade XX; 3/4" long, 3/8" wide, 1/16" thick; 1 hole for #6 screw; 1 terminal lug.	Mount resistors R143, R144, R145, R146.	9	31A101218
C-101	R16-C-9924-59	CAPACITOR: fixed; mica; 100 micro-microfarads ±10%; 500 V. D-C working; tan mica case; color coded: brown, black, brown, silver; 1 1/16" long, 7/16" wide, 11/64" thick; axial leads.	Input coupling to V101.	2 #1468X	21R6574
C-102	R16-C-10400-440	CAPACITOR: fixed; paper; 5000 micro-microfarads +60% -10%; 150 V. D-C working; .765" long, .484" wide, 1/4" thick; #20 T.C.W. copper axial leads, 1 3/8" long.	A. V. C. by-pass V101.	10 #1468X SM5	8A48529
C-103		CAPACITOR: same as C102.	Cathode by-pass, V101.		



TABLE OF REPLACEABLE PARTS

MAJOR UNIT: Amplifier Strip-AM-12/APR-1

MODEL: Radio Receiving Equipment AN/APR-1 and AN/SPR-1

Reference Symbol	Navy Stock No.	Name of Part and Description	Function	Mfr. and Desig. or AWS Type	Cont. or Gov't Dug. or Spec. No.
C-104		CAPACITOR: same as C102.	Screen by-pass, V101.		
C-105		CAPACITOR: same as C101.	Coupling V101 to V102.		
C-106		CAPACITOR: same as C102.	A.V.C. by-pass, V102.		
C-107		CAPACITOR: same as C102.	B+ by-pass.		
C-108		CAPACITOR: same as C102.	Cathode by-pass, V102.		
C-109		CAPACITOR: same as C102.	Screen by-pass, V102.		
C-110		CAPACITOR: same as C101.	Coupling V102 to V103.		
C-111		CAPACITOR: same as C102.	A.V.C. by-pass, V103.		
C-112		CAPACITOR: same as C102.	A.V.C. by-pass.		
C-113		CAPACITOR: same as C102.	Cathode by-pass, V103.		
C-114		CAPACITOR: same as C102.	Screen by-pass, V103.		
C-115		CAPACITOR: same as C101.	Coupling V103 to V104.		
C-116		CAPACITOR: same as C102.	A.V.C. by-pass, V104.		
C-117		CAPACITOR: same as C102.	Screen by-pass, V104 and V108.		
C-118		CAPACITOR: same as C102.	Cathode by-pass, V108.		
C-119		CAPACITOR: same as C102.	Cathode by-pass, V104.		
C-120		CAPACITOR: same as C102.	Screen by-pass, V104.		
C-121		CAPACITOR: same as C101.	Coupling V104 to V105.		
C-122		CAPACITOR: same as C102.	V105 grid circuit by-pass.		
C-123		CAPACITOR: same as C102.	Coupling to oscillator network, V108.		
C-124		CAPACITOR: same as C102.	Coupling V108 to V105.		
C-125		CAPACITOR: same as C102.	Cathode by-pass, V105.		
C-126		CAPACITOR: same as C102.	Screen by-pass, V105.		
C-127		CAPACITOR: same as C102.	Part of oscillator network, V108.		
C-128		CAPACITOR: same as C102.	Part of oscillator network, V108.		

MODEL: Radio Receiving Equipment AN/APR-1 and AN/SPR-1		MAJOR UNIT: Amplifier Strip-AM-12/APR-1			
Reference Symbol	Navy Stock No.	Name of Part and Description	Function	Mfr. and Desig. or AWS Type	Cont. or Gov't Drug. or Spec. No.
C-129		CAPACITOR: same as C102.	Part of oscillator network, V108.		
C-130		CAPACITOR: same as C102.	Blocking, V105.		
C-131	R16-C-9843-52-75	CAPACITOR: fixed; mica; 50 micro-microfarads $\pm 10\%$ ; 400 V. D-C working; red mica case; color coded: green, black, silver; $1\frac{1}{16}$ " long, $\frac{7}{16}$ " wide, $\frac{1}{64}$ " thick; axial leads, $1\frac{1}{4}$ " long.	Coupling V105 to V106.	2 #1468X	21B6578
C-132		CAPACITOR: same as C131.	Coupling V105 to V106.		
C-133		CAPACITOR: same as C102.	A.V.C. by-pass, V106.		
C-134		CAPACITOR: same as C102.	Cathode by-pass, V106.		
C-135		CAPACITOR: same as C102.	By-pass, V106.		
C-136	R16-C-9807	CAPACITOR: fixed; mica; 10 micro-microfarads $\pm 10\%$ ; 400 V. D-C working; tan mica case; color coded: brown, black, silver; $1\frac{1}{16}$ " long, $\frac{7}{16}$ " wide, $\frac{1}{16}$ " thick; axial leads.	V106 diode load.	2 #1468X	21B6575
C-137		CAPACITOR: same as C136.	R. F. filter, V106.		
C-138		CAPACITOR: same as C102.	Coupling V106 to V107.		
C-139	R16-C-10083-115	CAPACITOR: fixed; mica; 1,000 micro-microfarads $\pm 10\%$ ; 400 V. D-C working; tan mica case; color coded: brown, black, red, silver; $1\frac{1}{16}$ " long, $\frac{7}{16}$ " wide, $\frac{1}{64}$ " thick; axial leads.	High-frequency cut-off (A.F.), V107.	19 "C"	21B6663
C-140	R16-C-11687-750	CAPACITOR: fixed; paper dielectric, oil-impregnated; 25 microfarads; $\pm 20\%$ ; 200 V. D-C working; $1\frac{5}{16}$ " long, $\frac{7}{8}$ " diameter.	B+ by-pass.	1	8A31207
C-141		CAPACITOR: same as C102.	Filament by-pass.		
C-142		CAPACITOR: same as C102.	Filament by-pass.		
C-143		CAPACITOR: same as C102.	Oscillator network.		
C-144		CAPACITOR: same as C102.	Parasitic suppressor.		
E-101		ASSEMBLY, I. F. COIL AND SUPPORT: composed of I. F. coil L101 and coil support A104.	Plate tuning inductor.	1	1X48518
E-102		ASSEMBLY, I. F. COIL AND SUPPORT: composed of I. F. coil L105 and coil support A104.	Plate tuning inductor.	1	1X48519
E-103		LUG, SOLDERING: brass, hot tin dipped, .020" thick, #6 mounting lock bent; two .075" diameter wire holes.	Tie point.	22 #2104-6L	29B5248
E-104		I. F. POWER SUPPLY CHASSIS: complete, less tubes; overall dimensions: $4\frac{7}{8}$ " x $9\frac{7}{8}$ " x $11\frac{5}{16}$ ".	I-F Chassis.	1	1X42800

TABLE OF REPLACEABLE PARTS  
MODEL: Radio Receiving Equipment AN/APR-1 and AN/SPR-1

MAJOR UNIT: Amplifier Strip-AM-12/APR-1

Reference Symbol	Navy Stock No.	Name of Part and Description	Function	Mfr. and Desig. or AWS Type	Cont. or Gov't Dwg. or Spec. No.
H-101		LOCKWASHER: #6 external; 5/16" outside diameter, .142"-.150" inside diameter, .018" thick; spring steel, white cadmium finish.	General.	22 #1106	457666
H-102		NUT: 6-32 thread, 5/16" long, hexagonal; 7/64" thick; brass, white nickel finish.	General.	26	758399
H-103		SCREW: 6-32 thread, 5/16" long, slotted flat head; brass, white nickel finish.	Mount capacitor C140 and coil spacer.	26	351242
H-104		SCREW: 6-32 thread, 3/8" long; slotted binder head, brass, white nickel finish.	Mount coil spacers.	26	351234
H-105		SCREW: 6-32 thread, 5/16" long, slotted binder head; brass white nickel finish.	Mount terminal strips.	26	351229
L-101		COIL, I-F: 12 3/4 turns of #30 enameled copper wire, wound on ceramic core, coated with autone cement; variable copper slug tuning; 2 leads on #24 tinned copper wire; 5/16-24 thread mounting stud and hexagonal nut.	Plate tuning inductor, V101.	1	24A48765
L-102		COIL, I-F: same as L-101.	Plate tuning inductor, V101.		
L-103		COIL, I-F: same as L-101.	Plate tuning inductor, V103.		
L-104		COIL, I-F: same as L-101.	Plate tuning inductor, V104.		
L-105		COIL, I-F: 14 1/2 turns of #30 enameled copper wire wound on ceramic core, coated with autone cement; variable copper slug tuning; 2 leads of #24 tinned copper wire; 5/16-24 thread mounting stud and hexagonal nut.	Plate tuning inductor, V105.	1	24A48766
L-106	R16-GV-24A48689	COIL, R.F. CHOKE: 75 turns #36 S.S.E. wire (72") on a 3/4" x 7/32" dummy resistor; two coats of autone; inductance: 11 microhenries ±1.1 microhenries at 8 megacycles.	R.F. choke, diode output, V106.	1	24A48689
L-107		COIL, R.F. CHOKE: same as L-106.	R.F. choke, B+.		
L-108	R16-GV-24A48688	COIL, R.F. CHOKE: 22 turns (24") #22 enameled wire on 3/4" x 7/32" XM bakelite dummy resistor coil form; axial leads of #22 tinned copper wire.	Filament choke.	1	24A48688
L-110		COIL, R.F. CHOKE: same as L-101.	Filament choke.		
R-101	R16-R-17310-59-20SM	RESISTOR: fixed, carbon; 15,000 ohms, ±10%; 1/2 watt; insulated; 3/8" long; .140" diameter; axial leads, 1 1/2" long.	Grid load, V101.	12 23 33	6B6477
R-102	R16-R-17262-55-140SM	RESISTOR: fixed, carbon; 250 ohms, ±10%; 1/2 watt; insulated; 3/8" long, .140" diameter; axial leads, 1 1/2" long.	A.V.C. filter, V101.	4 "EB" Ins.	6B6404
R-103	R16-17258-56-20SM	RESISTOR: fixed, carbon; 47 ohms, ±10%; 1/2 watt; insulated; 3/8" long, .140" diameter; axial leads, 1 1/2" long.	Bias resistor, V101.	4 "EB" Ins.	6B6464

TABLE OF REPLACEABLE PARTS  
MAJOR UNIT: Amplifier Strip-AM-12 / APR-1

Reference Symbol	Navy Stock No.	Name of Part and Description	Function	Mfr. and Desig. or AWS Type	Cont. or Gov't Dwg. or Spec. No.
R-104		RESISTOR: same as R-103.	Bias resistor, V101.		
R-105		RESISTOR: same as R-102.	B+ decoupling V101.		
R-106		RESISTOR: same as R-102.	A.V.C. filter, V102.		
R-107		RESISTOR: same as R-135.	Grid load, V102.		
R-108		RESISTOR: same as R-103.	Bias resistor, V102.		
R-109		RESISTOR: same as R-103.	Bias resistor, V102.		
R-110		RESISTOR: same as R-102.	B+ decoupling V102.		
R-111		RESISTOR: same as R-102.	A.V.C. filter, V103.		
R-112		RESISTOR: same as R-135.	Grid load, V103.		
R-113		RESISTOR: same as R-103.	Bias resistor, V-103.		
R-114		RESISTOR: same as R-103.	Bias resistor, V-103.		
R-115	R16-R-17344-180SM	RESISTOR: fixed, carbon; 100,000 ohms $\pm 10\%$ ; 1/2 watt, insulated; 3/8" long, .140" diameter; axial leads, 1 1/2" long.	V-108 screen grid dropping.	4	6B6369
R-116		RESISTOR: same as R-102.	B+ decoupling V-103.		
R-117	R16-R-17310-172SM	RESISTOR: fixed, carbon; 22,000 ohms $\pm 10\%$ ; 1/2 watt; insulated; 3/8" long, .140" diameter; axial leads, 1 1/2" long.	V-108 plate load.	4 "EB" Ins.	6B6370
R-118		RESISTOR: same as R-102.	A.V.C. filter, V-104.		
R-119		RESISTOR: same as R-135.	Grid load, V-104.		
R-120	R16-R-17261-18SM	RESISTOR: fixed, carbon; 100 ohms $\pm 10\%$ ; 1/2 watt, insulated; 3/8" long, .140" diameter; axial leads, 1 1/2" long.	Bias resistor, V-108.	4 "EB" Ins.	6B6405
R-121		RESISTOR: same as R-103.	Bias resistor, V-104.		
R-122		RESISTOR: same as R-103.	Bias resistor, V-104.		
R-123	R16-R-17354-14-90SM	RESISTOR: fixed, carbon; 470,000 ohms $\pm 10\%$ ; 1/2 watt; insulated; 3/8" long, .140" diameter; axial leads, 1 1/2" long.	Oscillator grid lead, V-108.	4 "EB" Ins.	6B6338
R-124		RESISTOR: same as R-102.	B+ decoupling, V-104.		
R-125	R16-R-17328-205SM	RESISTOR: fixed, carbon; 39,000 ohms $\pm 10\%$ ; 1/2 watt; insulated; 3/8" long, .140" diameter; axial leads, 1 1/2" long.	Part of oscillator network, V-108.	4 "EB" Ins.	6B6466
R-126		RESISTOR: same as R-125.	Part of oscillator network, V-108.		

TABLE OF REPLACEABLE PARTS  
MODEL: Radio Receiving Equipment AN/APR-1 and AN/SPR-1

MAJOR UNIT: Amplifier Strip-AM-12/APR-1

Reference Symbol	Navy Stock No.	Name of Part and Description	Function	Mfr. and Desig. or AWS Type	Cont. or Gov't Dwg. or Spec. No.
R-127	R16-R-17264-138SM	RESISTOR: fixed, carbon; 1000 ohms $\pm 10\%$ ; $\frac{1}{2}$ watt; insulated; $\frac{3}{8}$ " long, $\frac{1}{40}$ " diameter; axial leads, $1\frac{1}{2}$ " long. or: RESISTOR: same as R-135.	Heterotone loading, V-105.	4 "EB" Ins.	6B6335
R-128		RESISTOR: same as R-135.	Grid load, V-105.		
R-129		RESISTOR: same as R-120.	Bias resistor, V-105.		
R-130		RESISTOR: same as R-103.	Bias resistor, V-105.		
R-131	R16-R-17281-148SM	RESISTOR: fixed; carbon; 4,700 ohms $\pm 10\%$ ; $\frac{1}{2}$ watt; insulated; $\frac{3}{8}$ " long, $\frac{1}{40}$ " diameter; axial leads, $1\frac{1}{2}$ " long.	Part of oscillator network, V-108.	4 "EB" Ins.	6B6351
R-132	R16-R-17318-190SM	RESISTOR: fixed, carbon; 27,000 ohms $\pm 10\%$ ; $\frac{1}{2}$ watt; insulated; $\frac{3}{8}$ " long, $\frac{1}{40}$ " diameter; axial leads, $1\frac{1}{2}$ " long.	Panoramascopic coupling resistor, V-106.	4 "EB" Ins.	6B5713
R-133		RESISTOR: same as R-102.	B+ decoupling, V-105.		
R-134		RESISTOR: same as R-115.	By-pass, V-106.		
R-135		RESISTOR: fixed, carbon; 1800 ohms $\pm 10\%$ ; $\frac{1}{2}$ watt; insulated; $\frac{3}{8}$ " long, $\frac{1}{40}$ " diameter; axial leads, $1\frac{1}{2}$ " long.	L-105 load resistor.	4 12 23	6B5712
R-136		RESISTOR: same as R-123.	Diode load, V-106.		
R-137	R16-R-17348-255M	RESISTOR: fixed, carbon; 150,000 ohms $\pm 10\%$ ; $\frac{1}{2}$ watt; insulated; $\frac{3}{8}$ " long, $\frac{1}{40}$ " diameter; axial leads, $1\frac{1}{2}$ " long.	A.V.C. delay, divider network V-106.	4 "EB" Ins.	6B6382
R-138		RESISTOR: same as R-131.	A.V.C. delay, V-106.		
R-139		RESISTOR: same as R-137.	A.V.C. delay, divider network, V-106.		
R-140		RESISTOR: same as R-117.	V-106 diode load.		
R-141		RESISTOR: same as R-123.	Control grid resistor, V-107.		
R-142		RESISTOR: same as R-120.	Bias resistor, V-107.		
R-143		RESISTOR: same as R-103.	Parasitic suppressor.		
R-144	R16-R-17256-42-300LG	RESISTOR: fixed, carbon; 4.7 ohms, $\pm 5\%$ ; $\frac{1}{2}$ watt; insulated; $\frac{7}{16}$ " long, $\frac{2}{18}$ " diameter; axial leads, $1\frac{1}{2}$ " long.	Parasitic suppressor.	33 "504" 48	6B5650
R-145		RESISTOR: same as R-144.	Parasitic suppressor.		
R-146		RESISTOR: same as R-144.	Parasitic suppressor.		

TABLE OF REPLACEABLE PARTS  
MODEL: Radio Receiving Equipment AN/APR-1 and AN/SPR-1

MAJOR UNIT: Amplifier Strip-AM-12/APR-1

Reference Symbol	Navy Stock No.	Name of Part and Description	Function	Mfr. and Desig. or AWS Type	Cont. or Gov't Dwg. or Spec. No.
T-101	R16-GV-25C48625	TRANSFORMER, OUTPUT: core: #29 Birming. gauge Radio #6 iron; center leg 1 5/16" long x 5/8" wide x 2 5/32" high; stack 5/16" x 2 5/32"; window 5/16" wide x 1 5/16" long; fibre air gap; coil form: 3 layers of .007" gummed Kraft paper; primary winding: 2510 turns #39 A.W.G. enameled copper wire; static shield .004" brass stripping .72" wide; secondary #1 winding: 500 turns of #32 A.W.G. enameled copper wire; secondary #2 winding: 1320 turns of #39 A.W.G. enameled copper wire; start of secondary #2 to be connected to finish of secondary #1; paper for insulation between windings and shielding; coil and core vacuum impregnated with petrocene B wax; potting compound #X115 Bi-wax; metal cover: 2 1/16" high, 2 3/32" wide, 2 7/32" long; 4 mounting studs threaded 6-32; primary inductance 7 henries at .025 amperes, 10 volts, 60 cycles.	Audio transformer.	8	25C48625
V-101	16-T-56138	RADIO TUBE: pentode, metal, single ended, heater cathode type.	I-F amplifier.	14	6AC7/1852
V-102		RADIO TUBE: same as V-101.	I-F amplifier.		
V-103		RADIO TUBE: same as V-101.	I-F amplifier.		
V-104		RADIO TUBE: same as V-101.	I-F amplifier.		
V-105		RADIO TUBE: same as V-101.	I-F amplifier.		
V-106	16-T-56346	RADIO TUBE: single ended, metal, heater cathode type, standard octal base, two diodes in one envelope.	Detector A.V.C.	14	6H6
V-107		RADIO TUBE: video power; heater type, standard octal base.	A-F cathode follower.	14	6AG7
V-108		RADIO TUBE: same as V-101.	Heterotone oscillator.		
X-101	R16-S-6188-5	SOCKET, TUBE: steatite body; 1 1/4" diameter; 9/16" high; mounting plate: .064" thick aluminum, 1 3/8" wide, 2 5/32" long, saddle type; 8 contact receptacles.	Tube socket for tubes V-106 and V-107.	5	9A103950
X-102	R16-S-6188-5	SOCKET, TUBE: steatite body; 1 1/4" diameter; 9/16" high; mounting plate: .064" thick aluminum, 1 3/8" wide, 2 5/32" long, saddle type; 8 contact receptacles.	Tube socket for tubes V-103, V-104 and V-105.	5	9K103955
X-103	R16-S-6188-5	SOCKET, TUBE: steatite body; 1 1/4" diameter, 9/16" high; mounting plate: .064" thick aluminum, 1 3/8" wide, 2 5/32" long, saddle type; 8 contact receptacles.	Tube sockets for tubes V-101, V-102 and V-108.	5	9K103956

TABLE OF REPLACEABLE PARTS  
MODEL: Radio Receiving Equipment AN/APR-1 and AN/SPR-1

MAJOR UNIT: Rectifier PP-10/APR-1

Reference Symbol	Navy Stock No.	Name of Part and Description	Function	Mfr. and Desig. or AWS Type	Cont. or Gov't Dwg. or Spec. No.
A-201		ASSEMBLY, POWER SUPPLY CHASSIS AND BRACE: composed of power supply chassis A-203, cowl fastener spring A-208, rivet H-210, power supply chassis brace A-202, rivet H-209, and screw H-211.	Chassis for parts mounting.	1	1X48524
A-202		BRACE, POWER SUPPLY CHASSIS: overall dimensions: 5.625" long, 1.745" wide, 2 1/32" high; U-shaped; aluminum, lacquered.	Power supply chassis brace.	1	7B48533
A-203		CHASSIS, POWER SUPPLY: aluminum, lacquered; .064" thick, 5.75" wide, 9.437" long, 1.75" high; punched for parts mounting.	Parts mounting.	1	27C48579
A-204		CLAMP, CABLE: cold rolled steel, cadmium plated; hook shaped; .035" thick, 3/8" wide, 3/4" long; .170" diameter for mounting.	Fasten cables to chassis.	1	42A22634
A-205		CLAMP, MOUNTING: cold rolled steel, cadmium plated; 1 1/8" inside diameter, ends flanged; 6-32 thread square nut on one flange; 2 holes .156" diameter on each flange; 2 mounting lugs, L-shaped, 5/32" hole.	Mount capacitors C-202 and C-203.	1	42A52140
A-206		SLEEVE, RUBBER: 5/16" outside diameter, 1/4" inside diameter, 1/2" long; black.	Cable protector.	6 18	37K48498
A-207		SPACER: I.F. COIL: same as A-103.	Mount terminal strips.		
A-208		SPRING, COWL FASTENER: floating; overall dimensions: 1 3/8" long, 1" wide, 9/32" high; 2 mounting holes .128" diameter; cold rolled steel, cadmium plate finish.	Dust cover retainer.	1	41A48808
A-209		TERMINAL STRIP: phenolic, grade XX; 3/32" thick, 5/8" wide, 3.187" long, 2 holes .156" diameter for mounting; 7 solder terminals.	Tie point.	13	31A52166
A-210		CLAMP, TUBE: same as A-102.	Tube clamp.		
C-201	R16-C-9692-25	CAPACITOR, ELECTROLYTIC: 50 microfarads - 10% + 20%; 50 V. D-C working; 2 mounting lugs with .187" diameter holes; 3/8" long; insulating terminals marked red and black; 1 3/4" long, 1" wide, 1/8" high.	Filter.	16 BS-39	23A48624
C-202	R16-C-9678-50-100	CAPACITOR, PLUG-IN ELECTROLYTIC: 4 pin capacitor; electrical specifications: Pin #1, common negative, Pin #3, 20 microfarads + 50% - 10%, 350 V. D-C working; Pin #5, 20 microfarads + 50% - 10%, 150 V. D-C working; Pin #7, dummy; inclosed in aluminum can: 4 1/4" long, 1 3/8" diameter.	Filter.	30	23B48627
C-203		CAPACITOR, PLUG-IN ELECTROLYTIC: same as C-202.	Filter.		
E-201		LUG, SOLDERING: same as E-103.	Tie point.		
H-201		GROMMET: rubber, 9/16" outside diameter, 9/32" inside diameter, 1/4" thick, 1/16" wide groove along edge.	Cable lead protector.	6	37A17361
H-202		LOCK WASHER: same as H-101.	General.		
H-203		LOCK WASHER: #10, external, 13/32" outside diameter, .195", .204" inside diameter, .020" thick; spring steel, white cadmium finish.	For 10-32 screws.	22 #1110	457652

TABLE OF REPLACEABLE PARTS  
MODEL: Radio Receiving Equipment AN / APR-1 and AN / SPR-1

MAJOR UNIT: Rectifier PP-10 / APR-1

Reference Symbol	Navy Stock No.	Name of Part and Description	Function	Mfr. and Desig. or AWS Type	Cont. or Gov't Dwg. or Spec. No.
H-204		LOCKWASHER: #8 external, 3/8" outside diameter, .168-.176" inside diameter, .018" thick; spring steel, white cadmium finish.	For 8-32 screws.	22 #1108	4S7657
H-205		NUT: same as H-102.	Parts mounting.		
H-206	R16-GV-2S8363	NUT: 6-32 thread, 1/4" diameter, hexagonal, 3/32" thick; brass, white nickel finish.	Parts mounting.	26	2S8363
H-207		NUT: 10-32 thread, 3/8" long, 1/8" thick; hexagonal; brass, white nickel plated.	For 10-32 screws.	26	2S8370
H-208		NUT: 8-32 thread, 5/16" diameter across flat, 1/8" thick; hexagonal brass, white nickel finish.	For 8-32 screws.	26	2S8369
H-209		RIVET: body: 7/32" long, .125" diameter; head: .216" diameter, .042" thick, aluminum.	Fasten brace to power supply chassis.	7	5A48771
H-210		RIVET: 3/16" diameter, .122" long, flat head; brass; polished nickel finish.	Mount cowl fastener spring H210.	7	5S7701
H-211		SCREW: 6-32 thread, 3/8" long; slotted flat head machine screw, white nickel finish.	Assemble chassis.	26	3S1250
H-212		SCREW: 8-32 thread, 3/8" long; slotted binder head machine screw; brass, white nickel finish.	Assemble chassis.	26	3S8034
H-213		SCREW: same as H-103.	Parts mounting.		
H-214		SCREW: 6-32 thread, 5/16" long; slotted binder head; brass; white nickel finish.	Parts mounting.	26	3S1229
H-215		SCREW: same as H-104.	Parts mounting.		
H-216		SCREW: 6-32 thread, 7/16" long, slotted binderhead; brass, white nickel finish.	Parts mounting.	26	3S1252
H-217		SCREW: 6-32 thread, 5/8" long; slotted binderhead; brass, white nickel finish.	Parts mounting.	26	3S1253
L-201 L-202 L-203	R16-GV-25B48670	PACK "B" CHOKE (3 SECTION): section A: core, #24 Birmingham gauge radio No. 2, laminations interleaved 9 x 9; shell stack, 5/16" wide, 3/8" high; center leg, 7/8" wide; 3/8" high; window, 5/16" wide, 5/8" long; periphery: 1 1/4" wide, 1 7/8" long; coil form, 3 layers .007" gummied Kraft paper; 2770 turns #34 A.W.G. solid enameled copper wire; winding resistance: 230 ohms -10% +0%; inductance: 7 henries at .060 amperes; terminals 3 and 4, connected in series to section B.	Input filter; B+ filter, output filter, for tuner.	8	25B48670



TABLE OF REPLACEABLE PARTS

MODEL: Radio Receiving Equipment AN/APR-1 and AN/SPR-1

MAJOR UNIT: Rectifier PP-10/APR-1

Reference Symbol	Navy Stock No.	Name of Part and Description	Function	Mfr. and Desig. or AWS Type	Cont. or Gov't Dwg. or Spec. No.
R-201	R16-R-17318-10	SECTION B: core, #24 Birmingham gauge radio No. 2; shell stack, $\frac{5}{16}$ " wide, $\frac{5}{16}$ " high; center leg, $\frac{7}{8}$ " wide, $\frac{5}{16}$ " high; window, $\frac{5}{16}$ " wide, $1\frac{1}{16}$ " long; periphery, $1\frac{9}{16}$ " wide, $1\frac{7}{8}$ " long; air gap, .005" fibre; coil form, 3 layers .007" gummed Kraft paper; 3037 turns #35 A.W.G. solid enameled copper wire; winding resistance, 302 ohms $-10\%$ $+0\%$ ; inductance, 7 henries at .060 amps; terminals 4 and 5, connected in series to section A.  SECTION C: core #24 Birmingham gauge radio No. 2; shell stack, $\frac{7}{16}$ " wide, $\frac{7}{16}$ " high; center leg, $\frac{7}{8}$ " wide, $\frac{7}{16}$ " high; window, $\frac{7}{16}$ " wide, $1\frac{1}{16}$ " long; periphery $1\frac{7}{8}$ " wide, $2\frac{5}{8}$ " long; air gap, .007" fibre; coil form, 3 layers .010" gummed Kraft paper; 2554 turns of #31 A.W.G. solid enameled copper wire; winding resistance, 150 ohms $-10\%$ $+0\%$ ; inductance, 6 henries at .100 amperes; terminals 1 and 2; paper insulation between and over windings; terminals securely anchored at bottom to provide vacuum seal; potting compound, #X115 bi-wax; metal case hot tinned dipped and lacquered; overall dimensions: $3\frac{5}{8}$ " wide, $3\frac{5}{16}$ " long, $4\frac{5}{16}$ " high; 4 #10-32 thread class 2 fit mounting studs for mounting to chassis.	Bleeder.	27	17A48767
T-201	R16-GV-25C48677	RESISTOR: fixed; porcelain tube, wire-wound; 25,000 ohms $\pm 5\%$ ; 10 watts; insulated; tube, $1\frac{13}{32}$ " outside diameter, $1\frac{3}{4}$ " long; #18 tinned copper radial leads, $11\frac{1}{16}$ " long.  TRANSFORMER, POWER: core: #29 U.S. standard gauge radio #4 iron interleaved, center leg $1\frac{1}{2}$ " x $1\frac{1}{2}$ ", shell stack, $\frac{1}{2}$ " wide x $\frac{1}{8}$ " high, window $\frac{1}{2}$ " wide x $\frac{1}{8}$ " high, periphery $1.25$ " wide x $2$ " long x $3.9$ " long x $3.2$ " wide; gummed Kraft paper coil form; secondary #1 winding; 1470 turns of #35 A.W.G. enameled copper wire tapped at 755 turns, terminals 1-2-3; secondary #2 winding; 828 turns of #31 A.W.G. solid enameled copper wire tapped at 414 turns, terminals 4-5-6; winding #3 (part of secondary #3): $13\frac{1}{2}$ turns of 2 strand #17 A.W.G. solid enameled copper wire, terminals 7-8, winding #3 and #5 are connected in parallel; winding #4 (part of primary:) $159\frac{1}{2}$ turns of #19 A.W.G. solid enameled copper wire, terminals 9-10, winding #4 (terminal #10) connected series with winding #6; winding #5 (secondary #3): $13\frac{1}{2}$ turns of 2-strand #17 A.W.G. solid enameled copper wire, terminals #7-8 winding #5 and #3 connected in parallel; winding #6 (part of primary): 69 turns of #21 A.W.G. solid enameled copper wire, terminals #10-11, windings #6 (terminal #10) connected in series with winding #4, winding #7 (secondary #4) 11 turns of #17 A.W.G. solid enameled copper wire, terminals #14-#15; winding #8 (secondary #5): 11 turns of #17 A.W.G. solid enameled copper wire, terminal #12-13; paper insulation between and over windings; petrocene B wax impregnated; #X118 bi-wax potting compound; insulated terminal lugs; metal case: $4\frac{3}{16}$ " wide, $4\frac{33}{64}$ " long, $5\frac{1}{4}$ " high; 4 mounting studs threaded 10-32.	Power Transformer.	8	25C48677

TABLE OF REPLACEABLE PARTS  
MODEL: Radio Receiving Equipment AN/APR-1 and AN/SPR-1

MAJOR UNIT: Rectifier PP-10/APR-1

Reference Symbol	Navy Stock No.	Name of Part and Description	Function	Mfr. and Desig. or AWS Type	Cont. or Gov't Dwg. or Spec. No.
V-201	16-T-55735	RADIO TUBE: full wave, high vacuum rectifier of the filament type, octal base, glass.	Rectifier.	14	5Y3GT/G
V-202		RADIO TUBE: same as V-201.	Rectifier.		
X-201		SOCKET, TUBE: same as X-101.	Tube socket for tubes V-201 & V-202, capacitor C-202 and C-203.		

TABLE OF REPLACEABLE PARTS

MODEL: Radio Receiving Equipment AN/APR-1 and AN SPR-1

MAJOR UNIT: Chassis Base MX-24/APR-1

Reference Symbol	Navy Stock No.	Name of Part and Description	Function	Mfr. and Desig. or AWS Type	Cont. or Gov't Dug. or Spec. No.
A-301	R16-GV-66A52139	ASSEMBLY, ALIGNMENT TOOL: phenolic handle, 7/16" diameter, 5" long; wrench: cold rolled steel cadmium plated, .1925" inside diameter hexagonal, 5/32" deep, 5/16" outside diameter, 1/4" long head, stud 1/2" long, .1835" diameter, stainless steel retainer pin.	I. F. coil alignment.	1	66A52139
A-302		ASSEMBLY, BRACKET AND GUSSET PLATES: composed of reinforcing bracket A-312, gusset plates A-321, and rivets H-324.	Reinforce chassis.	1	1X48521
A-303		ASSEMBLY, GUIDE RAIL AND SPRING (BOTTOM): composed of guide rail A-322, stud A-330, and loading springs A-329.	Tuning unit guide rail.	1	1X48505
A-304		ASSEMBLY, GUIDE RAIL AND SPRING (TOP): composed of guide rail A-323, stud A-330, and loading springs A-329.	Tuning unit guide rail.	1	1X48504
A-305		ASSEMBLY, LEFT FRAME BRACKET AND BUSHING: composed of chassis frame A-316, frame alignment pin bracket A-309.	Chassis support.	1	1X48522
A-306		ASSEMBLY, RIGHT FRAME BRACKET AND BUSHING: composed of chassis frame A-318, frame alignment pin bracket A-310, and rivet H-324.	Chassis support.	1	1X48523
A-307		ASSEMBLY, TUNER HOUSING AND BUSHING: composed of tuner housing and gussets A-319 and bushings A-314.	Housing for tuning units.	1	1X48501
A-308		BRACKET, CHASSIS REINFORCING: aluminum, lacquered; triangular shaped; side flanges; 3/16" long side; 1 hole .196" diameter and 1 hole .187" diameter for mounting on flanges.	Reinforce front panel and chassis mounting.	1	7A48569
A-309		BRACKET, FRAME ALIGNMENT PIN (LEFT): stainless steel, lacquered; L-shaped, .062" thick, 1/2" wide, 1 1/16" long; 2 holes .136" diameter, 1 hole .195" diameter, 1 hole .187" diameter.	Corner bracket for chassis.	1	7A48536
A-310		BRACKET, FRAME ALIGNMENT PIN (RIGHT): stainless steel, lacquered, .062" thick, 1/2" wide, 1 1/16" long.	Corner bracket for chassis.	1	7A48567
A-311	R16-GV-7A48530	BRACKET, HOLD-DOWN: stainless steel; L-shaped; .075" thick, 1 1/8" long, 1/4" projection; 2 holes .180" diameter for mounting; black enamel finish, except projection.	Mount receiver in shock mount.	1	7A48530
A-312		BRACKET, REINFORCING: aluminum, lacquered; .064" thick, 9.812" long, 4 1/16" high; top and bottom flanged, punched for ventilation and mounting.	Reinforce chassis.	1	7C60795
A-313		BRACKET, RESISTOR MOUNTING: cold rolled steel, white nickel plated, L-shaped; 5/16" wide, 3/4" long, 7/16" high; 2 holes .140" diameter.	Mount resistor R-201.	1	7A48779
A-314		BUSHING: stainless steel; tapped 4-40 thread; overall dimensions: .250" square, .250" high; mounting stud: .216" outside diameter, .178" inside diameter, tapered edge, .083" high.	Mount tuner housing to front panel.	1	43K60783
A-315		BUTTON, PLUG: steel, cadmium plated; 7/8" diameter, 5/64" high, 12/64" long, prong fasteners.	Cover for cable fitting nut.	1	38A48543

TABLE OF REPLACEABLE PARTS

MODEL: Radio Receiving Equipment AN/APR-1 and AN/SPR-1

MAJOR UNIT: Chassis Base MX-24/APR-1

Reference Symbol	Navy Stock No.	Name of Part and Description	Function	Mfr. and Desig. or AWS Type	Cont. or Gov't Dwg. or Spec. No.
A-316		CHASSIS FRAME (LEFT): alum'num, lacquered; overall dimensions: .064" thick, 4 1/8" high at one end, 1 7/8" high at other end, 19 11/16" long; ends flanged 1/2" wide; punched for ventilation and parts mounting.	Chassis support.	1	15D60798
A-317		CLAMP, CABLE: same as A-204.	Cable clamp.		
A-318		FRAME, CHASSIS (RIGHT): aluminum, lacquered; .064" long, 1 7/8" wide at one end, 4 1/8" wide at other end, 8 1/16" long, ends flanged 1/2" wide; punched for ventilation and parts mounting.	Frame for chassis mounting.	1	15C60797
A-319		HOUSING, TUNER, AND GUSSET: aluminum, lacquered; .064" thick, 7 1/16" high, 5 15/16" wide, 10 21/32" long; punched for ventilation and parts mounting; four gussets for corner reinforcement.	Housing for tuning units.	1	64C60794
A-320		PANEL, FRONT: aluminum, black wrinkle finish on front, lacquered on back; .125" thick, 10 1/4" wide, 7 27/32" high; punched for parts mounting.	Control panel.	1	64A48564
A-321		PLATE, GUSSET: aluminum, lacquered; triangular shape; center raised; 3" base, 2 3/8" long, 2 holes .195" diameter for mounting, 2 holes .128" diameter for bracket mounting.	Reinforce chassis.	1	64A60786
A-322		RAIL, GUIDE AND BUSHING (BOTTOM): stainless steel, lacquered; U-shaped .042" thick, 10 17/32" long, 1" wide, 1/2" high; 2 holes .187" diameter for mounting, 3 holes .128" diameter for spring mounting.	Tuning unit guide rail.	1	7B60789
A-323		RAIL, GUIDE AND BUSHING (TOP): stainless steel, lacquered; U-shaped; .042" thick, 10 17/32" long, 1" wide, 1/2" high; 2 holes .187" diameter for mounting; 3 holes .128" diameter for spring mounting.	Tuning unit guide rail.	1	7B60802
A-324		RAIL, MOUNTING AND BUSHING (BOTTOM): stainless steel, lacquered; U-shaped; .062" thick, 5 3/4" long, 1 1/16" high, 3/8" wide; 1 hole .218" diameter; 2 bushings tapped 6-32 thread, 5/16" square, 3/16" high.	Mount bottom guide rail.	1	7B60788
A-325		RAIL, MOUNTING AND BUSHINGS (TOP): stainless steel, lacquered; U-shaped; .062" thick, 5 3/4" long, 1 1/16" high, 3/8" wide; 1 hole .218" diameter; 2 bushings tapped 6-32 thread, 5/16" square, 3/16" high.	Mount top guide rail.	1	7B60799
A-326		SLEEVE, RUBBER: same as A-206.	Cable clamp bumper.		
A-328		SPRING: phosphor bronze, white nickel plated; .062" thick, 3/8" wide, 2 1/16" long, 2 holes .1925" diameter.	Dust cover tension spring.	1	41A48592
A-329		SPRING, LOADING: phosphor bronze, white nickel plated; .015" thick, 1/4" wide, 39/16" long; 2 holes .128" diameter; forms 1 1/16" loop.	Guide rail spring.	1	41A60785
A-330		STUD: stainless steel; 1/2" outside diameter, .534" high, tapped 8-32 thread, .183" diameter x .083" high mounting stud.	Mount rail guide.	1	46A60784
A-331		CHEST, spare parts: CRS; gray enamel; empty 2.4.048" lg. x 12.048" wd. x 9.048" high overall; has five (5) compartments; has two (2) handles, folding type on ends; White Way Electric #PRO. 261; (hasp for padlock on cover).	Holder spare parts.	57 #PRO. 261	15D104716

TABLE OF REPLACEABLE PARTS

MAJOR UNIT: Chassis Base MX-24 / APR-1

MODEL: Radio Receiving Equipment AN/APR-1 and AN/SPR-1

Reference Symbol	Navy Stock No.	Name of Part and Description	Function	Mfr. and Desig. or AWS Type	Cont. or Gov't Draw. or Spec. No.
E-301		ASSEMBLY, SHELL AND BUSHING: composed of hood E-313 and cable fitting bushing E-303.	Panoramascopereceptacle.	1	28K42125
E-302		BLOCK, TERMINAL: phenolic, grade XX; 3/16" thick, 1 1/2" wide, 2 3/8" long; 4 holes .156" diameter for mounting; 3 holes .144" diameter for plug mounting.	Mount power plugs.	1	46A60780
E-303		BUSHING, CABLE FITTING: brass, silver plated; 19/32" long, .360" diameter; tapered and threaded 5/16-32; 1.143" diameter hole.	Panoramascopereceptacle and video receptacle cable bushing.	1	43A52160
E-304		BUSHING, CABLE FITTING: brass, silver plated; upper collar: .475" diameter, 1/8" thick; lower collar: .575" diameter tapered and slotted, 5/32" thick; body center: .218" diam., 1/8" long.	Antenna co-axial cable bushing.	17	43A52164
E-305		BUSHING, RECEPTACLE: brass, silver plated; 3/4-20 thread, 19/32" long, .564" hole.	Part of antenna receptacle assembly E-320.	17	43A52153
E-306		BUSHING, RECEPTACLE: brass, silver plated; collar: 1/4" diameter, hexagonal, 5/32" thick; body: .156" diameter, 7/32" long; tapped 6-32 thread.	Part of female receptacle E-320 and X-303.	17	43A52148
E-307		BUSHING, RECEPTACLE: brass, silver plated; collar: 7/8" diameter hexagonal, 1/8" thick; body: 3/4"-20 thread, 15/32" long; .564" diameter hole.	Part of female receptacle S-101.	17	43A52176
E-308		CABLE, COAXIAL (LONG): #18 solid bare copper wire; 3/64" wall, copolene insulation shielded with seamless copper tubing, silver plated; 16" long, bent to fit mounting location.	Antenna lead-in cable.	1	30B48545
E-309		CABLE, COAXIAL (MEDIUM): #18 solid bare copper wire; 3/64" wall, copolene insulation shielded with seamless copper tubing, silver plated; 10" long, bent to fit mounting location.	Panoramascopereceptacle adapter lead-in.	1	30B48546
E-310		CABLE, COAXIAL (SHORT): #18 solid bare copper wire; 3/64" wall, copolene insulation shielded with seamless copper tubing, silver plated; 8" long, bent to fit mounting location.	Panoramascopereceptacle cable.	1	30B48547
E-311		CONTACT, RECEPTACLE: brass, silver plated; 15/16" long, 1/4" diameter, counterbored 5/8" deep, .171" diameter; stud end 6-32 thread, 1/4" long; hexagonal at upper end.	Part of female receptacles E-320 and X-303.	17	39A52146
E-312	R17-P-7195	HOLDER, FUSE: molded phenolic, black; spring contact at base; screw contact at top; 1 3/4" long, 1/2" diameter, 1/2-24 thread for mounting.	Receptacle for fuse.	15 #1212-B	65A48728
E-313		HOOD, BRASS: silver plated; 1 1/2" thick, 1" square mounting plate; 3/4" long overall; 4 holes. 125" diameter for mounting.	Panoramascopereceptacle hood.	5 #83-1H	15A48299
E-314		INSULATOR, RECEPTACLE: formica MF or linen bakelite XX, wax impregnated; 23/32" wide, 7/8" long, .500" high; 3 holes .156" diameter; counterbored 3/16" deep, 13/32" diameter.	Part of female receptacles E-320 and X-303.	17	14A52150
E-315		KNOB, CONTROL: bakelite, knurled edge; 1" diameter, 9/16" high; brass bushing .251" inside diameter; 2 holes tapped 8-32 thread for 2 set screws 8-32 thread 5/16" long.	Gain control knob.	1	36A102411

TABLE OF REPLACEABLE PARTS  
MODEL: Radio Receiving Equipment AN/APR-1 and AN/SPR-1 MAJOR UNIT: Chassis Base MX-24/APR-1

Reference Symbol	Navy Stock No.	Name of Part and Description	Function	Mfr. and Desig. or AWS Type	Cont. or Gov't Dwg. or Spec. No.
E-316	R16-L-12932-270	LIGHT SOCKET AND JEWEL: mounts pilot light and red indicator lens; overall dimensions: 2 1/4" long, 15/16" diameter; external parts black nickel finish, internal parts white cadmium plated.	Indicates operation of set.	11 #80	60A42288
E-317		LUG, SOLDERING: copper, hot tinned; .015" thick; .093" diameter wire hole, .109" diameter mounting hole; plain flat type.	Power plug, ground lug.	29 #7	29K5346
E-318		PLUG ASSEMBLY, CHASSIS: brass, silver plated; 5/8-24 thread on upper and lower ends; contact pin in center; 17/16" long overall; 1" square mounting plate, 3/32" thick; 4 holes .125" diameter; clamping nut, 3/4" outside diameter, 1/2" high, tapped 5/8-24 thread.	Antenna receptacle plug.	20 #JNPT-5-2	9A42053
E-319		PLUG, BANANA: brass mounting stud, phosphor bronze contact springs, silver plated; overall dimensions: 1 3/16" long, 3/8" diameter.	Power plug.	1	29X52356
E-320	R16-GV-9A52155	RECEPTACLE, FEMALE: composed of receptacle shell E-321, receptacle insulator E-314, receptacle contact E-311, lockwasher H-311, receptacle bushing E-306, receptacle bushing E-305, and nut H-319.	Antenna receptacle for tuning unit.	17	9A52155
E-321		SHELL, RECEPTACLE: brass, silver plated; .553" outside diameter, .500" inside diameter, 1 3/8" long.	Part of female receptacles E-320 and X-303.	17	15A52151
E-322		ASSEMBLY, CABLE AND RECEPTACLE (SHORT): composed of: coaxial cable E-309, chassis receptacle X-301, cable fitting bushing E-303, brass hood E-313, and cable fitting nut H-318.	Panoramoscope cable.	1	1X103608
E-323		ASSEMBLY, CABLE AND RECEPTACLE (MEDIUM): composed of: coaxial cable E-309, chassis receptacle X-301, cable fitting bushing E-303, brass hood E-313, and cable fitting nut H-318.	Panoramoscope adapter lead-in.	1	1X103607
E-324		ASSEMBLY, CABLE AND RECEPTACLE (LONG): composed of: coaxial cable E-308, chassis plug assembly E-318, and cable fitting bushing E-304.	Antenna lead-in.	1	1X103606
E-325		ASSEMBLY, POWER SUPPLY LACED CABLE: composed of: 21" #18 strand Arglas, white and black wire, 11 1/2" #22 strand Arglas, white and yellow wire; 10 1/2" #22 strand Arglas, white, black and red wire, 9" #22 strand white, black and orange wire, 13" #22 strand Arglas, white, black and brown wire, 8" #22 strand Arglas, white, black and yellow wire, 14" #18 strand Arglas white wire, 14" #22 strand Arglas white and brown wire, and 25" lacing twine.	Power supply wiring cable.	1	1X48527
E-326		ASSEMBLY, RECTIFIER: PP-10 AN/SPR-1; 5.187" wide x 7.250" high x 10.250" long, complete, less tubes.	Power supply.	1	1D48525
F-301	R17-F-14285	FUSE: glass encased, 1 1/4" long, 1/4" diameter, 5 amperes. (2 spares mounted on Chassis Base MX-24/APR-1.)	Circuit breaker.	15 4AG	65X81441
H-301		BUSHING, CABLE FITTING: brass, silver plated; overall dimensions: 19/32" long, 7/16" diameter across hexagonal collar; tapered end; both ends 5/16-32 thread; .143" diameter hole.	Mount antenna tube to antenna female receptacle.	1	43A52156

TABLE OF REPLACEABLE PARTS  
MODEL: Radio Receiving Equipment AN/APR-1 and AN/SPR-1

MAJOR UNIT: Chassis Base MX-24/APR-1

Reference Symbol	Navy Stock No.	Name of Part and Description	Function	Mfr. and Desig. or AWS Type	Cont. or Gov't Desig. or Spec. No.
H-302		CLIP; phosphor, bronze; nickel plated; .031" thick; overall dimensions: 2 1/16" long, 3/8" high, 5/32" diameter hole in center for mounting to chassis.	Allen wrench holder.	1	42A48491
H-303		CLIP, FUSE: phosphor bronze; nickel plated; 9/16" high, 3/8" wide, 13/32" long; .171" diameter mounting hole.	Mount spare fuses.	15 #1319	42A81194
H-304		CLIP, FUSE: phosphor bronze; nickel plated; 7/16" high, 11/32" wide, 7/16" long; .1365" diameter mounting hole.	Mount spare pilot lights.	1	42A31278
H-305	R16-GV-55A48596	HANDLE, CHASSIS: aluminum die cast, black anodize finish; 4.250" between mounting holes, 1 3/8" high, 2 holes tapped 8-32 thread, 5/8" deep for mounting.	Carrying handle.	1	55A48596
H-306		LOCK WASHER: 3/4" internal; 1 1/4" outside diameter; .768"-.790" inside diameter; .050" thick; spring steel; white cadmium finish.	Part of antenna and I. F. female receptacles.	22 #1232	4S7664
H-307		LOCK WASHER: #4 internal, 17/64" outside diameter; .018" thick; spring steel; white cadmium finish.	General.	22 #1204	4S7683
H-308		LOCK WASHER: #8 external, 3/8" outside diameter, .168"-.176" inside diameter, .018" thick; spring steel, white cadmium finish.	Mount guide rail and bracket.	22 #1108	4S7657
H-309		LOCK WASHER: #6 internal, 9/32" outside diameter, .142"-.150" inside diameter, .018" stock thickness, spring steel, white cadmium finish.	Power plug washer.	22 #1206	4S7650
H-310		LOCK WASHER: same as H-101.	Fasten mounting plate.		
H-311		LOCK WASHER: #6, split, 2 1/64" outside diameter; .140"-.151" inside diameter, 3/64" x .062" thick; phosphor bronze, white nickel finish.	Part of female receptacles E-320 and X-303.	17	4S8431
H-312		LOCK WASHER: 3/8" internal, 1 1/16" outside diameter, .384"-.398" inside diameter, .035" thick; spring steel, white cadmium finish.	Mount audio jack.	22 #1220	4S7655
H-313		LOCK WASHER: #8 internal, 3/16" outside diameter, spring steel, white cadmium finish.	Mount hold-down bracket.	22 #1208	4S7651
H-314		LOCK WASHER: #4 internal, 17/64" outside diameter; spring steel, black nickel finish.	Mount meter.	22 #1204	4S8414
H-315		LOCK WASHER: 15/32" inside diameter, internal; spring steel, white nickel finish.	Mount switches.	22	4S8424
H-316		NUT: same as H-102.	Fasten mounting plate.		
H-317		NUT: 4-40 thread, 1/4" wide, 3/32" thick; hexagonal; brass, white nickel finish.	For 4-40 screws.	26	2S8362
H-318		NUT, CABLE FITTING: 5/16-.32 thread; overall dimensions: 7/16" diameter across hexagonal flats; .375" outside diameter of collar; 3/32" thickness of collar, brass; silver plate finish.	Fasten antenna tube to antenna bushing and panoramascope video coaxial cable.	1	2A52158
H-319		NUT: 3/4-20 thread; 7/8" diameter across flats; 5/32" thick; hexagonal; brass, silver plated finish.	Mount antenna and I. F. female receptacles.	17	2A48539

TABLE OF REPLACEABLE PARTS  
MODEL: Radio Receiving Equipment AN/APR-1 and AN/SPR-1 MAJOR UNIT: Chassis Base MX-24/APR-1

Reference Symbol	Navy Stock No.	Name of Part and Description	Function	Mfr. and Desig. or AWS Type	Cont. or Gov't Dwg. or Spec. No.
H-320		NUT, CABLE FITTING: 1 hole tapped 5/16-32 thread, 1 hole 3/4-20 thread; overall dimensions: 1" diameter, hexagonal, 1/2" thick; brass, silver plate finish.	Mount antenna cable bushing.	1	2A52162
H-321		NUT: same as H-208.	Mount guide rail.		
H-323		RIVET: 3/32" long, .083" diameter body; flat head, cold rolled steel, nickel finish.	Mount guide rail springs.	24	5X52522
H-324		RIVET: aluminum; countersunk flat head; 7/32" long, .125" diameter, .216" diameter head.	Mount gusset plates and fasten frame bracket.	7	5A48771
H-325		RIVET: 7/32" long, .122" diameter; cold rolled steel, polished nickel finish.	Mount fuse and wrench clips.	7 24	5S7703
H-326		RIVET: brass, flat head; .088" diameter, 7/32" long, black nickel plated.	Mount speed-nuts.	24	5S6832
H-327		RIVET: 3/16" long, .180" diameter; cold rolled steel, polished nickel finish.	Mount dust cover springs.	24 S524-4	5S7705
H-328		SCREW: same as H-211.	Mount guide rails.		
H-329		SCREW: same as H-212.	General.		
H-330		SCREW: 4-40 thread, 3/8" long; slotted flat head; brass, black nickel finish.	Mount panoramscope, video, antenna receptacles, power plug and front panel.	26	3S1228
H-331		SCREW: 8-32 thread, 5/16" long; slotted binderhead machine screw; brass, white nickel finish.	Mount guide rail.	26	3S1251
H-332		SCREW: 8-32 thread, 7/16" long; slotter binderhead; brass, white nickel finish.	Assemble chassis.	26	3S1260
H-333		SCREW: 6-32 thread; 5/16" long; slotted flat head; brass; white nickel finish.	Mount coaxial cable clamp.	26	3S1242
H-334		SCREW: 6-32 thread: 1/4" long; slotted binderhead machine screw; cold rolled steel; white nickel finish.	Mount clamp for plug lead.	26	3S8031
H-335		SCREW: 4-40 thread, 1/2" long; slotted binderhead; brass, black nickel finish.	Mount meter.	26	3S1222
H-336		SCREW: 6-32 thread, 2 1/4" long, slotted round head; cold rolled steel, white nickel plated.	Mount resistor R-201.	26	3S1249
H-337		SPEEDNUT: cold rolled steel, white nickel plated; 5/8" long, 1/4" wide; 3/64" thick; tapped 4-40 thread.	Mount meter, I-302.	25 #6177-4-40	2S7975
H-338		SCREW: 8-32 thread, 1/2" long; slotted binderhead; brass, white nickel finish.	Mount reinforcing bracket and handle.	26	3S6980
H-339		SCREW: 4-40 thread, 7/16" long; slotted flat head; brass, white nickel finish.	Mount chassis power plug and soldering lug.	26	3S1254



TABLE OF REPLACEABLE PARTS

MODEL: Radio Receiving Equipment AN/APR-1 and AN/SPR-1 MAJOR UNIT: Chassis Base MX-24/APR-1

Reference Symbol	Navy Stock No.	Name of Part and Description	Function	Mfr. and Desig. or AWS Type	Cont. or Gov't Dwg. or Spec. No.
H-340		SCREW: 8-32 thread, 1/2" long; slotted binderhead; brass, black nickel finish.	Mount hold-down bracket.	26	3S1269
H-341		SCREW: 8-32 thread, 7/16" long; slotted flat head; brass, white nickel finish.	Chassis assembly.	26	3S1240
H-342		SCREW: same as H-216.	Fasten mounting plate.		
H-344		WASHER, INSULATING: phenolic, grade XXP; .093" thick, 11/32" outside diameter, .144" diameter hole.	Insulator for resistor R-201.	1	4A48783
H-345		WRENCH, ALLEN "L": .063" diameter; hexagonal; 3/4" wide, 23/16" long.	Mount knobs.	1	66A106513
H-346		WRENCH, ALLEN "L": 5/64" diameter; hexagonal; 7/8" wide, 2 1/4" long.	Mount knobs.	1	66A106514
H-347		NUT: 15/32" thread, 9/16" outside diameter, hexagonal, 3/32" thick; steel, black, nickel plated.	Mount toggle switches.	26	2S8381
H-348		LOCKWASHER: 15/32" inside diameter, internal; spring steel, black nickel plated.	Mount toggle switches.	22	4S9727
H-349		PIN, cowl fastener: steel; cadmium plated; 1.437" long x .093" diameter; Shake Proof #98-5-CP (has spline on shank .187" long in center of shank).	Fasten receiver cover.	22	47A48208
H-350		STUD: cowl fastener; cadmium plated; steel; .671" long x .562" diameter; Shake Proof #98-03-513 (has .096" diameter hole for pin .345" from head; screwdriver slotted head).	Fasten receiver cover to chassis.	22	46A42676
J-301		BULB: glass, 6-8 volt; bayonet type base. (2 spares mounted on Chassis Base MX-24/APR-1.)	Operator indicator.	28 47	65X48499
J-310	16-J-3125	JACK: 2 contact, open circuit; 3/8-32 thread, 9/32" long mounting stud; mounting stud and nut black nickel finish.	Audio jack.	27 #ST1048	40A48699
J-302		JACK: same as J-301.	Audio jack.		
J-303	2Z7226-230.1	CONNECTOR, female contact: Army Navy receptacle #AN-3108-22-4S (102); 4 round female contacts, polarized; angle type 90°; 2.937" long x 1.594" wide x 1.969" high overall; Amphenol #AN-3108-22-4S (102) (90° elbow shaped aluminum body, sandblast finish; black molded bakelite insert; take .750" diameter conduit; coupling ring threaded 1 3/8"-18).	Power connector.	5	9B42282
J-304	2Z7226-259 Navy Type No. CPH-49190	CONNECTOR, female contact: Sig. C Plug PL-259, Navy CPH-49190; single round female contact, .718" OD x 1.500" long overall; amphenol #83-1SP (Cylindrical die cast zinc body, silver plated; mica filled phenolic insert; cable opening 7/16"-14 thread diameter).	Antenna connector.	5	28A42310
M-301	R16-M-2107-500	METER: full scale deflection current to be 200 milli-amperes, ±2%; resistance 1000 ohms ±5%; 40 line scale reading. 0-200 scale length, 1 1/2" minimum; window of negatuck white glass; black bakelite case; overall dimensions: 2 3/32" diameter.	Operating level indicator.	21	52B48742

MODEL: Radio Receiving Equipment AN/APR-1 and AN/SPR-1		MAJOR UNIT: Chassis Base MX-24 / APR-1			
Reference Symbol	Navy Stock No.	Name of Part and Description	Function	Mfr. and Desig. or AWS Type	Cont. or Gov't Dwg. or Spec. No.
O-301		MOUNT, vibration: square; 12 lb. load; 2.375" wide x 2.375" long x 1.062" high; Lord Mfg. Co. #150PM12; (rubber cushion) 1.500" diameter x .625" thick; steel sleeve hole in center .257" diameter; steel holder; four (4) mounting holes .196" diameter on 1.937" c/c).	Shock mount.	58	37K486668
O-302		MOUNT, VIBRATION: square; 10 lb. load; 2.375" wide x 2.375" long x 1.062" high; Lord Mfg. Co. #150PH10; (rubber cushion 1.500" diameter x .625" thick; steel sleeve hole in center .257" diameter; steel holder; four (4) mounting holes .196" diameter on 1.937" c/c).	Shock mount.	58	37K420668
O-303		MOUNT, VIBRATION: square 25 lb. load rating; 2.375" long x 2.375" wide x 1.125" high; U.S. Rubber Co. #5150-C; (rubber cushion 1.250" diameter x .625" diameter; steel sleeve hole .257" diameter through center; has four (4) mounting holes .196" diameter 1.937" c/c).	Shock mount.	59	37B104853
O-304		MOUNT, VIBRATION: square; 45 lb. load rating; 3.000" long x 3.000" wide x 1.500" high overall; Lord Mfg. Co. #200PH; (rubber cushion, 2.000" diameter x 1.000" thick; holder cold rolled steel; cadmium plated; steel center sleeve with .391" diameter hole; four (4) mounting holes .250" diameter on 2.500" mounting c/c).	Shock mount.	58	37B48493
P-301		PLUG, CHASSIS: aluminum shell; mica filled bakelite insulation: 4 pins silver plated; 1 3/8-18 thread on upper end; 1 5/8" long, mounting plate 1 5/8" square, 3/32" thick, 4 holes .120" diameter for mounting.	Power plug.	5	28A42125
P-302		ASSEMBLY, MOUNTING PLATE AND PLUGS: composed of terminal block E-302, banana plugs E-319, and lockwasher H-309.	Tuner power plugs.	1	1X48506
P-303	2Z7390-21 Navy Type No. UG-21/U	CONNECTOR, MALE CONTACT: single round silver plated male contact; straight type; .687" diameter x 1.671" long overall; Reliable Machine #UG-21-U; cylindrical brass body, silver plated; knurled connecting coupling with 5/8"-24 inside thread .375" long; .437" ID cable opening).	Panoramoscope and video connector.	60	28A42049
S-301	R17-S-2825-46	POTENTIOMETER: overall resistance 100 ohms $\pm$ 5%, 3/8 x 3/2 thread, class 2 fit mounting stud; overall dimensions: 1 3/8" long, 1 5/8" diameter including lugs.	Gain control.	1	18A48626
S-301		SWITCH, TOGGLE: single pole, single throw, 1 5/32-32 thread mounting stud; overall dimensions: 1 3/16" long, 1 5/32" wide, 1 9/16" high.	A.V.C. switch.	3	40A42169
S-302		SWITCH, TOGGLE: same as S-301.	Heterotone switch.		
S-303		SWITCH, TOGGLE: same as S-301.	Power switch.		
X-301	R16-R-2502	RECEPTACLE, CHASSIS: aluminum shell, mica filled bakelite insulation; overall dimensions: 1" square, 1 1/16" long; 5/8-24 thread; mounting plate; 1" square, 5/64" thick, 4 holes .120" diameter.	Video receptacle.	5 #83-1R	9A42309
X-302		RECEPTACLE, CHASSIS: same as X-301.	Panoramoscope receptacle.		
X-303	R16-GV-9A60835	RECEPTACLE, FEMALE: composed of receptacle shell E-321, receptacle insulator E-314, receptacle contact E-311, lockwasher H-311, receptacle bushing E-306, and receptacle bushing E-307.	I.F. input receptacle.	17	9A60835

TABLE OF REPLACEABLE PARTS  
MODEL: Radio Receiving Equipment AN/APR-1 and AN/SPR-1

MAJOR UNIT: Tuning Unit TN-3/APR-1

Reference Symbol	Navy Stock No.	Name of Part and Description	Function	Mfr. and Desig. or AWS Type	Cont. or Gov't Dug. or Spec. No.
A-401		ASSEMBLY, HOUSING BUSHING: aluminum; 3/4-20 thread; overall dimensions: 7/8" diameter, .875" high, .3765" diameter hole.	Mount knob shaft and gear.	1	51B60267
A-402		ASSEMBLY, TOP COVER PLATE AND WINDOW: composed of: plate cover (top) A-420; window, top cover A-429; and rivet H-429.	Top cover assembly.	1	1X102435
A-403		ASSEMBLY, TUNER PANEL COVER: composed of: cover, tuner panel A-417; bushing, threaded A-412; washer, spring H-479; cover, tuner adj. screw A-416; rivet, shoulder H-429; assembly, spinner lock O-406; rivet H-427; window, dial A-428; washer H-473; rivet H-426; handle H-402; washer, handle H-476; screw H-462; bracket, hold-down A-408; screw H-460; nut H-413; screw H-459; and nut H-419.	Front panel cover assembly.	1	1X100770
A-404		ASSEMBLY, TUNER PANEL STAKED: Panel: 7.531" long, 6.281" wide; aluminum #24ST, .125" thick; pinion stud: stainless steel, overall dimensions: 1/2" diameter, 1" long, one end tapped 6-32 thread, 1/2" deep; idler gear stud: stainless steel, overall dimensions: 1/2" diameter, 29/32" long; one end tapped 6-32 thread; dial shaft bushing: aluminum, 7/8" diameter, 1 1/32" high, .4365" diameter hole.	Parts mounting.	1	51X100701
A-405		ASSEMBLY, TUNER UNIT HOUSING: composed of: housing tuner A-418; insulator, capacitor E-410; insulator, capacitor E-409; washer, capacitor C-401 and C-402; lug, soldering E-422; lug, soldering E-423; screw H-455; lockwasher H-404; nut H-414; shaft and worm assembly O-404; spacer, bearing and drive shaft O-444; ball bearing O-407; collar, bearing adjustment sleeve O-414; bracket, bearing adjustment A-406; screw H-448; screw H-545; bushing, threaded adjustment O-412; slug, setscrew O-442; setscrew H-453; plate, lockwasher stop O-430; washer O-456; collar, stop O-416; setscrew H-453; plate, bearing retainer A-419; screw H-449; and pin, panel alignment H-424.	Parts mounting.	1	1X100763
A-406		BRACKET, BEARING ADJUSTMENT: stainless steel; "Z" shaped; overall dimensions: 1 1/32" high, 1 1/4" wide; 1 1/8" thick; 1 hole 7/8-40 thread, 2 holes 8-32 thread, 4 holes .116" diameter countersunk.	Bearing retainer.	1	7B60767
A-407		BRACKET, CAM TRACK: cold rolled steel, cadmium plated; overall dimensions: 3 1/8" long, 13/32" high, .345" wide, .032" thick; 2 holes, one on each end, .125" diameter, 9 holes centered, .145" diameter; U-shaped.	Mount cam track spring.	1	7A60932
A-408		BRACKET, HOLD DOWN: same as A-311.	Fasten tuner in shock mount.		
A-409		BUSHING, RECEPTACLE: brass, silver plated; 7/8" hexagonal; 15/16" high; 3/4-20 thread, class 2 fit.	Chassis plug bushing.	1	43A48737
A-410		BRACKET, SPRING RETAINER: cold rolled steel, white cadmium plated; L shaped; 1 leg 23/32" long, containing two .156" diameter holes, 1 leg 1 1/8" long, containing one .156" diameter hole, .053" thick.	Fasten pointer spring.	1	7A60753

TABLE OF REPLACEABLE PARTS  
MODEL: Radio Receiving Equipment AN/APR-1 and AN/SPR-1

MAJOR UNIT: Tuning Unit TN-3/APR-1

Reference Symbol	Navy Stock No.	Name of Part and Description	Function	Mfr. and Desig. or AWS Type	Cont. or Gov't Dwg. or Spec. No.
A-411		BRACKET, SPRING RETAINER: cold rolled steel, white cadmium plated; 1 leg $2\frac{3}{32}$ " long, containing 2 holes .156" diameter, 1 leg $1\frac{1}{16}$ " long containing 1 hole .156" diameter.	Fasten rotor link anti-backlash spring.	1	7K60755
A-412		BUSHING, THREADED: same as A-314.	Mount cover.		
A-413		CLAMP, CABLE: cold rolled steel, white nickel plated; hook shaped; $\frac{3}{8}$ " wide, $\frac{5}{8}$ " long, .033" thick; 1 hole .173" diameter.	Fasten antenna lead-in.	45 #659	42A100764
A-414		CLAMP, CABLE: cold rolled steel; white cadmium plated; overall dimensions: $\frac{5}{8}$ " long, $\frac{3}{8}$ " wide, .033" thick; .140" diameter hole on end for mounting.	Fasten cable to housing.	1	42A38764
A-415		CLIP, CRYSTAL: same as C-403.	Holds spare crystals.		
A-16		COVER, TUNER ADJUSTMENT SCREW: aluminum, black wrinkle finish; $3\frac{3}{4}$ " long, $1\frac{1}{16}$ " wide, .032" thick; 1 hole .136" diameter, slot on end.	Compensator screw cover.	1	15A60929
A-417		COVER, TUNER PANEL: aluminum, black wrinkle finish; 6.374" wide, 7.624" long, 1.2964" high, .062" thick stock; drilled and punched for parts mounting.	Cover.	1	15C60935
A-418		HOUSING, TUNER: cast aluminum; overall dimensions: $10\frac{3}{16}$ " long, $6\frac{3}{8}$ " wide, 5.187" high.	Parts mounting.	1	62E60971
A-419		PLATE, BEARING RETAINER: $1\frac{3}{16}$ " square, .050" thick; four .120" diameter holes on each corner, one .781" diameter hole in center; cold rolled steel, white cadmium plated.	Front bearing retainer.	1	64A60747
A-420		PLATE, COVER (TOP): aluminum; $10\frac{3}{16}$ " long, $6\frac{3}{8}$ " wide, .062" thick; 7 holes .116" diameter; 1 hole for window $1\frac{1}{2}$ " diameter.	Top cover.	1	64C102433
A-421		PLATE, COVER (BOTTOM): aluminum, $10\frac{3}{16}$ " long, $6\frac{3}{8}$ " wide, .062" thick; 9 holes .116" diameter.	Bottom cover.	1	64C60853
A-422		PLATE, LOCKING: black fiber; $3\frac{1}{8}$ " long, $\frac{3}{8}$ " wide, $\frac{1}{16}$ " thick; 2 mounting holes .125" diameter, 9 holes equally spaced .113" diameter.	Cam track screw retainer.	1	64A102060
A-423		SLEEVE, RUBBER: neoprene; $\frac{5}{16}$ " outside diameter, $\frac{3}{16}$ " inside diameter, $\frac{3}{8}$ " long.	Cable clamp.	18	37K102409
A-424		SPACER: aluminum; $\frac{1}{4}$ " outside diameter, .120" diameter, $\frac{3}{16}$ " long.	Mount terminal strip and cam track.	44	46A60926
A-425		SPACER, CAM TRACK: aluminum; .250" long, $\frac{1}{4}$ " diameter; .125" diameter hole in center.	Mount cam track assembly.	46	46A60872
A-426		SUPPORT, VARIABLE CAM ADJUSTMENT SCREW: aluminum 3S, caustic etch; overall dimensions: $3\frac{1}{8}$ " long, $\frac{3}{8}$ " wide; 2 holes, one in each end, .125" diameter, 9 holes centered, 6-32 tap, class 2 fit.	Part of cam track assembly.	1	7A60873
A-427		SPACER, VARIABLE CAM TRACK: aluminum; $\frac{3}{16}$ " long, $\frac{1}{4}$ " outside diameter, .120" inside diameter.	Cam track spring spacer.	44	46A60926

TABLE OF REPLACEABLE PARTS

MAJOR UNIT: Tuning Unit TN-3/APR-1

MODEL: Radio Receiving Equipment AN/APR-1 and AN/SPR-1

Reference Symbol	Navy Stock No.	Name of Part and Description	Function	Mfr. and Desig. or AWS Type	Cont. or Gov't Dwg. or Spec. No.
A-428		WINDOW, DIAL: acetate; 3 <sup>3</sup> / <sub>16</sub> " long, 1 <sup>5</sup> / <sub>8</sub> " wide, .062" thick; 4 holes .108" diameter.	Dial window.	39	61A60889
A-429		WINDOW, TOP COVER: acetate; 2" square, .020" thick; 4 holes .104" diameter.	Top cover window.	1	61A102126
A-430		BRACKET, ANTENNA COIL MOUNTING: cold rolled steel, white nickel plated; L shaped; 1 hole .328" diameter, 2 holes .156" diameter.	Mount antenna coil L-407.	1	7A60884
A-431		ASSEMBLY: alignment tool: same as A-301.	I.F. coil alignment.		
C-401		WASHER, CAPACITOR: phosphor bronze, silver plated; 1 <sup>1</sup> / <sub>4</sub> " outside diameter, .144" diameter hole, .020" thick.	Meter by-pass for test purposes only.	1	4A60964
C-402		WASHER, CAPACITOR: same as C-401.	B+ by-pass capacitor.	1	42A60954
C-403		CLIP, CRYSTAL: phosphor bronze, silver plate; plate: 1 <sup>3</sup> / <sub>16</sub> " long, 1 <sup>1</sup> / <sub>2</sub> " wide, .020" thick; clip end: 1 <sup>3</sup> / <sub>32</sub> " long, 1 <sup>5</sup> / <sub>16</sub> " high, 3 <sup>1</sup> / <sub>16</sub> " wide; U shaped.	Coupling.	2 #1469	21B6633
C-404		CAPACITOR: fixed, mica; 15 micro-microfarads, ±5%, 300 volts d-c; color coded: brown, green, black, orange; 1 <sup>1</sup> / <sub>16</sub> " long, 7 <sup>1</sup> / <sub>16</sub> " wide, 1 <sup>1</sup> / <sub>64</sub> " thick; axial leads 1 <sup>1</sup> / <sub>4</sub> " long.	Part of antenna filter.	2 #1469	21B6628
C-405		CAPACITOR: fixed, mica; 10 micro-microfarads, ±5%, 300 volts d-c; color coded: brown, black, black, gold; 1 <sup>1</sup> / <sub>16</sub> " long, 7 <sup>1</sup> / <sub>16</sub> " wide, 1 <sup>1</sup> / <sub>64</sub> " thick; axial leads 1 <sup>1</sup> / <sub>4</sub> " long.	Part of antenna filter.	2 #1468X	21B6579
C-406		CAPACITOR: same as C-404.	Part of antenna filter.	1	4A60951
C-407	R16-C-10017-56	CAPACITOR: fixed, mica; 500 micro-microfarads, ±10%, 400 volts d-c; color coded: green, black, brown, silver; 1 <sup>1</sup> / <sub>16</sub> " long, 7 <sup>1</sup> / <sub>16</sub> " wide, 1 <sup>1</sup> / <sub>64</sub> " thick; axial leads 1 <sup>1</sup> / <sub>4</sub> " long.	Coupling.		
C-408		CAPACITOR: same as C-102.	I.F. by-pass.		
C-409	R16-GV-4A60951	WASHER, CAPACITOR: aluminum; 2 <sup>9</sup> / <sub>32</sub> " outside diameter, .252" inside diameter, .051" thick.	B+ by-pass.		
C-410		WASHER, CAPACITOR: same as C-409.	Filament by-pass.		
C-411		WASHER, CAPACITOR: same as C-409.	Hash filter.		
C-412		CAPACITOR: capacity between grid bar and oscillator butterfly.	Grid coupling.		
E-401	R16-GV-1B100730	ASSEMBLY, ANTENNA FILTER: composed of: mounting strip and bushing assembly E-402, screw H-461, lockwasher H-403, nut H-415, coil, coupling L-404, capacitor C-405, coil L-406, capacitor C-404, capacitor C-406, and coil L-403.	Suppress 200 megacycle carrier.	1	1B100730
E-402		ASSEMBLY, MOUNTING STRIP & BUSHING: phenolic, grade LE; 3 <sup>1</sup> / <sub>8</sub> " long, 7 <sup>7</sup> / <sub>8</sub> " wide, .125" thick, 2 holes .328" diameter, counterbored 5 <sup>7</sup> / <sub>8</sub> " diameter, 3 <sup>3</sup> / <sub>64</sub> " deep; 1 hole tapped 1 <sup>1</sup> / <sub>4</sub> -28 thread; 2 holes .125" diameter; 2 holes .152" diameter; bushing: stainless steel, .187" square, .250" high, 1 hole tapped 4-40 thread, stud end .146" diameter.	Tie point.	1	1X100759

MODEL: Radio Receiving Equipment AN/APR-1 and AN/SPR-1		TABLE OF REPLACEABLE PARTS			MAJOR UNIT: Tuning Unit TN-3/APR-1		
Reference Symbol	Navy Stock No.	Name of Part and Description	Function	Mfr. and Desig. or AWS Type	Cont. or Gov't Dwg. or Spec. No.		
E-403		BAR, GRID: brass, silver plated; Z shaped; overall dimensions: 1 <sup>25</sup> / <sub>32</sub> " long, 1/2" high, 1/4" thick; 2 holes .158" diameter, 1 hole tapped 2-56 thread, 1 hole tapped 6-32 thread.	Mount tube V-401.	1	46A60966		
E-404		BRACKET, TUBE: brass, silver plated; L shaped, T form; 1/8" thick stock; overall dimensions: 1" x 1 <sup>11</sup> / <sub>32</sub> " x 2 <sup>1</sup> / <sub>32</sub> " x 3/8" x 1 <sup>13</sup> / <sub>16</sub> " x 3/8".	Mount tube V-401.	1	7A100709		
E-405		BAR, PLATE: brass, silver plated; Z shaped; overall dimensions: 2 <sup>5</sup> / <sub>16</sub> " long, 5/8" high, 1/4" thick; 2 holes .106" diameter, 1 hole tapped 2-56 thread.	Mount tube V-401.	1	46A60826		
E-406		CABLE, ANTENNA: #18 solid bare copper wire; 3/64" wall, copolene insulation shielded with seamless copper tubing, silver plated; 6 1/2" long, bent to fit mounting location.	Antenna lead-in.	1	30A100766		
E-407	R16-GV-42A100731	CLIP, TUBE: phosphor bronze, silver plated; overall dimensions: 1 <sup>1</sup> / <sub>32</sub> " long, 7/32" high, 5/16" wide, .015" thick.	Mount tube V-401.	1	42A100731		
E-408	R16-GV-14A60871	DIELECTRIC, CRYSTAL: clear India ruby mica; overall dimensions: 2 <sup>9</sup> / <sub>32</sub> " long, 1 <sup>9</sup> / <sub>32</sub> " wide, .032" thick; 2 holes .193" diameter.	Dielectric for capacitor C-403.	37	14A60871		
E-409		INSULATOR, CAPACITOR: natural phenolic, grade XX; 1 <sup>5</sup> / <sub>64</sub> " long, .144" diameter hole; collar: 3/8" outside diameter, 1/16" thick; body: 1/64" long, .247" diameter.	Capacitor C401 and C-402, insulator.	34	14A60952		
E-410		INSULATOR, CAPACITOR PLATE: clear India ruby mica; 1 1/2" outside diameter, .144" diameter hole, .003" thick.	Capacitors C-401, and C-402, dielectric.	37	14A60949		
E-411	R16-GV-14A60689	INSULATOR, CRYSTAL CLIP: phenolic, grade XX; body: 9/32" diameter, 1/16" thick; collar: .190" diameter, .040" high; .101" diameter hole.	Insulator for mounting capacitor C-403.	1	14A60869		
E-412	R16-GV-14A60883	INSULATOR, FILTER CLIP: phenolic, grade XX; overall dimensions: 7/16" long, 1 <sup>1</sup> / <sub>32</sub> " wide, .062" thick; 1 hole .089 diameter.	Tube bracket insulator.	1	14A60883		
E-413	R16-GV-14A60868	INSULATOR, FILTER CLIP: phenolic, grade XX; body: 5/16" outside diameter, 1/16" thick; collar: .166" outside diameter, 3/64" high; .089" diameter hole.	Tube bracket insulator.	1	14A60868		
E-414	R16-GV-14A60947	INSULATOR, GRID BAR: phenolic, grade XX; body: 1/4" diameter, .125" thick; collar: .145" diameter, 1/32" high; hole .154" diameter x .028" deep to .103" diameter x .128" deep.	Grid bar insulator.	1	14A60947		
E-415	R16-GV-14A60968	INSULATOR, GRID BAR: phenolic, grade XX; body: .308" diameter, 1/16" thick; collar: .145" diameter, 1/32" high; .103" diameter hole.	Mount grid bar.	1	14A60968		
E-416	R16-GV-14A60969	INSULATOR, MICA: clear India ruby mica; 3 <sup>1</sup> / <sub>32</sub> " square, .003" thick; .250" diameter hole.	Capacitors C-409, C-410 and C-411 dielectric.	37	14A60969		
E-417	R16-GV-14A60968	INSULATOR, RECEPTACLE: phenolic, grade XX; body: 1/2" diameter, 1/16" thick; collar: .370" diameter, 3/32" thick; .251" diameter hole.	Capacitors C-409, C-410, and C411, insulator.	34	14A60948		
E-418		INSULATOR, RECEPTACLE: polystyrene; .555" outside diameter, .144" inside diameter, .125" thick.	Banana plug insulator.	1	14A48736		

TABLE OF REPLACEABLE PARTS  
MODEL: Radio Receiving Equipment AN/APR-1 and AN/SPR-1

MAJOR UNIT: Tuning Unit TN-3/APR-1

Reference Symbol	Navy Stock No.	Name of Part and Description	Function	Mfr. and Desig. or AWS Type	Cont. or Gov't Dwg. or Spec. No.
E-419	R16-GV-14A100771	INSULATOR, STAND OFF: ceramic; 1/2" outside diameter, 5/16" high, countersunk 5/16" diameter, 3/16" deep, .140" diameter hole.	Antenna lead tie point.	1	14A100771
E-420		LUG, SOLDERING: same as E-103.	Terminal point.		
E-421		LUG, SOLDERING: steel, hot tinned plated; #10 mounting hole, .093" diameter wire hole, .195" thick; plain flat.	Tie point.	22 #2681	29K5301
E-422	R17-T-3760	LUG, SOLDERING: Cinch solder plated; .020" thick, brass; one .093" diameter wire hole; 1/4" mounting hole; plain flat type.	Tie point.	9 #1467-A	29K5234
E-423		LUG, SOLDERING: hot tin dipped; .018" thick, phosphor bronze; one .093" wire hole; 6L mounting hole; lock-flat type.	Tie point.	22 #2101	29K5249
E-424		LUG, SOLDERING: .018" thick, phosphor bronze, hot tinned plated; lock-bent; two .075" diameter wire holes, one #4 mounting hole.	Tie point.	22 #2104	29K5293
E-425		LUG, SOLDERING: brass, hot tin dipped; plain flat; #4 mounting hole, 0.08" diameter wire hole, .018" thick.	Tie point.	22 #2522	29K5222
E-426		PLUG, BANANA: phosphor bronze, silver plated, 4 leaves; overall dimensions: 1 3/16" long, 5/16" diameter, hexagonal collar.	Plug P401 and P402 contact.	1	29A48302
E-427		SHIELD, ANTENNA TUNER: copper, white silver plated; Z shaped; overall dimensions: 1 1/2" high, 1 1/2" long, .025" thick; ends flanged for mounting with 3 holes. 1.56" diameter.	Antenna shield.	1	26C48608
E-428		SPACER, TUBE BRACKET: phenolic, grade LE; 13/16" long, 5/8" wide, 3/8" thick; 2 holes tapped 8-32 thread.	Mount tube bracket.	1	46A60874
E-429		STRIP, TERMINAL: same as A-113.	Tie point for choke L-402.		
E-430		STRIP, TERMINAL: phenolic, grade XX; 1 1/8" long, 3/8" wide, 1/16" thick; 1 Cinch lug #1436, 2 Cinch lugs #2423.	Tie point.	9	31A60875
E-431		WASHER, CAPACITOR: cold rolled steel, silver plated; 1/2" outside diameter, .144" hole, .032" thick.	Fastener capacitors C-401 and C-402.	1	4A60962
E-432		STRIP, TERMINAL: phenolic, grade XXP; 1 1/2" long, 3/8" wide, 1/16" thick; 2 Cinch lugs #1436, 2 Cinch lugs #2423.	Tie point.	9	31A60837
E-433	R16-GV-14A100768	INSULATOR, FEED THRU: crolite; .500" outside diameter, 3/16" thick; collar: .370" diameter, .045" high; .147" diameter hole.	Antenna lead tie point.	1	14A100768
E-434		ASSEMBLY, ANTENNA BUTTERFLY AND CLIP: composed of antenna butterfly assembly LC-402, crystal dielectric E-408, crystal clip C-403, crystal clip insulator E-411, and I-F resistor assembly R-404.	Antenna tank circuit.		51X102464
E-435		ASSEMBLY, OSCILLATOR BUTTERFLY AND CLIP: composed of: oscillator, butterfly and bars assembly LC-401, grid bar insulator E-414, grid bar E-403, filter clip insulator, E-413, plate bar, E-405 and tube clip E-407.	Oscillator tank circuit.		51X102425

MODEL: Radio Receiving Equipment AN/APR-1 and AN/SPR-1		TABLE OF REPLACEABLE PARTS			MAJOR UNIT: Tuning Unit TN-3/APR-1		
Reference Symbol	Navy Stock No.	Name of Part and Description	Function	Mfr. and Desig. or AWS Type	Cont. or Gov't Dwg. or Spec. No.		
E-436		CLIP, CRYSTAL MOUNTING: Phosphor Bronze silver plated; .718" large x .843" wide x .468 high overall; Galvin Special; (.250" maximum jaw opening).	Mount spare crystal.		42A60458		
H-401		GROMMET: rubber, black; 7/16" outside diameter, 3/8" thick, 3/32" groove along edge; 5/32" diameter hole.	Feed through.	6 #374	37A30246		
H-402		HANDLE: aluminum, black finish; overall dimensions: 47/8" long, 315/16" high, 1/2" wide; 4.250" between mounting centers; mounting studs 5/16" diameter tapped 8-32 thread.	Tuner handle.	1	55B60264		
H-403		LOCKWASHER: #4 internal, 17/64" outside diameter, .016" thick; spring steel, white nickel finish.	Fasten terminal strip.	22 #1204	4S9732		
H-404		LOCKWASHER: #6 external, 5/16" outside diameter, .018" thick; spring steel, white nickel plated.	General.	22	4S8449		
H-405		LOCKWASHER: #4 internal; spring steel, white cadmium plated.	Mount housing bushings.	22	4S9741		
H-406		LOCKWASHER: #3 internal, spring steel, white nickel plated.	General.	22 #1203	4S8446		
H-407		LOCKWASHER: #2 internal spring steel, white nickel plated.	Fasten tube clip.	22	4S8447		
H-408		LOCKWASHER: #8 external spring steel, white nickel plated.	Mount butterflies and hold down bracket.	22	4S8448		
H-409		LOCKWASHER: #6 internal, 9/32" outside diameter, .018" thick, spring steel, white nickel plated.	Fasten lug on grid bar; backing plate on panel.	22	4S9725		
H-410		LOCKWASHER: #4 internal, 9/32" outside diameter, .016" thick; spring steel, white nickel finish.	General.	22 #1104	4S9726		
H-411		LOCKWASHER: #6 internal, 5/16" outside diameter, .018" thick; spring steel, black nickel finish.	Cover assembly.	22 #1106	4S9728		
H-412		LOCKWASHER: #8 internal, 21/64" outside diameter, .020" thick, spring steel, white nickel plated.	Fasten tube bracket.	22 #1208	4S9730		
H-413		NUT: same as H-208.	Fasten hold down bracket.				
H-414		NUT: same as H-102.	General.				
H-415		NUT: same as H-317.	Fasten terminal strip.				
H-416		NUT: 4-40 thread, 1/4" diameter, 3/32" thick, hexagonal; steel, white nickel plated.	Mount cam rollers.	26	2S9609		
H-417		NUT: 2-56 thread, 3/16" diameter, 1/16" thick, hexagonal; brass, white nickel plated.	Fasten tube clip.	26	2S8372		
H-418		NUT: same as H-319.	Mount chassis plug bushing.				



TABLE OF REPLACEABLE PARTS

MODEL: Radio Receiving Equipment AN/APR-1 and AN/SPR-1

MAJOR UNIT: Tuning Unit TN-3/APR-1

Reference Symbol	Navy Stock No.	Name of Part and Description	Function	Mfr. and Desig. or AWS Type	Cont. or Gov't Dwg. or Spec. No.
H-419		NUT: 4-40 thread, 3/16" diameter, hexagonal; brass, white nickel plated.	Cover assembly.	26	2S8376
H-420	R16-GV-2S9620	NUT: 1/4-28 thread, 3/8" diameter, 9/64" thick; hexagonal; brass, white nickel finish.	Mount receptacles X-401, X-402, and X-403.	36	2S9620
H-421		NUT: DRIVE SHAFT: brass, nickel plated; 3/4-20 thread, 7/8" outside diameter, hexagonal, 5/32" thick.	Mount housing bushing.	1	2K101970
H-422		NUT: 3-48 thread, 3/16" diameter, 1/16" thick; hexagonal, brass, white nickel plated.	Fasten capacitor C-403 and grid bar.	26	2S8373
H-423		NUT, CAP: brass, silver plated; 1/4-28 thread, 5/32" long, 3/8" diameter hexagonal collar; .147" diameter hole.	Antenna feed thru.	1	2A60927
H-424		PIN, PANEL ALIGNMENT: stainless steel, passivated; 7/16" long, .125" diameter.	Front panel alignment.	1	47A100726
H-425		RIVET: .088" diameter, 5/32" long; cold rolled steel, polished nickel finish.	Fasten window.	24 S1727-2 1/2	5S7770
H-426		RIVET: .088" diameter, 3/16" long, cold rolled steel, black nickel plated.	Fasten window dial.	24 #1727-3	5S7786
H-427		RIVET: .122" diameter, 3/16" long, cold rolled steel, black nickel finish.	Fasten dial lock assembly.	24 #1793	5S6833
H-428		RIVET, CAM ROLLER LINK: stainless steel; .166" diameter, .248" long; .093" long x .124" diameter flaring end; head 5/16" diameter, .062" thick.	Fasten helical gear to link.	1	5A60736
H-429		RIVET, SHOULDER: stainless steel; body: .109" long, .093" diameter; shoulder .059" long, .130" diameter, head: 5/16" diameter, .074" thick.	Fasten compensator screw cover.	1	5A60956
H-430		SCREW: 6-32 thread, 1/4" long, slotted round head; brass, white nickel plated.	General.	26	3S1211
H-431		SCREW: 6-32 thread, 3/4" long, slotted round head; brass, polished nickel finish.	Fasten insulator standoff.	26	3S1215
H-432		SCREW: 6-32 thread, 7/16" long, slotted round head; brass, white nickel plated.	Mount front panel.	26	3S1226
H-433		SCREW: 3-48 thread, 3/16" long, slotted flat head; brass, white nickel plated.	Fasten tuner dial.	26	3S1230
H-434		SCREW: 2-56 thread, 5/16" long, slotted flat head; brass, white nickel plated.	Fasten dial indicator.	26	3S1231
H-435		SCREW: 4-40 thread, 3/8" long, slotted flat head; brass, white nickel plated.	Fasten lug to housing.	26	3S1232
H-436		SCREW: 4-40 thread, 1/4" long, slotted flat head, brass, white nickel finish.	Fasten top and bottom covers.	26	3S1233
H-437		SCREW: same as H-104.	General.		

MODEL: Radio Receiving Equipment AN/APR-1 and AN/SPR-1		TABLE OF REPLACEABLE PARTS			MAJOR UNIT: Tuning Unit TN-3/APR-1		
Reference Symbol	Navy Stock No.	Name of Part and Description	Function	Mfr. and Desig. or AWS Type	Cont. or Gov't Dwg. or Spec. No.		
H-438		SCREW: 8-32 thread, 3/8" long, slotted round head; brass, white nickel plated.	Fasten tube bracket.	26	3S1235		
H-439		SCREW: 8-32 thread, 3/8" long, slotted flat head; brass, white nickel plated.	Fasten lug for choke L-401.	26	3S1241		
H-440		SCREW: 2-56 thread, 1/8" long, slotted round head, brass, white nickel plated.	Fasten tube clip.	26	3S1243		
H-441		SCREW: 2-56 thread, 5/16" long, slotted round head; brass, white nickel plated.	Fasten tube clip.	26	3S1244		
H-442		SCREW: same as H-211.	Mount spare crystal clips.				
H-443		SCREW: same as H-216.	Gear retainer.				
H-444		SCREW: 8-32 thread, 5/8" long, slotted flat head, steel, white nickel finish.	Fasten handle and cover to housing.	26	3S1257		
H-445		SCREW: 8-32 thread, 7/16" long, slotted fillister head; brass, white nickel finish.	Fasten helical gear.	26	3S1258		
H-446		SCREW: 8-32 thread, 5/8" long, slotted fillister head; brass, white nickel plated.	Fasten antenna lever on antenna rotor arm.	26	3S1259		
H-447		SCREW: 8-32 thread, 7/16" long, slotted round head; steel, white nickel plated.	Mount butterflies.	26	3S1261		
H-448		SCREW: 4-40 thread; 5/16" long; slotted flat head; steel, white nickel finish.	Mount bearing adjustment bracket.	26	3S1262		
H-449		SCREW: 4-40 thread; 3/8" long; slotted flat head; steel, white nickel finish.	Mount bearing retainer plate.	26	3S1263		
H-450		SCREW: 6-32 thread, 1 3/8" long, slotted round head; brass, white nickel plated.	Fasten backing plate.	26	3S1275		
H-451		SCREW: 6-32 thread, 1/2" long, slotted binderhead; brass, black nickel finish.	Cover assembly.	26	3S1277		
H-452		SCREW: 4-40 thread, 1/2" long, slotted flat head; brass, white nickel plated.	Mount filter assembly.	26	3S1282		
H-453		SETScrew: 8-32 thread; 3/16" long; cup point; Allen head; case hardened steel, white cadmium finish.	General.	40	3S7110		
H-455		SCREW: 6-32 thread, 9/16" long, slotted round head; brass, white nickel plated.	Mount capacitors C-401 and C-402.	26	3S1855		
H-456		SCREW: 4-40 thread, 3/4" long, slotted round head, brass, white nickel plated.	Mount cam track assembly.	26	3S1856		
H-457		SCREW: 4-40 thread, 1" long, slotted round head; brass, white nickel plated.	Mount cam track assembly.	26	3S1857		

TABLE OF REPLACEABLE PARTS  
MODEL: Radio Receiving Equipment AN/APR-1 and AN/SPR-1

MODEL: Radio Receiving Equipment AN/APR-1 and AN/SPR-1		MAJOR UNIT: Tuning Unit TN-3/APR-1			
Reference Symbol	Navy Stock No.	Name of Part and Description	Function	Mfr. and Desig. or AWS Type	Cont. or Gov't Dwg. or Spec. No.
H-458		SCREW: 6-32 thread, 1 1/2" long, slotted round head; brass, white nickel plated.	Fasten resistor R405.	26	3S1858
H-459		SCREW: 4-40 thread, 1/4" long, slotted round head; brass, white nickel plated.	Cover assembly.	26	3S8069
H-460		SCREW: 8-32 thread, 5/16" long, slotted binder head; steel, black, nickel finish.	Fasten hold-down bracket.	26	3S8076
H-461		SCREW: 4-40 thread, 5/16" long, slotted round head; steel, white nickel finish.	Mount lugs on terminal strip.	26	3S8081
H-462		SCREW: 4-40 thread, 1/4" long, slotted binderhead; brass, black nickel plated.	Fasten compensator cover.	26	3S9679
H-463		SETScrew: 6-32 thread, 3/16" long, Allen head, case hardened steel, white cadmium plated.	Fasten idler pinion gear.	40	3S9700
H-464		SETScrew: 8-32 thread, 1" long, Allen head; case hardened steel, white cadmium plated.	Fasten tuner knob.	40	3S9705
H-465		SCREW: VARIABLE CAM ADJUSTMENT: stainless steel; 6-32 thread, 1 1/2" long, slotted binderhead.	Cam track compensator.	1	3K60833
H-466		STUD, RIVET: stainless steel; 1 end threaded 1/4-20; 3/16" long, other end tapped 6-32 thread, .247" outside diameter, .476" long; center 1/2" diameter hexagonal, .568" long.	Mount capacitor operating cam.	1	46A60743
H-467		STUD, ROTOR LINK: stainless steel; stud head; 3/8" diameter, .064" body; .249" diameter, .106" long; flaring end: .124" diameter, .110" long.	Fasten cam link to lever and cam.	1	46A60751
H-468		STUD, SPINNER KNOB: stainless steel; body: .515" long, .203" diameter; head: .281" diameter, 3/64" thick; stud end: .296" long, .122" diameter.	Fasten knob handle.	1	46A61315
H-469		WASHER: phenolic, grade XXP; 11/32" outside diameter, .144" inside diameter, .093" thick.	Fasten resistor R-405.	1	4A8783
H-470		WASHER: 1/8" inside diameter, 3/8" outside diameter, .032" thick, cold rolled steel, white nickel plated.	Roller washer.	35	4S8270
H-471		WASHER: 7/16" outside diameter; 5/32" inside diameter; .0490" thick; cold rolled steel; white cadmium finish.	Capacitor C-402 mounting.	35	4S7566
H-472		WASHER: 3/8" outside diameter, 5/32" inside diameter, .032" thick; cold rolled steel; white cadmium plated.	Fasten resistor R-405.	35	4S7566
H-473		WASHER: .088" inside diameter, 3/16" outside diameter, .014" thick; brass, white nickel plated.	Fasten windows.	41	4S8277
H-474		WASHER: 1/2" outside diameter, .140" inside diameter, .032" thick; brass, white nickel finish.	Gear retainer.	26	4S8271

TABLE OF REPLACEABLE PARTS  
MODEL: Radio Receiving Equipment AN/APR-1 and AN/SPR-1

MAJOR UNIT: Tuning Unit TN-3 / APR-1

Reference Symbol	Navy Stock No.	Name of Part and Description	Function	Mfr. and Desig. or AWS Type	Cont. or Gov't Drawg. or Spec. No.
H-475		WASHER: 3/16" outside diameter, .103" inside diameter, .0201" thick; brass, white nickel finish.	Fasten capacitor C-403 and grid bar.	41	4S8269
H-476		WASHER, HANDLE: brass, white nickel plated; 9/16" outside diameter, .439" inside diameter, .032" thick.	Fasten handle.	1	4A101095
H-477		WASHER, OSCILLATOR COIL: fibre; 9/32" outside diameter, .125" inside diameter, .020" thick.	Fasten insulator.	1	4A41669
H-478		WASHER, SPRING: phosphor bronze, white nickel plated; 3/4" outside diameter, .314" inside diameter; .016" thick; bent for spring tension 1/16" from horizontal.	Tuning knob stop release.	1	4A100777
H-479		WASHER, SPRING: phosphor bronze, white nickel plated; 5/16" outside diameter, .140" inside diameter, .010" thick; arc shaped.	Fasten handle.	1	4A101093
H-480		WASHER, DIAL SHAFT: stainless steel; 3/4" outside diameter, .375" inside diameter, .062" thick.	Dial shaft washer.	1	4A60261
H-481		STUD, COVER: cold rolled steel, cadmium plated; overall dimensions: 1 1/16" long, 5/16" hexagonal; one end tapped 6-32 thread; other end 6-32 threaded stud.	Mounting panel cover.	1	46A60246
H-482		LOCKWASHER: same as H-604.			
H-483		WRENCH, ALLEN: same as H-345.	For 6-32 Screws.		
H-484		WRENCH, ALLEN: same as H-346.	For 8-32 Screws.		
L-401	R16-GV-24A102357	COIL, R.F. CHOKE: 32-42 micro-microfarads at 30 megacycles; 40 turns of #29 plain enameled copper wire, 3/4" long, 7/32" diameter dummy form.	Filament choke.	1	24A102357
L-402		COIL, R.F. CHOKE: same as L-401.	Filament Choke.		
L-403		COIL, TN-3 FILTER: 1 1/4 turns (critical) #22 solid tinned copper wire; variable slug tuned; 5/16" diameter core; overall dimensions: 1 5/32" long, 13/16" diameter; includes mounting nut.	Part of antenna filter.	1	24A104858
L-404		COIL, COUPLING: 5 1/2 turns of #22 solid tinned copper wire, 5/16" diameter, 3/4" core; 145-150 micro-microfarads at 30 megacycles.	Antenna filter coupling.	1	24A100728
L-405		COIL, TN-3 FILTER: 1 turn (critical) #22 solid tinned copper wire; variable slug tuned; 5/16" diameter core; overall dimensions: 1 5/32" long; 13/16" diameter; includes mounting nut.	Part of antenna filter.	1	24A100729
L-406		COIL, COUPLING: #16 gauge tinned copper wire; 2 loops center tapped; 3/8" inside diameter loops.	Part of antenna filter.	1	24A100735
L-407	R16-GV-24A102353	COIL, I.F.: 6 1/2 turns of #30 enameled covered copper wire on 5/16" core, variable slug tuned; overall dimensions: 1 1/8" long, 1 3/16" diameter.	I-F coil.	1	24A102353

TABLE OF REPLACEABLE PARTS  
MODEL: Radio Receiving Equipment AN/APR-1 and AN/SPR-1

TABLE OF REPLACEABLE PARTS		MAJOR UNIT: Tuning Unit TN-3/APR-1			
Reference Symbol	Navy Stock No.	Name of Part and Description	Function	Mfr. and Desig. or AWS Type	Cont. or Gov't Dwg. or Spec. No.
LC-401		ASSEMBLY, OSCILLATOR, BUTTERFLY AND BARS: variable; 7 rotor plates, 8 stator plates; overall dimensions: $4\frac{3}{8}$ " diameter, 4" high.	Oscillator tank circuit.	1	51C48606
LC-402		ASSEMBLY, ANTENNA BUTTERFLY: variable; 4 rotor plates, 5 stator plates; overall dimensions: $2\frac{1}{2}$ " diameter, $3\frac{7}{16}$ " long.	Antenna tank circuit.	1	51C8604
N-401		DIAL, TUNER: aluminum, black finish, white numerals and markings; $4\frac{1}{4}$ " diameter, $\frac{1}{16}$ " thick; $\frac{5}{16}$ " diameter center hole; three .093" holes at center for mounting.	Dial scale reading in megacycles.	1	34C100705
O-401		ASSEMBLY, BACKING PLATE AND DIAL INDICATOR: composed of plate, backing O-438; spacer, indicator O-446; indicator, dial O-457; and screw H-434.	Dial scale reading assembly.	1	1X100761
O-402	R16-GV-1X48704	ASSEMBLY, CAM LINK AND LEVER: composed of: cam, capacitor operator O-413; link, antenna rotor cam O-428; lever, antenna rotor O-427, stud, rotor link H-467; and screw H-446.	Vary antenna oscillator.	1	1X48704
O-403		ASSEMBLY, HELICAL GEAR AND LINK: composed of: gear, helical O-423; link, cam roller O-429; and rivet, cam roller link H-428.	Oscillator butterfly.	1	1X103964
O-404		ASSEMBLY, SHAFT AND WORM: shaft: stainless steel, $6\frac{9}{16}$ " long, .375" diameter at center, .310" diameter at ends, tapered and undercut; worm: stainless steel, .625" pitch diameter, .748" outside diameter, $1\frac{5}{16}$ " long overall; pin: stainless steel, tapered; $\frac{9}{16}$ " long, .125" diameter to .114" diameter.	Drive shaft.	1	51X48702
O-405	R16-GV-1X100763	ASSEMBLY, SPINNER KNOB: composed of: knob, spinner O-426; disc, spinner, knob O-418; handle, knob O-424; and stud, spinner knob H-468.	Tuner knob assembly.	1	1X100763
O-406		ASSEMBLY, SPINNER LOCK: composed of: spring steel spring, pin, 8-32 thread thumbscrew, clamp, and plate; overall dimensions: $1\frac{1}{8}$ " x $1\frac{1}{8}$ " x $\frac{3}{4}$ ".	Handle shaft lock.	1	1X41844
O-407		BALL BEARING: .8661" diameter, .2756" high, .3150" diameter hole.	Drave shaft bearing.	38 #SP-38	43A102408
O-408		BEARING, OILITE: brass, .440" outside diameter, .311" inside diameter, .375" long.	Gear bearing.	31	43A60258
O-409		BEARING, OILITE: brass; .440" outside diameter, .311" inside diameter, .687" long.	Gear mounting.	31	43K60259
O-410		BEARING, OPERATING CAM: .468" long, .377" outside diameter, .2505" inside diameter.	Capacitor operating cam bearing.	31 #A-304-31	43A60744
O-411		BUSHING, OPERATING CAM: stainless steel, overall dimensions: $1\frac{1}{16}$ " outside diameter, .478" long, .375" inside diameter.	Mount operating cam.	1	43A60745
O-412		BUSHING, THREADED ADJUSTMENT: stainless steel; $\frac{7}{6}$ -40 thread, .625" inside diameter, .375" thick, 4 slots on upper edge, $\frac{1}{16}$ " wide.	Bearing retainer.	1	43A60748

TABLE OF REPLACEABLE PARTS  
MODEL: Radio Receiving Equipment AN/APR-1 and AN/SPR-1

MAJOR UNIT: Tuning Unit TN-3/APR-1

Reference Symbol	Navy Stock No.	Name of Part and Description	Function	Mfr. and Desig. or AWS Type	Cont. or Gov't Drawg. or Spec. No.
O-413		CAM, CAPACITOR OPERATOR: stainless steel, tapered; overall dimensions: 5 $\frac{3}{8}$ " long, 2 $\frac{11}{32}$ " wide, .064" thick; mounting hole .500" diameter.	Vary antenna oscillator.	1	45C60839
O-414		COLLAR, BEARING ADJUSTMENT SLEEVE: cold rolled steel, white cadmium plated; 1 $\frac{5}{32}$ " long, $\frac{7}{16}$ " outside diameter, .316" inside diameter.	Spacer for dog washer stop plate.	1	43A60746
O-415		COLLAR, DRIVE SHAFT: aluminum, 1 $\frac{1}{16}$ " outside diameter, .312" inside diameter, $\frac{1}{4}$ " thick; 2 holes tapped 8-32 thread.	Shaft retainer and spring tension adjustment.	44	43A60243
O-416		COLLAR, STOP: aluminum, $\frac{3}{4}$ " outside diameter, .316" inside diameter, $\frac{1}{4}$ " thick; 2 holes threaded 8-32; 1 slot $\frac{1}{16}$ " wide.	Dog washer retainer and stop.	43	43A60733
O-418		DISC, SPINNER KNOB: brass, black nickel plated; 2 $\frac{3}{8}$ " outside diameter, .031" thick; center hole .755" diameter, 4 keyways, .089" wide.	Locking disc.	1	49A61317
O-419		GEAR, BACKLASH: aluminum, .032" thick; 96 teeth; 2 slots for anti-backlash spring; 2.0416" outside diameter; .500" diameter hole in center.	Part of tuning gear assembly.	1	44B60240
O-420		GEAR, BACKLASH: aluminum; 3.0416" outside diameter, .032" thick; 144 teeth; .623" hole for mounting; 2 slots for anti-backlash springs.	Tuning gear on dial shaft.	1	44B60239
O-421		GEAR, BACKLASH: aluminum; 3.0416" outside diameter, .032" thick; 144 teeth; .500" diameter hole for mounting with four notches equally spaced; 2 slots for anti-backlash springs.	Tuning gear on dial shaft.	1	44B60242
O-422		GEAR, BACKLASH: aluminum, .032" thick; 96 teeth; 2 slots for anti-backlash spring; 2.0416" outside diameter; .623" diameter hole in center.	Part of tuning gear assembly.	1	44B60241
O-423		GEAR, HELICAL: cast bronze, white nickel plated; 6 complete teeth; overall dimensions: 2 $\frac{7}{16}$ " long, 1 $\frac{1}{16}$ " wide, .255" thick; center hole .403" diameter, end hole .169" diameter.	Vary oscillator butterfly.	1	44C60764
O-424		HANDLE, KNOB: phenolic, black; overall dimensions: 9 $\frac{1}{16}$ " long; $\frac{7}{16}$ " diameter; .211" diameter mounting hole.	Knob handle.	1	36A61319
O-425		HUB, DIAL: stainless steel; outside diameter $\frac{3}{4}$ ", .336" thick; 3 holes tapped 3-48 thread.	Mount dial shaft assembly.	1	43A60256
O-426		KNOB, SPINNER: aluminum, black finish; fluted; overall dimensions: 2 $\frac{3}{8}$ " diameter, 1" high; .313" mounting hole; .127" diameter spinner knob hole on top edge.	Tuner knob.	1	36B61323
O-427		LEVER, ANTENNA ROTOR: aluminum; overall dimensions: 2" long, 5 $\frac{5}{16}$ " high, $\frac{5}{16}$ " thick; 1 hole tapped 8-32 thread, 1 hole .405" diameter, 1 hole .128" diameter.	Mounts on antenna rotor stud.	1	45A60763
O-428		LINK, ANTENNA ROTOR CAM: aluminum; 6" long, .437" wide, .091" thick; .437" diameter hole at each end.	Connect antenna lever to capacitor cam.	1	45A60758
O-429		LINK, CAM ROLLER: aluminum; U shaped; overall dimensions: 1 $\frac{1}{2}$ " long, $\frac{5}{16}$ " wide, 1 $\frac{3}{32}$ " high.	Part of oscillator butterfly gear assembly.	1	45A60729

**TABLE OF REPLACEABLE PARTS**  
**MODEL: Radio Receiving Equipment AN/APR-1 and AN/SPR-1**      **MAJOR UNIT: Tuning Unit TN-3/APR-1**

Reference Symbol	Navy Stock No.	Name of Part and Description	Function	Mfr. and Desig. or AWS Type	Cont. or Gov't Dwg. or Spec. No.
O-430		PLATE, LOCKWASHER STOP: triangular shaped; 1 1/2" long, .853" high; .3145" hole in center; bent tit, .115" wide, .057" long; cold rolled steel, .062" thick, white cadmium finish.	Dog washer stop.	1	64A60749
O-431		PINION, GEAR: stainless steel; .7916" outside diameter, 3/16" thick; 36 teeth; .311" diameter hole.	Part of tuning gear assembly.	1	44B60244
O-432		PINION, IDLER: stainless steel; overall dimensions: .7916" outside diameter, 5/16" thick, .436" diameter hole; 36 teeth on gear portion.	Part of tuning gear assembly.	1	44B60262
O-433		PINION, IDLER (DRIVE GEAR): stainless steel; overall dimensions: .7916" diameter, .538" thick, .312" diameter hole; 2 holes tapped 6-32 thread for setscrews; 36 teeth on gear portion.	Tuning gear assembly.	1	44B60250
O-434		PINION, IDLER (TUNER DRIVE): stainless steel; overall dimensions: 1.0417" diameter, 17/32" thick; .468" diameter hole; 48 teeth on gear portion.	Part of tuning gear assembly.	1	44B60260
O-435		POINTER, ADJUSTMENT: aluminum; L shaped; 1 leg 1 5/8" long, 1 leg 1" long, .040" thick, center hole, .188" diameter, spring hole .052" diameter.	Cam screw adjustment pointer.	1	52K60735
O-436		ROLLER, CAM: stainless steel; 13/16" diameter, .222" thick; .079" wide groove along edge.	Antenna cam roller.	1	49A60732
O-437		ROLLER, VARIABLE CAM: stainless steel; 1" diameter, .177" thick, .190" diameter hole.	Cam track roller.	1	49A60737
O-438		PLATE, BACKING: aluminum; 3 1/2" long, 1 5/16" wide, .064" thick; 2 holes .156" diameter, 2 holes tapped 2-56 thread.	Mount dial indicator.	1	64A60252
O-439		SHAFT, CAM ROLLER: stainless steel; ends threaded 4-40; center disc .375" diameter, .032" thick; shaft .187" diameter; overall length 7/16".	Mount roller cams and pointer.	1	47A60762
O-440		SHAFT, DIAL: stainless steel; overall dimensions: 1 1/2" long, 1 end 5/8" diameter, center .435" diameter, other end .373" diameter.	Mounts dial.	1	47A60263
O-441		SHAFT, HAND WHEEL: stainless steel; overall dimensions: 2 3/8" long, 9/16" diameter at one end; .3905" diameter at tip.	Mount tuning knob part of tuning gear assembly.	1	47A60249
O-442		SLUG, SETSCREW: 1/16" wide, 7/64" diameter, .062" thick, aluminum.	Protect threads on adjustment bushing.	1	46A102197
O-443		SPACER, BACKING PLATE: aluminum; .906" long, 1/4" outside diameter, .144" inside diameter.	Backing plate spacer.	32	46A60238
O-444		SPACER, BEARING AND DRIVE SHAFT: .390" outside diameter, .317" .320" inside diameter, .162" thick; brass, white nickel finish.	Bearing spacer.	1	46A101552
O-445		SPACER, BEARING AND DRIVE SHAFT: brass, white nickel finish; 7/8" outside diameter, .756" inside diameter, .093" thick.	Bearing spacer.	1	46K101554

TABLE OF REPLACEABLE PARTS  
MODEL: Radio Receiving Equipment AN/APR-1 and AN/SPR-1

MAJOR UNIT: Tuning Unit TN-3/APR-1

Reference Symbol	Navy Stock No.	Name of Part and Description	Function	Mfr. and Desig. or AWS Type	Cont. or Gov't Dwg. or Spec. No.
O-446		SPACER, INDICATOR: aluminum; 5/32" outside diameter, .089" inside diameter, 9/64" long.	Indicator spacer.	44	46A60251
O-447		SPRING, ANTI-BACKLASH: phosphor bronze, white nickel plated; forms 45° angle with vertical and horizontal; 1 leg 3/4" long, 1 leg 11/16" long, .012" thick.	Helical gear anti-backlash spring.	1	41A102124
O-448		SPRING, CAM ROLLER TRACK: phosphor bronze, nickel plated; 2 3/4" long, 7/32" wide, .004" thick; 1 hole at end .113" diameter.	Cam track roller spring.	1	41A100722
O-449		SPRING, CAM TRACK: phosphor bronze, nickel plated; 2 5/8" long, 7/32" wide, .004" thick, hole on one end .113" diameter.	Cam track roller spring.	1	41A60943
O-450		SPRING, COMPRESSION COIL: stainless steel 7 1/2 turns, .016" diameter; 1/8" outside diameter, 1/2" long; closed ends.	Anti-backlash gear springs.	1	41A100992
O-451		SPRING, COMPRESSION COIL: stainless steel wire; 7 1/2 turns, .014" diameter; 1/8" outside diameter, 1/2" long; closed ends.	Anti-backlash gear spring.	1	4K100993
O-452		SPRING, OPERATING CAM: stainless steel wire, 51 turns of .035" diameter wire, 9/32" inside diameter, 9/32" loop at each end.	Operating cam spring.	1	41K60741
O-453		SPRING, POINTER ADJUSTMENT: stainless steel wire, .015" diameter; 54 turns, .116" inside diameter; 1/8" loop at each end.	Pointer spring.	1	41A60738
O-454		SPRING, RETAINER (FLAT): beryllium copper or phosphor bronze, silver plated; .040" diameter wire forming 5/8" outside diameter.	Banana plug insulator retainer.	1	41A48739
O-455		SPRING, RETAINER (BENT): beryllium copper or phosphor bronze, silver plated .040" diameter wire forming 5/8" outside diameter loop, 1/4" opening.	Insulator banana plug retainer.	1	41A48734
O-456		WASHER, DOG: cold rolled steel, white cadmium plated; 9/16" outside diameter, .315" inside diameter, .0625" thick; bent tit: .115" wide, 3/16" long.	Drive shaft stop.	1	4A14106
O-457		DIAL, INDICATOR: plexi-glass or lucite; triangular shaped; 3/4" high, 9/16" wide; 2 holes: .089" diameter, indicator line white filled.	Indicator dial.	1	52A60248
O-458		ASSEMBLY, PINION AND GEARS: composed of: backlash gear O-419, backlash gear O-422, idler pinion (drive gear) O-433, and compression coil spring O-431.	Part of gear assembly.	1	51X100760
P-401	R16-GV-28A60822	PLUG, CHASSIS: brass, silver plated; 3/4-20 thread, 7/8" mounting bushing; banana plug mounted in polystyrene insulator; overall dimensions: 1" diameter; 1 1/4" long.	Antenna.	1	28A60822
P-402		PLUG, CHASSIS: same as P-401.	I-F plug.		
R-401		RESISTOR: fixed, carbon; 4,700 ohms, ±10%, 1 watt, insulated; 3/4" long, .281" diameter; axial leads 1 1/2" long.	Parasitic suppressor.	22 518 Ins. 23 MB-1 Ins.	6B5576



**MODEL: Radio Receiving Equipment AN/APR-1 and AN/SPR-1**      **TABLE OF REPLACEABLE PARTS**      **MAJOR UNIT: Tuning Unit TN-3/APR-1**

Reference Symbol	Navy Stock No.	Name of Part and Description	Function	Mfr. and Desig. or AWS Type	Cont. or Gov't Dwg. or Spec. No.
R-402	R16-R-17313-20SM	RESISTOR: fixed, carbon; 25,000 ohms, $\pm 10\%$ , 1/2 watt, insulated; 7/16" long, .218" diameter; axial leads 1 1/2" long.	Grid leak.	12 BT-1/2 Ins.	6B5633
R-403	R16-R-17318-225L	RESISTOR: fixed, carbon; 27,000 ohms, $\pm 10\%$ , 1 watt, insulated; 3/4" long, .281" diameter; axial leads 1 1/2" long.	Plate dropping.	33 #518 Ins. 23 MB-1 Ins.	6B6427
R-404		ASSEMBLY, I-F RESISTOR: #33 nichrome wire, 2 5/8" long; wire enclosed in vinylite, 1 1/8" long, .080" diameter; brass shield: 1" long, 1/8" outside diameter, .020" thick wall; 3 ohm.	Parasitic suppressor.	1	1A60961
R-405	R16-R-18620-50	RESISTOR: fixed, wire wound; 42 ohms, $\pm 10\%$ , 5 watt; ceramic insulation; 1/32" long, 7/16" diameter, 2 radial terminal lugs.	Filament.	27	17A101038
R-406	R16-R-17268-20SM	RESISTOR: fixed, carbon; 1500 ohms, $\pm 10\%$ , 1/2 watt, insulated; 7/16" long, .218" diameter; axial leads 1 1/2" long.	I-F load.	12 23 33	6B5684
R-407		RESISTOR: same as R-101.	D-C by-pass to ground.		
V-401	16-T-69550	RADIO TUBE: type RMA #955 triode.	Oscillator.	42	
X-401	R16-GV-9A60820	RECEPTACLE, PLUG: brass, white nickel plated; 1/4-28 thread, 1/2" long, 3/8" diameter hexagonal head; .169" diameter hole.	B+ receptacle.	1	9A60820
X-402		RECEPTACLE, PLUG: same as X-401.	Filament receptacle.		
X-403		RECEPTACLE, PLUG: same as X-401.	28 V. D-C power receptacle.		
Y-401	R16-GV-48X42126	CRYSTAL, SILICON: overall dimensions: 9/16" long, 9/32" diameter.	Mixer and detector.	47 IN-21	48X42126

TABLE OF REPLACEABLE PARTS  
MODEL: Radio Receiving Equipment AN/APR-1 and AN/SPR-1

MAJOR UNIT: Tuning Unit TN-2/APR-1

Reference Symbol	Navy Stock No.	Name of Part and Description	Function	Mft. and Desig. or AWS Type	Cont. or Gov't Dwg. or Spec. No.
A-501		ASSEMBLY, HOUSHING BUSHING: same as A-401.	Mount knob shaft gear.	1	51X100781
A-502		ASSEMBLY, TUNER PANEL STAKED: panel: aluminum; 7.531" long, 6.281" wide, .125" thick; punched for parts mounting; pinion stud: stainless steel, 1/2" diameter, 1" long, one end tapped 6-32 thread, 1/2" deep; idler gear stud; stainless steel, 1/2" diameter, 29/32" long, one end tapped 6-32 thread; dial shaft bushing: aluminum, 7/8" diameter, 1 1/32" high, .4365" diameter hole.	Parts mounting.	1	
A-503		ASSEMBLY, TUNER PANEL COVER: same as A-403, except for lettering.	Front panel cover assembly.	1	
A-504		ASSEMBLY, TUNER UNIT HOUSING: composed of: tuner housing O-524, shaft and worm assembly O-505, ball bearing O-508, bearing adjustment sleeve collar O-515, bearing adjustment bracket A-517, screw H-540, screw H-541, threaded adjustment bushing A-514, set-screw H-550, ball bearing O-509, bearing retainer plate A-521, screw H-542, alignment panel pin O-530.	Tuner housing assembly.	1	51X101001
A-505		BRACKET, ANTENNA COIL MOUNTING: same as A-430.	Mount I-F coil L-501.		
A-506		BRACKET, CAM TRACK: same as A-407.	Mount cam track spring.		
A-507		BRACKET, HOLD-DOWN: same as A-311.	Fasten turner and shock mount.		
A-508		BRACKET, SPRING RETAINER: same as A-410.	Fasten pointer spring.		
A-509		BRACKET, SPRING RETAINER: same as A-411.	Fasten rotor link anti-backlash spring.		
A-510		BRACKET, TUBE: brass, silver plated; L shaped T; overall dimensions: 1" x 1 1/32" x 1" x 3/8".	Mount tube V-501.	1	7A60881
A-511		BUSHING, RECEPTACLE: same as A-409.	Chassis plug bushing.		
A-512		BUSHING, OPERATING CAM: same as O-411.	Mount operating cam.		
A-513		BUSHING, THREADED: same as A-314.	Mount cover.		
A-514		BUSHING, THREADED ADJUSTMENT: same as O-412.	Bearing retainer.		
A-515		CLAMP, ADJUSTING SCREWS: phosphor bronze, nickel plated; 27/32" long, 3/8" wide, .022" thick stock; 9 holes .148" diameter.	Adjusting screw clamp.	1	42A60888
A-516		CLAMP, CABLE: same as A-413.	Fasten antenna lead-in.		
A-517		BRACKET, BEARING ADJUSTMENT: same as A-406.	Bearing retainer.		
A-518		COLLAR, STOP: same as O-416.	Dog washer retainer and stop.		
A-519		COVER, TUNER PANEL: same as A-417.	Cover.		
A-520		COVER, TUNER ADJUSTMENT SCREW: same as A-416.	Compensator screw cover.		

TABLE OF REPLACEABLE PARTS  
MODEL: Radio Receiving Equipment AN/APR-1 and AN/SPR-1

Reference Symbol	Navy Stock No.	Name of Part and Description	Function	Mfr. and Desig. or AWS Type	Cont. or Gov't Dwg. or Spec. No.
A-521		PLATE, BEARING RETAINER: same as A-419.	Front bearing retainer.	1	64C60854
A-522		PLATE, COVER (BOTTOM): same as A-421.	Bottom cover.		
A-523		PLATE, COVER (TOP): aluminum, 10 <sup>3</sup> / <sub>16</sub> " long, 6 <sup>3</sup> / <sub>8</sub> " wide, .062" thick; 7 holes .116" diameter.	Top cover.		
A-524		SPACER, VARIABLE CAM TRACK: same as A-427.	Cam track spring spacer.		
A-525		ASSEMBLY; ALIGNMENT TOOL: same as A-301.	Alignment tool.		
C-501		PLATE, GRID CAPACITOR: brass, white silver plated; 1 <sup>1</sup> / <sub>4</sub> " long, 5 <sup>7</sup> / <sub>8</sub> " wide, .032" thick, 2 holes .322" diameter.	Grid coupling.	1	64A60886
C-502		LUG, ANTENNA GRID CAP: brass, white silver plated; mounting end: 1 <sup>1</sup> / <sub>2</sub> " diameter, .225" diameter hole; rod: 1 <sup>1</sup> / <sub>8</sub> " wide, 2 <sup>1</sup> / <sub>8</sub> " long, .032" thick.	R.F. by-pass.	1	29A60830
C-503		CAPACITOR: same as C-102.	Coupling.		
C-504		CAPACITOR: same as C-101.	By-pass.		
C-505		WASHER, CAPACITOR: same as C-409.	B+ by-pass.		
C-506		WASHER: CAPACITOR: same as C-409.	Filament by-pass.		
C-507		WASHER, CAPACITOR: same as C-409.	Hash filter.		
E-501	R16-GV-51X101004	ASSEMBLY, ANTENNA BUTTERFLY AND SOCKET: composed of: antenna butterfly assembly IC-502, antenna grid dielectric E-508, antenna grid cap lug C-502, grid capacitor insulator E-513, washer H-562, lockwasher H-503, nut H-518, tube socket spacer E-519, socket X-505, tube socket mounting washer E-523, washer H-565, lockwasher H-504, and nut H-518.	Antenna butterfly assembly.	1	51X101004
E-502		ASSEMBLY, OSCILLATOR BUTTERFLY AND BARS: composed of oscillator butterfly assembly LC-501, insulator grid bar E-571, grid capacitor plate C-501, grid bar washer E-522, grid bar insulator E-512, grid bar E-504, washer H-565, lockwasher H-504, nut H-518, plate bar E-505, lockwasher H-504, tube clip E-507, lockwasher H-505, screw H-544, soldering lug E-517, lockwasher H-507, screw H-528, and resistor R-502.	Oscillator tank circuit.	1	51X101003
E-503		ASSEMBLY, TUBE BRACKET AND CLIPS: composed of tube bracket A-510, filament clip insulator E-509, filament clip insulator E-510, tube clip E-507, lockwasher H-505, screw H-544, screw H-546, and nut H-521.	Mount tube V-501.	1	1X101005
E-504		BAR, GRID: brass, silver plated, "Z" shaped, overall dimensions: 1 <sup>25</sup> / <sub>32</sub> " long, 1 <sup>9</sup> / <sub>32</sub> " high, 1 <sup>1</sup> / <sub>4</sub> " thick; 2 holes .158" diameter, 1 hole tapped 6-32 thread, 1 hole tapped 2-56 thread.	Tube mounting.	1	46A60824

TABLE OF REPLACEABLE PARTS

MODEL: Radio Receiving Equipment AN/APR-1 and AN/SPR-1

MAJOR UNIT: Tuning Unit TN-2/APR-1

Reference Symbol	Navy Stock No.	Name of Part and Description	Function	Mfr. and Desig. or AWS Type	Cont. or Gov't Dug. or Spec. No.
E-505		BAR PLATE: same as E-405.	Mount tube.		
E-506		CABLE, COAXIAL: #18 solid bare copper wire; 3/64" wall, copolene insulation shielded with seamless copper tubing, silver plated, 1.4 1/2" long, bent to fit.	Antenna plug lead-in.	1	30C101097
E-507		CLIP, TUBE: same as E-407.	Mount tubes.		
E-508	R16-GV-14A60878	DIELECTRIC, ANTENNA GRID: clear India ruby mica; 5/8" square, .008" thick, 1 hole .152" diameter.	Capacitor C-502 dielectric.	1	14A60878
E-509		INSULATOR, FILAMENT CLIP: same as E-412.	Tube bracket insulator.		
E-510		INSULATOR, FILAMENT CLIP: same as E-413.	Tube bracket insulator.		
E-511	R16-GV-14A60925	INSULATOR, GRID BAR: clear India ruby mica; 1 1/2" long, 13/16" wide, .004" thick, 2 holes .158" diameter.	Insulator.	1	14A60925
E-512	R16-GV-14A60876	INSULATOR, GRID BAR: phenolic, grade XX; .148" outside diameter, .106" inside diameter, .415" long.	Insulator.	1	14A60876
E-513	R16-GV-14A60879	INSULATOR, GRID CAPACITOR: phenolic grade XX; 11/32" outside diameter, 1/32" thick, .101" diameter hole; collar: .025" high, .153" inside diameter, .220" outside diameter.	Fasten capacitor C-502.		
E-514		INSULATOR, RECEPTACLE: same as E-417.	Capacitor insulator.		
E-515		INSULATOR, RECEPTACLE: same as E-416.	Dielectric.		
E-516		INSULATOR, RECEPTACLE: same as E-418.	Banana plug insulator.		
E-517		LUG, SOLDERING: same as E-103.	Tie point.		
E-518		LUG, SOLDERING: brass, hot tinned dipped; wire hole .080" diameter, mounting hole .144" diameter.	Tie point.	22 #2522-6	29K5261
E-519		SPACER, TUBE SOCKET: phenolic, grade MF; 5/16" outside diameter, 7/16" long; .156" diameter hole, 1/16" deep; .103" diameter hole 1/2" deep.	Mount tube socket V-502.	1	46A60307
E-520		TERMINAL STRIP: same as E-432.	Tie point.		
E-521		TERMINAL STRIP: same as E-430.	Tie point.		
E-522	R16-GV-4A60877	WASHER, GRID BAR: phenolic, grade XX; .312" outside diameter, .152" inside diameter, .062" thick.	Insulator.	1	4A60877
E-523	R16-GV-4A101036	WASHER, TUBE SOCKET MOUNTING: phenolic, grade XX; 1/4" outside diameter, .109" inside diameter, .050" thick.	Fasten tube socket, V-502.	1	A101036
E-524		LUG, SOLDERING: same as E-422.	Tie point.		

MAJOR UNIT: Tuning Unit TN-2/APR-1

TABLE OF REPLACEABLE PARTS

MODEL: Radio Receiving Equipment AN/APR-1 and AN/SPR-1

Reference Symbol	Navy Stock No.	Name of Part and Description	Function	Mfr. and Desig. or AWS Type	Cont. or Gov't Dwg. or Spec. No.
E-525		TERMINAL STRIP: same as A-113.	Tie point.		30A101848
E-526		CABLE, SHIELDED: single conductor of #20 (.0320) A.W.G. solid copper wire, normal impedance 51 ohms; 4.750" long x .218" diameter; inner covering stabilized Polyethylene; American Phenolic Corp. (shield braid of tinned copper wire; outer covering black vinylite).	B+ cable.		
H-501		HANDLE: same as H-402.	Tuner handle.		
H-502		LOCK WASHER: same as H-403.	Mount cam track.		
H-503		LOCK WASHER: same as H-404.	General.		
H-504		LOCK WASHER: same as H-406.	General.		
H-505		LOCK WASHER: same as H-407.	Fasten tube clips.		
H-506		LOCK WASHER: same as H-408.	General.		
H-507		LOCK WASHER: same as H-409.	Fasten soldering lug.		
H-508		LOCK WASHER: same as H-410.	General.		
H-509		LOCK WASHER: same as H-306.	Mount housing bushing.	32	4S9728
H-510		LOCK WASHER: #6 internal, 5/16" outside diameter, .018" thick; spring steel, black nickel finish.	Mount housing bushing.	#1106	
H-511		LOCK WASHER: 5/16" diameter, internal, 9/16" outside diameter, .030" thick, spring steel, white cadmium plated.	Mount coil L-501.	22	4S7674
H-512		NUT: same as H-208.	Mount hold-down bracket.		
H-513		NUT: same as H-317.	Mount terminal strip.		
H-514		NUT: same as H-416.	Mount cam rollers.		
H-515		NUT, HEX: same as H-319.	Mount chassis plug bushing.		
H-516		NUT: same as H-420.	Mount receptacles X-501, X-502, X-503.		
H-517		NUT, DRIVE SHAFT: same as H-421.	Mount housing bushing.		
H-518		NUT: same as H-422.	General.		
H-519		NUT, CAP: same as H-423.	Antenna feed-thru.		
H-520		NUT: same as H-102.	General.		
H-521		NUT: same as H-417.	Fasten tube clip.		
H-522		NUT: 5/16"-2.4 thread, 1/2" diameter, hexagonal, 3/32" thick, steel, white nickel finish.	Mount coil L-501.	26	2S8383

MODEL: Radio Receiving Equipment AN/APR-1 and AN/SPR-1		TABLE OF REPLACEABLE PARTS			MAJOR UNIT: Tuning Unit TN-2/APR-1		
Reference Symbol	Navy Stock No.	Name of Part and Description	Function	Mfr. and Desig. or AWS Type	Cont. or Gov't Dwg. or Spec. No.		
H-523		RIVET: same as H-427.	Fasten dial lock assembly.				
H-524		RIVET, SHOULDER: same as H-429.	Fasten compensator screw cover.				
H-525		RIVET, CAM ROLLER LINK: same as H-428.	Fasten helical gear to link.				
H-526		SCREW: 8-32 thread, 1/4" long, slotted flat head, brass, white nickel plated.	Mount tube bracket.	26	3S1295		
H-527		SCREW, VARIABLE CAM ADJUSTMENT: stainless steel, 6-32 thread, 1" long, slotted fillister head.	Adjust cam track.	1	3A60832		
H-528		SCREW: same as H-334.	Fasten soldering lug.				
H-529		SCREW: 4-40 thread, 3/8" long, slotted round head, brass, white nickel plated.	Mount cam track.	26	3S8023		
H-530		SCREW: 4-40 thread, 3/16" long, slotted round head, brass, white nickel plated.	Mount cam track.	26	3S1294		
H-531		SCREW: 6-32 thread, 5/16" long, slotted round head, brass, white nickel plated.	General.	1	3S1264		
H-532		SCREW: same as H-447.	General.				
H-533		SCREW: same as H-451.	Front panel mounting.				
H-534		SCREW: same as H-444.	Fasten handle and cover to housing.				
H-535		SCREW: same as H-433.	Fasten tuner dial.				
H-536		SCREW: same as H-432.	General.				
H-537		SCREW: same as H-446.	Fasten antenna lever on antenna rotor arm.				
H-538		SCREW: same as H-104.	Gear assembly.				
H-539		SCREW: same as H-450.	Fasten backing plate.				
H-540		SCREW: same as H-448.	Mount bearing adjustment bracket.				
H-541		SCREW: same as H-452.	Fasten bearing retainer.				
H-542		SCREW: same as H-449.	Mount bearing retainer plate.				
H-543		SCREW: same as H-436.	Fasten top and bottom covers.				
H-544		SCREW: same as H-440.	Fasten tube clips.				
H-545		SCREW: same as H-462.	General.				

TABLE OF REPLACEABLE PARTS  
MODEL: Radio Receiving Equipment AN/APR-1 and AN/SPR-1

MODEL: Radio Receiving Equipment AN/APR-1 and AN/SPR-1		MAJOR UNIT: Tuning Unit TN-2/APR-1			
Reference Symbol	Navy Stock No.	Name of Part and Description	Function	Mfr. and Desig. or AWS Type	Cont. or Gov't Dwg. or Spec. No.
H-546		SCREW: same as H-441.	Fasten tube clip.		
H-547		SCREW: same as H-211.	General.		
H-548		SCREW: same as H-445.	Fastens helical gear.		
H-549		SCREW: same as H-460.	Fasten hold-down bracket.		
H-550		SETScrew: same as H-453.	General.		
H-551		SETScrew: same as H-463.	Mount idler pinion gear.		
H-552		SETScrew: same as H-464.	Fasten tuner knob.		
H-554		STUD, COVER: same as H-481.	Mounting panel cover.		
H-555		STUD, PIVOT: same as H-466.	Mount capacitor operating cam.		
H-556		STUD, ROTOR LINK: same as H-467.	Fasten cam link to lever and cam.		
H-557		STUD, SPINNER KNOB: same as H-468.	Fasten knob handle.		
H-558		WASHER: same as H-474.	Gear retainer.		
H-559		WASHER, HANDLE: same as H-476.	Fasten handle.		
H-560		WASHER, SPRING: same as H-478.	Tuning knob stop release.		
H-561		WASHER, DIAL SHAFT: same as H-480.	Dial shaft washer.		
H-562		WASHER: same as H-475.	Fasten capacitor C-502 and tube socket V-502.		
H-563		WASHER: same as H-470.	Roller washer.		
H-564		WASHER SPRING: same as H-479.	Fasten handle.		
H-565		WASHER: same as H-475.	Fasten grid bar.		
H-566		WASHER, DRIVE GEAR: stainless steel $2\frac{1}{32}$ " outside diameter, $.312$ " inside diameter, $.062$ " thick.	Mount drive gear.	1	4A60312
H-567		LOCK WASHER: same as H-482.			
H-568		WRENCH, ALLEN: same as H-345.	For 6-32 screws.		
H-569		WRENCH, ALLEN: same as H-346.	For 8-32 screws.		
L-501		COIL, I.F.: same as L-407.	I.F. coil.		
LC-501		ASSEMBLY, OSCILLATOR BUTTERFLY: aluminum; variable; 8 rotor plates, 9 stator plates, overall dimensions: $4\frac{1}{4}$ " diameter; $3\frac{1}{8}$ " high.	Oscillator tank circuit.	1	51C100779

TABLE OF REPLACEABLE PARTS  
MAJOR UNIT: Tuning Unit TN-2/APR-1  
MODEL: Radio Receiving Equipment AN/APR-1 and AN/SPR-1

Reference Symbol	Navy Stock No.	Name of Part and Description	Function	Mfr. and Desig. or AWS Type	Cont. or Gov't Dwg. or Spec. No.
LC-502		ASSEMBLY, ANTENNA BUTTERFLY: aluminum; variable; 7 rotor plates, 8 stator plates; 4 1/2" outside diameter, 3" high.	Antenna tank circuit.	1	51C100778
N-501		DIAL, TUNER: same as N-401, except for frequency scale.	Dial scale reading in megacycles.		34B104609
O-501		ASSEMBLY, BACKING PLATE AND DIAL INDICATOR: same as O-401.	Dial indicator assembly.	1	1X101006
O-502		ASSEMBLY, CAM LINK AND LEVER: composed of: capacitor operating cam O-513, antenna rotor cam link O-528, antenna rotor lever O-527, rotor link stud H-556, screw H-537.	Rotate antenna butterfly.		
O-503		ASSEMBLY, HELICAL GEAR AND LINK: same as O-403.	Oscillator butterfly gear assembly.		
O-504		ASSEMBLY, PINION AND GEARS: composed of: backlash gear O-518, backlash gear O-519, idler pinion O-533, and compression coil spring O-547.	Gear assembly.	1	1X100760
O-505		ASSEMBLY, SHAFT AND WORM: same as O-404.	Part of tuning gear assembly.		
O-506		ASSEMBLY, SPINNER KNOB: same as O-405.	Tuner knob assembly.		
O-507		ASSEMBLY, SPINNER LOCK: same as O-406.	Handle shaft lock.		
O-508		BALL BEARING, DOUBLE SEAL: Fafnir #3.8LL metal; overall dimensions: .562" outside diameter, .8659" high.	Shaft bearing.	38	43A100736
O-509		BALL BEARING, SINGLE SEAL: Fafnir #38L metal; overall dimensions: .406" outside diameter, .8659" high.	Drive shaft bearing.	38	43A100737
O-510		BEARING, OILITE: same as O-408.	Gear bearing.		
O-511		BEARING, OILITE: same as O-409.	Gear mounting.		
O-512		BEARING, OPERATING CAM: same as O-410.	Capacitor operating cam bearing.		
O-513		CAM, CAPACITOR OPERATING: stainless steel; tapered; overall dimensions: 5/8" long, 2 1/2" wide, .064" thick; mounting hole, .500" diameter.	Vary antenna butterfly tuning.	1	45C60838
O-514		CAP, PLUG: aluminum: 3/4-20 thread tapped, 7/8" outside diameter, hexagonal, 3/4" high, 1/4-28 thread tapped hole on top of cap.	Mount antenna lead-in.	49	15A60942
O-515		COLLAR, BEARING ADJUSTMENT SLEEVE: same as O-414.	Spacer for dog washer stop plate.		
O-516		COLLAR, DRIVE SHAFT: same as O-415.	Shaft retainer and spring tension adjustment.		
O-517		DISC, SPINNER KNOB: same as O-418.	Locking disc.		
O-518		GEAR, BACKLASH: same as O-419.	Part of tuning gear assembly.		



**MODEL: Radio Receiving Equipment AN/APR-1 and AN/SPR-1**

TABLE OF REPLACEABLE PARTS		MAJOR UNIT: Tuning Unit TN-2/APR-1			
Reference Symbol	Navy Stock No.	Name of Part and Description	Function	Mfr. and Desig. or AWS Type	Cont. or Gov't Dwg. or Spec. No.
O-519		GEAR, BACKLASH: same as O-422.	Part of tuning gear assembly.		
O-520		GEAR, BACKLASH: same as O-421.	Tuning gear on dial shaft.		
O-521		GEAR, BACKLASH: same as O-420.	Tuning gear on dial shaft.		
O-522		GEAR, HELICAL: same as O-423.	Vary oscillator butterfly.		
O-523		HANDLE, KNOB: same as O-424.	Knob handle.		
O-524		HOUSING, TUNER: cast aluminum; 10 <sup>3</sup> / <sub>16</sub> " long, 6 <sup>3</sup> / <sub>16</sub> " high, 5.187" wide; punched and tapped for parts mounting.	Tuner housing.	1	62E60855
O-525		HUB, DIAL: same as O-425.	Mount dial shaft assembly.		
O-526		KNOB, SPINNER: same as O-426.	Tuner knob.		
O-527		LEVER, ANTENNA ROTOR: same as O-427.	Mounts on antenna rotor stud.		
O-528		LINK, ANTENNA ROTOR CAM: aluminum, 6" long, .437" wide, .091" thick; 2 holes .250" diameter.	Connect capacitor cam to rotor lever.	1	45A60757
O-529		LINK, CAM ROLLER: same as O-429.	Part of oscillator butterfly gear assembly.		
O-530		PIN, PANEL ALIGNMENT: same as H-424.	Front panel alignment.		
O-531		PINION, GEAR: same as O-431.	Part of tuning gear assembly.		
O-532		PINION: same as O-434.	Part of tuning gear assembly.		
O-533		PINION, IDLER: same as O-433.	Tuning gear assembly.		
O-534		PINION, IDLER: same as O-432.	Part of tuning gear assembly.		
O-535		PLATE, BACKING: same as O-438.	Mount dial indicator.		
O-536		PLATE, LOCKWASHER STOP: same as O-430.	Dog washer stop.		
O-537		POINTER, ADJUSTMENT: aluminum; L shaped; 1 leg to hole center 1 <sup>1</sup> / <sub>8</sub> " long; <sup>3</sup> / <sub>16</sub> " wide; 1 leg 1" long, 1/8" wide, center hole .188" diameter, 1 hole .057" diameter.	Cam screw adjustment pointer.	1	52A60734
O-538		PLUG, BANANA: same as E-426.	Plug P-501 and P-502 contact.		
O-539		ROLLER, VARIABLE CAM: same as O-437.	Cam track roller.		
O-540		ROLLER, CAM: same as O-436.	Antenna cam roller.		
O-541		SHAFT, CAM ROLLER: same as O-439.	Mount roller cams and pointer.		
O-542		SHAFT, DIAL: same as O-440.	Mounts dial.		

TABLE OF REPLACEABLE PARTS

MODEL: Radio Receiving Equipment AN/APR-1 and AN/SPR-1

MAJOR UNIT: Tuning Unit TN-2/APR-1

Reference Symbol	Navy Stock No.	Name of Part and Description	Function	Mfr. and Desig. or AWS Type	Cont. or Gov't Dwg. or Spec. No.
O-543		SHAFT, HAND WHEEL: same as O-441.	Mount tuning knob; part of tuning gear assembly.		
O-544		SPACER, BACKING PLATE: same as O-443.	Backing plate spacer.		
O-545		SPACER, INDICATOR: same as O-446.	Indicator spacer.		
O-546		SPRING, CAM TRACK: same as O-449.	Cam track roller spring.		
O-547		SPRING, COMPRESSION COIL: .015" diameter music wire; 7 1/2 turns, ends closed, 1/8" outside diameter, 1/2" long.	Anti-backlash spring.	1	41A19931
O-548		SPRING, OPERATING CAM: same as O-452.	Operating cam spring.		
O-549		SPRING, POINTER ADJUSTMENT: same as O-453.	Pointer adjustment spring.	1	41A60738
O-550		SPRING, RETAINER: same as O-454.	Banana plug insulator retainer.		
O-551		SPRING, RETAINER: same as O-455.	Insulator banana plug retainer.		
O-552		WASHER, DOG: same as O-456.	Drive shaft stop.		
O-553		WINDOW, DIAL: same as A-428.	Dial window.		
O-554		SPRING, CAM ARM: stainless steel wire .030" diameter; 3 turn coil, .312" inside diameter; arms 60° apart; loops on arms, 45°; small rectangular loop, .375" x .062" inside diameter; large rectangular loop, .125" x .343" inside diameter; overall dimensions; 1.187" x .281" x .437".	Cam arm spring.	1	41A107298
O-555		ASSEMBLY, HELICAL GEAR, LINK AND ROLLER: composed of gear O-522, link O-529, and cam link O-528.	Oscillator butterfly gear assembly.	1	1X103965
P-501		PLUG, CHASSIS: same as P-401.	Antenna plug.		
P-502		PLUG, CHASSIS: same as P-401.	I-F plug.		
R-501		RESISTOR: same as R-403.	Plate drooping.		
R-502		RESISTOR: same as R-402.	Grid leak.		
R-503		RESISTOR: same as R-406.	I-F load.		
R-504		RESISTOR: same as R-101.	Diode bias.		
V-501		RADIO TUBE: Type RMA #955 triode.	Oscillator.	42 #955	
V-502		RADIO TUBE: Type RMA #955 triode.	Mixer.		
X-501		RECEPTACLE, PLUG: same as X-401.	B+ receptacle.		
X-502		RECEPTACLE, PLUG: same as X-401.	Filament receptacle.		

**TABLE OF REPLACEABLE PARTS**  
**MODEL: Radio Receiving Equipment AN/APR-1 and AN/SPR-1**

**MAJOR UNIT: Tuning Unit TN-2/APR-1**

Reference Symbol	Navy Stock No.	Name of Part and Description	Function	Mfr. and Desig. or AWS Type	Cont. or Gov't Dwg. or Spec. No.
X-503		RECEPTACLE, PLUG: same as X-401.	28 volt d-c power receptacle.	1	9A101085
X-504		SOCKET, ISOLANTITE: phosphor bronze, silver plated, 5 snap edge type contacts; base: 1 $\frac{9}{16}$ " diameter, $\frac{3}{16}$ " thick.	Mount tube V-502.		

TABLE OF REPLACEABLE PARTS  
MODEL: Radio Receiving Equipment AN/APR-1 and AN/SPR-1 MAJOR UNIT: Tuning Unit TN-1/APR-1

Reference Symbol	Navy Stock No.	Name of Part and Description	Function	Mfr. and Desig. or AWS Type	Cont. or Gov't Dwg. or Spec. No.
A-601		ASSEMBLY, BRACKET AND BUSHING: aluminum bracket, L shaped, .091" thick stock, 6 <sup>1</sup> / <sub>16</sub> " long, 2 <sup>3</sup> / <sub>4</sub> " wide, 1/2" high; punched for parts mounting; I-F coil bushing fastened to bracket.	Parts mounting.	1	1X104725
A-602		ASSEMBLY, HOUSING BUSHING: same as A-401.	Mount knob shaft and gear.		
A-603		ASSEMBLY, MOUNTING STRIP AND BUSHING: phenolic strip, 1/8" thick, 3 <sup>1</sup> / <sub>8</sub> " long, 1/8" wide; 2 bushings: .187" square, .175" high, 4-40 thread; 4 holes .152" diameter.	Filter strip parts mounting.	1	1X109231
A-604		ASSEMBLY, TUNER PANEL STAKED: panel: aluminum #24ST, .125" thick, 7.531" long, 6.281" wide; pinion stud: stainless steel, overall dimensions: 1/2" diameter, 1" long, one end tapped 6-32 thread, 1/2" deep; idler gear stud: stainless steel, overall dimensions: 1/2" diameter, 29 <sup>3</sup> / <sub>32</sub> " long, one end tapped 6-32 thread; dial shaft bushing: aluminum, 7/8" diameter, 1 <sup>1</sup> / <sub>32</sub> " high, .4365" diameter hole; stop studs: brass, white nickel plated, overall dimensions: 1 <sup>1</sup> / <sub>16</sub> " long, 5/16" diameter.	Parts mounting.	1	51X104682
A-605		BRACKET, HOLD-DOWN: same as A-311.	Hold tuner in shock-mount.		
A-606		BRACKET, TUNING ASSEMBLY (R.H.): aluminum, .091" thick stock; L shaped; 6 <sup>1</sup> / <sub>16</sub> " long, 2 <sup>3</sup> / <sub>4</sub> " wide, 1/2" high; punched for parts mounting.	Parts mounting.	1	7B103718
A-607		CLAMP, CABLE: cold rolled steel, cadmium plated; hook shaped; .180" diameter mounting hole; .031" thick stock; overall dimensions: 25 <sup>5</sup> / <sub>32</sub> " long, 5/16" wide, 5/16" high.	Fasten leads.	1	42A48816
A-608		CLAMP, CABLE: same as A-414.	Fasten cable.		
A-609		COVER, TUNER PANEL: aluminum, black wrinkle finish; 6.374" wide, 7.624" long, 1.2964" high, .062" thick stock; drilled and punched for parts mounting.	Front panel of tuner.	1	15B103744
A-610		HOUSING, TUNER: cast aluminum; 10 <sup>3</sup> / <sub>16</sub> " long, 6 <sup>3</sup> / <sub>8</sub> " high, 5.187" wide; punched and tapped for parts mounting.	Tuner housing.	1	62E103708
A-611		PLATE, COVER (BOTTOM): aluminum; 10 <sup>3</sup> / <sub>16</sub> " long, 6 <sup>3</sup> / <sub>8</sub> " wide, .062" thick; 7 holes .116" diameter countersunk.	Tuner cover.	1	64C104645
A-612		PLATE, COVER (TOP): aluminum 3S; 10 <sup>3</sup> / <sub>16</sub> " long, 6 <sup>3</sup> / <sub>8</sub> " wide, .062" thick; 7 holes .116" diameter countersunk.	Tuner cover.		64C60854
A-613		SLEEVE, RUBBER: same as A-206.	Cable protector.		
A-614		SLEEVE, RUBBER: same as A-423.	Cable protection.		
A-615		SPACER, VARIABLE CAM TRACK: same as A-424.	Mount terminal strip and cam track.		
A-616		WINDOW, DIAL: same as A-428.	Dial window.		
A-617		ASSEMBLY ALIGNMENT TOOL: same as A-301.	Alignment tool.		

TABLE OF REPLACEABLE PARTS

MODEL: Radio Receiving Equipment AN/APR-1 and AN/SPR-1

MAJOR UNIT: Tuning Unit TN-1/APR-1

Reference Symbol	Navy Stock No.	Name of Part and Description	Function	Mfr. and Desig. or AWS Type	Cont. or Gov't Dwg. or Spec. No.
C-601	R16-C-9974-1-100	CAPACITOR: fixed, mica; 250 micro-microfarads, $\pm 10\%$ , 400 V. D-C working; color coded: red, green, brown, silver; $1\frac{1}{16}$ " long, $\frac{1}{16}$ " wide, $\frac{1}{64}$ " thick; axial leads.	Oscillator plate coupling.	2 #1468X	21B6662
C-602		CAPACITOR: same as C-131.	Grid coupling.		
C-603	R16-C-11888-500	CAPACITOR: variable; 2 stator plates, 2 rotor plates; minimum capacity: 2 to 4 micro-microfarads; maximum capacity; 7 to 9 micro-microfarads; overall dimensions: $1\frac{5}{16}$ " long, 1" wide, 1" high; mounting bushing: $\frac{5}{16}$ -32 thread, $\frac{7}{32}$ " long.	Oscillator trimmer.	1	19A103714
C-604		CAPACITOR: same as C-603.	R-F trimmer.		
C-605	R16-C-11937	CAPACITOR: variable; 2 section gang; 13 rotor plates, 12 stator plates; each section 8.5 micro-microfarads to 120 micro-microfarads; overall dimensions: 4.361" long, 2.906" high, 1.625" wide. (Part of C-606.)	Tuning capacitor.	1	19C103716
C-606		CAPACITOR: 1 section of C-605.	Tuning capacitor.		
C-607	R16-C-12085-500	CAPACITOR: variable, 13 rotor plates, 15 stator plates; minimum capacity: 145 micro-microfarads, maximum capacity: 208 micro-microfarads; overall dimensions: $2\frac{1}{2}$ " long, $1\frac{5}{16}$ " high, $2\frac{9}{32}$ " wide; bracket mounting.	Oscillator padder.	1	19A103715
C-608		CAPACITOR: same as C-407.	Cathode by-pass.		
C-609		CAPACITOR: same as C-407.	Coupling.		
C-10	R16-C-10018-121	CAPACITOR: fixed, mica; 5,000 micro-microfarads, $\pm 20\%$ , 500 V. D-C working; color coded: green, black, orange; $2\frac{5}{32}$ " square, $\frac{1}{4}$ " thick; axial leads.	R-F by-pass.	2 #1467	21B6643
C-611		WASHER, CAPACITOR: same as C-409.	Filament by-pass.		
C-612		WASHER, CAPACITOR: same as C-409.	B+ by-pass.		
C-613		WASHER, CAPACITOR: same as C-409.	Hash filter.		
C-614		CAPACITOR: fixed, mica; 200 micro-microfarads, $\pm 10\%$ , 400 V. D-C working; color coded: green, black, brown, silver; $1\frac{1}{16}$ " long, $\frac{1}{16}$ " wide, $\frac{1}{64}$ " thick; axial leads.	I-F trap.	2 #1468	21B6552
C-615		CAPACITOR: same as C-614.	I-F trap.		
E-601		CABLE, COAXIAL: #18 solid bare copper wire; $\frac{3}{64}$ " wall, copolene insulation shielded with seamless copper tubing, silver plated; $8\frac{3}{4}$ " long, bent to fit mounting location.	Antenna cable.	1	30A109121
E-602		CABLE, SHIELDED: #20 A.W.G. solid copper wire, polyethylene dielectric covering, shield of braided tinned copper wire, black vinylite cover, $7\frac{3}{8}$ " long.	I-F cable.	1	30A104714
E-603		INSULATOR: same as E-417.	Capacitor insulator, C-611, C-612, C-613.		

TABLE OF REPLACEABLE PARTS  
MODEL: Radio Receiving Equipment AN/APR-1 and AN/SPR-1 MAJOR UNIT: Tuning Unit TN-1/APR-1

Reference Symbol	Navy Stock No.	Name of Part and Description	Function	Mfr. and Desig. or AWS Type	Cont. or Gov't Dug. or Spec. No.
E-604		INSULATOR: same as E-416.	Capacitor dielectric, C-611, C-612, C-613.		29A28673
E-605		LUG, CONTACT: phosphor bronze, white silver plated; .0159" thick stock, L shaped, 1 hole .070" diameter, 1 hole .093" diameter, 1 hole .032" diameter; 2 1/64" long, .125" wide, .15" high.	Tie point.	1	
E-606		LUG, SOLDERING: same as E-422.	Tie point.		
E-607		LUG, SOLDERING: #8 mounting hole, wire hole .164-.174" diameter, .020" copper, hot tinned, dumb-bell type.	Tie point.	29	29K5379
E-608		LUG, SOLDERING: #4 mounting hole, wire hole .110-.123" diameter, .025" brass, Cinch solder plated, U shaped.	Tie point.	9 #1477	29K5377
E-609		LUG, SOLDERING: #5 mounting hole, wire hole .129-.136" diameter, .026" brass, hot tinned, plain bent.	Tie point.	22 #2585-5-1	29K5378
E-610		SLUG, I.F. COIL: brass, silver plated; 1 13/32" long, 6-32 thread, screwdriver slot on end.	Tuning slug for L-601.	1	46A104719
E-611		TERMINAL STRIP: bakelite, 1/16" thick, 3/8" wide, 25/32" long, 1 Cinch lug #X1464 and 1 Cinch lug #2494.	Tie point.	9	31A31217
E-612		TERMINAL STRIP: same as E-432.	Tie point.		
E-613		TERMINAL STRIP: phenolic; .062" thick, 7/8" square; 4 terminals Cinch #1481; center bushing 5/16" square, 5/32" high, tapped 6-32 thread, stainless steel.	Tie point.	9	31A104668
E-614		TERMINAL STRIP: bakelite, 1/16" thick, 3/8" wide, 25/32" long; 1 Cinch lug #1464, 1 Cinch #1465.	Tie point.	9	31A31216
E-615		ASSEMBLY, ANTENNA FILTER: composed of mounting strip and bushing assembly A-603, terminal E-611, TN-1 filter coil, L-603, and TN-1 filter coil L-604.	Filter	1	1X104709
E-616		BOARD, ANTENNA FILTER MOUNTING: Phenolic grade "LE" natural; 3.125" long x .875" high x .125" thick; Galvin special; (has two (2) .328" diameter holes with .625" cavity on each 2.250" c/c; has four (4) holes .152" diameter).	Mount antenna filter.	1	14A104688
H-601		HANDLE: same as H-402.	Tuner handle.		
H-602		LOCKWASHER: same as H-403.	General.	22	4S9732
H-603		LOCKWASHER: same as H-409.	Fasten backing plate.		
H-604		LOCKWASHER: 1/4" internal, 15/32" outside diameter, .025" thick, phosphor bronze, white nickel plated.	Fasten receptacles X-601, X-602, X-603.	22	4S8409
H-605		LOCKWASHER: same as H-404.	General.		

TABLE OF REPLACEABLE PARTS  
MODEL: Radio Receiving Equipment AN/APR-1 and AN/SPR-1

MODEL: Radio Receiving Equipment AN/APR-1 and AN/SPR-1		MAJOR UNIT: Tuning Unit TN-1/APR-1			
Reference Symbol	Navy Stock No.	Name of Part and Description	Function	Mfr. and Desig. or AWS Type	Cont. or Gov't Dwg. or Spec. No.
H-606		LOCKWASHER: same as H-407.	Fasten tube sockets.		
H-607		LOCKWASHER: #8 external, 3/8" outside diameter, .020" thick; spring steel, white nickel plated.	Mount tuning brackets.	22	4S8448
H-608		LOCKWASHER: same as H-406.	Fasten tuner dial.		
H-609		LOCKWASHER: same as H-411.	Cover assembly.		
H-610		LOCKWASHER: same as H-405.	Mount housing bushing.		
H-611		NUT, HEX: brass, silver plate; 3/4-20 thread, 7/8" outside diameter, hexagonal, 5/32" thick.	Fasten antenna cable.	1	2K101970
H-612		NUT: same as H-102.			
H-613		NUT: same as H-420.	Fasten capacitors C-605 and C-606.		
H-614		NUT: same as H-417.	Fasten receptacles X-601, X-602, X-603.		
H-615		NUT: same as H-419.	Fasten tube sockets.		
H-616		NUT, CAP: same as H-423.	Cover assembly.		
H-617		NUT: same as H-206.	Antenna feed-thru.		
H-618		NUT: same as H-208.	Fasten terminal strip.		
H-619		NUT: 4-40 thread, 1/4" long, hexagonal head, brass, white nickel finish.	Fasten hold-down bracket.		
H-620		PIN, STOP: stainless steel; 1 3/16" long, .125" diameter.	Fasten tube retainer assembly.	26	2S8362
H-621		RIVET: same as H-427.	Tuning mechanism stop.	1	47A103816
H-622		RIVET: .088" diameter, 3/16" long, oven head, cold rolled steel, black nickel finish.	Fasten dial lock assembly.		
H-623		SETSCREW: same as H-464.	Fasten dial window.	24	5S7786
H-624		SETSCREW: same as H-453.	Fasten tuner knob.	S1727-3	
H-625		SCREW: same as H-460.	General.		
H-626		SCREW: same as H-104.	Fasten hold-down bracket.		
H-627		SCREW: 3-48 thread, 3/16" long, slotted binder head, brass, white nickel plated.	General.		
H-628		SCREW: same as H-346.	Fasten tuner dial.	26	3S1866
H-629		SCREW: same as H-451.	General Cover assembly.		

TABLE OF REPLACEABLE PARTS  
MODEL: Radio Receiving Equipment AN/APR-1 and AN/SPR-1

MAJOR UNIT: Tuning Unit TN-1 / APR-1

Reference Symbol	Navy Stock No.	Name of Part and Description	Function	Mfr. and Desig. or AWS Type	Cont. or Gov't Dwg. or Spec. No.
H-630		SCREW: same as H-444.	Fasten handle and housing to cover.		
H-631		SCREW: same as H-434.	Fasten dial indicator.		
H-632		SCREW: same as H-452.	Mount terminal strip filter assembly.		
H-633		SCREW: same as H-459.	Cover assembly.	26	3S1289
H-634		SCREW: 4-40 thread, 5/16" long, slotted round head, brass, white nickel plated.	Fasten tube retainer assembly.		
H-635		SCREW: same as H-211.	Fasten terminal strip.		
H-636		SCREW: 6-32 thread; 5/16" long, slotted round head, brass, white nickel plated.	Fasten terminal strip.	26	3S9660
H-637		SCREW: same as H-430.	Fasten terminal strip.		
H-638		SCREW: 4-40 thread, 3/8" long, slotted binder head, brass, black nickel finish.	Fasten handle.	26	3S1874.
H-639		SCREW: 2-56 thread, 1/4" long, slotted binder head, brass, white nickel plated.	Fasten tube sockets.	26	3S1970
H-640		SCREW: 4-36 thread, 3/8" long, slotted binder head, brass, white nickel plated.	Fasten capacitor C-607.	26	3S1969
H-641		SCREW: same as H-450.	Fasten backing plate.		
H-642		STUD, COVER: same as H-481.	Mount panel cover.		
H-643		STUD, SPINNER KNOB: same as H-468.	Fasten knob handle.		
H-644		WASHER: same as H-474.	Gear retainer.		
H-645		WASHER: same as H-473.	Fasten dial window.		
H-646		WASHER, DIAL SHAFT: same as H-480.	Dial shaft washer.	1	4A101095
H-647		WASHER, HANDLE: brass, white nickel plated; .032" thick, 9/16" outside diameter, .439" inside diameter.	Fasten handle.		
H-648		WASHER, SPRING: same as H-478.	Tuning knob stop release.		
H-649		SCREW: same as H-331.	Mount tuning brackets.	51	2A104721
H-650		NUT, LOCK: phosphor bronze; .012" thick, 15/32" diameter, white cadmium plated.	Mount coils.	B#593-A	



TABLE OF REPLACEABLE PARTS  
MODEL: Radio Receiving Equipment AN/APR-1 and AN/SPR-1

Reference Symbol	Navy Stock No.	Name of Part and Description	Function	Mfr. and Desig. or AWS Type	Cont. or Gov't Dwg. or Spec. No.
H-651		WRENCH, ALLEN: same as H-345.	For 6-32 screws.		
H-652		WRENCH, ALLEN: same as H-346.	For 8-32 screws.		
L-601		COIL, I.F.: 6 turns of #33 solid enameled copper wire on 3/8" diameter form; overall dimensions: 1 3/32" long, 1/2" diameter, 7/8" diameter including lugs; frequency of 30 megacycles, capacity of 55-65 micro-microfarads.	I-F coil.	51 #12888	24A103713
L-602		COIL, R.F. CHOKE: same as L-401.	Filament R-F choke.		
L-603		COIL, TN-1 FILTER: 3 1/2 turns #20 solid tinned copper wire; 5/16" core; variable slug tuned; overall dimensions: 13/16" diameter, 1 1/8" long; 1 1/2" leads; with slug out frequency of 38.5 megacycles, 95-105 micro-microfarads.	I-F trap inductors.	1	24A104679
L-604		COIL, TN-1 FILTER: same as L-603.	I-F trap inductors.		
N-601		DIAL, TUNER: same as N-401, except for calibration.	Dial scale reading in megacycles.		
O-601		ASSEMBLY, BACKING PLATE AND DIAL INDICATOR: same as O-401.	Dial indicator assembly.		
O-602		ASSEMBLY, SPINNER KNOB: same as O-405.	Tuner knob assembly.		
O-603		ASSEMBLY, SPINNER LOCK: same as O-406.	Handle shaft lock.		
O-604		BEARING, OILITE: same as O-408.	Gear bearing.		
O-605		BEARING, OILITE: same as O-409.	Gear mounting.		
O-606		CLAMP, TUBE RETAINER: stainless steel wire, .045" diameter; 1/4" diameter loops at each end, 1/8" diameter loop at center; 1 3/4" overall.	Fasten tube.	1	42A103723
O-607		COLLAR, DRIVE SHAFT: same as O-415.	Shaft retainer and spring tension adjustment.		
O-608		COUPLING, SLIDE: ceramic body, brass bushing, phosphor bronze studs; 4 setscrews 6-32 thread, 1/8" long; overall dimensions: 1" square, 1 1/16" high.	Shaft coupling.	1	58A48562
O-609		DISC, SPINNER KNOB: same as O-418.	Locking disc.		
O-610		GEAR, BACKLASH: same as O-421.	Part of tuning gear assembly.		
O-611		GEAR, BACKLASH: same as O-420.	Part of tuning gear assembly.		
O-612		GEAR, BACKLASH: same as O-419.	Part of tuning gear assembly.		
O-613		GEAR, BACKLASH: same as O-422.	Part of tuning gear assembly.		
O-614		GROMMET, RUBBER: neoprene, black, 1 1/32" outside diameter, 1/8" diameter, 3/16" thick, 1/16" groove along edge.	Tube retainer cushion.	18	37A104691

TABLE OF REPLACEABLE PARTS  
MODEL: Radio Receiving Equipment AN/APR-1 and AN/SPR-1

MAJOR UNIT: Tuning Unit TN-1/APR-1

Reference Symbol	Navy Stock No.	Name of Part and Description	Function	Mfr. and Desig. or AWS Type	Cont. or Gov't Drawg. or Spec. No.
O-615		HANDLE, KNOB: same as O-424.	Knob handle.		
O-616		HUB, DIAL: same as O-425.	Mount dial shaft assembly.		
O-617		INDICATOR, DIAL: same as O-457.	Dial indicator.		
O-618		KNOB, SPINNER: same as O-426.	Tuner knob.		
O-619		PINION, IDLER: same as O-432.	Part of tuning gear assembly.		
O-620		PINION, IDLER GEAR: stainless steel; overall dimensions: .7916" outside diameter, .538" thick; .436" diameter hole; 36 teeth on gear portion.	Part of tuning gear assembly.	1	44B103706
O-621		PINION, GEAR: same as O-431.	Part of tuning gear assembly.		
O-622		PINION, IDLER: same as O-434.	Part of tuning gear assembly.		
O-623		PLATE, BACKING: same as O-438.	Mount dial indicator.		
O-624		SHAFT, DIAL: stainless steel; overall dimensions: 1 7/8" long, 1 end 5/8" diameter, other end .374" diameter.	Mount dial.	1	47A103762
O-625		SHAFT, HAND WHEEL: same as O-441.	Mount tuning knob; part of tuning gear assembly.		
O-626		SPACER, BACKING PLATE: same as O-443.	Backing plate spacer.		
O-627		SPACER, BEARING AND DRIVE SHAFT: same as O-445.	Bearing spacer.		
O-628		SPACER, INDICATOR: same as O-446.	Indicator spacer.		
O-629		SPRING, COMPRESSION COIL: same as O-450.	Anti-backlash gear springs.		
O-630		SPRING, COMPRESSION COIL: same as O-451.	Anti-backlash gear springs.	1	41A103866
O-631		SPRING, TUBE RETAINER: stainless steel wire, .024" diameter, 22 turns close wound, 3/16" diameter, 1 3/16" long, loops at each end.	Tube retainer.	1	51X103962
O-632		ASSEMBLY, DIAL HUB AND GEARS: composed of backlash gear O-610, backlash gear O-611, dial hub O-616, and compression coil spring O-630.	Part of gear assembly.	1	51X103960
O-633		ASSEMBLY, IDLER PINION AND GEARS: composed of: backlash gear O-610, backlash gear O-613, idler pinion O-619, and compression spring coil O-630.	Part of gear assembly.	1	51X103961
O-634		ASSEMBLY, TUNER DRIVE PINION AND GEARS: composed of: backlash gear O-612, backlash O-613, idler pinion O-622, and compression coil spring O-630.	Part of gear assembly.	1	51X103961
P-601		PLUG, CHASSIS: same as P-401.	Antenna.		
P-602		PLUG, CHASSIS: same as P-401.	I.F. plug.		

**TABLE OF REPLACEABLE PARTS**  
**MODEL: Radio Receiving Equipment AN/APR-1 and AN/SPR-1**

TABLE OF REPLACEABLE PARTS			MAJOR UNIT: Tuning Unit TN-1 / APR-1		
Reference Symbol	Navy Stock No.	Name of Part and Description	Function	Mfr. and Desig. or AWS Type	Cont. or Gov't Dwg. or Spec. No.
R-601	R16-R-17310-7LG	RESISTOR: fixed, carbon; 10,000 ohms, $\pm 10\%$ , 1 watt, insulated, $\frac{3}{4}$ " long, .281" diameter; axial leads $1\frac{1}{2}$ " long.	Plate loading.	23	6B6430
R-602		RESISTOR: same as R-132.	Grid lead.	33	
R-603	R16-R-17285LG	RESISTOR: fixed, carbon; 5,000 ohms $\pm 10\%$ , $\frac{1}{2}$ watt, insulated; $\frac{1}{2}$ " long, .218" diameter; axial leads.	Cathode bias.	23	6B5634
R-604		RESISTOR: same as R-601.	B+ filter.	#CM $\frac{1}{2}$	
R-605		RESISTOR: same as R-406.	Trap load.	33	
R-606		RESISTOR: same as R-406.	Trap load.	#504	
R-607	R16-R-17473-SM	RESISTOR: fixed, carbon; 4.7 megohms, $\pm 10\%$ , $\frac{1}{2}$ watt, insulated; $\frac{3}{8}$ " long, .140" diameter; axial leads.	Grid bias, V-601.	4	6B6391
T-601		COIL, TUNING: $8\frac{1}{4}$ turns of .050" diameter solid copper wire, silver plated; $\frac{9}{32}$ " inside diameter; overall dimensions: $1\frac{13}{16}$ " long, $1\frac{3}{4}$ " wide, $1\frac{1}{16}$ " high.	Oscillator tuning.	1	24A103717
V-601		TUBE: type 9002.	Oscillator.		
V-602		TUBE: type 9002.	Mixer.		
X-601		RECEPTACLE, PLUG: same as X-401.	Filament receptacle.		
X-602		RECEPTACLE, PLUG: same as X-401.	B+ receptacle.		
X-603		RECEPTACLE, PLUG: same as X-401.	28 V. D-C power receptacle.		
X-604	R16-S-6183-17	SOCKET, TUBE: bakelite body, steel saddle type mounting plate; 7 phosphor bronze contacts, silver plated; .875" between 2-.093" diameter mounting holes; overall dimensions: $1\frac{3}{32}$ " long, $\frac{47}{64}$ " wide, $\frac{1}{2}$ " high.	Tube socket V-601 and V-602.	9	9B38418

TABLE OF REPLACEABLE PARTS

MODEL: Radio Receiving Equipment AN/APR-1 and AN/SPR-1

MAJOR UNIT: Tuning Unit TN-3B/APR-1

Reference Symbol	Navy Stock No.	Name of Part and Description	Function	Mfr. and Desig. or AWS Type	Cont. or Gov't Dwg. or Spec. No.
A-701	R16-GV-1X107580	ASSEMBLY, BRACKET AND BUMPER: bracket: stainless steel; overall dimensions: 1/2" wide, .062" thick, one leg: 15/32" long, .136" diameter hole; one leg: 17/32" long; one leg: 1 1/16" long, 1/32" x 5/32" hole; rubber bumper: neoprene or buna "S"; 1/2" diameter, 1/4" thick, 1/4" slot with cold rolled steel washer between .136" slot; rivet: 3/16" long, .122" diameter; brass, white nickel finish.	Adjust worm gear.	1	1X107580
A-702		ASSEMBLY, HUB AND GEAR RIVETED: hub hot rolled armo ingot iron (magnetic); white nickel; overall dimensions: 1 1/2" outside diameter, .250" inside diameter of shaft, .313" outside diameter of shaft, .066" thick, three .101" diameter holes 120 degrees apart; gear: natural bakelite; .312" inside diameter, three .101" diameter holes 120 degrees apart, .937" diameter from center; 3/32" thick; screw 3/16" long .088" diameter, brass white nickel finish.	Part of clutch assembly.	1	51X106947
A-703		ASSEMBLY, HOUSING AND LUG RIVETED: composed of clutch housing O-732 and soldering lug E-734.	Clutch housing.	1	51X106945
A-704		ASSEMBLY, MOTOR SHIELD AND BUMPER: silver plated copper: .028" .036" thick, 3 1/32" long, 1 29/64" wide, 1.41" high, 2 edges 5/16" wide; eight .140" diameter holes; rubber bumper, neoprene; 1/2" diameter, 1/4" thick; cold rolled washer in center, .136" diameter hole.	Motor hash shield.	1	1X107349
A-705		ASSEMBLY, POTENTIOMETER BRACKET AND BUSHINGS: bracket: aluminum; "U" shaped; overall dimensions: body: 1 7/8" high, 2" wide, 1 3/16" wide slot and 1/16" deep; one bend: 5/8" high, 2" wide with two .197" diameter and counterbore 5/16" diameter .040" deep, and one .140" diameter hole; .091" thick; bushing: threaded, stainless steel, .250" square, .250" thick, .152" hole, 6-32 thread.	Mount potentiometer R-708.	1	1X107350
A-706		ASSEMBLY SECTOR ADJUSTMENT COVER AND BRACKET: cover: aluminum (die-cast) alloy, black wrinkle; overall dimensions: 2 13/16" diameter, 9/16" thick; two 4-40 tap holes, one .127" diameter hole and spotface 5/16" diameter .010" deep; bracket: black nickel, "I" shaped, one leg 3/8" long with .136" diameter and counterbore 7/32" diameter 1/32" deep, other leg 15/32" long, 3/8" wide, .062" thick, rivet: .122" diameter, 5/32" long, brass, black nickel finish.	Adjustment cover.	1	1X107584
A-707		ASSEMBLY, SPINNER LOCK: same as O-406.	Handle shaft lock.		
A-708		ASSEMBLY, TOP COVER PLATE AND WINDOW: same as A-402.	Top plate.		
A-709		ASSEMBLY, TUNER PANEL STAKED: panel 7.531" long, 6.281" wide; aluminum #24 ST, .125" thick; pinion stud: stainless steel, overall dimensions: 1/2" diameter, 1" long, one end tapped 6-32 thread, 1/2" deep; idler gear stud: stainless steel, overall dimensions: 1/2" diameter, 29/32" long, one end tapped 6-32 thread; dial shaft bushing assembly: aluminum, 7/8" diameter, 1 1/32" high, .4365" diameter hole; bearing bushing: stainless steel, 7/8" diameter, 1 1/16" length, 1/4-32 tapped hole concentric with .752" diameter.	Parts mounting.	1	51X106875

TABLE OF REPLACEABLE PARTS

MODEL: Radio Receiving Equipment AN/APR-1 and AN/SPR-1

MAJOR UNIT: Tuning Unit TN-3B/APR-1

Reference Symbol	Navy Stock No.	Name of Part and Description	Function	Mfr. and Desig. or AWS Type	Cont. or Gov't Dwg. or Spec. No.
A-710		ASSEMBLY, TUNER UNIT HOUSING: same as A-405.	Parts mounting.		
A-711		BRACKET, CAM TRACK: same as A-407.	Mount cam track spring.		
A-712		BRACKET, DIAL INDICATOR: aluminum, "U" shaped; overall dimensions: 129/32" long, 13/16" wide, 19/32" high; one end has two .136" diameter holes; other end tapped with two 2-56 thread holes.	Mount dial indicator.	1	7A106695
A-713	R16-GV-7A106901	BRACKET, HOLD-DOWN: stainless steel; "L" shaped, overall dimensions: 1 1/4" long, 3/8" wide, .075" thick; two .180" diameter holes.	Fasten tuner in shock mount.	1	7A106901
A-714		BRACKET, I.F. COIL MOUNTING: same as A-430.	Mount I-F coil.		
A-715		BRACKET, MAIN DRIVE: aluminum, "Z" shaped; .091" thick; overall dimensions: 2.062" high, 31/32" wide; 2 holes .136" diameter on one leg, 2 holes .156" diameter in the other leg.	Main drive bracket.	1	7A106301
A-716		BRACKET, MOTOR DRIVE SWITCH: aluminum, "U" shaped, overall dimensions: 2 1/16" long, 1 1/8" wide, 1" high; one end has .484" diameter hole, two .136" diameter at other end.	Fasten switch S-702.	1	7A106319
A-717		BRACKET, PANEL COVER: aluminum, "L" shaped; 3/4" long, 3/4" wide, .091" thick; one 6-32 thread tapped hole on one leg, two .136" diameter holes on other leg.	Fasten panel cover.	1	7A106977
A-718		BRACKET, REVERSING SWITCH: aluminum, "L" shaped; overall dimensions: 1 3/4" long, 1" wide; one .484" diameter hole on one leg, two .136" diameter holes on the other leg.	Fasten reversing switch S-701.	1	7A106317
A-719		BRACKET, SPRING RETAINER: same as A-411.	Fasten rotor link anti-backlash spring.		
A-720		BRACKET, SPRING RETAINER: same as A-410.	Fasten pointer spring.		
A-721		BRACKET, WIPER SPRING: brass, white nickel finish, half-hard; "L" shaped; 7/8" wide; .080" thick; one leg, 1/2" long, two .156" diameter holes, other leg: 13/32" long, two 4-40 thread holes.	Mount wiper springs.	1	7A107134
A-722		BRACKET, WORM DRIVE ASSEMBLY MOUNTING: stainless steel, "L" shaped; overall dimensions: 1" long, 1 1/16" wide, .062" thick; four 1/64" x 5/64" holes, two in each leg.	Mount worm gear.	1	7A106627
A-723		BRACKET, WORM DRIVE SHAFT: stainless steel, "U" shaped; overall dimensions: 127/32" long, 5/8" wide, 13/16" high, .093" thick; .437" diameter hole in one leg, one 5/16-32 thread hole (flat side) and two 6-32 threaded holes.	Mount worm gear.	1	7A106303
A-724		CLAMP, CABLE: same as A-204.	Fasten cables.		
A-725		CLAMP, CABLE: same as A-414.	Cable clamp.		
A-726		COVER, TUNER ADJUSTING SCREW: same as A-416.	Compensator screw cover.		

TABLE OF REPLACEABLE PARTS  
MODEL: Radio Receiving Equipment AN/APR-1 and AN/SPR-1 MAJOR UNIT: Tuning Unit TN-3B/APR-1

Reference Symbol	Navy Stock No.	Name of Part and Description	Function	Mfr. and Desig. or AWS Type	Cont. or Gov't Dug. or Spec. No.
A-727		COVER, TUNER PANEL: aluminum, 3-5; 6.312" wide, 7.562" long, 1 <sup>25</sup> / <sub>64</sub> " thick, black wrinkle finish, white letters.	Cover.	1	15B102358
A-728		COVER, PLATE (BOTTOM): same as A-421.	Bottom cover.		
A-729		COVER, PLATE (TOP): same as A-420.	Top cover.		
A-730		PLATE, LOCKING: same as A-422.	Cam track screw retainer.		
A-731		PLATE, MAIN DRIVE: aluminum .125" thick, 41 <sup>5</sup> / <sub>32</sub> " long, 2" wide; one .624" diameter hole, one .640" diameter hole, four .144" diameter holes.	Fasten clutch assembly.	1	64A106556
A-732		PLATE, MOTOR MOUNTING: aluminum; overall dimensions: 51 <sup>9</sup> / <sub>32</sub> " long, 1 <sup>3</sup> / <sub>32</sub> " wide on one end, 1 <sup>27</sup> / <sub>32</sub> " on other end; .091" thick; 3 holes .437" in diameter; 3 holes .250" in diameter, 2 holes tapped 6-32 thread, 7 holes tapped 4-40 thread.	Mount motor, B-701.	1	64B106454
A-733		SLEEVE, RUBBER: same as A-423.	Cable protector		
A-734		SLEEVE, RUBBER: same as A-206.	Protect cables.		
A-735		SPACER, CAM TRACK: same as A-425.	Cam track spacer.		
A-736		SPACER, VARIABLE CAM TRACK: same as A-427.	Cam track spacer.		
A-737		STRIP, TERMINAL: same as A-113.	Tie-point.		
A-738		SUPPORT, MOTOR SHIELD: aluminum (die-cast); overall dimensions: base 11 <sup>11</sup> / <sub>16</sub> " long x 1.343" x 1.312", 1 <sup>1</sup> / <sub>16</sub> " thick; hole diameters: one .187", two .190", 1.94", two .120", and all are 5 <sup>1</sup> / <sub>16</sub> " diameter boss 1 <sup>1</sup> / <sub>32</sub> " high on outside of casting only; three .136" holes, one 4-32 tapped hole.	Mount motor shield.	53	7C107149
A-739		SUPPORT, VARIABLE CAM ADJUSTMENT SCREW: same as A-426.	Part of cam track assembly.		
A-740		WINDOW, TOP COVER: same as A-429.	Top cover window.		
A-741		ASSEMBLY, ALIGNMENT TOOL: same as H-301.	Alignment tool.		
B-701		MOTOR, PERMANENT MAGNET: 27.5 volts, D-C, 150 milliamperes; reversible; overall dimensions: 21 <sup>7</sup> / <sub>32</sub> " long, 13 <sup>3</sup> / <sub>32</sub> " diameter.	Drive gear assembly.	1	59B103881
C-701		CAPACITOR: same as C-412.	Grid coupling.		
C-702		CAPACITOR: same as C-401.	Meter by-pass for test purposes only.		
C-703	R16-C-9973-50	CAPACITOR: fixed, mica; 250 micro-microfarads ±10%; 350 volts D-C working; 19 <sup>3</sup> / <sub>32</sub> " long, 3 <sup>8</sup> / <sub>16</sub> " wide, 7 <sup>1</sup> / <sub>64</sub> " thick.	Parts of hash filter.	56	21A112247
C-704		CAPACITOR: same as C-703.	Part of hash filter.		
C-705		CAPACITOR: same as C-401.	B+ by-pass.		

TABLE OF REPLACEABLE PARTS  
MODEL: Radio Receiving Equipment AN/APR-1 and AN/SPR-1

MAJOR UNIT: Tuning Unit TN-3B/APR-1

Reference Symbol	Navy Stock No.	Name of Part and Description	Function	Mfr. and Desig. or AWS Type	Cont. or Gov't Drawg. or Spec. No.
C-706		CLIP, CRYSTAL: same as C-403.	Coupling.		
C-707		CAPACITOR: same as C-404.	Part of antenna filter.		
C-708		CAPACITOR: same as C-405.	Part of antenna filter.		
C-709		CAPACITOR: same as C-404.	Part of antenna filter.		
C-710		CAPACITOR: same as C-407.	Coupling.		
C-711		CAPACITOR: same as C-102.	I.F. by-pass.		
C-712		WASHER, CAPACITOR: same as C-409.	B+ by-pass.		
C-713		WASHER, CAPACITOR: same as C-409.	Filament by-pass.		
C-714		WASHER, CAPACITOR: same as C-409.	Hash filter.		
C-715		CAPACITOR: fixed, mica; 650 micro-microfarads $\pm 20\%$ ; 500 volts D-C working; brown mica case; color coded: blue, green, brown; .688" long, .438" wide, .188" thick; 1.312" axial leads.	Hash by-pass.	2 30 37	21R2700
C-716		CAPACITOR, LUG: brass, .032" thick, 1/8" wide, end 5/8" diameter; .144" diameter hole in center.	Hash by-pass.	1	29A112245
C-717		CAPACITOR: same as C-703.	Hash by-pass.		
E-701		ASSEMBLY, ANTENNA FILTER: same as E-401.	Suppress 200 megacycle carrier.		
E-702		ASSEMBLY, MOUNTING STRIP AND BUSHINGS: same as E-402.	Tie-point.		
E-703		BAR, GRID: same as E-403.	Mount tube V-701.		
E-704		BAR, PLATE: same as E-405.	Mount tube V-701.		
E-705		BRACKET, TUBE: same as E-404.	Mount tube V-701.		
E-706		CABLE, ANTENNA: same as E-406.	Antenna lead-in.		
E-707		CLAMP, CABLE: same as A-413.	Cable clamp.		
E-708	R16-GV-30K107313	CABLE, SHIELDED: white coded; 1 1/4" long, 1/2" bare wire at each end and 1 1/4" insulated wire at each end, 1/8" shield folded back and soldered at each end.	Connect fuse to 28 volt receptacle.	1	30K107313
E-709		CABLE, SHIELDED: orange coded; 7 3/4" long, 1/2" bare wire at each end and 1 1/2" insulated wire at one end and 1" at other end, 1/8" shield folded back and soldered at each end.	Connect motor to switch S-701.	1	30K107312
E-710		CABLE, SHIELDED: blue coded; 9 1/4" long, 1/2" bare wire at each end, 2 1/4" insulated wire at one end and 1" at other end, 1/8" shield folded back and soldered at each end.	Connect fuse F-701 to switch S-702.	1	30K107308

TABLE OF REPLACEABLE PARTS

MAJOR UNIT: Tuning Unit TN-3B / APR-1

MODEL: Radio Receiving Equipment AN / APR-1 and AN / SPR-1

Reference Symbol	Navy Stock No.	Name of Part and Description	Function	Mfr. and Desig. or AWS Type	Cont. or Gov't Dwg. or Spec. No.
E-711		CABLE, SHIELDED: black coded; 8" long, 1/2" bare wire at each end, 1 1/2" insulated wire at each end, 1/8" shield folded back and soldered at each end.	Connect switch S-701 to potentiometer R-708.	1	30K107311
E-712		CABLE, SHIELDED: yellow coded; 9 3/4" long, 1/2" bare wire at each end, 1 1/2" insulated at one end, and 1" at other end, 1/8" shield folded back and soldered at each end.	Connect magnetic clutch to switch S-702.	1	30K107309
E-713		CABLE, SHIELDED: green coded; 13" long, 1/2" bare wire at each end, 1 1/2" insulated wire at each end, 1/8" shield folded back and soldered at each end.	Connect motor B-701 to potentiometer R-708.	1	30K107310
E-714		CLIP, TUBE: same as E-407.	Mount tube, V-701.		
E-715		DIELECTRIC, CRYSTAL: same as E-408.	Dielectric for C-706.		
E-716		INSULATOR, CRYSTAL CLIP: same as E-411.	Insulation for capacitor C-706.		
E-717		INSULATOR, FEED THRU: same as E-433.	Antenna lead to tie point.		
E-718		INSULATOR, FEED THRU: phenolic; overall dimensions: 5/16" outside diameter, 3/16" body diameter, .120" hole diameter.	Feed thru.	1	14A107260
E-719		INSULATOR, FILTER CLIP: same as E-412.	Insulator tube bracket.		
E-720		INSULATOR, FILTER CLIP: same as E-413.	Insulator tube bracket.		
E-721		INSULATOR, GRID BAR: same as E-414.	Grid bar insulator.		
E-722		INSULATOR, GRID BAR: same as E-415.	Mount grid bar.		
E-723		INSULATOR, MICA: same as E-416.	Dielectric for capacitors C-712, C-713, C-714.		
E-724		INSULATOR, RECEPTACLE: same as E-417.	Insulator for capacitors C-712, C-713, C-714.		14A106323
E-725		INSULATOR, STAND OFF: same as E-419.	Antenna lead tie point.	1	
E-726		INSULATOR, SLIP RING: phenolic; .782" outside diameter, .655" inside diameter.	Part of clutch assembly.		
E-727		LUG, SOLDERING: phosphor bronze, .020" thick; hot tinned plated; lock-double-bent; 2 slot wire hole, 6L mounting hole.	Tie point.	22	29K5259
E-728		LUG, SOLDERING: brass, .018" thick; hot tinned plated; lockflat; two .080" wire hole; 4L mounting hole.	Tie point.	22	29K5361
E-729		LUG, SOLDERING: same as E-425.	Tie point.		
E-730		LUG, SOLDERING: same as E-103.	Tie point.		
E-731		LUG, SOLDERING: same as E-421.	Tie point.		



TABLE OF REPLACEABLE PARTS  
MODEL: Radio Receiving Equipment AN/APR-1 and AN/SPR-1

MODEL: Radio Receiving Equipment AN/APR-1 and AN/SPR-1		MAJOR UNIT: Tuning Unit TN-3B/APR-1			
Reference Symbol	Navy Stock No.	Name of Part and Description	Function	Mfr. and Desig. or AWS Type	Cont. or Gov't Dwg. or Spec. No.
E-732		LUG, SOLDERING: same as E-422.	Tie point.		
E-733		LUG, SOLDERING: same as E-424.	Tie point.		
E-734		LUG, SOLDERING: brass, .018" thick; Cinch solder plated; external-flat; one .062" wire hole; extruded mounting holes.	Tie point.	9 #2428	29K5384
E-735		SPACER, TUBE BRACKET: same as E-428.	Spacer.		
E-736		STRIP, TERMINAL: phenolic; 1 1/8" long, 3/8" wide, two .187" diameter holes, 2 lugs.	Tie point.	9	31A60837
E-737		STRIP, TERMINAL: same as E-430.	Tie point.		
E-738		LUG, SOLDERING: brass, .026" thick; hot tinned plated; plain bent; one .080" wire hole; #6 mounting hole.	Tie point.	22	29K5360
E-739		INSULATOR, CAPACITOR: Same as E-410.			
E-740		INSULATOR, CAPACITOR: Same as E-409.			
E-741		INSULATOR, CAPACITOR: Same as E-431.			
E-742		WIPER SPRING, ASSEMBLY: composed of tungsten contact on spring steel wiper arm, mounted on a phenolic block, overall dimensions: 2 3/16" long, 1" wide, 1 9/32" length.	Clutch contacts.	1	51B106948
F-701		FUSE: one ampere, 250 volts; 1 1/4" x 9/16" diameter.	Overload protection.	15	65X104705
H-701		GROMMET: rubber, black; 5/8" outside diameter ±.031; 1 3/32" thick; 3/32" groove along edge; 9/64" diameter hole.	Feed thru.	18	37A106403
H-702		GROMMET: rubber, black; 5/16" outside diameter ±.031 thick, 3/32" groove along edge; 7/64" diameter hole.	Feed thru.	18	37A106402
H-703		GROMMET: same as H-401.	Feed thru.		
H-705		HANDLE: same as H-402.	Tuner handle.		
H-706		LOCKWASHER: 5/16" internal; 19/32" outside diameter, .321" inside diameter, .030" thick; phosphor bronze, white nickel finish.	Part of worm gear assembly.	22 #1918	4S9762
H-707		LOCKWASHER: 5/8" internal; 7/8" outside diameter, .652" inside diameter, .022" thick; carbon steel, white nickel finish.	Fasten fuse receptacle.	22 #1228-2	4S9789
H-708		LOCKWASHER: #4 external; 9/32" outside diameter, .120" inside diameter, .018" thick; spring steel, white cadmium finish.	Fasten wiper bracket.	22 #1104	4S7667
H-709		LOCKWASHER: 1/4" external; 1/2" outside diameter, .261" inside diameter, .025" thick; spring steel, white cadmium finish.	Fasten main drive bushing.	22 #1114	4S7678
H-710		LOCKWASHER: same as H-410.	General.		

TABLE OF REPLACEABLE PARTS  
MODEL: Radio Receiving Equipment AN/APR-1 and AN/SPR-1 MAJOR UNIT: Tuning Unit TN-3B/APR-1

Reference Symbol	Navy Stock No.	Name of Part and Description	Function	Mfr. and Desig. or AWS Type	Cont. or Gov't Drawg. or Spec. No.
H-711		LOCK WASHER: same as H-315.	General.		
H-712		LOCK WASHER: same as H-408.	General.		
H-713		LOCK WASHER: same as H-403.	General.		
H-714		LOCK WASHER: same as H-411.	Cover assembly.		
H-715		LOCK WASHER: same as H-412.	Fasten tube bracket.		
H-716		LOCK WASHER: same as H-314.	Fasten adjustment cover.		
H-717		LOCK WASHER: same as H-404.	General.		
H-718		LOCK WASHER: same as H-407.	General.		
H-719		LOCK WASHER: same as H-405.	Fasten plugs P-701 and P-702.		
H-720		LOCK WASHER: same as H-409.	Fasten lug on grid bar; backing plate on panel.		
H-721		LOCK WASHER: same as H-406.	General.		
H-722		LOCK WASHER: same as H-482.	Fasten capacitors C-712, C-713, C-714.		
H-723		LOCK WASHER: $\frac{3}{8}$ " internal; $\frac{1}{2}$ " outside diameter, .383" inside diameter, .022" thick; carbon steel, white nickel finish.	Fasten potentiometer R-708.	22 #1220-2	4S9790
H-724		NUT, CAP: same as H-423.	Antenna feed thru.		
H-725		NUT: same as H-102.	General.		
H-726		NUT: $\frac{5}{16}$ -32 thread, $\frac{7}{16}$ " diameter, $\frac{3}{32}$ " thick; hexagonal; brass, white nickel finish.	Fasten worm gear.	1	2S8357
H-727		NUT: same as H-422.	General.		
H-728		NUT: $\frac{15}{32}$ -32 thread, $\frac{9}{16}$ " diameter, $\frac{1}{16}$ " thick; hexagonal, steel, white nickel finish.	Fasten switch, S-701.	52	2S9636
H-729		NUT: same as H-317.	General.		
H-730		NUT: same as H-208.	Fasten hold-down bracket.		
H-731		NUT: $\frac{1}{4}$ -32 thread, $\frac{3}{8}$ " diameter, $\frac{3}{32}$ " thick; hexagonal, brass, white nickel finish.	Fasten main drive bushing.	26	2S8365
H-732	R16-GV-2A106667	NUT, LOCK (DIAL POINTER): stainless steel; overall dimensions $\frac{9}{32}$ " long, $\frac{3}{8}$ " wide; $\frac{1}{16}$ " slot $\frac{3}{32}$ " deep; 6-32 thread.	Lock pointers in position.	1	2A106667
H-733		NUT: same as H-417.	Fasten tube clip.		

TABLE OF REPLACEABLE PARTS

MODEL: Radio Receiving Equipment AN/APR-1 and AN/SPR-1

MAJOR UNIT: Tuning Unit TN-3B/APR-1

Reference Symbol	Navy Stock No.	Name of Part and Description	Function	Mfr. and Desig. or AWS Type	Cont. or Gov't Dwg. or Spec. No.
H-734		NUT: 15/32-32 thread, hexagonal; 3/32" thick; brass, black nickel finish.	Fasten switch S-702.	26	2S9641
H-735		NUT: 3/8-32 thread, 1/2" diameter; hexagonal; 3/32" thick; brass, white nickel finish.	Fasten potentiometer R-708.	26	2S8364
H-736		NUT: same as H-420.	Fasten capacitors C-712, C-713, C-714.		
H-737		RIVET: .088" diameter, 5/32" long; brass, black nickel finish.	General.	24	5S1685
H-740		RIVET, CAM ROLLER LINK: same as H-428.	Fasten helical gear to link.		
H-741		RIVET, SHOULDER: same as H-429.	Fasten compensator screw cover.		
H-742		SCREW: 8-32 thread, 3/8" long, slotted binderhead, brass, white nickel finish.	Fasten hold-down bracket.	26	3S1292
H-743		SCREW: 4-40 thread, 3/8" long; slotted binder head; brass, black nickel finish.	Fasten handle stud.	26	3S1874.
H-744		SCREW: 6-32 thread, 1/2" long, slotted binder head; brass, white nickel finish.	General.	26	3S6921
H-745		SCREW: same as H-334.	Fasten worm gear bracket.		
H-746		SCREW: same as H-435.	Fasten lug to housing..		
H-747		SCREW: 4-40 thread, 9/16" long; slotted flat head; brass, white nickel finish.	Fasten terminal strip.	26	3S1859
H-748		SCREW: 6-32 thread, 3/16" long, slotted binder head; brass, white nickel finish.	General.	26	3S8030
H-749		SETScrew: same as H-463.	Fasten idler pinion gear.		
H-750		SCREW: same as H-104.	Mount coil spacers.		
H-751		SCREW: same as H-438.	Fasten tube bracket.		
H-752		SCREW: same as H-440.	General.		
H-753		SCREW: same as H-441.	Fasten tube clip.		
H-754		SCREW: 4-40 thread, 1/4" long, slotted binder head; brass, white nickel finish.	General.		
H-755		SCREW: same as H-456.	Fasten cam track assembly.		
H-756		SCREW: same as H-457.	Fasten cam track assembly.		

TABLE OF REPLACEABLE PARTS  
MODEL: Radio Receiving Equipment AN/APR-1 and AN/SPR-1

MAJOR UNIT: Tuning Unit TN-3B/APR-1

Reference Symbol	Navy Stock No.	Name of Part and Description	Function	Mfr. and Desig. or AWS Type	Cont. or Gov't Dwg. or Spec. No.
H-757		SCREW: same as H-465.	Cam track compensator.		
H-758		SCREW: same as H-444.	Fasten handle cover to housing.		
H-759		SCREW: same as H-430.	General.		
H-760		SCREW: 4-40 thread, 3/8" long; slotted binder head; brass, white nickel finish.	General.	26	3S1299
H-761		SCREW: same as H-211.	General.		
H-763		SCREW: same as H-446.	Fasten antenna.		
H-764		SCREW: same as H-436.	Fasten top and bottom cover.		
H-766		SCREW: same as H-452.	Mount filter assembly.		
H-767		SCREW: same as H-461.	Fasten strip E-702.		
H-768		SCREW: same as H-462.	Fasten adjustment cover.		
H-769		SCREW: 6-32 thread, 3/8" long; slotted binder head; brass, black nickel finish.	Fasten cover.	26	3S9677
H-770		SCREW: 6-32 thread, 3/16" long; slotted binder head; brass, black nickel finish.	Fasten cover.	26	3S1552
H-771		SCREW: 6-32 thread, 7/8" long; slotted binder head; brass, white nickel plated.	Fasten stand-off insulator.	26	3S1838
H-772		SCREW: same as H-447.	Mount butterflies.		
H-773		SCREW: same as H-450.	Fasten backing plate.		
H-774		SCREW: 4-40 thread, 7/16" long; slotted binder head; brass, white nickel finish.	Fasten insulator feed thru.	26	3S1534
H-775		SCREW: same as H-445.	Fasten helical gear.		
H-776		SCREW: same as H-434.	General.		
H-777		SCREW: same as H-458.	Fasten capacitor, C-705.		
H-778		SCREW: 6-32 thread, 7/8" long; slotted flat head; brass, white nickel finish.	Fasten motor assembly.	26	3S1538
H-779		SCREW: same as H-439.	Fasten plug.		
H-780		SET SCREW: same as H-464.	Fasten knob.		
H-781		SET SCREW: same as H-453.	General.		
H-782		SET SCREW: same as H-463.	Fasten dial lock collar.		

TABLE OF REPLACEABLE PARTS  
MODEL: Radio Receiving Equipment AN/APR-1 and AN/SPR-1 MAJOR UNIT: Tuning Unit TN-3B/APR-1

Reference Symbol	Navy Stock No.	Name of Part and Description	Function	Mfr. and Desig. or AWS Type	Cont. or Gov't Draw. or Spec. No.
H-784		STUD, COVER: cold rolled steel; overall dimensions: 2 5/8" long, 5/16" diameter; one section 2.218" long, 6-32 tapped 1/2" full thread; other section 6-32 tapped 1/32" full thread.	Mount panel cover.	1	46K106938
H-785		STUD, HANDLE SPACING: brass, white nickel; overall dimensions 1 9/16" length, 5/16" diameter; tap 8-32 thread x 3/8" deep, counterbore .193" diameter x 1/8" deep; 8-32 thread.	Handle spacer.	1	46A106697
H-786		STUD, MAIN DRIVE PLATE: aluminum; overall dimensions: 2.062" long, 5/16" diameter; 6-32 tapped; 3/8" deep on both ends.	Mount main drive plate.	1	46A106538
H-787		STUD, MOTOR MOUNTING: stainless steel; overall dimensions: 3/8" long, slot 3/64" wide x 3/64" deep; 1 5/32" diameter, 4-48 thread 1/8" long on one end.	Mount motor, B-701.	1	3A107168
H-788		STUD, PIVOT, same as H-466.	Mount capacitor operating cam.		
H-789		STUD, ROTOR LINK: same as H-467.	Fasten cam link to lever and cam.		
H-790		STUD, SPINNER KNOB: same as H-468.	Fasten knob handle.		
H-791		WASHER: same as H-474.	General.		
H-792		WASHER: 5/8" outside diameter .140" inside diameter, .0319" thick, brass, white nickel finish.	Mount motor assembly.		
H-793		WASHER: same as H-470.	Roller washer.		
H-794		WASHER: 3/16" outside diameter, .101" inside diameter, .0159" thick, brass, hot tin finish.	Mount dial window.	41	4S8223
H-795		WASHER: same as H-471.	Mount capacitor C-705.		
H-797		WASHER: 1/4" outside diameter, .144" inside diameter, .0641" thick; brass, white nickel finish.	Fasten solder lugs.	35	4S1705
H-798		WASHER: same as H-475.	General.		
H-799		WASHER: phenolic; 7/8" overall diameter, .666" inside diameter, .017" thick; one .062" diameter hole on one end, .128" diameter on other end.	Part of clutch assembly.	1	4A106548
H-800		WASHER, DIAL SHAFT: same as H-480.	Dial shaft washer.		
H-801		WASHER, FIBRE: same as H-301.	Mount stand-off insulator.		
H-802	R17-W-367	WASHER, FUSE SPACER: black fiber; 13/16" outside diameter, .640" inside diameter, 1/16" thick.	Mount fuse receptacle.	1	4A106663
H-803		WASHER, HANDLE: same as H-476.	Fasten handle.		
H-804		WASHER, INSULATING: same as H-469.	Fasten resistor R-705.		

TABLE OF REPLACEABLE PARTS  
MODEL: Radio Receiving Equipment AN/APR-1 and AN/SPR-1 MAJOR UNIT: Tuning Unit TN-3B/APR-1

Reference Symbol	Navy Stock No.	Name of Part and Description	Function	Mfr. and Desig. or AWS Type	Cont. or Gov't Draw. or Spec. No.
H-805		WASHER, INSULATOR: bakelite; overall dimensions: 5/16" outside diameter, .120" inside diameter, .062" thick.	Mount insulator.	1	4A107273
H-806		WASHER, LOCATING: steel, white nickel finish .034" thick; 23/32" outside diameter, 19/32" inside diameter.	Mount switch S-701.	52	4K41955
H-807		WASHER, SPRING: same as H-479.	Fasten handle.		
H-808		WASHER, SPRING: phosphor bronze (.016-.018); 3/4" outside diameter; .261" inside diameter.	Part of clutch gear assembly.	1	4A106676
H-809		WASHER, WORM SHAFT: felt; overall dimensions: 9/32" inside diameter, 1/2" outside diameter, 1/16" thick.	Mount worm gear.	1	4A107272
H-810		SCREW: 4-40 thread, 3/16" long slotted binder head; brass, white nickel finish.	Fasten motor shield.	26	3S1238
H-811		SETScrew:			3S9709
H-812		WRENCH, ALLEN: same as H-345.	For 6-32 screws.		
H-813		WRENCH, ALLEN: same as H-346.	For 8-32 screws.		
J-701		RECEPTACLE, FUSE (COMPLETE): same as E-312.	Fuse holder.		
L-701		COIL, R.F. CHOKE (FIL): same as L-401.	Filament choke.		
L-702		COIL, R.F. CHOKE (FIL): same as L-401.	Filament choke.		
L-703		COIL, MAGNETIC CLUTCH: lucite spool; 15/16" diameter, .580" diameter, .625" body diameter; start knob .125" diameter, .062" thick; 1725 ft. #37 enameled copper wire, 100 ohms, lead length 1 1/4"	Connect motor drive to manual gears.	1	24A106946
L-704	R16-GV-24A107091	CHOKE, MOTOR FILTER: coil form: phenolic, 1" long, 1/4" diameter, 4-40 thread hole 5/16" deep on end; coil construction: 70, 50, 25 and 15 turns of single celianese wire, .095-.115 millihenries at 1000 cycles.	Hash filter.	1	24A107091
L-705		CHOKE, MOTOR FILTER: same as L-704.	Hash filter.		
L-706		COIL, I.F. (6 1/2 TURNS): same as L-407.	I-F coil.		
L-707		COIL, TN3 FILTER: same as L-405.	Part of antenna filter.		
L-708		COIL COUPLING: same as L-404.	Antenna filter coupling.		
L-709		COIL, TN-3, FILTER: same as L-405.	Part of antenna filter.		
L-710		COIL COUPLING (2 1/2 TURNS): same as L-406.	Part of antenna filter.		
L-711		CHOKE, FILAMENT: 40 turns #30 D.S.E. wire; 58 tooth cam gear; 63 tooth spindle gear; inductance = 25 microhenries, ±10% at 1000 C.P.S.	Hash by-pass.	1	24A41698

TABLE OF REPLACEABLE PARTS  
MODEL: Radio Receiving Equipment AN/APR-1 and AN/SPR-1

Reference Symbol	Navy Stock No.	Name of art and Description	Function	Mfr. and Desig. or AWS Type	Cont. or Gov't Dwg. or Spec. No.
LC-701		ASSEMBLY, OSCILLATOR BUTTERFLY: same as LC-401.	Oscillator tank circuit.		
LC-702		ASSEMBLY, ANTENNA BUTTERFLY: same as LC-402.	Antenna tank circuit.	1	34A106657
N-701		DIAL TUNER (CALIBRATION): aluminum, black, overall dimensions: 47/32" diameter, .066" thick; .877" inside diameter; three .136" diameter holes 120° apart at 1.125" diameter.	Dial scale readings in megacycles.		
O-701		ASSEMBLY, BACKING PLATE AND DIAL: same as O-401.	Dial indicator assembly.		
O-702		ASSEMBLY, CAM, LINK AND LEVER: same as O-402.	Vary antenna oscillator.		
O-703		ASSEMBLY, SPINNER KNOB: same as O-405.	Tuner knob assembly.		
O-704		BALL BEARING: stainless steel; .062 ± .0002" diameter.	Part of worm gear.	1	43A106796
O-705		BALL BEARING: stainless steel; .062" ± .0002" diameter.	Part of worm gear.	1	43K106797
O-706		BALL BEARING, SINGLE SEAL: same as O-509.	Drive shaft bearing.		
O-707		BALL BEARING: stainless steel, .125" ± .0002"; precision grade.	Part of clutch gear.		
O-708		BEARING, OILITE: same as O-409.	Gear mounting.	54	43K106371
O-709		BEARING, OILITE: same as O-408.	Gear bearing.		
O-710		BEARING, OPERATING CAM: same as O-410.	Capacitor operating cam bearing.		
O-711		BUSHING, MAIN DRIVE: bearing adjustment, stainless steel, 7/16" long, 1/4-32 thread; .046" slot 1/16" deep, tapered at 60°; 7/64" inside diameter.	Mount main drive plate.	1	43A106536
O-712		BUSHING, OPERATING CAM: same as O-411.	Mount operating cam.		
O-713		BUSHING, THREADED: same as A-314.	Mount cover.		
O-714		BUSHING, WORM SHAFT ADJ.: stainless steel; overall dimensions: 7/16" long, .046" slot, 1/16" deep on one end, .187" diameter on other end; 5/16-32 thread.	Part of worm gear assembly.	1	43A106299
O-715		CAM, CAPACITOR OPERATING: same as O-413.	Vary antenna oscillator.		
O-716		CAM, SWITCH ACTUATING (LOWER): stainless steel; overall dimensions: 19/16" length, 3/4" to 1/2" width, .043" thick, .474" diameter of hole, .125" diameter of slot; actuating end bent to 45° angle.	Actuate reversing switch S701.	1	45A106671
O-717		CLAMP, LOCKING (POINTER): stainless steel; overall dimensions: 7/16" long, 1/2" width, 1/4" thick; 6-32 thread.	Lock pointers in position.	1	42A106631
O-718		COLLAR, DIAL LOCK: stainless steel collar, 5/8" diameter, .187" thick; .251" square hole; two 6-32 tapped holes; .377" diameter bracket hole, 5/8" outside diameter, 1/2" leg length, .062" thick.	Dial lock collar.	1	45A107277

TABLE OF REPLACEABLE PARTS  
MAJOR UNIT: Tuning Unit TN-3B / APR-1  
MODEL: Radio Receiving Equipment AN / APR-1 and AN / SPR-1

Reference Symbol	Navy Stock No.	Name of Part and Description	Function	Mfr. and Desig. or AWS Type	Cont. or Gov't Dwg. or Spec. No.
O-719		COLLAR, MAIN DRIVE: aluminum; 5/8" diameter, 7/32" thick; .253" inside diameter; two 8-32 threaded holes.	Part of clutch assembly.	1	43A106321
O-720		COUPLING, FLEXIBLE: 3/4" long, 9/32" diameter; .078" hole through center; Lycar, black finish.	Motor shaft coupling.	1	37A107090
O-721		CAM, SWITCH ACTUATING (UPPER): stainless steel; overall dimensions: 1 21/32" long, .043" thick, 1 5/16" to 1/2" outside diameter, .693" hole diameter; .125" diameter of slot; actuating end bent to 45° angle.	Actuate reversing switch S-701.	1	45A106673
O-722		DISC, SPINNER KNOB: same as O-418.	Locking disc.	1	44K106801
O-723		GEAR, BACKLASH: stainless steel; .0327" thick; 96 teeth; 2 slots for anti-backlash spring; 2.0416" outside diameter; .500" diameter hole in center.	Tuning gear assembly.	1	44K106798
O-724		GEAR, BACKLASH: stainless steel; .0327" thick; 96 teeth; 2 slots for anti-backlash spring; 2.0416" outside diameter; .621" diameter hole in center.	Tuning gear assembly.	1	
O-725		GEAR, HELICAL: same as O-423.	Vary oscillator butterfly.		
O-726		GEAR, BACKLASH: same as O-421.	Tuning gear on dial shaft.		
O-727		GEAR, BACKLASH: same as O-420.	Tuning gear on dial shaft.		
O-728		SPRING, COMPRESSION: same as O-451.	Anti-backlash gear spring.		
O-729		HANDLE, KNOB: same as O-424.	Knob handle.		
O-730		HELICAL GEAR AND LINK: same as O-403.	Oscillator butterfly.	1	55B107007
O-731		HINGE COVER ADJUSTMENT: brass, black nickel; .092" x 1 13/32" stainless steel pin; overall dimensions 1" high, 3/8" from center of pin to both sides; two .101" diameter holes; two .136" diameter holes.	Cover hinge.	1	15A106315
O-732		HOUSING CLUTCH: hot rolled armco iron (magnetic); 1.500" diameter; one hole .128" diameter and counterbore 7/32" diameter; .020" deep and one hole .136" diameter.	Clutch housing.	1	43A106669
O-733		HUB DIAL: stainless steel; overall dimensions: 1.625" outside diameter; .688" hole diameter, .250" thick; three 4-40 tap holes 120° apart; 1.125" diameter; one .127" hole diameter.	Mount dial.	1	43A106463
O-734		HUB, DIAL GEAR: stainless steel; outside diameter 3/4", .336" thick; 2 holes tapped 8-32 thread.	Gear hub.	1	
O-735		INDICATOR, DIAL: same as O-457.	Dial indicator.		
O-736		KNOB, SPINNER: same as O-426.	Tuner knob.		
O-737		LEVER, ANTENNA ROTOR: same as O-427.	Mounts on antenna rotor cam.		



TABLE OF REPLACEABLE PARTS

MODEL: Radio Receiving Equipment AN/APR-1 and AN/SPR-1

MAJOR UNIT: Tuning Unit TN-3B/APR-1

Reference Symbol	Navy Stock No.	Name of Part and Description	Function	Mfr. and Desig. or AWS Type	Cont. or Gov't Dug. or Spec. No.
O-738		LINK, ANTENNA ROTOR CAM: same as O-428.	Connect antenna lever to capacitor cam.		
O-739		PINION DRIVER: stainless steel, .311" inside diameter; 3/16" thick.	Part of clutch gear assembly.	1	44B106286
O-740		PINION, IDLER: same as O-432.	Part of tuning gear assembly.		
O-741		PINION, IDLER (DRIVE GEAR): same as O-433.	Tuning gear assembly.		
O-742		PINION, IDLER (TUNER DRIVE): same as O-434.	Part of tuning gear assembly.		
O-743		PLATE, BACKING: same as O-438.	Mount dial indicator.		
O-744		POINTER, DIAL (LOWER): stainless steel; overall dimensions: 1 1/16" long, .065" thick, 7/8" outside diameter, .630" inside diameter, .125" slot; also one .140" diameter hole.	Sector adjust.	1	52A106678
O-745		POINTER, DIAL (UPPER): stainless steel; overall dimensions: 1 1/16" long, .065" thick, 7/8" outside diameter, .441" inside diameter, .125" slot, one .140" diameter hole.	Sector adjust.	1	52A106665
O-746		POINTER, ADJUSTMENT: same as O-435.	Cam screw adjustment pointer.		
O-747		RACE, BALL BEARING: stainless steel, passivate; 1 1/16" outside diameter, .625" diameter of body; .434" inside diameter tapered to .546" at 60°.	Part of clutch assembly.	1	43A106543
O-748		RACE, BALL (WORM DRIVE): stainless steel; body: .438" diameter, .130" diameter hole, 9/64" thick; collar 1/2" diameter, 1/32" thick, .250" hole tapered at 60°; overall dimensions: 1/2" outside diameter, .128" thick.	Part of worm gear assembly.	1	43A106297
O-749		RING, SLIP: stainless steel; .780" diameter, 1/64" thick; lug 1/8" wide, .014" thick.	Part of clutch assembly.	1	42A106639
O-750		ROLLER CAM: same as O-439.	Mount roller cams and pointer.		
O-751		ROLLER, CAM: same as O-436.	Antenna cam roller.		
O-752		ROLLER, VARIABLE CAM: same as O-437.	Cam track roller.		
O-753		SHAFT, DIAL: stainless steel; 3 1/16" length; one end 5/8" diameter, other end .311" diameter.	Part of tuning gear assembly.	1	47A106309
O-754		SHAFT, MAIN DRIVE: stainless steel; overall dimensions: 2 31/32" long, .658" diameter over knurl on ball race, 3/16" thick.	Part of clutch.	1	47B106325
O-755		SHAFT, WORM DRIVE: stainless steel; worm: 7/16" long, .250" diameter, right hand single thread worm; .125" diameter shaft.	Drive clutch.	1	47B106510
O-756		SHIM, TUBE BRACKET: brass, nickel plated; overall dimensions 27/32" long, 3/8" wide, .040" thick; two .187" diameter holes.	Tube bracket shim.	1	46A103984

TABLE OF REPLACEABLE PARTS

MODEL: Radio Receiving Equipment AN/APR-1 and AN/SPR-1 MAJOR UNIT: Tuning Unit TN-3B/APR-1

Reference Symbol	Navy Stock No.	Name of Part and Description	Function	Mfr. and Desig. or AWS Type	Cont. or Gov't Dug. or Spec. No.
O-757		SLEEVE, DIAL SHAFT (INNER): stainless steel, overall dimensions 1.354" long, .539" diameter; .499" body diameter; .127" diameter hole on both ends.	Dial shaft sleeve.	1	43A106333
O-758		SLEEVE, DIAL SHAFT (OUTER): stainless steel; overall dimensions: 1 13/16" diameter, .687" body diameter; .128" diameter hole on both ends.	Dial shaft sleeve.	1	43A106661
O-759		SLEEVE, NEOPRENE: 3/16" outside diameter, 1/8" inside diameter; 5/8" long, black.	Shock mounting.	6	37K61348
O-760		SPACER, BACKING PLATE: same as O-443.	Backing plate spacer.		
O-761		SPACER, INDICATOR: same as O-446.	Indicator spacer.		
O-763		SPRING, ANTI-BACKLASH: same as O-447.	Helical gear anti-backlash spring.		
O-764		SPRING, CAM ROLLER TRACK: same as O-448.	Cam track roller spring.		
O-765		SPRING, CAM TRACK: same as O-449.	Cam track roller spring.		
O-766		SPRING, COIL RETAINING: phosphorous bronze, .015" thick, 1 13/32" outside diameter, .515" inside diameter; 4 notches at 45° angles.	Magnetic coil spring.	1	41A106546
O-767		SPRING, COMPRESSION COIL: same as O-450.	Anti-backlash gear springs.		
O-769		SPRING, HINGE: beryllium copper or stainless steel, white nickel finish; 3/4" long, 1" wide, .020" thick; two .101" diameter holes.	Adjustment cover.	1	41A107034
O-770		SPRING, OPERATING CAM: same as O-452	Operating cam spring.		
O-771		SPRING, POINTER ADJUSTMENT: same as O-453.	Pointer adjustment spring.		
O-772		SPRING, SECTOR COVER SNAP: beryllium copper or stainless steel, black nickel; overall dimensions 1 1/8" long, 21/32" wide, two .010 holes .025" slot; four .101" diameter holes.	Lock adjustment cover.	1	41B107563
O-773		SPRING, WIPER: phosphor bronze, white nickel finish; overall dimensions: 2 5/64" long, .014" thick; two .189" holes, one .066" hole; one .078" hole.	Clutch contacts.	1	41A106593
O-774		SPRING, WIPER: phosphor bronze, white nickel finish; overall dimensions: 1 1/16" long, .014" thick, two .189" holes.	Clutch contact.	1	41A106637
O-775		WINDOW, DIAL: acetate; overall length: 3 3/16" long, 1 5/8" wide, .062" thick; four .106" holes.	Dial window.	39	61A106675
O-776		ASSEMBLY, DRIVER PINION AND GEARS: composed of gear O-723, gear O-724, spring O-728, and pinion O-741.	Part of tuning gear assembly.	1	51X106880
O-777		ASSEMBLY, GEAR SPRING AND HUB: composed of gear O-726, gear O-727, spring O-728, and hub O-734.	Part of tuning gear assembly.	1	51X106879

TABLE OF REPLACEABLE PARTS  
MODEL: Radio Receiving Equipment AN/APR-1 and AN/SFR-1  
MAJOR UNIT: Tuning Unit TN-3B/APR-1

Reference Symbol	Navy Stock No.	Name of Part and Description	Function	Mfr. and Desig. or AWS Type	Cont. or Gov't Draw. or Spec. No.
O-778		ASSEMBLY, PINION AND GEARS (INTER): composed of oilite bearing O-709, gear O-723, gear O-724, spring O-728 and pinion O-740	Tuning gear assembly.	1	51X106876
O-779		ASSEMBLY, PINION AND GEARS (IDLER): composed of bearing O-708, pinion O-742, gear O-723, gear O-724, and spring O-728.	Part of tuning gear assembly.	1	51X106877
O-780		CLUTCH, Assembly: 2.187" diameter x 3.000 long; Frank D. Palmer Co. Galvin special; consists of: Quantity Description Galvin No. 4 Setscrews #8-32 3S7110 2 Collar, main drive 43A106321 1 Coil, magnetic clutch 24A106946 1 Washer, slip ring insulator 4A106548 1 Shaft, main drive 47B106325 1 Insulator, slip ring 14A106323 1 Ring, slip (clutch) 42A106639 1 Lug, soldering (cinch #2428) 41A106456 3 Spring, coil retaining 29K5308 1 Rivet, 3/16" .088" 5S6843 1 Gear, main drive 44B106549 1 Hub, gear (main drive) 43A106313 1 Housing, clutch 15A106315	Motor gear clutch.	1	51C106634
O-781		KNOB, ROUND: bakelite; knurled edge 1" diameter, 9/16" thick; brass bushing .251" inside diameter, 15/32" high; 2 holes tapped 8-32 thread on side for setscrews.	Speed control.	1	36A102411
O-782		WORM DRIVE SHAFT, ASSEMBLY: composed of: Quantity Description Galvin No. 1 Washer 4K107651 1 Washer 4A107272 1 Washer 4S7674 1 Nut 2S8391 1 Ball bearing 43K106797 14 Ball bearings 43A106796 1 Bushing 43A106299 1 Race 43A106297 1 Bracket 7A106303 1 Shaft 47B106510 overall dimensions: 2 11/16" long, 1 3/32" high, 5/8" wide.	Drive gears.	1	51B106512
P-701		PLUG, CHASSIS (COMPLETE): same as P-401.	Antenna.		
P-702		PLUG, CHASSIS: same as P-401.	I-F plug.		
R-701		RESISTOR: same as R-402.	Grid leak.		
R-702	R16-R-17281-179LG	RESISTOR: fixed, carbon; 4,700 ohms $\pm 20\%$ ; 1 watt, insulated; .750" long, .142" diameter; axial leads, .142" long.	Parasitic suppression.	33 "518" 23 "CM"	6B5632
R-703		RESISTOR: same as R-403.	Plate dropping.		

TABLE OF REPLACEABLE PARTS  
MODEL: Radio Receiving Equipment AN/APR-1 and AN/SPR-1

MAJOR UNIT: Tuning Unit TN-3B/APR-1

Reference Symbol	Navy Stock No.	Name of Part and Description	Function	Mfr. and Desig. or AWS Type	Cont. or Gov't Drug. or Spec. No.
R-704		ASSEMBLY, I-F RESISTOR: same as R-404.	Parasitic suppressor.		
R-705		RESISTOR: same as R-405.	Filament.		
R-706		RESISTOR: same as R-101.	D-C by-pass to ground.		
R-707		RESISTOR: same as R-406.	I-F load.		
R-708	R16-P-6882-85	POTENTIOMETER: overall resistance 100 ohms $\pm 5\%$ ; 25 watts; $\frac{3}{8}$ -.32 thread bushing, overall dimensions: $2\frac{3}{32}$ " long, $2\frac{1}{32}$ " diameter including lugs.	Regulate motor speed.	12	18B103880
S-701	R17-S-28225	SWITCH, TOGGLE: double pole, double throw; $1\frac{5}{32}$ -.32 thread class 2 fit mounting stud; overall dimensions: $1\frac{13}{32}$ " long, $1\frac{1}{16}$ " wide, $1\frac{1}{8}$ " high.	Motor reversing switch.	52	40A106911
S-702	R17-S-28255-45	SWITCH, TOGGLE: single pole, single throw; $1\frac{5}{32}$ -.32 thread class 2 fit mounting stud; overall dimensions: $1\frac{15}{32}$ " long, $\frac{1}{2}$ " wide, $1\frac{1}{8}$ " high. or: SWITCH, TOGGLE: same as S-301.	Auto-manual switch.	22	40A106914
V-701		TUBE, RADIO: same as V-401.	Oscillator.		
X-701		RECEPTACLE, PLUG: same as X-401.	B+ receptacle.		
X-702		RECEPTACLE, PLUG: same as X-401.	Filament receptacle.		
X-703		RECEPTACLE, PLUG: same as X-401.	28 V. D-C power receptacle.		
Y-701		CRYSTAL, DETECTOR: same as Y-401.	Mixer and detector.		

TABLE OF REPLACEABLE PARTS  
MODEL: Radio Receiving Equipment AN/APR-1 and AN/SPR-1

Reference Symbol	Navy Stock No.	Name of Part and Description	Function	Mfr. and Desig. or AWS Type	Cont. or Gov't Dwg. or Spec. No.
A-901		ASSEMBLY, BRACKET AND BUMPER: same as A-701.	Adjust worm gear.		
A-902		ASSEMBLY, HOUSING AND LUG: same as A-703.	Clutch housing.		
A-903		ASSEMBLY, HUB AND GEAR: same as A-702.	Part of clutch assembly.		
A-904		ASSEMBLY, MOTOR SHIELD AND BUMPER: same as A-704.	Motor hash shield.		
A-905		ASSEMBLY, POTENTIOMETER BRACKET AND BUSHING: same as A-705.	Mount potentiometer R-905.		
A-906		ASSEMBLY, SECTOR ADJUSTMENT COVER AND BRACKET: same as A-706.	Adjustment cover.		
A-907		ASSEMBLY, TUNER PANEL STAKED: Panel: aluminum; overall dimensions: 7.531" long, 6.281" wide, .125" thick; eight holes .156" diameter; four .171" diameter countersunk #8-32 f.h.m. screw; one .751" diameter; one .782" diameter and countersunk 82° x .812" diameter; one .625" diameter, two .313" diameter and countersunk 82° x .343" diameter; one .144" diameter; two #4-40 top; two .128" diameter; nine #6-32 two .136" diameter; pinton stud: stainless steel; overall dimensions 1.035" long, collar 1/2" diameter #6-32 thread 1/2" deep; idler gear stud: stainless steel: 1/2" collar diameter, .691" long, #6-32 thread; dial shaft bushing: aluminum; 7/8" collar diameter, 1 1/32" long, .4365" inside diameter; bearing bushing: stainless steel 7/8" diameter 1 1/16" long, 1/4-32 tapped hole.	Parts mounting.	1	51X107703
A-908		ASSEMBLY, TUNER UNIT HOUSING: same as A-504.	Tuning housing assembly.		
A-909		BRACKET, CAM TRACK: cold rolled steel: overall dimensions: 3 15/16" long, 9/32" wide, 5/16" high, .032" thick; two .125" diameter holes, nine .145" diameter holes.	Mount cam track spring.	1	7A103519
A-910		BRACKET, DIAL INDICATOR: same as A-712.	Mount dial indicator.		
A-911		BRACKET, HOLD-DOWN: same as A-713.	Fasten tuner in shock mount.		
A-912		BRACKET, I.F. COIL MOUNTING: same as A-430.	Mount I-F coil L-901.		
A-913		BRACKET, MAIN DRIVE: same as A-715.	Main drive bracket.		
A-914		BRACKET, MOTOR DRIVE SWITCH: same as A-716.	Fasten reversing switch S-902.		
A-915		BRACKET, PANEL COVER: same as A-717.	Fasten panel cover.		
A-916		BRACKET, REVERSING SWITCH: same as A-718.	Fasten reversing switch S-901.		
A-917		BRACKET, SPRING RETAINER: same as A-411.	Fasten rotor link anti-backlash spring.		
A-918		BRACKET, TUBE: same as A-510.	Mount tube V-901.		
A-919		BRACKET, WIPER SPRING: same as A-721.	Mount wiper springs.		

MAJOR UNIT: TN-2B / APR-1

TABLE OF REPLACEABLE PARTS  
MODEL: Radio Receiving Equipment AN/APR-1 and AN/SPR-1

MAJOR UNIT: TN-2B/APR-1

Reference Symbol	Navy Stock No.	Name of Part and Description	Function	Mfr. and Desig. or AWS Type	Cont. or Gov't Dwg. or Spec. No.
A-920		BRACKET, WORM DRIVE MOUNTING: same as A-722.	Mount worm gear.		
A-921		BRACKET, WORM DRIVE SHAFT: same as A-723.	Mount worm gear.		
A-922		BUSHING, THREADED: same as A-314.	Mount cover.		
A-923		CLAMP, CABLE: same as A-204.	Fasten cables.		
A-924		CLAMP, CABLE: same as A-413.	Fasten antenna lead-in.		
A-925		CLAMP, CABLE: same as A-414.	Fasten cable to housing.		
A-926		COVER, TUNER PANEL: aluminum, black nickel finish; .064" thick stock; overall dimension 7.690" long, 6.440" wide, 2.456" high; punched for parts mounting.	Cover.	1	15B1090033
A-927		COVER, TUNER ADJUSTMENT SCREW: same as A-416.	Compensator screw cover.		
A-928		PLATE, COVER (BOTTOM): same as A-421.	Bottom cover.		
A-929		PLATE, COVER (TOP) AND WINDOW: plate cover: aluminum, 10 <sup>3</sup> / <sub>16</sub> " long, 6 <sup>5</sup> / <sub>8</sub> " wide, .062" thick; 7 holes .116" diameter; window cover; acetate: 2" wide, 2" long, .020" thick; four .104" diameter holes.	Top cover.	1	1X106142
A-930		PLATE, LOCKING: same as A-422.	Cam track screw retainer.		
A-931		PLATE, MAIN DRIVE: same as A-731.	Fasten clutch assembly.		
A-932		PLATE, MOTOR MOUNTING: same as A-732.	Mount motor B-901.		
A-933		SLEEVE, RUBBER: same as A-423.	Cable clamp.		
A-934		SLEEVE, RUBBER: same as A-206.	Cable protector.		
A-935		SPACER, VARIABLE CAM TRACK: same as A-427.	Cam track spring spacer.		
A-936		SUPPORT, MOTOR SHIELD: same as A-738.	Mount motor shield.		
A-937		ASSEMBLY, ALIGNMENT TOOL: same as A-301.	Alignment tool.		
B-901		MOTOR, PERMANENT MAGNET: same as B-701.	Drive tuning gears.		
C-901		PLATE, GRID CAPACITOR: same as C-501.	Grid coupling.		
C-902		CAPACITOR: same as C-703.	Part of hash filter.		
C-903		CAPACITOR: same as C-703.	Part of hash filter.		
C-904		LUG, ANTENNA GRID CAP: same as C-502.	R-F by-pass.		
C-905		CAPACITOR: same as C-102.	Coupling.		
C-906		CAPACITOR: same as C-101.	Diode bias.		

**MODEL: Radio Receiving Equipment AN/APR-1 and AN/SPR-1**      **TABLE OF REPLACEABLE PARTS**      **MAJOR UNIT: TN-2B/APR-1**

Reference Symbol	Navy Stock No.	Name of Part and Description	Function	Mfr. and Desig. or AWS Type	Cont. or Gov't Drawg. or Spec. No.
C-907		WASHER, CAPACITOR: same as C-409.	Filament by-pass.		
C-908		WASHER, CAPACITOR: same as C-409.	B+ by-pass.		
C-909		WASHER, CAPACITOR: same as C-409.	Hash filter.		
C-910		CAPACITOR: same as C-715.	Hash by-pass.		
C-911		CAPACITOR: same as C-716.	Hash by-pass.		
C-912		CAPACITOR: same as C-717.	Hash by-pass.		
E-901		ASSEMBLY, ANTENNA BUTTERFLY AND SOCKET: same as E-501.	Antenna tank circuit.		
E-902		ASSEMBLY, OSCILLATOR BUTTERFLY AND BARS: same as E-502.	Oscillator tank circuit.		
E-903		ASSEMBLY, TUBE, BRACKET AND CLIPS: same as E-503.	Mount tube V-901.		
E-904		BAR, GRID: same as E-504.	Tube mounting.		
E-905		BAR, PLATE: same as E-405.	Mount tube.		
E-906		CABLE, COAXIAL: same as E-506.	Antenna plug lead-in.		
E-907		CABLE, SHIELDED: same as E-708.	Connect fuse to 28 V. receptacle.		
E-908		CABLE, SHIELDED: same as E-709.	Connect motor to switch, S-901.		
E-909		CABLE, SHIELDED: same as E-711.	Connect switch, S-901 to potentiometer, R-905.		
E-910		CABLE, SHIELDED: same as E-712.	Connect motor, B-901 to potentiometer, R-905.		
E-911		CABLE, SHIELDED: same as E-713.	Connect magnetic clutch to switch, S-902.		
E-912		CABLE, SHIELDED: same as E-710.	Connect fuse, F-901 to switch S-901.		
E-913		CLIP, TUBE: same as E-407.	Mount tube.		
E-915		DIELECTRIC, ANTENNA GRID: same as E-508.	Capacitor C-904 dielectric.		
E-916		INSULATOR, FILAMENT CLIP: same as E-412.	Tube bracket insulator.		
E-917		INSULATOR, FILAMENT CLIP: same as E-413.	Tube bracket insulator.		
E-918		INSULATOR, GRID BAR: same as E-511.	Grid bar insulator.		
E-919		INSULATOR, GRID BAR: same as E-512.	Grid bar insulator.		

TABLE OF REPLACEABLE PARTS  
MODEL: Radio Receiving Equipment AN/APR-1 and AN/SPR-1

MAJOR UNIT: TN-2B/APR-1

Reference Symbol	Navy Stock No.	Name of Part and Description	Function	Mfr. and Desig. or AWS Type	Cont. or Gov't Dwg. or Spec. No.
E-920		INSULATOR, GRID CAPACITOR: same as E-513.	Fasten capacitor C-904.		
E-921		INSULATOR, FEED-THRU: same as E-718.	Feed thru.		
E-922		INSULATOR, MICA: same as E-416.	Dielectric for receptacle capacitors.		
E-923		INSULATOR, RECEPTACLE: same as E-417.	Insulators for receptacle capacitors.		
E-924		INSULATOR, SLIP RING: same as E-726.	Part of clutch assembly.		
E-925		LUG, SOLDERING: #6 mounting hole .142"-.150" holes, one .080" wire hole, .026" brass, plain bent.	Tie point.	22 #2585	29B5360
E-926		LUG, SOLDERING: same as E-423.	Tie point.		
E-927		LUG, SOLDERING: same as E-422.	Tie point.		
E-928		LUG, SOLDERING: same as E-425.	Tie point.		
E-929		LUG, SOLDERING: #6 .142"-.148" holes, one .080" wire hole; .020" thick; brass, hot tinned finish.	Tie point.	22 #2522-6	29K5261
E-930		LUG, SOLDERING: same as E-727.	Tie point.		
E-931		LUG, SOLDERING: same as E-103.	Tie point.		
E-932		LUG, SOLDERING: same as E-734.	Tie point.		
E-933		LUG, CAPACITOR: brass; overall dimensions: .020" thick; 1/2" outside diameter; .224" inside diameter.	Connecting lug.	1	29A103678
E-934		SHIELD, TUNER UNIT: aluminum; overall dimensions: 6 1/8" long, 2 7/16" wide, 1 1/4" high; .062" thick; four .156" diameter holes.	Antenna shield.	1	26B103701
E-935		SPACER, TUBE SOCKET: same as E-519.	Mount tube socket V-902.		
E-936		TERMINAL STRIP: same as E-432.	Tie point.		
E-937		TERMINAL STRIP: same as A-113.	Tie point.		
E-939		WASHER, GRID BAR: same as E-522.	Fasten grid bar.		
E-940		WASHER, TUBE SOCKET MOUNTING: same as E-523.	Fasten tube socket V-902.		
E-941		TERMINAL STRIP: same as E-430.	Tie point.		
F-901		FUSE: same as F-701.	Overload protection.		
H-901		GROMMET: same as H-401.	Feed thru.		



TABLE OF REPLACEABLE PARTS

MODEL: Radio Receiving Equipment AN/APR-1 and AN/SPR-1

MAJOR UNIT: TN-2B/APR-1

Reference Symbol	Navy Stock No.	Name of Part and Description	Function	Mfr. and Desig. or AWS Type	Cmt. or Gov't Dwg. or Spec. No.
H-902		GROMMET: same as H-701.	Feed thru.		
H-903		GROMMET: same as H-702.	Feed thru.		
H-904		LOCKWASHER: same as H-405.	Fasten plugs P-901 and P-902.		
H-905		LOCKWASHER: same as H-406.	General.		
H-906		LOCKWASHER: same as H-482.	General.		
H-907		LOCKWASHER: same as H-407.	Fasten tube clip.		
H-908		LOCKWASHER: same as H-408.	General.		
H-909		LOCKWASHER: same as H-314.	Fasten adjustment cover.		
H-910		LOCKWASHER: same as H-409.	Fasten soldering lug.		
H-911		LOCKWASHER: same as H-723.	Fasten potentiometer, R-905.		
H-912		LOCKWASHER: same as H-709.	Fasten main drive bushing.		
H-913		LOCKWASHER: same as H-708.	Fasten wiper bracket.		
H-914		LOCKWASHER: same as H-404.	General.		
H-915		LOCKWASHER: same as H-410.	General.		
H-916		LOCKWASHER: same as H-707.	Fasten fuse receptacle.		
H-917		LOCKWASHER: same as H-403.	General.		
H-918		LOCKWASHER: same as H-315.	General.		
H-919		LOCKWASHER: same as H-706.	Part of worm gear assembly.		
H-920		LOCKWASHER: same as H-482.	Fasten receptacle capacitor.		
H-921		NUT: same as H-416.	Mount cam rollers.		
H-922		NUT: same as H-420.	Fasten receptacle capacitors.		
H-923		NUT: same as H-731.	Fasten main drive bushing.		
H-924		NUT: same as H-735.	Fasten potentiometer, R-905.		
H-925		NUT: same as H-417.	Fasten tube clip.		
H-926		NUT: same as H-726.	Fasten worm gear bracket.		
H-927		NUT: same as H-734.	Fasten switch, S-902.		
H-928		NUT: same as H-728.	Fasten switch, S-901.		

MODEL: Radio Receiving Equipment AN/APR-1 and AN/SPR-1		TABLE OF REPLACEABLE PARTS			MAJOR UNIT: TN-2B/APR-1	
Reference Symbol	Navy Stock No.	Name of Part and Description	Function	Mfr. and Desig. or AWS Type	Cont. or Gov't Dwg. or Spec. No.	
H-929		NUT: same as H-422.	Fasten grid bar.			
H-930		NUT: same as H-317.	Fasten insulator feed thru.			
H-931		NUT: same as H-102.	General.			
H-932		NUT: same as H-208.	Fasten hold-down bracket.			
H-933		NUT, CAP: same as H-423.	Antenna feed thru.			
H-934		NUT, HEX.: same as H-319.	Mount chassis plug bushing.			
H-935		NUT, LOCK: same as H-732.	Lock pointers in position.			
H-936		RIVET: same as H-427.	Fasten dial lock assembly.			
H-937		RIVET: same as H-426.	Fasten dial window.			
H-938		RIVET: same as H-737.	General.			
H-939		RIVET: same as H-738.	Fasten brackets.			
H-940		RIVET, CAM ROLLER LINK: same as H-428.	Fasten helical gear to link.			
H-941		HANDLE: same as H-402.	Tuner handle.			
H-942		SCREW: 3-48 thread; 3/16" long; slotted binderhead machine screw; brass, white nickel finish.	General.	1	3S1866	
H-943		SCREW: same as H-462.	Fasten adjustment cover.			
H-944		SCREW: same as H-742.	Fasten hold-down bracket.			
H-945		SCREW: same as H-743.	Fasten handle stud.			
H-946		SCREW: same as H-760.	General.			
H-947		SCREW: same as H-778.	Fasten motor assembly.			
H-948		SCREW: same as H-810.	Fasten motor shield.			
H-949		SCREW: same as H-774.	Fasten insulator feed thru.			
H-950		SCREW: same as H-440.	Fasten tube clip.			
H-951		SCREW: same as H-441.	Fasten tube clip.			
H-952		SCREW: same as H-211.	General.			
H-953		SCREW: same as H-744.	General.			
H-954		SCREW: same as H-445.	Fasten helical gear.			

TABLE OF REPLACEABLE PARTS  
MODEL: Radio Receiving Equipment AN/APR-1 and AN/SPR-1

MAJOR UNIT: TN-2B/APR-1

Reference Symbol	Navy Stock No.	Name of Part and Description	Function	Mfr. and Desig. or AWS Type	Cont. or Gov't Dwg. or Spec. No.
H-955		SCREW: same as H-754.	General.		
H-956		SCREW: same as H-748.	General.		
H-957		SCREW: same as H-636.	General.		
H-958		SCREW: same as H-436.	Fasten top and bottom cover.		
H-959		SCREW: same as H-434.	General.		
H-960		SCREW: same as H-486.	Fasten antenna lever on antenna rotor arm.		
H-961		WASHER: same as H-474.	Gear retainer.		
H-962		SCREW: 4-40 thread, 3/8" long; slotted round head; brass, white nickel finish.	Fasten cam track assembly.	1	3S8023
H-963		SCREW: same as H-459.	Fasten cam track assembly.		
H-964		SCREW: same as H-439.	General.		
H-965		SCREW: same as H-447.	Fasten terminal strip.		
H-966		SCREW, VARIABLE CAM ADJUSTMENT: same as H-527.	Adjust cam track.		
H-967		SCREW: same as H-104.	Mount coil spacers.		
H-968		SCREW: same as H-311.	General.		
H-969		SCREW: same as H-760.	General.		
H-970		SCREW: same as H-430.	General.		
H-971		SETSCREW: same as H-464.	Fasten tuner knob.		
H-972		SETSCREW: same as H-811.	Fasten control knob.		
H-973		SETSCREW: same as H-463.	Fasten idler pinion gear.		
H-974		SETSCREW: 6-32 thread, 1/8" long; Allen head; case hardened steel, black zinc finish.	Fasten dial stop.	40	3S7148
H-975		SETSCREW: same as H-453.	General.		
H-976		STUD, COVER: same as H-784.	Mount panel cover.		
H-977		STUD, HANDLE SPACING: same as H-785.	Handle spacer.		
H-978		STUD, MAIN DRIVE PLATE: same as H-786.	Mount main drive plate.		
H-979		STUD, MOTOR MOUNTING: same as H-787.	Mount motor B-901.		
H-980		STUD, PIVOT: same as H-466.	Mount capacitor operating cam.		

TABLE OF REPLACEABLE PARTS  
MODEL: Radio Receiving Equipment AN/APR-1 and AN/SPR-1

MAJOR UNIT: TN-2B/APR-1

Reference Symbol	Navy Stock No.	Name of Part and Description	Function	Mfr. and Desig. or AWS Type	Cont. or Gov't Dwg. or Spec. No.
H-981		STUD, SPINNER KNOB: same as H-468.	Fasten knob handle.		
H-982		WASHER: same as H-792.	Mount motor assembly.		
H-983		WRENCH, ALLEN: same as H-346.	For 6-32 screw.		
H-984		WASHER: same as H-470.	Roller washer.		
H-985		WASHER: same as H-475.	Fasten capacitor C-904 and tube socket V-902.		
H-986		WASHER: same as H-797.	Fasten solder lugs.		
H-987		WASHER: same as H-474.	Gear retainer.		
H-988		WASHER: same as H-794.	Mount dial window.		
H-989		WASHER, DIAL SHAFT: same as H-480.	Dial shaft washer.		
H-990		WASHER, FUSE SPACER: same as H-802.	Mount fuse receptacle.		
H-991		WASHER, HANDLE: same as H-476.	Fasten handle.		
H-992		WASHER, INSULATING: same as H-805.	Mount insulator.		
H-993		WASHER, INSULATING: same as H-344.	Insulator for terminal strip.		
H-994		WASHER, LOCATING: same as H-806.	Mount switch.		
H-995		WASHER, SLIP RING INSULATOR: same as H-799.	Part of clutch assembly.		
H-996		WASHER, SPRING: same as H-808.	Part of clutch gear assembly.		
H-997		WASHER, SPRING: same as H-479.	Fasten handle.		
H-998		WASHER, WORM SHAFT: same as H-809.	Mount worm gear.		
H-999		WASHER, WORM SHAFT: felt; 3/8" outside diameter, 5/32" inside diameter, 1/16" thick.	Mount worm gear.	1	4K107651
J-901		RECEPTACLE, FUSE: same as E-312.	Fuse holder.		
L-901		COIL, I.F.: same as L-407.	I.F. coil.		
L-902		COIL, MAGNETIC CLUTCH: same as L-703.	Connect motor drive to manual gears.		
L-903		CHOKER, MOTOR FILTER: same as L-704.	Hash filter.		
L-904		CHOKER, MOTOR FILTER: same as L-704.	Hash filter.		
L-905		COIL, R.F. CHOKE: same as L-401.	Hash by-pass.	1	

**TABLE OF REPLACEABLE PARTS**  
**MODEL: Radio Receiving Equipment AN/APR-1 and AN/SPR-1**

**MAJOR UNIT: TN-2B/APR-1**

Reference Symbol	Navy Stock No.	Name of Part and Description	Function	Mfr. and Desig. or AWS Type	Cont. or Gov't Dwg. or Spec. No.
LC-901		ASSEMBLY, OSCILLATOR BUTTERFLY: same as LC-501.	Oscillator tank circuit.		
LC-902		ASSEMBLY, ANTENNA BUTTERFLY: same as LC-502.	Antenna tank circuit.		
O-901		ASSEMBLY, CAM LINK AND LEVER: same as O-502.	Rotate antenna butterfly.		
O-902		ASSEMBLY, HELICAL GEAR AND LINK: same as O-403.	Oscillator butterfly gear assembly.		
O-903		ASSEMBLY, SPINNER KNOB: same as O-405.	Tuner knob assembly.		
O-904		ASSEMBLY, SPINNER LOCK: same as O-406.	Handle shaft lock.		
O-905		BALL, BEARING: same as O-704.	Part of worm gear assembly.		
O-906		BALL, BEARING: same as O-705.	Part of worm gear assembly.		
O-907		BALL, BEARING: same as O-509.	Drive shaft bearing.		
O-908		BEARING, OILITE: same as O-409.	Gear mounting.		
O-909		BEARING, OILITE: same as O-408.	Gear bearing.		
O-910		BEARING, OPERATING CAM: same as O-410.	Capacitor operating cam bearing.		
O-911		BUSHING, MAIN DRIVE: same as O-711.	Mount main drive plate.		
O-912		BUSHING, OPERATING CAM: same as O-411.	Mount operating cam.		
O-913		BUSHING, WORM SHAFT ADJUSTMENT: same as O-714.	Part of worm gear assembly.		
O-914		BALL, BEARING: same as O-707.	Part of clutch gear assembly.		
O-915		CAM, CAPACITOR OPERATING: same as O-513.	Vary antenna butterfly tuning.		
O-916		CAP, PLUG: same as O-514.	Mount antenna lead-in.		
O-917		CAM, SWITCH ACTUATOR: same as O-716.	Actuate reversing switch S-901.		
O-918		CAM, SWITCH ACTUATOR: same as O-721.	Actuate reversing switch S-901.		
O-919		COLLAR, MAIN DRIVE: same as O-719.	Part of clutch gear assembly.		
O-920		CLAMP, LOCKING: same as O-717.	Lock pointers in position.		
O-921		COLLAR, DIAL LOCK: same as O-718.	Dial lock collar.		
O-923		DIAL, TUNER: aluminum #24 ST; black; 47/32" diameter.	Dial scale readings in megacycles.		34B107944
O-924		DISC, SPINNER KNOB: same as O-418.	Locking disc.	1	

MODEL: Radio Receiving Equipment AN / APR-1 and AN / SPR-1		TABLE OF REPLACEABLE PARTS		MAJOR UNIT: TN-2B / APR-1	
Reference Symbol	Navy Stock No.	Name of Part and Description	Function	Mfr. and Desig. or AWS Type	Cont. or Gov't Drawg. or Spec. No.
O-925		GEAR, BACKLASH: same as O-421.	Part of tuning gear assembly.		
O-926		GEAR, BACKLASH: same as O-420.	Part of tuning gear assembly.		
O-927		GEAR, BACKLASH: same as O-723.	Part of tuning gear assembly.		
O-928		GEAR, BACKLASH: same as O-724.	Part of tuning gear assembly.		
O-929		GEAR, HELICAL: same as O-423.	Vary oscillator butterfly.		
O-930		HANDLE, KNOB: same as O-424.	Knob handle.		
O-931		HINGE, COVER ADJUSTMENT: same as O-731.	Cover hinge.		
O-932		HOUSING, CLUTCH: same as O-732.	Clutch housing.		
O-933		HUB, DIAL: same as O-733.	Mount dial.		
O-934		HUB, DIAL GEAR: same as O-734.	Gear hub.		
O-935		INDICATOR, DIAL: same as O-457.	Dial indicator.		
O-936		KNOB, SPINNER: same as O-426.	Tuner knob.		
O-937		LEVER, ANTENNA ROTOR: same as O-759.	Mounts on antenna rotor stud.		
O-938		LINK, ANTENNA ROTOR CAM: same as O-528.	Connect capacitor cam to rotor lever.		
O-939		PINION: same as O-434.	Part of tuning gear assembly.		
O-940		PINION, DRIVER: same as O-739.	Part of clutch gear assembly.		
O-941		PINION, IDLER: same as O-432.	Part of tuning gear assembly.		
O-942		PINION, IDLER: same as O-433.	Part of tuning gear assembly.		
O-943		POINTER, ADJUSTMENT: same as O-537.	Cam screw adjustment pointer.		
O-944		POINTER, DIAL: same as O-744.	Sector adjust.		
O-945		POINTER, DIAL: same as O-745.	Sector adjust.		
O-946		RACE, BALL: same as O-748.	Part of worm gear assembly.		
O-947		RACE, BALL BEARING: same as O-747.	Part of clutch assembly.		
O-948		RING, SLIP: same as O-749.	Part of clutch assembly.		
O-949		ROLLER, CAM: same as O-436.	Antenna cam roller.		
O-950		ROLLER, VARIABLE CAM: same as O-437.	Cam track roller.		

TABLE OF REPLACEABLE PARTS  
MODEL: Radio Receiving Equipment AN/APR-1 and AN/SPR-1

Reference Symbol	Navy Stock No.	Name of Part and Description	Function	Mfr. and Desig. or AWS Type	Cont. or Gov't Drawg. or Spec. No.
O-951		SHAFT, CAM ROLLER: same as O-439.	Mount roller cams and pointer.		
O-952		SHAFT DIAL: same as O-753.	Part of tuning assembly.		
O-953		SHAFT, MAIN DRIVE: same as O-754.	Part of clutch assembly.		
O-954		SHAFT, WORM DRIVE: same as O-755.	Drive clutch.		
O-955		SHIM, TUBE BRACKET: same as O-756.	Tube bracket shim.		
O-956		SLEEVE: same as O-759.	Shock mounting.		
O-957		SLEEVE, DIAL SHAFT: same as O-758.	Dial shaft sleeve.		
O-958		SLEEVE, DIAL SHAFT: same as O-757.	Dial shaft sleeve.		
O-959		SPACER, INDICATOR: same as O-446.	Indicator spacer.		
O-960		SPRING, CAM ARM: stainless steel; .030" thick, 5/16" inside diameter.	Cam arm spring.	1	41A107298
O-961		SPRING, CAM ROLLER TRACK: stainless steel or phosphor bronze; overall dimensions: 3 1/4" long, 1/4" wide, .005" thick; one .122" diameter hole.	Cam track roller spring.	1	41A103521
O-962		SPRING, CAM TRACK: same as O-449.	Cam track roller spring.		
O-963		SPRING, COIL RETAINING: same as O-766.	Magnetic coil spring.		
O-964		SPRING, COMPRESSION COIL: same as O-450.	Anti-backlash gear spring.		
O-965		SPRING, COMPRESSION COIL: same as O-451.	Anti-backlash gear spring.		
O-966		SPRING, HINGE: same as O-769.	Adjustment cover spring.		
O-967		SPRING, SECTOR COVER SNAP: same as O-772.	Lock adjustment cover.		
O-968		SPRING, OPERATING CAM: same as O-452.	Operating cam spring.		
O-969		SPRING, POINTER ADJUSTMENT: same as O-453.	Pointer spring adjustment.		
O-970		SPRING, WIPER: same as O-773.	Clutch contact.		
O-971		SPRING, WIPER: same as O-774.	Clutch contact.		
O-972		STOP, DIAL: stainless steel; overall dimensions: 1/4" high, 1/4" wide, 1/4" thick; one 6-32 thread.	Dial stop.	1	46A107258
O-974		WINDOW, DIAL: same as O-775.	Dial window.		
O-975		LINK, CAM ROLLER: same as O-429.	Part of oscillator gear assembly.		
O-976		COUPLING, FLEXIBLE: same as O-720.	Motor shaft coupling.		

**TABLE OF REPLACEABLE PARTS**  
**MODEL: Radio Receiving Equipment AN/APR-1 and AN/SPR-1**

**MAJOR UNIT: TN-2B/APR-1**

Reference Symbol	Navy Stock No.	Name of Part and Description	Function	Mfr. and Desig. or AWS Type	Cont. or Gov't Dwg. or Spec. No.
O-977		BALL, BEARING: same as O-707.	Part of clutch gear.	1	1X109017
O-978		ASSEMBLY, DIAL AND HUB: composed of dial O-923, and hub O-933.	Part of tuning assembly.		
P-901		PLUG, CHASSIS: same as P-401.	Antenna plug.		
P-902		PLUG, CHASSIS: same as P-401.	I-F plug.		
R-901		RESISTOR: same as R-403.	Plate dropping.		
R-902		RESISTOR: same as R-402.	Grid leak.		
R-903		RESISTOR: same as R-406.	I-F load.		
R-904		RESISTOR: same as R-101.	Grid load.		
R-905		POTENTIOMETER: same as R-708.	Motor speed control.		
S-901		SWITCH, TOGGLE: same as S-701.	Motor reversing switch.		
S-902		SWITCH, TOGGLE: same as S-702. or: SWITCH, TOGGLE: same as S-301.	AUTO-MANUAL switch.		
V-901		RADIO TUBE: same as V-401.	Oscillator.		
V-902		RADIO TUBE: same as V-401.	Mixer.		
X-901		RECEPTACLE, PLUG: same as X-401.	Filament receptacle.		
X-902		RECEPTACLE, PLUG: same as X-401.	B+ receptacle.		
X-903		RECEPTACLE, PLUG: same as X-401.	28 V. D-C receptacle.		
X-904		SOCKET, TUBE: same as X-504.			



TABLE OF REPLACEABLE PARTS  
MODEL: Radio Receiving Equipment AN/APR-1 and AN/SPR-1

MODEL: Radio Receiving Equipment AN/APR-1 and AN/SPR-1		MAJOR UNIT: Tuning Unit TN-1B/APR-1			
Reference Symbol	Navy Stock No.	Name of Part and Description	Function	Mfr. and Desig. or AWS Type	Cont. or Gov't Dwg. or Spec. No.
A-1001		ASSEMBLY, BRACKET AND BUMPER: same as A-701.	Adjust worm gear.		
A-1002		ASSEMBLY, BRACKET AND BUSHING: same as A-601.	Parts mounting.		
A-1003		ASSEMBLY, HOUSING AND LUG: same as A-703.	Clutch housing.		
A-1004		ASSEMBLY, HUB AND GEAR: same as A-702.	Part of clutch assembly.		
A-1005		ASSEMBLY, MOTOR SHIELD AND BUMPER: same as A-704.	Motor hash shield.		
A-1006		ASSEMBLY, MOUNTING STRIP AND BUSHING: same as A-603.	Filter strip parts mounting.		
A-1007		ASSEMBLY, POTENTIOMETER BRACKET AND BUSHING: same as A-705.	Mount potentiometer R-1008.		
A-1008		ASSEMBLY, SECTOR ADJUSTMENT COVER AND BRACKET: same as A-706.	Adjustment cover.		
A-1009		ASSEMBLY, TUNER PANEL STAKFD: aluminum; 7.531" long, 6.281" wide, .125" thick; pinion stud of stainless steel; idler gear stud of stainless steel; dial shaft bushing of aluminum; stop stud of brass; bearing bushing of stainless steel.	Parts mounting.	1	51X107713
A-1010		BRACKET, HOLD-DOWN: same as A-713.	Fasten tuner in shock.		
A-1011		BRACKET, MAIN DRIVE: same as A-715.	Main drive bracket.		
A-1012		BRACKET, MOTOR DRIVE SWITCH: same as A-716.	Fasten switch S-1002.		
A-1013		BRACKET, PANEL COVER: same as A-717.	Fasten panel cover.		
A-1014		BRACKET, REVERSING SWITCH: same as A-718.	Fasten reversing switch S-1001.		
A-1015		BRACKET, TUNING ASSEMBLY: same as A-606.	Parts mounting.		
A-1016		BRACKET, WIPER SPRING: same as A-721.	Mount wiper springs.		
A-1017		BRACKET, WORM DRIVE MOUNTING: same as A-722.	Mount worm gear assembly.		
A-1018		BRACKET, WORM DRIVE SHAFT: same as A-723.	Mount worm gear.		
A-1019		BUSHING, THREADED: same as A-314.	Mount tuner housing to front panel.		
A-1020		CLAMP, CABLE: same as A-204.	Fasten cable to chassis.		
A-1021		CLAMP, CABLE: same as A-414.	Fasten cable.		
A-1022		COVER, TUNER PANEL: aluminum; black wrinkle finish; 7.69" long, 6.44" wide, 2.456" high; .064" thick stock; punched for parts mounting.	Front panel cover.	1	15B109032
A-1023		HOUSING, TUNER: same as A-610.	Tuner housing.		

TABLE OF REPLACEABLE PARTS  
MODEL: Radio Receiving Equipment AN/APR-1 and AN/SPR-1

MAJOR UNIT: Tuning Unit TN-1B/APR-1

Reference Symbol	Navy Stock No.	Name of Part and Description	Function	Mfr. and Desig. or AWS Type	Cont. or Gov't Dug. or Spec. No.
A-1024		PLATE, COVER: same as A-612.	Tuner cover.		
A-1025		PLATE, MAIN DRIVE: same as A-731.	Fasten clutch assembly.		
A-1026		PLATE, MOTOR MOUNTING: same as A-732.	Mount worm gear.		
A-1027		SLEEVE, RUBBER: same as A-206.	Cable protector.		
A-1028		SPACER, VAR-CAM TRACK: same as A-427.	Cam track spring spacer.		
A-1029		SUPPORT, MOTOR SHIELD: same as A-738.	Mount motor shield.		
A-1030		ASSEMBLY, ALIGNMENT TOOL: same as A-301.	Alignment tool.	1	15K110285
A-1031		CHEST: spare parts 24.240" long x 12.06" high x 15.120" wide overall; Galvin Special; (steel case; has hasp for padlock on cover; no trays or compartment inside).	Pack spare parts.	1	15K110284
A-1032		CHEST: spare parts 24.240" long x 9.06" high x 12.120" wide overall; Galvin Special; (steel case; has hasp for padlock on cover no trap or compartments inside).	Pack spare parts.	1	15D110283
A-1033		CHEST: spare parts; 18.240" long x 12.06" high x 12.120" wide overall; Galvin Special; (steel case has hasp on cover for padlock; has no trays inside).	Pack spare parts.	1	15D109767
A-1034		CHEST: spare parts cold rolled steel; 18,000" long x 12,000" wide x 9,000" high overall; Galvin Special; (has four (4) compartments inside; has hasp for padlock).	Pack spare parts.		
B-1001		MOTOR, PERMANENT MAGNET: same as B-701.	Drives gear assembly.		
C-1001		CAPACITOR: same as C-601.	Plate coupling.		
C-1002		CAPACITOR: same as C-131.	Grid coupling.		
C-1003		CAPACITOR: same as C-703.	Part of hash filter.		
C-1004		CAPACITOR: same as C-703.	Part of hash filter.		
C-1005		CAPACITOR: same as C-603.	Oscillator trimmer.		
C-1006		CAPACITOR: same as C-603.	R-F trimmer.		
C-1007		CAPACITOR: same as C-605.	Oscillator section of gang.		
C-1008		CAPACITOR: same as C-605.	R-F section of gang.		
C-1009		CAPACITOR: same as C-607.	Oscillator padder.		
C-1010		CAPACITOR: same as C-404.	Image trap capacitors.		

TABLE OF REPLACEABLE PARTS  
MODEL: Radio Receiving Equipment AN/APR-1 and AN/SPR-1

385		MAJOR UNIT: Tuning Unit TN-1B/APR-1	
Reference Symbol	GALVIN Navy Stock No.	8-548 56 picas DS Name of Part and Description	Function
C-1011		CAPACITOR: fixed; mica; .50 micro-microfarads, ±10%, 400 V. D-C working; color coded; green, black, black, silver, 1 1/16" long, 7/16" wide, 1/64" thick; axial leads.	Image trap capacitors.
C-1012		CAPACITOR: same as C-1011.	Image trap capacitors.
C-1013		CAPACITOR: same as C-404.	Image trap capacitors.
C-1014		CAPACITOR: same as C-407.	Mixer cathode by-pass.
C-1015		CAPACITOR: same as C-614.	I-F trap capacitors.
C-1016		CAPACITOR: same as C-614.	I-F trap capacitors.
C-1017		CAPACITOR: same as C-407.	I-F coupling.
C-1018		CAPACITOR: same as C-610.	R-F by-pass.
C-1019		WASHER, CAPACITOR: same as C-409.	Filament receptacle.
C-1020		WASHER, CAPACITOR: same as C-409.	B+ receptacle.
C-1021		WASHER, CAPACITOR: same as C-409.	28 V. D-V power source.
C-1022		CAPACITOR: same as C-715.	Hash by-pass.
C-1022		CAPACITOR: same as C-716.	Hash by-pass.
C-1024		CAPACITOR: same as C-717.	Hash by-pass.
E-1001		CABLE, COAXIAL: same as E-601.	Antenna cable.
E-1002		CABLE, SHIELDED: same as E-708.	Connect fuse to 28 volt receptacle.
E-1003		CABLE, SHIELDED: same as E-709.	Connect motor to switch.
E-1004		CABLE, SHIELDED: same as E-711.	Connect switch S-1001 to potentiometer.
E-1005		CABLE, SHIELDED: same as E-712.	Connect magnetic clutch to switch.
E-1006		CABLE, SHIELDED: same as E-713.	Connect motor B-1001 to potentiometer R-1008.
E-1007		CABLE, SHIELDED: same as E-710.	Connect fuse F-1001 to switch.
E-1008		CABLE, SHIELDED: same as E-602.	I-F cable.
E-1009		INSULATOR, FEED THRU: same as E-718.	Feed thru.

Mfr. and  
Desig. or  
AWS Type  
2  
1468X

Cont. or  
Gov't Dwg.  
or Spec. No.  
21B6578

TABLE OF REPLACEABLE PARTS  
MODEL: Radio Receiving Equipment AN/APR-1 and AN/SPR-1

Reference Symbol	Navy Stock No.	Name of Part and Description	Function	Mfr. and Desig. or AWS Type	Cont. or Gov't Dug. or Spec. No.
E-1010		INSULATOR, MICA: same as E-416.	Capacitor dielectric C-1019, C-1020, C-1021.		
E-1011		INSULATOR, RECEPTACLE: same as E-417.	Capacitor dielectric C-1019, C-1020, C-1021.		
E-1012		INSULATOR, SLIP RING: same as E-726.	Part of clutch assembly.		
E-1013		LUG, SOLDERING: same as E-727.	Tie point.		
E-1014		LUG, SOLDERING: same as E-103.	Tie point.		
E-1015		LUG, SOLDERING: same as E-425.	Tie point.		
E-1016		LUG, SOLDERING: same as E-734.	Tie point.		
E-1017		LUG, CONTACT: same as E-605.	Tie point.		
E-1018		LUG, SOLDERING: same as E-422.	Tie point.		
E-1019		LUG, SOLDERING: same as E-607.	Tie point.		
E-1020		SLUG, I-F COIL: same as E-610.	Tuning slug L-1006.		
E-1021		STRIP, TERMINAL: same as E-611.	Tie point.		
E-1022		STRIP, TERMINAL: same as E-614.	Tie point.		
E-1023		STRIP, TERMINAL: same as E-432.	Tie point.		
E-1024		ASSEMBLY, IMAGE TRAP: composed of mounting strip A-1006, coil L-1002, terminal strip E-1022, capacitor C-1010 and capacitor C-1013, capacitor C-1011, capacitor C-1012, coil L-1001 and dial L-1003.	Filter.		1X109027
E-1025		CABLE, COAXIAL: 22' stranded Arglas wire, outer shield of #36 A.W.G. tinned copper, wire braided.	I-F cable.	1	30A101849
F-1001		FUSE: same as F-701.	Overload protection.		
H-1001		GROMMET, NEOPRENE: same as H-401.	General.		
H-1002		GROMMET, RUBBER: same as H-701.	Feed thru.		
H-1003		GROMMET, RUBBER: same as H-702.	Feed thru.		
H-1004		HANDLE: same as H-402.	Tuner handle.		
H-1005		LOCK WASHER: same as H-404.	General.		
H-1006		LOCK WASHER: same as H-723.	Fasten potentiometer R-1008.		
H-1007		LOCK WASHER: same as H-315.	General.		
H-1008		LOCK WASHER: same as H-706.	Part of worm gear assembly.		

TABLE OF REPLACEABLE PARTS  
MODEL: Radio Receiving Equipment AN/ APR-1 and AN/ SPR-1

Reference Symbol	Navy Stock No.	Name of Part and Description	Function	Mfr. and Desig. or AWS Type	Cont. or Gov't Dwg. or Spec. No.
H-1009		LOCKWASHER: same as H-410.	General.		
H-1010		LOCKWASHER: same as H-709.	Fasten main drive bushing.		
H-1011		LOCKWASHER: same as H-708.	Fasten wiper bracket.		
H-1012		LOCKWASHER: same as H-707.	Fasten fuse receptacle.		
H-1013		LOCKWASHER: same as H-403.	General.		
H-1014		LOCKWASHER: same as H-407.	Fasten tube sockets.		
H-1015		LOCKWASHER: same as H-408.	General.		
H-1016		LOCKWASHER: same as H-405.	Mount housing bushing.		
H-1017		LOCKWASHER: same as H-482.	Fasten capacitors.		
H-1018		LOCKWASHER: same as H-314.	Fasten adjustment cover.		
H-1019		NUT: same as H-735.	Fasten potentiometer R-1008.		
H-1020		NUT: same as H-734.	Fasten switch S-1001.		
H-1021		NUT: same as H-728.	General.		
H-1022		NUT: same as H-726.	Fasten worm gear.		
H-1023		NUT: same as H-317.	General.		
H-1024		NUT: same as H-102.	Fasten capacitors.		
H-1025		NUT: same as H-731.	Fasten main drive bushing.		
H-1026		NUT: same as H-417.	Fasten tube sockets.		
H-1027		NUT: same as H-206.	Fasten terminal strip.		
H-1028		NUT, CAP: same as H-423.	Antenna feed-thru.		
H-1029		NUT, LOCK: same as H-732.	Lock pointers in position.		
H-1030		NUT, LOCKING: same as H-650.	Fasten I-F coil.	1	2A104721
H-1031		NUT: same as H-420.	Fasten receptacles X-1001, X-1002, X-1003.		
H-1032		NUT: same as H-208.	Fasten hold-down bracket.		
H-1033		PIN, STOP: same as H-620.	Tuning mechanism stop.		
H-1034		RIVET: same as H-427.	Fasten dial lock assembly.		

TABLE OF REPLACEABLE PARTS  
MODEL: Radio Receiving Equipment AN/APR-1 and AN/SPR-1

MAJOR UNIT: Tuning Unit TN-1B/APR-1

Reference Symbol	GALVIN Navy Stock No.	8-548 56 picas Name of Part and Description	DS	Function	Mfr. and Desig. or AWS Type	Cont. or Gov't Dwg. or Spec. No.
H-1035		WASHER: same as H-794.		Mount dial window.		
H-1036		RIVET: same as H-737.		General.		
H-1037		SCREW: same as H-478.		General.		
H-1038		SCREW: same as H-104.		General.		
H-1039		SCREW: same as H-211.		Fasten terminal strip.		
H-1040		SCREW: same as H-334.		General.		
H-1041		SCREW: same as H-754.		General.		
H-1042		SCREW: same as H-774.		Fasten insulator feed thru.		
H-1043		SCREW: same as H-810.		Fasten motor shield.		
H-1045		SCREW: same as H-760.		General.		
H-1046		SCREW: same as H-434.		Fasten dial indicator.		
H-1047		SCREW: same as H-636.		General.		
H-1048		SCREW: same as H-430.		General.		
H-1049		SCREW: same as H-331.		General.		
H-1050		SCREW: same as H-452.		Mount terminal strip filter assembly.		
H-1051		SCREW: same as H-462.		Fasten adjustment cover.		
H-1052		SCREW: same as H-742.		Fasten hold down bracket.		
H-1053		SETScrew: same as H-453.		General.		
H-1054		SETScrew: same as H-446.		Fasten antenna.		
H-1055		SETScrew: same as H-464.		Fasten tuner knob.		
H-1056		STUD, COVER: same as H-784.		Mount panel cover.		
H-1057		STUD, HANDLE SPACING: same as H-785.		Handle spacer.		
H-1058		STUD, MAIN DRIVE PLATE: same as H-786.		Mount main drive plate.		
H-1059		STUD, SPINNER KNOB: same as H-468.		Fasten knob handle.		
H-1060		WASHER: same as H-474.		Gear retainer.		
H-1061		WASHER: same as H-797.		Fasten solder lugs.		

TABLE OF REPLACEABLE PARTS  
MODEL: Radio Receiving Equipment AN/APR-1 and AN/SPR-1

MAJOR UNIT: Tuning Unit TN-1B/APR-1

Reference Symbol	Navy Stock No.	Name of Part and Description	Function	Mfr. and Desig. or AWS Type	Cont. or Gov't Dwg. or Spec. No.
H-1062		WASHER: same as H-792.	Mount motor assembly.		
H-1063		SETSCREW: same as H-811.			
H-1064		WASHER, DIAL SHAFT: same as H-480.	Dial shaft washer.		
H-1065		WASHER, FUSE SPACER: same as H-802.	Mount fuse receptacle.		
H-1066		WASHER, HANDLE: same as H-476.	Tuner handle.		
H-1067		WASHER, INSULATING: same as H-805.	Mount insulator.		
H-1068		WASHER, LOCATING: same as H-806.	Mount switch S-1002.		
H-1069		WASHER, SLIP RING INSULATOR: same as H-799.	Part of clutch assembly.		
H-1070		WASHER, SPRING: same as H-808.	Part of clutch gear assembly.		
H-1071		WASHER, WORM SHAFT: same as H-809.	Mount worm gear.		
H-1072		WRENCH, ALLEN: same as H-345.	For 6-32 screws.		
H-1073		WRENCH, ALLEN: same as H-346.	For 8-32 screws.		
J-1001		RECEPTACLE, FUSE: same as H-701.	Fuse holder.		
L-1001		COIL, IMAGE FILTER: .048" solid tinned copper wire, 3/8" inside diameter loop.	Image filter.	1	24A107963
L-1002		COIL, COUPLING: same as L-404.	Image filter.		
L-1003		COIL, IMAGE FILTER: same as L-1001.	Image filter.		
L-1004		COIL, TN-1 FILTER: same as L-603.	I-F trap indicator.		
L-1005		COIL, TN-1 FILTER: same as L-603.	I-F trap indicator.		
L-1006		COIL, I-F: same as L-601.	I-F coil.		
L-1007		COIL, R-F CHOKE: same as L-401.	Filament R-F choke.		
L-1008		COIL, MAGNETIC CLUTCH: same as L-703.	Operate magnetic clutch.		
L-1009		CHOKE, MOTOR FILTER: same as L-704.	Hash filter inductors.		
L-1010		CHOKE, MOTOR FILTER: same as L-704.	Hash filter inductor.		
L-1011		CHOKE: same as L-905.	Hash by-pass.		
O-1001		ASSEMBLY, SPINNER KNOB: same as O-405.	Tuner knob assembly.		
O-1002		ASSEMBLY, SPINNER LOCK: same as O-406.	Handle shaft lock.		

TABLE OF REPLACEABLE PARTS

MAJOR UNIT: Tuning Unit TN-1B/APR-1

MODEL: Radio Receiving Equipment AN/APR-1 and AN/SPR-1

Reference Symbol	Navy Stock No.	Name of Part and Description	Function	Mfr. and Desig. or AWS Type	Cont. or Gov't Dwg. or Spec. No.
O-1003		BALL, BEARING: same as O-707.	Part of clutch gear assembly.		
O-1004		BALL, BEARING: same as O-704.	Part of worm gear assembly.		
O-1005		BALL, BEARING: same as O-705.	Part of worm gear assembly.		
O-1006		BEARING, OILITE: same as O-408.	Gear bearing.		
O-1007		BEARING, OILITE: same as O-409.	Gear mounting.		
O-1008		BUSHING, MAIN DRIVE: same as O-711.	Mount main drive plate.		
O-1009		CAM, SWITCH ACTUATING: same as O-721.	Actuate reversing switch S-1001.		
O-1010		CAM, SWITCH, ACTUATING: same as O-716.	Actuate reversing switch S-1001.		
O-1011		CLAMP, LOCKING: same as O-717.	Lock pointers in position.		
O-1012		CLAMP, TUBE RETAINER: same as O-606.	Fasten tube.		
O-1013		COLLAR, DIAL LOCK: same as O-718.	Dial lock collar.		
O-1014		COLLAR, MAIN DRIVE: same as O-719.	Part of clutch assembly.		
O-1015		COUPLING, SLIDE: same as O-608.	Shaft coupling.		
O-1016		DISC, SPINNER KNOB: same as O-418.	Locking disc.		
O-1017		GEAR, BACKLASH: same as O-723.	Tuning gear assembly.		
O-1018		GEAR, BACKLASH: same as O-724.	Tuning gear assembly.		
O-1019		GEAR, BACKLASH: same as O-421.	Tuning gear on dial shaft.		
O-1020		GEAR, BACKLASH: same as O-420.	Tuning gear on dial shaft.		
O-1021		GROMMET, RUBBER: same as O-614.	Tube retainer cushion.		
O-1022		HANDLE, KNOB: same as O-424.	Knob handle.		
O-1023		HOUSING, CLUTCH: same as O-732.	Clutch housing.		
O-1024		HINGE, COVER ADJUSTMENT: same as O-731.	Cover hinge.		
O-1025		HUB, DIAL: same as O-733.	Mount dial.		
O-1026		HUB, DIAL GEAR: same as O-734.	Gear hub.		
O-1027		INDICATOR, DIAL: same as O-457.	Indicator dial.		
O-1028		KNOB, SPINNER: same as O-426.	Tuner knob.		
O-1029		PINION: same as O-434.	Part of tuning gear assembly.		



TABLE OF REPLACEABLE PARTS

MODEL: Radio Receiving Equipment AN/APR-1 and AN/SPR-1

MAJOR UNIT: Tuning Unit TN-1B/APR-1

Reference Symbol	Navy Stock No.	Name of Part and Description	Function	Mfr. and Desig. or AWS Type	Cont. or Gov't Dwg. or Spec. No.
O-1030		PINION, DRIVER: same as O-739.	Part of clutch gear assembly.		
O-1031		PINION, IDLER: same as O-432.	Part of tuning gear assembly.		
O-1032		PINION, IDLER GEAR: same as O-620.	Part of tuning gear assembly.		
O-1033		POINTER, DIAL: same as O-744.	Sector dial.		
O-1034		POINTER, DIAL: same as O-745.	Sector dial.		
O-1035		RACE, BALL BEARING: same as O-747.	Part of clutch assembly.		
O-1036		RING, SLIP: same as O-749.	Part of clutch.		
O-1037		SHAFT, DIAL: stainless steel; overall dimensions $3\frac{7}{16}$ " long, $\frac{5}{8}$ " diameter.	Dial shaft.	1	47A106975
O-1038		SHAFT, MAIN DRIVE: same as O-754.	Part of clutch assembly.		
O-1039		SHAFT, WORM DRIVE: same as O-755.	Drive clutch.		
O-1040		SLEEVE, DIAL SHAFT: same as O-757.	Dial shaft sleeve.		
O-1041		SLEEVE, DIAL SHAFT: same as O-758.	Dial shaft sleeve.		
O-1042		SLEEVE, NEOPRENE: same as O-759.	Shock mounting.		
O-1043		SPACER, INDICATOR: same as O-446.	Indicator spacer.		
O-1044		SPRING, COIL RETAINING: same as O-766.	Magnetic coil spring.		
O-1045		SPRING, COMPRESSION COIL: same as O-450.	Anti-backlash gear spring.		
O-1046		SPRING, COMPRESSION COIL: same as O-451.	Anti-backlash gear spring.		
O-1047		SPRING, HINGE: same as O-769.	Adjustment cover spring.		
O-1048		SPRING, SECTOR COVER SNAP: same as O-772.	Cover hinge.		
O-1049		SPRING, TUBE RETAINER: same as O-631.	Tube retainer.		
O-1050		SPRING, WIPER: same as O-773.	Clutch contacts.		
O-1051		SPRING, WIPER: same as O-774.	Clutch contact.		
O-1052		WINDOW, DIAL: same as O-775.	Dial window.		
O-1053		COUPLING, FLEXIBLE: same as O-720.	Motor shaft coupling.		
O-1054		ASSEMBLY, DIAL AND HUB: composed of hub O-1035 and aluminum dial $4\frac{7}{32}$ " outside diameter, black finish, white letters.	Dial scale readings in megacycles.	1	1X107390
P-1001		PLUG, CHASSIS: same as P-401.	Antenna receptacle.		

TABLE OF REPLACEABLE PARTS

MAJOR UNIT: Tuning Unit TN-1B / APR-1

Reference Symbol	Navy Stock No.	Name of Part and Description	Function	Mfr. and Desig. or AWS Type	Cont. or Gov't Dwg. or Spec. No.
P-1002		PLUG, CHASSIS: same as P-401.	I-F receptacle.		
R-1001		RESISTOR: same as R-601.	Plate loading.		
R-1002		RESISTOR: same as R-607.	Grid bias, V-1001.		
R-1003		RESISTOR: same as R-132.	Grid leak.		
R-1004		RESISTOR: same as R-603.	Cathode bias.		
R-1005		RESISTOR: same as R-406.	I-F trap resistors.		
R-1006		RESISTOR: same as R-406.	I-F trap resistors.		
R-1007		RESISTOR: same as R-601.	B+ filter.		
R-1008		POTENTIOMETER: same as R-708.	Motor speed control.		
S-1001		SWITCH, TOGGLE: same as S-701.	Motor reversing switch.		
		of			
S-1002		SWITCH, TOGGLE: same as S-301.			
V-1001		SWITCH, TOGGLE: same as S-702.			
V-1002		TUBE, RADIO: same as V-601.	AUTO-MANUAL switch.		
X-1001		TUBE, RADIO: same as V-601.	Oscillator.		
X-1002		SOCKET, TUBE: same as X-604.	Mixer.		
X-1003		SOCKET, TUBE: same as X-604.	Tube socket V-1001.		
X-1004		RECEPTACLE, PLUG: same as X-401.	Tube socket V-1002.		
X-1005		RECEPTACLE, PLUG: same as X-401.	Filament receptacle.		
			B+ receptacle.		
			28 V. D-C receptacle.		

**MANUFACTURERS' NAMES AND ADDRESSES**

<i>Mfr. No.</i>	<i>Name</i>	<i>Street Address</i>	<i>City</i>	<i>State</i>
1.	Galvin Manufacturing Corporation	4545 W. Augusta Blvd.	Chicago	Illinois
2.	Aerovox Company	742 Belleville Ave.	New Bedford	Massachusetts
3.	Arrow, Hart & Hegeman	103 Hawthorne St.	Hartford	Connecticut
4.	Allen-Bradley	118 W. Greenfield Ave.	Milwaukee	Wisconsin
5.	American-Phenolic	1830 S. 54th St.	Cicero	Illinois
6.	Atlantic India Rubber Company	1453 W. Van Buren St.	Chicago	Illinois
7.	Chicago Rivet Machine Company	9600 W. Jackson Blvd.	Bellwood	Illinois
8.	Chicago Transformer Corporation	3501 Addison St.	Chicago	Illinois
9.	Cinch Manufacturing Company	2339 W. Van Buren St.	Chicago	Illinois
10.	Coronet Electric Company	353 W. Grand Ave.	Chicago	Illinois
11.	Drake Manufacturing Company	1713 W. Hubbard St.	Chicago	Illinois
12.	International Resistance Company	18 W. Chelton	Philadelphia	Pennsylvania
13.	Jones, H. B. & Company	2300 Wabansia	Chicago	Illinois
14.	Ken-Rad Corporation		Owensboro	Kentucky
15.	Littlefuse Corporation	4757 N. Ravenswood	Chicago	Illinois
16.	Mallory, P. R. & Company	1941 Thomas St.	Washington	D. C.
18.	Salisbury, W. H. & Company	401 N. Morgan St.	Chicago	Illinois
19.	Sangamo Electric Company	1935 Funk St.	Long Island	New York
21.	Simpson Electric Company	5216 W. Kinzie St.	Chicago	Illinois
22.	Shakeproof Lockwasher	2501 N. Keeler Ave.	Chicago	Illinois
23.	Stackpole Carbon Company	Elk County	St. Mary's	Pennsylvania
24.	Thomson, J. L. Manufacturing Company	17 N. Loomis St.	Chicago	Illinois
25.	Tinnerman Products, Inc.	6319 S. Ashland Ave.	Chicago	Illinois
26.	United Screw & Bolt	2513 W. Cullerton St.	Chicago	Illinois
27.	Utah Radio Products	820 Orleans St.	Chicago	Illinois
28.	Tung Sol Radio Tube	95 8th Ave.	Newark	New Jersey
29.	Zierich Manufacturing Company	385 Gerard Ave.	New York	New York
30.	Cornell-Dubilier	1000 Hamilton	S. Plainfield	New Jersey
31.	Chrysler Corporation	Amplex Division	Detroit	Michigan
32.	Dorff Manufacturing Corporation, C. J.	15 S. Aberdeen St.	Chicago	Illinois
33.	Erie Resistor Corporation	644 W. 12th St.	Erie	Pennsylvania
34.	Fast Company, J. E.	3123 N. Crawford Ave.	Chicago	Illinois
35.	Gates Washer Company	2949 N. Elston Ave.	Chicago	Illinois
36.	General Radio Company	30 State St.	Cambridge	Massachusetts
37.	Mica Insulator Company	542 S. Dearborn St.	Chicago	Illinois
38.	New Departure, Div. of General Motors	1940 Plant St.	Bristol	Connecticut
39.	Parisian Novelty Company	Western Ave. at 35th St.	Chicago	Illinois
40.	Pedersen Bros.	625 W. Washington Blvd.	Chicago	Illinois
41.	Quadriga Manufacturing Corporation	213 W. Grand Ave.	Chicago	Illinois
42.	R.C.A. Manufacturing Company		Camden	New Jersey
	R.C.A. Manufacturing Company		Harrison	New Jersey
	R.C.A. Manufacturing Company	151 W. Side Ave.	Jersey City	New Jersey
43.	Rolyan Corporation	214 W. Institute Place	Chicago	Illinois
44.	Smith, F. H. & Company	3047 Carrol Ave.	Chicago	Illinois
45.	Stewart Stamping	621 E. 216th	New York	New York
46.	Swanson, Jerry, Inc.	2315 Calhoun St.	Ft. Wayne	Indiana
47.	Svania Electric Products, Inc.		Emporium	Pennsylvania
48.	Speer Resistor Corporation		St. Mary's	Pennsylvania
49.	Milled Screw Products Company	2016 W. Lake St.	Chicago	Illinois
50.	Tinnerman Products, Inc.	6319 S. Ashland Ave.	Chicago	Illinois
51.	F. W. Sickles Co.		Springfield	Massachusetts
52.	Cutler-Hammer Co.	400 W. Madison St.	Chicago	Illinois
53.	Paragon Die Casting	5851 Dickens St.	Chicago	Illinois
54.	Strom Steel	1855 S. 54th St.	Cicero	Illinois
55.	General Motors Corp., Delco Division		Rochester	New York
56.	Underwood Electric Co.	3120 W. Grand Ave.	Chicago	Illinois
57.	White Way Electric			
58.	Lord Manufacturing Co.		Erie	Pennsylvania
59.	U. S. Rubber Co.	Pennsylvania Ordinance P.O. Box 300	Williamsport	Pennsylvania
60.	Reliable Screw Machine	4431 W. Rice St.	Chicago	Illinois

\*Unless otherwise specified, all numbers appearing on Column 6, are Galvin Manufacturing Drawing Numbers.

RESTRICTED  
AN-16-30APR-1-3  
NAVSHIPS 900, 483A

MANUFACTURERS' NAMES AND ADDRESSES

No.	Name	Address	City	State
1	Garvin Manufacturing Corporation	1415 W. Adams Blvd.	Chicago	Illinois
2	Arcox Company	741 Belleville Ave.	New Bedford	Massachusetts
3	Arcox Hart & Higman	103 Hawthorn St.	Hartford	Connecticut
4	Allen Bradley	118 W. Grand Ave.	Milwaukee	Wisconsin
5	American Plastic	1032 S. State St.	Caro	Illinois
6	Arthur Jahn Rubber Company	1415 W. Van Buren St.	Chicago	Illinois
7	Chicago River Machine Company	3000 W. Jackson Blvd.	Chicago	Illinois
8	Chicago Transfer Corporation	3201 Addison St.	Chicago	Illinois
9	Cinch Manufacturing Company	1339 W. Van Buren St.	Chicago	Illinois
10	Conover Electric Company	41 W. Grand Ave.	Chicago	Illinois
11	Dixie Manufacturing Company	211 W. Hubbard St.	Chicago	Illinois
12	International Resistor Company	19 W. Madison	Philadelphia	Pennsylvania
13	Loew, H. B. & Company	2300 W. Washington	Chicago	Illinois
14	Kay-Rob Corporation	177 N. Ravenswood	Chicago	Illinois
15	Lincoln Corporation	1941 Monroe St.	Washington	D.C.
16	Melroy, P. K. & Company	191 N. Madison St.	Chicago	Illinois
17	Salisbury, W. H. & Company	191 N. Madison St.	Chicago	Illinois
18	Sargant Electric Company	191 N. Madison St.	New York	New York
19	Sampson Electric Company	2218 W. Jackson St.	Chicago	Illinois
20	Shelton Lockwasher	1201 N. Kasold Ave.	Chicago	Illinois
21	Shelton Lockwasher	1111 Adams	St. Mary's	Pennsylvania
22	Shelton Lockwasher	17 N. Laconia St.	Chicago	Illinois
23	Thomas, J. I. Manufacturing Company	619 S. Ashland Ave.	Chicago	Illinois
24	Thompson Products Inc.	2113 W. Calhoun St.	Chicago	Illinois
25	United Screw & Bolt	820 Orleans St.	Chicago	Illinois
26	Urb Radio Products	23 1/2 Ave.	New York	New York
27	Urb Radio Tube	23 1/2 Ave.	New York	New York
28	Urb Radio Manufacturing Company	287 Grand Ave.	New York	New York
29	Urb Radio Manufacturing Company	1600 Hamilton	St. Paul	Minnesota
30	Urb Radio	Ames Division	Chicago	Illinois
31	Urb Radio	445 S. Aberdeen St.	Chicago	Illinois
32	Urb Radio	644 W. 12th St.	Chicago	Illinois
33	Urb Radio	2113 N. Calhoun Ave.	Chicago	Illinois
34	Urb Radio	1047 N. Grand Ave.	Chicago	Illinois
35	Urb Radio	30 1/2 Ave.	Chicago	Illinois
36	Urb Radio	245 S. Dearborn St.	Chicago	Illinois
37	Urb Radio	1910 Platt St.	Chicago	Illinois
38	Urb Radio	Western Ave. at 21st St.	Chicago	Illinois
39	Urb Radio	611 W. Washington Blvd.	Chicago	Illinois
40	Urb Radio	211 W. Grand Ave.	Chicago	Illinois
41	Urb Radio	Chicago	Chicago	Illinois
42	Urb Radio	Chicago	Chicago	Illinois
43	Urb Radio	Chicago	Chicago	Illinois
44	Urb Radio	Chicago	Chicago	Illinois
45	Urb Radio	Chicago	Chicago	Illinois
46	Urb Radio	Chicago	Chicago	Illinois
47	Urb Radio	Chicago	Chicago	Illinois
48	Urb Radio	Chicago	Chicago	Illinois
49	Urb Radio	Chicago	Chicago	Illinois
50	Urb Radio	Chicago	Chicago	Illinois
51	Urb Radio	Chicago	Chicago	Illinois
52	Urb Radio	Chicago	Chicago	Illinois
53	Urb Radio	Chicago	Chicago	Illinois
54	Urb Radio	Chicago	Chicago	Illinois
55	Urb Radio	Chicago	Chicago	Illinois
56	Urb Radio	Chicago	Chicago	Illinois
57	Urb Radio	Chicago	Chicago	Illinois
58	Urb Radio	Chicago	Chicago	Illinois
59	Urb Radio	Chicago	Chicago	Illinois
60	Urb Radio	Chicago	Chicago	Illinois

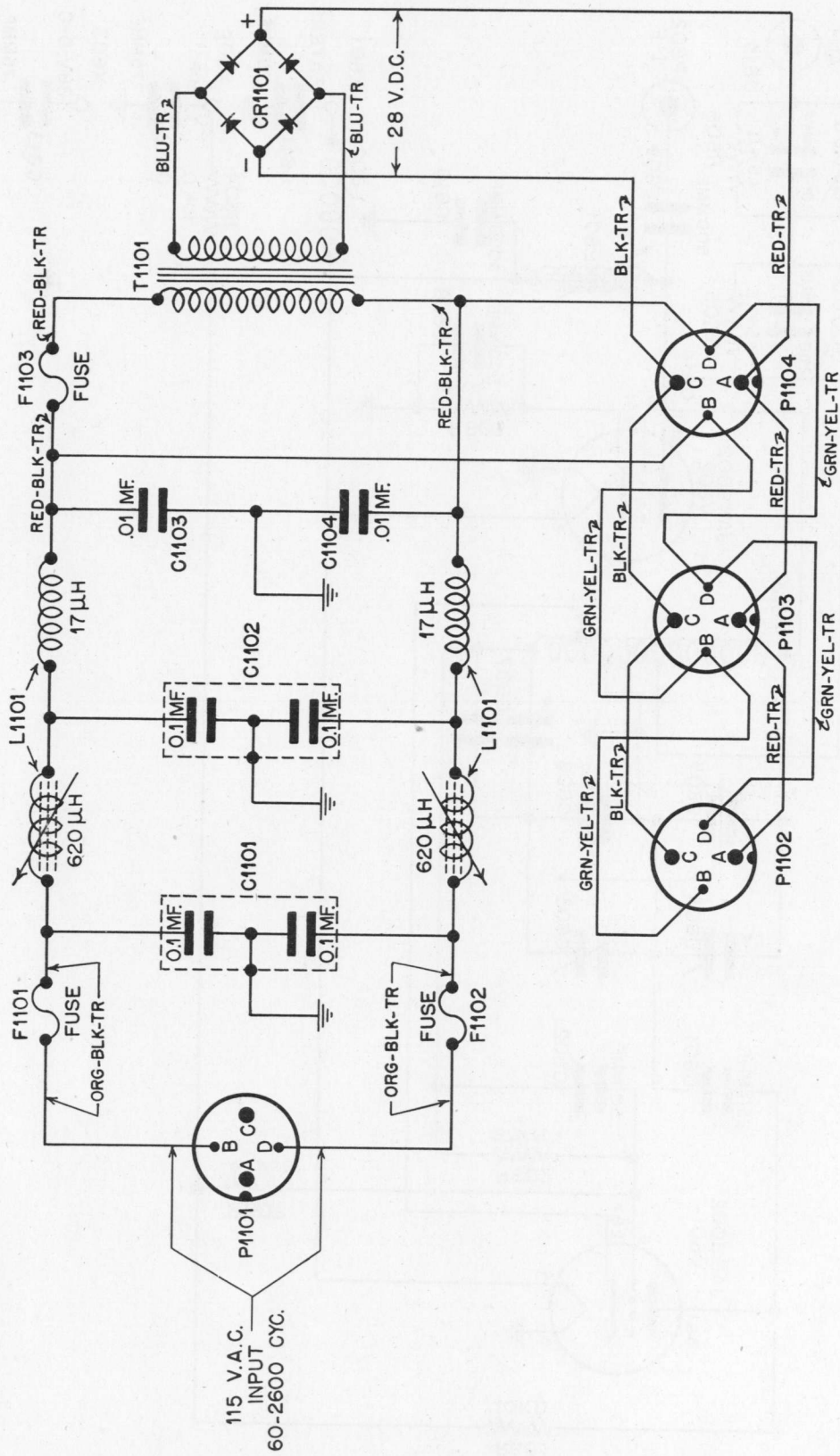

Figure 8-1. Rectifier Filter PP-183/SPR-1, Schematic.

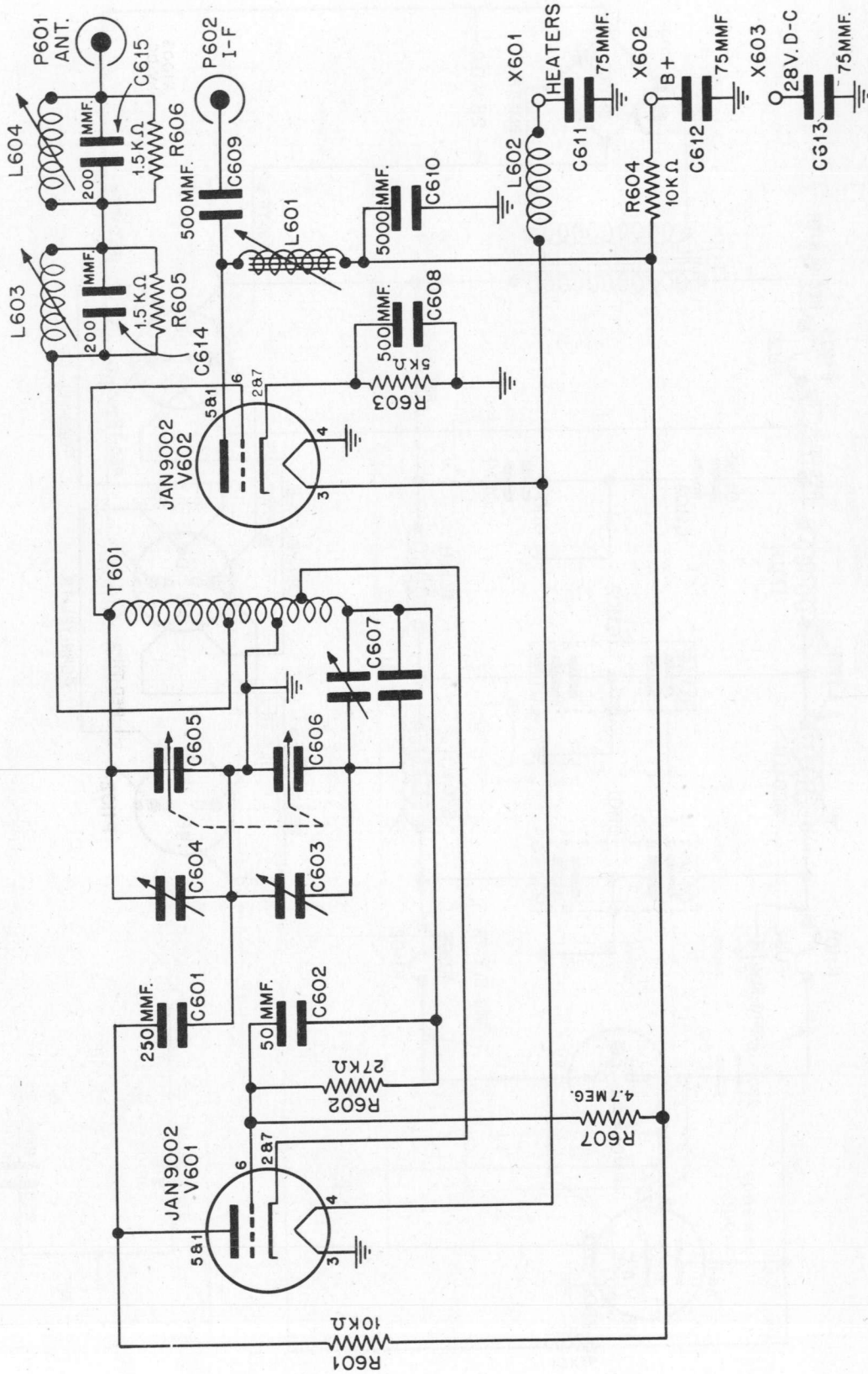

Figure 8-2. Tuning Unit TN-1/APR-1, Schematic Diagram.

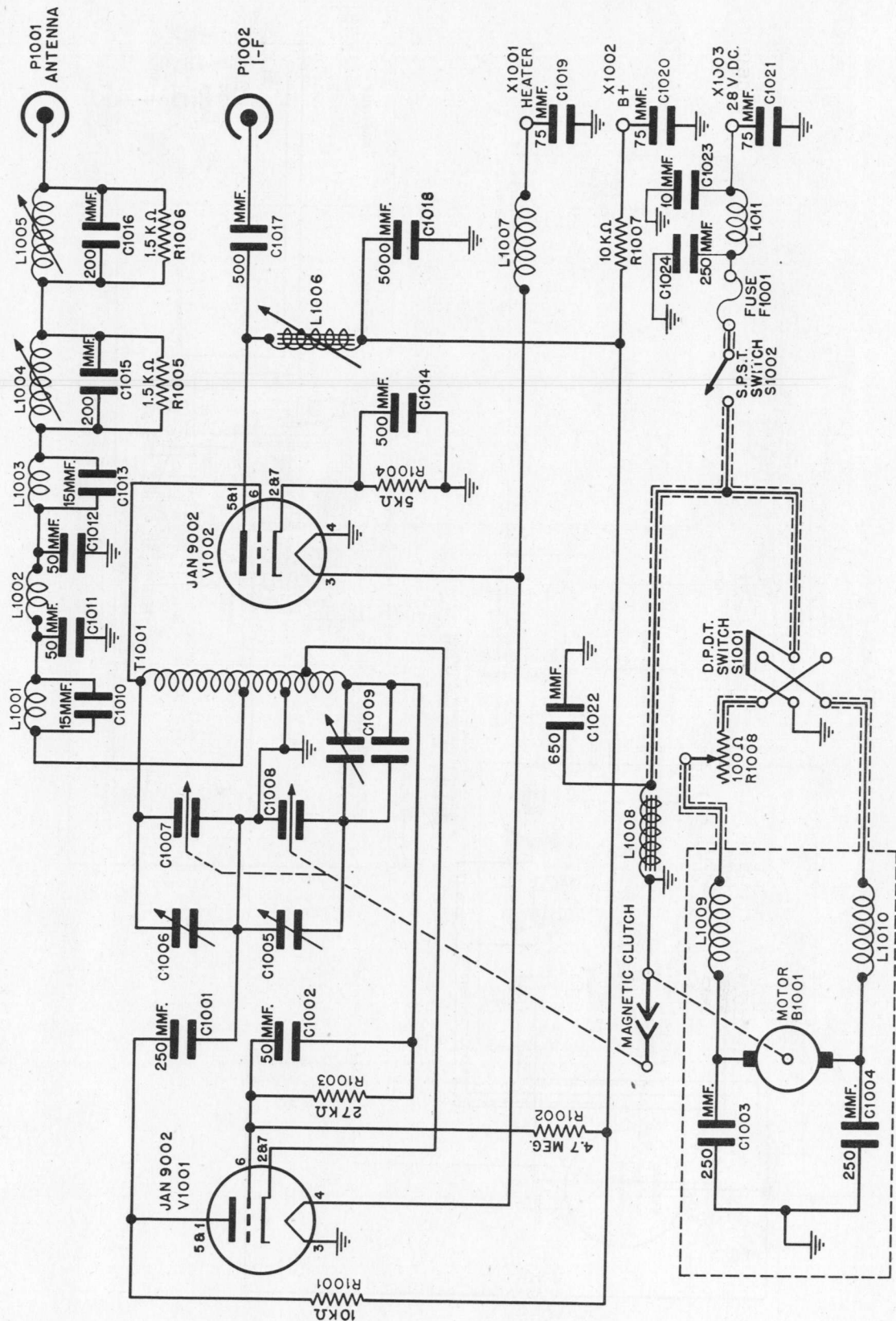

Figure 8-3. Tuning Unit TN-1B/APR-1, Schematic Diagram.





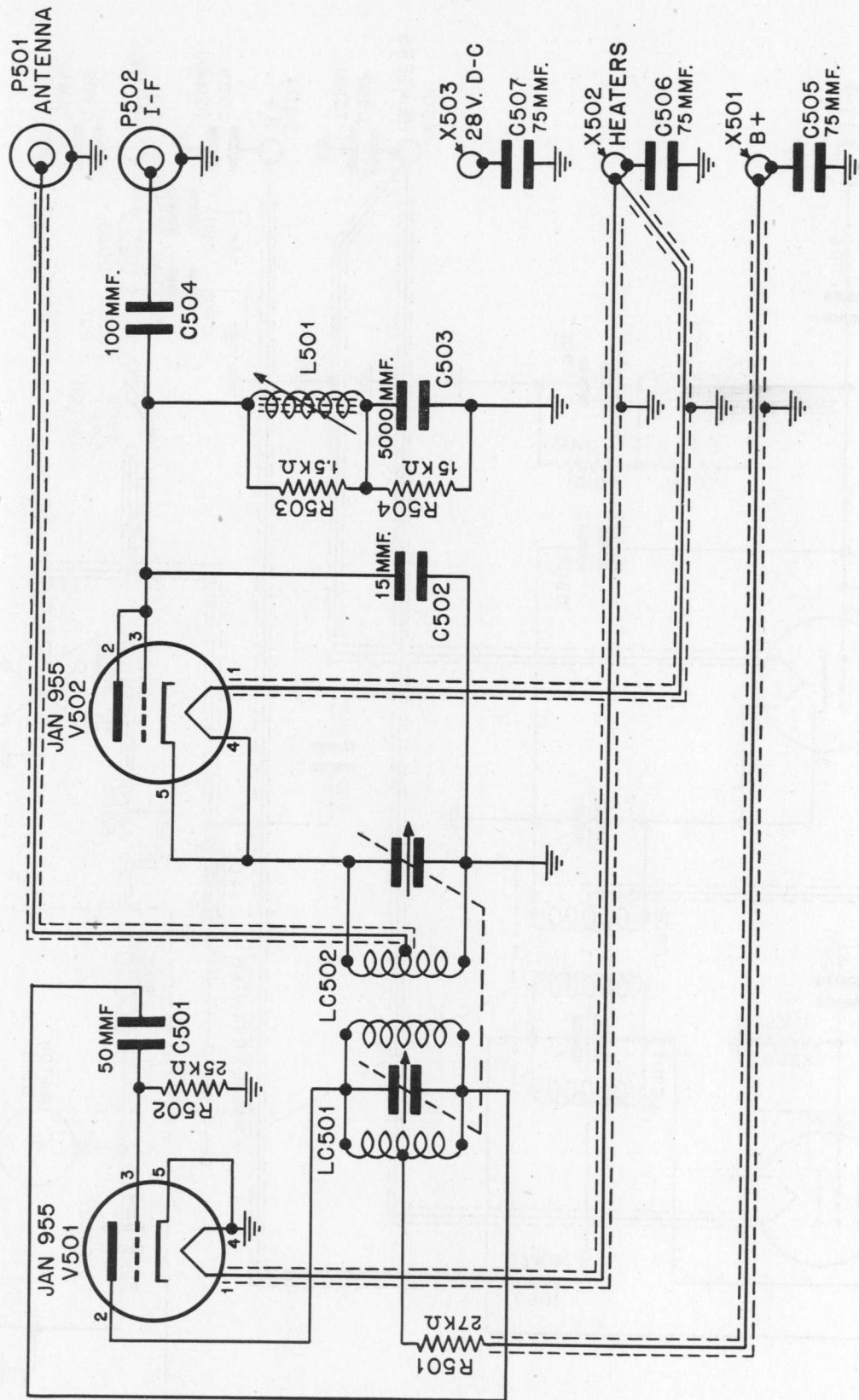

Figure 8-5. Tuning Unit, TN-2/APR-1, Schematic Diagram.

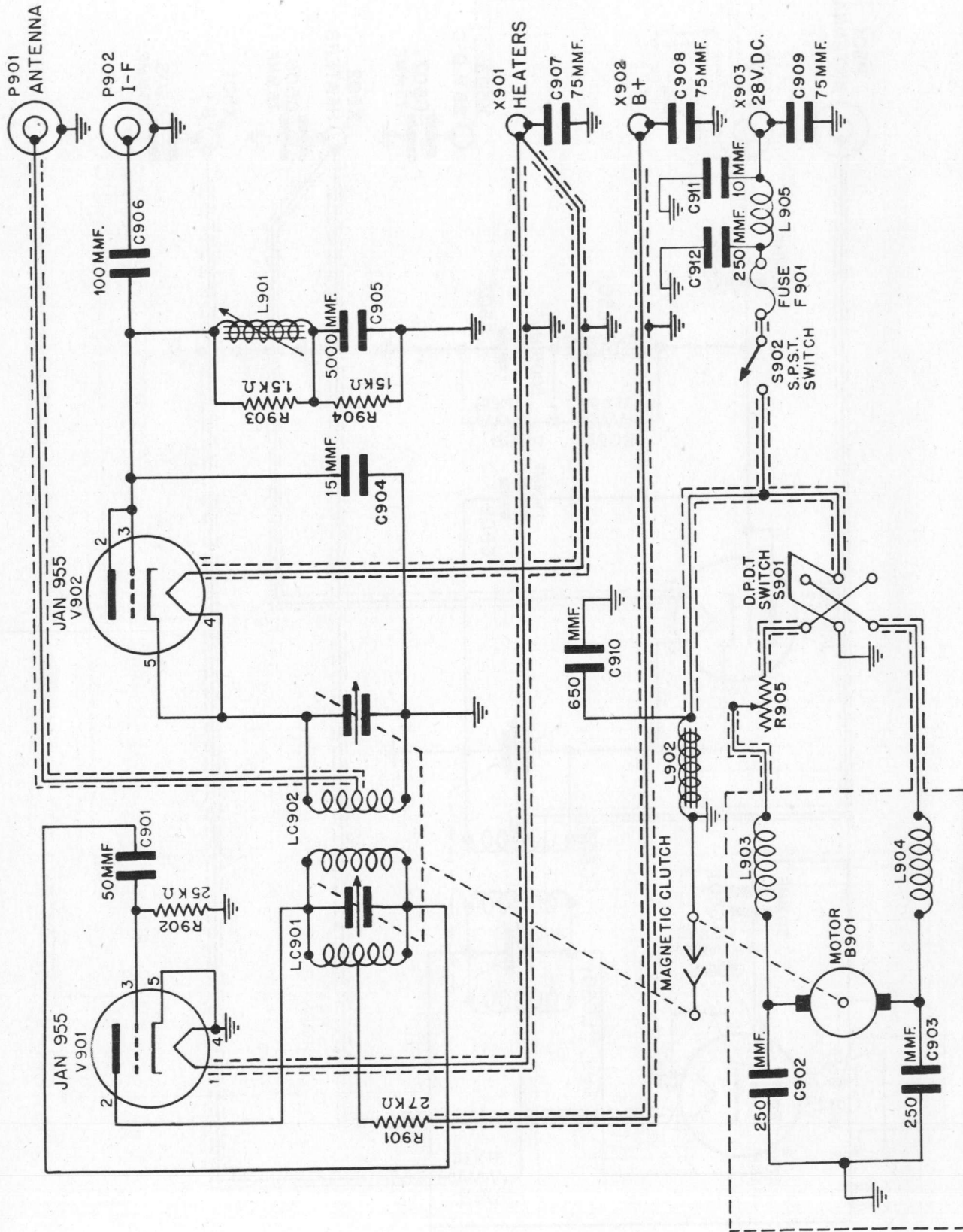

Figure 8-6. Tuning Unit TN-2B/APR-1, Schematic Diagram.

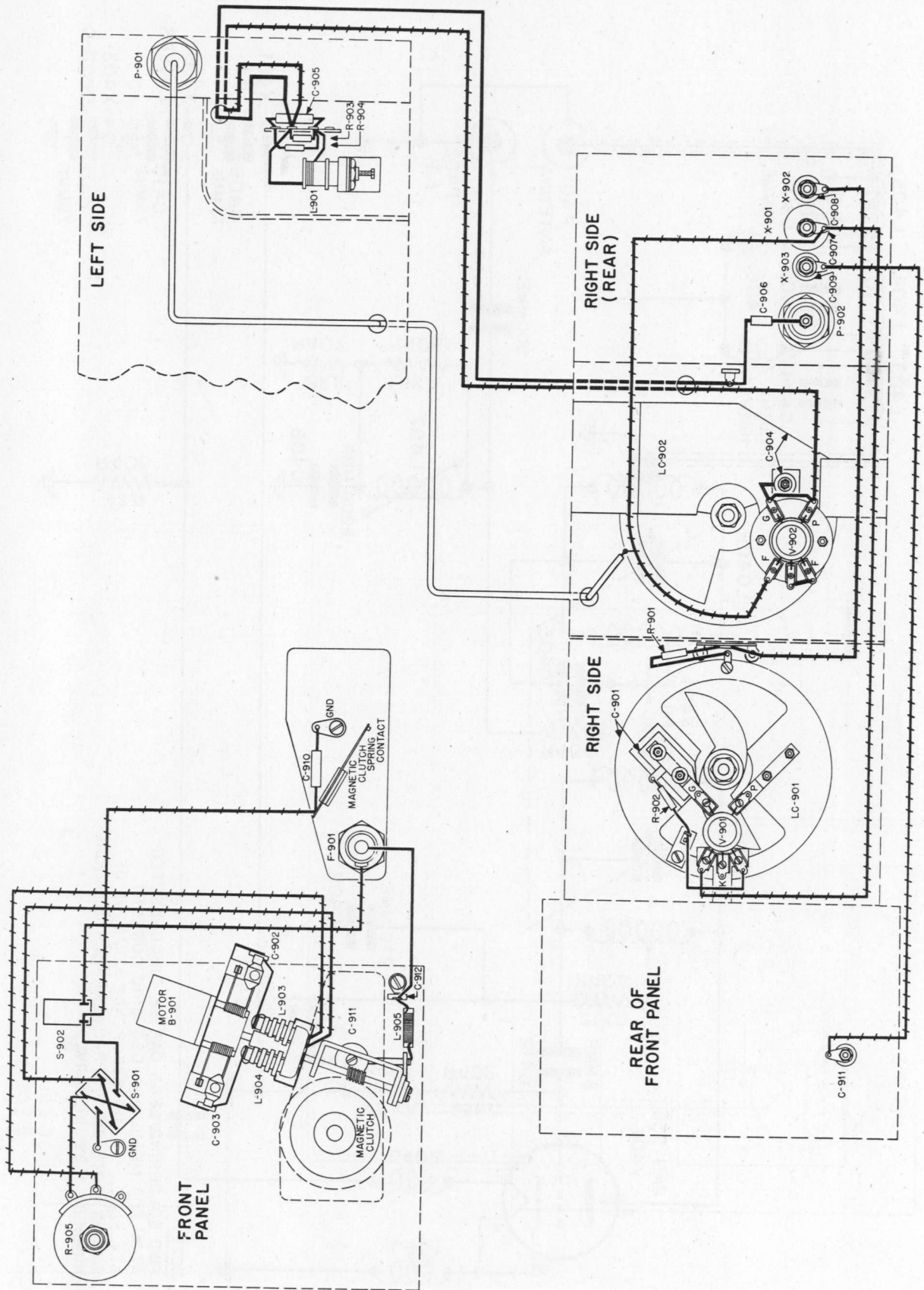
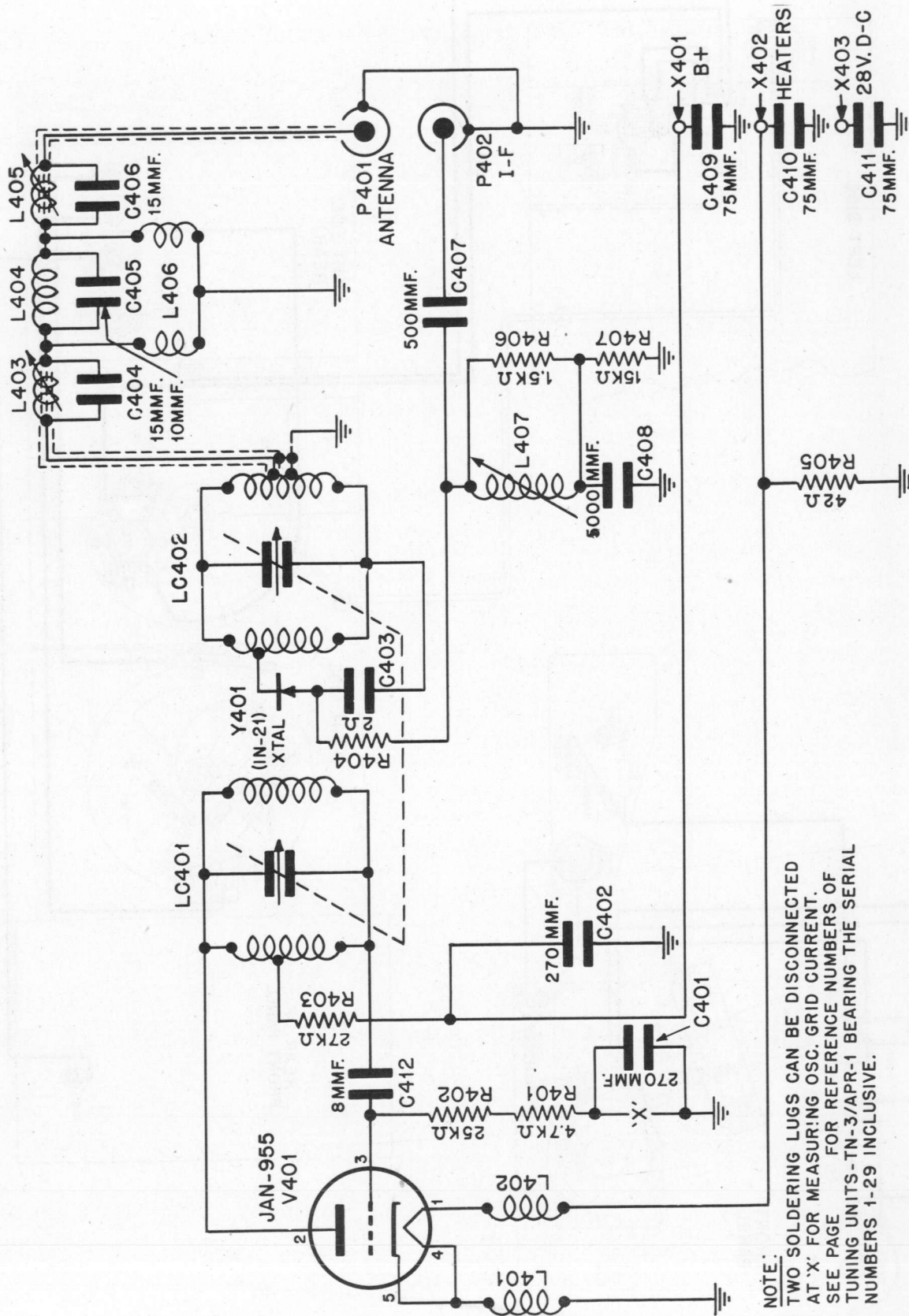

Figure 8-7. Tuning Unit TN-2B/APR-1, Practical Wiring Diagram.



NOTE:  
TWO SOLDERING LUGS CAN BE DISCONNECTED AT 'X' FOR MEASURING OSC. GRID CURRENT. SEE PAGE FOR REFERENCE NUMBERS OF TUNING UNITS-TN-3/APR-1 BEARING THE SERIAL NUMBERS 1-29 INCLUSIVE.

Figure 8-8. Tuning Unit TN-3/APR-1, Schematic Diagram.

TUNING UNIT TN-3/APR-1, CROSS REFERENCE CHART

<i>A</i>	<i>B</i>	<i>A</i>	<i>B</i>
C401.....	C101	L406.....	L106
C402.....	C102	L407.....	L107
C403.....	C103	LC401.....	LC101
C404.....	C104	LC402.....	LC102
C405.....	C105	P401.....	P101
C406.....	C106	P402.....	P102
C407.....	C107	R401.....	R101
C408.....	C108	R402.....	R103
C409.....	C109	R403.....	R102
C410.....	C110	R404.....	R104
C411.....	C111	R405.....	R105
L401.....	L101	V401.....	V101
L402.....	L102	X401.....	S101
L403.....	L103	X402.....	S102
L404.....	L104	X403.....	S103
L405.....	L105		

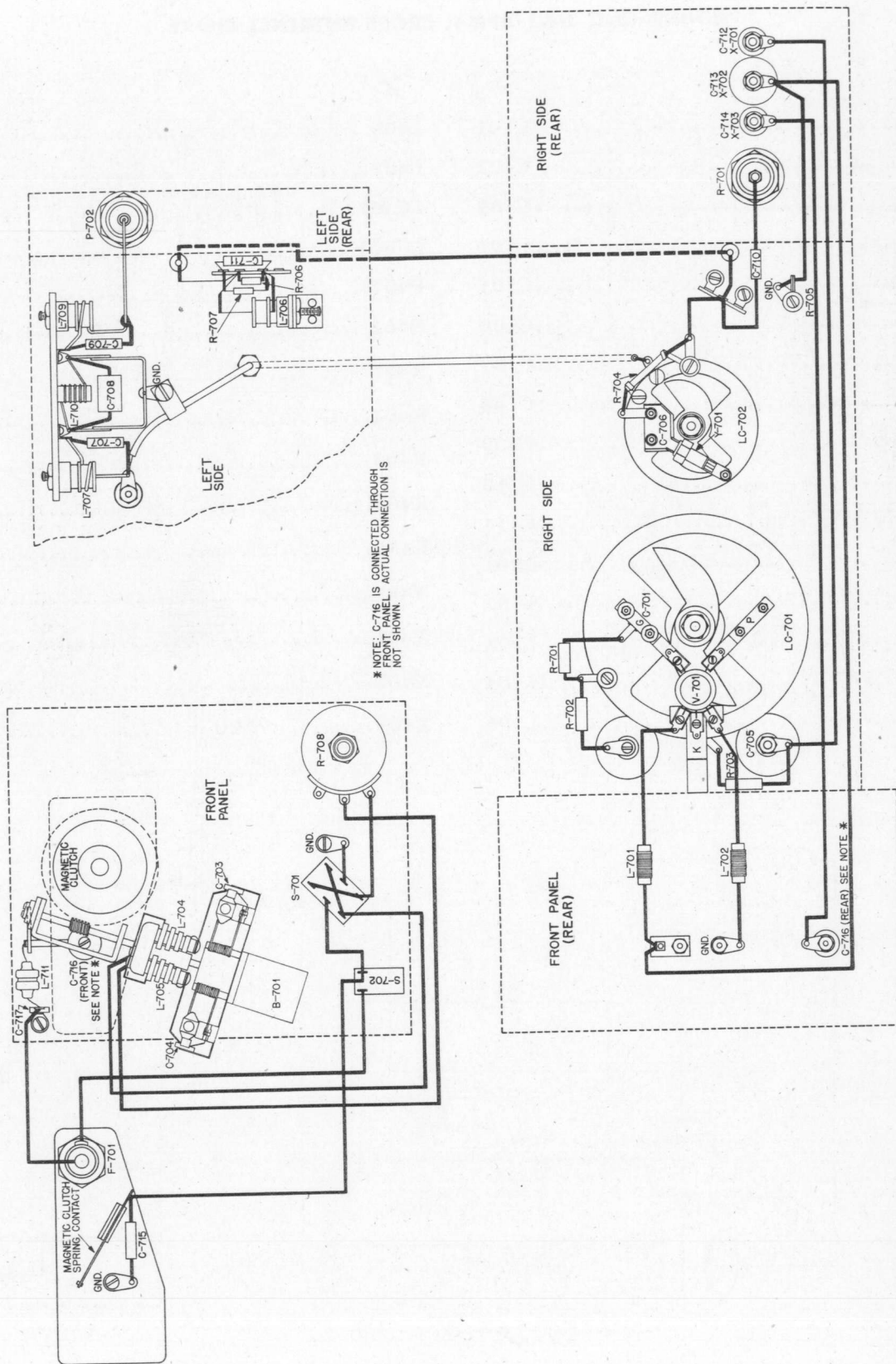
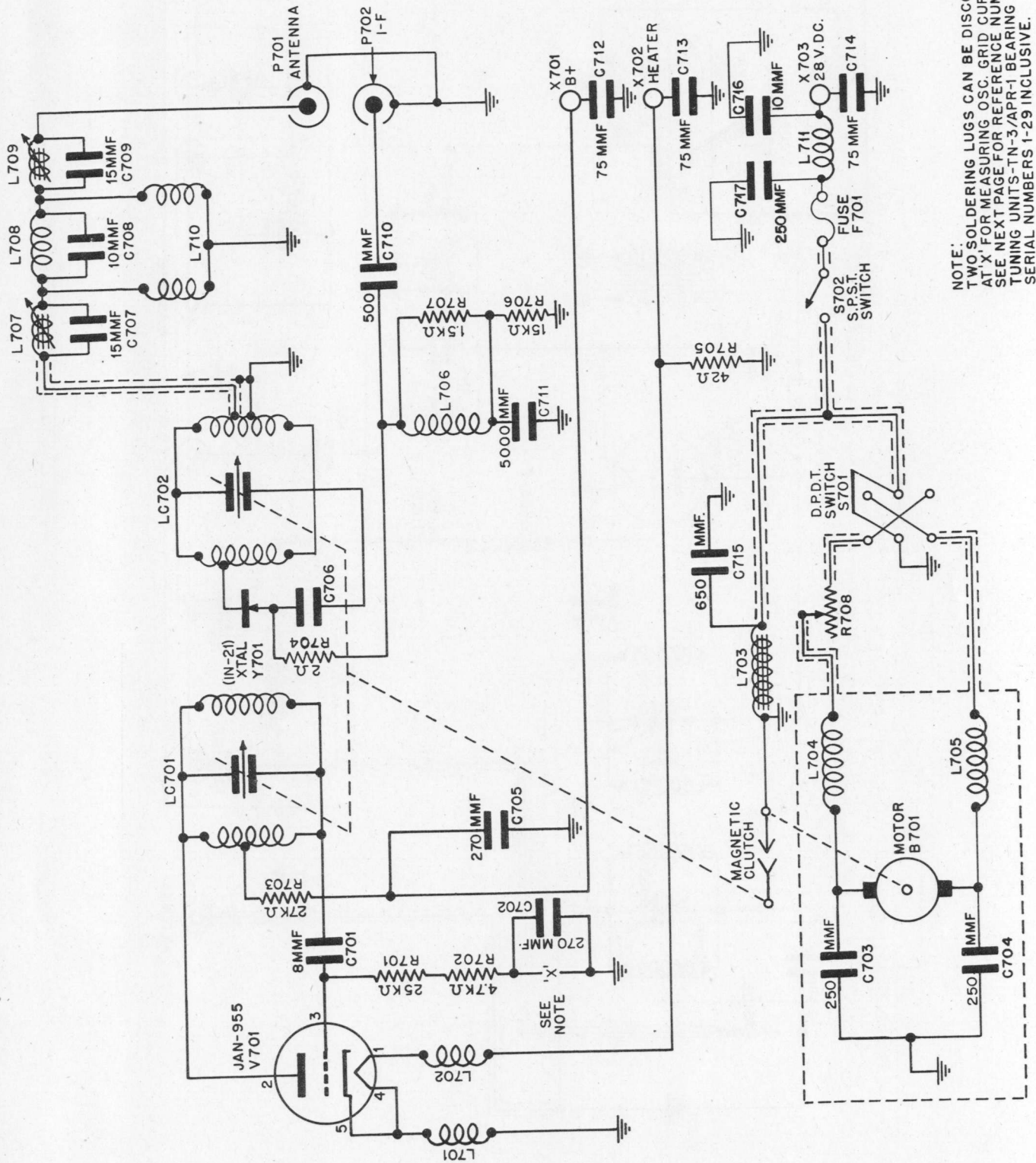

Figure 8-9. Tuning Unit TN-3B/APR-1, Practical Wiring Diagram.



NOTE:  
 TWO SOLDERING LUGS CAN BE DISCONNECTED  
 AT X FOR MEASURING OSC. GRID CURRENT  
 SEE NEXT PAGE FOR REFERENCE NUMBERS OF  
 TUNING UNITS-TN-3/APR-1 BEARING THE  
 SERIAL NUMBERS 1-29 INCLUSIVE.

Figure 8-10. Tuning Unit TN-3B/APR-1, Schematic Diagram.

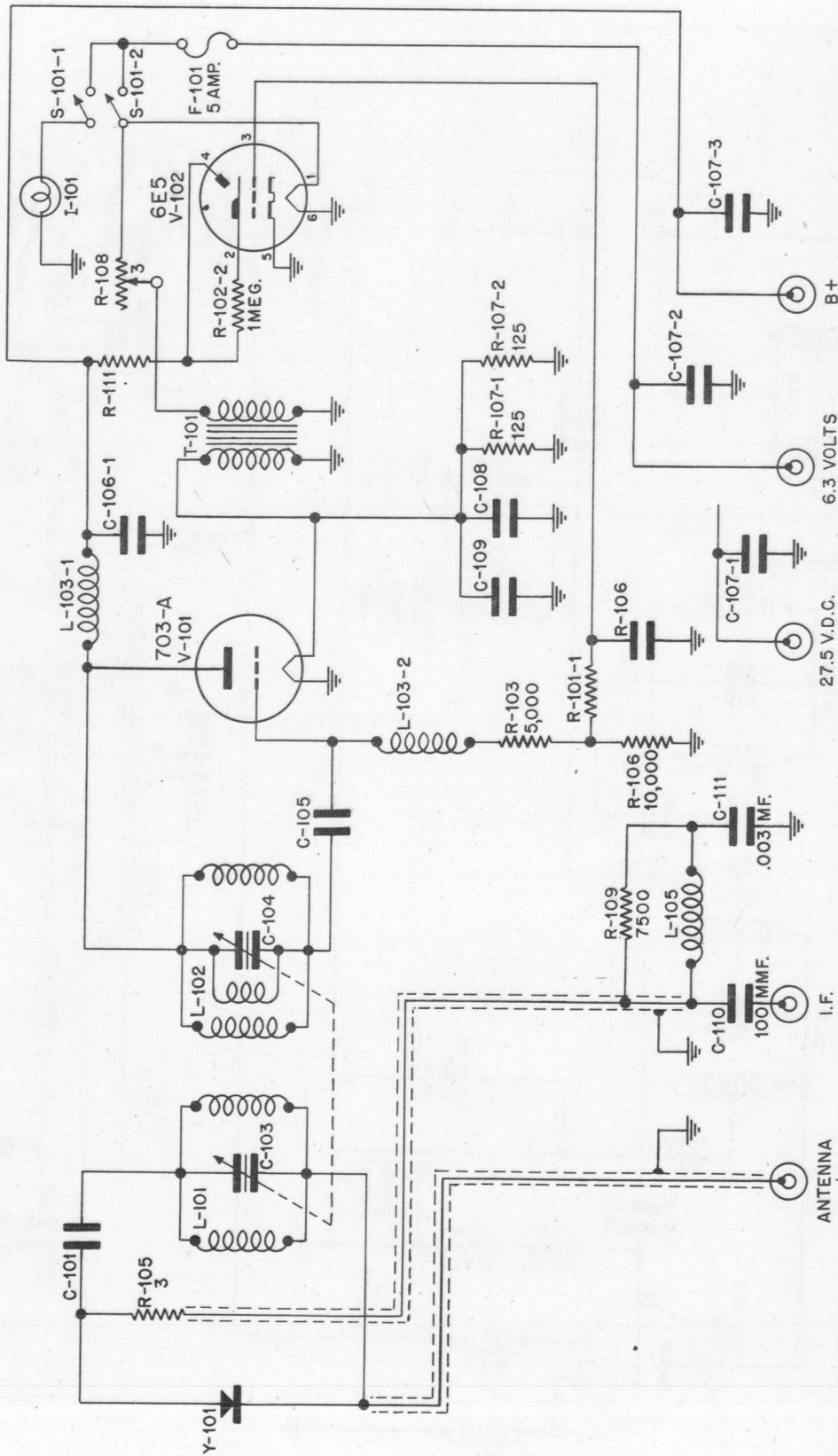
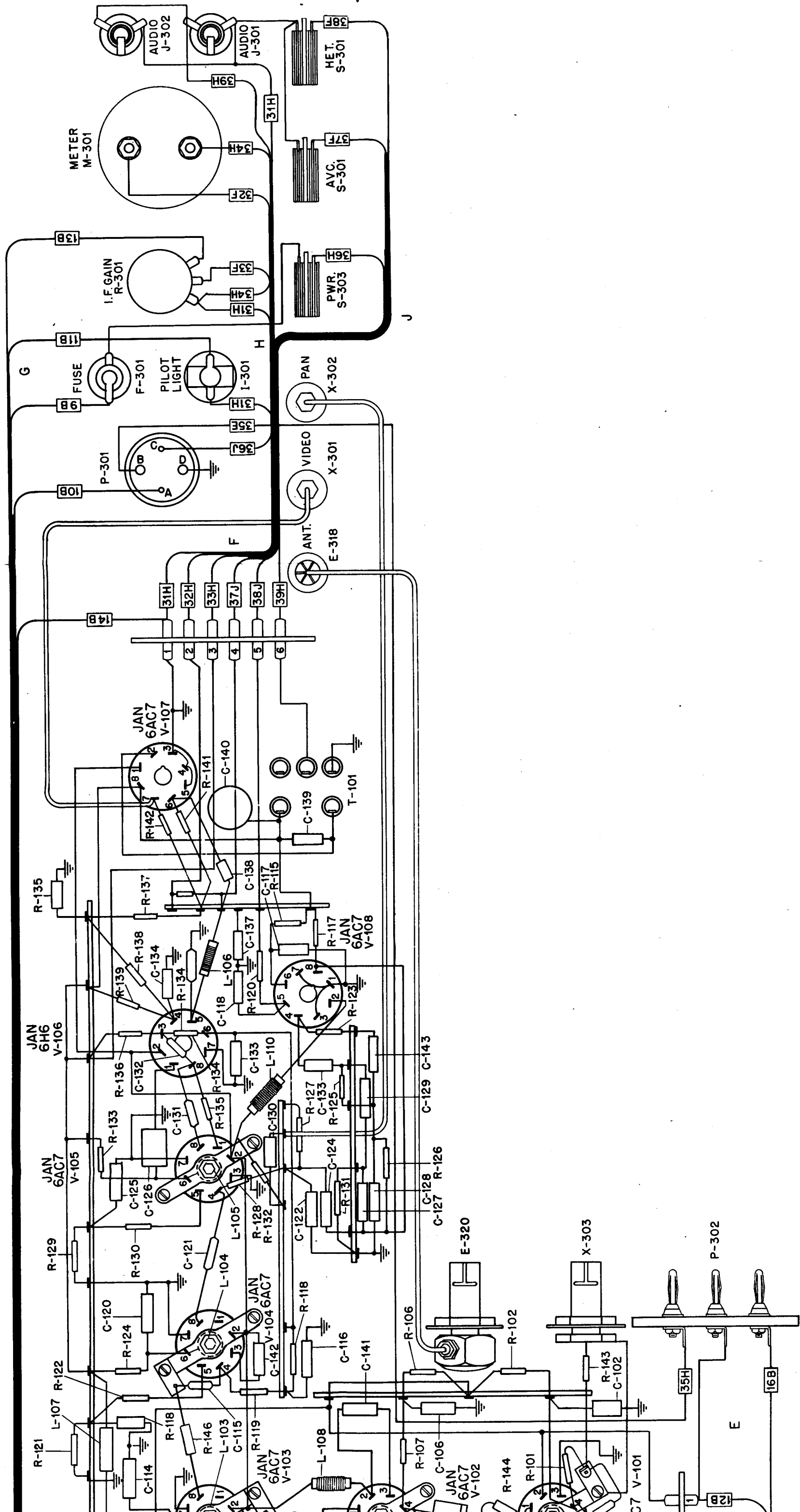

Figure 8-11. Tuning Unit TN-4/APR-1, Schematic.



RESTRICTED  
AN-16-30APR-1-3  
NAVSHIPS 900, 483A



Figur 8-12. Radio Receiving Equipment AN/APR-1 and AN/SPR-1, Practical Wiring Diagram.

RESTRICTED

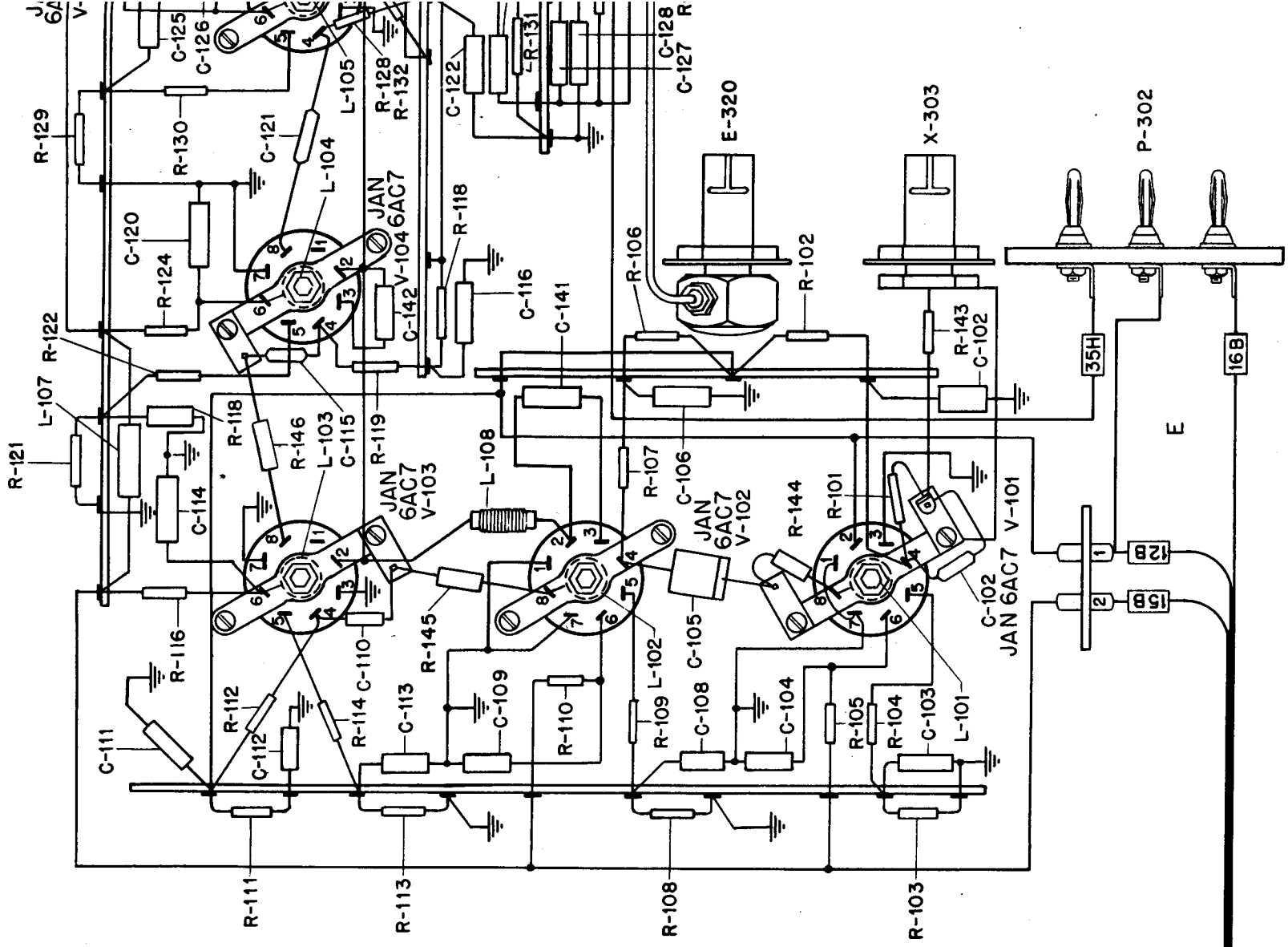
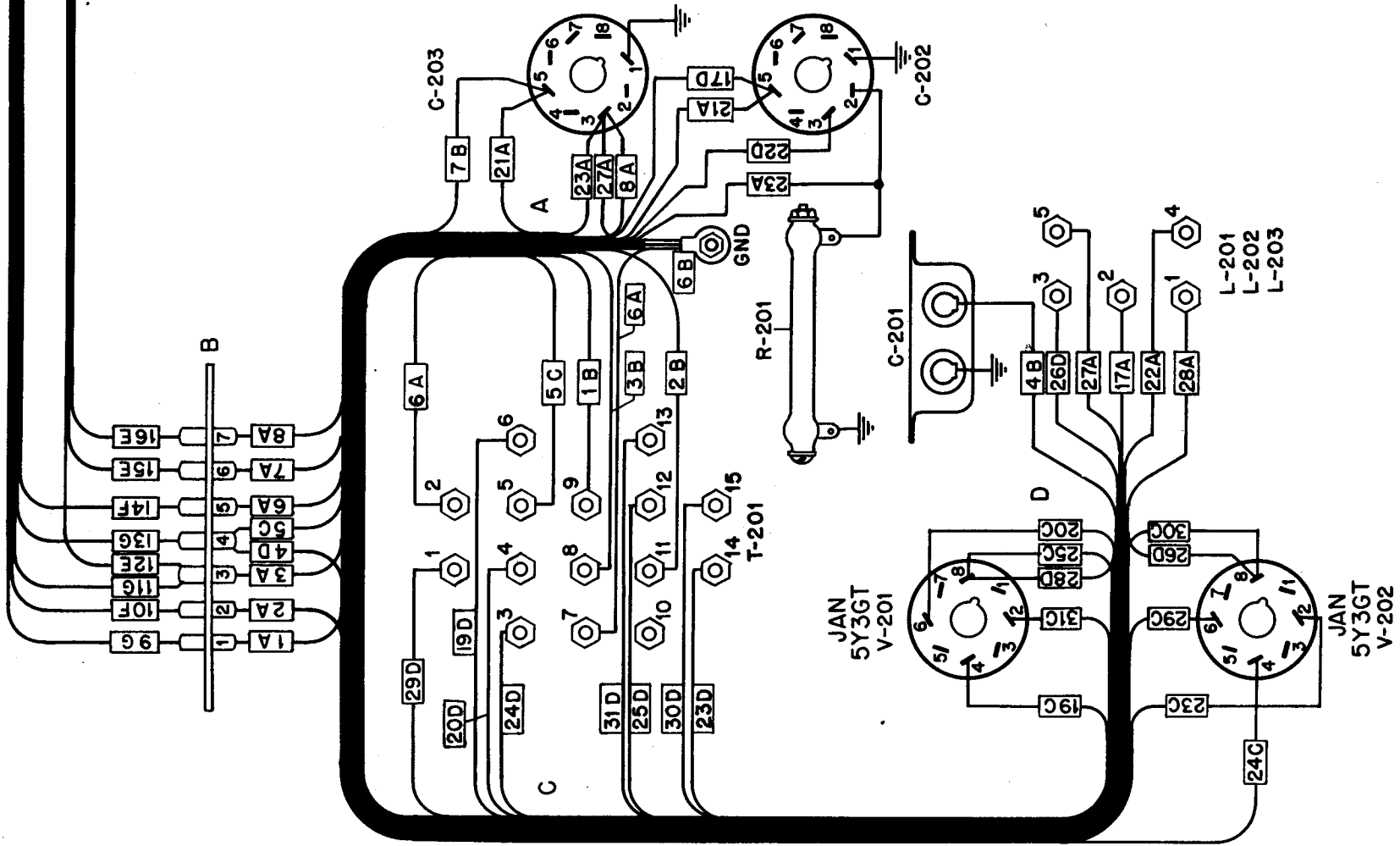

RESTRICTED  
AN-16-30APR-1-3  
NAVSHIPS 900, 483A

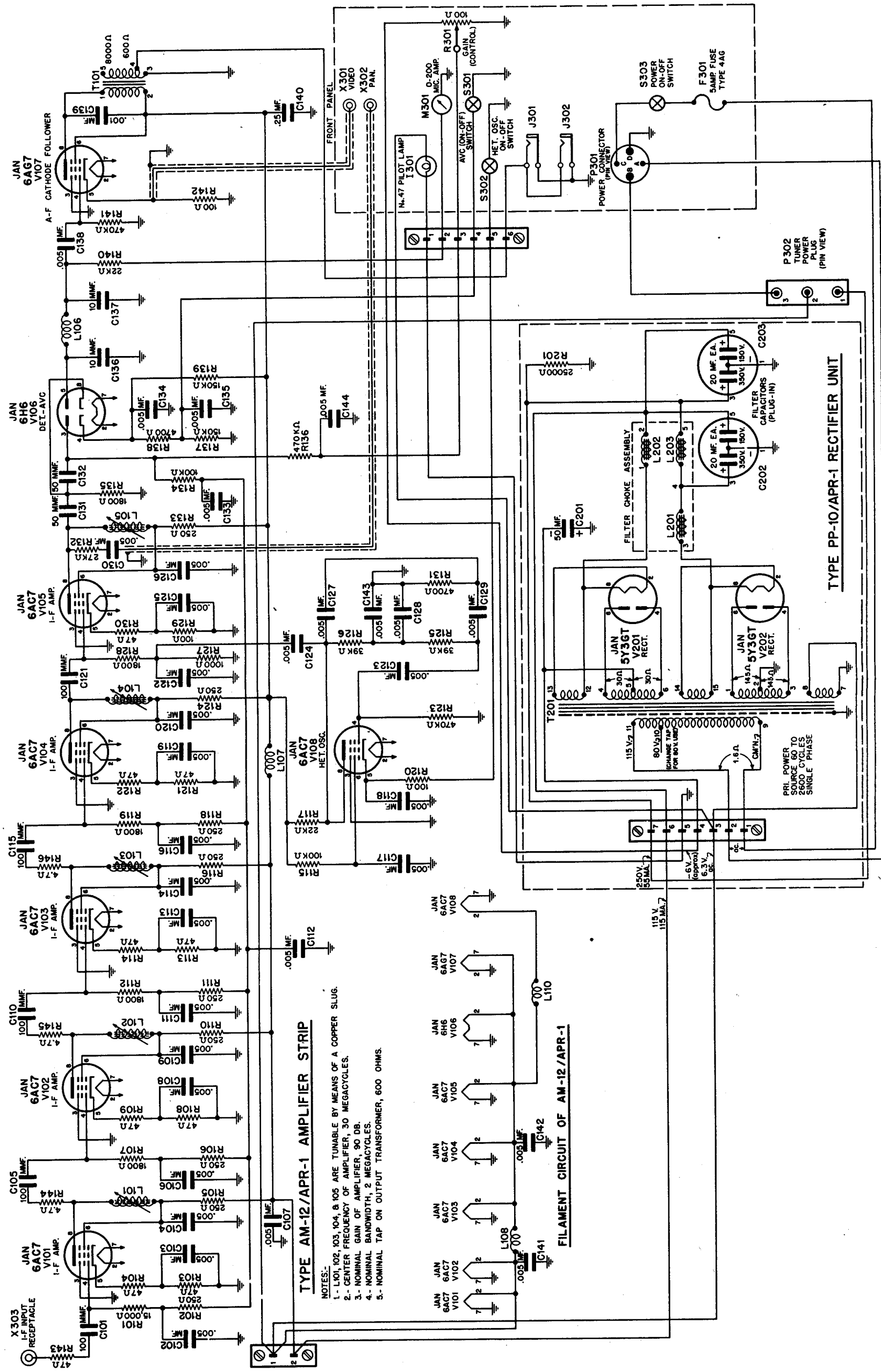

Figur 8-13. Radi Receiving Equipm nt AN/(A)PR-1 and AN/SPR-1, Schematic Diagram.

RESTRICTED

~~RESTRICTED~~

FOR OFFICIAL USE ONLY

AN 08-30APR4-3

HANDBOOK OF  
MAINTENANCE INSTRUCTIONS  
*for*  
RECEIVING EQUIPMENT  
AN/APR-4

*Published under joint authority of the United States War and Navy  
Departments and the Air Council of the United Kingdom*

~~RESTRICTED~~

PROCESS LITHO - DETROIT 8/24/45 3,000

**5 DECEMBER 1944**  
REVISED 25 JUNE 1945

SECURITY NOTICE

FOR U. S. PERSONNEL: This document contains information affecting the national defense of the United States within the meaning of the Espionage Act, 50 U.S.C., 31 and 32, as amended. Its transmission or the revelation of its contents in any manner to an unauthorized person is prohibited by law. (AR 380-5) (ARTS 75½ & 76, U.S.N. REGS-1920.)

The information contained in restricted documents and the essential characteristics of restricted materiel will not be communicated to the public or to the press, but may be given to any

person known to be in the service of the United States and to persons of undoubted loyalty and discretion who are cooperating in Government work.

FOR BRITISH PERSONNEL: For Official Use Only—Not to be communicated to anyone outside His Majesty's Service. Not to be published. The information given in this document is not to be communicated, either directly or indirectly, to the press or to any person not holding an official position in His Majesty's Service.

LIST OF REVISED PAGES ISSUED

NOTE: A heavy black vertical line, to the left of the text on revised pages, indicates the extent of the revision. This line is omitted where more than 50 percent of the page is revised.

<i>Page No.</i>	<i>Date of Latest Revision</i>
7-25—7-26 .....	25 June 1945

AAF

ADDITIONAL COPIES OF THIS PUBLICATION MAY BE OBTAINED AS FOLLOWS:

AAF ACTIVITIES.—In accordance with T. O. No. 00-5-2, base Air Inspectors, Technical will submit requisitions (AAF Form 104B) to:

Commanding General  
Fairfield Air Technical Service Command  
Patterson Field, Ohio  
Attn: Publications Distribution Branch

NAVY ACTIVITIES.—Submit requests to Chief, BuAer, Navy Department, Washington, D. C., Attention: Publications Branch on order form NAVAER-140. For complete listing of available material and details of distribution see Naval Aeronautic Publications Index, NavAer 00-500.

BRITISH ACTIVITIES.—Submit requirements on Form 294A, in duplicate, to the Air Publications and Forms Store, New College, Leadhall Lane, Harrogate, Yorkshire, England.

JUMPERS

To	Description
V-101-4.8	Bare No. 20
L-104	Bare No. 20
Gnd.	Bare No. 18
L-108-4	Bare No. 20
V-101-4.3	Bare No. 18
V-101-4.7	Bare No. 18
Gnd.	Bare No. 20
T-101-3.6	Bare No. 20
Gnd.	Bare No. 18
Gnd.	Bare No. 18
T-101-3.2	Bare No. 20
R-102-7	Yel. Grn. No. 22
R-102-5	Yel. Grn. No. 22
Gnd.	Bare No. 20
V-101-3.3	Bare No. 18
V-101-3.7	Bare No. 18
T-101-2.6	Bare No. 20
Gnd.	Bare No. 18
L-108-3	Bare No. 20
Gnd.	Bare No. 18
T-101-2.2	Bare No. 20
V-101-2.3	Bare No. 18
V-101-2.7	Bare No. 18
Gnd.	Bare No. 18
T-101-1.6	Bare No. 20
R-102-3	Yel. Grn. No. 22
Gnd.	Bare No. 18
T-101-2	Bare No. 20
V-101-1.3	Bare No. 18
V-101-1.3	Bare No. 18
L-108-1	Bare No. 20
Gnd.	Bare No. 18
L-108-2	Bare No. 18
TB-2	Bare No. 20
C-105-C	Red No. 22
V-101-7.6	Red Blk. Tr. No. 22
Gnd.	Bare No. 20
C-106-6	Bare No. 20
C-108-2	Bare No. 20
Gnd.	Bare No. 20
R-120-4	Bare No. 20
R-129-3	Bare No. 20
C-106-5	Bare No. 20
R-119-3	Bare No. 20
C-108-4	Bare No. 20
V-101-7.8	Bare No. 20
V-101-7.5	Bare No. 20
V-101-7.1	Bare No. 20
R-129-1	Bare No. 20
T-101-2.5	Yel. Grn. No. 22
R-127-2	Bare No. 20
Gnd.	Bare No. 20
Gnd.	Bare No. 20
Gnd.	Bare No. 20
V-101-2	Bare No. 20
V-103-2	Bare No. 20
V-101-7.2	Bare No. 20
V-101-7.3	Bare No. 20
TB-3	Bare No. 20
L-104	Bare No. 20
S-101-12	Bare No. 22
S-101-11	Bare No. 22
S-101-10	Bare No. 22
S-101-9	Bare No. 22
S-101-8	Bare No. 22
S-101-7	Bare No. 22
S-101-5	Bare No. 22
S-101-4	Bare No. 22
S-101-3	Bare No. 22
S-101-2	Bare No. 22
T-103-1	Black No. 20

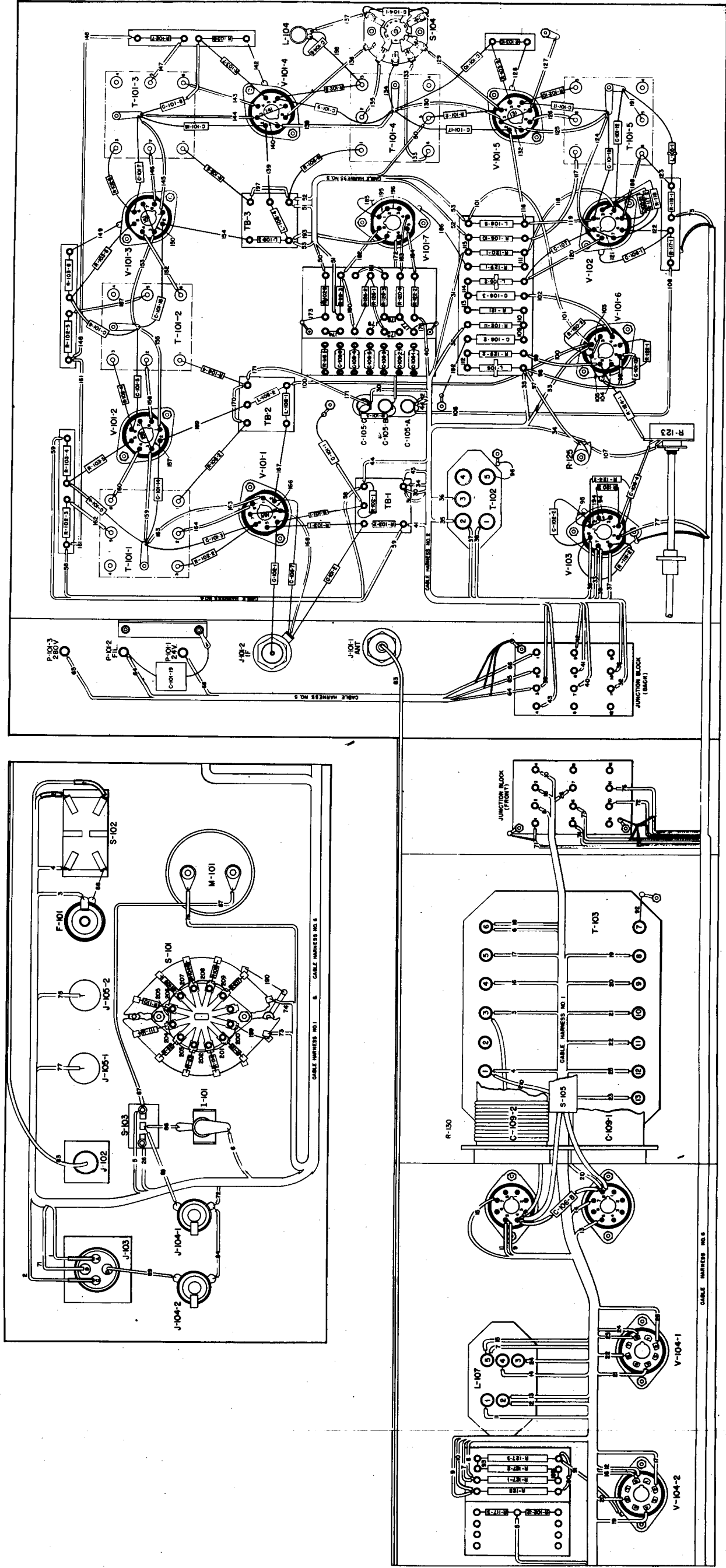

Figur 7-28. R e c i v i n g E q u i p m e n t A N / A P R - 4 - C n n e c t i o n D i a g r a m

RESTRICTED

Revised 25 June 1945

RESTRICTED

7-25-7-26

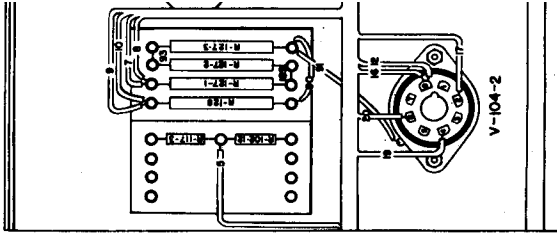

CABLE HARNESS NO. 5 (C nt)

Wire No.	From	To	Description
67	J-103-B	JB-1	White No. 20
68	J-104-1	JB-6	White No. 20
69	S-101	JB-5	White No. 20
70	S-105-2	R-119-1	White No. 20
	M-101	JB-11	White No. 20
	J-105-1	V-103-5	CABLE

CABLE HARNESS NO. 6

Wire No.	From	To	Description
71	J-103-B	JB-1	White No. 20
72	J-104-1	JB-6	White No. 20
73	S-101	JB-5	White No. 20
74	S-105-2	R-119-1	White No. 20
75	M-101	JB-11	White No. 20
76	J-105-1	V-103-5	CABLE

CABLE HARNESS NO. 1

Wire No.	From	To	Description
1	S-102	J-103-A	Brown No. 16
2	S-102	J-103-C	Bkn. Blk. Tr. No. 16
3	F-101	T-103-3	Blk. Wh. Tr. No. 20
4	S-102	T-103-1	Black. No. 20
5	S-103	R-102-12	Green No. 22
6	L-101	T-117-3	Yellow No. 22
7	R-127-1	L-103-6	Red Blue No. 22
8	R-127-1	L-107-5	Red Blue No. 22
9	R-128	JB-2	Red No. 22
10	R-128	JB-4	Red No. 22
11	L-107-1	C-109-2.5	Red No. 22
12	V-104-2.8	L-107.2	Red No. 22
13	V-104-2.8	L-107.2	Red No. 22
14	C-109-1.7	L-107.4	Red Blue No. 22
15	C-109-2.7	L-107.5	Red Blue No. 22
16	V-104-2.8	T-103.4	Brown No. 22
17	V-104-2.2	T-103.5	Brown No. 22
18	JB-3	T-103.6	Yellow No. 20
19	V-104-2.4	T-106.8	Red Green No. 22
20	V-104-2.6	T-103.9	Red Green No. 22
21	V-104-1.4	T-103.10	Red Slate No. 22
22	V-104-1.6	T-103.11	Red Slate No. 22
23	V-104-1.8	T-103.13	Brown No. 22
24	V-104-1.8	L-107.3	Red Blue No. 22
25	V-104-1.2	T-103.12	Brown No. 22
26	S-103	JB-7	Slate No. 22

CABLE HARNESS NO. 2

Wire No.	From	To	Description
30	TB-1	C-105-C	Red No. 22
31	TB-1	R-120-1	Red No. 22
32	JB-11	R-102-11	Green No. 22
33	V-103-7	V-106-6.2	Yellow No. 20
34	TB-1	R-125	Red No. 22
35	T-102.2	L-106	Red No. 22
36	JB-10	T-102.3	Red No. 22
37	V-103.6	T-102.2	Red Black No. 22
38	V-103.8	T-102.1	Red No. 22
39	JB-3	V-103.7	Blue No. 22
40	JB-7	R-122.2	Yellow No. 20
41	JB-6	R-103-2	Slate No. 22
42	JB-5	C-105-A	Red Brn No. 22
43	JB-4	TB-1	Yel. Grn. No. 22
44	R-102-1	C-105-A	Red No. 22
45			Yel. Grn. No. 22

CABLE HARNESS NO. 3

Wire No.	From	To	Description
50	R-102-9	T-101-4.5	Slate No. 22
51	R-119-3	TB-3	Red No. 22
52	TB-3	R-106-10	Red No. 22
53	L-108-3		
54	L-108-4	L-108-5	Yellow No. 20

CABLE HARNESS NO. 4

Wire No.	From	To	Description
58	R-102-3	R-102-1	Yel. Grn. No. 22
59	R-103-4	R-103-2	Red Brn. No. 22

CABLE HARNESS NO. 5

Wire No.	From	To	Description
64	JB-3	P-101-2	White No. 20
65	JB-2	P-101-3	White No. 20
66	JB-1	P-101-1	White No. 20

JUMPERS

Wire No.	From	To	Description
136	S-104	V-101-4.8	Bare No. 20
137	S-104	L-104	Bare No. 20
138	V-101-4.1	Gnd.	Bare No. 18
139	V-101-4.2	L-108-4	Bare No. 20
140	V-101-4.3	V-101-4.7	Bare No. 18
141	V-101-4.3	Gnd.	Bare No. 20
142	R-103-8	T-101-3.6	Bare No. 18
143	V-101-4.4	Gnd.	Bare No. 20
144	V-101-4.3	Gnd.	Bare No. 18
145	V-101-3.1	Gnd.	Bare No. 20
146	V-101-3.8	T-101-3.2	Bare No. 18
147	T-101-3.5	R-102-7	Yel. Grn. No. 22
148	R-102-7	R-102-5	Yel. Grn. No. 22
149	R-103-6	Gnd.	Bare No. 20
150	V-101-3.1	V-101-3.3	Bare No. 18
151	V-101-3.3	V-101-3.7	Bare No. 18
152	V-101-3.4	T-101-2.6	Bare No. 20
153	V-101-3.3	Gnd.	Bare No. 18
154	V-101-3.2	L-108-3	Bare No. 20
155	V-101-2.1	Gnd.	Bare No. 18
156	V-101-2.8	T-101-2.2	Bare No. 20
157	V-101-2.1	V-101-2.3	Bare No. 18
158	V-101-2.3	V-101-2.7	Bare No. 18
159	V-101-2.3	Gnd.	Bare No. 18
160	V-101-2.4	T-101-1.6	Bare No. 20
161	R-102-5	R-102-3	Yel. Grn. No. 22
162	V-101-1	Gnd.	Bare No. 18
164	V-101-1.8	T-101-2	Bare No. 20
165	V-101-1.7	V-101-1.3	Bare No. 18
166	V-101-1.1	V-101-1.3	Bare No. 18
167	V-101-1.2	L-108-1	Bare No. 20
168	V-101-1.3	Gnd.	Bare No. 18
169	V-101-2.2	L-108-2	Bare No. 18
170	TB-2	TB-2	Bare No. 20
171	TB-2	C-105-C	Red No. 22
172	C-105-B	V-101-7.6	Red Blk. Tr. No. 22
173	R-102-9	Gnd.	Bare No. 20
174	R-116	C-106-6	Bare No. 20
175	C-108-3	C-108-2	Bare No. 20
176	C-108-1	Gnd.	Bare No. 20
177	C-108-1	R-120-4	Bare No. 20
178	R-120-4	R-129-3	Bare No. 20
179	R-109-4	C-106-5	Bare No. 20
180	C-108-4	R-119-3	Bare No. 20
181	R-129-3	C-108-4	Bare No. 20
182	R-119-3	V-101-7.8	Bare No. 20
184	R-122-2	V-101-7.5	Bare No. 20
185	Gnd.	V-101-7.1	Bare No. 20
186	Gnd.	R-129-1	Bare No. 20
187	R-102-5	T-101-2.5	Yel. Grn. No. 22
188	V-102-5	T-101-5.6	Bare No. 20
189	S-101	R-127-2	Bare No. 20
191	T-101-5.5	Gnd.	Bare No. 20
192	C-106-2	Gnd.	Bare No. 20
193	L-108-3	Gnd.	Bare No. 20
194	L-108-4	V-101-2	Bare No. 20
195	V-101-7.1	V-103-2	Bare No. 20
196	V-101-7.2	V-101-7.2	Bare No. 20
197	R-106-6	V-101-7.3	Bare No. 20
198	T-101-4.3	TB-3	Bare No. 20
199	Wire 73	L-104	Bare No. 20
200	S-101-12	S-101-12	Bare No. 22
201	S-101-11	S-101-11	Bare No. 22
202	S-101-10	S-101-10	Bare No. 22
203	S-101-9	S-101-9	Bare No. 22
204	S-101-8	S-101-8	Bare No. 22
206	S-101-6	S-101-5	Bare No. 22
207	S-101-5	S-101-4	Bare No. 22
208	S-101-4	S-101-3	Bare No. 22
209	S-101-3	S-101-2	Bare No. 22
210	C-109-1.8	T-103-1	Black No. 20