

UNCLASSIFIED

NAVSHIPS 94253

(*Non-Registered*)

TECHNICAL MANUAL
for
ANTENNA
COUPLER GROUP
AN/FRA-49(V)

ELECTRONIC COMMUNICATIONS, INCORPORATED
1501 - 72ND STREET NORTH
ST. PETERSBURG, FLORIDA

DEPARTMENT OF THE NAVY
BUREAU OF SHIPS

UNCLASSIFIED

Contract: NObsr 85264 Approved by BuShips: 4 December 1961

Office of Industrial Manager, USN
Sixth Naval District
P. O. Box 7287
Charleston Heights, S. C.

LIST OF EFFECTIVE PAGES

PAGE NUMBERS	CHANGE IN EFFECT	PAGE NUMBERS	CHANGE IN EFFECT
Title Page	Original	6-0 to 6-26	Original
ii to vii	Original	7-1 to 7-15	Original
1-0 to 1-3	Original	i-1 to i-1	Original
2-0 to 2-4	Original		
3-1	Original		
4-0 to 4-7	Original		
5-0 to 5-7	Original		

TEMPORARY CORRECTION T-2 TO TECHNICAL MANUAL FOR ANTENNA
COUPLER GROUP AN/FRA-49(V) NAVSHIPS 94253

This temporary correction reflects changes resulting from the manual review by the Bureau of Ships. This correction will be applicable to all Antenna Coupler Group AN/FRA-49(V) final manuals shipped after the above date.

Make the following pen and ink corrections or reference to this page. Insert this temporary correction in the technical manual immediately under the front cover and on top of previous temporary corrections.

<u>PAGE NO</u>	<u>CHANGE IN EFFECT</u>	<u>PARA</u>	<u>LINE</u>	<u>ACTION</u>
1-1	Original	1-2	7	Delete the phrase "of two to 15 mc." and add "which is determined by the particular antenna couplers in the equipment cabinet."
1-1				Delete the sentence "This permits simultaneous transmission of AM signals (SSB or DSB)."
1-1	Original	1-2	29	Add the following sentence. "The interconnecting cables used between the associated equipments and the antenna coupler group are not furnished."
1-1	Original	1-4h	19	Delete the word "Isolation" and substitute the word "Separation".
1-3	Original	1-5c	1	Delete the sentence "There are no relevant equipment similarities." and substitute the following sentence: "CU-480(XN-1)/U is similar equipment."
2-3	Original	2-4d(5)	3	Delete the phrase "the TUNING control to obtain a null on the meter " and substitute
4-0	Original	4-1a	9	Delete the phrase "for the simultaneous transmission of three amplitude modulated or single-side-band messages." and substitute the word "simultaneously."
4-0	Original	4-1b	10	Change the capitalization on the word "The" in the last sentence to lower case and precede this with the following phrase:
4-0	Original	4-1b	13	Delete the word "voltage" and substitute "current".

Office of Industrial Manager, USN
Sixth Naval District
P. O. Box 7257
Charleston Heights, S. C.

<u>PAGE NO</u>	<u>CHANGE IN EFFECT</u>	<u>PARA</u>	<u>LINE</u>	<u>ACTION</u>
4-0	Original	4-1b	16	Delete the word "voltage" and substitute "power".
4-0	Original	4-1b	18	Delete the word "voltage" and substitute "power".
4-0	Original	4-2a	8	Delete the word "voltage" and substitute "power".
4-0	Original	4-2a	10	Delete the word "voltage" and substitute "power".
4-5/4-6 6-5	Original	6-4	23	Precede the first sentence in the CAUTION instructions with the follow- 
6-14	Original	6-6	1	Precede the first sentence in the CAUTION instructions with the following sentence: "Some parts of the antenna couplers are exposed to RF voltages of approximately 55,000 V which create a corona hazard."
6-14	Original	TABLE 6-1	Bottom	Delete the number "106" in the REQUIRED SETTING column and substitute the number "140".

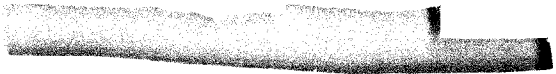
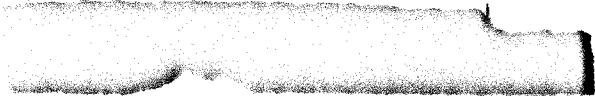

TEMPORARY CORRECTION T-1 TO TECHNICAL MANUAL FOR ANTENNA
COUPLER GROUP AN/FRA-49(V) NAVSHIPS 94253

This temporary correction reflects procedural step changes required to facilitate initial installation of this equipment. This correction will be applicable to all Antenna Coupler Group AN/FRA-49(V) equipments shipped after the above date.

Make the following pen and ink corrections or reference to this page. Insert this temporary correction in the technical manual immediately after the front cover.

<u>PAGE NO</u>	<u>CHANGE IN EFFECT</u>	<u>PARA</u>	<u>LINE</u>	<u>ACTION</u>
2-0	Original	2-3d	3	Delete period and add "except that the antenna coupler will be received partly assembled. Proceed as follows: (1) Remove the hardware that attaches the gear housing to the drum. (2) Lift off gear assembly. (3) Remove the split connectors and the mounting clamp. "
2-0	Original	2-3c	3	Delete period and add "except as follows: (1) remove hardware from the drive plates on front panel. (2) Remove pick-up loop clamping blocks and loosen the bolts which hold the yokes of the upper trundle wheels. "
6-14	Original	6-6d(4)	2	Delete period and add "and reassemble the gear housing assembly to the antenna coupler housing. "
6-14	Original	6-6d(8)	4	Add "Pins will be at right angles to each other. "
6-17	Original	6-6d(14)	6	Insert after period "The trundle wheel brackets may be adjusted to achieve alignment. "
6-17	Original	6-6d(16)	8	Add "Then connect the RF pick-up loop to the junction box. "

Office of Industrial Manager, USN
Sixth Naval District
P. O. Box 7287





DEPARTMENT OF THE NAVY
BUREAU OF SHIPS
WASHINGTON 25, D. C.

IN REPLY REFER TO
Code 242-100

From: Chief, Bureau of Ships
To: All Activities concerned with the Installation, Operation,
and Maintenance of the Subject Equipment

Subj: Technical Manual for Antenna Coupler Group AN/FRA-49(V),
NAVSHIPS 94253

1. This is the Technical Manual for the subject equipment and is in effect upon receipt.
2. When superseded by a later edition, this publication shall be destroyed.
3. Extracts from this publication may be made to facilitate the preparation of other Department of Defense publications.
4. Errors found in this publication (other than obvious typographical errors), which have not been corrected by means of Temporary Corrections or Permanent Changes should be reported. Such report should include the complete title of the publication and the publication number (short title); identify the page and line or figure and location of the error; and be forwarded to the Publications Section of the Bureau of Ships.
5. All Navy requests for Bureau of Ships electronic publications should be directed to the Naval Supply Depot, 5801 Tabor Avenue, Philadelphia, Pennsylvania.

R. K. JAMES
Chief of Bureau

RECORD OF CORRECTIONS MADE

CHANGE NO.	DATE	FIELD CHANGE NO.	SIGNATURE

TABLE OF CONTENTS

SECTION 1 - GENERAL INFORMATION		SECTION 5 - TROUBLE-SHOOTING			
Paragraph	Page	Paragraph	Page		
1-1.	Introduction	1-1	5-1.	General	5-0
1-2.	General Description	1-1	5-2.	Test Equipment and Special Tools . .	5-0
1-3.	Factory and Field Changes	1-1	5-3.	Overall Trouble-Shooting	5-0
1-4.	Quick Reference Data	1-1	5-4.	Functional Section Trouble-Shooting .	5-1
1-5.	Equipment Lists	1-2	5-5.	Typical Troubles	5-2
			5-6.	Location of Parts	5-2
SECTION 2 - INSTALLATION		SECTION 6 - SERVICE AND REPAIR			
2-1.	Unpacking and Handling	2-0	6-1.	Failure Report	6-0
2-2.	Site Selection and Power Requirements	2-0	6-2.	Tuning and Adjustment	6-0
2-3.	Installation Procedures	2-0	6-3.	Emergency Operation	6-0
2-4.	Inspection and Adjustments	2-3	6-4.	Preventive Maintenance of the Antenna Coupler Group	6-5
2-5.	Interference Reduction	2-4	6-5.	Removal of Parts	6-5
2-6.	Preparation for Reshipment	2-4	6-6.	Replacement and Reassembly of Parts	6-14
			6-7.	Adjustments	6-17
			6-8.	Wiring and Schematic Diagrams . . .	6-17
SECTION 3 - OPERATOR'S SECTION		SECTION 7 - PARTS LIST			
3-1.	Operating Procedures	3-1	7-1.	Introduction	7-1
3-2.	Emergency Operation	3-1	7-2.	Maintenance Parts List	7-1
			7-3.	List of Manufacturers	7-1
			7-4.	Stock Number Identification	7-1
SECTION 4 - PRINCIPLES OF OPERATION					
4-1.	Overall Functional Description	4-0			
4-2.	Functional Sections	4-0			

LIST OF ILLUSTRATIONS

SECTION 1 - GENERAL INFORMATION

Figure	Page
1-1. Antenna Coupler Group AN/FRA-49(V)	1-0

SECTION 2 - INSTALLATION

2-1. Antenna Coupler Group AN/FRA-49(V), Outline Drawing	2-1
---	-----

SECTION 4 - PRINCIPLES OF OPERATION

4-1. Antenna Coupler Group AN/FRA-49(V), Overall Functional Block Diagram	4-1
4-2. Typical Directional Coupler and An- tenna Coupler (Channel 1), Simpli- fied Schematic Diagram	4-3
4-3. Typical RF INDICATOR Meter and Protection Circuit (Channel 1), Simplified Schematic Diagram	4-5

SECTION 5 - TROUBLE-SHOOTING

5-1. Electrical Equipment Cabinet CY-3409/FRA-49(V), Inside Front Panel	5-3
5-2. Electrical Equipment Cabinet CY-3409/FRA-49(V), Right Side View (Sides Removed)	5-4
5-3. Electrical Equipment Cabinet CY-3409/FRA-49(V), Rear Panel	5-5

SECTION 6 - SERVICE AND REPAIR

6-1. Antenna Coupler Group AN/FRA-49(V), Front Panel View	6-1
6-2. Antenna Coupler Group AN/FRA-49(V), Rear Panel Connectors	6-2
6-3. Tuning Graph, Antenna Coupler CU-998/FRA-49(V) (2 to 6 mc).	6-3

6-4. Coupling Graph, Antenna Coupler CU-998/FRA-49(V) (2 to 6 mc)	6-4
6-5. Typical Bandpass Response Curve for Antenna Coupler Group	6-6
6-6. Typical Channel Isolation Factors for Antenna Coupler Group	6-7
6-7. Typical Efficiency Factors for Antenna Coupler Group	6-7
6-8. Electrical Equipment Cabinet CY-3409/FRA-49(V), Inside Front Panel (tuners removed)	6-8
6-9. Electrical Equipment Cabinet CY-3409/FRA-49(V), Inside Rear Panel (tuners removed)	6-9
6-10. Electrical Equipment Cabinet CY-3409/FRA-49(V), Left Rear Oblique View	6-10
6-11. Antenna Coupler, Small Capacitor Removed	6-11
6-12. Electrical Equipment Cabinet CY-3409/FRA-49(V), Left Front Oblique View	6-12
6-13. Antenna Coupler, Gear Housing Assembly	6-13
6-14. Coil Subassembly, With Pickup Loop	6-15
6-15. Coil Subassembly, Pickup Loop Removed	6-16
6-16. Antenna Coupler Tuner Housing Drum	6-18
6-17. Antenna Coupler Group AN/FRA-49(V), Wiring Diagram (2 sheets)	6-19
6-18. Antenna Coupler Group AN/FRA-49(V), Schematic Diagram	6-23
6-19. Tuning Graph, Antenna Coupler CU-999/FRA-49(V) (5-15 mc)	6-25
6-20. Coupling Graph, Antenna Coupler CU-999/FRA-49(V) (5-15 mc)	6-26

LIST OF TABLES

SECTION 1 - GENERAL INFORMATION		SECTION 5 - TROUBLE-SHOOTING (cont)	
Table	Page	Table	Page
1-1. Equipment Supplied	1-2	5-3. Antenna Coupler Group AN/FRA-49(V), RF INDICATOR Meter Circuit, Func- tional Section Trouble-Shooting Chart	5-2
1-2. Shipping Data	1-2	5-4. Antenna Coupler Group AN/FRA-49(V), Protection Circuit, Functional Sec- tion Trouble-Shooting Chart	5-6
1-3. Electron Tube Complement	1-3	5-5. Antenna Coupler Group AN/FRA-49(V), Directional Coupler and Antenna Coupler, Functional Section Trouble- Shooting Chart	5-6
SECTION 2 - INSTALLATION		5-6. Antenna Coupler Group AN/FRA-49(V), Blower Circuits, Functional Section Trouble-Shooting Chart	5-7
2-1. Antenna Coupler Group AN/FRA-49(V), Transmitter Cable Fabrication and Connection (Three Required)	2-2	5-7. Antenna Coupler Group AN/FRA-49(V), Typical Troubles	5-7
2-2. Antenna Coupler Group AN/FRA-49(V), Antenna Cable Fabrication (One Required)	2-2	SECTION 6 - SERVICE AND REPAIR	
2-3. Antenna Coupler Group AN/FRA-49(V) Remote Control Cable Fabrication (Three Required)	2-2	6-1. Tuning Capacitor Installation Settings .	6-14
2-4. Antenna Coupler Group AN/FRA-49(V), Power Cable Fabrication (One Required)	2-3	SECTION 7 - PARTS LIST	
SECTION 5 - TROUBLE-SHOOTING		7-1. Antenna Coupler Group AN/FRA-49(V), Maintenance Parts List	7-1
5-1. Test Equipment	5-0	7-2. List of Manufacturers	7-14
5-2. Antenna Coupler Group AN/FRA-49(V), System Trouble-Shooting Chart	5-1		

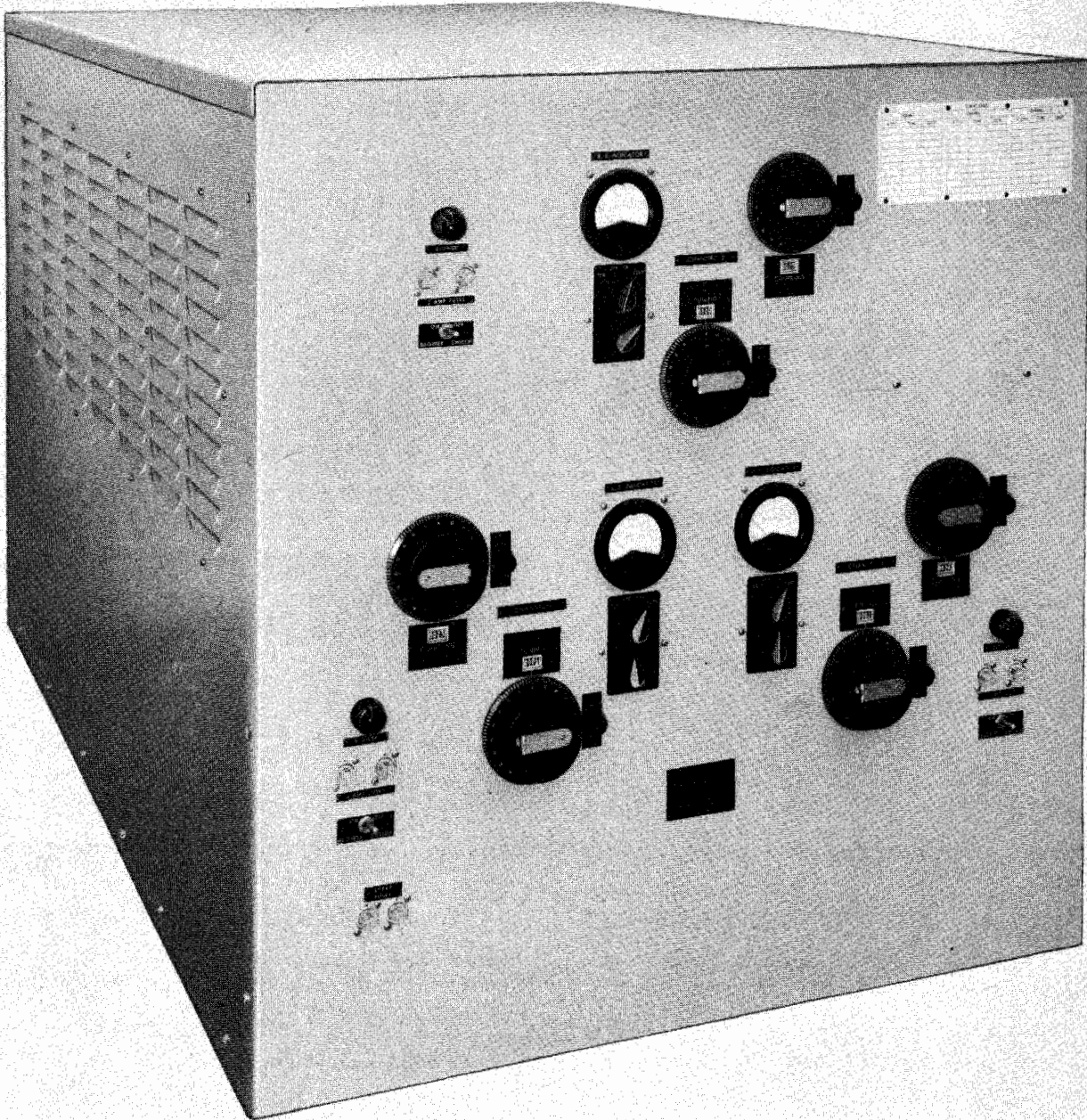

Figure 1-1. Antenna Coupler Group AN/FRA-49(V)

SECTION 1
GENERAL INFORMATION

1-1. INTRODUCTION.

This manual provides complete information for the installation, operation, and repair of Antenna Coupler Group AN/FRA-49(V). Principles of operation are explained in sufficient detail, and trouble-shooting data is so arranged, that a minimum of down time may be achieved.

1-2. GENERAL DESCRIPTION.

Antenna Coupler Group AN/FRA-49(V) is designed for use at U. S. Navy shore stations and is not to be exposed to the weather. The equipment is designed for operation in the temperature range of zero to 50°C (Class 4) into an antenna that presents an impedance variation of three to one or less over the frequency range of two to 15 mc. *which is determined by the equipment cabinet.*
The Antenna coupler group (figure 1-1) consists of three antenna couplers that may be any desired combination of Antenna Coupler CU-998/FRA-49(V) and Antenna Coupler CU-999/FRA-49(V) housed in an Electrical Equipment Cabinet CY-3409/FRA-49(V). Circulating air is drawn from behind the cabinet by means of three individually controlled electric fans to dissipate heat.

The antenna coupler group is an accessory unit that couples the output power of one to three radio transmitters to a common broadband antenna. ~~This permits simultaneous transmission of AM signals (SSB or DSB).~~ Antenna Coupler CU-998/FRA-49(V) is used when transmitting in the two to six megacycle frequency range and Antenna Coupler CU-999/FRA-49(V) is used when transmitting in the five to 15 megacycle frequency range. To prevent degradation of performance a guardband must be established between any two carriers that is at least equal to 10 per cent of the lower carrier frequency. Paragraph 1-4 summarizes the principal features of the antenna coupler group. *See T-2*

Antenna Coupler CU-998/FRA-49(V) or Antenna Coupler CU-999/FRA-49(V) consists of a single channel with its output series connected to the antenna. A directional coupler in the channel samples the r-f voltages (forward and reflected). These voltages are rectified and used for monitoring and equipment protection purposes.

NOTE

The directional coupler is referred to as such because it may be connected correctly in only one way. Technically it is a bidirectional device.

A removable r-f tuning unit is the main item of the antenna coupler. It can be tuned through the entire frequency range of the antenna coupler.

1-3. FACTORY AND FIELD CHANGES.

None.

1-4. QUICK REFERENCE DATA.

a. Primary Power Input (Fans and overload circuits)	115 vac 50/60 cps ±10 per cent 108 Watts
b. Frequency Range	
(1) Antenna Coupler CU-998/FRA-49(V)	Two mc to six mc
(2) Antenna Coupler CU-999/FRA-49(V)	Five mc to 15 mc
c. Transmission Efficiency	
(1) Antenna Coupler CU-998/FRA-49(V)	78 per cent
(2) Antenna Coupler CU-999/FRA-49(V)	75 per cent
d. Input Impedance	75 ohms
e. Output Impedance	75 ohms
f. Antenna Impedance Variation	3:1 or less
g. Maximum Input Power (R-f) (Per channel)	Three kw carrier level, 100 per cent AM DSB or 10 kw Peak-Envelope Power SSB
h. Channel ^{Separation} Isolation (Minimum frequency separation between two channels)	10 per cent of lower channel <i>T-2</i>
i. Adjacent Channel Atten	27 db
j. Temperature Range	0° to 50° C (32° F to 122° F)

1-5. EQUIPMENT LISTS.

a. EQUIPMENT SUPPLIED. - All equipment supplied is listed in table 1-1, following.

TABLE 1-1. EQUIPMENT SUPPLIED

QUAN. PER EQUIP.	NOMENCLATURE		*OVERALL DIMENSIONS			*VOLUME	*WEIGHT
	NAME	DESIGNATION	HEIGHT	WIDTH	DEPTH		
1	Antenna Coupler Group	AN/FRA-49(V)	39-1/2	36-3/16	62-1/2	52	630
1	Connector	P1**					
1	Connector	P2					
1	Connector	P3					
1	Connector	P4					
1	Connector	P5					
1	Connector	P7					
1	Connector	P9					
1	Connector	P11					

* Unless specified, dimensions are in inches, volume in cubic feet, and weight in pounds.

** See Parts List.

b. EQUIPMENT SHIPPING DATA. - All necessary shipping data is shown in table 1-2.

TABLE 1-2. SHIPPING DATA

BOX NO.	NOMENCLATURE		*OVERALL DIMENSIONS			*VOLUME	*WEIGHT
	NAME	DESIGNATION	HEIGHT	WIDTH	DEPTH		
1	Antenna Coupler	CU-998/FRA-49(V) or CU-999/FRA-49(V)	21-5/8	22-7/8	49-1/4	14	190
2	Antenna Coupler	CU-998/FRA-49(V) or CU-999/FRA-49(V)	21-5/8	22-7/8	49-1/4	14	190
3	Antenna Coupler	CU-998/FRA-49(V) or CU-999/FRA-49(V)	21-5/8	22-7/8	49-1/4	14	190
4	Capacitors		26-1/2	27	43-1/2	18	118
5	Electrical Equipment Cabinet	CY-3409/FRA-49(V)	41-1/4	40	67-1/4	64	568

* Unless otherwise noted, dimensions are in inches, volume in cubic feet, and weight in pounds (approximate).

7-2
c. EQUIPMENT SIMILARITIES. - ~~There are no relevant equipment similarities.~~ *There are CU-H80 (XN-1)/u is similar equipment.*

d. ELECTRON TUBE COMPLEMENT. - The semiconductor diodes used in Antenna Coupler Group AN/FRA-49(V) are indicated in table 1-3. The diodes associated with the directional couplers are assembled as part of the connectors and are not replaceable items.

TABLE 1-3. ELECTRON TUBE COMPLEMENT

UNIT AND TUBES	1N540	TOTAL
Electrical Chassis - Overload Protective Device	1	1
Total number of each type	1	1

e. VACUUM CAPACITORS. - Removable variable capacitors with vacuum dielectric are supplied with each antenna coupler as follows: *

- (1) Antenna Coupler CU-998/FRA-49(V):
 - (a.) ECI part/dwg. 11-00069-001,
Quan. - 1
 - (b.) ECI part/dwg. 11-00070-001,
Quan. - 4
- (2) Antenna Coupler CU-999/FRA-49(V):
 - (a.) ECI part/dwg. 11-00069-002,
Quan. - 1
 - (b.) ECI part/dwg. 11-00070-002,
Quan. - 3

* Refer to maintenance parts list for additional details.

SECTION 2
INSTALLATION

WARNING

R-f voltages dangerous to life are present in the r-f sections of the antenna coupler group.

Note

The installation procedures for Antenna Coupler CU-998/FRA-49(V) and Antenna Coupler CU-999/FRA-49(V) are identical.

2-1. UNPACKING AND HANDLING.

The coupler is packed in a wooden crate and four wooden boxes. Shipping boxes should be placed as close to the operating site as is practicable and then opened. Remove all enclosed material such as handbooks, cables and hardware, immediately upon the opening of the inner wrappers.

CAUTION

Handle the vacuum capacitors with care in order to prevent breakage of the glass.

Place capacitors in a safe place until ready for installation. The antenna couplers may stand erect with gear housing uppermost. Dispose of other packaging materials to reduce the possibility of personal accident or equipment damage.

2-2. SITE SELECTION AND POWER REQUIREMENTS.

Select a location that is protected from the weather. The ambient temperature range of the unit is 0 C to +50 C (32 to +122 F). Heating to prevent freeze damage to the non-operating equipment is not required. Provide a power source of 115 vac \pm 10 per cent 50/60 cps. The power required by the unit is 108 watts. Provide ventilation for a heat dissipation of approximately 3000 watts under full operating power.

2-3. INSTALLATION PROCEDURES.

Installation consists of four phases:

- a. Electrical equipment cabinet positioning.
- b. Installation of tuning capacitors in the antenna couplers.
- c. Installation of the antenna couplers into the electrical equipment cabinet.
- d. R-f cable fabrication and installation.

The antenna couplers are heavy. At least three men will be required to handle them. A small frame and endless chain pulley will prove useful if one is available.

a. ELECTRICAL EQUIPMENT CABINET POSITIONING. - All dimensions and required clearances for installation are shown in figure 2-1. When

positioning the electrical equipment cabinet make the following additional allowances, selections and adjustments:

- (1) Allow 2-1/2 feet on either side of the electrical equipment cabinet so that sides can be removed for maintenance.
- (2) Allow a minimum of 2-1/2 feet at the rear of the electrical equipment cabinet for cable connections and ventilation.
- (3) Allow a minimum of 2-1/2 feet at the front of the cabinet.
- (4) When available, allow space for maintenance access through the top of the electrical equipment cabinet.
- (5) Select a firm floor or slab to minimize electrical equipment cabinet settling.
- (6) Adjust the four jack-leveling supports to minimize twist of the electrical equipment cabinet structure. Lay the level on the top edge of the front panel and adjust the front jack-leveling supports. Then lay the level on the top edge of the rear panel and adjust the rear jack-leveling supports. Front-to-rear leveling is less important than side-to-side leveling because it has less twisting effect on the electrical equipment structure.

b. TUNING CAPACITOR INSTALLATION.

The procedure for installing the tuning capacitors is the same as the procedure for replacement of tuning capacitors given in Section 6.

c. ANTENNA COUPLER UNIT INSTALLATION. - The procedure for installation of the antenna couplers is the same as the procedure for replacement of antenna couplers given in Section 6.

Note

Because of the simplicity of the equipment, an interconnection diagram is not required. The cable installation procedures describe the interconnections. Additional data is presented in the full schematic diagram.

d. R-F CABLE FABRICATION AND INSTALLATION.

- (1) TRANSMITTER CABLES. - Fabricate three cables as indicated in table 2-1. Connect one end of each cable to one of the three INPUT 75 Ω jacks (CHANNEL 1, CHANNEL 2, CHANNEL 3) at the rear of the electrical equipment cabinet. Connect the other end of each cable to the associated transmitter output.
- (2) ANTENNA CABLE. - Fabricate the antenna cable as indicated in table 2-2. Fasten the coupling half to the OUTPUT 75 Ω jack at the rear of the electrical equipment cabinet using the four mounting bolts provided. Be sure that the center stub of the coupling half is properly engaged in the jack. Connect the other end of the cable to the input jack of the site antenna.
- (3) REMOTE CONTROL CABLES. - Fabricate three cables as indicated in table 2-3. Connect one end of each cable to one of the three REMOTE CONT. BLOWER jacks at the rear of the electrical equipment cabinet. Connect the other end of the cable to the appropriate terminal board of the associated transmitter as follows:

See Fig 2-1

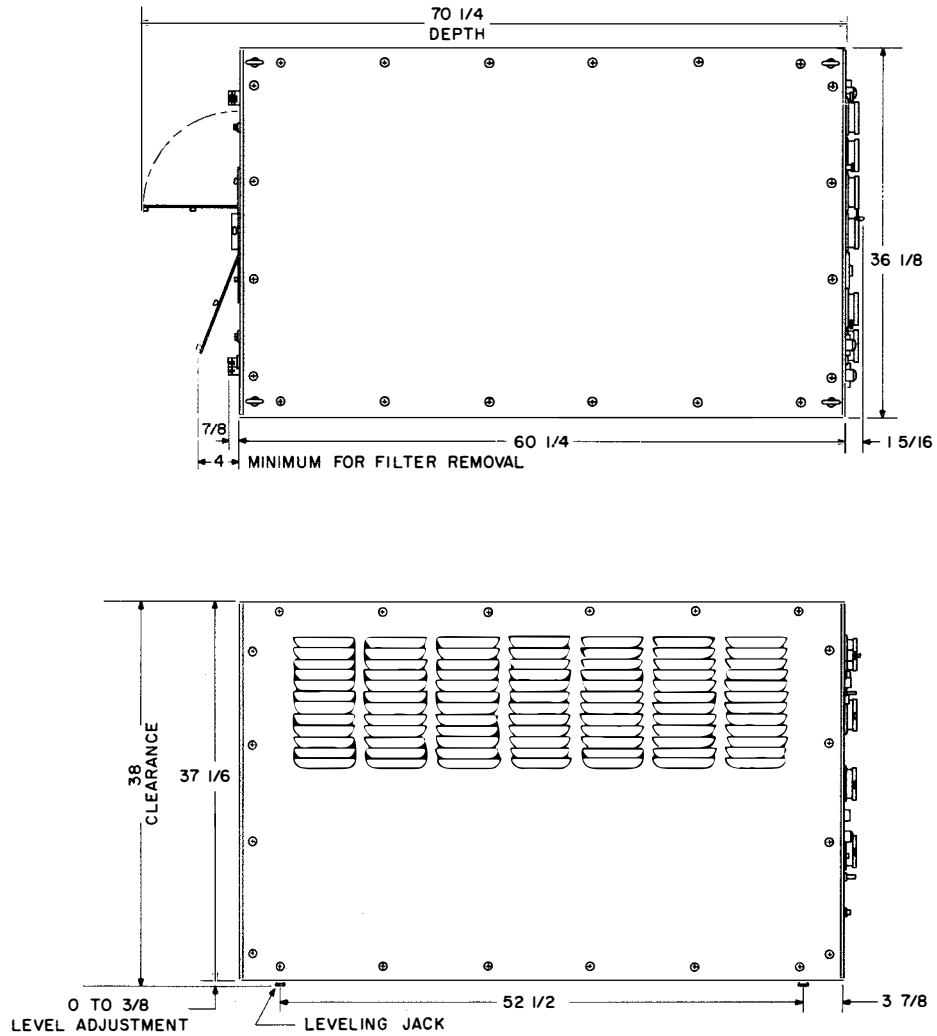

WEIGHT 630 LBS
RF INPUT POWER
PER CHANNEL WATTS 3KW-AM, 10KW-SSB
LINE VOLTAGE 115VOLTS 60 CPS
POWER-BLOWER LINE WATTS 108
MAX HEAT DISSIPATION WATTS 3000
TEMPERATURE RANGE CLASS 4
0°C TO 50°C
(+32°F TO 122°F)
RECOMMENDED HEAD ROOM 40 INCHES
FAN LUBRICATION-(NOT REQUIRED)

NOTES
1. DIMENSIONS IN INCHES ($\pm 1/16$)
2. ALLOW AMPLE CLEARANCE
AROUND UNIT FOR MAINTENANCE
MIN REAR: 2 1/2 FEET
MIN SIDES: 2 1/2 FEET
MIN FRONT: 2 1/2 FEET

TERMINAL STRIPS AND CONNECTORS

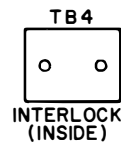
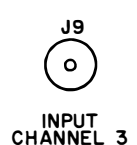
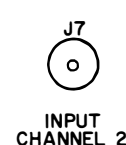
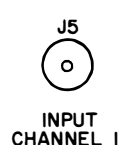
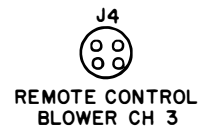
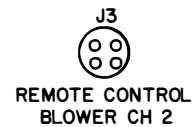
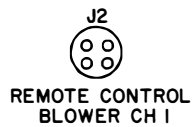
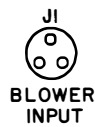

Figure 2-1. Antenna Coupler Group AN/FRA-49(V), Outline Drawing

(a.) Connect the wires from pins A and B to the equipment side of the transmitter power switch so as to supply 115 vac to pins A and B when transmitter power is turned on.

(b.) Connect the wires from pins C and D (a normally-closed set of relay contacts) so as to operate the transmitter overload-shutdown circuits when the relay contacts open.

TABLE 2-1. ANTENNA COUPLER GROUP AN/FRA-49(V), TRANSMITTER CABLE FABRICATION AND CONNECTION (THREE REQUIRED)

CONNECTOR	PROCEDURE	USE
P5, P7 or P9 (UG-154/U)	<ol style="list-style-type: none"> 1. Connect one end of a section of RE-35 B/U or RG-164/U, co-axial cable (of sufficient length) to one of the three UG-154/U connectors supplied with the unit. 2. Connect the other end of the cable to the r-f output connector (of the associated transmitter). 	Couple transmitter output to antenna coupler input.

TABLE 2-2. ANTENNA COUPLER GROUP AN/FRA-49(V), ANTENNA CABLE FABRICATION (ONE REQUIRED)

CONNECTOR	PROCEDURE	USE
P11 (Aluminum coupling half)	<ol style="list-style-type: none"> 1. Connect the coupling half to a suitable length of semi-flexible co-axial cable such as Styroflex cable RG-248/U (Phelps Dodge Copper Productions Corporation, New York). 2. Connect the other end of the cable to a suitable connector for the antenna. 	Connects antenna coupler group to antenna.

TABLE 2-3. ANTENNA COUPLER GROUP AN/FRA-49(V), REMOTE CONTROL CABLE FABRICATION (THREE REQUIRED)

CONNECTOR	PROCEDURE
P2, P3 or P4 (Type MS3106A14S-2S)	<ol style="list-style-type: none"> 1. Cut a suitable length of Belden number 8424 four-conductor cable or an equivalent per MIL-C-3432. 2. Identify and mark each wire end. 3. Solder one conductor to each pin of the connector. 4. The remaining end of the four-conductor cable connects to the associated transmitter as follows: <ul style="list-style-type: none"> Pins A and B --115 vac primary power circuit Pins C and D --Overload shutdown circuit 5. Repeat the procedure for the other two cables.

(4) POWER CABLE. - Fabricate a power cable as indicated in table 2-4. Connect one end of the cable to the BLOWER INPUT jack at the rear of the electrical equipment cabinet. Connect the other end of the cable as follows:

Connect pins B and C to the a-c source. When an unbalanced or a grounded power distribution system is used to supply the power, connect pin B to the neutral wire or to the grounded wire.

(5) ELECTRICAL EQUIPMENT CABINET INTERLOCK CABLE. - Series connected interlock switches open automatically whenever either side of the electrical equipment cabinet is removed. Connections to these switches are available on TB4.

When it is deemed necessary, a power disconnect device (not supplied) for the transmitters may be connected to TB4 in which case the interlock switches will become the control switches for the disconnect device.

(6) LIGHTNING PROTECTION CABLES AND DEVICES. - There are no lightning protection devices as such in Antenna Coupler Group AN/FRA-49(V). Adequate grounding of the equipment shall be provided for.

WARNING

R-f voltages dangerous to life are present in r-f sections of the antenna coupler group.

TABLE 2-4. ANTENNA COUPLER GROUP AN/FRA-49(V),
POWER CABLE FABRICATION (ONE REQUIRED)

CONNECTOR	PROCEDURE	USE
P1 (Type MS3108-5S)	<ol style="list-style-type: none"> 1. Select a medium grade flexible, three-conductor cable such as CO-03MGF(3/16)0360 per MIL-C-3432. 2. Cut a suitable length of this cable. 3. Identify and mark each wire end. 4. Form and tin one end of each wire using acid-free solder. 5. Solder the other end of the wires to the following pins of the connector: <ul style="list-style-type: none"> Pin A Pins B and C 	<p>Connects:</p> <p>Electrical equipment cabinet ground wire</p> <p>115 vac</p>

2-4. INSPECTION AND ADJUSTMENTS.

Note

Emergency shut-off of r-f power is accomplished by disconnecting all REMOTE CONT. BLOWER connector cables. This actuates the transmitter overload-shutdown circuits.

Connect the positioned unit to the transmitters and to the antenna using such additional fittings, hardware, and mounting brackets as necessary. Complete the following inspection and adjustments before the initial energization and operation of the antenna coupler group is attempted.

Note

Remove both sides and the top of the electrical equipment cabinet before proceeding.

a. MECHANICAL INSPECTION. - Inspect the installed unit and correct all mechanical defects. Operate each tuning control to the mechanical stop. Observe that stops are positive and that controls operate smoothly without binding. Dial readings should be 0000 to 0028 for COUPLING and 000 to 0057 for TUNING for Antenna Coupler CU-998/FRA-49(V) and 0000 to 0022 for COUPLING and 0000 to 0050 for TUNING for Antenna Coupler CU-999/FRA-49(V).

b. ELECTRICAL INSPECTION. - Visually inspect the various electrical components such as cables, switches, fuse mountings and fuses for obvious defects. Make certain that cable connectors and adaptors are securely joined and that lock rings are tightened.

CAUTION

Do not disturb settings of resistors R2, R4 and R6 located on meter boxes. These adjustments are made at the factory.

Test fuse mounts for possible short-circuit. Extract each fuse holder from the mounting and remove the fuse. Make an ohmmeter resistance measurement across the two ferrule clips. Correct any defects.

c. PRE-OPERATION TEST AND CHECKS. - The unit does not require pre-operation testing or checks.

d. INITIAL TUNING ADJUSTMENTS. - Upon completion of inspections the antenna coupler group is ready for initial tuning. Shut off the three associated transmitters.

Note

Connect a properly tuned transmitter to the channel to be tuned.

Tune each channel as follows:

(1) Start with the transmitter connected at INPUT 75 Ω CHANNEL 2 and REMOTE CONT. BLOWER CH. 2.

(2) Set TUNING AND COUPLING controls of channel 2 to approximate positions for the frequency indicated on tuning graphs on the front panel. See Section 6 for typical values of approximate TUNING and COUPLING shaft positions (see figures 6-3 and 6-4).

CAUTION

De-couple the other antenna couplers or tune them for a frequency separation greater than 10 per cent (see paragraph 1-4).

(3) Place the channel BLOWER SWITCH to the ON position.

(4) Energize the associated transmitter and tune the antenna coupler to the transmitter operating frequency. Operate transmitter at reduced power initially. Further, de-couple the transmitter power amplifier so as to minimize the transmitter output.

(5) Set the associated monitor selector switch to the VSWR position. Advance the CAL adjustment knob until the meter provides a half-scale reading. Turn the TUNING control to obtain a null on the meter.

note

As the tuning progresses, it will be necessary to readjust the associated CAL control to provide maximum reading.

(6) Trim the associated COUPLING control to obtain minimum meter reading.

(7) Return the associated transmitter to full output position or operating power.

(8) Retrim both controls until the lowest possible VSWR is obtained.

(9) Set the associated monitor selector switch to the CAL (calibrate) position. Use the associated CAL adjustment knob to bring the meter pointer to the ∞ mark (full scale). VSWR measurements are now possible. (Refer to paragraph 2-4e(3) for protection circuit settings.)

(10) To check the VSWR reading, switch to the VSWR position.

Note

The monitor selector switch FOR (forward) position is used for measurement or setting of r-f power delivery.

(11) Place associated monitor selector switch in OPR position.

CAUTION

Leave the monitor selector switch in the OPR position whenever adjustments and measurements are completed, to enable operation of the overload protection device.

Note

The transmitter tuning controls may require slight retrimming. Final settings may be slightly different from the chart values due to antenna impedance deviation.

(12) Lock the controls of the fully tuned antenna coupler in position using the thumb-screw LOCK mechanism. Return the tuning dial knob cranks to the recessed positions.

(13) Record finalized setting in pencil under the applicable column heading of the front panel tuning graph. List the channel frequencies in kilocycles. If the channel or commonly-used frequency has been assigned a name or other identification, list this information in abbreviated form.

(14) Repeat the procedure for the other two channels. Make certain that the tuned frequencies differ by at least 10 per cent (paragraph 1-4.)

CAUTION

Set the COUPLING control of the channel being tuned to 0000 if it is necessary to tune through the frequency of other channels.

e. PROTECTION CIRCUIT ADJUSTMENTS. - Each of the three meter relays (one for each channel) must be adjusted to deactivate the associated transmitter when a VSWR of 3.5 to 1 occurs. Each meter relay, located in the upper left corner behind the front panel, is adjusted as follows:

(1) Place the channel 1 front-panel monitor selector switch in the VSWR position. After meter is calibrated, see paragraph 4-2c.

(2) Record the initial setting of the channel 1 TUNING control (from the counter) and then vary the

control until a VSWR of 3.5 or less is indicated on the front panel meter.

Note

Transmitter must be operating with normal power output when reading VSWR of 3.5 because the protection circuits will be activated at other VSWR levels if input power is changed.

(3) Place the channel 1 monitor switch in the OPR position and proceed to the rear of the front panel.

(4) Slowly turn the zero-adjust screw of meter relay K5 (K7 is for channel 2 and K9 is for channel 3) until transmitter interruption occurs.

(5) Return the channel 1 TUNING control to the position recorded in step 2.

(6) Repeat steps (1) through (5) for the other two channels.

Note

Other values of VSWR (not to exceed 3.5) can be used to actuate the relay meter if so desired. When VSWR values other than 3.5 are desired, vary the TUNING setting, step (2), to the desired VSWR.

(7) Replace the electrical equipment cabinet sides and top.

2-5. INTERFERENCE REDUCTION.

Interference reduction procedures are not required.

2-6. PREPARATION FOR RESHIPMENT.

When the antenna coupler group is to be reshipped, perform the following procedure:

a. Remove the antenna couplers from the antenna coupler group. Follow the antenna coupler removal procedure presented in Section 6.

b. Remove the large and the small glass-enclosed variable capacitors from the antenna couplers, using the removal procedure presented in Section 6.

c. Reassemble all capacitor mounting hardware and then reassemble the antenna couplers.

d. Remove all cables from the antenna coupler group.

e. Disassemble the cables and reclaim or replace all connectors originally supplied with the equipment (all connectors which mate with the coupler jacks, see table 1-1).

f. Pack the three antenna couplers, the electrical equipment cabinet, and the tuning capacitors in separate crates or boxes having the dimensions indicated in table 1-2. Pack the connectors and this manual inside of the electrical equipment cabinet. Use any means necessary to protect the crated or boxed parts from damage due to rough handling. Prevent the connectors and this manual from moving around or from damage within the electrical equipment cabinet.

SECTION 3
OPERATOR'S SECTION

3-1. OPERATING PROCEDURES.

Antenna Coupler Group AN/FRA-49(V) does not require an operator in attendance. All tuning and adjustment procedures are performed by skilled technicians and are described in Section 2.

3-2. EMERGENCY OPERATION.

Emergency operating procedures are performed by skilled technicians and are presented in Section 6.

CAUTION

The antenna coupler must be retuned when the associated transmitter frequency is changed. Repeat required steps as described in Section 2 (paragraph 2-4d) to prevent damage to the unit.

SECTION 4

PRINCIPLES OF OPERATION

4-1. OVERALL FUNCTIONAL DESCRIPTION.

Antenna Coupler Group AN/FRA-49(V) (see figure 4-1) consists of three independent and identical channels connected to a common broadband antenna. Each channel consists of r-f circuits, metering circuits, protection circuits, and additional auxiliary circuits.

a. R-F CIRCUITS. - Radio frequency signals are applied through a directional coupler to an antenna coupler. Input signals at the tuned frequency are electro-magnetically coupled by the antenna coupler to a pick-up loop. The three pick-up loops used in the antenna coupler group are series-connected to a common broadband antenna. In this manner three radio transmitters can use the same broadband antenna for the simultaneous transmission of three ~~amplitude modulated or single side band messages.~~ *amplitude modulated or single side band messages.*

Antenna Coupler CU-998/FRA-49(V) is tuned to respond to signal inputs in the 2 to 6 megacycle frequency range. Antenna Coupler CU-999/FRA-49(V) is tuned to respond to input signals in the 5 to 15 megacycle range. Electrical Equipment Cabinet CY-3409/FRA-49(V) is used with both types of antenna coupler.

b. METERING AND PROTECTION CIRCUITS. - Each channel is supplied with an R. F. INDICATOR meter and a protection circuit. The meter indicates forward power and voltage standing-wave ratio (VSWR). The meter is used during r-f tuning procedures and during trouble-shooting procedures.

The protection circuit opens a set of relay contacts when the VSWR exceeds 3.5 to 1 or any other ratio selected by positioning the fixed contact on a meter relay when the monitor selector switch is in the OPR position "When properly connected to ~~overload~~ *external circuitry*".

The ~~voltage~~ *power* which operates the meter and the protection circuit is obtained from the associated directional coupler. A monitor selector switch is used to select the forward ~~voltage~~ *power* sampled by the directional coupler from the transmitter, or it can select the reflected ~~voltage~~ *power* (from the antenna and antenna coupler) which is sampled by the directional coupler.

c. ADDITIONAL AUXILIARY CIRCUITS. - Additional circuits include a small power supply, blowers, transmitter-operated blower control relays and a safety interlock. The power supply provides d-c voltage for the protection circuits. Three blowers cool their respective antenna couplers by drawing filtered air from the rear of the electrical equipment cabinet and blowing it through the center of the antenna coupler. The blower control relays are energized by ac from the associated transmitter. As a result, the blowers are automatically disconnected from power when the associated transmitter is not energized. The safety switches provide a switch opening when either side of the electrical equipment cabinet is removed. These switches can be connected to interrupt power to the associated transmitters when the antenna coupler group is being serviced.

4-2. FUNCTIONAL SECTIONS.

Each identical channel of Antenna Coupler Group AN/FRA-49(V) consists of four functional sections (the pick-up loops are part of the antenna couplers):

- (1) Directional coupler
- (2) Antenna coupler
- (3) R. F. INDICATOR meter
- (4) Protection circuit

a. DIRECTIONAL COUPLER. - All radio frequency input signals are applied to the antenna coupler through the directional coupler. A small portion of the energy passing through the directional coupler is rectified by associated semi-conductor diodes. The rectified r-f voltage available at the red-banded output jack (see figure 4-2) is a sample of the ~~energy~~ *power* being applied by the associated transmitter. The rectified r-f voltage available at the yellow-banded output jack is a sample of the ~~voltage~~ *power* being reflected by the antenna coupler and the broadband antenna. These rectified voltages operate the meter and protection circuit.

b. ANTENNA COUPLER. - The antenna coupler is a parallel resonant circuit capable of handling high-power r-f signals. A fixed inductance and variable capacitors are used for tuning. The capacitance values are varied as a tuning shaft on each capacitor is rotated. The capacitor shafts are geared together and coupled to the associated TUNING knob on the front panel.

The energy applied to the inductor is electro-magnetically coupled to the pick-up loop. The amount of coupling is determined by the physical closeness of the tuning inductance and the pick-up loop.

The tuning inductance is a helical single-layer coil of tubing. The pick-up loop is a single turn coil encircling the tuning inductance. Both elements are mounted inside of the antenna coupler. The two terminals of the pick-up loop protrude from the side of the antenna coupler through a rectangular slot running along the long dimension of the antenna coupler.

The terminals of the pick-up loop are rigidly fastened in a junction box mounted on the frame of the electrical equipment cabinet. The entire antenna coupler is free to move a short distance along the length of the electrical equipment cabinet.

Coupling is varied when the entire antenna coupler assembly is moved (on trundle wheels along a set of tracks) towards and away from the non-moving pick-up loop. This is accomplished by a lead screw mounted on the antenna coupler and coupled to the COUPLING knob on the front panel.

Mechanical counters are used to indicate the number of turns made by the TUNING and the COUPLING shafts.

c. R. F. INDICATOR METER. - The R. F. INDICATOR meter is calibrated to indicate input power and voltage standing-wave ratios.

The associated monitor selector switch (see figure 4-3) connects the rectified voltage from the directional coupler to the meter. When the switch is

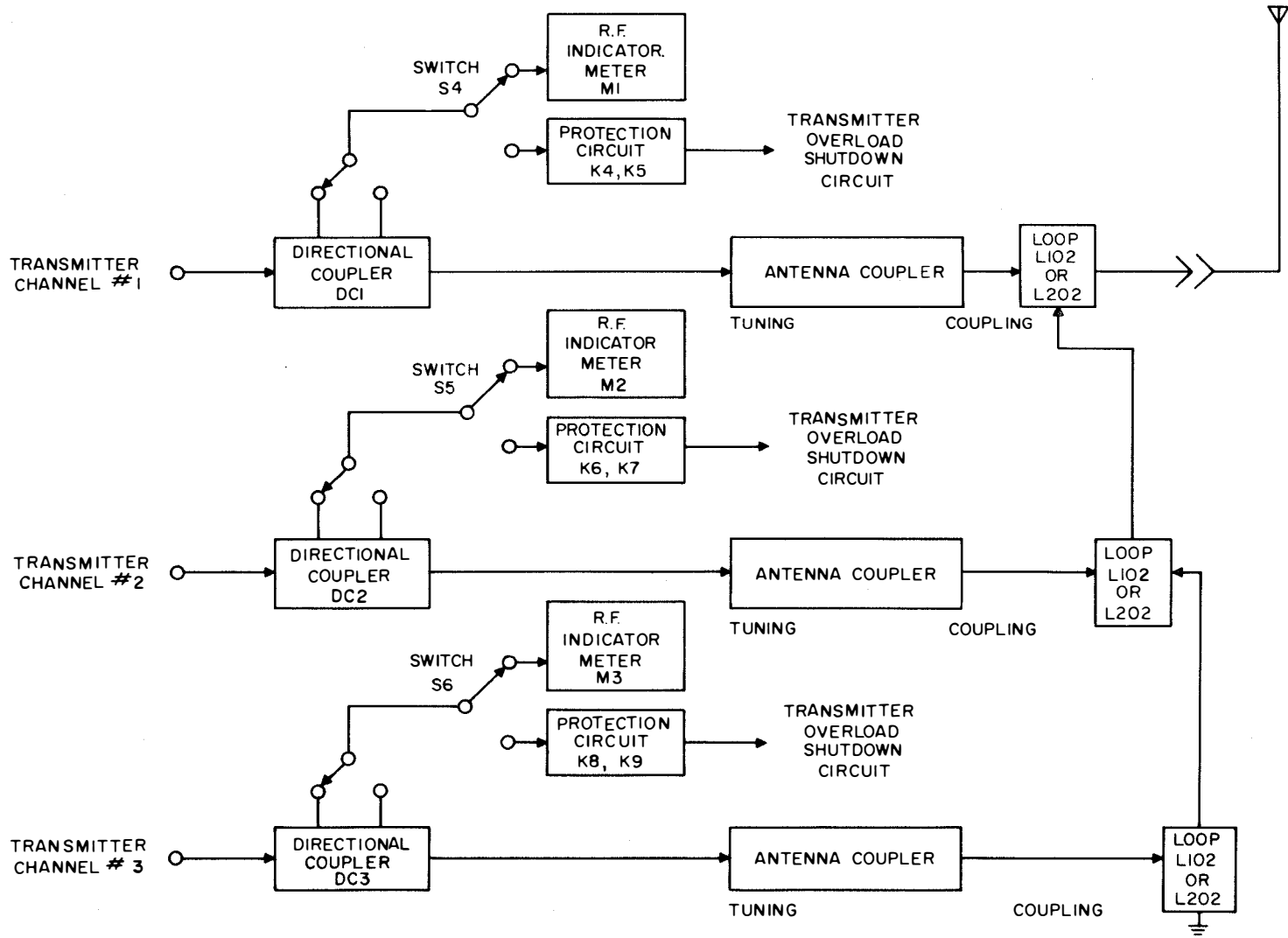
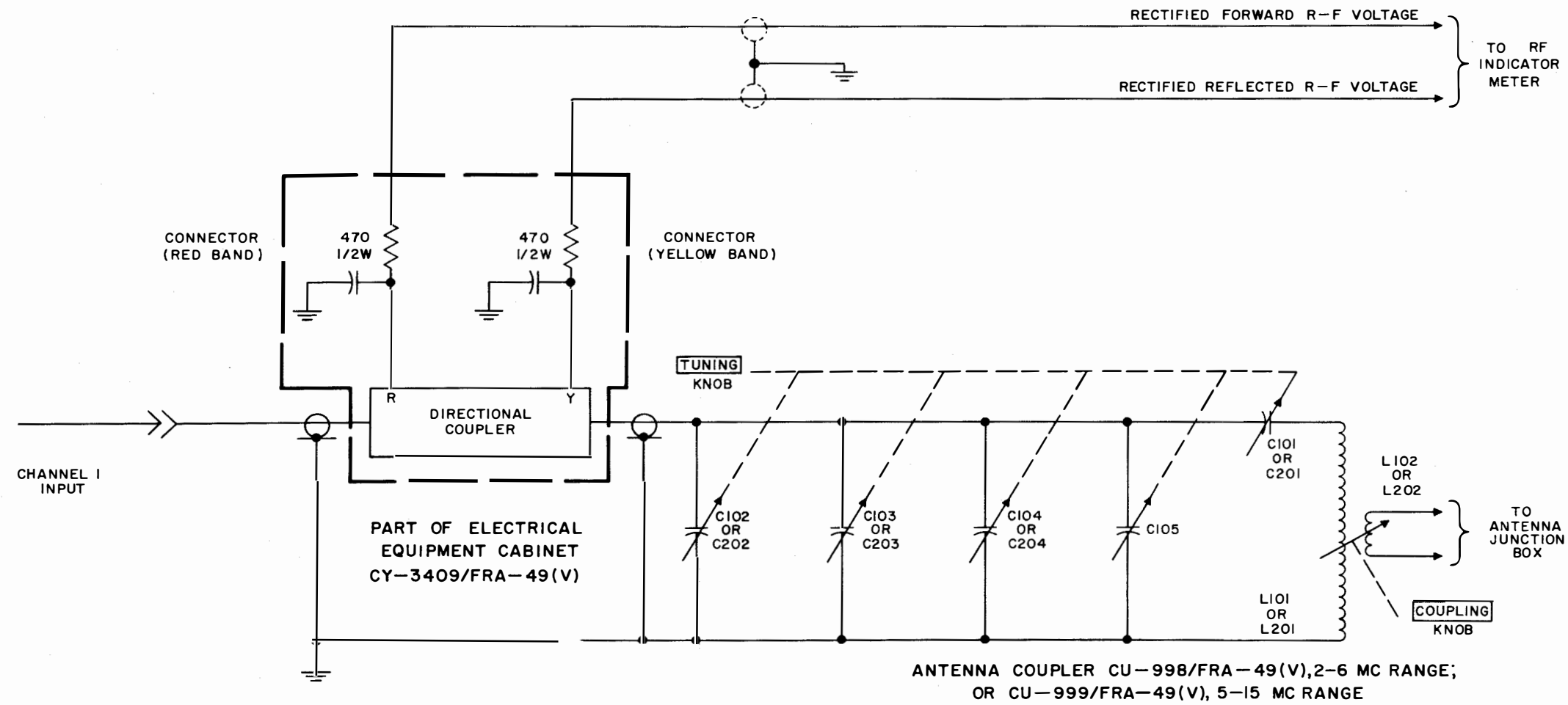

Figure 4-1. Antenna Coupler Group AN/FRA-49(V), Overall Functional Block Diagram





TYPE	SYMBOL	VALUE
CU-998	C101	30-650 UUF
CU-998	C102-C105	150-2750 UUF
CU-998	L101	
CU-998	L102	COUPLING LOOP
CU-999	C201	25-450 UUF
CU-999	C202-C204	100-2000 UUF
CU-999	L201	
CU-999	L202	COUPLING LOOP

Figure 4-2. Typical Directional Coupler and Antenna Coupler (Channel 1), Simplified Schematic Diagram

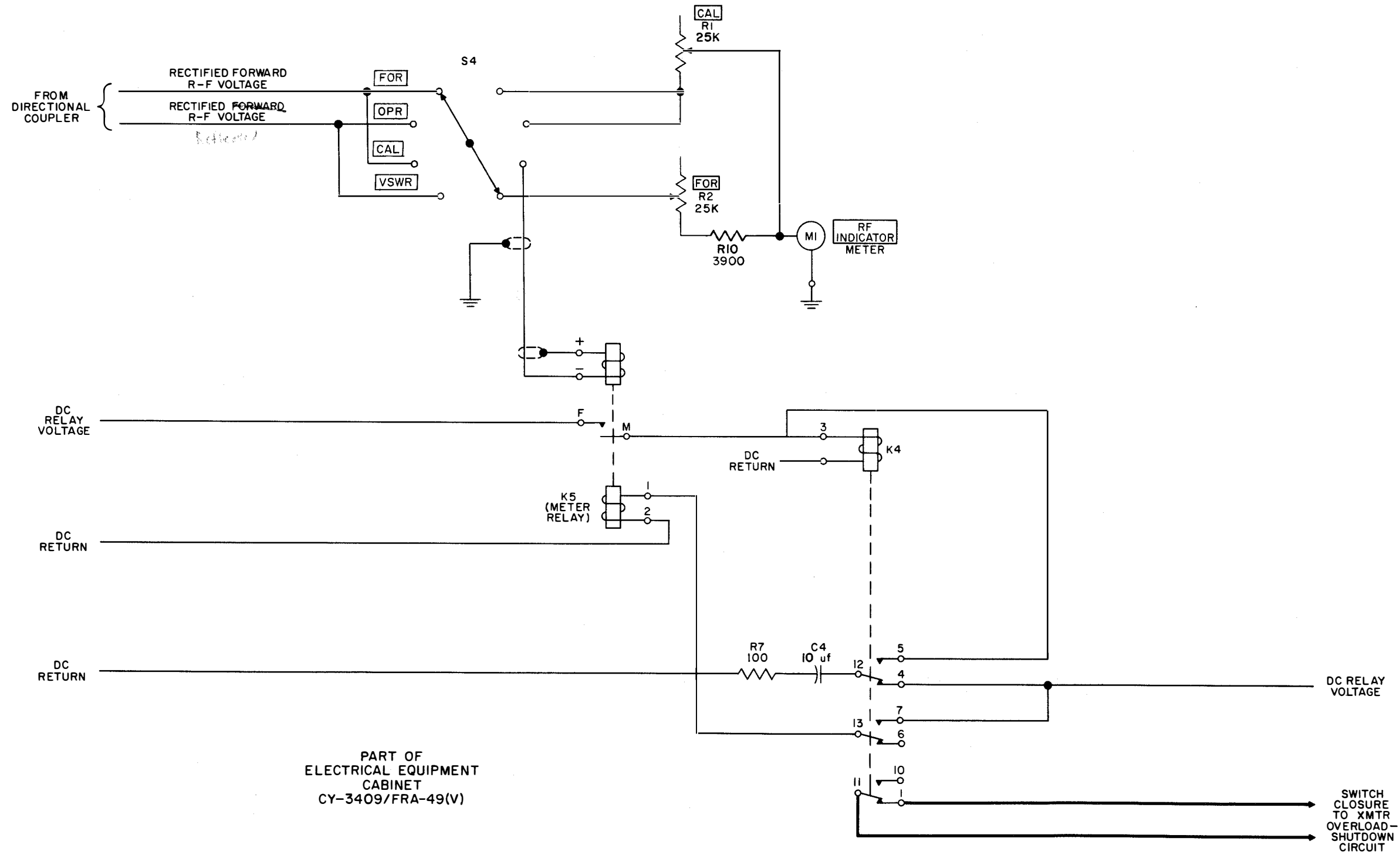

Figure 4-3. Typical R. F. INDICATOR Meter and Protection Circuit (Channel 1),
Simplified Schematic Diagram

See T. 2

in the FOR position, the rectified sample of power received from the associated transmitter is connected through the FOR potentiometer to the meter. The FOR potentiometer is factory calibrated.

When the switch is in the CAL position the rectified sample of the transmitter signal is applied to the meter movement through the CAL potentiometer. The correct value of VSWR is indicated when the CAL potentiometer is properly calibrated. To calibrate, the CAL potentiometer is adjusted to cause a deflection to the ∞ mark on the meter. In this manner, the rectified portion of the input voltage (FOR) is used as a reference for the indication of reflected voltage.

When the monitor selector switch is placed in the VSWR position, the fraction of the input voltage which is reflected back causes a meter indication which represents the reflected voltage relative to the forward voltage.

d. PROTECTION CIRCUIT. - When the monitor selector switch is in the OPR position the rectified reflected r-f voltage from the directional coupler is applied to the deflection coil of the meter relay in the protection circuit. The rectified voltage causes the pointer of the meter to contact a fixed contact

when the VSWR exceeds 3.5 or any other value selected by positioning of the meter pointer. The associated relay, K4 in this case, is actuated by the meter relay contact closure. As a result:

(1) Contacts K4-7 and -13 close and energize a reset coil on meter relay K5. This causes the meter relay contacts to open, thus removing d-c relay voltage from the coil of relay K4. Relay K4 does not drop out at this time because of contacts K4-12 and -5.

(2) Contacts K4-4 and -12 open and remove d-c relay voltage from capacitor C4A and resistor R7. At the same time, contacts K4-12 and -5 close and connect the charged capacitor to the coil of relay K4. Thus the relay stays energized until the capacitor discharge current falls below the relay drop-out value. The interval before drop-out is approximately 250 to 300 milliseconds.

(3) Contacts K4-1 and -11 open during the interval that relay K4 is energized. As a result, the transmitter overload-shutdown circuits are actuated for 250 to 300 milliseconds.

e. ADDITIONAL AUXILIARY CIRCUITS. - The auxiliary circuits are conventional and are shown in the full schematic diagram presented in Section 6.

SECTION 5
TROUBLESHOOTING

5-1. GENERAL.

The functional and electrical simplicity of Antenna Coupler Group AN/FRA-49(V) makes it possible to locate rapidly the source of trouble indications and to isolate the faulty part. When trouble is localized refer to the removal and replacement procedures given in Section 6.

a. TROUBLE-SHOOTING PROCEDURE. - The trouble-shooting procedure for the antenna coupler group consists of overall trouble-shooting, which includes visual inspection and functional section trouble-shooting. For the purpose of this manual it is assumed that preliminary trouble-shooting has localized the trouble to the antenna coupler group. The nature of the trouble will immediately localize the malfunction to one of the three identical channels or to the common antenna coupling circuit.

b. TROUBLE INDICATIONS. - Radio-frequency signal troubles will be indicated (see table 5-7) by:

- (1) Absence of power at the common antenna.
- (2) Periodic interruption of transmitter operation as a result of the associated antenna coupler protection circuit.

Meter circuit troubles will be indicated when the R. F. INDICATOR meter of the associated channel does not properly indicate power or VSWR conditions known to exist.

Protection circuit troubles will be indicated when periodic adjustments of the meter relay of a channel fail to result in shutdown of the associated transmitter.

5-2. TEST EQUIPMENT AND SPECIAL TOOLS.

A multimeter and a vtm are the only pieces of test equipment required for trouble-shooting the antenna coupler group (see table 5-1). Additional trouble-shooting is performed using the R. F. INDICATOR meters associated with each channel. No special tools are required.

5-3. OVERALL TROUBLE-SHOOTING.

The overall trouble-shooting of the antenna coupler group is accomplished by using the following procedures:

a. PRELIMINARY CHECK. - Make sensory observations as the first step in localizing the cause of trouble. Make sure that both sides of the antenna coupler group are firmly in place (interlock switches closed). The following observations should be made:

(1) Check the settings of the TUNING and COUPLING controls of each channel against the tuning chart on the front panel. Make sure that each channel is tuned to the same frequency as the associated transmitter. If this is not the case, continue checking the antenna coupler group for possible damage due to the impedance mismatch.

(2) Observe the BLOWER indicators on the front panel. If any of the indicators are off when the associated transmitter is on, refer to the functional-section-trouble-shooting chart dealing with the blower circuits.

(3) Feel the blower intakes to check blower operation. If no air flow is felt, refer to the functional-section-trouble-shooting chart dealing with the blower circuits.

WARNING

R-f voltages dangerous to life are present in the r-f sections of the antenna coupler group.

(4) Remove the electrical equipment cabinet top panel and note any smell of burning insulation coming from the antenna couplers. If this smell is noted, and the blowers are in satisfactory condition, refer to the functional-section-trouble-shooting chart dealing with the antenna coupler. This symptom is associated with prolonged inductive arc-over that has resulted in charring of the insulators in an antenna coupler.

TABLE 5-1. TEST EQUIPMENT

NAME	TYPE	ALTERNATE	USE
Multimeter	AN/PSM-4C	Triplet 630A	Measure voltage, resistance, and current
vtm	AN/USM-116	ME-25/U	Measure voltage

(5) Listen for the sound of arcing. Locate any element doing so and check protection circuit.

(6) Visually inspect the inside of the electrical equipment cabinet for charred insulation, broken wires, charred resistors, and ruptured or melted capacitors. Replace any components found in this condition.

Note

Do not remove the electrical equipment cabinet sides if an interlock cable is connected to TB4 which is behind the rear panel (upper left, when viewed from front of electrical equipment cabinet).

b. CONTROL SETTINGS AND OPERATING CONDITIONS. - Place all BLOWER switches in ON position. Apply r-f power to all channels by operating the associated transmitters.

CAUTION

When using the transmitters as r-f power sources in trouble-shooting always operate at reduced power. Use power inputs of approximately 500 watts.

c. SYSTEM TROUBLE-SHOOTING CHART. - Use the system trouble-shooting chart (table 5-2) as a methodical trouble-detecting and fault-isolating procedure. Use the chart in conjunction with the system block diagram (figure 4-1) and the full schematic diagram (figure 6-18).

However, check table 5-7 before performing system trouble-shooting. Table 5-7 presents typical troubles. In some cases, the trouble will be typical and more direct trouble-localization procedures will be possible.

5-4. FUNCTIONAL SECTION TROUBLE-SHOOTING.

Functional section trouble-shooting procedures are used for localizing trouble with the R. F. INDICATOR meter circuit, the protection circuit, the directional coupler and antenna coupler, the antenna circuit, and the blower circuit.

a. PRELIMINARY CHECK. - Perform the preliminary checks outlined in paragraph 5-3a. Concentrate on the functional section indicated by table 5-2 as being the probable cause of trouble.

b. TEST EQUIPMENT AND SPECIAL TOOLS. - Use the multimeter and vtvm described in table 5-1. The vtvm and probe are used for r-f and meter circuit trouble-shooting. The multimeter is used for all other measurements.

c. CONTROL SETTINGS AND OPERATING CONDITIONS. - Maintain the conditions described in paragraph 5-3b. Remove the sides of the electrical equipment cabinet and jumper the interlock (TB4, pins 1 and 2, on the upper left behind the rear panel).

WARNING

R-f voltages dangerous to life are present in the r-f sections of the antenna coupler group.

TABLE 5-2. ANTENNA COUPLER GROUP AN/FRA-49(V)
SYSTEM TROUBLE-SHOOTING CHART

STEP	PRELIMINARY ACTION	NORMAL INDICATION	NEXT STEP
1	Set each monitor selector switch to the CAL position and set each CAL adjustment to provide a meter deflection to the mark on each R. F. INDICATOR meter.	Each meter pointer should deflect to the mark.	If indication is normal proceed to step 2. If not, refer to the functional section trouble-shooting chart for the R. F. INDICATOR meter.
2	Set each monitor selector switch to the VSWR position.	Each meter should indicate a VSWR of less than 3.5.	If indication is normal proceed to step 3. If not, refer to the functional section trouble-shooting procedure for the antenna coupler.
3	Set each monitor selector switch to the OPR position and observe the meter relays on the inside of the front panel.	The pointer should point to some position other than straight down.	If indication is normal, proceed to step 4. If not, refer to the functional section trouble-shooting chart for the protection circuit.
4	Retune the transmitter associated with channel 1 until it delivers rated power.	The protection circuit should not operate the transmitter overload-shutdown circuits. No r-f arcing should occur in the associated antenna coupler.	If the indication is normal, proceed to step 5. If not, decouple the transmitter in order to reduce the input power to 500 watts and refer to the functional section trouble-shooting chart for the antenna coupler.
5	Repeat step 4 for channels 2 and 3.	(Same)	(Same)

d. FUNCTIONAL SECTION TROUBLE-SHOOTING CHARTS. - The procedures used for functional section trouble-shooting are presented in tables 5-3 through 5-6.

CAUTION

The maximum current which can flow through the R. F. INDICATOR meter is 20 microamperes. The maximum meter relay current is 50 microamperes. When checking continuity of these meters use the one megohm resistor in series with the multimeter. Use the lowest multimeter resistance range and observe the pointer of the meter under test. Disconnect the directional coupler voltage when making resistance or continuity measurements.







5-5. TYPICAL TROUBLES.

Some typical troubles which may be encountered with the antenna coupler group are presented in table 5-7.

5-6. LOCATION OF PARTS.

The locations of all parts and test points used for trouble-shooting are identified in figures 5-1 through 5-3. Partial schematic diagrams are not presented owing to the simplicity of the full schematic. Voltage and resistance diagrams are not required in that the antenna coupler group has no vacuum tubes or transistors.

TABLE 5-3. ANTENNA COUPLER GROUP AN/FRA-49(V), R. F. INDICATOR METER CIRCUIT, FUNCTIONAL SECTION TROUBLE-SHOOTING CHART

STEP	TEST POINT	PRELIMINARY ACTION	NORMAL INDICATION	NEXT STEP
1	 Figure 5-1 or  or 	Use vtvm to measure voltage.	D-c voltage of approximately 50 millivolts present.	If any voltage is detected proceed to step 2. If no voltage is detected, check red cable*. Replace directional coupler if necessary. Repeat step 1.
2		Place the monitor selector switch in the FOR position.	Power indication, on R. F. INDICATOR meter, of approximately 500 watts.	If any power indication is present, proceed to step 3. If not, check associated FOR potentiometer, meter, and monitor selector switch. Be careful to limit meter current to 20 microamperes. Repeat step 2.
3	 Figure 5-1 or  or 	Use vtvm to measure voltage.	D-c voltage of approximately 50 millivolts present.	If voltage is detected, proceed to Step 4. If no voltage is detected, check yellow cable. Replace directional coupler if necessary. Repeat Step 3.
4		Place the monitor selector switch in the VSWR position.	VSWR indication.	If indication is absent, check switch and meter. Be careful to limit current flow through the meter to 20 microamperes. Use the 1 Meg series resistance and the lowest range on the resistance portion of the multimeter.

*Note: Each cable has an internal resistance of 470 ohms.

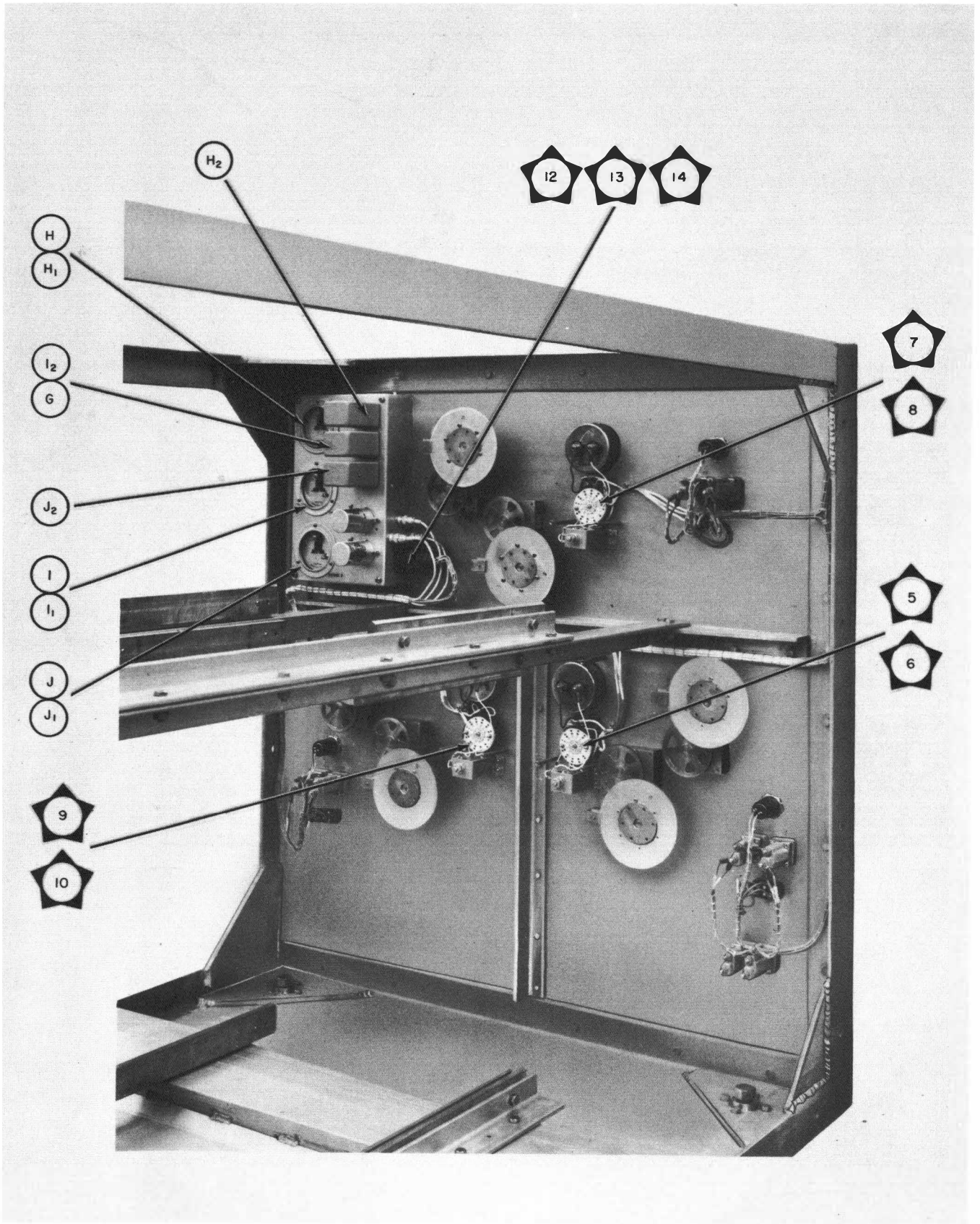

5-1. Electrical Equipment Cabinet CY-3409/FRA-49(V), Inside Front Panel

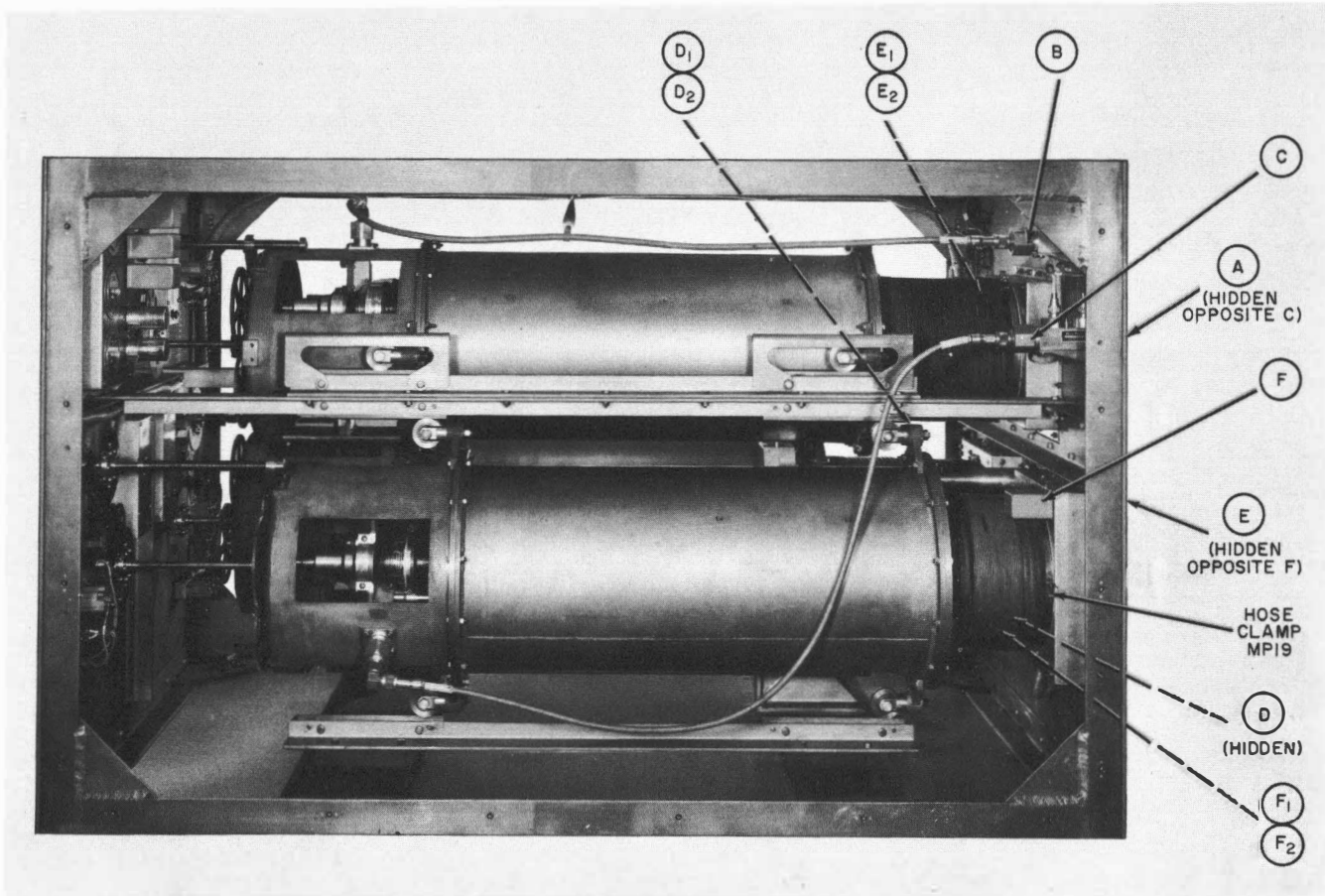
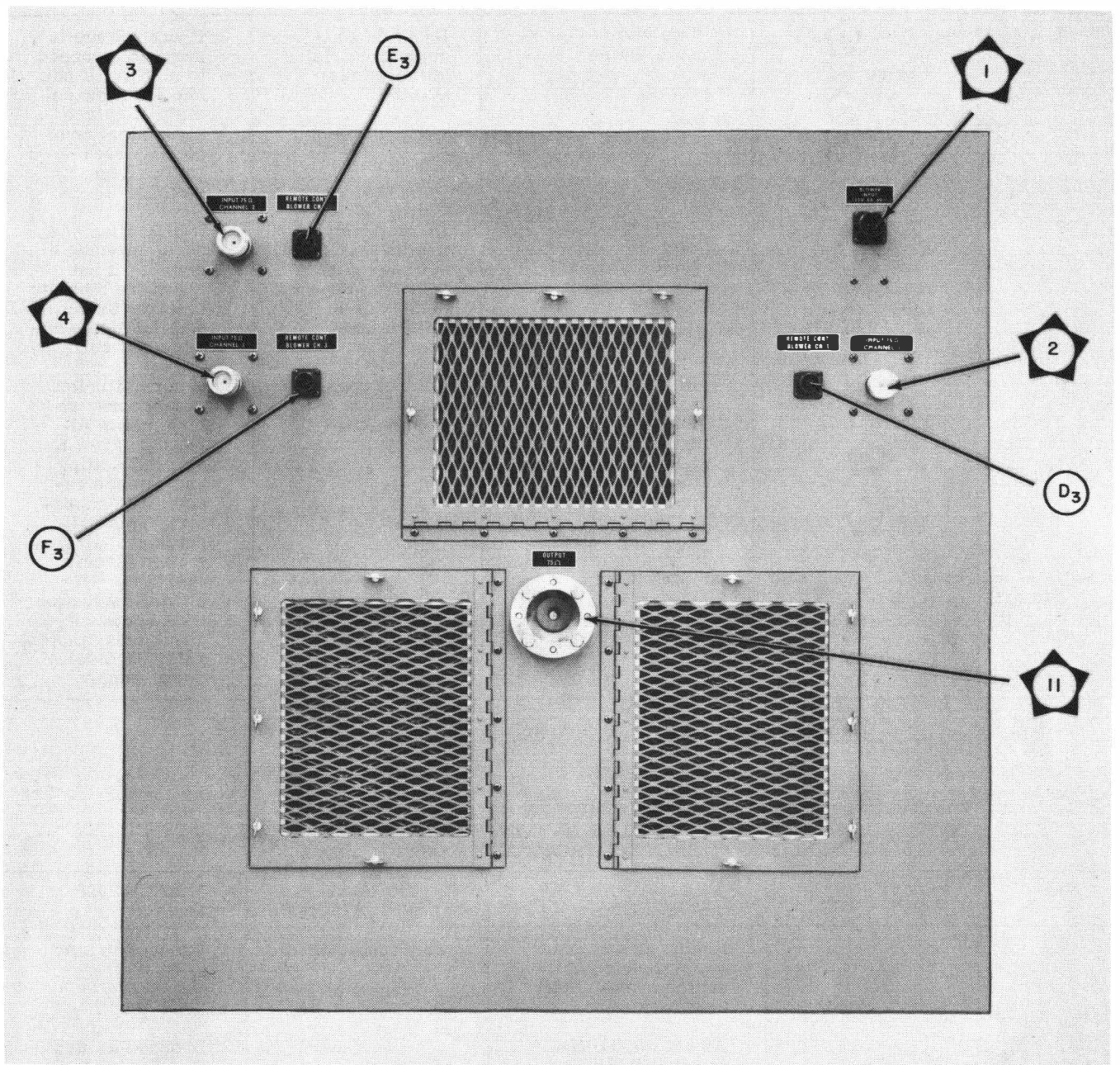











Figure 5-2. Electrical Equipment Cabinet CY-3409/FRA(V), Right Side View (Sides Removed)



5-3. Electrical Equipment Cabinet CY-3409/FRA-49(V), Rear Panel

TABLE 5-4. ANTENNA COUPLER GROUP AN/FRA-49(V),
PROTECTION CIRCUIT, FUNCTIONAL SECTION
TROUBLE-SHOOTING CHART

STEP	TEST POINT	PRELIMINARY ACTION	NORMAL INDICATION	NEXT STEP
1	 Figure 5-1 or  or 	Use vtvm to measure voltage.	D-c voltage of approximately 50 millivolts present.	If any voltage is present, proceed to step 2. If not, check yellow cable*. Replace directional coupler if necessary. Repeat step 1.
2	 Fig 5-1 or  or 	Place the associated monitor selector switch in the OPR position.	Deflection of pointer on associated meter relay (on assembly on inside of front panel).	If deflection occurs, proceed to step 3. If not, check the monitor selector switch and the meter relay input coil.
3	 Fig. 5-1 or  or 	Remove connectors P2, P3, and P4 and measure continuity across test points. Mark or note original position of relay adjusting screw and then rotate screw in direction of pointer.	Contact opening occurs causing infinite resistance.	If normal indication occurs, return meter adjusting screw to original setting and replace associated connector. This indicates proper protection circuit operation. If normal indication does not occur, check relay meter, relay, and relay power supply.

*Note: Each cable has an internal resistance of 470 ohms.

TABLE 5-5. ANTENNA COUPLER GROUP AN/FRA-49(V),
DIRECTIONAL COUPLER AND ANTENNA COUPLER,
FUNCTIONAL SECTION TROUBLE-SHOOTING CHART

STEP	TEST POINT	PRELIMINARY ACTION	NORMAL INDICATION	NEXT STEP
1		Set the associated monitor selector switch to the VSWR position.	VSWR indication.	Proceed to step 2.
2		Adjust the TUNING and COUPLING controls to obtain a minimum VSWR at the frequency of the associated transmitter.		Proceed to step 3.

TABLE 5-5. ANTENNA COUPLER GROUP AN/FRA-49(V),
DIRECTIONAL COUPLER AND ANTENNA COUPLER,
FUNCTIONAL SECTION TROUBLE-SHOOTING CHART (cont)

STEP	TEST POINT	PRELIMINARY ACTION	NORMAL INDICATION	NEXT STEP
3		Slowly bring the associated transmitter up to the rated power.	No arcing, no operation of the protective circuit, and no VSWR reading greater than 3.5.	If indication is normal, the antenna coupler is operating properly. If indication is not normal, check the protection circuit. Check the tuner gearing. Disconnect the associated transmitter, turn off the blowers. Remove and disassemble the antenna coupler. Check for charred inductor insulators. Remove charred portions or replace. Check for damage to capacitors.

TABLE 5-6. ANTENNA COUPLER GROUP AN/FRA-49(V),
BLOWER CIRCUITS, FUNCTIONAL SECTION
TROUBLE-SHOOTING CHART

STEP	TEST POINT	PRELIMINARY ACTION	NORMAL INDICATION	NEXT STEP
1	<p>Ⓓ</p> <p>Fig 5-2</p> <p>or Ⓔ</p> <p>or Ⓕ</p>	Check BLOWER indicator and a-c power.	Should be on.	If indication is normal, proceed to step 2. If not, check fuses, relay, capacitor, and blower motor.
2		Feel outside air filter for stream of air.	Should be stream of air.	If indication is abnormal, check mechanical fastening between motor and fan blade and check air filter for excessive dirt.

TABLE 5-7. ANTENNA COUPLER GROUP AN/FRA-49(V),
TYPICAL TROUBLES

TROUBLE	NATURE OF TROUBLE	SYMPTOMS
Periodic interruption of transmitter operation.	R-f arcing across the tuning coil in the antenna coupler due to high peak voltages or excessive dirt or moisture; antenna coupler not properly tuned.	Constant tripping of transmitter overload-shutdown circuits.
No signal output at antenna.	Faulty protection circuit operation; excessive VSWR due to mistuning or arcing of antenna coupler; improper adjustment of protection circuit. Open or shorted transmission circuit.	No field strength in area of antenna.

SECTION 6
SERVICE AND REPAIR

6-1. FAILURE REPORT.

Report each failure of the equipment, whether caused by a defective part, wear, improper operation, or an external cause. Use ELECTRONIC FAILURE REPORT form DD787. Each pad of the forms includes full instructions for filling out the forms and forwarding them to the Bureau of Ships. Include the model designation and serial number of the equipment (from the equipment identification plate), the type number and serial number of the major unit (from the major unit identification plate), and the type number and reference designation of the particular defective part (from the technical manual). Describe the cause of the failure completely, continuing on the back of the form if necessary. Don't substitute brevity for clarity. And remember - there are two sides to the failure report -

"YOUR SIDE"

"BUREAU SIDE"

"Every FAILURE REPORT is a boost for you:

"The Bureau of Ships uses the information to:

1. It shows that you are doing your job.
2. It helps make your job easier.
3. It insures available replacements.
4. It gives you a chance to pass your knowledge to every man on the team.

1. Evaluate present equipment.
2. Improve future equipment.
3. Order replacements for stock.
4. Prepare field changes.
5. Publish maintenance data.

Always keep a supply of failure report forms on board. You can get them from the nearest District Publications & Printing Office."

6-2. TUNING AND ADJUSTMENT.

a. All tuning controls are located on the front panel (see figure 6-1). Verify the following conditions before operating the antenna coupler group:

(1) Electrical connections for blower power and remote control relay power are secure and in correct positions (see figure 6-2).

(2) Relay control and protection circuit cables are connected.

(3) The air-circulating blower motor of each antenna coupler functions when the associated transmitter is energized.

(4) The air filter assembly is in place and proper blower operates.

Note

Air intakes and outlets shall be free of obstruction to allow full circulation of air.

b. CONTROL SETTINGS. - The antenna coupler group is operated in accordance with the following tuning procedure and the established settings for TUNING and COUPLING controls. Established settings are previously used settings which have been recorded in pencil on the tuning chart as prescribed in Section 2. All operation controls can be reached on the front panel.

c. TUNING. - To tune a channel to any particular frequency, always consult both the tuning chart located on front panel (see figure 6-1) and tuning graphs (figures 6-3, 6-4, 6-19 and 6-20), which give approximate values. Proceed as follows:

1. Place BLOWER SWITCH in ON position.

CAUTION

Set the COUPLING control of the channel being tuned to 0000 if it is necessary to tune through the frequency of other channels.

2. Turn COUPLING and TUNING knobs to set counter readings to values indicated in the tuning graphs.

3. Set monitor selector switch to VSWR position.

4. Turn on the transmitter (reduced power or tune position).

5. Adjust the TUNING control for minimum VSWR on R. F. INDICATOR meter. Adjust the COUPLING control for minimum VSWR. Retrim both of these adjustments until the lowest possible VSWR is obtained.

6. Apply full transmitter power and recheck VSWR.

7. Set monitor selector switch to FOR position and adjust transmitter power to read 3 kw.

8. Change monitor selector switch to OPR position.

CAUTION

The protection circuit is only in operation when the monitor selector switch is in OPR position. Monitoring of power and VSWR should be limited to brief checks.

6-3. EMERGENCY OPERATION.

Failure of some portions of the antenna coupler group may be remedied by the following emergency procedure.

CAUTION

In general, repairs should be effected as soon as trouble is noted to avoid further damage to the antenna coupler group or other equipment. Emergency suggestions are to be followed only to the extent justified and then only after specific authorization to do so.

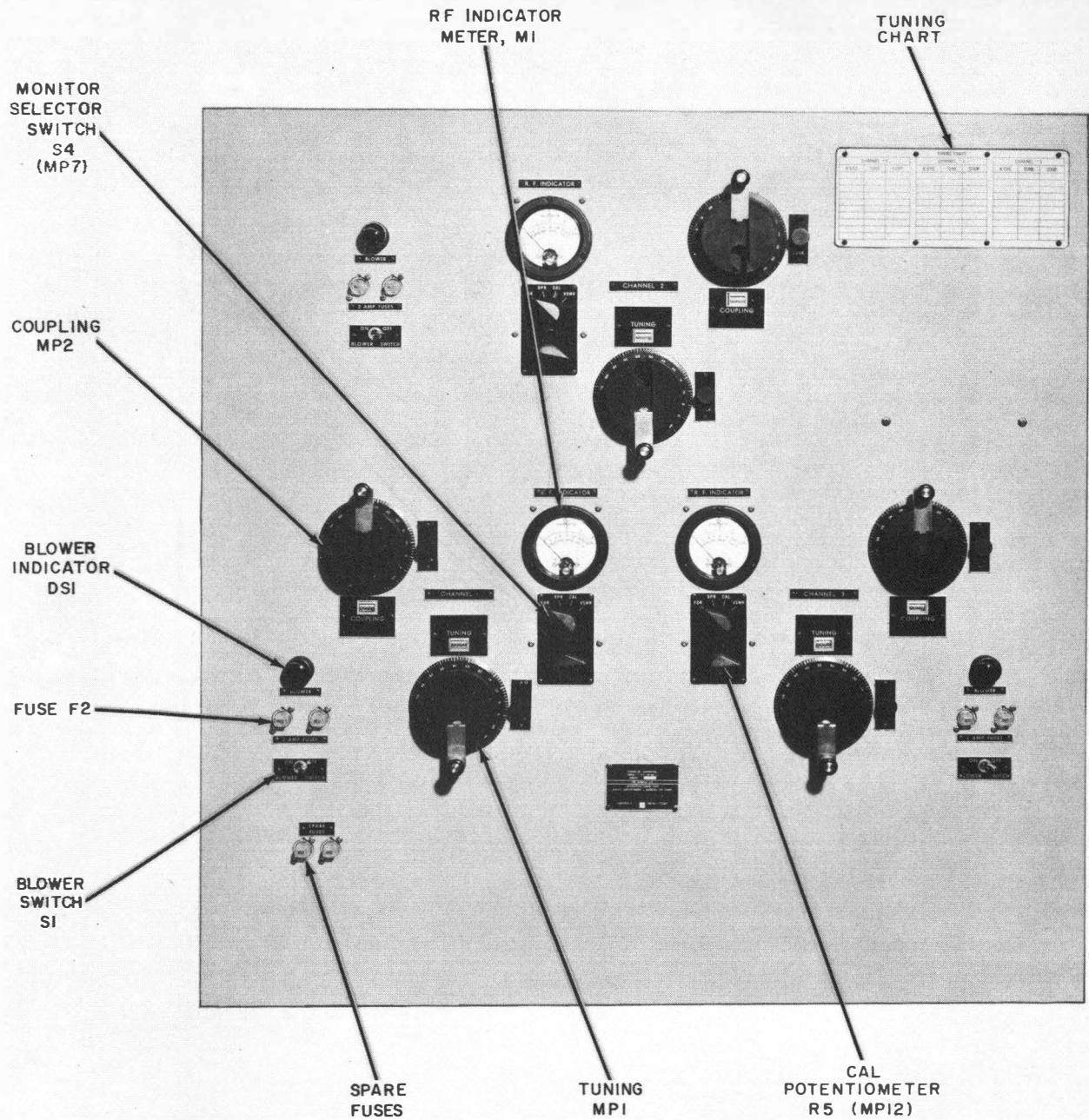

Figure 6-1. Antenna Coupler Group AN/FRA-49(V), Front Panel View

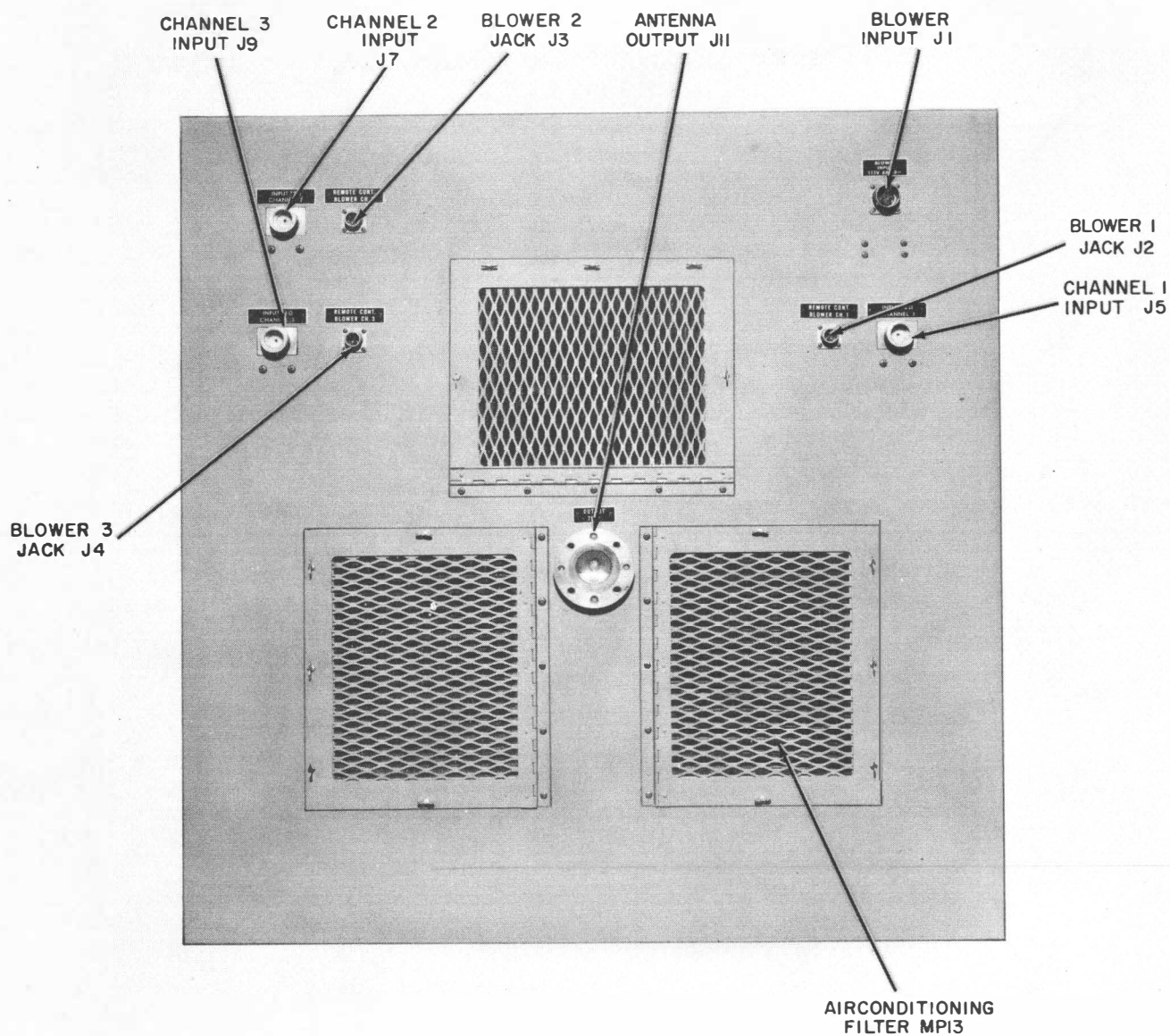

Figure 6-2. Antenna Coupler Group AN/FRA-49(V), Rear Panel Connectors

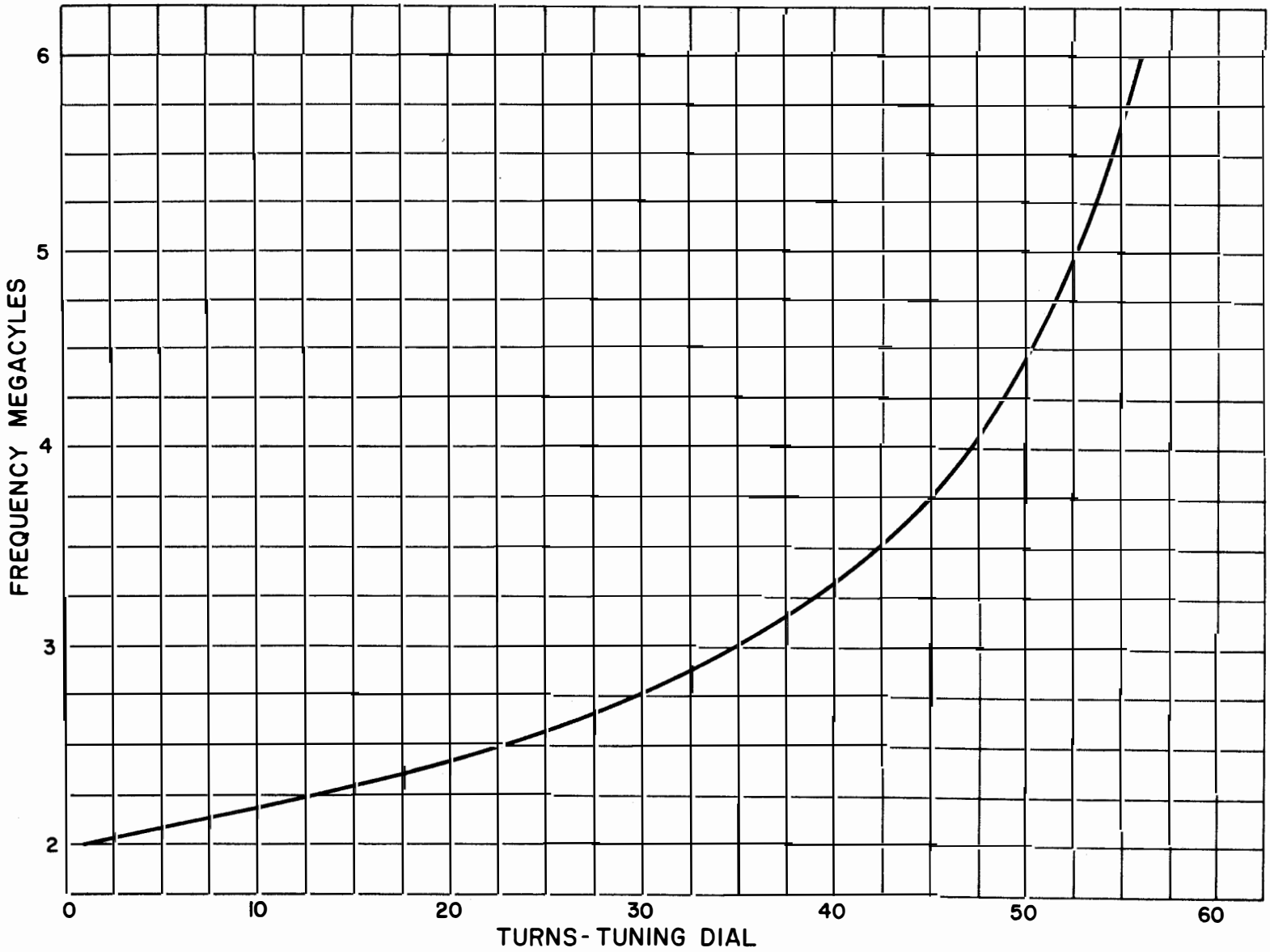

Figure 6-3. Tuning Graph, Antenna Coupler CU-998/FRA-49(V) (2 to 6 mc)



Figure 6-4. Coupling Graph, Antenna Coupler CU-998/FRA-49(V) (2 to 6 mc)

a. Limited operation is possible in the event of a failure in one of the low impedance capacitors. Remove the defective capacitor and retune the antenna coupler group to present a minimum VSWR indication.

b. In the event of failure and removal of an antenna coupler, a shorting bar may be used to permit operation of the other two channels. To bridge an antenna coupler, clamp a shorting bar across the pickup loop connection.

6-4. PREVENTIVE MAINTENANCE OF THE ANTENNA COUPLER GROUP.

The electrical equipment cabinet and equipment should be kept in a state of good repair at all times. The equipment shall also be free of dirt and foreign matter at all times. Proper preventive maintenance reduces the requirements for repair and maintains the proper operating characteristics of the equipment. Wide deviation from the operating characteristics (see figures 6-3 and 6-4 for typical curves) indicates the need for repair. Typical antenna-coupler-group bandpass characteristics, isolation factors and efficiency factors for Antenna Coupler CU-998/FRA-49(V) are given in figures 6-5, 6-6, and 6-7. The tuning and coupling curves for Antenna Coupler CU-999/FRA-49(V) are shown in figures 6-19 and 6-20. Routine or preventive maintenance shall be employed to forestall antenna coupler group breakdown or failure. The operating environment of the equipment shall be considered and the user shall determine the suitable maintenance interval as well as the period of time between maintenance checks. The following are maintenance checks:

CAUTION

~~ing sentence:~~ "Some parts of the antenna couplers are exposed to RF voltages of approximately 55,000 V which create a corona hazard."

gh
nts.
nt
ny

a. CHECK VSWR READING. - The antenna coupler group shall be correctly tuned at all times during operation. Set monitor selector switch to VSWR position for readings and carefully trim with TUNING and COUPLING controls.

b. CHECK MONITOR SELECTOR SWITCH POSITION. - The monitor selector switch for each operating channel shall be kept in OPR (operate) position whenever tuning has been completed. Except for monitoring purposes, the monitor selector switch shall be kept in the OPR position.

A transmitter protection channel check shall be conducted whenever necessary. This check shall be made when it is evident that high values of VSWR do not de-energize the overloaded transmitter(s).

WARNING

R-f voltages dangerous to life are present in the r-f sections of the antenna coupler group.

The uppermost protection meter is for the transmitter on channel 1; the bottom meter is for the transmitter on channel 3. To trip the protection circuit, rotate the center adjusting screw of the meter relay counterclockwise until the pointer touches the fixed contact. Transmitter will be interrupted. Return the pointer to the original position as the protection circuit re-cycles. Repeat this procedure for each operating transmitter. See paragraph 2-4e for calibration of protection circuit.

6-5. REMOVAL OF PARTS.

The removal procedures for parts used in the antenna coupler group are as follows (see figures 6-8 through 6-16):

Note

All removal procedures are performed with the sides and top of the electrical equipment cabinet removed.

a. RELAYS, METERS, COMPONENTS, MOTORS, AND SWITCHES. - Relays, meters, components, motors, and switches are removed by removing the mounting hardware and unsoldering the leads (see figure 6-8).

b. DIRECTIONAL COUPLERS. - Directional couplers are removed by disconnecting all cables and removing the four mounting bolts around the INPUT 75Ω jack. The input jack to the directional coupler is also used as the rear panel jack (see figure 6-9).

c. LOWER ANTENNA COUPLERS. - The procedure for removing the lower antenna couplers (see figure 6-10) is as follows:

- (1) Disconnect both shafts and remove all cables.
- (2) Disconnect the r-f pick-up loop from the antenna junction box.
- (3) Loosen the bolts which hold the yokes of the upper trundle wheels.
- (4) Incline the antenna couplers towards the outside of the electrical equipment cabinet and lift them out.

d. UPPER ANTENNA COUPLER. - The procedure for removing the upper antenna coupler (see figure 6-10) is as follows:

- (1) Disconnect both shafts and remove all cables.
- (2) Disconnect the r-f pick-up loop from the antenna junction box.
- (3) Unfasten the bolts holding one end of each guide-track retainer and swing the two retainers up so as to disengage both trundle wheels.

Note

Removal of center frame member will aid in removal of the upper antenna coupler (see figure 6-10).

(4) Lift the antenna coupler out of the electrical equipment cabinet.

e. SMALL TUNING CAPACITORS. - The small tuning capacitors (see figure 6-11) are removed as follows:

- (1) Gain access to the capacitor through the cutouts in the front of the antenna coupler.
- (2) Remove the butterfly nut and the two halves of the shaft-coupler.
- (3) Remove the retaining clamp.
- (4) Disengage the capacitor from its socket and lift out.

f. LARGE TUNING CAPACITOR. - The large tuning capacitor can only be removed when the antenna coupler is removed from the electrical equipment cabinet. The procedure (see figures 6-12 and 6-13) is as follows:

- (1) Remove the associated antenna coupler and stand it with gears uppermost.
- (2) Note the position of the front trundle-wheel assemblies and remove the 12 mounting screws, lock-washers, nuts, and two trundle-wheel assemblies from the circumference of the upper flange.
- (3) Lift the gear housing assembly up and off

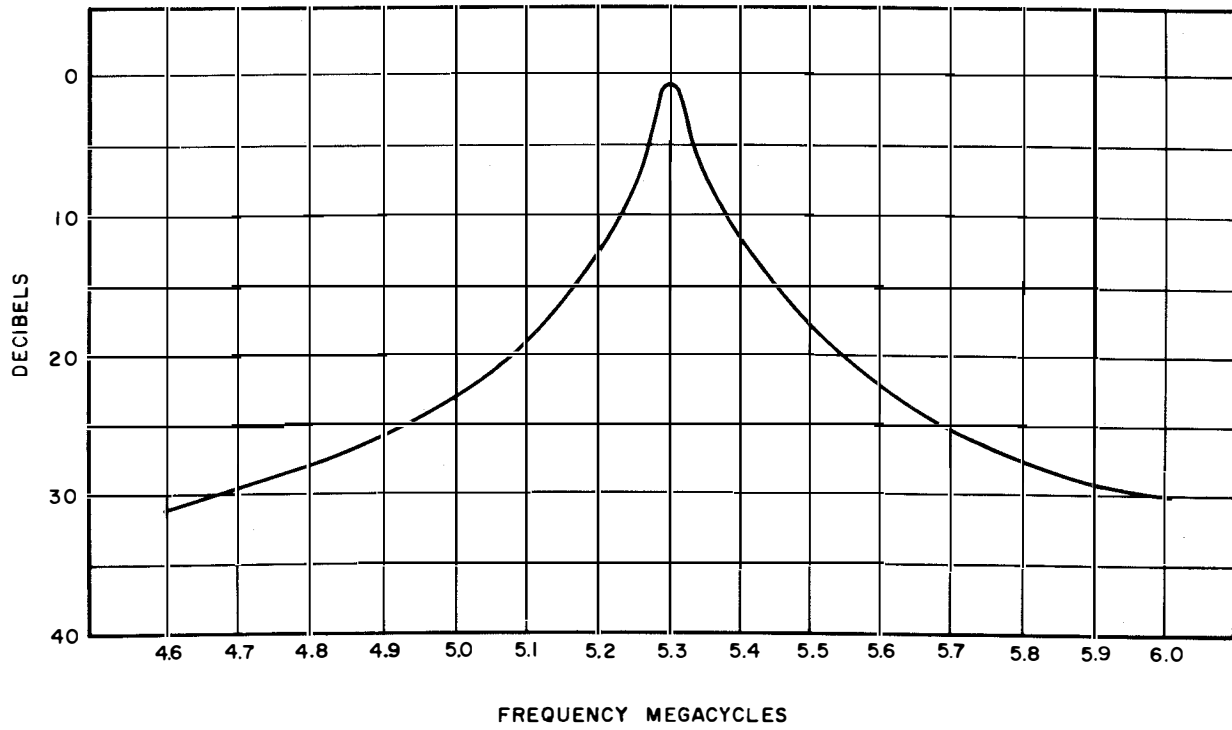

Figure 6-5. Typical Bandpass Response Curve For Antenna Coupler Group

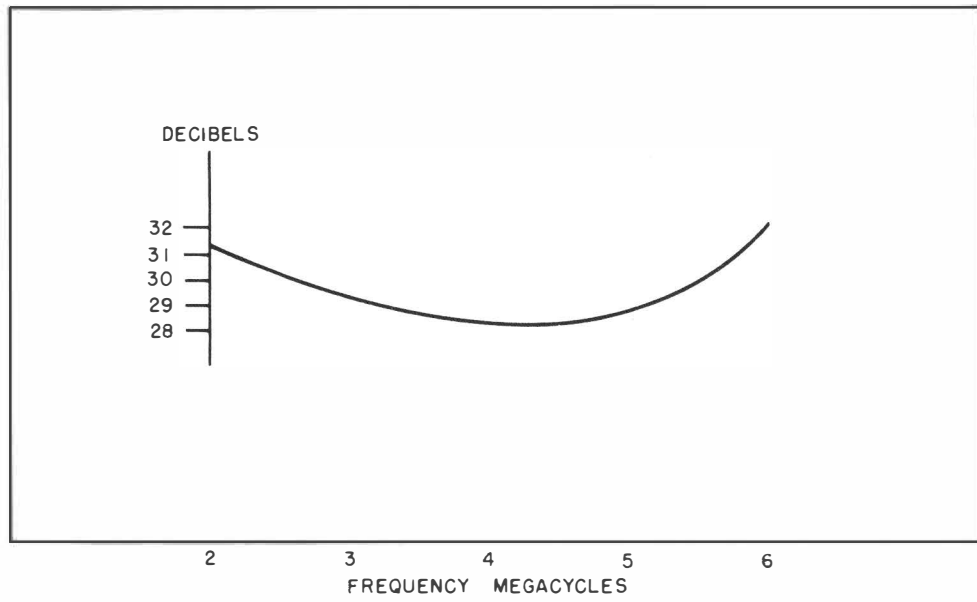

Figure 6-6. Typical Channel Isolation Factors For Antenna Coupler Group

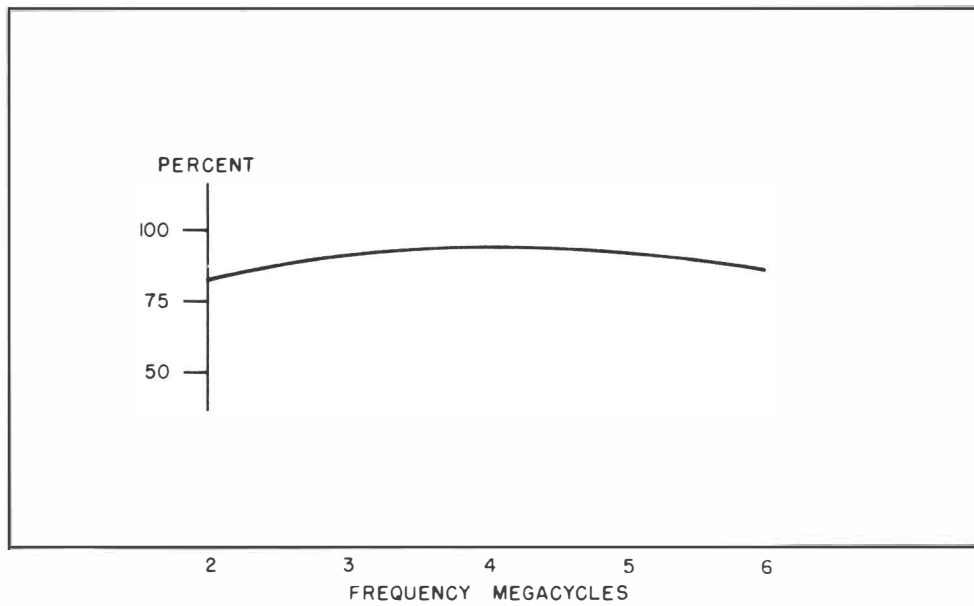

Figure 6-7. Typical Efficiency Factors For Antenna Coupler Group

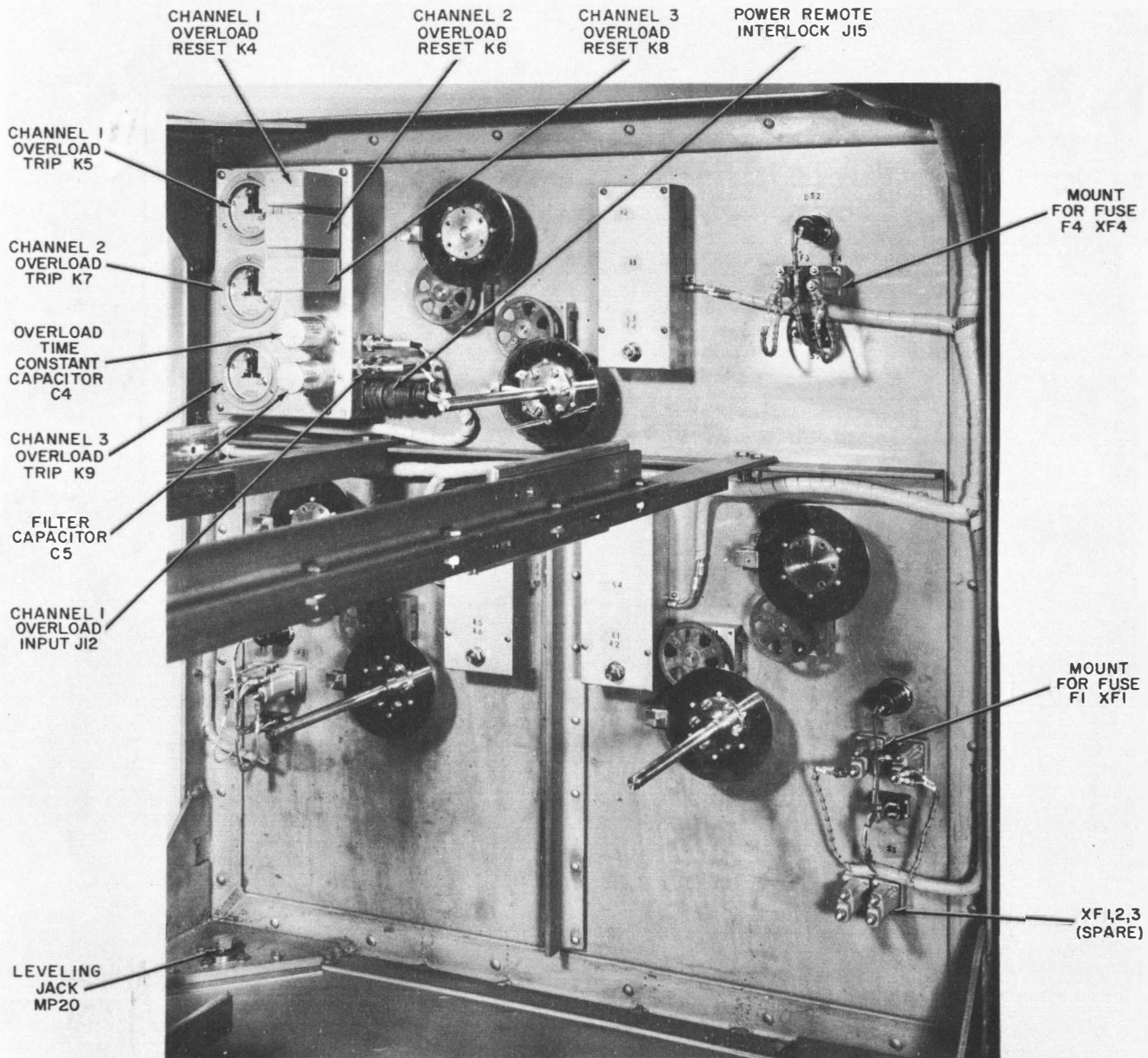

Figure 6-8. Electrical Equipment Cabinet CY-3409/FRA-49(V),
Inside Front Panel (tuners removed)

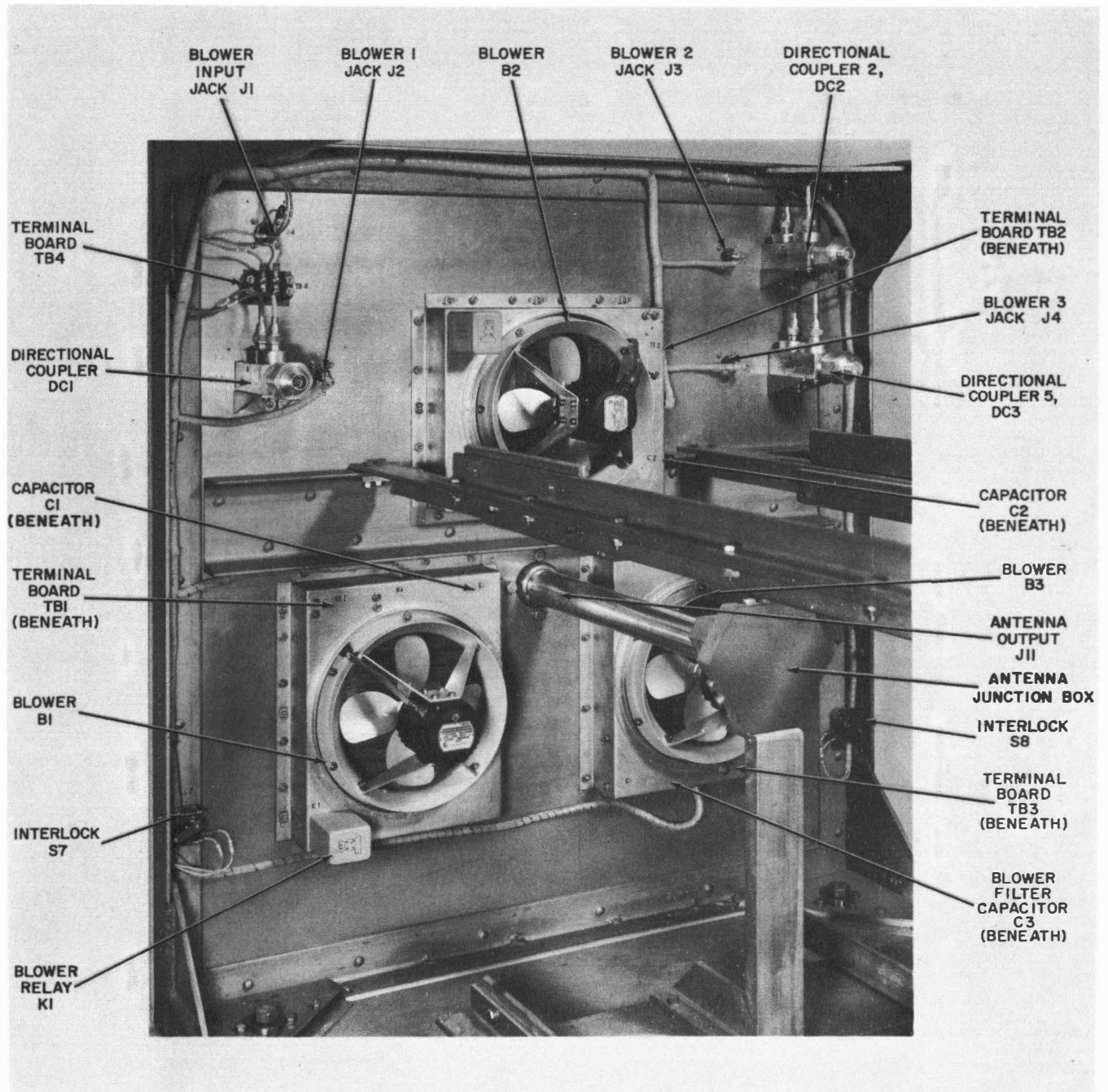

Figure 6-9. Electrical Equipment Cabinet CY-3409/FRA-49(V),
Inside Rear Panel (tuners removed)

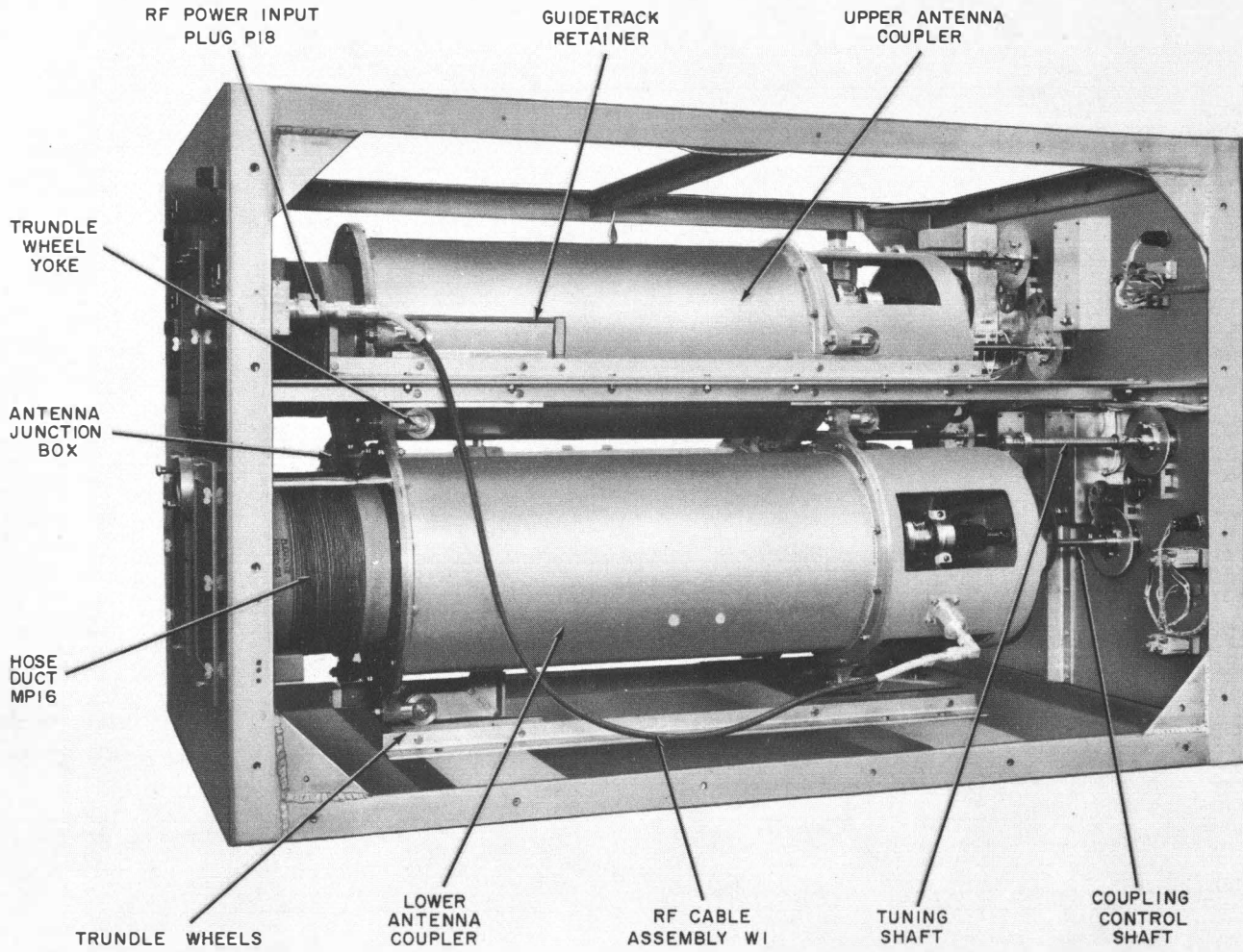

Figure 6-10. Electrical Equipment Cabinet CY-3409/FRA-49(V),
Left Rear Oblique View

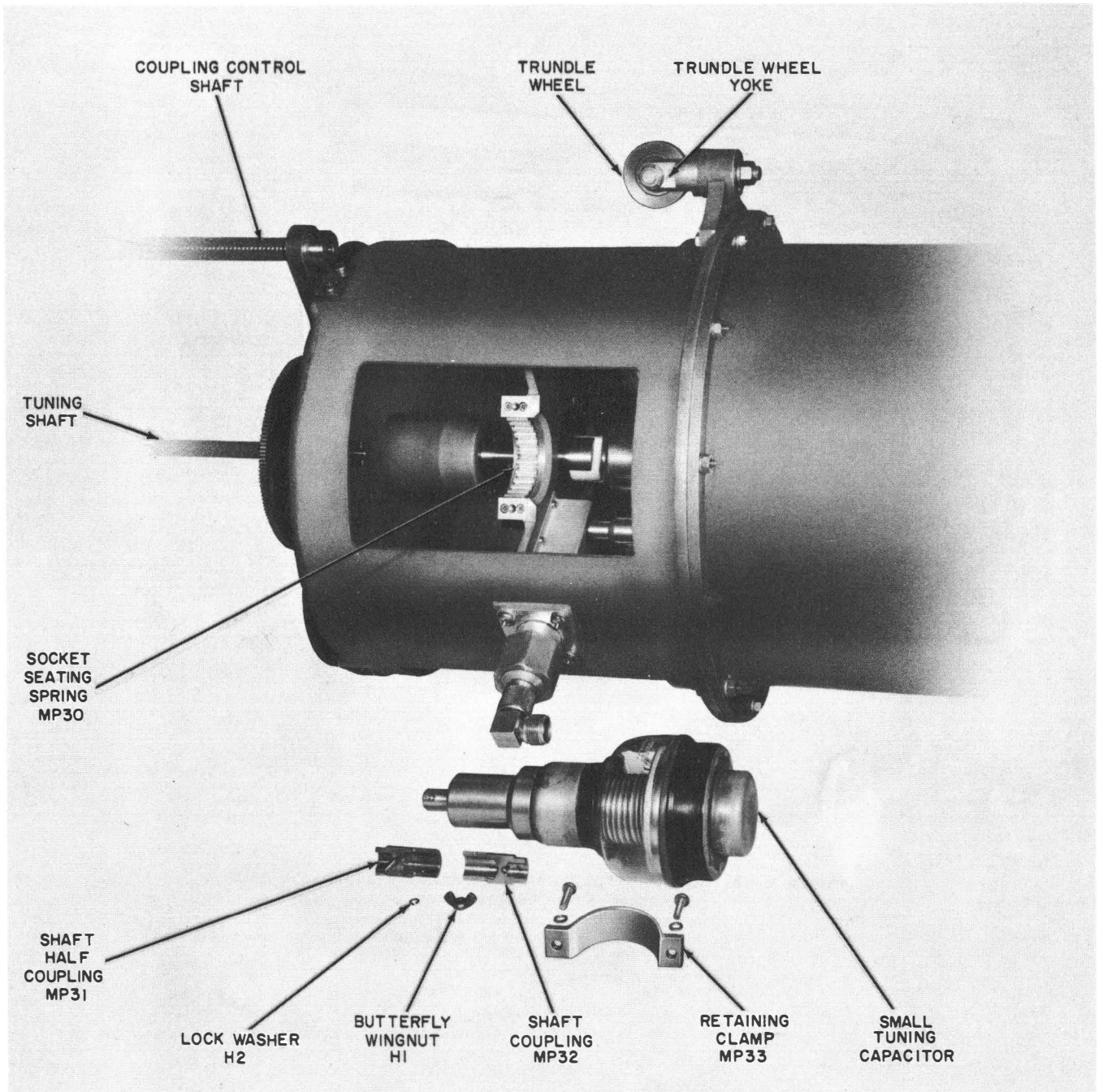

Figure 6-11. Antenna Coupler, Small Capacitor Removed

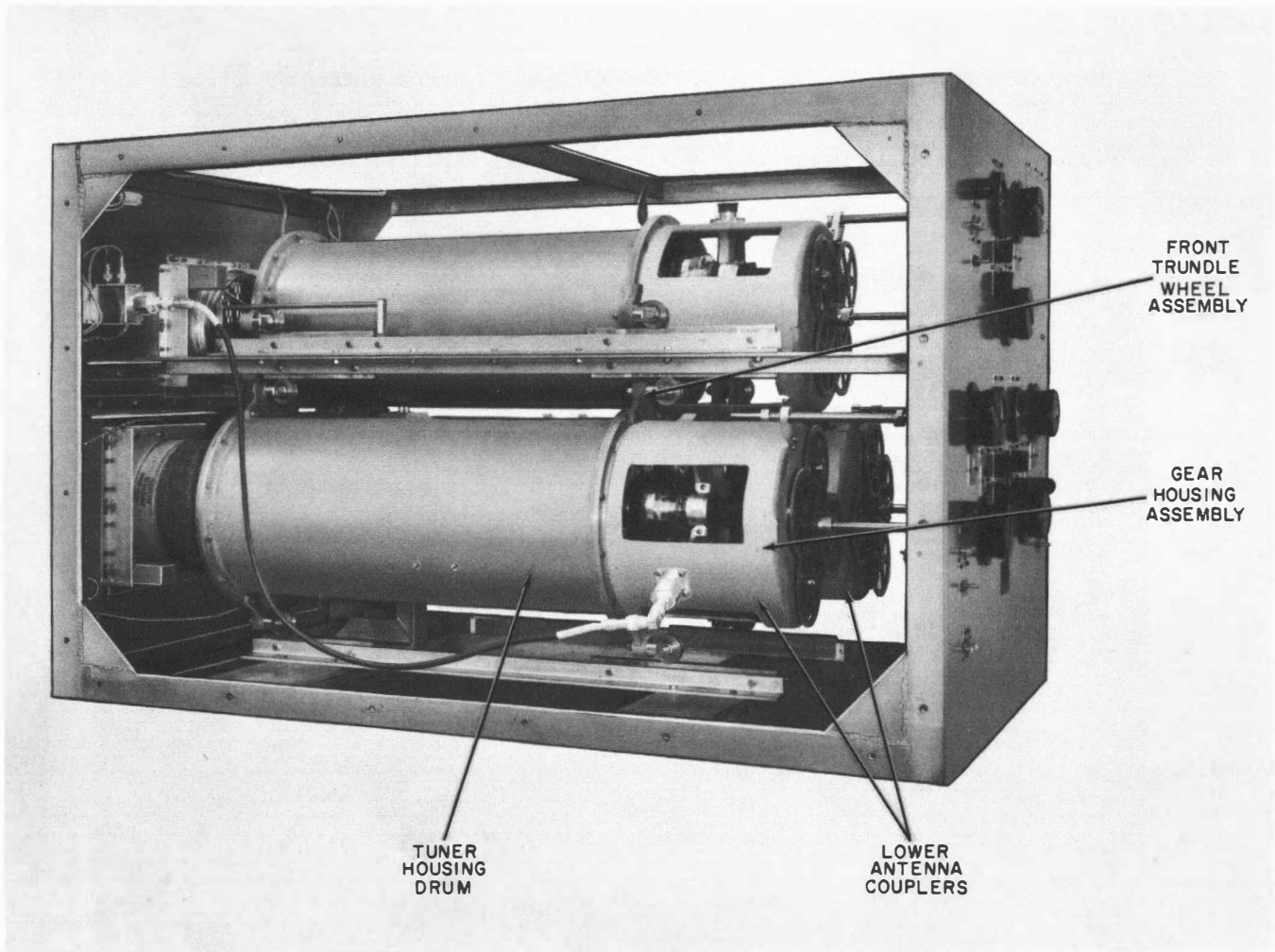

Figure 6-12. Electrical Equipment Cabinet CY-3409/FRA-49(V),
Left Front Oblique View

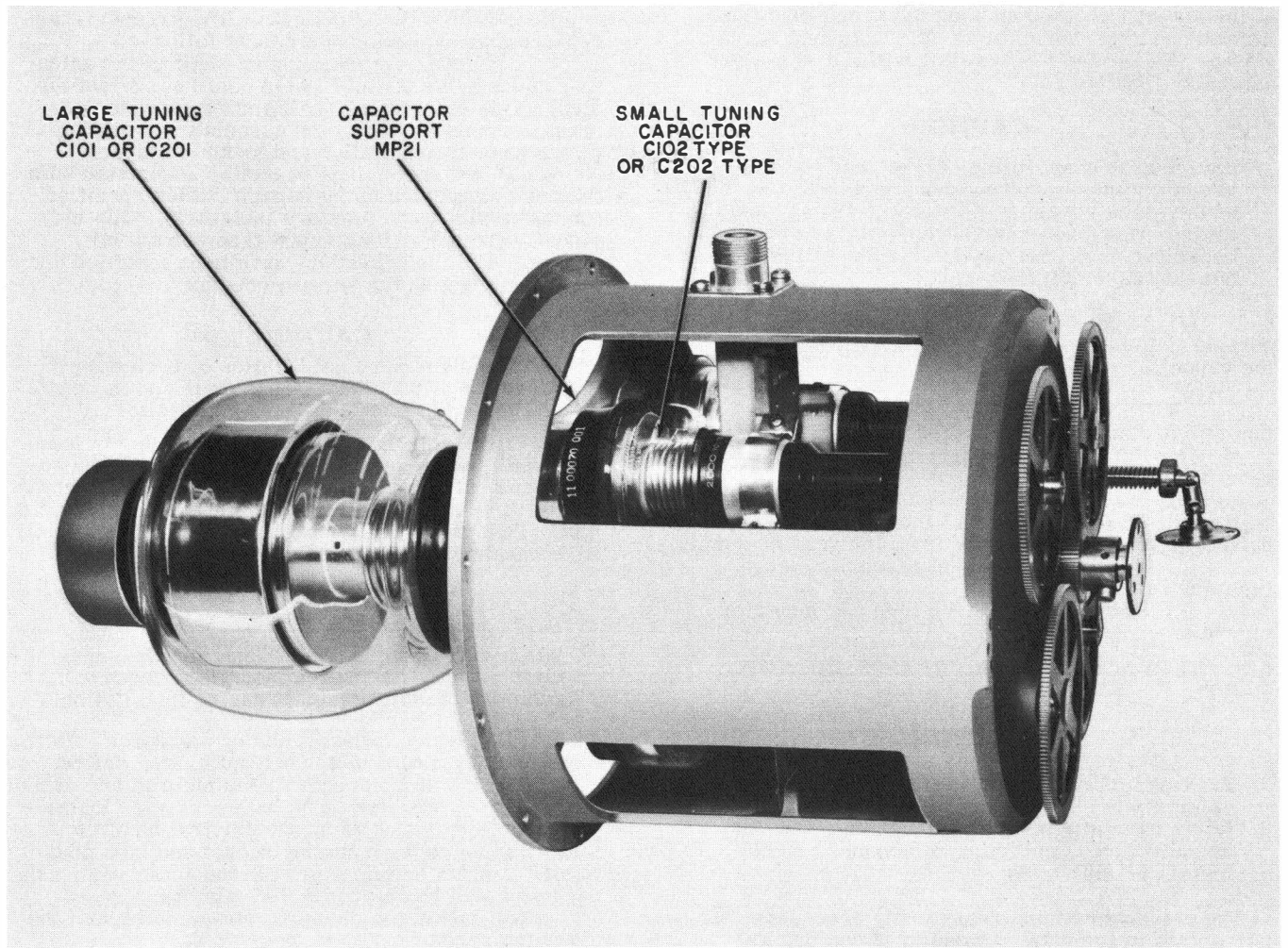

Figure 6-13. Antenna Coupler, Gear Housing Assembly

of the antenna coupler housing drum and place it on its side. Large capacitor is held in by one screw and clamp. Take care so capacitor will not slip when assembly is lifted out.

CAUTION

See T-2

Side motion when lifting off the gear housing assembly may result in shock and breakage of the glass envelope of the large tuning capacitor. This will occur because the end of the capacitor protrudes beyond the end of the gear housing assembly.

(4) Loosen the retaining clamp on the lower portion of the gear housing assembly and slowly pull the capacitor out of the clamp.

g. TUNING INDUCTOR. - Removal of the tuning inductor is accomplished as follows:

- (1) Remove the antenna coupler (see steps 6-5c and 6-5d).
- (2) Place the antenna coupler housing drum on its side and remove the 12 mounting bolts and hardware from the end away from the gear assembly.
- (3) Pull out the coil subassembly (see figure 6-14).
- (4) Remove r-f pick-up loop and insulator sleeve (see figure 6-15).

6-6. REPLACEMENT AND REASSEMBLY OF PARTS.

CAUTION

See T-1

All parts of antenna couplers exposed to high voltage must be clean and free of fingerprints. Clean carefully before replacement. Do not use abrasives, polishing compounds, or any metal cleaning tools.

The replacement and reassembly procedures for parts used in the antenna coupler group are as follows (see figures 6-8 through 6-16):

- a. TEST EQUIPMENT. - Use a General Radio Type 1611-B Capacitance Bridge or equivalent to perform the tuning capacitor adjustments.
- b. RELAYS, METERS, COMPONENTS, MOTORS AND SWITCHES. - The replacement and reassembly procedures for these items consist of remounting and resoldering.
- c. DIRECTIONAL COUPLERS. - Replace directional coupler by remounting and reconnecting all cables (see figure 6-13). Determine calibration by making comparison check against known standard.

d. ANTENNA COUPLER. - The procedure for replacing an antenna coupler is as follows:

- (1) Rotate the main tuning shaft of the antenna coupler to its full clockwise position against the stop. This main tuning shaft setting must then remain unchanged until all the associated tuning capacitors have been installed and locked in place.
- (2) Set each tuning capacitor associated with the antenna coupler to the capacity value specified for that tuning capacitor (see table 6-1). The individual capacitor settings must then remain unchanged until the capacitors have been installed and locked in place in the antenna coupler.

CAUTION

Make certain that final location of each tuning capacitor in the antenna coupler is known before attempting to install the tuning capacitors.

(3) Install the large tuning capacitor by sliding it into place exactly along the shaft axis and rotating the entire capacitor without changing its capacity setting until the shaft pin mates with the coupling slot. Push the capacitor all the way in and then pull back one-sixteenth of an inch (see figure 6-13).

CAUTION

Failure to adhere to proper capacitor installation may result in total damage to the capacitor. Check for proper mounting pressure and possible misalignment during installation.

- (4) Tighten the large tuning capacitor within its clamps by means of round head slotted screw.
- (5) Install a spring take-up shim in one of the small tuning capacitor clamping recesses. Install the associated tuning capacitor for that position by inserting it into the mounting socket and then positioning it to its mating shaft. In the final position the capacitor will be resting in its clamping recess.
- (6) Install the clamping strap and tighten the clamping screws.
- (7) Grasp capacitor by the bulb portion and with a moderate twist attempt to turn it. If the tuning capacitor does not turn the mounting pressure is correct. If the tuning capacitor does turn it will be necessary to remove the capacitor.
- (8) Install another take-up shim directly over the first shim and re-install the capacitor by rotating the entire capacitor without changing its capacity setting for proper pin alignment.
- (9) Replace the mounting strap and tighten the screws only to the tension required to mount the tuning capacitor firmly.
- (10) Install the split shaft coupling assembly.
- (11) Tighten the locking wing nut on the split shaft assembly.

TABLE 6-1. TUNING CAPACITOR INSTALLATION SETTINGS*

CU-998/FRA-49(V)			CU-999/FRA-49(V)		
CAPACITOR SYMBOL**	CAPACITOR NUMBER	REQUIRED SETTING	CAPACITOR SYMBOL**	CAPACITOR NUMBER	REQUIRED SETTING
C101	11-00069-001	43uuf	C201	11-00069-002	27uuf
C102	11-00070-001	250uuf	C202	11-00070-002	100uuf 100uuf
C103	"	"	C203	"	"
C104	"	"	C204	"	"
C105	"	"			

* Main tuning shaft is full clockwise against the stops.

** C101 and C201 rotate clockwise to minimum capacity. Remaining tuning capacitors rotate counterclockwise to minimum capacity.

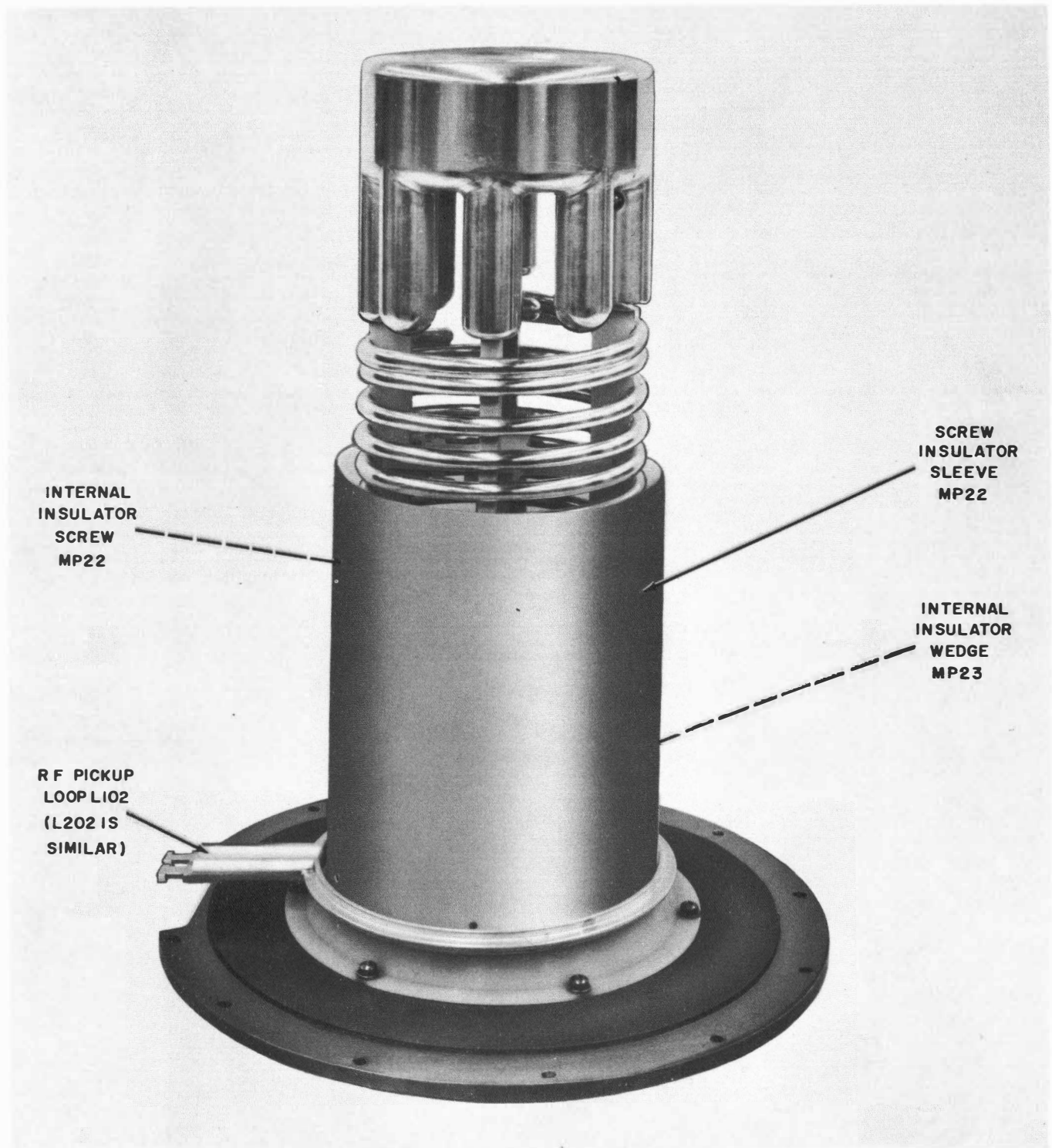

Figure 6-14. Coil Subassembly, With Pickup Loop

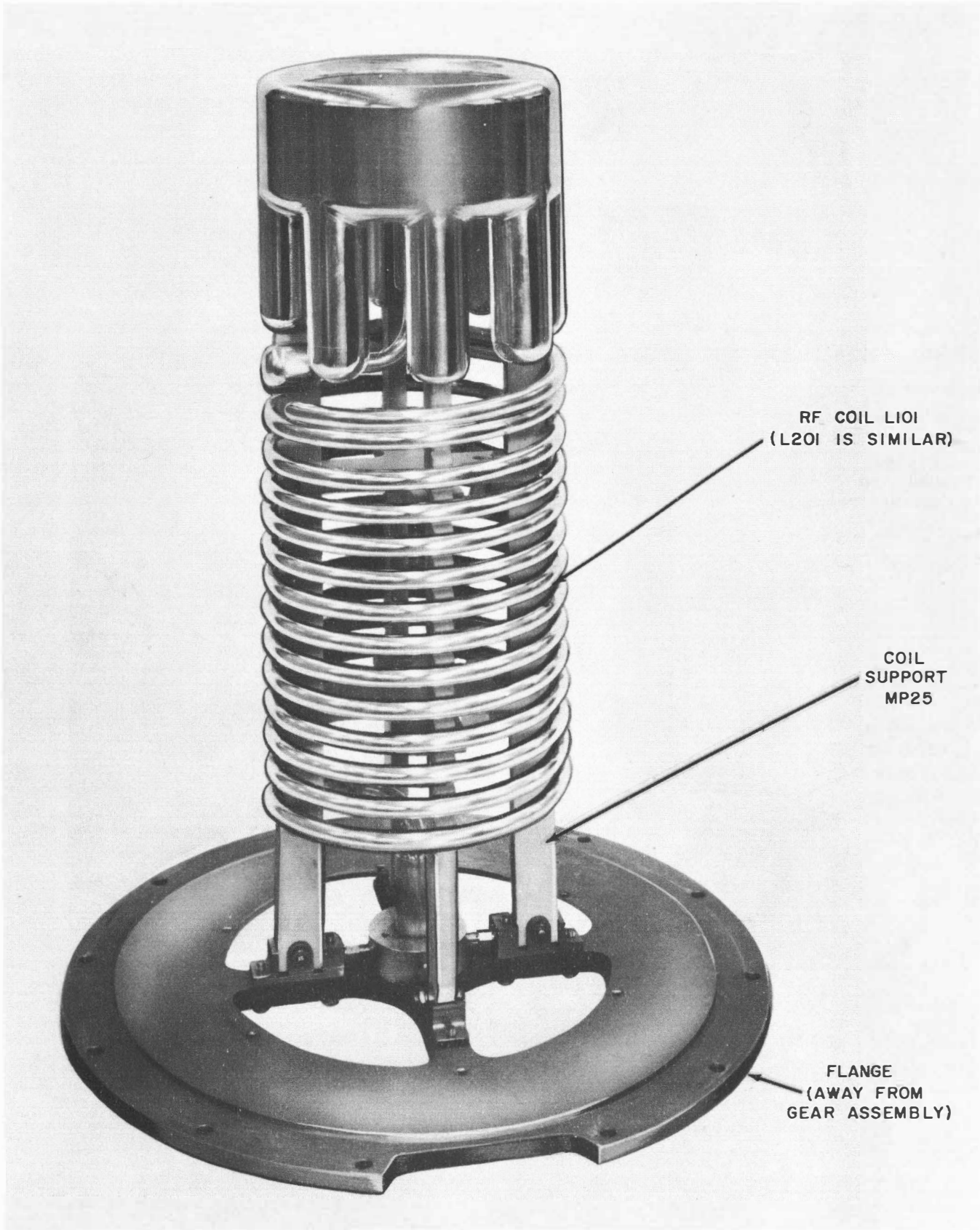

Figure 6-15. Coil Subassembly, Pickup Loop Removed

(12) Repeat steps five through 11 for the remaining capacitors.

(13) Rotate the main tuning shaft and the coupling shaft of the antenna coupler to their full counter-clockwise positions against the stops. The settings of the two shafts must then remain unchanged until the antenna coupler is installed and locked in place in the electrical equipment cabinet.

Note

Installation of an antenna coupler to a channel location in the electrical equipment cabinet for which the antenna coupler was not originally intended may be performed. If such is the case it shall be necessary to remove the trundle wheel assemblies and the coupling shaft assembly from the antenna coupler and re-install them. The pick-up loop slot on the drum may be used as an alignment guide to determine the orientation and position of the trundle wheels and coupling shaft assembly.

CAUTION

An antenna coupler is heavy. Three men shall be required to lift the antenna coupler into position in the electrical equipment cabinet. An upper antenna coupler shall be placed into position from the top of the electrical equipment cabinet.

(14) Position the antenna coupler so that the pick-up loop projecting from the antenna coupler is to the rear of junction box and the main tuning shaft and the coupling shaft are concentric with their respective control discs on the rear of the front panel of the electrical equipment cabinet. When this alignment is complete tighten the trundle-wheel assemblies to the drum securely.

(15) Set the TUNING and COUPLING controls on the front panel to 0000 and lock.

(16) Inspect the alignment of the mounting holes on the coupling shaft in respect to the holes on the coupling disc on the front panel rear. If the holes are in alignment insert the three mounting screws and tighten. If the holes are not in alignment rotate the coupling shaft no more than 60 degrees clockwise until the next set of holes lines up. Insert mounting screws and tighten.

(17) Install air duct assembly.

(18) Unlock the COUPLING control and rotate the control clockwise to move the antenna coupler to the rear of the electrical equipment cabinet so that the main tuning shaft may be connected to the front panel.

(19) Use the method specified in step 16 and connect the main tuning shaft to the front panel control.

(20) Connect the pick-up loop to the antenna junction box (figure 6-9).

(21) The remaining connections will be self-evident.

e. TUNING INDUCTOR. - Replace the tuning inductor as follows:

(1) Fasten the coil subassembly to the antenna coupler housing drum (see figure 6-16). Check to see that pick-up coil L102 or L202 is in place and correctly positioned.

(2) Reassemble the antenna coupler as described in steps one through four of paragraph 6-5g.

(3) Install the antenna coupler in the electrical equipment cabinet as described in steps 13 through 20.

6-7. ADJUSTMENTS.

Adjustments are to be made whenever:

- a. Tuning capacitors or inductors are replaced.
- b. Meter relays are replaced.
- c. Meter potentiometers are replaced.
- d. Directional couplers are replaced.

Adjust the associated antenna coupler when tuning elements are replaced. Repeat original set-up procedures to ensure proper capacity settings.

Adjust the meter relay when it is replaced. Use the procedure given in Section 2.

Calibrate the R. F. INDICATOR METER for VSWR whenever the CAL potentiometer is replaced. Use the procedure given in Section 2.

Adjust the FOR potentiometer whenever it is replaced. Do this by applying a known power to the associated channel and adjusting the FOR potentiometer until that power is indicated on the R. F. INDICATOR meter.

Adjust the meter relay and the CAL potentiometer whenever the directional coupler is changed. Use the procedures given in Section 2.

6-8. WIRING AND SCHEMATIC DIAGRAMS.

The wiring diagram and the schematic diagram for Antenna Coupler Group AN/FRA-49(V) are presented in figures 6-17 and 6-18.

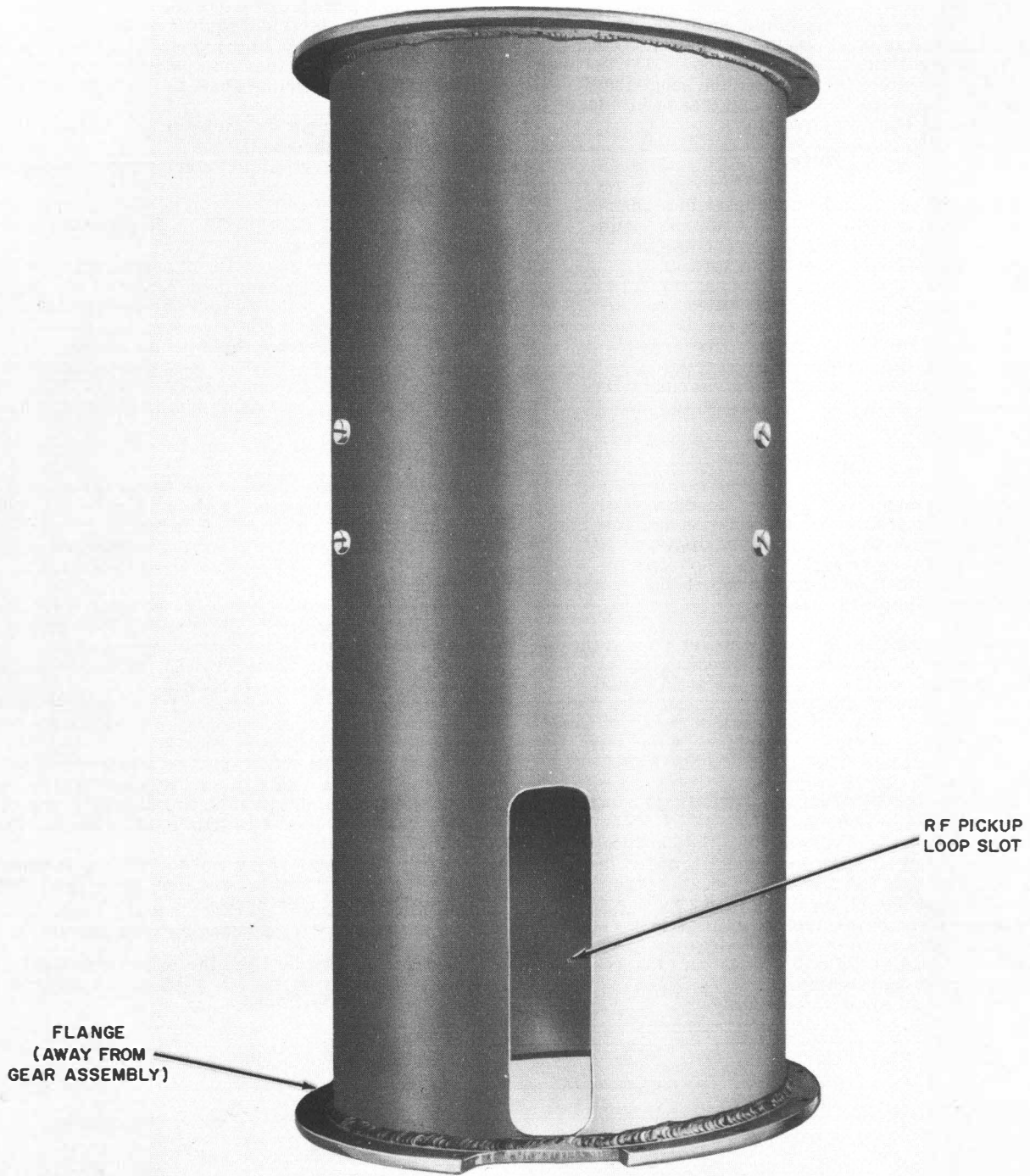

Figure 6-16. Antenna Coupler Tuner Housing Drum

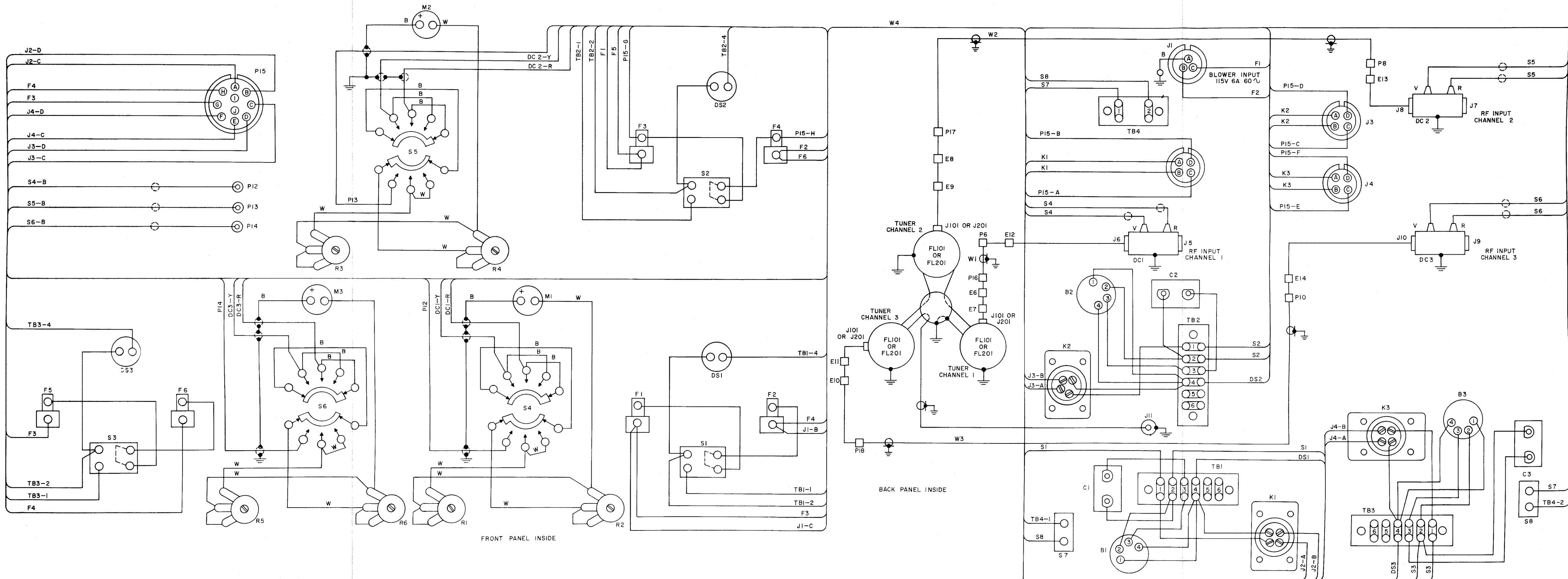

Figure 6-17. Antenna Coupler Group AN/FRA-49(V), Wiring Diagram (Sheet 1 of 2)

ORIGINAL

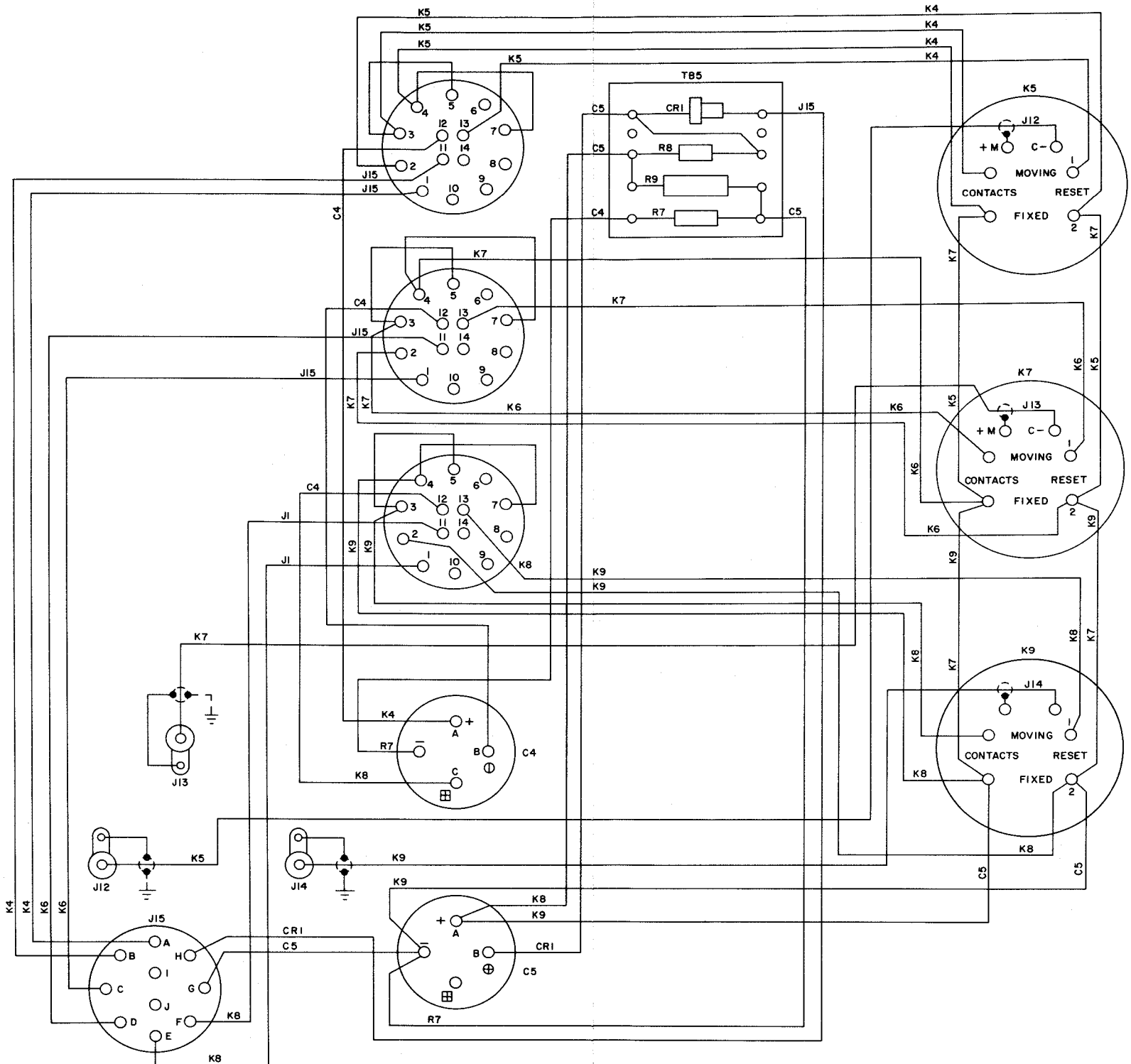

Figure 6-17. Antenna Coupler Group AN/FRA-49(V), Wiring Diagram (Sheet 2 of 2)

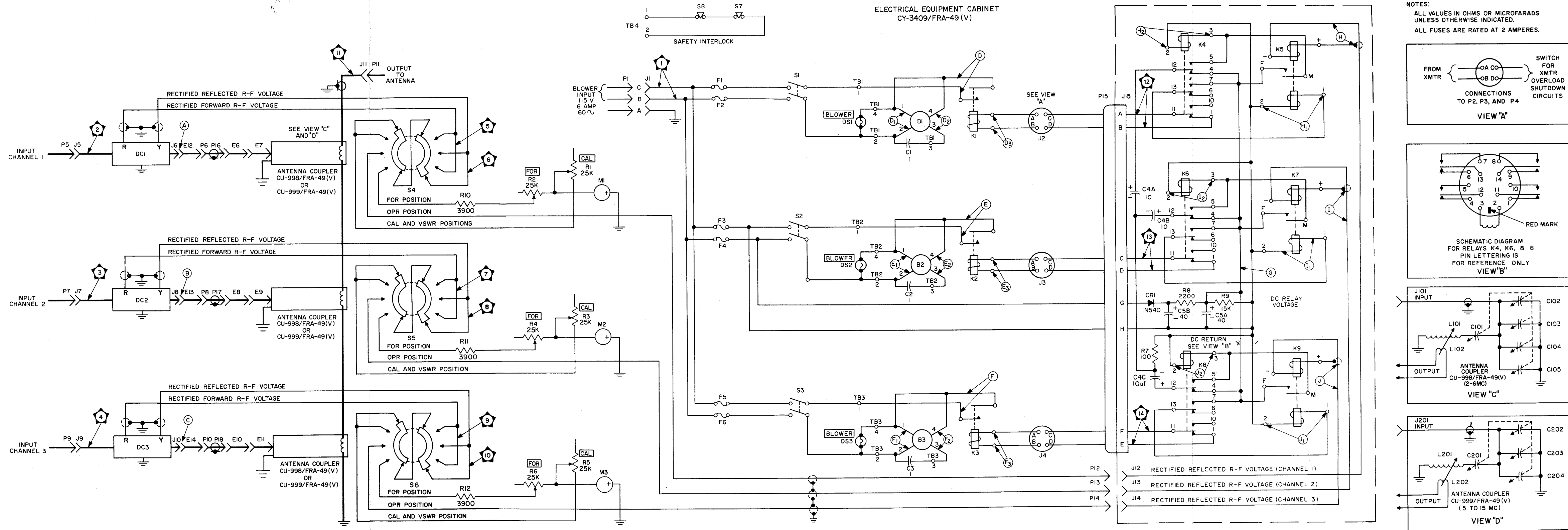

Figure 6-18. Antenna Coupler Group AN/FRA-49(V), Schematic Diagram

ORIGINAL

6-23/6-24

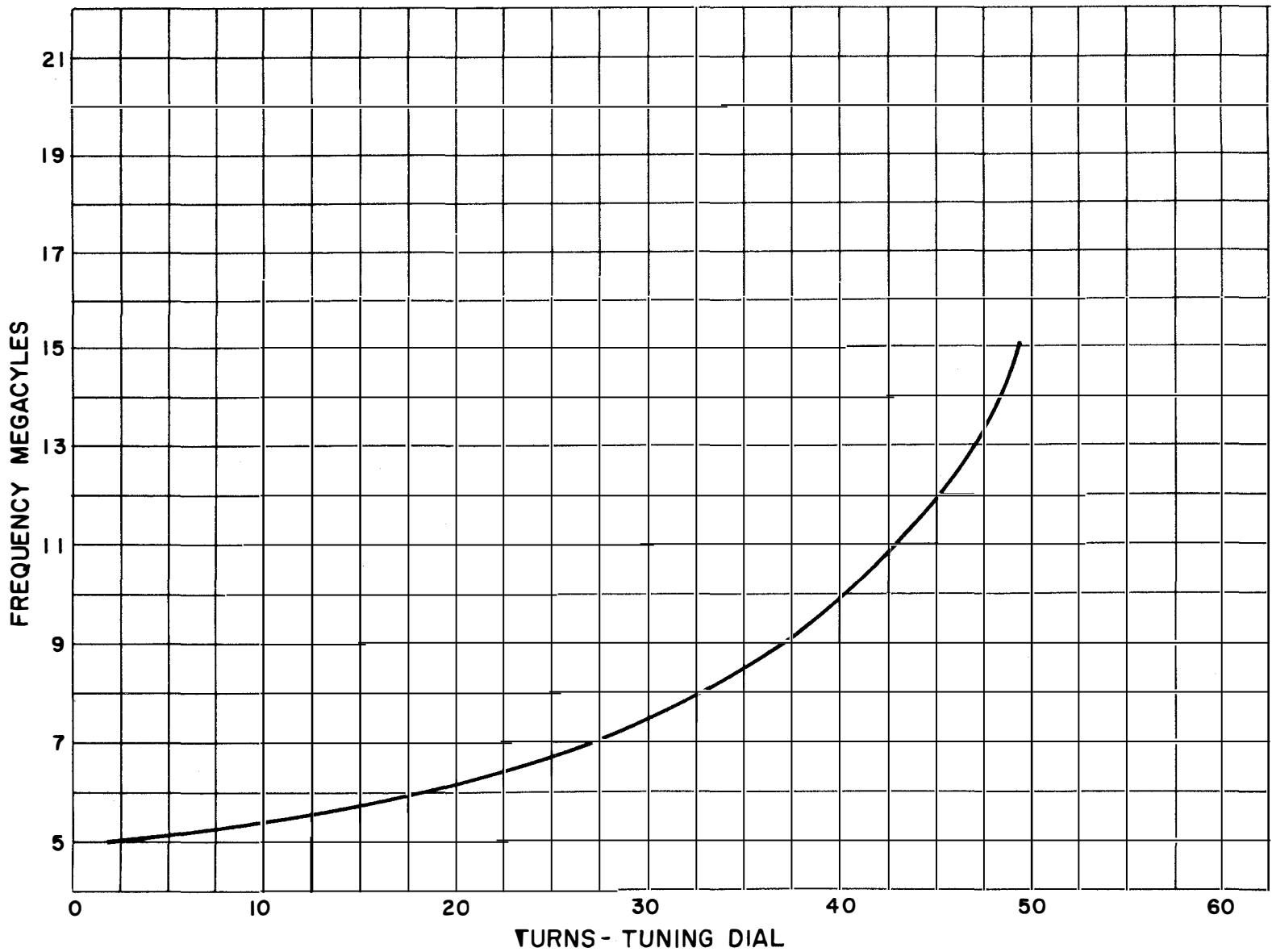

Figure 6-19. Tuning Graph, Antenna Coupler CU-999/FRA-49(V) (5-15 mc)

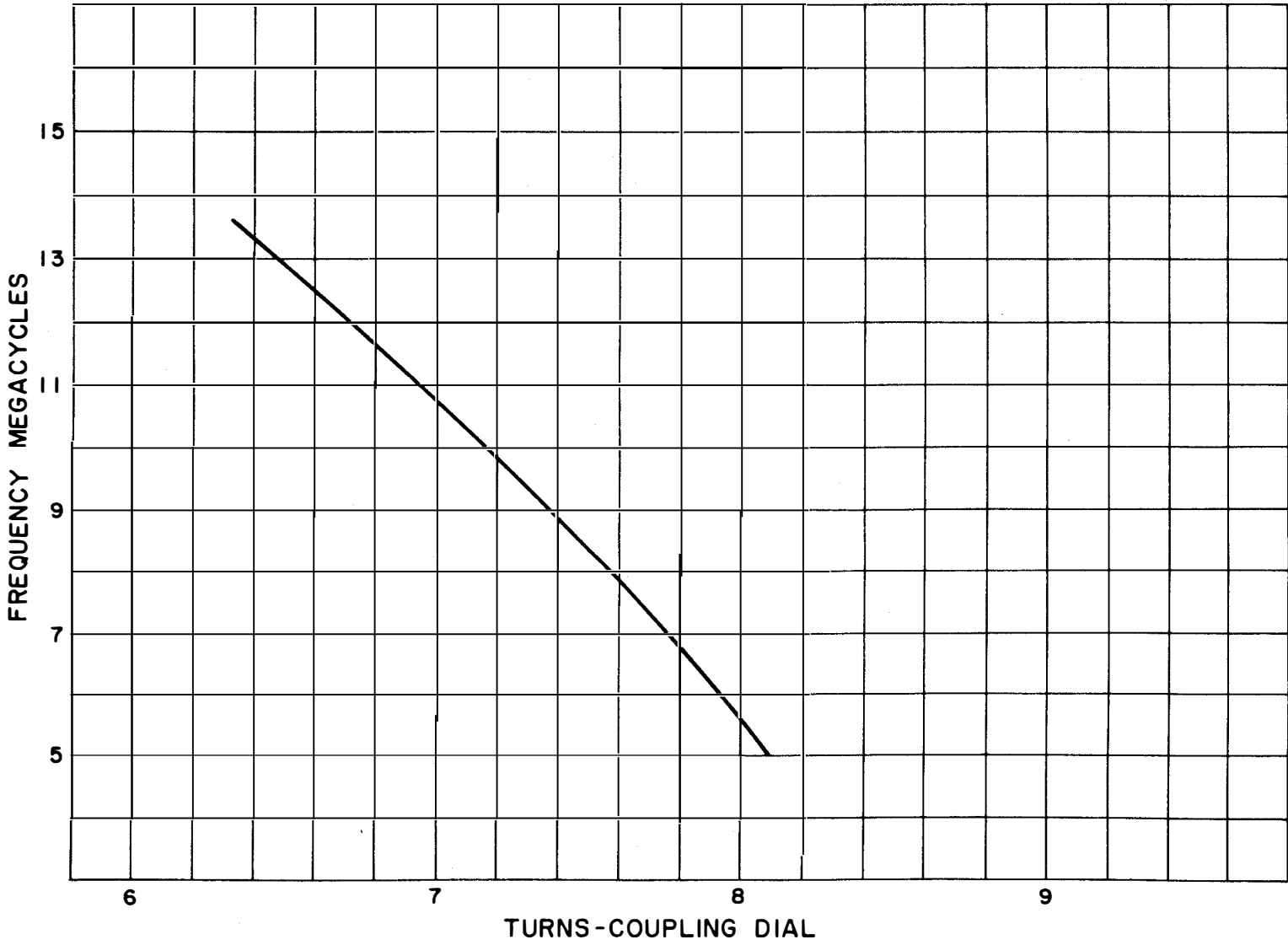

Figure 6-20. Coupling Graph, Antenna Coupler CU-999/FRA-49(V) (5-15 mc)

SECTION 7

PARTS LIST

7-1. INTRODUCTION.

Reference designations have been assigned to identify all maintenance parts of the equipment. These designations are marked on the equipment (adjacent to the parts list. The prefix letter (s) of a reference designation indicate the kind of part such as (R) resistor, (C) capacitor, (CR) crystal rectifier. The number differentiates between parts of the same kind in various areas of the equipment. The series of numbers from 1 thru 99 is used for components which are used in Electrical Equipment Cabinet CY-3409/FRA-49 (V). The 100 series of numbers is used for components used in Antenna Coupler CU-998/FRA-49 (V). The 200 series is used for components used in Antenna Coupler CU-999/FRA-49 (V).

7-2. MAINTENANCE PARTS LIST.

Table 7-1 lists the major equipment and its maintenance parts. Column 1 lists the reference series of the major equipment, followed by the reference designations of the various parts in alpha-numerical

order. Column 2 provides for applicable notes that may be added in a later revision. Column 3 indicates the description of the various parts. A description is presented for all parts listed for the first time (key parts). Subsequent listing of an item previously indicated as a key part will be identified by the phrase "Same as" and the key part reference designation.

7-3. LIST OF MANUFACTURERS.

Table 7-2 lists the manufacturers of parts used in the equipment. The first column includes the abbreviations used in table 7-1 to identify these manufacturers.

7-4. STOCK NUMBER IDENTIFICATION.

Stock Number Identification Tables (SNIT) or Allowance Parts List (APL) issued by the Electronics Supply Office include Federal Stock Numbers and Source Maintenance and Recoverability Codes. Therefore, references shall be made to the appropriate SNIT or APL for this information.

TABLE 7-1. ANTENNA COUPLER GROUP AN/FRA-49(V),
MAINTENANCE PARTS LIST

REF. DESIG.	NOTES	NAME AND DESCRIPTION	FUNCTION
Series 1 thru 99, 100 thru 199, 200 thru 299		ANTENNA COUPLER GROUP AN/FRA-49 (V): link coupling; 2 to 6 mc frequency range or 5 to 15 mc frequency range; variable capacitor tuned; three 3 kw, 100 percent amplitude modulated transmitters; or three 10W, single sideband transmitters; provide maximum power capacity; operating power requirement, AC, 115V \pm 10 percent, 50/60 cycle, one phase; 75 ohm input, 75 ohm output; 4 coaxial connectors located in rear; 63 in. lg, 36-1/2 in. w, 37-1/4 in. h over-all; case painted light gray enamel per spec MIL-E-15090; Navy Bu Ships spec SHIPS-A-2900; ECI part/dwg 01-00006-000	
Series 1 thru 99		CABINET, ELECTRICAL EQUIPMENT CY-3409/FRA-49 (V)	
B1		FAN, AXIAL, 115V, 50-60 CPS: Enclosure: for cabinet mounting; 4 blades, aluminum, approximately 7 in. dia; 52 w full load rating, 115V \pm 10%, 50/60 cycle, one phase; direct drive; cw rotation; shipboard or shore installation; w/fan guard; 8-1/2 in. dia, 5-1/16 in. deep over-all; 320 CFM rated air delivery; Mfg Rotron Model NF, type KS6501, flow R, series 91AS, ECI part/dwg 59-0001-000	Air cooling, Blower, Channel 1; Figure 6-9
B2		SAME AS B1	Air cooling, Blower Channel 2; Figure 6-9
B3		SAME AS B1	Air cooling, Blower, Channel 3; Figure 6-9

TABLE 7-1. ANTENNA COUPLER GROUP AN/FRA-49 (V)
MAINTENANCE PARTS LIST (cont)

REF. DESIG.	NOTES	NAME AND DESCRIPTION	FUNCTION
C1		CAPACITOR, FIXED, PAPER DIELECTRIC: 1 section; 330V a-c operating, 50/60 cycles, 1.0 mf; synthetic oil impregnation type; synthetic oil filled; metal case, hermetically sealed, 1-13/16 in. lg, 1-1/16 in. wide, 2 in. h over-all; solder lug term; bracket mounted; CD part no. KGNJ, MIL type CP 70B1EF105K	Phase shifting, B1; Figure 6-18
C2		SAME AS C1	Phase shifting, B2; Figure 6-18
C3		SAME AS C1	Phase shifting, B3; Figure 6-18
C4		CAPACITOR, FIXED, ELECTROLYTIC: 3 section, 10 uf per section, 200 V dcw; MIL type CE 33C100K, spec MIL-C-62	See C4A, C4B, C4C
C4A		P/O C4	Time constant, overload Channel 1
C4B		P/O C4	Time constant, overload Channel 2
C4C		P/O C4	Time constant, overload Channel 3
C5		CAPACITOR, FIXED, ELECTROLYTIC: 2 section, 40 uf per section; 200 V dcw; MIL type CE 32C400K, spec MIL-C-62	See C5A, C5B
C5A		P/O C5	Ripple reduction, power supply
C5B		P/O C5	Ripple reduction, power supply
CR1		SEMICONDUCTOR DEVICE, DIODE: JAN IN540 spec MIL-E-1/1085A	Rectifier power supply
DC1		COUPLER, DIRECTIONAL 75 OHMS: transmission line type; 2 to 15 mc frequency range; bidirectional type; negligible coupling loss; 5-5/8 in. lg, 2-3/4 in. w, 4-1/2 in. h over-all; main line connection; two connectors M. C. Jones part no. 13891-1 on top, threaded at both ends to mate w/UG-154/U connector: M. C. Jones part no. 280-12, ECI part/dwg 16-00252-000	Power and VSWR sampling, Channel 1; Figure 6-9
DC2		SAME AS DC1	Power and VSWR sampling, Channel 2; Figure 6-9
DC3		SAME AS DC1	Power and VSWR sampling, Channel 3; Figure 6-9

TABLE 7-1. ANTENNA COUPLER GROUP AN/FRA-49 (V),
MAINTENANCE PARTS LIST (cont)

REF. DESIG.	NOTES	NAME AND DESCRIPTION	FUNCTION
DS1		LAMP, INCANDESCENT: 115-125V, 6W; double contact bayonet candelabra base; s-6 bulb, clear, white light emitted; one tungsten filament; 1-1/16 in. max lg over-all; burn any position; Dialco part no. 6S6DC-125 ECI part/dwg 14-00005-002 MIL-STD MS15567-1	Lamp for XDS1
DS2		SAME AS DS1	Lamp for XDS2
DS3		SAME AS DS1	Lamp for XDS3
E1		CLAMP, ELECTRICAL: (connector) MIL-STD part no. MS3057-10A	Clamp for connector P15
E2		SAME AS E1	Clamp for connector P1
E3		CLAMP, ELECTRICAL: (connector) MIL-STD part no. MS3057-6A	Clamp for connector P2
E4		SAME AS E3	Clamp for connector P3
E5		SAME AS E3	Clamp for connector P4
E6		ADAPTER, CONNECTOR: HN series; AN type UG-212C/U, ECI part/dwg 16-00073-001	Adapts P16 to E7; Figure 6-18
E7		ADAPTER, CONNECTOR: 2 connector mating ends; one female and one male contact straight hexagon shape, 2.250 in. lg, 1.625 in. across corners; arc resistant plastic insert; 1-1/4 - 18 internal thread on body, 3/4 - 16 external coupling thread Greomar part no. UG-497 A/U	Adapts E6 to J101 or J201; Figure 6-18
E8		SAME AS E6	Adapts P17 to E9; Figure 6-18
E9		SAME AS E7	Adapts E9 to J101 or J201
E10		SAME AS E6	Adapts P18 to E11; Figure 6-18
E11		SAME AS E7	Adapts E10 to J101 or J201; Figure 6-18
E12		ADAPTER, CONNECTOR: 2 connector mating ends; one female and one male contact; straight hexagon shape, 2.250 in. lg, 1.625 in. across corners; arc resistant plastic insert; 1-1/4 - 18 internal thread in body, 3/4 - 16 external coupling thread; 0.103 in. dia male contact; Greomar part no. UG-497 A/U mod per ECI part/dwg 16-00075-000	Adapts J6 to P6; Figure 6-18
E13		SAME AS E12	Adapts J8 to P8; Figure 6-18
E14		SAME AS E12	Adapts J10 to P10; Figure 6-18
F1		FUSE, CARTRIDGE: 2 amp, 125V; MIL type FO2D2R00B, MS part no. MS90078-26-1, spec MIL-F-15160	Protection, fan B1

TABLE 7-1. ANTENNA COUPLER GROUP AN/FRA-49 (V),
MAINTENANCE PARTS LIST (cont)

REF. DESIG.	NOTES	NAME AND DESCRIPTION	FUNCTION
F1		FUSE, CARTRIDGE: 2 amp, 125V; MIL type FO2D2R00B, MS part no. MS90078-26-1, spec MIL-F-15160	Protection, fan B1
F2		SAME AS F1	Protection, fan B1
F3		SAME AS F1	Protection, fan B2
F4		SAME AS F1	Protection, fan B2
F5		SANE AS F1	Protection, fan B3
F6		SAME AS F1	Protection, fan B3
J1		CONNECTOR, RECEPTACLE, ELECTRICAL: 3 male pin contacts; MS part no. MS3102R18-5P; spec MIL-C-5015, ECI part/dwg 16-00067-087	Power input a-c; Figure 6-2
J2		CONNECTOR, RECEPTACLE, ELECTRICAL: 4 contacts; MS part no. MS3102R145-2P, spec MIL-C-5015, ECI part/dwg 16-00067-025	Remote control, fan B1 Remote interlock, Channel 1
J3		SAME AS J2	Remote control, fan B2 Remote interlock, Channel 2
J4		SAME AS J2	Remote control, fan B1 Remote interlock, Channel 3
J5		P/O DC1 for reference only	Input, DC1; Figure 6-2
J6		P/O DC1 for reference only	Output, DC1 Figure 6-18
J7		P/O DC2 for reference only	Input, DC2; Figure 6-2
J8		P/O DC2 for reference only	Output, DC2; Figure 6-18
J9		P/O DC3 for reference only	Input, DC3; Figure 6-2
J10		P/O DC3 for reference only	Output, DC3; Figure 6-18
J11		FLANGE, ANTENNA CONNECTING: brass, silver pl; 3-1/2 in. dia 1-1/2 in. h over-all; eight 5/16-18 tapped mtg holes on a 2.812 in. dia bolt circle, equally spaced; ECI part/dwg 37-00067-000	Output, radio frequency; Figure 6-2
J12		CONNECTOR, RECEPTACLE, ELECTRICAL: single contact, MS part no. MS35179-1094; spec MIL-C-5105, ECI part/dwg 16-00087-001	Input, overload Channel 1; Figure 6-8

TABLE 7-1. ANTENNA COUPLER GROUP AN/FRA-49 (V),
MAINTENANCE PARTS LIST (cont)

REF. DESIG.	NOTES	NAME AND DESCRIPTION	FUNCTION
J13		SAME AS J12	Input, overload Channel 2
J14		SAME AS J12	Input, overload Channel 3
J15		CONNECTOR, RECEPTACLE, ELECTRICAL: MS part no. MS3102R18-1P, spec MIL-C-5015, ECI part/dwg 16-00067-085	Power and remote interlock, overload chassis; Figure 6-8
K1		RELAY, ARMATURE: contact data, contact arrangement 1A (spst) ac, 115V 15 amp resistive current rating; coil data, 1 winding, AC 390 ohms resistance of winding, 110V operating voltage, 5.5va nom, 60 cycles; 2 terminals for contacts, 2 terminals for coil; continuous duty; hermetically sealed; 1.87 in. lg, 1.43 in. w, 2.75 in. h over-all; three no. 6-32 thd mtg studs on 0.93 by 1.18 in. mtg/c; Aemco type no. I-R83-1-RB, ECI part/dwg 47-00017-000, per spec MIL-R-5757	Remote operating, fan B1
K2		SAME AS K1	Remote operating, fan B2
K3		SAME AS K1	Remote operating fan B3
K4		RELAY, ARMATURE: contact data, contact arrangement 4C (4pdt) AC, 115V, 3 amp resistive current rating; coil data, 1 winding, DC, 5000 ohms resistance, 0.020 amp nom operating current; 2 terminals for coil, 12 terminals for contacts; continuous duty; hermetically sealed; 1.87 in. lg, 1.43 in. w, 3 in. h over-all, three no. 6-32 mtg studs on 0.93 by 1.18 in. mtg/c; Aemco type no. III R83-3-FC, ECI part/dwg 47-00027-001 per spec MIL-R-5757	Overload reset, Channel 1; Figure 6-8
K5		RELAY, METER MOVEMENT: contact data, contact arrangement 1A (spst) 100 ma at 120V AC or DC; meter movement data, sensitivity to 50 ua (0-100 mv) adjustable; reset voltage 120V AC, 48V DC; 6 solder lug terminals; flange size 3-7/64 in. dia, 2-1/2 in. body dia, 1-13/64 in. body depth; metal case; contacts may be adjusted, to close on decreasing or increasing current; three 0.125 in. dia mounting holes on 1.450 in. radius, spaced 120 deg C to C. Weston part no. 1092, ECI part/dwg 47-00028-001	Overload trip Channel 1; Figure 6-8
K6		SAME AS K4	Overload reset, Channel 2
K7		SAME AS K5	Overload trip, Channel 2

TABLE 7-1. ANTENNA COUPLER, GROUP AN/FRA-49 (V),
MAINTENANCE PARTS LIST (cont)

REF. DESIG.	NOTES	NAME AND DESCRIPTION	FUNCTION
K8		SAME AS K4	Overload reset, Channel 3
K9		SAME AS K5	Overload trip, Channel 3
M1		METER, STANDING WAVE RATIO: MIL type MR36W020DCUAR modified with a scale reading "KILOWATTS" calibrated 0 to 5 KW linear w/mark every 100W, and "STANDING WAVE RATIO" scale calibrated in increments of 1.0 to 50.0; 3-1/2 in. dia, 15/16 in. d excluding stud term; three 0.156 in. dia mtg holes on a 1-5/8 in. radius spaced 120 deg C to C; ECI part/dwg 33-00001-000	Measurement, power and VSWR Channel 1; Figure 6-1
M2		SAME AS M1	Measurement, power and VSWR; Channel 2
M3		SAME AS M1	Measurement, power and VSWR; Channel 3
MP1		DIAL, CONTROL: knob type dial; 0 to 100 in increments of 5, ccw; graduated in 100 scale div; direct drive; 3/8 in. dia shaft accommodated; mounted by two set screws; numerals read ccw from radius, retractable lever in knob; approx. 3-5/8 in. dia, 2 in. h over-all; ECI part/dwg 36-00016-002	Actuate tuning shaft, Channel 1; Figure 6-1
MP2		DIAL, CONTROL: knob type dial; 0 to 100 in increments of 5; graduated in 100 scale div; direct drive; 3/8 in. dia shaft accommodated; mounted by two set screws; numerals read ccw from periphery; retractable lever on knob; approx 3-5/8 in. dia, 2 in. h over-all; ECI part/dwg 36-00016-001	Actuate coupling shaft, Channel 1; Figure 6-1
MP3		SAME AS MP1	Actuate tuning shaft, Channel 2
MP4		SAME AS MP2	Actuate coupling shaft, Channel 2
MP5		SAME AS MP1	Actuate tuning shaft, Channel 3
MP6		SAME AS MP2	Actuate coupling shaft, Channel 3
MP7		KNOB: pointer type; plastic, black; MIL STD part no. MS91528-2P2D; ECI part/dwg 34-00007-011	Actuate switch, S4, Channel 1; Figure 6-1

TABLE 7-1. ANTENNA COUPLER GROUP AN/FRA-49 (V),
MAINTENANCE PARTS LIST (cont)

REF. DESIG.	NOTES	NAME AND DESCRIPTION	FUNCTION
MP8		SAME AS MP7	Actuate resistor, R1, Channel 1
MP9		SAME AS MP7	Actuate switch S5, Channel 2
MP10		SAME AS MP7	Actuate resistor, R3, Channel 2
MP11		SAME AS MP7	Actuate switch, S6, Channel 3
MP12		SAME AS MP7	Actuate resistor, R5, Channel 3
MP13		FILTER, AIR CONDITIONING: aluminum frame; aluminum crimped screen cloth filter media; 11 in. lg, 9 in. w, 3/4 in. thk over-all; Air Maze part no. 122131, ECI part/dwg 59-00002-000, per spec MIL-F-16552	Filter for fan, B1 Figure 6-2
MP14		SAME AS MP13	Filter for fan, B2
MP15		SAME AS MP13	Filter for fan, B3
MP16		HOSE, AIR DUCT; helical wire frame, fabric covered; 16 in. free lg, 8-7/8 in. dia; compresses to 6 in. lg, ECI part/dwg 43-00010-000	Air duct, Channel 1; Figure 6-10
MP17		SAME AS MP16	Air duct, Channel 2
MP18		SAME AS MP16	Air duct, Channel 3
MP19		CLAMP, HOSE: stainless steel; 9 in. nom dia, 3/8 in. w over-all integral screw type fastener; 0.020 in. thk wall; National Utilities part no. E70-900, ECI part/dwg 30-00019-000	For air ducts, MP16, MP17, MP18; Figure 5-2
MP20		JACK, LEVELING-SUPPORT: steel; 2-1/2 in. dia, 1-3/4 in. h over-all; hex head on leveling screw; four 1/4 20 thk mounting holes on a 1-1/32 in. radius spaced 90 deg C to C; ECI part/dwg 03-00013-000	For leveling antenna coupler group; Figure 6-8
MP21		INSULATOR-SUPPORT, RETAINER SUB-ASSEMBLIES: silicone glass laminate; 11-1/8 in. sq, 3/8 in. thk over-all; cut-out in each corner on a 5-1/4 in. radius; two 0.206 in. dia mtg holes on each side spaced 1.000 in. C to C; ECI part/dwg 37-00046-000	Capacitor support; Figure 6-13

TABLE 7-1. ANTENNA COUPLER GROUP AN/FRA-49 (V),
MAINTENANCE PARTS LIST (cont)

REF. DESIG.	NOTES	NAME AND DESCRIPTION	FUNCTION
MP22		INSULATOR, SCREW: ECI part/dwg 23-00907-000	Secure insulator MP23; Figure 6-14
MP23		INSULATOR, WEDGE: ECI part/dwg 57-00002-000	Adjusts coilform posi- tion, MP24, MP25, MP26, MP27; Figure 6-14
MP24		FORM, COIL: (coil support member) ECI part/dwg 57-00003-001	Coil support
MP25		FORM, COIL: (coil support member) ECI part/dwg 57-00003-002	Coil support; Figure 6-15
MP26		FORM, COIL: (coil support member) ECI part/dwg 57-00003-003	Coil support
MP27		FORM, COIL: (coil support member) ECI part/dwg 57-00003-004	Coil support
MP28		SUPPORT, COIL FORM: ECI part/dwg 57-00007-000	Support, Coil form, MP24 thru MP27
MP29		INSULATOR, COIL, TUNER: ECI part/dwg 54-00011-000	Insulator, loop, L2, L4 or L6
MP30		SPRING, COMPONENT SEATING: ECI part/dwg 42-00003-000	Seating, capacitors, C7 thru C18; Figure 6-11
MP31		HALF COUPLING, SHAFT: ECI part/dwg 30-00006-000	P/O coupling for capacitors C7 thru C18; Figure 6-11
MP32		COUPLING, SHAFT: ECI part/dwg 30-00007-000	P/O coupling for capacitors C7 thru C18; Figure 6-11
MP33		STRAP, RETAINING, COMPONENT: ECI part/dwg 18-00022-000	Retain capacitors, C7 thru C18; Figure 6-11
P1		CONNECTOR, PLUG, ELECTRICAL: angle type; MIL STD part no. MS3108B-18-5S, spec MIL-C-501S	Mates w/J1
P2		CONNECTOR, PLUG, ELECTRICAL: 4 contacts; MS part no. MS3106A145-2S, spec MIL-C-5015, ECI part/dwg 16-00079-024	Mates w/J2
P3		SAME AS P2	Mates w/J3

TABLE 7-1. ANTENNA COUPLER GROUP AN/FRA-49 (V),
MAINTENANCE PARTS LIST (cont)

REF. DESIG.	NOTES	NAME AND DESCRIPTION	FUNCTION
P4		SAME AS P2	Mates w/J4
P5		CONNECTOR, PLUG, ELECTRICAL: LC series, MIL type UG-154/U, ECI part/dwg 16-00177-001	Mates w/J5
P6		CONNECTOR, PLUG, ELECTRICAL: HN series; MIL type UG-59D/U, ECI part/dwg 16-00062-002	RF Tuner Input, P/O W1, Channel 1
P7		SAME AS P5	Mates w/J7
P8		SAME AS P6	RF Tuner input, P/O W2, Channel 2
P9		SAME AS P5	Mates w/J9
P10		SAME AS P6	RF Tuner input, P/O W3, Channel 3
P11		CONNECTOR, RADIO FREQUENCY: aluminum alloy, 3-9/16 in. dia, 2-1/2 in. d over-all; four 5/16-18 thd hex head mtg bolts on a 2-7/16 in. dia bolt circle, spaced 90 deg C to C; 75-ohm impedance; Comm Prod part no. 5-520, ECI part/dwg 16-00268-000	Mates w/J12
P12		CONNECTOR, PLUG, ELECTRICAL: single contact, MS part no. MS35168-88D, spec MIL-C-5015	Mates w/J12
P13		SAME AS P12	Mates w/J13
P14		SAME AS P12	Mates w/J14
P15		CONNECTOR, PLUG, ELECTRICAL: MIL STD part no. MS3106R18-1S, spec MIL-C-5015, ECI part/dwg 16-00119-097	Mates w/J15
P16		SAME AS P6	Antenna Coupler input, P/O W1, Channel 1
P17		SAME AS P6	Antenna Coupler input, P/O W2, Channel 2

TABLE 7-1. ANTENNA COUPLER GROUP AN/FRA-49 (V),
MAINTENANCE PARTS LIST (cont)

REF. DESIG.	NOTES	NAME AND DESCRIPTION	FUNCTION
P18		SAME AS P6	Antenna Coupler input, P/O W3, Channel 3
R1		RESISTOR, VARIABLE: Composition; 25,000 ohms \pm 5 per cent, 2W; MIL type RV4NAYS253A, spec MIL-R-94/5	VSWR calibrate, M1, Channel 1
R2		RESISTOR, VARIABLE: Composition; 25,000 ohms \pm 5 per cent, 2W; MIL type RV4LAYS253A, spec MIL-R-94/5	Power calibrate, M1, Channel 1
R3		SAME AS R1	VSWR calibrate, M2, Channel 2
R4		SAME AS R2	Power calibrate, M2, Channel 2
R5		SAME AS R1	VSWR calibrate, M3, Channel 3
R6		SAME AS R2	Power calibrate, M3, Channel 3
R7		RESISTOR, FIXED, COMPOSITION: 100 ohms \pm 10 percent, 1/2 W; MIL type RC20-GF101K, MIL STD MS35043-7, spec MIL-R-11	Current limiting C19
R8		RESISTOR, FIXED, COMPOSITION: 1,000 ohms \pm 10 percent, 2W; MIL type RC42GF102K, MIL STD MS35045-13, spec MIL-R-11	Ripple reduction, power supply
R9		RESISTOR, FIXED, COMPOSITION: 15,000 ohms \pm 10 percent, 2W, MIL STD MS35045-20, spec MIL-R-11	Bleeder, power supply
R10		RESISTOR, FIXED, COMPOSITION: 3,900 ohms \pm 5 percent, 1/2 W; MIL STD MS35043-101, MIL type RC20GF392J	Power Calibrate, Channel 1
R11		SAME AS R10	Power Calibrate, Channel 2
R12		SAME AS R10	Power Calibrate, Channel 3
S1		SWITCH, TOGGLE: dpdt; MIL STD part no. MS35059-22, spec MIL-S-3950; ECI part/dwg 07-00005-002	Actuate fan, B1
S2		SAME AS S1	Actuate fan B2

TABLE 7-1. ANTENNA COUPLER GROUP AN/FRA-49 (V),
MAINTENANCE PARTS LIST (cont)

REF. DESIG.	NOTES	NAME AND DESCRIPTION	FUNCTION
S3		SAME AS S1	Actuate fan B3
S4		SWITCH, ROTARY: 1 section ; 4 position max number of switching positions, 30 deg positioning increment; 2 moving contacts, 10 fixed contacts; silver alloy contacts; ceramic insulation; 5/8 in. lg, 1.937 in. dia over-all; bushing mtd, 3/8-32 thd, 3/8 in. lg mtg bushing; round type shaft, 7/8 in. lg, 1/4 in. dia; solder lug term; Oak type DHC per ECI part/dwg 07-00009-001, per spec MIL-S-6807	Selector for VSWR, power, M1, Channel 1
S5		SAME AS S4	Selector for VSWR, power, M2, Channel 2
S6		SAME AS S4	Selector, VSWR, power, M3, Channel 3
S7		SWITCH, SENSITIVE: spdt: MIL STD part no. MS16106-1	Interlock, left side panel; Figure 6-9
S8		SAME AS S7	Interlock, right side panel
TB1		TERMINAL BOARD: phenolic board, MIL type 8TB6, spec MIL-M-14, ECI part/dwg 5200283-006	Blower, connection, B1
TB2		SAME AS TB1	Blower connection, B2
TB3		SAME AS TB1	Blower connection, B3
TB4		TERMINAL BOARD: phenolic board, MIL type 8TB2, spec MIL-M-14, 52-00283-002	Interlock connection, S7, S8; Figure 6-9
TB5		TERMINAL BOARD: phenolic board, spec MIL-P-15047, type MPG; 10 solder stud type term; 2-5/8 in. lg, 2 in. w, 1/8 in. thk; four 4-40 thd tapped mtg inserts on 2-1/4 by 1-1/2 in. mtg centers; Cambridge Therm part no X-1401N-B-1-1/7, ECI part/ dwg 52-00160-056	Mount for R7, R8, R9 and CR1
W1		CABLE ASSEMBLY, RADIO FREQUENCY: coaxial arrangement, 75 ohms nom impedance, AN type RG-144/U cable; 51 in. lg over-all; terminated at each end w/AN type UG-59B/U connector; ECI part/dwg 31-00027-000	R-f input, Channel 1, Figure 6-10
W2		SAME AS W1	R-f input, Channel 2

TABLE 7-1. ANTENNA COUPLER GROUP AN/FRA-49 (V),
MAINTENANCE PARTS LIST (cont)

REF. DESIG.	NOTES	NAME AND DESCRIPTION	FUNCTION
W3		SAME AS W1	R-f input, Channel 3
W4		WIRING HARNESS, BRANCHED: ECI part/dwg 12-00061-000	Antenna coupler wiring system
XDS1		LIGHT, INDICATOR: supplied w/lens, 3/4 in. dia, red, clear, smooth face, thd mounted lens holder, nickel plated; accommodates one incan- descent lamp, bayonet candelabra base; shell type; 3-1/16 in. lg, 1-1/8 in. dia over-all; bush- ing mounted, 1 in. dia mtg hole required; 1/16 in. max panel thk accommodated; lamp replaceable from front of panel; 2 solder lug type term, located on rear of lampholder; Dialco part no. 78202-11, ECI part/dwg 14-00004-001	Indicator, fan, Channel 1
XDS2		SAME AS DS1	Indicator, fan, Channel 2
XDS3		SAME AS DS1	Indicator, fan, Channel 3
XF1		FUSEHOLDER: extractor post type; w/integral indicator, neon lamp type; MIL type 9000-56202- F-74229, ECI part/dwg 17-00001-001	Mount for fuse F1; Figure 6-8
XF2		SAME AS XF1	Mount for fuse, F2
XF3		SAME AS XF1	Mount for fuse, F3
XF4		SAME AS XF1	Mount for fuse, F4
XF5		SAME AS XF1	Mount for fuse, F5
XF6		SAME AS XF1	Mount for fuse, F6
XF1, XF2, XF3 (Spare)		SAME AS XF1	Holder for spare fuse, F1, F2 or F3; Figure 6-8
XF4, XF5, XF6 (Spare)		SAME AS XF1	Holder for spare fuse, F4, F5 or F6

TABLE 7-1. ANTENNA COUPLER GROUP AN/FRA-49 (V),
MAINTENANCE PARTS LIST (cont)

REF. DESIG.	NOTES	NAME AND DESCRIPTION	FUNCTION
XFL1		For schematic reference only	Position for CU-998/FRA-49(V) or CU-999/FRA-49(V)
XFL2		For schematic reference only	Position for CU-998/FRA-49(V) or CU-999/FRA-49(V)
XFL3		For schematic reference only	Position for CU-998/FRA-49(V) or CU-999/FRA-49(V)
Series 101 thru 199		COUPLER ANTENNA CU-998/FRA-49 (V)	
C101		CAPACITOR, VARIABLE, VACUUM DI- ELECTRIC: 1 section, 650 uuf max, 30 uuf min, straightline capacity tuning characteristic; 55,000V max r-f peak voltage, 125 amp max rms; knob type adjustment; ccw rotation from min to max capacity, 57 complete turns; 17 in. lg, 8-1/8 in. dia over-all; glass enclosed; 2 ferrule type terminals, located at ends; term mounted; Jennings part no.VMMHC-650 mod per ECI part/dwg 11-00069-001	Tuning, R-f, 2-6 mc; Figure 6-13
C104		SAME AS C102	Impedance divider tap, R-f, 2-6 mc
C105		SAME AS C102	Impedance divider tap, R-f, 2-6 mc
J101		CONNECTOR, RECEPTACLE, ELECTRICAL: LC type; MIL type UG-352/U w/ elongated contact mod per ECI dwg 16-00071-000	Input, R-f tuner, 2-6 mc
L-101		COIL, RADIO FREQUENCY: 13 turns, single layer wound type; conductor data, copper tubing 3/8 in. od, 5/16 in. id; approx. 13-5/8 in. dia, 19-1/4 in. lg over-all, incl. integral coil form and mounting facilities; ECI part/dwg 03-00018-000	Tuning, R-f, 2-6 mc; Figure 6-15
L-102		LOOP, PICK-UP, TUNER: brass, silver plated, 7-7/8 in. dia, 1/2 in. thk over-all; 2 electrical leads extending from one edge, approx. 2-1/2 in. lg; ECI part/dwg 37-00113-000	Output Link, 2-6 mc; Figure 6-14
Series 201 thru 299		COUPLER, ANTENNA CU-999/FRA-49(V)	

TABLE 7-1. ANTENNA COUPLER GROUP AN/FRA-49 (V),
MAINTENANCE PARTS LIST (cont)

REF. DESIG.	NOTES	NAME AND DESCRIPTION	FUNCTION
C201		CAPACITOR, VARIABLE, VACUUM DI-ELECTRIC: 1 section; 450 uuf max, 25 uuf min, straightline capacity tuning characteristic; 55,000V max r-f peak voltage, 125 amp max rms; knob type adjustment; ccw rotation from min to max capacity, 57 complete turns, 16 in. lg, 8-1/8 in. dia over-all; glass enclosed; 2 ferrule type terminals, located at ends; term mounted; Jennings part no. VMMHC450 mod per ECI part/dwg 11-00069-002	Tuning, R-f, 5 to 15 mc; Figure 6-13
C202		CAPACITOR, VARIABLE, VACUUM DI-ELECTRIC: 1 section; 2000 uuf max 100 uuf min, straightline capacity tuning characteristic; 2,000V max r-f peak voltage; 40 amp max rms; knob type adjustment; cw rotation from min to max capacity, 19 complete turns lg, 3-1/16 in. dia over-all; glass enclosed; 2 ferrule type terminals, located at ends; term mounted; Jennings part no. UCSL2000, mod per ECI part/dwg 11-00070-002	Impedance Divider Tap, R-f, 5 to 15 mc; Figure 6-13
C203		SAME AS C202	Impedance Divider Tap, R-f, 5 to 15 mc
C204		SAME AS C202	Impedance Divider Tap, R-f, 5 to 15 mc
J201		SAME AS J101	Input, R-f tuner, 5 to 15 mc
L-201		COIL RADIO FREQUENCY: 5-1/2 turns, single layer wound type; conductor data, copper tubing, 0.5 in. od, 0.402 in. id; approx. 13-5/8 in. dia, 16 in. lg over-all; incl. integral coil form and mounting facilities; ECI part/dwg 03-00639-000	Tuning, R-f, 5 to 15 mc; Figure 6-15
L202		COIL RADIO FREQUENCY: 1 turn, single layer wound type, conductor data, 1/2 in. od, 7/16 id; approx 1/2 in. lg, 7-1/8 in. dia over-all; 2 wire lead term; ECI part/dwg 09-00156-000	Output Link, 5 to 15 mc; Figure 6-14

TABLE 7-2. LIST OF MANUFACTURERS

ABBREVIATION	NAME	ADDRESS
AEMCO	AEMCO INC.	62 State Street Mankato, Minn.
AMPHENOL	AMPHENOL CONNECTOR DIV. AMPHENOL-BORG ELECTRONICS	1830 So. 54th Ave. Chicago, Ill.
CD	CORNELL-DUBILIER ELEC. CORP.	333 Hamilton Blvd. S. Plainfield, N. J.
CAMBRIDGE THERM	CAMBRIDGE THERMIONIC CORP.	Cambridge, Mass.
COMM. PROD.	COMMUNICATION PROD. CORP.	Marlboro, N. J.

TABLE 7-2. LIST OF MANUFACTURERS (cont)

ABBREVIATION	NAME	ADDRESS
DIALCO	DIALIGHT CORPORATION	60 Stewart Ave. Brooklyn, N. Y.
F. I. C.	FUSE INDICATOR CORP.	512 Colorado Bldg. Washington, D. C.
GREMAR	GREMAR MFG. CO., INC.	Wakefield, Mass.
JENNINGS	JENNINGS RADIO MFG. CORP.	P. O. Box 1278, San Jose, Calif.
KULKA	KULKA ELECTRIC CORP.	Mount Vernon, N. Y.
M.C.JONES	M. C. JONES ELECTRONICS CO.	185 N. Main St. Bristol, Conn.
OAK	OAK MANUFACTURING CO.	1260 N. Clybourne Chicago, Ill.
ROTRON	ROTRON MFG. CO.	Schoonmaker Lane Woodstock, N. Y.
WESTON	WESTON INSTRUMENTS DIV. DAYSTROM INC.	Newark, N. J.

INDEX

SUBJECT	PARA- GRAPH (Figure) *Table
A	
Adjustments	2-4
Installation	2-4d
Mechanical	2-4e
Operators maintenance	3-1, 6-2
B	
Block diagrams. (See Diagrams.)	
C	
Cable assembly	2-3
Calibration curves	6-2b
Capabilities	1-1
Changes	1-3
Characteristics of equipment	1-4
Charts, check	5-1
D	
Diagrams:	
Block, overall, functional	(4-1)
Schematic	6-8 (6-18)
Simplified schematic	(4-2, 4-3)
Wiring	6-8 (6-17)
E	
Electron tube complement	1-5d, *1-3
Electrical checks:	
Installation	2-4b
Repair	*6-1
Electronic Failure Report	6-1
Emergency maintenance	6-3
Equipment:	
Changes	1-3
Characteristics of	1-4
Illustration	(1-1)
Lists	1-5
Location of	2-2
Photograph or line drawing of	(1-1)
Supplied	*1-1
Unpacking and handling	2-1
F	
Failure report	6-1
Field changes	1-3
Functional description	4-1
H	
Handling	2-1
I	
Inspection, installation	2-4
Installation:	
Adjustments	2-4d
Inspection	2-4
Layout	(2-1)
Requirements	2-2
Interference, R. F.	2-5

SUBJECT	PARA- GRAPH (Figure) *Table
K	
Key part	7-1
L	
Layout, installation	(2-1)
Location of:	
Equipment	2-2
Site selection	2-2
M	
Maintenance:	
Check charts	5-1
Emergency	6-3
Manufacturers, List of	7-3
N	
Noise, radio interference	2-5
O	
Operating	3-1
Procedures (summary of)	3-1
Operation	3-1
Emergency	3-2, 6-3
Functional overall description	4-1
Functional sections description	4-2
Principles of	4-1
Theory of	4-1
Operator's section	3-1
Precautions	3-2
Outline drawings, installation	(2-1)
P	
Part:	
Key	7-1
Parts	
Location	5-2
Replacement	6-6
Standards for	*7-1
Supplied, list of	*7-1
Parts List:	
Introduction	7-1
Maintenance	*7-1
Power requirements	2-2
Precautions, operators	3-2
Principles of operation	4-1
R	
Reassembly of equipment	6-6
Reference data	1-4
Relays	6-5a, 6-6b
Replacement parts, standards for	*7-1
Reports, failure	6-1
Reshipment	2-6
S	
Schematic diagram:	
Overall	(6-18)
Simplified	(4-2, 4-3)
Shipping data	*1-2
Site, location of	2-2
Stock number	7-4

SUBJECT	PARA- GRAPH (Figure) *Table
T	
Test equipment	*5-1, 6-6a
Theory of Operation	4-1
Trouble-shooting:	
Functional section	5-4
Overall	5-3
Troubles, Typical	*5-7, 5-5
Tube, complement	*1-3
Tuning	2-4d, 6-2

SUBJECT	PARA- GRAPH (Figure) *Table
U	
Unpacking	2-1
V	
Voltmeter	*5-1
W	
Wiring diagrams	(6-17)

