

R-390 and R-390A Receivers

2000

Substitutes for the 3TF7 Ballast Tube A variety of substitution/modifications to replace the ballast tube in both the R-390 and R-390A have been put forth in HSN. Spares for this tube are available although at relatively high prices through suppliers such as Fair Radio and Antique Electronic Supply. Ballast tubes function as automatic rheostats keeping a constant current to the BFO/PTO tube filaments, even if there is a line voltage surge or drop - resistors don't do it. The best alternative is to get additional 3TF7's, but you may want to try some of these modifications.

Dick Truax offers the following three substitutions which work for both receivers:

1. A quick, but temporary, fix if you don't have a spare is to remove the 3TF7 and connect a 42 ohm, 5 watt resistor between pins 2 and 7 of the 3TF7 socket:
2. Replace the regulated tubes V5508 (V505 in the R-390A) and V701 (BFO and PTO tubes) with 12BA6's, remove the 3TF7 and plug a short wire jumper between pins 2 and 7 of the 3TF7 socket;
3. Build a triac regulator, such as the one at right, which can be plugged into pins 2 and 7 of the 3TF7 socket. The diodes are 100 V, 0.5 A, and the zener is 14-15 V. Ground the regulator circuit to one of the tube mounting screws. Adjust the pot for 12.6 VDC at 3TF7 pin 7.
[Issue 2, pg 5]

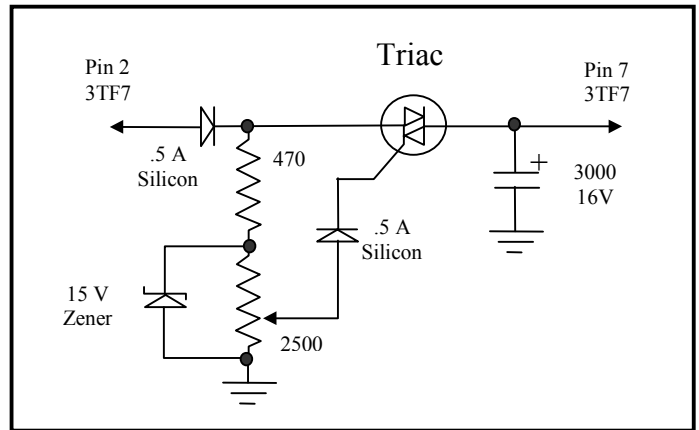

A possible substitute for the 3TF7 is to modify a 12BH7A. Gerald Murphy writes "When the RT-510 tube (the 3TF7) in my R-390A failed, I devised a simple interim substitute while trying to track down a new tube. I used the 12.6 volt heater section of a 12BH7 9-pin miniature tube connected in series with the heaters of the BFO and PTO tubes. The appropriate pins of the tube were connected together as shown in the accompanying diagram so the tube can be plugged right into the regulator socket. The shunting wires were soldered into place after scraping each pin to get good contact. I used a heat sink in the form of a hemostat to protect the tube. This setup works well and could be used permanently. I could detect no adverse effect on stability after warm-up. There may be a bit of regulating action, in fact, since variations in current would presumably cause some temperature-dependent effects on resistance and current in the three heaters. I think this is a better way to go than to replace the two oscillators with 12.6 volt heater tubes; that route may result in a need to do some regulating of the PTO to get accurate calibration and linearity." [Issue 10, pgs 1 & 2]

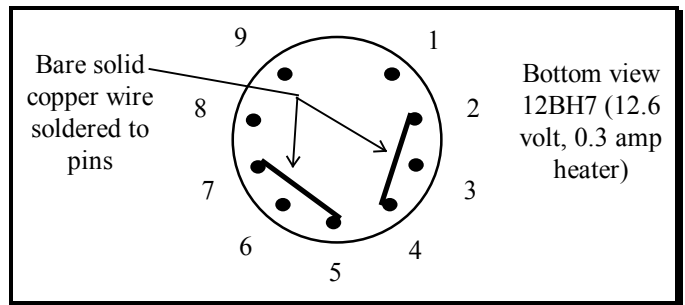

This setup works well and could be used permanently. I could detect no adverse effect on stability after warm-up. There may be a bit of regulating action, in fact, since variations in current would presumably cause some temperature-dependent effects on resistance and current in the three heaters. I think this is a better way to go than to replace the two oscillators with 12.6 volt heater tubes; that route may result in a need to do some regulating of the PTO to get accurate calibration and linearity." [Issue 10, pgs 1 & 2]

Another substitution using zener diodes comes from Irving Megeff. In the accompanying figure, R1 is a 40 ohm, 5 watt resistor and Z1 and Z2 are 13 volt, 5 watt zener diodes, 1N5350 or equivalent. The unused

R-390 and R-390A Receivers

2000

pin lugs on the RT510 (aka 3TF7) socket can be used to mount the components. Dallas Lankford adds: "This is certainly one of the simplest substitutes for the 3TF7 that we have seen in HSN. If you have been living without a 3TF7 since your last one died, using only a dropping resistor, you may want to give Irving's circuit a try. To make an almost plug-in version, use a 9-pin tube test socket with lugs around the top to mount the components. For a ground, solder a short length of stranded, insulated wire to an internal tooth ground lug and mount the lug to a nearby screw on the top of the IF subchassis, such as one of the screws which secures the BFO-PTO mounting bracket." [Issue 17, pgs 5 & 6]

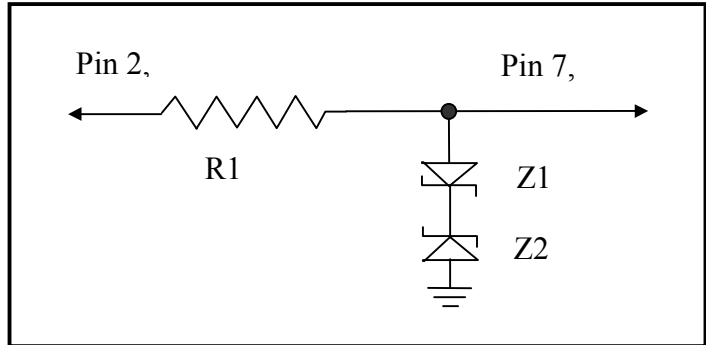

Yet one more technique – The basic maneuver is to tap 12.6 VAC from the secondary of the power supply transformer and supply it to the series connected heaters of the BFO and PTO tubes. I decided to do this after reading in the Collins Engineering Reports that Collins engineers did not feel the 3TF7 was needed, but included it to satisfy the Signal Corp specs. The procedure is as follows: (1) Remove the power supply subchassis. Solder an insulated, stranded #22 wire from the power transformer secondary lug #9, which is a 12.6 VAC tap on the 25.2 VAC supply, run it to lug J-811-9, the unused lug, on the power supply output jack, slip an insulating sleeve over the wire, solder the connection, and slide the sleeve over the solder joint. (2) Open plug P-111 by removing the clamp and two Phillips head screws, and push back the metal shield to expose the contacts. Locate lug P-111-1, which should have two brown and white wires connected to it. In my R-390A the smaller diameter wire of the two runs to lug P-112-8, and is the line to pin 2 of the RT-510 socket. Cut this wire close to lug P-111-1, slide an insulating sleeve over it, solder it to P-111-9, and slide the insulating sleeve over the solder joint. I had to splice a short piece of wire to reach P-111-1, and covered the whole thing with a tough plastic sleeve. (3) Finally, connect pins 2 and 7 of the RT-510 socket. [Gerald Murphy, Issue 18, pg 4]

Here is another solution to the expensive and difficult to find R-390A ballast tube. It is taken from a MARS article by Don, AFF4MS in the March-April 1984 issue of Department Of The Air Force Communicator, Air Force Communications Command, HQ AFCC/TPMOG, Scott AFB, IL 62225. The schematic below tells most of the story. The article suggests removing the 3TF7 tube socket and making

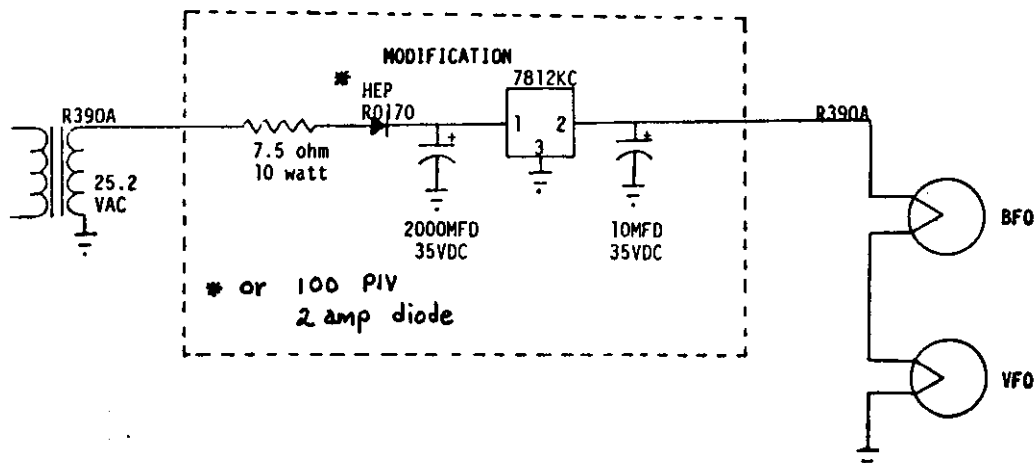

R-390 and R-390A Receivers

2000

the circuit a permanent addition to your IF subchassis. I am opposed to that approach, and recommend that you get a 9-pin miniature tube test socket with solder lugs and make the circuit plug-in. Well, you can't quite make it plug-in because none of the 3TF7 pins are grounded. You will need a short length of insulated, stranded wire with a lug on one end to attach to a nearby screw. The 7812KC regulator package should run warm to the touch, but not hot. I don't recall who sent this article to me.

An identical circuit, apparently taken from the article above, was published in the Nov. 1985 issue of *AM Press Exchange* by B. Harp, N4GSB. I should mention that this ballast tube replacement is not as simple as Irving Megeff's dual 13 volt 5 watt zener diodes and 40 ohm resistor circuit which appeared in HSN 17 (Fall 1987). Also, as George Ross pointed out in HSN 23 (Fall 1989), after he did the dual zener mod, the 5 watt (40 ohm) resistor recommended by Megeff ran hot. It was replaced by three 15 ohm 10 watt resistors in series. This suggests that a higher wattage dropping resistor may be desirable in the mod below. If the zener diode mod is simpler, then why consider this mod? As far as I know, no one has compared these mods with each other or with a 3TF7 ballast tube to determine which one results in a more stable PTO frequency. Obviously, a performance freak would want to try all three and choose the best. [Lankford, Issue #24/25, pgs 5,6]

Increased Audio Gain

Place a jumper across pins 6 and 8 on the terminal strip on the back of the R-390A. [Herkimer, Issue 1, pg 2]

Reattaching Tuning Cores

Ever have a tuning core fall off its rod? Remove the adjustment screw from the bracket by taking out the two Philips head screws, remove the bracket, and unscrew the adjusting screw all the way out. Take a small amount of epoxy and put it on the end of the adjustment screw and jam it into the hole in the ferrite rod. Wait 15 minutes and remove both the screw and the core. Carefully re-screw the adjustment screw with the ferrite rod attached back into the mounting bracket and align the adjustment screw bracket with the tuning bracket, insert the Philips head screws and proceed with normal peaking procedures. [Heinen, Issue 2, pg 2]

Tube Shields

The 'stock' R-390A comes with a full complement of tube shields. For improved cooling and extended tube life (as per Army manual TM11-5820-358-20), all tube shields, except those on V201, V206, V505 and V701 can be removed. There does not appear to be any new leakage paths around the mechanical filters with any other tube shields removed. [Lankford, Issue 5, pg 3]

R-390A SSB Mod – The Cornelius Modification

A major reason for poor SSB performance is inadequate AGC voltage which fails to keep SSB signal levels at the diode detector below the BFO signal level, thus causing severe distortion on strong signals. This mod increases AGC voltage and shortens attack time, which frequently improves SSB and RTTY performance. Referencing the Before and After diagrams, perform the following steps: (1) remove the IF subchassis, (2) remove R545 (100 K), (3) install a diode (1N914/1N34/1N60/1N4148) in place of R546 (180 K) with the cathode (band end) facing the tube socket, (4) replace R547 (220 K) with a 10 K ½ watt, (5) examine R504 – if it is not 560 ohms, replace it with that value (this was a production change in some models), (6) replace the IF subchassis, (7) realign the BANDWIDTH and BFO PITCH knobs. Please note that this mod does not improve SSB on some early R-

R-390 and R-390A Receivers

2000

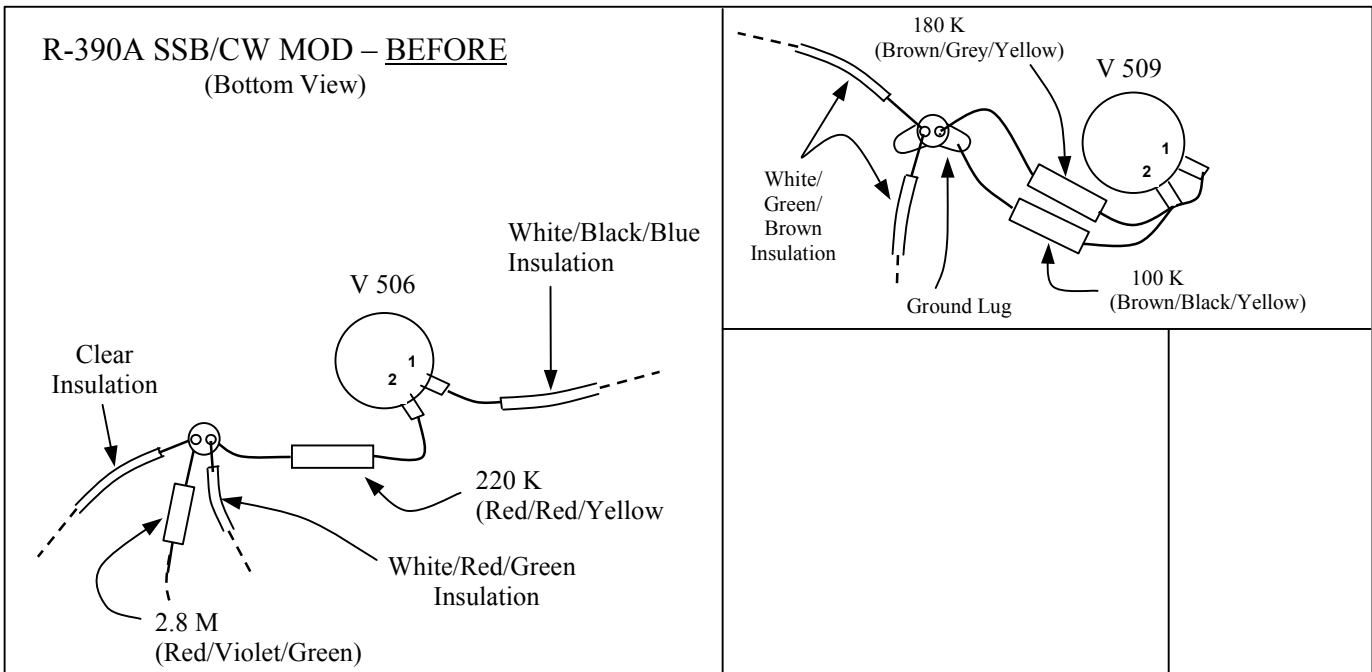
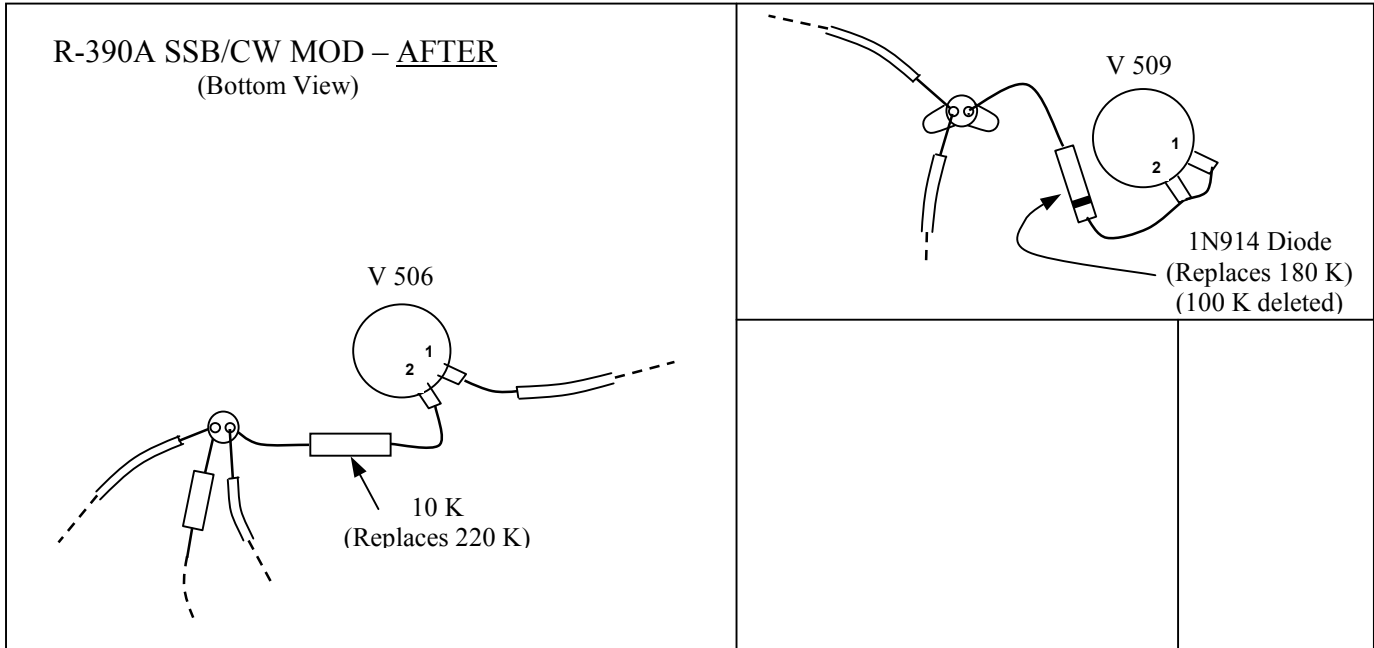

390A's. Before you try the mod, remove the IF transformer shields and examine the Q-spoiling resistors inside the shields which are in parallel with the inputs and outputs of the IF transformer coils. If the resistors in the two T501/T502 cans are 39K, and in T503 is 68K, the mod should work, while if the resistors are 47K and 82K respectively, the mod probably will not work. Replacing the 47K and 82K resistors with 39K and 68K respectively did not help in my experience, suggesting that early IF transformer coils may have different turns ratios and/or couplings from later models. [Cornelius/Lankford, Issue 1, pg 2 and Selected Reprints from Numbers 1 – 4, pgs 2,3]

R-390 and R-390A Receivers

2000

R-390A Power Supply Modifications *With the past difficulties in finding the 26Z5W full wave rectifier tubes, there have been articles on converting the rectifiers to solid state as well as at least one use of alternative tubes with a wiring change. The tubes are still available at reasonable prices from Antique Electronics Supply, Daily Electronics Corp. and probably several others thus making the solid state conversion quite unnecessary.*

If the conversion to diodes has been done in your R-390A, it deserves your attention. My most recent manual (1979) describes the solid state conversion without a dropping resistor. However, the diodes increase the B+ voltage by 25 to 30 VDC over that produced with the 26Z5W rectifier tubes. If a dropping resistor is not used to bring the B+ down to 240 VDC, the 6AK6 line and local AF output tubes will operate beyond their maximum ratings, causing excessive tube failures and possible damages to associated components. So R-390A users should check out their power supply. Originally this contribution was much longer, with details about how to convert the power supply to solid state, replacing the 26Z5W tubes with 1000 PIV, 1 A or better diodes. This conversion was thought to be needed because 26Z5W tubes were thought to be generally unavailable. I have subsequently unmodified my R-390A's back to their original condition, and use 26Z5W tubes. However, I have retained a dropping resistor (currently 75 ohms) because measurement showing that B+ was about 265 VDC with the 26Z5W's alone. Measurement with the diode mod and no dropping resistor was a whopping 290 VDC. Voltages in an R-390A also depend on the strength of a received signal, and on the FUNCTION switch setting, STAND BY/AGC/MGC/CAL. Manual B+ and tube pin voltages seem to be for AGC (FUNCTION) with no antenna attached and no signal received. [Lankford, Selected Reprints From Numbers 1 - 4, pgs 3,4]

If you are still determined to do the conversion, Dallas did provide a step-by-step process. You might also want to get a copy of one of the original solid state conversion articles. Write to IRCA Bookstore, 9705 Mary NW, Seattle WA 98117 and ask for reprint M23-3-2 - Ed.

There are several potential ways to do the mod, from as simple as soldering the diodes across pins 1 (or 6) and 3 (or 8) of the 26Z5W sockets and removing the tubes, to as complicated as removing the tubes, sockets and their associated circuitry before adding the diodes. If the dropping resistor is to be mounted on the power supply subchassis, the latter approach should probably be used to facilitate mounting the resistor for good ventilation (the dropping resistor gets quite warm). In my opinion the preferable place to mount the dropping resistor is on the AF subchassis. B+ voltage enters the AF subchassis through pin 5 of J619 and is then routed to L601 by an insulated wire (which is part of the wiring harness). The AF chassis has a plate which covers holes in the chassis, and so is a convenient place to mount a dropping resistor. One hole is drilled for mounting R on top of the AF chassis, and one hole is drilled to bring two wires from the underside of the chassis. Cut the wire which provides B+ to L601 at pin 5 of J619, pull the wire out of the wiring harness until there is enough slack to reach one of the solder lugs on R, and solder to that lug. Remove any solder and wire or other residue from pin 5 of J619, and then solder a length of insulated wire to pin 5 which is long enough to reach the other lug on R. Be sure to save and re-use the insulating sleeve which originally insulated the pin 5 solder joint and lug. If I remember correctly, wire size is #22 stranded. Because many R-390A users will probably convert their power supplies to solid state, it would be a good idea to settle upon a standard approach. Mounting R on the AF subchassis is apparently commonly used by hams, so I have used that approach. [Lankford, Issue #2, pg 5]

Although there are no direct substitutions for the 26Z5W, a little re-wiring does offer a possibility.

R-390 and R-390A Receivers

2000

The 6V4/EZ80 can be used as an inexpensive substitute for the scarce 26Z5W rectifiers in the R-390A when a simple wiring change is made to the rectifier sockets. Usually the power supply subchassis wiring connects pins 4 of the rectifier socket with a wire, and then from one pin 4 another wire runs to lug 8 of T801. Also, pins 5 are connected with a wire, and one pin 5 is connected to a nearby ground lug.

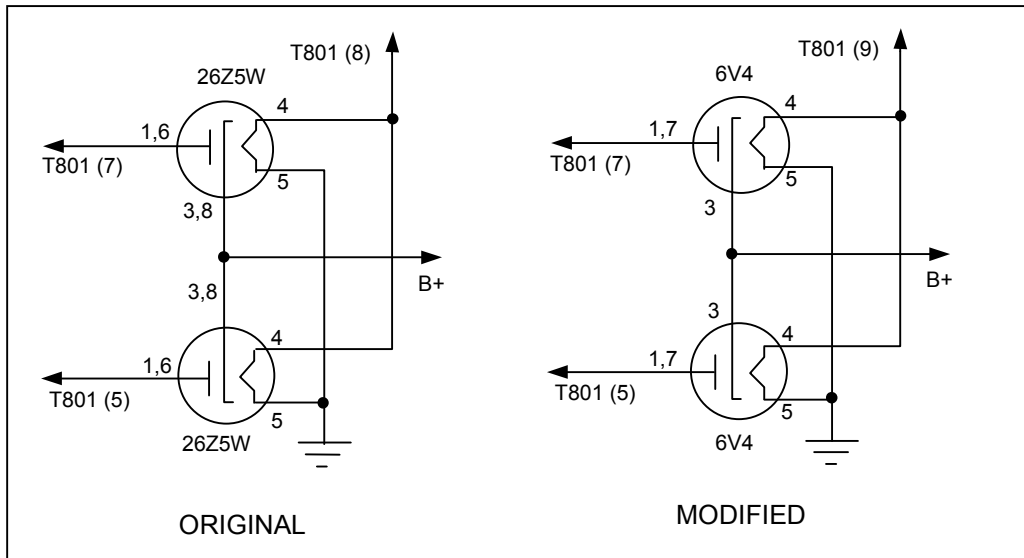

To rewire the 26Z5W sockets for 6V4's, remove the wire which connects pin 4 and lug 8 of T801, remove the wire which connects the two pins 5, run a new wire from the ungrounded pin 5 to lug 9 of T801, and add two new wires connecting pins 1 and 7 on each tube. *[Irving Megeff] Dallas Lankford added a postscript to the article – "The increasing cost and scarcity of 26Z5W's makes this suggestion attractive. The 6V4 filament is rated at 6.4 VAC 0,6 A, which means it dissipates about half the power of a 26Z5W rated at 25.0 VAC and 0.3 A. The 6V4 also has a higher maximum plate voltage rating, 350 vs. 325 VAC, and a higher maximum DC current rating, 90 vs. 75 ma."* *[Issue #17, pg 6]*

R-390A/URR PTO Alignment

The purpose of these notes is to describe an alignment procedure to achieve almost exact end point alignment of the R-390A KILOCYCLE CHANGE (PTO tuning). This procedure is similar to the method described in NAVSHIPS 0967-063-2010, the Navy maintenance manual published April 15, 1970, but is simpler because it avoids dropping the front panel. Thanks to Dick Truax for the crucial simplification, and for his general comments about PTO alignment which I have incorporated into the method below.

(1) PTO (VFO) Subchassis Removal WARNING!!!! Handle the PTO subchassis carefully to prevent damage or misalignment, do not turn the PTO subchassis shaft or the KILOCYCLE CHANGE shaft (either outside or inside the front panel). To remove the PTO the R-390A is placed upside down. If the bottom dust cover is present, remove it. The PTO subchassis is in the center of the bottom three compartments. Locate the Oldham coupler and remove the anti-backlash spring, see Figure 1 below. The Oldham coupler connects the PTO tuning shaft to the kilocycle change shaft. You will probably have to rotate the kilocycle change shaft with the front panel knob to bring the anti-backlash spring into a convenient position for removal. Do not loosen the spline socket head screws. To remove the spring I use

R-390 and R-390A Receivers

2000

a small hemostat which is ideal for delicate work like this (Hemostats are also useful for soldering and unsoldering work, holding small parts, and other tasks, and are sold through several supply catalogs and at larger electronic supply stores. Or if you know a doctor or nurse, they will probably give you one or two

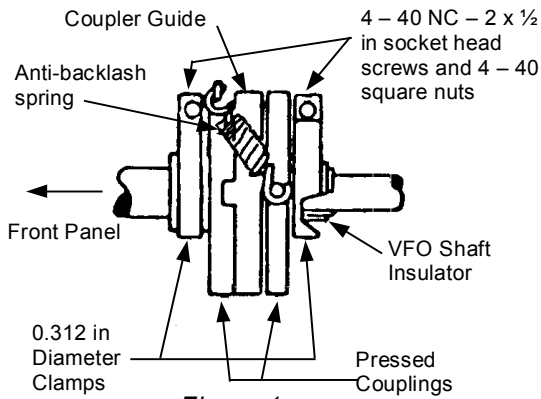

Figure 1

free.) Put the spring in a safe place and do not lose it. Next, rotate the kilocycle change knob until the Oldham coupler guide (the central disc) is in the position shown in Figure 1 (when viewed from above). At this point, if you are the careless type, you should lock the KILOCYCLE CHANGE shaft with the front panel DIAL LOCK. Disconnect the blue plug P-109 (the metal cylindrical plug cover/lock mechanism rotates to unlock, and then the blue plug can be pulled out. If you cannot unplug P-109, examine the plug closely and make sure you have unlocked it). Trace the white wire through the hole in the PTO compartment to the top side of the R-390A, unplug it from the RF subchassis (J 217), and pass it through the hole in the PTO compartment. Loosen the three green

Phillips head screws completely, and carefully lift out the PTO subchassis. Because of the positioning of the Oldham coupler, and because you have locked the kilocycle change shaft, you must lift straight up. The coupler guide will probably fall free, but in any case remove the coupler guide and put it with the anti-backlash spring for safe keeping. PTO removal can also be accomplished with the R-390A on its side, but it is not as easy to replace the coupler guide in that position.

(2) PTO End Point Adjustment Cover Removal

The location of the slotted hex nut which covers the end point adjustment control is shown in Figure 2. Older PTO's may not look exactly like Figure 2 (some do not have the same shaped cut-out holes which give access to the slotted hex nut through the front bracket of the PTO), but the position of the hex nut is the same in all models. With the appropriate size screwdriver, remove the slotted hex nut, and place it with the anti-backlash spring and Oldham coupler guide.

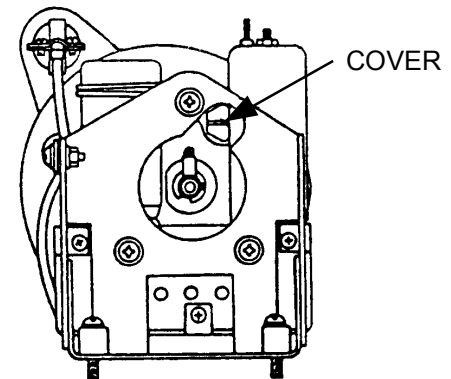

Figure 2

(3) PTO Subchassis Replacement Reverse the removal steps in step (1) above. Here if your PTO is a tight fit it may help to loosen (but do not remove) the two Phillips head screws that secure the triangular bracket towards the rear of the PTO compartment. But to tighten these two screws firmly after replacement of the PTO requires either a flexible shaft Phillips screwdriver or an offset Phillips screwdriver with appropriate head size. These two screws can be gotten reasonably tight with a straight blade Phillips screwdriver angled past the flange of the triangular bracket, but do not use much pressure or you may strip the heads of the Phillips screws. Be careful when replacing the anti-backlash spring. A little grease on the Oldham coupler guide may help hold it in place during replacement of the PTO subchassis. Again, a hemostat is very helpful for spring replacement. Make sure the spring ends seat properly in the grooves of the spring posts in the Oldham coupler. A close inspection with a flash light is probably a good idea. NOTE: If the above preliminary steps seem complicated, they are! PTO end point adjustment is not for the impatient or careless.

(4) Warm Up Turn on the R-390A and let it warm up for at least an hour. I do not normally use my crystal ovens, but if you do, remember to turn them on with the switch on the rear panel. In some

R-390 and R-390A Receivers

2000

cases, an hour may not be enough warm up time for an R-390A to stabilize. One of my R-390A's seems to require 2 – 3 hours for stabilization. If in doubt, wait longer than the recommended one hour minimum.

(5) 100 KHz Calibrator Adjustment Tune in WWV on one of its frequencies. Turn on the BFO and adjust the BFO pitch to zero beat with WWV. Turn FUNCTION switch to CAL. A het with your 100 KHz calibrator should be heard. With a small screwdriver or metal blade alignment tool, adjust C-310 through the access hole in the rear panel for zero beat. Do not change the BFO PITCH setting from the above setting.

(6) End Point Adjustment With FUNCTION switch set to CAL and BFO on (and at the same BFO PITCH position as in step (5)), set KILOCYCLE dial to +000 (a het of the BFO with the 100 KHz calibrator should be heard), tighten the ZERO ADJ. knob, zero beat by turning the KILOCYCLE CHANGE knob, and release the ZERO ADJ. knob. Set the KILOCYCLE dial to 000 (the low end of the 1000 KHz range). Again a het of the BFO with calibrator should be heard. Now comes the tricky part. Cut a plastic handled, metal blade tipped alignment tool (Radio Shack 64-2223 or equivalent) to 3-3/16 inches long – see Figure 3. The maintenance manual recommends using a non-metallic alignment tool, but I

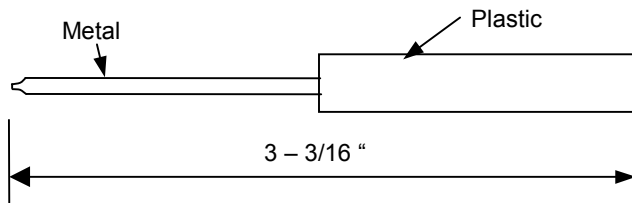

Figure 3

experienced no problems with my plastic handled, metal tipped, home-brewed tool. Slip the alignment tool through the holes in the RF subchassis front plate and PTO front bracket, and engage the end point adjustment control (slug). Good lighting is essential at first until you learn the “feel” of proper engagement. I used a flashlight to visually verify that my alignment

tool properly engages the end point adjustment slug. You should also be sure that your tool does not damage the threads which accept the end point cover nut. Some end point slugs can be turned by hand, but mine was stiff, so I used needle nose pliers to rotate my alignment tool. About 3/4 inches of the plastic handle protruded past the front plate of the RF subchassis near the ten-turn KILOCYCLE shaft stops for a good grip with the needle nose pliers. In any case, turn the alignment tool (either clockwise or counter-clockwise) until zero beat is obtained. My PTO was about 2 kHz off on the end points, and this initial adjustment required about 1/2 turn. Next turn back to +000 (the other end of the 1000 KHz range). Again, a het should be heard. Zero beat as before, using the ZERO ADJ. knob and KILOCYCLE CHANGE knobs. Tune back to 000 and zero beat with the end point slug again. Alternately repeat the +000 and 000 adjustments until no improvement is obtained. After 5 or 6 passes, you should be within 50 Hz or less. **WARNING:** Do not reverse the +000 and 000 steps during this procedure.

(7) PTO End Point Adjustment Cover Replacement Remove PTO subchassis as in step (1). Replace slotted hex head nut (refer to step(2)).

(8) PTO Subchassis Replacement Refer to step (3). NOTE: Before replacing the PTO subchassis for the final time, inspect the Oldham coupler, and clean and re-lubricate if necessary. I often use 3-in-1 oil, but you may want to use a heavier lubricant. I have also used a good quality bicycle bearing grease before with excellent results.

REMARKS: My first (and, until now, only) PTO alignment was done on a unit which was about 2 kHz off (1000 kHz actual = 1002 dial reading). End point calibration was achieved with about 1/2 rotation of the end point slug after 5 or 6 alternations of the +000 and 000 adjustments. Neither of the two PTO's I have experience with (one aligned by Dick Truax, and the other by me) are exactly linear throughout the 1000 kHz range even though the two end points in both cases are almost exactly 1000 kHz apart. After a thorough warm up, the R-390A I bought from Dick is as much as 200 Hz off at 100 kHz calibration points

R-390 and R-390A Receivers

2000

between the end points, while my other R-390A is as much as 400 hz off. Such departures from linearity should be better than 300 hz when calibrated at the nearest 100 khz calibration point. In both of my R-390A's, linearity is probably within 50 hz when calibrated at the nearest 100 khz point. In the PTO that I aligned, zero beat at 000 was obtained by rotating the end point adjustment slug clockwise (when viewed from the front). I would like to express my appreciation to Dick Truax for his patient explanations and discussions of PTO alignment. Without his advice and discussions, these notes would not have been possible.

ADDENDUM: Check the PTO tube before alignment, and replace, if necessary before alignment. I learned this lesson the hard way by replacing the tube and tube shield after end point alignment, and then learned to my dismay that the change brought the PTO about 700 hz out of alignment. [*Lankford, Issue #6, pgs 3-5*]

Cosmos PTO Alignment

I am so elated to have discovered that the Cosmos Industries PTO (blue label) has an end point adjustment! As I recall, after finding nothing to adjust under the "proper" (slotted hex bolt) cap screw, I previously neglected to look any further. The Cosmos end point adjustment is *behind* the transformer, and under a cap screw which is smaller than a regular looking screw. This small cap screw has a rubber grommet seal akin to the usual seal on the slotted hex bolt. I needed a small jeweler's screwdriver to angle into the hole after that cap screw was removed. [*Dick Truax*] *Dallas Lankford added a postscript – "Many of us had assumed the Cosmos PTO, a late model R-390A PTO, has no end point adjustment. It is merely hidden behind the Z702 transformer. When doing an end point adjustment on a Cosmos PTO, it might help to remove the Z702 shield."* [*Issue #13, pgs 3,4*]

R-390A PTO Adventures

Having read and re-read Dallas' article on the task in HSN 6, I was deeply into realigning the PTO on my 1962 R-390A. He cautions us to avoid moving the PTO shaft when removing the PTO. Well, in the excitement of it all, I must have moved it a lot. When I put it back in after removing the end point adjustment screw cap, I couldn't get a het for love or money at the +000 point like one is supposed to. Yegads. This was my first at doing anything more technical than changing tubes, and being slightly over-awed by electronic gadgetry, I was miserable. I thought about it for a few days, and then realized I had probably moved the PTO shaft. If I ruined the alignment by moving the shaft, then I reasoned I could fix it by moving the shaft in the opposite direction. But I didn't know which way I had turned it. Well, I couldn't mess it up any more, so I went back in and started over. I dialed up +000, locked the zero adjust, and after a few deep sighs, gripped one of the prongs on the Oldham coupler with needle nose pliers, and turned the shaft. Sure enough, after some movement of the shaft, zero beat emerged. At that point I resumed the normal procedure for aligning the PTO and everything went well. Thanks to Dallas for the instructions. They are a lot better than the NAVSHIPS instructions which are downright misleading. [*Fritz Melberg*] *Dallas Lankford added a postscript – "Your contribution is excellent because it should encourage other beginners to learn more about their receivers. The mistake is very common, and I have made it several times myself. Here are some tips to overcome this mistake. With the R-390A on its side, the blue PTO plug and miniature coax connector attached, but the center disk of the Oldham coupler and tension spring removed so that the PTO shaft turns independent of the KCS knob, turn on the receiver and tune around the BCB with the KCS knob until strong signals or background noise are located. Then tune slowly up or down to +000, alternating between the KCS knob and the PTO shaft. You may want to wait*

R-390 and R-390A Receivers

2000

until night when there are plenty of strong BCB signals. If you have not been too careless, you should find strong signals or background noise on band 1 between 900 and 1000 kHz, or in the 1000 to 1035 over-range. This procedure can also be used to locate the frequency of almost any PTO set to an unknown frequency. Depending on the PTO frequency, you may have to switch between bands 1 and 2 to make it to +000 on band 1. Be sure to find the PTO frequency by turning the KCS knob first. The reverse procedure can be disastrous. If you turn the PTO shaft too far in the wrong direction you can damage internal PTO parts [Issue #18, pg 6]

The R-390A On Longwave – Cheaply

The R-390A is a fine receiver, and many of us are quite familiar with it. A major drawback is that it doesn't tune below 500 kHz – or does it? A look at the schematic shows that the local oscillator is the 500-1000 kHz range does indeed track from 500 down to 0 kHz. Working backwards from the first mixer we find the first and only bottleneck. The antenna coils and RF amplifier tuned circuits are the culprits. They stop at 500 kHz and go no lower.

As an experiment, I removed the top covers from my R-390A and coupled a longwire antenna through a 0.05 mf capacitor to “test point E-209.” This is easily accessible from the top and is found just in front of V202, the first mixer. Voila! Most of my strong local LW stations were heard, along with an assortment of BCB spurs, IM products, and other electronic garbage. The spurious responses were to be expected because there was no tuned circuit between the antenna and first mixer. Next came some preselection in the form of a ferrite loop antenna. The loop output was connected to E-209 with a piece of small coax and the 0.05 mf capacitor. This gave greatly improved results. There were very few BCB spurs, and in improvement in sensitivity. Apparently the loop compensated for much of the lost R-390A RF amplifier.

A variation of the first experiment gave better results, practically equaling the performance of a Drake R-7A used for comparison. An old coil from a 1939 vintage RCA BCB transmitter was found in the junk box. This is a large coil, with 70 turns of #16 solid wire around a 6.5 inch ceramic and phenolic coil form. A smaller coil of 19 turns was mounted inside it. This small coil was rotatable to vary the coupling. Older members of our fraternity will recognize this as a variometer, common in the early days of radio but seldom seen nowadays. In this particular unit, the coil had taps on every other turn. A 10-440 pf variable capacitor, also from the RCA transmitter, was used to resonate the circuit. The long wire antenna coax was connected to the smaller, rotatable coil, and the variable capacitor was connected to a tap about 75% up the main coil from ground. A tap point two turns from the ground end was selected as the feed point for E-209. Optimum coupling between the small inner coil and the large outer coil varied from maximum at 200 kHz and below to a very small coupling value at 400 kHz. This may be more of a function of the antenna used than anything else. Unfortunately, the 1939 RCA transmitter parts are difficult, if not impossible, to find. Perhaps an equivalent circuit could be constructed with a ferrite toroid. A suggested

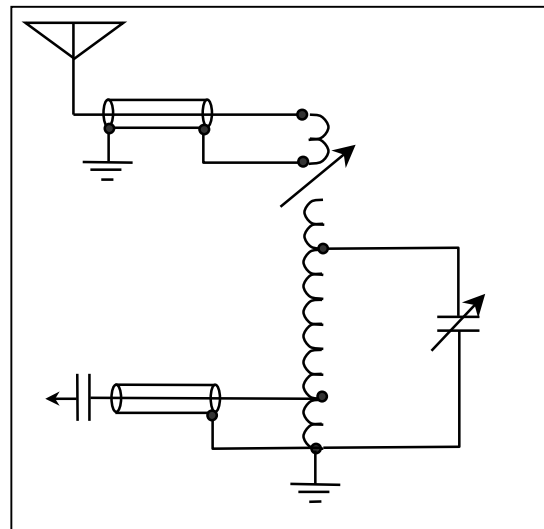

R-390 and R-390A Receivers

2000

schematic is given to the left. The toroid should have two windings – a main coil with taps to adjust the frequency range and feed E-209, and a second winding with taps for varying the antenna coupling. As a starting point, use turns ratios like those mentioned above. The shield of the long wire coax can be left ungrounded, only connected to the coil ground. I have experienced some noise reduction when connecting the coil and long wire coax in this manner. However, the far end of the coax should be grounded. I have used an antenna tuner identical to this on the BCB with good results. [*Healy, Issue #2, pgs 3-4*]

Speaker Impedance Matching

If you are having difficulty in getting good audio from an 8 ohm speaker because the government in its infinite wisdom chose another impedance (600 ohms), try a 115 VAC to 12 VAC power supply transformer such as those sold at Radio Shack. Connect the primary (black) wires to your receiver and the secondary (red) wires to your 8 ohm speaker. [*Arey, Selected Reprints From Numbers 1-4, pg 4*]

Some people who use R-390A's complain about hum, low audio output level, and poor frequency response. However, an R-390A has excellent audio quality and enough audio output power to drive you out of the room when used with an appropriate audio transformer which matches the 600 ohm audio output impedance to a speaker or headphones. The purpose of this note is to discuss appropriate audio impedance matching transformers for use with an R-390A.

The usual reason for hum and low audio output level with an R-390A is that low impedance headphones and a low impedance speaker, usually 8 ohms, are used without an audio transformer to match the 600 ohm audio output impedance to the low impedance load. A common cause of poor R-390A audio frequency response is the use of a military surplus LS-166 speaker. It has a built-in 600 to 8 ohm audio transformer and 8 ohm speaker, but the audio transformer has a limited frequency response of 350 to 3500 Hz. The LS-166 and similar speakers are designed for voice reception only.

The R-390A local audio output is rated as 500 milliwatts with less than 10% distortion into a 600-ohm load, and 1 milliwatt into a 600-ohm headset. The line output is rated as 10 milliwatts with less than 6% distortion into a 600 ohm balanced line. Measured maximum local audio output power before clipping is 1 watt into a 600-ohm load. Measured local audio frequency response is approximately flat from 100 to 10,000 Hz, and drops off slowly below 100 Hz and above 10,000 Hz.

One of the best ways to match the 600-ohm audio output impedance of an R-390A to low impedance headphones or a low impedance speaker is to use an audio line transformer. Line transformers come in two varieties – 25-volt line transformers, and 70.7 volt line transformers. They are designed for use with public address and audio distribution system. The 25-volt line transformers are intended for use with amplifiers which have a 25 volt RMS maximum output, while the 70.7 volt line transformers are intended for use with amplifiers which have a 70.7 volt RMS maximum output. The 25 volt line transformers typically have primary taps with impedances which are multiples or fractions of 625 ohms (equivalently multiples or fractions of 1 watt). The 70.7 volt line transformers typically have primary taps with impedances which are multiples or fractions of 5000 ohms (equivalently multiples or fractions of 1 watt).

Currently I use a 25-volt line transformer, Stancor type A8089. The Stancor A8089 has primary taps marked 4, 2, 1, and 1/2 watt, and a secondary marked 8 ohms. Since the primary taps of a line transformer are often specified in watts, you will have to convert the watt ratings to ohms. For example, using the formula $R = V^2/P$, where R is the impedance in ohms, V is the voltage rating in volts RMS, and P is the power rating in watts, it follows that the 1/2 watt primary tap is $R = 625/0.5 = 1250$ ohms, and similarly that the 1, 2, and 4 watt primary taps are 625, 312, and 156 ohms respectively. For a 70.7 volt

R-390 and R-390A Receivers

2000

line transformer with primary taps of 10, 5, 2.5, 1.25, and 0.62 watts, the equivalent primary impedances can be calculated as 500, 1000, 2000, 4000, and 8000 ohms respectively.

In my experience, it does not make any significant difference whether you match the R-390A 600-ohm audio output impedance with the 625 ohm primary tap of a 25 volt line transformer or the 500 ohm primary tap of a 70.7 volt line transformer. In fact, you can use a 1000-ohm or 1250-ohm primary tap of a line transformer; the only noticeable effect is a small decrease in maximum available audio output power.

The Stancor A8089 transformer is no longer available from Fair Radio. You might find it acceptable to use the Radio Shack 70-volt line transformer, catalog number 32-1031, for \$5.95. The Radio Shack transformer has primary taps of 10/5/2.5/1.25/0.62 watts and secondary taps of 4/8/16 ohms.

My current audio impedance matching adapter is shown in the following schematic. I used both the

625 and 1250-ohm primary taps of the Stancor A8089. I cut off the two extra primary tap leads flush with the primary windings. A 1-megohm half-watt resistor was used to provide a tape output. The transformer was mounted in a small

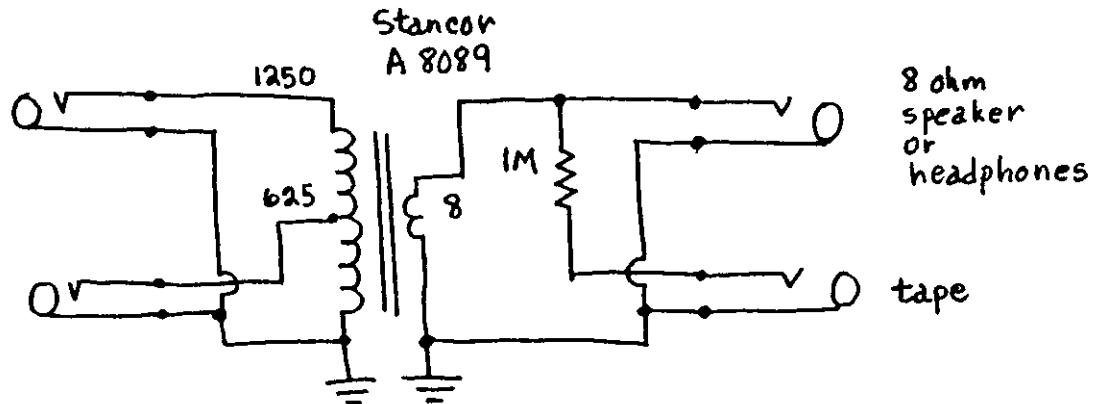

metal box with four standard 1/4-inch headphone jacks for input and output. Audio cables with standard 1/4-inch headphone plugs are used to connect the adapter to a speaker or to the headphone jack of the R-390A or other receiver. A home-brew audio cable with headphone plug on one end and lugs on the other end is required for connecting the adapter to the terminal strip on the R-390A rear panel. You should note that terminal 7 on the R-390A rear panel is audio ground. If you connect the mating audio cable incorrectly, you may experience a strong shock when handling the adapter box or audio plugs, or you may accidentally short circuit the R-390A audio output. For speaker use, the audio cable center conductor should go to terminal 6, and the audio cable braid should go to terminal 7 on the R-390A rear panel terminal strip.

The 625-ohm primary of my adapter is used with an R-390A. The 1250-ohm primary is used with the high impedance headphone jacks of other receivers, such as a Hammarlund HQ-180A or HQ-150.

Perhaps it is appropriate to mention here that I have observed unnecessary replacement of power supply electrolytics in two HQ-180A receivers, probably as a consequence of unsuccessful attempts to eliminate hum from headphone audio output. In one case, new electrolytic capacitors were dangled from the wiring which had been disconnected from the original metal can multi-section electrolytic. In another case, an intermittent loss of B+ power was traced to unsoldered connections at the multi-section electrolytic lugs; the unsoldered leads had been stuck back through the solder lugs without re-crimping and resoldering them. After the careless and unnecessary tamperings had been repaired, and an audio impedance matching adapter was used, the headphone audio output of these two HQ-180As was excellent. While I am on the subject of good audio from hollow state receivers, let me remind you of the Radio Shack Indoor/Outdoor 4" speaker in the ugly plastic case, catalog # 40-1227A, mentioned in a previous HSN. It is still the best speaker I've found for use with hollow state receivers. Has anyone tried the 6-1/2" catalog #40-1248? For

R-390 and R-390A Receivers

2000

headphones it is hard to beat the Radio Shack Lightweight Monaural Headphones, catalog #20-210A, provided you cut off the 1/8" plug and replace it with a standard 1/4" plug. (The 1/8 to 1/4" adapter supplied with the headphones introduces static.) [Lankford, Issue #26, 10/90, pgs 2,3]

Dating of R-390A's

Determining the age of R-390A's is as simple as looking at the date stamped on the filter capacitors C-606 and C-603 on the AF subchassis. They are generally stamped with a month and year, e.g. 6-67. Also, you might look on C-103, the metal capacitor fastened to the back underside of the chassis behind the main PTO. You could also look on the crystal oven on-off switch S-106. [Truax, Issue #4, pg 2] *Please be aware that this is not foolproof as the original modules containing these parts may have been swapped out during maintenance. It is entirely possible that your R-390A is comprised of modules from several different manufacturerers and with different dates. Al;so, the individual components may have been changed on the modules.– Ed.*

Alignment of the R-390A

The technical manual notwithstanding, an R-390A can be aligned using only the calibration signals and the LINE LEVEL meter, with the RF GAIN control retarded to keep the signal strength down. Use the calibration points nearest the receiver dial readings called for in the alignment procedure. Do not overlook the first crystal oscillator tuning, T-207, which can be peaked for maximum on any frequency below 8 mHz. Do not attempt alignment of the 455 kHz I.F. transformers. Performance of the three mixers varies considerably with various 6C4 tubes. If possible, try several in each socket and retain the tube giving highest gain. Although the technical manual calls for 3 microvolt sensitivity, a well-manicured R-390A will get down below 0.5 microvolt. [Cornelius, Issue #4, pg 4]

Input Impedances and Connectors

The UNBALANCED input jack is at a high impedance and works very poorly with coax or with any but a short antenna. The R-390A will work well only through its balanced (2-pin) antenna input, with the antenna (center conductor of coax) connected to one pin and with the other pin connected to ground. This can be jury-rigged if necessary but the best approach is through use of a connector designed for the purpose. A UG-970 or UG-971 connector will mate with the two-pin socket. The UG-971 adapts to a type C connector such as the UG-709 (for RG-58/U cable) or UG-636 (for a UG-88/U BNC connector). The UG-970 adapts to the PL-259 UHF connector. In any case, check the three connectors on the antenna relay box inside the R-390A to be sure that each cable is connected to the correct jack. [Cornelius, Issue #4, pg 4]

Mechanical Filter Protection

One of the more expensive and difficult to replace items in the R-390A are the mechanical filters. The only thing separating the filters from some 195 VDC at the plate of V-501 is capacitor C-553.

Go inside your IF-subchassis and check capacitor C-553. It is a 0.01 mf paper unit that has a rather low voltage rating; it frequently shorts out and TAKES THE MECHANICAL FILTER IN USE OUT WITH IT!. To compound matters, the author knows of one fellow R-390A user who, discovering his set was dead, proceeded to switch to various bandwidths in an attempt to get audio, thereby popping ALL of the precious (and terribly expensive) filters because C-553 has shorted out. It is recommended to replace C-553 with a 400 V or 600 V Orange Drop mylar capacitor. [Nelson, Issue #5, pg 1]

R-390 and R-390A Receivers

2000

The original article in HSN #5 referenced a C-533 which is incorrect. The origin of this error goes back to the Army manual (TM 11-5820-358-35) on pages 68-69 where Figure 41 has the C-553 capacitor mislabeled as C-533. C-533 is really off in the BFO circuit somewhere. HSN #6 added the following correction and supplementary advice from Dallas Lankford.

To begin with, Dallas suggests using a .01 1000V disc ceramic capacitor, although he notes that anything in the .01 to .1 range with a voltage rating of 600V or better will do. Dallas goes on to note that there are actually two paths to ground – one from one of the mechanical filters, and one from the ground of the trimmer caps. The ground from the mechanical filters was rerouted to the grounds of the trimmer caps, and the path from the trimmer caps to the chassis ground was replaced by one of the above-valued capacitors. The point of the modification as Dallas does it is that you now have two caps protecting the mechanical filters, so that if one cap shorts the other cap still protects the mechanical filters.

R-390A AGC Time Constant Repair

After about 15 minutes of warm-up, the receiver gradually lost all ACG in the slow setting and partially in the medium setting. Checking with my VOM, I found that C-551, an electrolytic cap in a metal can shield on the IF subchassis was defective, measuring only about 250K ohms resistance and passing a DC current. In repairing this defect, I purchased a 2-mfd, 400 VDC. To preserve the ‘ambience’ of the R-

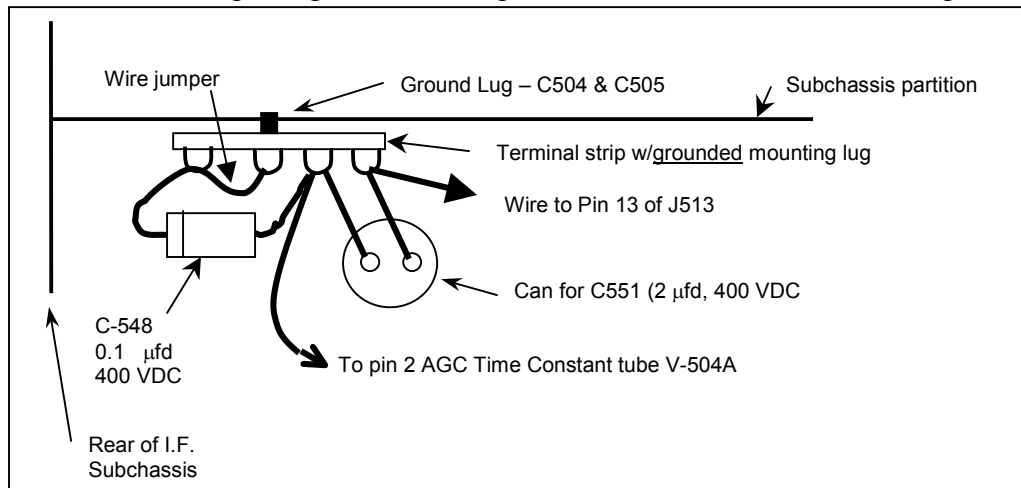

390A, I pulled off the contacts of the original capacitor, drained off the fluid, desoldered the can, and, after carefully insulating the new capacitor leads and lining the can with heavy cardboard, place the new cap in the can and sealed it with silicone cement. Perfect fit! It is necessary to solder wire extensions onto the cap

leads, and these were taped to the body of the cap with good plastic tape. In making this repair, I also replaced C-548 with a new 400 VDC mylar-type unit. It is physically in the way and is rated at 100 VDC. In order to insure good mechanical rigidity, it seemed wise to mount a terminal strip on the chassis partition where C-504 and C-505 are grounded. A diagram is above. [Murphy, Issue #9, pg 4]

Dynamic Range - R-390A versus NRD-515, R-7A & R-70

If you have ever wondered how the R-390A dynamic range compares with other general coverage receivers, Sherwood Engineering (1268 South Ogden St., Denver CO 80210) has provided some answers. The first page of their general catalog lists 38 receivers from which I have selected seven general coverage and seven Ham receivers/transceivers, together with some of Sherwood’s measurements.

R-390 and R-390A Receivers

2000

The following abbreviations are used in the tables below: NF = noise floor (dBm); B = blocking (dB); S = sensitivity (microvolts); FS = filter stopband (dB); SS = test signals spacing; WDR = wide dynamic range (dB, 20 kHz SS); NDR = narrow dynamic range (dB, 2 kHz SS); S1 = 100 kHz SS; S2 = 50 kHz SS; S3 = 5 kHz SS; S4 = 3 kHz SS; S5 = 2.5 kHz SS; F = modified with Sherwood filter; T1 = receive tuning range 1.5-5 and 6-30 mHz; T2 = receive tuning range 2-5 and 6-23 mHz; T3 = receive tuning range 3.4-5 and 6.5-29.7 mHz; H = Ham bands only; and G = general coverage receive.

GENERAL COVERAGE RECEIVERS

Model =>	<u>R-390A</u>	<u>NRD-515</u>	<u>R-7A</u>	<u>FRG-7700</u>	<u>R-1000</u>	<u>NRD-93</u>	<u>R-70</u>
NF	-137	-138	-135	-130	-130	-141	-129
B	130	103	145	123	119	128	132
S	0.2	0.1	0.3	0.2	0.2	0.15	0.4
FS	>85	>80	>85	>65	>70	>80	>90
WDR	81	95	97 ^{S1}	83 ^{S2}	76	94	86
NDR	79	77	75	64 ^{S3}	64 ^{S4}	63	62 ^{S5}

Model =>	<u>R-4C</u> ^{T1}	<u>350-XL</u> ^{T2}	<u>TS-830</u> ^H	<u>901-DM</u> ^H	<u>IC-720A</u> ^G	<u>TS-820</u> ^G	<u>75-S3B</u> ^{T3}
NF	-139	-131	-129	-135	-137	-137	-146
B	133	117	122	124	138	115	122
S	0.15	0.2	0.1	0.15	0.15	0.2	0.1
FS	>140 ^F	>95	>85	>85	>80	>80	>85
WDR	85 ^F	81	84	87	93	79	88
NDR	85 ^F	81	81	80	78	78	74

Dynamic range measurements were made using two equal strength test signals, nominally 20 kHz apart for the wide measurements, and 2 kHz apart for narrow measurements. In some cases, because of filter band widths or synthesizer noise, wider test signals separations were used. With all other things being more or less equal, high narrow dynamic range is the deciding figure of merit for ranking a DX receiver. Notice especially that the wide dynamic range figures are frequently not good indicators of narrow bandwidth performance. As we see above, the R-390A wins first place for narrow dynamic range performance against the best of recent solid state general coverage receivers. Sherwood Engineering does not provide measurements for any other tube type general coverage receivers. [Lankford, Issue #11, pgs 5-6]

Meter Lighting

I was unhappy with the lack of meter lighting in my R-390A, and feeling adventurous, I installed small 5 volt 50 ma lamps inside the meter cases. A schematic of the meter lighting mod is given below. First, remove the meters from the receiver, tagging leads. This can be done without removing the front panel with patience. Remove the front plates from the meters, and then gently remove the circular glass plates. They may be cemented, so be careful not to break the glass. I used a tiny jeweler's screwdriver to gently pry the glass plates loose. After the glass plates are removed, the meter movements can also be removed and set aside out of danger.

R-390 and R-390A Receivers

2000

In my meters it was necessary to clip off a small appendage on the movement spring to make room for the lamp near the very front of the case. A small hole is drilled through the rear of the metal meter case for the wire and lamp installation. I took AC power from the low voltage end of R124 which is a dropping resistor for the main dial lights. It is located on TB101 on the front panel, and the connection can be made without front panel removal. I used a series connection with a 12 ohm ½ watt series dropping resistor, hoping to reduce any heat generated (none is apparent), and obtain long lamp life since replacing them will obviously be a pain. I placed the 12 ohm resistor at the end of the line, and grounded it to a solder lug attached to the line level meter mounting screws. Paint on the front panel must be scraped off to make a good electrical contact. It sounds complex, but it isn't – just don't try to hurry. [Murphy, Issue #12, pg 3]

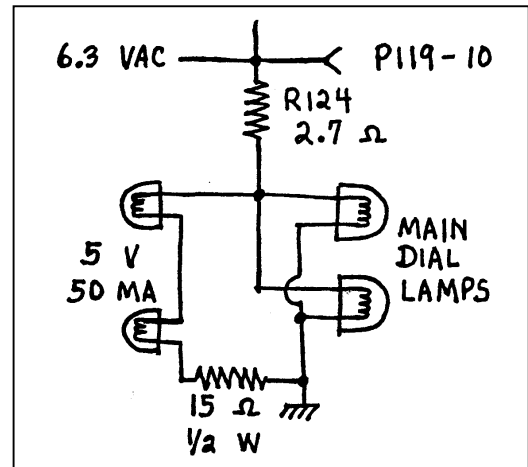
**Radioactive Meters**

Several people have written us lately expressing concern about the radium dials on R-390A meters. It is, of course, understandable that there would be some concern. Three Mile Island and Chernobyl have entered the world's collective consciousness. Rather than make too light of a possible serious problem, Dallas began to collect some facts. First, an R-390A user in Ruston, Rick Burns, just happened to have a version of TM 11-5820-358-20 with "Changes 2 Throught 4" which lists several radiation sources in the R-390A and gives activity numbers. There are apparently at least two meter models with different Ra226 activities, one rated at 0.69 μCi , the other 0.40 μCi . To determine what that meant, and to measure radiation dose rates of typical meters, Dallas took line and audio meters to the Nuclear Center at Louisiana Tech University where the director and Dallas measured the dose rate with a sensitive, calibrated, radiation meter. Both meters measured less than 0.5 mR/hr at about 1 cm, i.e., with the radiation meter "window" pressed flat against the front surface of the R-390A meters. According to *The Code of Federal Regulations*, 1987, section 414, the "Permissible Levels Of Radiation From External Sources In Unrestricted Areas" is 0.5 R/yr, 100 mR/week, and 2 mR/hour for adults (over 18 years old), and 1/10 of these values for minors (under 18 years old). An R-390A with two meters typically will not exceed the permissible hourly radiation level. But the radium paint on these meters was applied by hand, so some meters might exceed the permissible hourly radiation level. However, under normal operating conditions you will receive a much smaller radiation dose from your R-390A than permitted by 1987 law. Radiation is inversely proportional to the square of distance, so at 10 cm (about 4 inches) from the front surface of a meter the dose rate is about 5 $\mu\text{R}/\text{hour}$, or about 100 times less than at the front surface. If you used your R-390A 8 hours per day for one year with each meter an average of 4 inches from your body, then you would typically receive about 1/25 of the radiation permitted by 1987 law. We can't tell you that the meters are safe because some authorities say that no amount of radiation is safe. And you should definitely not open the sealed meters and handle or ingest the Ra226. If you want to dispose of your R-390A meters without breaking federal laws, you will need to study *The Code of Federal Regulations* for the current year. It is available at many university libraries. We do not intend to remove our meters from our R-390A's or dispose of them [Hanson and Lankford, Issue #19, pg 4]

R-390 and R-390A Receivers

2000

Radioactive Tubes

Just as soon as we breath a sigh of relief, the radioactive bugaboo appears again, this time in the 0A2WA. There are at least three different manufacturers of radioactive 0A2WA's and each used a different isotope. EEVC used Uranium 238 with a rated activity of 0.1 μCi , CBS-Hytron used Nickel 63 with a rated activity of 0.5 μCi , and Ratheon used Cobalt 60 with a rated activity of 0.2 μCi . I had a CBS-Hytron 0A2WA on hand which I carried to be measured, but I could have left the tube at home if I had remembered by long forgotten undergraduate university physics. Ni63 is a β emitter, and β 's can't make it through the glass envelope. The radiation meter detected no radiation from my 0A2WA. A curious point which emerged from our discussions is that the half lives of these three isotopes are radically different – 4.5 billion, 100, 5.27 years respectively for U238, Ni63 and Co60. If the radiation is important for operation of the 0A2WA, then Ratheon 0A2WA's made in the 1950's and 60's are probably duds now. And if the radioactivity is not important, why were radioactive isotopes used in the first place? We could not measure typical dose rates of the other two types of 0A2WA's because I have none on hand. Glass tubes are not nearly as sturdy as R-390A meters, so the wise individual will probably gently remove any 0A2WA's from his R-390A's and use non-A 0A2W's or 0A2's [Burns and Lankford, Issue #19, pgs 4, 5]

Tube Substitutions

Since the earliest issues of HSN, various R-390A tube substitutions have been offered by readers. By and large, I personally subscribe to the 'use what's specified' school and don't normally use subs, unless I have a failure and don't have a direct replacement. I have scoured the local ham fairs and replacements for most of the R-390A tubes are still readily available at a reasonable cost (exceptions are the 26Z5W's and the 3TF7 which only appear to be available from commercial sources). For those of you who are interested in substitutions, here is a summary of contributions. The first ones listed are reputed to be the 'best' ones and some are direct replacements as per current tube substitution handbooks; a tube substitution handbook is a handy item to have around the shack. 4-digit numbers are are military ID numbers. – Ed.

Original	Substitutions
6DC6	6BA6/5749, 6BZ6, 6BJ6, 6BJ6A, 6HQ6, 6HJ6, 6GM6, 6662
6C4W	6C4, 6C4WA, 6J6, 6135, 6AB4, 6DS4, 6101
5814A	5814, 5814WA, 6680, 7730, 12AU7, 12AU7A, 12AU7WA, 12BH7A, 12AT7, 12AT7A, 12AT7WA, 7316, 6B 6189, 6189, 6067
5654	5654W, 6AK5, 6AK5W, EF95, 6096, 5591, GB 408A, 6028, 6968
5749	6BA6, 6BA6W, EF93, 6660, 6AH6, 6HR6, 6AU6, 6AU6A, 6HS6
6AK6	6AU6, 6BA6, 6HR6, 6HS6, GB 5136, 7543
0A2	0A2WA, 6073, 6626, 6930
26Z5W	none
3TF7	3TF11

External Product Detector Modification

The November 1985 issue of *Ham Radio* contains an article "External product detector improves receiver performance," by A. Nusbaum, W6GB, which includes an R-390A mod claimed to improve sensitivity and noise figure. Part of this mod includes removing the IF transformer shields, clipping the Q-reducing resistors which are in parallel with the tuned circuits, and peaking all IF transformers on 455 kHz. This does not seem desirable for several reasons. One purpose of the Q-reducing resistors and stagger-

R-390 and R-390A Receivers

2000

tuned IF transformers is to provide a flat IF response, especially in the 8 and 16 kHz bandwidths. Tampering with the original design may degrade flatness and increase signal levels at the detector (which in turn may degrade strong signal handling performance). I suggest that this mod **not** be done for those reasons alone. Also, clipping the IF transformer resistors can bend the internal IF transformer wires so much that they touch the shield, causing reduction or loss of gain. I encountered just such a problem recently. For about a year I had been trying to find a problem in a spare IF subchassis which manifested itself as an intermittent decrease in AGC voltage, and decrease in sensitivity. But all tube voltages and resistances measured normal (as compared to a known good IF subchassis). The intermittent nature of the problem made it extremely difficult and time consuming to trouble shoot, so I had slowly begun to replace every capacitor on the IF subchassis under the assumption that the problem was caused by an intermittently bad capacitor. A few weeks ago I had removed the IF transformer shields to make a record of the values of the Q-spoiling resistors, and on close examination I discovered to my amazement that some of the resistors had been clipped on one side, and that the internal wiring had been bent slightly outward. After repairing the damage, no further problems have been experienced. Enough said? Just for the record, older IF transformers usually have 47K ohm resistors for R511, R512, R553, and R554, and 82K ohms for R522, while newer units have 39K ohms and 68K ohms respectively. Incidentally, do not change the resistors in your IF subchassis. Apparently there are at least two different IF transformer coil windings, "old" and "new", and the resistor values are different by design. The intermittent gain reduction problem may also occur with "mint" IF subchassis. If someone has carelessly handled an IF subchassis, the IF transformer shield may have been bent slightly inward so that the internal wires touch the shield. An easy cure is to wrap a turn or two of insulating tape around the internal structures (in particular where the solder joints protrude) which might touch the shield. El cheapo black vinyl electrician's tape will work, but I prefer Scotch 27 glass cloth electrical tape. *[Lankford, Issue #13, pgs 2,3]*

Use of STAND-BY Function Setting

The Operator's Manual, TM 11-5820-358-10, warns on page 24 not to leave the R-390A in STAND BY for more than 30 minutes because the life of certain tubes may be shortened. If I have read the R-390A schematic correctly, the "certain tubes" above refers to the PTO tube and the audio tubes. I have also discovered that the nominal 240 (RF and IF) and 205 (audio) VDC lines have considerably higher voltages under various signal levels and function settings (STAND BY/AGC/MGC/CAL). The highest voltages occur in STAND BY, namely 271 and 256 VDC respectively for one of my units with a solid state power modification and recommended 200-ohm dropping resistor. This means the 205 VDC line is about 51 volts high, while the 240 VDC line is about 31 volts high when on STAND BY. The potential damage to RF and IF tubes, except the PTO tube, is not great because the function switch turns off the nominal 240 (=271) VDC line to most RF and IF tubes. But the audio line is not switched, so all audio tubes are operated at 256 VDC when on STAND BY. The audio output tubes are operated far beyond their ratings, which undoubtedly contributes to their reputation for frequent failures. Incidentally, without the 200 ohm dropping resistor, the RF B+ line can easily exceed a whopping 300 VDC. All of these unhappy facts have caused me to reject the solid state power supply conversion, and unmodify my R-390A's back to twin 26Z5W rectifiers. *[Lankford, Issue #16, pg 4]*

Miniature Coax

The nomenclature and specifications for the miniature coaxial cable for the IF output jack and other locations is RG-187U according to the NAVSHIPS 0967-063-2010 technical manual. I finally got tired of looking at the cracked insulation and frayed shield on one of my PTO's, so I bought some RG-187AU. The

R-390 and R-390A Receivers

2000

main difference is that the U type has a solid center conductor, while the AU has a stranded center conductor. If memory serves me correctly the RG-187AU is rated as 95 ohms nominal and about 20 pf capacitance per foot. One problem I encountered is that you can only purchase a 100 feet minimum of RG-187AU, which came to about \$100. It is very high quality mil spec: the center conductor is 7 strands of silver-plated #38 steel wire, white teflon insulation, silver plated stranded shielding, with two layers of white teflon tape outer insulation. The center strands are very easy to cut or break while “dressing” the cable for use, and it helps to use a magnifying glass while you count center strands to make sure you haven’t cut any while removing the center insulation. It weighs 1/5 ounce per foot. [Lankford, Issue #16, pg 5]

Synchronous AM Detection

HSN # 17, 18 and 19 provided an ongoing discussion and development of a rather simple and straightforward method of adding AM synchronous detection to the R-390A. Here are the three articles edited for clarity.

In HSN #17, Graham Maynard describes his basic circuit as shown in Figure 1. “Only two wires have an direct electrical connection with the set; an end of the wire attached to one of the 100K resistors

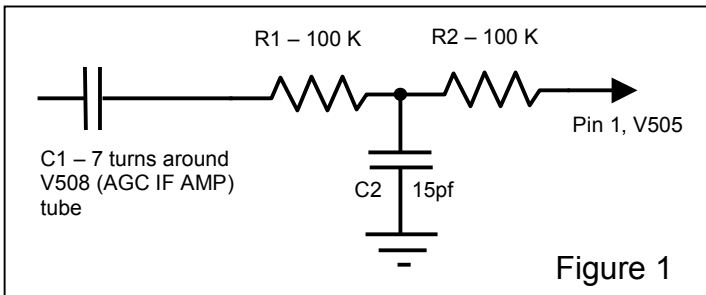

was pushed down pin hole no. 1 of the BFO oscillator socket, V505, and one lead of the 15 pf capacitor was grounded beneath a screw which secures the BFO PTO mounting bracket. The resistors were connected in series, and the other capacitor lead was soldered to the junction of the two resistors. A wire from the other end of the series resistors was neatly wrapped 7 times around the AGC amplifier tube V508 and knotted

in place. The set and BFO were turned on. “Wow, what a circuit!” I had in front of me a fully synchronous AM receiver that locked onto weak carriers long before they could otherwise be detected, and rejected adjacent channel signals. It was less effected by splatter and impulse noise, did not suffer carrier related propagation or receiver passband filter distortions and had a useful noise limiter. The BFO was both AM resolver and SSB CIO; tune first then BFO resolve. Bit of the Irish? Don’t doubt me, the circuit works. It is non-intrusive and a real champ. The 7 turn wrapping of V508 creates C1. C1 taps the carrier, C2 shifts phase.”

Dallas Lankford adds: “I must admit, Graham, that I doubted you. But I was so intrigued by your circuit that I rushed home and added one to an R-390A. By golly, it works, and works very well indeed! I didn’t have a 15 pf capacitor on hand , so I used a 10 pf 500 VDC NPO. I also used half-watt resistors, and no. 22 stranded insulated wire. At first I had a little difficulty replacing the BFO tube with the wire inserted in pin no. 1 of the BFO socket – I had twisted the strands making insertion of tube pin 1 difficult, and I initially ran the wire between the tube and the tube socket skirt, which caused binding. After a few moments thought, I untwisted the strands (about 5/16-inch insulation removal allows complete insertion of the strands into the pin hole), and ran the wire through a small cutout on the side of the tube socket skirt. The tube then inserted easily, and though the tube did not seat completely because of the insulated wire between its bottom and the tube socket base, good contact was made with all tube pins. The stranded wire to pin 1 was 6 inches long (it could have been shorter), and the stranded wire to the 7 turn wrapping of V508 was 24 inches (including a couple of extra inches which can be removed after wrapping). The resistors and capacitor were soldered in a “T” configuration, with short leads. The resistor leads which

R-390 and R-390A Receivers

2000

attach to the stranded insulated wires were also cut short. But the ground lead of the capacitor was kept full length, with a hook bent into the end for sliding under the grounding screw. I tested the circuit first on

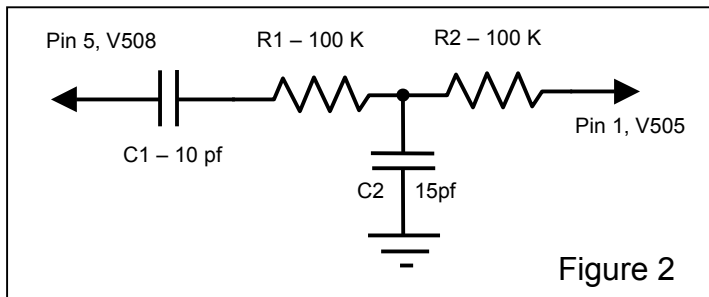

strong local and semi-local MW stations about 3 pm local time. Adjusting the BFO to zero beat was delicate, but not excessively so, and long term stability was found to be very good, on the order of 5 – 10 minutes or longer. Both DSB (BFO frequency in the center of the mechanical filter passband) and SSB (BFO frequency at either edge of the mechanical filter passband) were tried. For SSB mode it seemed that best results were

obtained when the signal carrier was no more than 20 db down on the mechanical filter skirt. Next, I tuned around the SW broadcast bands, listening mainly to weak signals with strong fading. In those cases the synchronous detector seemed to give the most improvement in DSB mode because DSB minimized audio variations due to fading. But I really don't have enough experience with the synchronous detector yet to draw any firm conclusions, and there are likely instances where USB or LSB would be better. All of my R-390A IF's have the Cornelius SSB modification, which may or may not cause performance differences between your receiver and mine. For example, I did not observe the noise limiting effect that you mentioned. However, your synchronous circuit is definitely a winner and certainly improves AM reception on strongly fading signals and on signals where SSB reception is desired because of interference on one sideband. I was so excited by the excellent results with this circuit that the next morning I dropped off a schematic at my colleague's office. Dr. Tom Williams, currently an electrical engineering professor here at Louisiana Tech University, has many years experience as a radio design engineer for some of the major USA electronic firms, including Collins Radio (now a division of Rockwell) and E Systems. Tom tells me that this circuit is called an injection locked oscillator, and that he played with the idea some years ago in a more sophisticated form using external transistor circuitry to implement a phase locked loop in a National NC-183D to which he had also added mechanical filters. Based on hints from Tom, and a peek at my copy of Radiotron Designer's Handbook, it seems to me that the circuit is essentially a low pass RC filter with parameters selected to pass a 455 kHz signal. That afternoon I tried a direct connection using tube test sockets and a 10 pf 500 VDC NPO for C1 (see Figure 2). It worked as well as the original. I also tried moving the RC filter input to the 4th IF, V504. It did not seem to work as well – BFO tuning seemed more critical. This means that to make the original circuit a permanent addition to an R-390A will require running a wire from the "AGC compartment" of the IF subchassis to the "IF amp compartment," a non-trivial task because you must either drill a hole in the metal plate that separates the compartments or pass the wire through the difficult-to-access existing hole that passes the existing wires. Miniature coax should probably be used. The next day I tried the injection locked oscillator circuit with an HC-10 converter to determine the feasibility of using it in an HQ-180A. It worked well, with one exception – the HC-10 drifted so badly that signals lost lock after a very short period, say 15 seconds. Oh, well This indicates that the remarkable stability of the R-390A is a crucial factor in the success of the injection locked oscillator circuit. It also suggests that you should use this circuit with the crystal oven turned off."

In HSN #18, Graham Maynard provides a follow up to his original article.

"I don't know if my set is different from others, but mine locks ± 75 Hz and holds for hours. Maybe valve characteristics are a contributing factor, as I have made a number of substitutions – 6BZ6 for the 6DC6 RF amp and 6AH6 for the 6BA6 AGC IF amp. Recently I tried 100 K ohm resistors in the

R-390 and R-390A Receivers

2000

synchronous detector circuit for a friend's R-390A, but the phase lock was weak, only a few Hz. When I changed to 47 K ohm resistors, the lock was much better. This past weekend I added the synchronous detector circuit to yet another R-390A, this one with the 6BE6 BFO and product detector from *CQ*, January 1968. In this case 22 K ohm resistors worked best, and C2 was changed to a beehive trimmer to get the synch phase just right."

Dallas Lankford adds: "Thanks for the additional information on your remarkable circuit. My version of your circuit seems to work about the same as yours. A lock of ± 75 Hz is rather delicate when you consider that is only 15% of the distance between the 1 kHz marks on the BFO scale. But let me revise my estimate of stability upwards. After my R-390A has warmed up for an hour or so, lock is maintained for hours on stable signals. I have demonstrated your circuit to several visitors, and all have been impressed. Here are a few more things I have observed about the circuit. I think I now understand the noise reduction you mentioned previously. On strongly fading signals one hears phase distortion which sounds somewhat like noise. With the synchronous detector in use, phase noise is greatly reduced. On most daytime MW signals it seems that lock is generally found on the counter-clockwise side of zero beat. But for SW and nighttime MW signals, lock is found on either side of zero beat. This may be because daytime MW signals are generally linearly polarized, while SW and nighttime MW signals are elliptically polarized. Whatever the reason, lock seemed easier to adjust on SW and nighttime MW signals. After my initial excitement with the circuit diminished, I had removed my plug-in version and resumed tinkering with a phasing circuit that I am developing to generate cardioid patterns by mixing a loop and LW. At first I was somewhat disappointed with the resulting nulls. At night weak DX in the nulls of stronger signals sounded somewhat like badly fading SW signals, apparently caused by strong sub-audible heterodynes. Then it dawned on me that the synchronous detector circuit might help. It surely did! That evening I spent several enjoyable hours listening to R. Presnica in the null of WLS 890. Later I discovered that approximately the same improvement can sometimes be achieved without the synchronous detector (BFO off) by adjusting the RF gain control so that the meter reads 0, changing to MGC, and readjusting the RF gain control for best sound. But often switching the synchronous detector in again (BFO on) is better. Anyone who uses phasing units to generate nulls with two antennas should definitely try your synchronous detector circuit."

In HSN #19, Graham Maynard provides the latest version.

"Here is a new synchronous detector circuit which gives better sync and range. C2 and C3 are 65 pf variable trimmers, L1 is a 4.7 milliHenry subminiature choke, and the other components are as before."

Dallas adds: "Now that Graham has given us two synchronous detector circuits, lets call them GS1 and GS2. When a ham friend was unable to obtain any lock with GS1, a little detective work revealed the

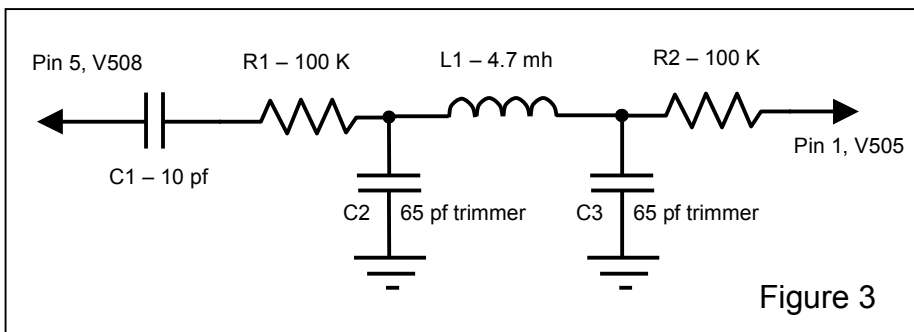

following. GS1 does not work at all in some R-390A's and the cause appears to be different internal parts in different BFO PTO brands. Motorola BFO PTO's work best with GS1, Electronic Assistance Corporation BFO PTO's are a close second, Stewart Warner BFO PTO's are O.K., but

Collins BFO PTO's don't work at all with GS1. I confirmed that the BFO PTO's are the crucial difference

R-390 and R-390A Receivers

2000

by switching a Motorola BFO PTO with each of the other BFO PTO's, but otherwise not changing the other IF subchassis. In each case the modified subchassis performed identical to an all-Motorola IF using GS1. To satisfy my curiosity, I removed the shield from each PTO and proved what I suspected – internal parts were different in each PTO. I suspect the culprit is L508, a 60 μ H, tapped, miniature encapsulated inductor. But I didn't try trading internal parts to verify my suspicion. Incidentally, the R-390A schematic for the BFO PTO is incorrect because it shows the BFO pitch varying L508. Actually, the BFO pitch is varied by moving a ferrite core in and out of L509, a 12 μ H coil about 0.5 inch diameter with about 25 turns of #31 enameled wire. Maybe GS2 will work with Collins BFO PTO's"

R-390A Meter Specifications

The R-390A line meter is 250 microamps full scale, 3360 ohms internal resistance. The R-390A carrier meter is 1 milliamp full scale, 17.7 ohms internal resistance. These parameters were measured using a DVM with 2% accuracy. You should not try to measure the internal resistances directly because your ohmmeter will almost certainly pin the meters, which may damage them. To determine the internal resistances, I measured the voltages across the meters at full scale, using a 9-volt battery in series with a 500 K ohm pot to adjust the meters to full scale. Then I measured the currents at full scale. The internal resistances were calculated using Ohm's Law. For example, one of my carrier meters measured 17.7 millivolts and 1.00 milliamps at full scale. Ohm's Law is $V = IR$, from which we get $0.0177 = 0.001R$, and solving for R gives $R = 17.7$ ohms. A carrier meter in one of my R-390A's, which gave readings 20 db below normal on strong signals, measured 19.2 ohms. So even a small error (high or low) in the internal resistance of a carrier meter will cause rather large errors in carrier meter readings. [Lankford, Issue #22, pg 2]

R-390A Sensitivity Testing Using The DA-121/U Dummy Load

The DA-121/U dummy load was used by the military to measure the sensitivity of an R-390A. It consists of a small RF tight metal enclosure with one BNC female connector at each end. A 100-ohm half-watt resistor is connected in series with the center conductors of the BNC connectors. A 68-ohm half-watt resistor is connected from one of the BNC center conductors to ground. The BNC connector with the 68 ohm resistor to ground is the signal input port (which is connected to a signal generator). The other BNC connector is the signal output port (which is connected to the R-390A). Dallas Lankford adds: "The DA-121/U dummy load appears to be an impedance matching device which matches 50 ohms to 125 ohms. I fabricated one and have used it to make precise sensitivity measurements on R-390A's. It works great. Included is a cut-away line drawing." [Hann, Issue #23, pgs 2,3]

Removing Spline Set Screws

One thing I noticed about my R-390A some months after its acquisition was that the PTO end points were so far out of alignment that I could not calibrate the KCS dial throughout the tuning range. I decided to take what I thought was the easy way out and order another PTO from Fair Radio. A few days after the arrival of the new PTO, I finally had an evening to spend on the replacement. But when I tried to loosen the spline set screw on the Oldham coupler, I found that someone had been there before me and stripped the splines. I tried everything - a larger spline wrench, hex wrenches, even super gluing a hex wrench to the screw. Nothing worked. Finally, a friend suggested I get a needle file, file a notch in the socket head, and remove it with a blade screwdriver. If you've never seen a needle file, they are similar to an aluminum nail file, but smaller and thicker. They are miniature files, and usually come in a set with various shapes and sizes. Once you see a set, you will recognize them as tools you needed, but didn't know

R-390 and R-390A Receivers

2000

you needed. Anyway, I filed and filed, and at last made enough of a notch that I could turn the screw with a blade screwdriver. When I got it out, I found that the threads were stripped at one point, which had caused the problem. I replaced it with a normal slot head screw, not having any spare spline screws. Removal of the old PTO and installation of the new PTO were routine with the help of Dallas instruction on PTO alignment in HSN 6. [Reda, Issue #23, pg 3]

R-390A AGC Mods

The R-390A maintenance manual TM 11-5820-358-35 goes into considerable detail about the AGC circuit (pages 32 - 34), and includes a simplified schematic as Figure 21 on page 35 of which a portion is shown here.

The AGC's of many R-390A's, including mine, have been modified using the so-called Cornelius AGC mod which was described in HSN 1 and 10. The mod consists of removing R545, replacing R546 by a 1N34A, 1N60, 1N270, 1N914, or 1N4158 diode with cathode connected to pin 1 of V509A, and replacing of R547 by a 10K-ohm half-watt resistor. The mod increases the AGC line voltage, which reduces the signal level at the diode detector V506B and, consequently, improves SSB reception quality.

Recently I discovered a modification which is easier to do and increases the AGC release times for FAST and MED. My mod does not require removing any components. You merely add two diodes as shown on the schematic above. I used 1N270 (actually ECG 109) diodes, but any of the diodes mentioned above could be used. Measured attack times for my mod are 0.001, 0.01, and 0.2 seconds, and release times are 0.01, 0.12, and 2.5 seconds for FAST, MED, and SLOW respectively. The times vary somewhat from one IF subchassis to another. The attack times are virtually the same as for the Cornelius mod. The FAST and MED release times are about twice as long as for the Cornelius mod, which is a modest improvement for SSB using the MED AGC position.

The attack and release times are not optimal for SSB; 0.002 seconds attack and 1 second release are often recommended. However, the MED position does provide acceptable SSB reception, and is a big improvement over an unmodified IF subchassis. [Lankford, Issue #23, pg 4]

Q-Multiplier and SB-620 for the R-390A

Connecting a Q-multiplier and SB-620 (Heathkit Scanalyzer) to an R-390A is not entirely trivial. Previously I had connected a Q-multiplier to the plate of the 1st IF tube. This worked, but seemed to produce a degraded signal. Apparently there was a detuning action between the Q-multiplier and the IF strip. Since the R-390A IF transformers are stagger tuned, I decided not to mess with them. The best approach is to use a 7-pin miniature tube test socket to obtain a solder lug at pin 1 of the 455 kHz third mixer V204. I used a full size test socket, so I removed the RF deck cover plate. [Many test sockets can be disassembled and modified to a shorter length so that the cover plate can be retained. Or you can remove the RF deck and add an appropriate connector beside V204.] After experimenting with different values of capacitance recommended in the Scanalyzer manual, I found that 7 pF gave the best overall results. I am currently using two Heathkit Q-multipliers, one as a notch, and one as a peak, together with the SB-620. I

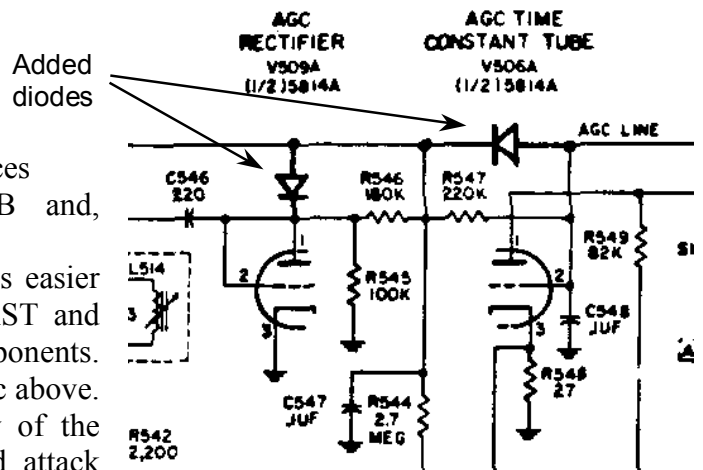

R-390 and R-390A Receivers

2000

find the combination useful in some difficult listening situations. The SB-620 helps adjust the null and peak. [Heinen, Issue #24/25, pg 2]

R-390A Space Diversity Reception

For those who may be interested in setting up two R-390A's for space diversity reception, here is the setup from TM-863. [Lankford, Issue 24/25, pg 2]

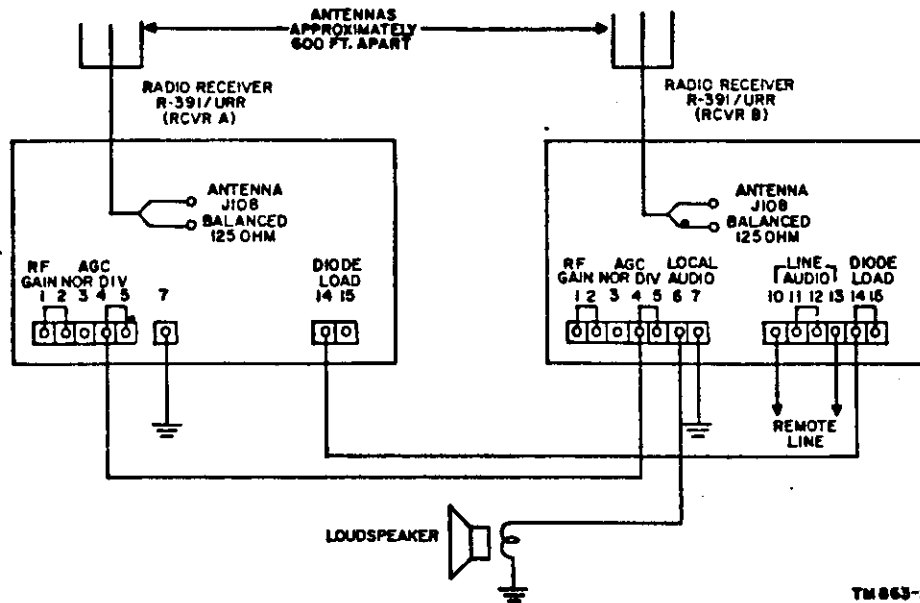

R-389, R-390, R-390A, R-391 Relay Problems

Some time ago, Richard Parker and I corresponded about problems he was having with the relays in his R-389 and R-391. In cooperation with professors in the Electrical Engineering Department at Louisiana Tech University, I assisted Richard with a solution. We had planned to write a detailed description of the problem and the fix, but due to space limitation in this final issue of HSN, [a premature death?? – Ed] and because the problem and cure apply the R-390 and R-390A as well, I have decided to write a generic description of the problem and the cure, and ask Richard to assist needy individuals with specific questions about the R-389 and R-391. His address is 21 Blue Grass Drive, Trenton, NJ 08638. Be sure to include an SASE if you write him.

The relays in R-3XX receivers are operated from a DC voltage generated by a copper oxide or metallic rectifier. My EE friends tell me that metallic rectifiers are notorious for slowly failing, which means that we all can expect problems with the relays in R-3XX receivers as time goes by. When the voltage of a failing rectifier drops, the relays may fail to operate in STAND BY and CAL, and the BREAK IN relays may fail to operate. The solution is to replace the rectifier (CR801 in an R-391, CR102 in an R-390A) with a full wave silicon bridge rectifier. At my suggestion, Richard used a 4 amp, 50 PIV bridge, Radio Shack # 276-1146. He also used a 25-ohm, 25-watt dropping resistor for his R-389 and R-391. The dropping resistor was used because a metallic rectifier puts out less voltage than a silicon bridge. I don't recall how Richard arrived at the 25-ohm value for the dropping resistor, and I don't know if the same value will work for an R-390A. The idea is to select the dropping resistor so that the DC voltage across the relay(s) is the same as before. Since this information does not appear to be in R-390A manuals, I suggest

R-390 and R-390A Receivers

2000

that you measure this value now and keep a record of it for future reference. Richard told me that the mod is easy to do in an R-389 and R-391 [Lankford and Parker, Issue #24/25, pgs 3,4]

Maynard ILO Mod Incompatibility

Upon modifying an IF subchassis and AGC switch according to the Chambers-Lankford SSB/AGC mod (Issue #27) which works extremely well, it was found that the strong SSB signal handling performance of the R-390A was severely degraded. Very noticeable audio distortion was noted on strong SSB signals, especially the 80m ham band, and as a result, I had to “ride” the RF gain control.

The solution was to add a switch (in my case mounted on a small L-shaped piece of aluminum, held down by the carrier meter pot adjustment nut) so that I could switch the ILO in and out. I might add that this mod is useful in any case because it permits the ILO to be switched in and out for alignment and calibration purposes. For example, with the ILO switched in, the BFO will lock to the crystal calibrator and you could be 300 Hz or more off frequency. Of course, the main purpose of the switch is to have available both Maynard’s ILO feature for AM synchronous detection, and the Chambers-Lankford mod for superb SSB performance. [Merrigan, Issue #27, pg 2]

Q-Multiplier for the R-390A

January 1965 *CQ* magazine, pages 37-38, suggests connecting a Q-multiplier as follows: inner conductor to pin 5 of V502 (the plate of the second IF amp) and shield to nearest ground. I tried this and found it to work well. If you use miniature coax, you can route the coax through the access hole in the top of the IF subchassis (the hole which passes the wires to the carrier meter zero adjust pot and IF gain adjust pot), so no drilling is required. [Merrigan, Issue #27, pg 2]

R-390A Thunderstorm Noise

One of the R-390As I worked on had a bad noise problem which sounded like a nearby thunderstorm was raging with no antenna connected. I traced it to the IF subchassis by disconnecting the output of the RF deck (P213 and P218) and by switching AF decks. Within the IF deck I used “Freeze-it” and found the culprit, an intermittent mica capacitor, after about 10 minutes work. I replaced the mica cap with an identical one from my “parts unit”, and all was well. Dallas Lankford adds – “This is a wonderful discovery which Shaun has made. I had an intermittent “thunderstorm” problem in an IF deck which I never was able to isolate. For a while I suspected a bad tube, but repeated efforts to isolate the bad tube failed. It never occurred to me that I might have a bad or intermittent mica capacitor. Now I know what to do if I ever encounter the problem again. However, let me add that some of these “thunderstorm” problems are bad tubes, so you should check for bad tubes first before you proceed to try to isolate a bad or intermittent mica cap.” [Merrigan, Issue #27, pg 2]

R-390A Won’t Turn Off?

When you turn your R-390A FUNCTION switch to the OFF position, do your dial lights remain on? If so, then you have a worn microswitch (which is part of the S102 function switch assembly). The only permanent cure is to drop the front panel, unsolder the two wires to the microswitch, remove the microswitch, gently pry the side plate off the microswitch (held on by 4 small screw-like, but unthreaded and unslotted, pieces of metal), and refinish the microswitch contacts. This is akin to refinishing the points of an automobile. GC makes a burnishing tool which can be used, or you may use different grits of wet-dry sandpaper, starting with #400, then #600, then finer grits (which you can make by sanding a piece of metal with #600 until it is “well used”). The idea is to make the contact surfaces of the switch flat and smooth

R-390 and R-390A Receivers

2000

again. After years of use, repeated arcing has roughed up the surfaces so much that finally one arc causes the surfaces to literally weld together. An 8X loupe is probably essential for inspection of your work. [Merrigan and Lankford, Issue #27, pg 2]

Chambers-Lankford R-390A AGC and BFO Mods

Preface

This AGC/BFO mod is not perfect. The SLOW attack time is 6 mS, which causes some distortion, pops, and clicks on the initial syllables of SSB transmissions. These are not eliminated even with a product detector. Some additional distortion is contributed by the BFO mod, which is not a product detector. But it is a relatively simple mod, and gives excellent results for the amount of effort involved. For CW it is outstanding. In any case, it is better by far than any other SSB mod which has been done before. Wally and I have some ideas about how to speed up the slow attack, and I have an excellent product detector waiting in the wings, so we hope to eventually arrive at the outstanding SSB performance which the R-390A is capable of. Those of you with an EAC IF deck, be sure to see the note at the end of the article. (Wally Chambers & Dallas Lankford)

Two things prevent an R-390A from performing well on SSB and CW signals - unsuitable attack and release times for SSB and CW, and low BFO amplitude at the diode detector.

The usual way to demodulate SSB or CW is with a product detector. There are two ways to add a product detector to an R-390A. The BFO circuit can be converted to a product detector as described by Capt. Paul Lee in his 1968 CQ article, "Modifying the R-390A receiver for SSB," pages 55-58; see also a variation using relay switching which includes the R-390A noise limiter function with the product detector as described by Eugene Hubbell in his 1974 Ham Radio article, "Improving the R-390A product detector," pages 12-15. Or an external product detector can be connected to the R-390A 455 KHz IF output, such as one of the military sideband converters, a Hammarlund HC-10 converter, or a home built product detector like the one described by Alan Nusbaum in his November 1985 Ham Radio article, "External product detector improves receiver performance," pages 107-111.

However, there are disadvantages to these approaches. Lee's product detector requires that an R-390A mainframe be rewired, which means that you cannot use that mainframe without a specially modified IF subchassis. In addition, the noise limiter is bypassed, and Hubbell reported that there was a regenerative effect which occurred at the BFO frequency, resulting in a peak in the audio response. Hubbell implemented Lee's mod with a relay, which eliminated the regenerative effect. He also expanded Lee's mod by making the noise limiter operational with the product detector. But Hubbell's mod requires a special Potter and Brumfield relay (type PW5LS, 2 mA, 10K ohm coil) which now costs about \$100 retail, and the relay must be mounted in a 7 pin miniature rocket added to the IF subchassis. Hubbell's approach can be implemented with an ordinary low voltage relay, but then you will have to provide additional low voltage, high current, DC for the relay coil, and use a BJT to switch the relay on and off with the switched 200 volt B+ line. There is hardly enough space to mount the necessary additional components. The military SSB converters are almost always large and heavy, and generally use many tubes (CV-157: 44 tubes, 125 lbs.; CV-1982: 23 tubes, mostly nuvistor, 30 lbs.). I have been told that there is a small solid state SSB converter made by McGee Industries, but I have never seen one. The Hammarlund HC-10 converter (only 10 tubes) requires precise frequency alignment for whichever sideband you want to use, or a wider than necessary R-390A bandwidth if you want to switch sidebands quickly. If you use a wider than necessary R-390A bandwidth, then adjacent QRM activates the R-390A AGC and degrades the

R-390 and R-390A Receivers

2000

performance of the HC-10. Finally, none of these product detector mods or add-ons does anything about the unsuitable R-390A attack times and release times for SSB and CW.

For SSB an attack time of 2 milliseconds (mS) is often stated as optimal, while release times of 500 mS for fast SSB release and 2 seconds (S) for slow SSB release are considered suitable. My goal was to modify the R-390A AGC in such a way that attack times for all three AGC speeds (FAST, MED, and SLOW) were about 2 mS, and the MED and SLOW release times were about 780 mS and 2 S respectively.

My starting point was Cornelius' AGC mod, which speeded up attack times for FAST and MED. The original Cornelius AGC mod removed R545, replaced R546 with a back pointing diode, and replaced R547 with a 10K-ohm resistor. I developed a better variant of Cornelius' AGC mod by leaving R545, R546, and R547 unchanged, and adding two back pointing diodes, one across R546, the other across R547.

To improve the SLOW attack time, it was necessary to redesign the SLOW AGC circuit. In the SLOW AGC position, C551 is connected across the plate and grid of V506A. By unsoldering the wire at pin 1 of V506A (which connects lug 8 of S107 and pin 1 of V506A) and resoldering it to a convenient nearby ground lug (pin 8 of V506), the SLOW attack time problem was mostly solved. But with this change the SLOW and MED attack and release times are identical. So a new capacitor C1 was inserted from lug 9 of S107 to ground (after removing the original ground connection). Now in the MED position C1 is in series with C551, which permits the MED release time to be adjusted to a smaller value than the SLOW release time.

I don't like modifying an R-390A mainframe as a matter of general principle. However, the addition of C1 does not prevent using an unmodified IF subchassis. The MED release time with an unmodified IF subchassis will not be as slow as with an unmodified mainframe, but that is hardly noticeable.

At this point in my experiments the SLOW release time was about 500 mS, but a slow release time of 2 S was desired. I tried adding additional capacitance in parallel with C551, but that caused a slower SLOW attack time (and the SLOW attack time was already too slow at about 10 mS). To make the SLOW release time slower without increasing the SLOW attack time, R547 was removed (leaving only the back pointing diode in place of R547). I learned the hard way that this diode must have a very high back resistance and that 1N34A and 1N270 germanium diodes are not suitable. A 1N4148 or 1N914 is suitable because they have a reverse leakage current rating of 0.025 microamps at the maximum rated voltage of 75 volts, which works out to a back resistance of about 3000M ohms. Thus, the AGC capacitors are forced to discharge through the 1.77M ohm combined resistance of R201 and R234 (a voltage divider for the 6DC6 RF amplifier grid AGC voltage).

After R547 was removed the SLOW release time was too slow, about 3.7 S. To adjust the SLOW release time to about 2 S, C551 was replaced with C2. My final AGC mod is shown on the following simplified schematic. I used a scope to measure the release times, and confirmed that the release times can be calculated from the conventional $T = R \cdot C$ time constant formula (when R is in megohms and C is in μF , T is in seconds). So it is easy to select the values of C1, C2, and even C548 for whatever release times you desire. The time constant formulas are as follows:

$$T_{\text{FAST}} = 1.77 \cdot C548, \quad T_{\text{MED}} = 1.77 \cdot \left(C548 + \frac{C1 \cdot C2}{C1 + C2} \right), \quad T_{\text{SLOW}} = 1.77 \cdot (C548 + C2)$$

For unchanged C548 (= 0.1 μF), C1 = 0.47 μF , and C2 = 1.22 μF , the measured and computed release times were about 180 mS, 780 mS, and 2.3 S for FAST, MED, and SLOW respectively.

Replacing C551 by the smaller capacitance (1.22 μF) had the beneficial effect of speeding up the SLOW attack time to about 6 mS. The MED and FAST attack times were about 3 mS and 1 mS

R-390 and R-390A Receivers

2000

respectively. The SLOW attack time is not quite as fast as I wanted, but it is the best that can be done without more substantial modifications.

Like the Cornelius mod, my AGC mod increases AGC line voltage, which causes higher carrier level meter readings and reduces the signal levels at the diode detector, thus reducing audio output. The reduced audio output is not a problem because an R-390A has plenty of reserve audio gain. The increased carrier level meter readings should not be a problem for most R-390As. But if the meter pins on strong signals, there are two cures. Unsolder one of the meter leads and add one-ohm resistors one at a time until the meter no longer pins on strong signals. The carrier level meter has a very low internal resistance, about 17.4 ohms nominal, so a small additional resistance will cause a large change in meter readings. The other cure is to replace R524 (680 ohms nominal) by a larger resistor. The best solution here is to add a 500-ohm, 2 watt, ten turn, wire wound resistor in series with R524. In effect, this adds a meter sensitivity adjustment. The reduced signal levels at the diode detector has the beneficial effect of reducing distortion on SSB and CW.

The improvement in SSB quality caused by reduced signal levels at the diode detector, the difficulty of converting an R-390A BFO circuit to a product detector, and the defects of add-on converters motivated me to examine the possibility of further improving the diode detector for SSB and CW. In his May 1956 QST article, "Reception with product detectors," Murray Crosby, W2CSY remarked that proper reception of SSB may be obtained with a diode detector provided the signal amplitude entering the diode detector is less than or equal to the BFO amplitude.

I added a 47 pF 500 volt mica capacitor in parallel with the 12 pF BFO injection capacitor C535, and was pleased that most of the residual SSB distortion was eliminated. But when I measured the signal and BFO amplitudes I was surprised that a 50 dB unmodulated RF signal produced a 4 volt peak signal at the diode detector, and that the BFO was already 12 volts peak with the 12 pF injection capacitor alone.

Wally Chambers, K50P provided the answer to this perplexing situation. In the 49th (1972) and 54th (1977) editions of *The Radio Amateur's Handbook*, page 239, it is said that the BFO signal amplitude should be 5 to 20 times greater than the strongest SSB or CW signal at a diode detector if distortion is to be minimized. The addition of a 47 pF capacitor across C535 increased the BFO amplitude at the diode detector to about 25 volts peak, which makes the BFO amplitude about 6 times greater than a 50 dB unmodulated RF signal. There is apparently some room for additional improvement. Wally suggested that replacing R530, the 22K ohm BFO plate resistor, with a 12 mH choke might further increase the BFO output, but I have not tried that. The 22K ohm BFO plate resistor is a large 1 watt resistor which is difficult to remove, and there is not much space underneath or beside the BFO bellows coupler for a 12 mH choke.

For Capacitors C1 and C2 I used 250 volt mylar, radial leads. For a 1.22 μ F capacitor I used a 1 μ F capacitor and a 0.22 μ F capacitor in parallel. I used 1N4148 diodes from a Radio Shack package marked 1N914.

To add C1 you will need to remove the R-390A front panel. Unsolder and remove the end of the insulated stranded wire, nominally white insulation, at pin 9 of S107. Clip one or more loops of cable lacing which secure the white wire to determine if the other end is connected to lug 1 of the LIMITER potentiometer R120. If so, the white wire may be removed completely. Tie the loose end(s) of the cable lacing. If desired or necessary, use new cable lacing to tie new loops where the old loops were removed. If the white wire does not terminate at pin 1 of R120, or if you do not want to remove the white wire, you can add a small insulated 4-40 standoff to the top screw of S107. If there are not enough screw threads to mount the insulated standoff securely, you will have to remove the nut and/or lock washer. And if the nut and screw threads are painted with varnish, you may have to remove S107 from the front panel to access

R-390 and R-390A Receivers

2000

the screw bead. A hot soldering iron tip can be used to soften the varnish so that the nut can be removed without stripping the screw head or rounding off the nut (they are small and nominally brass).

R546 is usually connected to pin 1 or 2 of socket XV509 and to an insulated standoff. It is easy to add a diode across R546. The cathode lead of the diode can go to either pin 1 or pin 2 of XV509, and the anode lead of the diode goes to the insulated standoff.

R547 is usually connected to pin 2 of socket XV506 and to an insulated standoff. How easy it is to remove R547 depends on the order in which the other wires are mounted on the insulated standoff. You may have to temporarily remove other wires to access the R547 lead. Be careful uncrimping the lead of R547 at pin 2 of XV506. It is easy to break a tube socket lug. The cathode lead of the diode goes to the insulated standoff, the anode lead to pin 2 of XV506.

C551 is not removed from the IF subchassis, and one lug of C551 is used as a tie point. Remove C548. One end is usually connected to a ground lug beside XV509, the other end to one of the C551 lugs. Save C548 in case you want to undo my mod. Unsolder and remove the end of the insulated stranded wire, nominally white with blue and black tracers, attached to the same lug of C551 to which C548 was attached. Take a 4.5-inch length of insulated, stranded, tinned, #22 wire, strip 0.5 inch of insulation from one end, strip 1 inch of insulation from the other end, remove the solder from the lug of C551 to which C548 was not attached (this lug of C551 should have attached to it an insulated stranded wire which is nominally

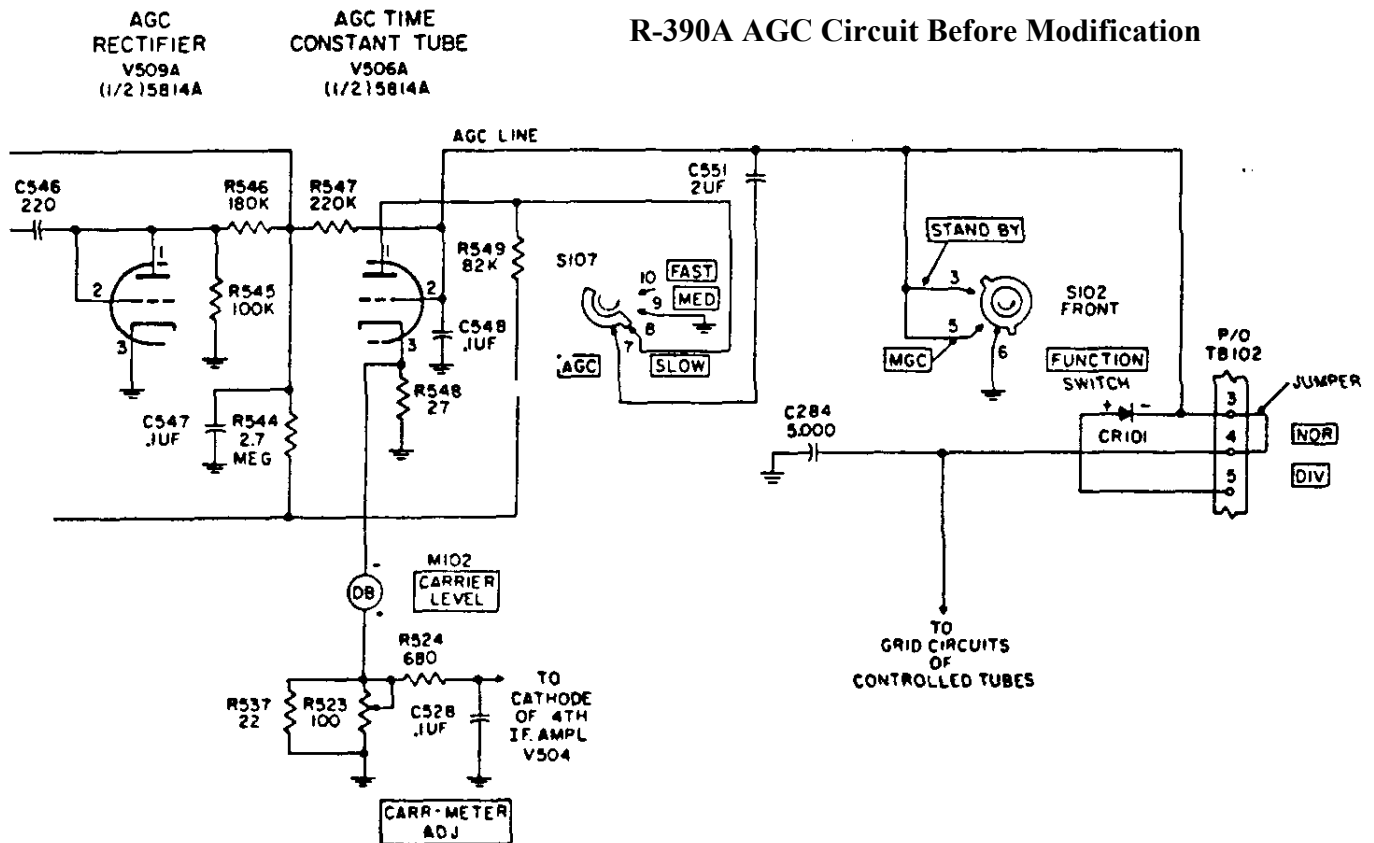

white with blue and red tracers), run the short stripped end of the stranded wire through this lug of C551, crimp it, and solder it. On the metal panel beside C551 there are two Phillips head screws which mount ground lugs in adjacent compartments. Remove the screws and reverse them. Mount two small insulated 4-40 standoffs on the screw ends. If there are not enough threads to securely mount the insulated standoffs,

R-390 and R-390A Receivers

2000

you will have to use longer screws. Mount C2 on the two insulated standoffs, attach the free end of the wire removed from C551 (white with blue and black tracers) to one standoff, add a 0.1 μ F, 250 volt, mylar capacitor running from that same standoff to the ground lug from which C548 was removed (this 0.1 μ F capacitor replaces C548), attach the free end of the new stranded wire added to the other lug of C551 to the other insulated standoff, and resolder or solder all remaining added or changed lugs.

To add a 47 pF capacitor across C535 you must remove the BFO PTO bellows coupler. The spline set screws in the bellows coupler are painted with varnish. To remove them without stripping the splines, use a 45 watt 900 degree soldering iron to soften the varnish. Apply the hot iron tip directly to a setscrew for about 30 seconds, and then apply reasonable pressure with a spline wrench. If the setscrew does not release with reasonable pressure, apply the hot iron tip again for about 30 seconds.

You may wonder why Collins did not design the R-390A AGC this way and save us all the trouble of modifying the AGC for fast attack and slow release. And why did they use the Miller effect circuit for the SLOW AGC circuit? After all, the Miller effect SLOW release circuit in an R-390A has the disadvantage of being slow (200 mS) attack. I learned what I believe is the answer quite by accident: reliable SLOW release.

As I was developing my AGC mod, I discovered to my amazement that the SLOW release time got faster as the R-390A warmed up. I first noticed this effect by observing the carrier level meter. Did I imagine it? No. Scope measurements confirmed that the SLOW release time gradually decreased from about 2 S shortly after turn on from a cold start to about 500 milliseconds after 30 minutes. The cause was traced to a gassy 1st IF amplifier tube. It appears that Collins used the Miller effect SLOW AGC circuit because it is not effected significantly by gassy AGC controlled tubes.

That's the bad news. The good news is that it is relatively easy to determine if a gassy tube is degrading the SLOW release. Merely observe the carrier meter descent rate when you tune quickly away from a calibrator marker shortly after you turn on the R-390A from a cold start, and then observe the descent rate about 30 minutes later. If the descent rate is noticeably faster, then one or more gassy tubes may be the cause. The most likely candidates are the 1st, 2nd, and 3rd IF amplifier tubes. One of these three tubes was gassy in two out of three IF subchassis I have modified. Naturally, these bad tubes tested good on a tube tester. The RF amplifier and three mixer tubes are also candidates, as well as the 4th IF amplifier, AGC amplifier, and perhaps the AGC time constant tubes.

After Modification

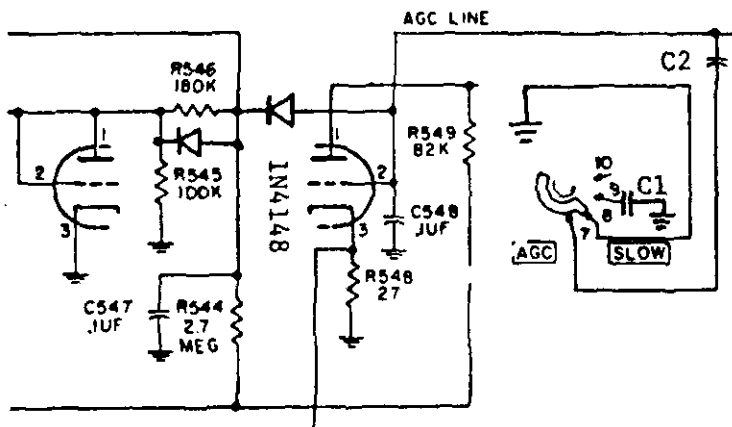

I was concerned that my AGC mod should not degrade the excellent AM performance of an unmodified R-390A. It does not. In two modified IF subchassis I included a 330K ohm resistor in series with the diode which replaced R547 and a switch across the resistor. In effect, this provided switched attack times, slow attack for AM and fast attack for SSB and CW. After (considerable listening I have concluded that there is little benefit to switched attack times. A few listeners, like me, may hear a small amount of very low frequency (below 50 Hz) audio distortion on AM signals using the FAST AGC speed with fast attack with the 455 KHz IF output feeding an AM

R-390 and R-390A Receivers

2000

synchronous detector followed by a hi fi amplifier. But most listeners will not notice any difference between fast and slow attack. If you have no interest in SSB or CW, there is hardly any reason for you to do my mod because it does not improve AM performance. Of course, with the original R-390A AGC it is annoying that the carrier meter pins for several seconds when switching between SLOW and MED. That does not happen with my mod.

I would like to express my appreciation to Wally Chambers, K50P for sharing his experiences modifying R-390A AGC's, and for discussing many of the ideas in these mods.

NOTE: In some IFs, especially EAC's, it will be virtually impossible to do this mod because of wiring layout. In that case, leave C551 as is and insert a 2 mF or 2.2 mF, 250 volt mylar capacitor between pin 8 of S107 and ground (instead of grounding pin 8). The attack and release times are almost exactly as with the more complex mod. [*Lankford, Issue #27, pgs 2-8*]

Chambers/Lankford AGC Mod on the R-390 – Some Feedback

I preface these observations on audio quality only as I do not have the necessary equipment to measure the attack and release times. As the AGC circuits appear to be almost identical between a 390 and a 390A, I thought I would give it a try. Basically, it works very well on slow but is worse on medium and fast. Using the R-390 schematic #'s: put a diode across R-556, replaced R-557 with a diode and put 47 pf cap across C-536. I then disconnected the parallel combination of C-547 and C-546 and put a .22 mfd in parallel with one of them to get the desired 1.22 mfd. At that point, I reinstalled the IF chassis to see how it worked and discovered that the slow seemed excellent with no distortion on even the strongest of SSB signals. I then proceeded to change the AGC switch as per the 390A mod. Unfortunately that introduced noticeable distortion on the slow with the med and fast even worse. So... I changed the switch back to original and just accepted the excellent slow for SSB. However, before changing back I temporarily removed R-555 (100K) as per the earlier Cornelius mod. Result: I could not tell the difference with my ears either way with respect to that resistor. In the end, I put the switch back to original and left R-555 disconnected at one end. Finally, I put the IF gain pot about half way between the stops. I am highly pleased with the performance on slow and would highly recommend this minor change to make SSB sound great without riding the RF gain all the time. There is one anomaly that I discovered. R-554 coming off Z-503 is schematically 2.2K. In four IF decks, the installed value was 470 ohms (and looked original). I temporarily removed this resistor and used a substitution box to experiment. It seemed that the 470 sounded much better than the 2.2K or any other value for that matter. [*Metz, Issue #36, pg 5*]

R-390A AGC Problem and Fix

An R-390A of mine would work nicely for about 10 minutes from a cold start, then the receiver would exhibit distortion and blocking, which worsened as the unit heated up. A check of the AGC voltage on the rear panel revealed lower than normal AGC voltage (typically -4 to -7 VDC compared to "good" AGC voltage of -8 to -15). I went to work on the IF subchassis by measuring the resistance between pin 6 of J512 and ground, measuring 1.5 Meg (it should have read infinity). I suspected a leaky capacitor, but all candidates were OK. After isolating all of the AGC tie-ins on the IF deck, the mechanical filter assembly was identified as the culprit. However, its bypass capacitor (C512) was OK. The only remaining possibility was one of the mechanical filters (AGC voltage is applied to V502 through the coils of all mechanical filters). To find the bad mechanical filter, I had to unsolder all leads on both terminals (of each mechanical at the "AGC end" of the mechanical filters. The resistance between either terminal -and the filter case should be infinity. For the 8 KHz filter, the "cold" resistance was 1.5 Meg, and when heated to

R-390 and R-390A Receivers

2000

145 degrees with a hair dryer, the resistance was 300 K ohms. The 8 KHz filter sounded fine in use with the RF gain control reduced to eliminate overload. I hope this saves someone a lot of time. [Tatum, Issue #28, pg 2]

R-390A Alignment

Before aligning R-390A tuned circuits, alignment of the Veeder Root counter, cams, RF bandswitch gears, antenna trimmer, and PTO should be inspected, and, if necessary, realigned.

To determine if the Veeder Root counter (the MCS/KCS counter; see Fig. 1) is aligned (1) turn the

loosen spline set screws on non-mar clamps of BFO and BANDWIDTH shafts and push shafts through front panel

loosen DIAL LOCK mechanism nut (behind knob) and rotate mechanism to clear metal disc (behind front panel)

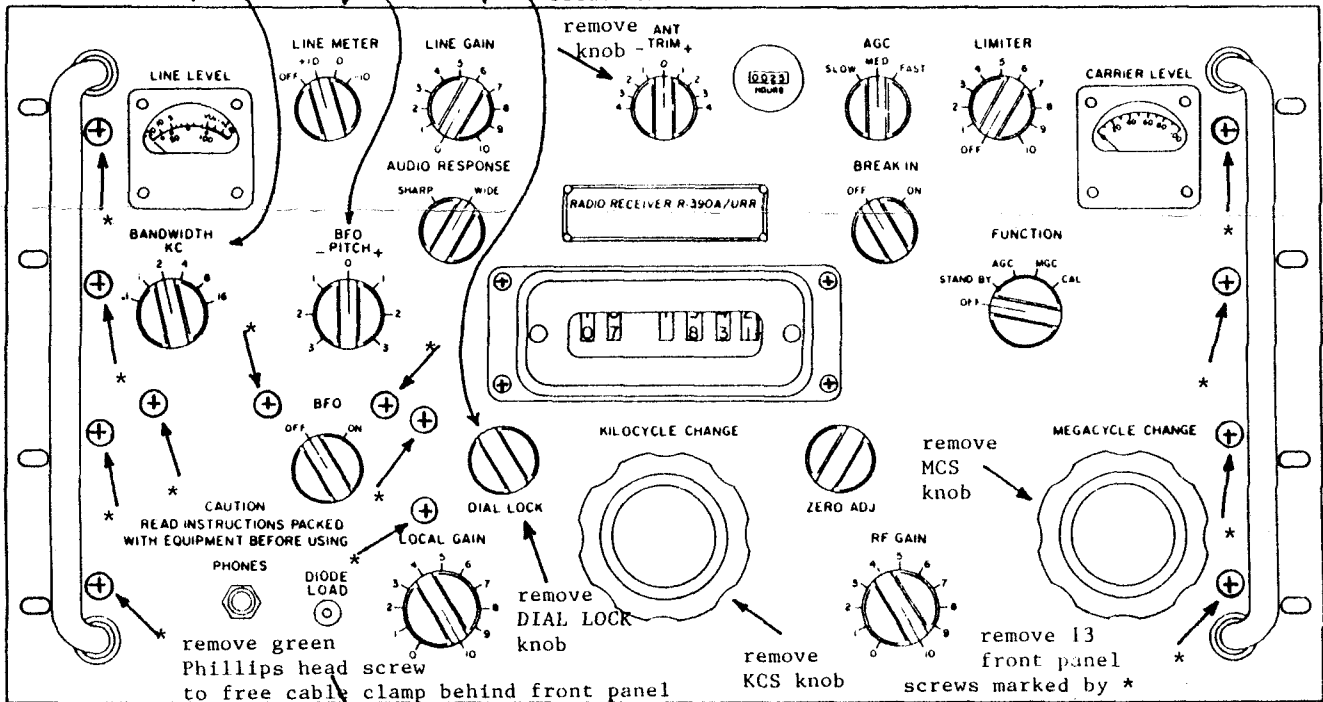

FIG. 1 Front Panel Removal

ZERO ADJ knob clockwise until the clutch is disengaged, i.e., until the digit wheel of the Veeder Root counter does not move when the KCS knob is turned through its zero adjust range (about 14 KHz), (2) set the KCS knob at about the center of its zero adjust range, and (3) turn the ZERO ADJ knob fully counter clockwise to engage the clutch. The KCS knob should be left in the center of its zero adjust range for the remaining checks and alignments. Next, (4) turn the KCS knob throughout its entire range, from one limit of the 10 turn stop to the other. An aligned Veeder Root counter should read about xx-965 and xx+035 at the stop limits. In other words, the 1000 KHz tuning range of an R-390A has about 70-KHz of over-range, and the over range should be divided equally between the two ends of the 1000 KHz tuning range.

When an R-390A is tuned to 07+000 the cam tips should align with the lines on the front plate of the RF subchassis as shown in Fig. 2. The RF bandswitch gears should also align as shown in Fig. 2.

If the Veeder Root counter reads within 3 or 4 KHz of xx-965 and xx+035 at the stops, and the cams align within 3 or 4 KHz of 07+000, then they need not be realigned. But if they are off more than 3 or 4 KHz, then you should consider realigning them.

R-390 and R-390A Receivers

2000

The Veeder Root counter and cams alignments are interrelated. Changing the alignment of the Veeder Root counter changes the alignment of the cams, and vice versa. Also, each cam can be aligned independently of the other cams by loosening the non-mar clamp on the gear in front of the cam.

Because the Veeder Root counter and cams alignments are both dependent and independent, there are many ways they could have gotten out of alignment, and thus it is difficult to specify all ways to realign them. Nevertheless, here is a generic realignment of the counter and cams which should work in most cases.

If all of the cam tips align at the same frequency, and the difference between the cam tips alignment and 07+ stop is about 35 KHz (example: cam tips align at 07+015 and 07+ stop is at 07+050), then loosen

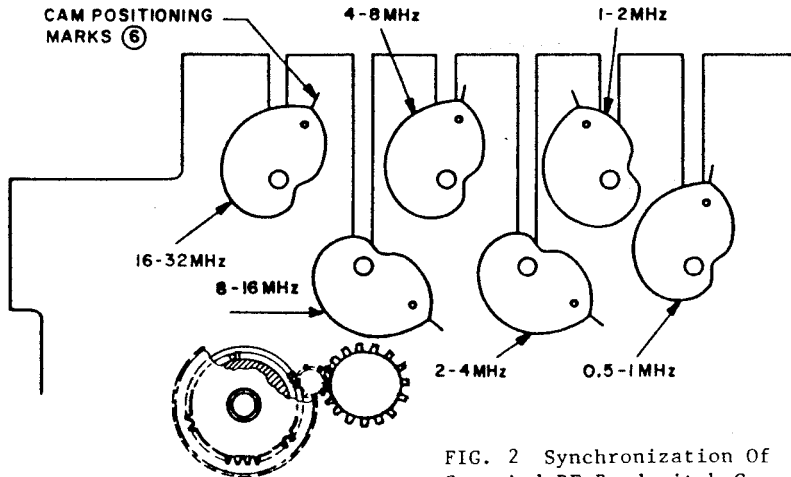

FIG. 2 Synchronization Of Cams And RF Bandswitch Gears, Frequency Set At 7+000

the non-mar clamp on the right side bevel gear of the Veeder Root counter and reset the digit drum of the counter to read 07+035 with the KCS knob at the 07+ stop. The bevel gear can be accessed by removing the counter cover plate which is attached to the front panel by 4 Phillips head screws; see Fig. 1. After tightening the non-mar clamp on the bevel gear, turn the KCS knob through its range to make sure that the bevel gear is not binding and that there is no backlash in the digit drum. If there is binding or backlash, loosen the non-mar clamp, reposition the bevel gear, tighten the

clamp, and check for binding or backlash again. Repeat until binding and backlash are eliminated or minimized.

If all of the cam tips do not align at the same frequency, remove the front panel (see Fig. 1), set the KCS knob to the 07+ stop, align the Veeder Root counter to 07+035, set the KCS knob to 07+000, and for each cam loosen the non-mar clamp on the gear in front of the cam, set the cam tip to its alignment line, and tighten the non-mar clamp. It may be necessary to remove the associated rack tension springs when aligning a cam tip.

If all of the cam tips align at the same frequency, but the frequency difference between cam tip alignment and 07+ stop is not 35 KHz, then you can either realign the counter and cams as described above, or pull the gear on the KCS shaft and reposition it so that the frequency difference is 35 KHz (be sure to observe the amount of tension on the split gear before removing it, and reinstall it with the same amount of tension).

The RF bandswitch alignment is also shown in Fig. 2. The 4 teeth on the large gear should point straight down (they can be seen from underneath). The only sure way to determine if an RF bandswitch is out of synchronization and to realign an unsynchronized RF bandswitch is to use a known good RF subchassis for comparison. Both RF subchassis should be removed from their respective R-390A's so that the positions of the bandswitch wafers can be compared as the MCS shaft is turned through its entire range.

Synchronization of the crystal oscillator (attached to the RF subchassis) also requires a known good RF subchassis for comparison. It is unlikely that either the RF bandswitch or crystal oscillator will be unsynchronized, and so I have not given many details about how to realign them. In both cases an obvious

R-390 and R-390A Receivers

2000

clamp is loosened, the shaft repositioned, and the clamp tightened. And in both cases several attempts may be needed to get it right.

Alignment of the ANT TRIM is shown in Fig. 3. Two setscrews behind the gear drive are loosened to realign the antenna trimmer. Often the red paint of the "red dot" has flaked off, and there is only a small dimple (like a center punch mark) where it was. Do not tighten the setscrews too tight, otherwise the Bakelite insulation between the gear drive and antenna trimmer shaft may be crushed, which may cause the AGC line to be shorted to ground through R201.

If the PTO end points are aligned (tuning from xx+000 to xx+000 changes the received frequency by exactly 1000 KHz), then the PTO can be synchronized by adjusting the Oldham coupler; see Fig. 4. Before synchronizing the PTO, check the BFO and CAL alignments as follows. Set the BANDWIDTH to 2, FUNCTION to CAL, and tune any calibrator signal so that it is in the center of the filter passband. (For example, suppose that as you tune below the calibrator signal near xx 500, the carrier level meter falls by 10 dB at xx 498.6, and as you tune above it falls by 10 dB at xx 501.2, then the filter center is about $(498.6 + 501.2) / 2 = xx 499.4$.) Turn the BFO on, loosen the BFO

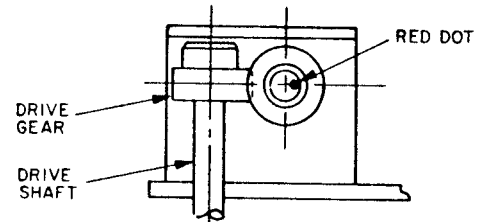

POSITION **ANT TRIM** KNOB AT 0 WITH RED DOT AS SHOWN

FIG. 3 Synchronization Of ANT TRIM

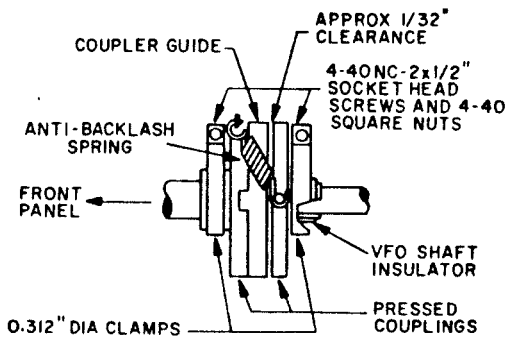

FIG. 4 Oldham Coupler Clearance And Details

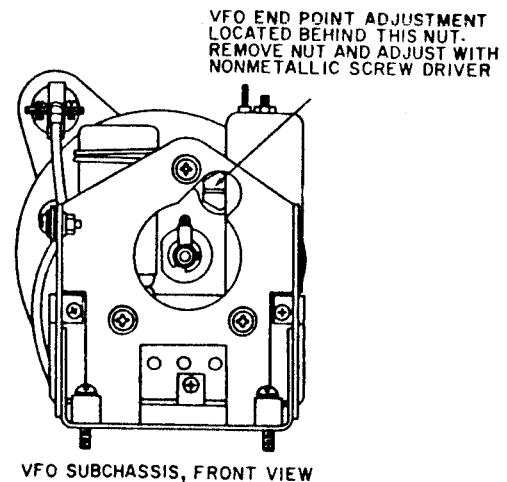

FIG. 5 PTO End Point Adjustment

tuning shaft clamp, and rotate the BFO PTO shaft for zero beat while holding the BFO knob at 0 (12 o'clock). Tighten the BFO shaft clamp. Next, set BANDWIDTH to 16, change the FUNCTION switch to AGC, and zero beat to WWV (5, 10, or 15 MHz, whichever is stronger). Change the FUNCTION switch back to CAL and zero beat by turning the CAL ADJ slot adjustment on the rear panel. If the calibrator will not zero beat, you probably have a defective 200 KHz calibrator crystal (which should be replaced). Set the Veeder Root counter to xx 000. (For example, let's say you were tuned to WWV 15, and the counter read 15 003.8. Then you would set the counter to 15 000 and hear a 3.8 KHz het with the BFO.) Loosen the clamp on the front panel side of the Oldham coupler, and turn the Oldham coupler for zero beat while holding the KCS knob to keep the frequency indication at xx 000. Tighten the clamp.

PTO end point alignment for non-Cosmos PTO's has been described in detail in HSN # 6. For Cosmos PTO'S, end point alignment is the same, except that the end point adjustment access hole is

R-390 and R-390A Receivers

2000

the balanced antenna input through a UG-971/U twinax to C connector adapter and a UG-636A/U C to BNC connector adapter. But if you don't have a signal generator, or you are in a rush, you can use the CAL approach for them too. If you align an R-390A which has not been aligned in many years, some of the ceramic trimmers may be nearly "frozen." Firm screwdriver torque will usually break them free with an audible "snap." However, if loss of signal level is observed after breaking the trimmer free, you should remove the coil (remove the rack and slugs for that coil set to access the # 4 Phillips head screw at the bottom of the Bakelite coil form, and unplug the coil assembly), remove the coil assembly shield, and inspect the underside of the ceramic trimmer assembly to see if the metal base has rotated during unfreezing and shorted to one of the metal coil supports.

After the RF subchassis has been aligned, each of the ceramic crystal oscillator trimmers should be peaked. Tune to any CAL-signal-in the band indicated above the trimmer (see Fig. 7) and peak the signal. Not shown in Fig. 7, eight of the trimmers can be peaked in either of two bands: 0-17, 1-18, 2-19, 3-20, 4-21, 5-22, 6-23, 7-24. After peaking such a trimmer in one band, you do not need to peak it again in the other band. Peak T401 (also marked T207).

Alignment of the IF subchassis is usually unnecessary. But if you insist on aligning it, get yourself a set of TV Alignment Tools from Radio Shack, catalog no. 64-2223. The white hex alignment tool may be used to peak the AGC IF transformer Z503. Do not meddle with the IF transformers T501 - T503. They are stagger tuned, and their peaks are very broad. Even if they are somewhat out of alignment, it will not matter. The red alignment tool with metal tip is suitable for aligning trimmers (provided the metal shaft is insulated to avoid shorting RF trimmers; see above). The mechanical filter trimmers may be accessed by removing the shield on top of the chassis, and disconnecting the shafts to the front panel knobs, releasing the green quick release screws, and tilting the IF subchassis up far enough to access the trimmer holes in the side of the chassis. I'll let you discover for yourself which trimmer peaks which filter. Don't mess with the crystal filter inductor L503 or trimmer C520 unless you have to replace the 455 KHz crystal, and then consult the manual for alignment. The IF gain may be adjusted by R519, a slot adjust pot with lock nut. The manual provides detailed instructions for setting the pot. My approach is to set the IF gain for minimum, i.e., the slot adjust is rotated fully clockwise. However, in one R-390A the IF gain adjust pot was marked 10K (correct), but measured 20K (incorrect) at minimum gain (maximum resistance). So I always measure the resistance of the IF gain adjust pot to be sure it is about 10K when the slot adjust is fully clockwise. Some of these 10K pots measure a bit less, say 8.5K, which is OK. Just don't go over 10K. The carrier meter zero adjust R523 is the only flakey feature on an R-390A. It is virtually impossible to zero a carrier meter with R523, and even if you do succeed in zeroing a meter (with no signal), the meter will not hold zero (because the pot wiper setting is so critical). There is only one solution to this problem. Replace R523 with a 10-turn pot, Clarostat 73JA 100 ohm 2 watt wire wound. Instead of reusing the

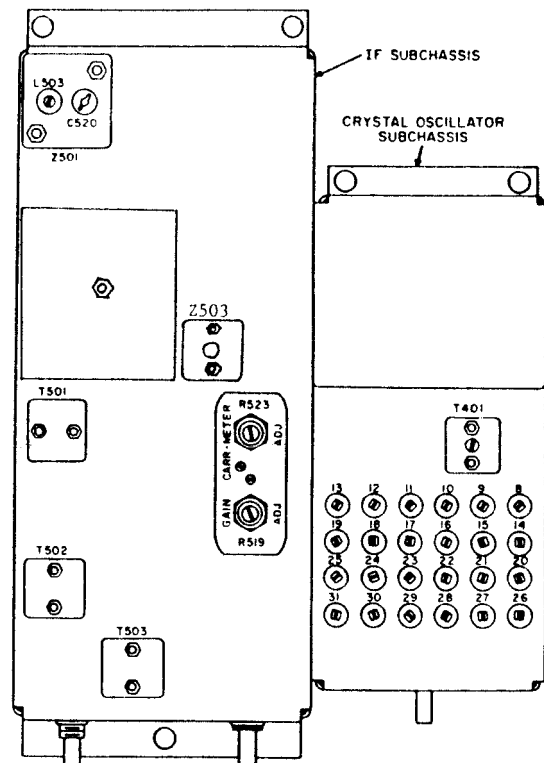

Figure 7 Xtal-Osc and IF Alignment

Figure 7 Xtal-Osc and IF Alignment

R-390 and R-390A Receivers

2000

original 22 ohm 1 watt R537 which shunts the original R523, or trying to locate another 22 ohm 1 watt resistor (with leads which are too large to use effectively with a 73JA), get a 10 ohm 1 watt resistor at Radio Shack, catalog #272-151 (it has smaller leads), and use it. After doing this mod, before turning on your R-390A and pinning the carrier meter while you are setting the meter zero, adjust the shunted pot to about 5 ohms (the nominal value for meter zero). The 73JA usually does not insert easily unless you use a circular file to remove a small amount of metal from the rim of the pot mounting hole. And the 73JA usually does not mount well unless you grind a nut thinner and run the thin nut all the way down on the pot threads (the diameter of the pot mounting base is too small). A nice finishing touch is to use a lock nut assembly, Miller 10061. The finished mod is professional both in performance and appearance. It is one of the few mods worth doing to an R-390A.

The 1956 R-390A manual TM 11-856A has a stage gain chart for signal inputs at the balanced antenna input and test points E208 - E211 which is useful for trouble shooting a defective RF subchassis. The stage gain test for signal input at the balanced antenna input is also useful for identifying a defective RF subchassis, and sometimes for other problems. The test involves injecting a signal at the balanced antenna input and for each band determining the signal generator output required to produce -7 VDC at the DIODE LOAD terminal (terminal 14) on the rear panel with R-390A FUNCTION switch set to MGC, BANDWIDTH set to 8, RF gain control fully clockwise, BFO switch OFF, and all other controls in normal operating position. Peak ANT TRIM for each measurement, and tune the signal- for maximum voltmeter reading. TM-856A states that with this test setup the signal generator output required to produce -7 VDC at the diode load terminal should be less than 4 microvolts. You should use a precision 50-ohm source signal generator, and the calibration should be checked before doing this test. I use a rebuilt URM-25D which I check with a Tek 453 mod H scope. To check the calibration of a 50 ohm source signal generator, connect the output of the signal generator to a 50 ohm non-inductive resistor, set the output of the signal generator to 100,000 microvolts, and measure the voltage across the resistor. The voltage should be 280 millivolts peak-to-peak. I use a UG-971/U connector (twinax to C) and UG-636A/U (C to BNC) to connect the URM-25D to an R-390A balanced antenna input (through a short length of coax with BNC connectors). The signal generator output required to produce -7 VDC at the DIODE LOAD varies from one R-390A to another. For example, a 1956 Motorola (14-PH-56) required 3.0, 3.5, 2.0, 3.5, 1.0, and 2.0 microvolts at 0.5, 1.5, 7.5, 8.5, 16.5, and 26.5 MHz respectively, while a 1967 EAC (FR-36-etc.) required 2.0, 3.5, 3.5, 2.5, 2.0, and 2.0 microvolts respectively. Another 1967 EAC required 1.0 microvolts at most frequencies, with a few as high as 1.5 microvolts, and a few as low as 0.5 microvolts. There are sometimes variations within a band. For example, one EAC in the 7 MHz band required 7.0, 3.5, and 6.5 microvolts for -7 VDC at DIODE LOAD at 7.000, 7.500, and 7.999 MHz respectively. On the other hand, the 1956 Motorola required 3.0, 2.0, and 2.0 respectively. I don't know whether this indicates a problem with the EAC in the 7 MHz band, but I am inclined to think not because the EAC 7 MHz band sensitivity was a uniform 0.45 microvolts for a 10 dB S+N/N (AM mode, 4 KHz BW), while the Motorola 7 MHz band sensitivity was a uniform 0.55 microvolts for a 10 dB S+N/N. However, another EAC which required about 4.0 microvolts for -7 VDC at DIODE LOAD at 0.5, 1.5, 7.5, 8.5, 16.5, and 26.5 MHz was defective (a defective LIMITER control which I found by turning the limiter control on and off while doing the DIODE LOAD test). So it is not always trivial to identify a defective R-390A with this test. As a general guideline, if 2.0 microvolts or less is required at several widely spaced frequencies to produce -7 VDC at DIODE LOAD, the R-390A under test is probably OK, while if 3.0 microvolts or more is required at most frequencies, then there may be a problem.

Another useful performance check is to measure the sensitivity for a 10 dB S+N/N ratio. The only equipment you need is a precision signal generator, such as a URM-25D. The R-390A LINE LEVEL

R-390 and R-390A Receivers

2000

meter, LINE METER switch, and LINE GAIN control are used to measure the noise and signal power. Connect the signal generator to the balanced antenna input through a UG-971/U and UG-636A/U as described above, set the BANDWIDTH to 4, BFO to OFF, RF gain control fully clockwise, and all other controls in normal operating position. Set the signal generator to any frequency in the R-390A tuning range, tune the signal generator signal for maximum carrier meter indication (peak ANT TRIM), and reduce the signal generator output to about 0.4 microvolts unmodulated. Set the LINE METER switch to 0 and adjust the LINE GAIN control for a reading of -10 on the LINE LEVEL meter. If no reading is obtained with maximum gain, reduce the LINE GAIN setting, change the LINE METER switch to -10, and adjust the LINE GAIN for a reading of -10 on the LINE LEVEL meter. Change the signal generator to 400 Hz modulation at 50% modulation, and adjust the signal generator output for a reading of VU on the LINE LEVEL meter. The signal generator output is now the 10 dB S+N/N sensitivity (for a URM-25D you will have to switch back to unmodulated CW to read the microvolts output from the 25D meter). An R-390A typically has between 0.4 and 0.5 microvolt sensitivity for a 10 dB S+N/N in AM mode for a 4 KHz BW using this method of measurement. When the sensitivity is measured using an external speaker and voltmeter connected across the speaker, the sensitivity tends to be somewhat better, about 0.3 microvolts. I don't know why. Perhaps the R-390A LINE METER is not as accurate as a precision voltmeter. Or perhaps the voltmeter I have been using to measure R-390A sensitivity is not as accurate as the R-390A LINE METER. In any case, this provides a quick and easy check of R-390A performance, provided the LINE METER circuits are not defective.

As a final performance check, disconnect all antennas, set the FUNCTION switch to AGC, set BANDWIDTH to 8, BFO to OFF, LIMITER to OFF, RF gain fully clockwise, frequency to 5.500 MHz, and all other controls in normal operating position (AUDIO RESPONSE set to WIDE). Adjust ANT TRIM for maximum noise. You should hear a definite increase in noise as you rotate the ANT TRIM. What you are doing is peaking the R-390A front-end noise. Set the LINE METER switch to -10 and LINE GAIN control fully clockwise. The LINE LEVEL meter should read no less than UV. Set the LINE METER switch to 0 and LINE GAIN control fully clockwise. The LINE LEVEL meter should read no more than UV.

Similar RF alignment and noise performance checks were published by Charles A. Taylor in his article "R-390A Alignment Chart" in *DX News* 48, 25 (May 11, 1981), pages 25-28. The other alignment procedures discussed in this article were developed by me and other HSN subscribers. [Lankford, Issue #29, pgs 2-8]

Collins Torsion Mechanical Filters For The R-390A

Recently while studying the feasibility of adding a noise blanker to the R-390A, I made a surprising (to me) discovery. For the non-crystal filter bandwidths, i.e., for the 2, 4, 8, and 16 KHz mechanical filter bandwidths, the 3rd order intercept (ICP3) and hence the 3rd order dynamic range (DR3) of an R-390A is determined mainly by the 1st IF amp, not by the front end as it should be.

The non-crystal filter bandwidth of an R-390A at pin 1 of V501, the grid of the 1st IF amp, is shown at right. When the front-end selectivity is included, at lower frequencies (say, below 5 MHz) the non-crystal filter bandwidth at pin 1 of V501 is somewhat narrower. But in any case, for non-crystal filter

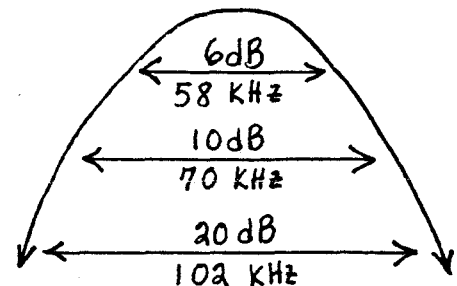

Typical R-390A Selectivity At Pin 1 of V501, 2 KHz BW or Greater

R-390 and R-390A Receivers

2000

bandwidths, the R-390A is quite broad up to the mechanical filters following the 1st IF amp. In other words, the R-390A was designed as a CW receiver, and AM was added as an afterthought.

Suddenly in a flash, a number of published statements which had seemed incorrect to me were explained. How had Sherwood gotten such uniform dynamic range measurements for the R-390A at 20, 10, and even 5 KHz tone spacings? My measurements using mechanical filter bandwidths were not nearly as uniform as his. Apparently he used the 0.1 or 1.0 KHz crystal filter bandwidths! And how did Rohde get a -4 dBm ICP3 for the R-390A? I never got better than about -12 dBm in the MW band using mechanical filter bandwidths. And in the SW bands I got much worse, typically about -24 dBm. Again, apparently he used one of the crystal filter bandwidths. To confirm my suspicions, I made extensive ICP3 measurements using the 0.1 crystal filter BW and got quite uniform ICP3 values at all frequencies and at various tone spacings, from 5 to 20 KHz. With the 1.0 KHz crystal filter BW, the 5 KHz tone spacing ICP3 drops off quite a lot to as low as -22 dBm for a Motorola I measured. That still translates into a DR3 of 74 dB. By contrast, with the 2 KHz BW the Motorola measured -52 dBm ICP3 and 54 dB DR3 for 5 KHz tone spacing. It appears that I made a mistake in a earlier HSN where I gave much higher values as typical. Or perhaps there is substantial variation from one R-390A to another. When some of the values I quoted in a draft of this article were questioned by Denzil Wraight, I could not reproduce my earlier measurements on an EAC of mine because I had modified it with a mechanical filter as described below. And when I measured the ICP3 and DR3 of a Motorola R-390A, I got lower values than I thought I got with my previously unmodified EAC. The most accurate statement I can make at present is that there is some variation from one R-390A to another, and perhaps substantial variation in ICP3 and DR3. In any case, the general trend is clear. The R-390A has significantly better 3rd order IMD performance in the 0.1 and 1.0 BW's than the 2, 4, 8, and 16 BW's, and the R-390A 3rd order IMD performance declines as frequency increases for the 2, 4, 8, and 16 BW's.

Further measurements revealed that RF voltages as high as 20 volts RMS can be present at the input to the R-390A mechanical filters when a weak signal is tuned near a strong signal. The maximum rated input of an R-390A mechanical filter is 5 volts RMS. It is remarkable that the R-390A mechanical filters routinely withstand 4 times their maximum rating. However, this may account for some of the occasional mechanical filter failures in R-390A's.

I have often wished for a 6 KHz BW filter for the R-390A, so this seemed like an ideal opportunity to kill 3 birds with one stone: add a mechanical filter immediately after the 3rd mixer which would provide (1) a 6 KHz BW while refining the 4, 2, 1.0, and 0.1 BW's, (2) improve the non-crystal filter ICP3 and 3rd order dynamic-range within about 50 KHz of the tuned frequency, and (3) protect the R-390A mechanical filters from excessive signal levels.

Of course, this is easier said than done. I am sure I am not the first person to contemplate adding a filter after the 3rd mixer. The problem is space. There is not much spare room in the small compartment where such a filter would naturally be installed. An R-390A N-type filter is too large to fit. An FA type Collins filter would barely fit, but try finding an F455FA60 at a reasonable price. Six years ago Collins priced them at \$290 for one. An FD filter is the same size as an FA filter, but an FD filter requires other components for impedance matching because the FD filters are 2000 ohms source and load.

Nevertheless, I began prototyping with an FD58 to verify the feasibility of such a mod. Those results are related in my hand written notes "Collins FD mechanical filter for the R-390A." The FD58 circuit never progressed beyond breadboard form, with the filter and impedance matching components sitting on a small piece of wood on top of the RF deck, with connections made via wires running through a spring hole and via a tube test socket. However, the FD58 breadboard circuit permitted me to confirm the feasibility and desirability of such a mod.

R-390 and R-390A Receivers

2000

Meanwhile, the search continued for a suitably small filter. Ceramic filters were considered, but rejected because of the difficulty of obtaining ceramic filters with uniform specs. I could get high quality, tightly spec'ed ceramic filters directly from Murata of NTKK, but I would have to order about 100 filters for about \$2000. I could not see myself going into the filter peddling business just to get a few small, tightly spec'ed, 6 KHz BW filters. And what good is a mod if others can not easily reproduce it?

Fortunately, Collins came to the rescue with their low cost series of torsion mechanical filters. I did not know much about Collins torsion mechanical filters when I ordered them; only that they were small, about the size of a 16 pin IC, that they cost \$76.81 each, and that the 6 dB and 60 dB specs were good, namely 5.5 KHz min. and 11 KHz max. respectively for the AM filter.

I also knew that the Collins torsion mechanical filters were 2000 ohms source and load, so that impedance matching would be required. I guessed correctly that the same impedance matching circuit I used for the FD58 would work for the torsion filter, and because the torsion filter was much smaller than an FD filter, that everything would fit inside the 3rd mixer compartment.

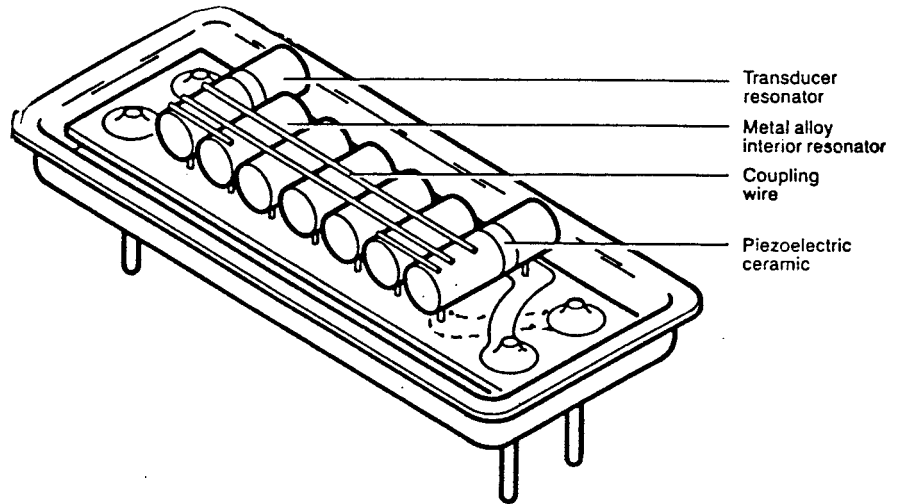

Before and after schematics of the mod are shown. A PC board layout is also given.

Before

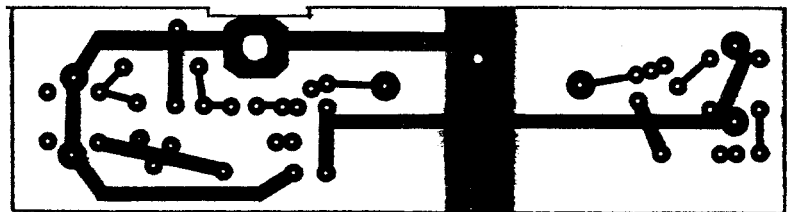
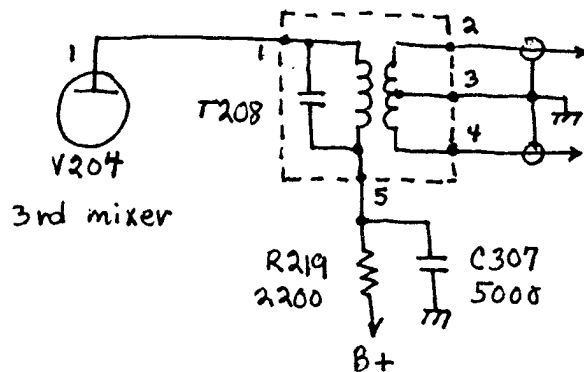

R-390 and R-390A Receivers

2000

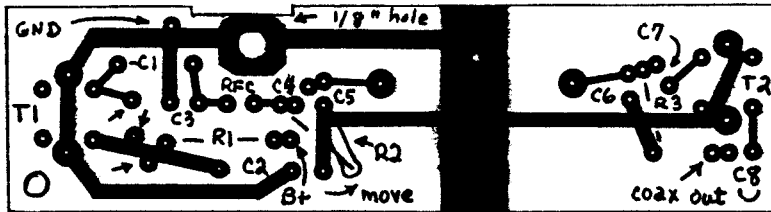

Another view of the PC board with information on the parts layout is given above. The 1/8-inch hole in the ground trace at the top is for mounting the PC board with a 4-40 screw in the side of the mixer compartment; see (4) in the simplified mixer compartment diagram below. The shallow notch in the PC

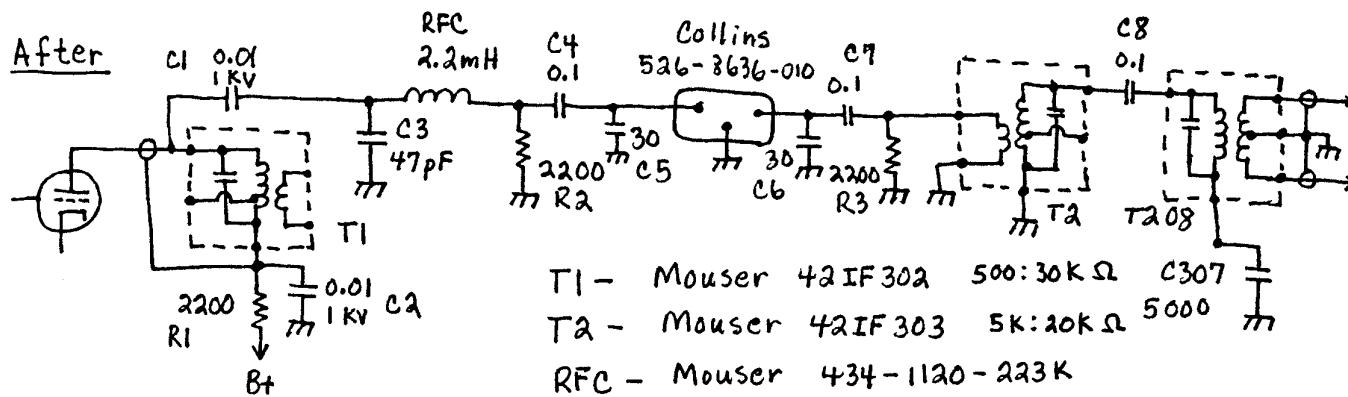

- T1 - Mouser 42IF302 500:30KΩ C307
- T2 - Mouser 42IF303 5K:20KΩ 5000
- RFC - Mouser 434-1120-223K
- R1 - half watt
- R2, R3 - 1/4 watt } Radio Shack
- C4, C7, C8 - 0.1, 50V monolithic (RS 272-109)
- C3, C5, C6 - small 50V ceramics
- C1, C2 - 0.01, 1KV (see text)

Note that R219 has been removed from the R-390A.

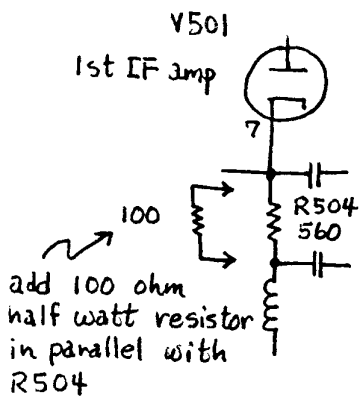

board above the mounting hole is to clear the ground lug which is part of the mounting arrangement; see below. The two holes in the bottom corners of the PC board are for nylon bolts and nuts which are used as standoffs to prevent the bottom of the PC board from accidentally shorting to the metal side of the mixer compartment. For mounting, the existing 4-40 screw is removed and replaced by a 1/2-inch long 4-40 screw. Also, an R-390A type ground lug is added. An exploded detail of the PC board mounting arrangement is given below. The miniature coax from mixer tube to PC board (1), the stranded insulated wire from standoff (B+) to PC board (2), and the miniature coax from T208 to PC board (3) are shown in simplified form below. Most of the R-390A parts have been omitted from the sketch for clarity. The miniature coax and wire run underneath all R-390A parts and connecting wires. Some details for attaching

R-390 and R-390A Receivers

2000

the miniature coax to the PC board are also given below. The PC board layout can be improved by moving the trace and pad for one end of R2 as shown above.

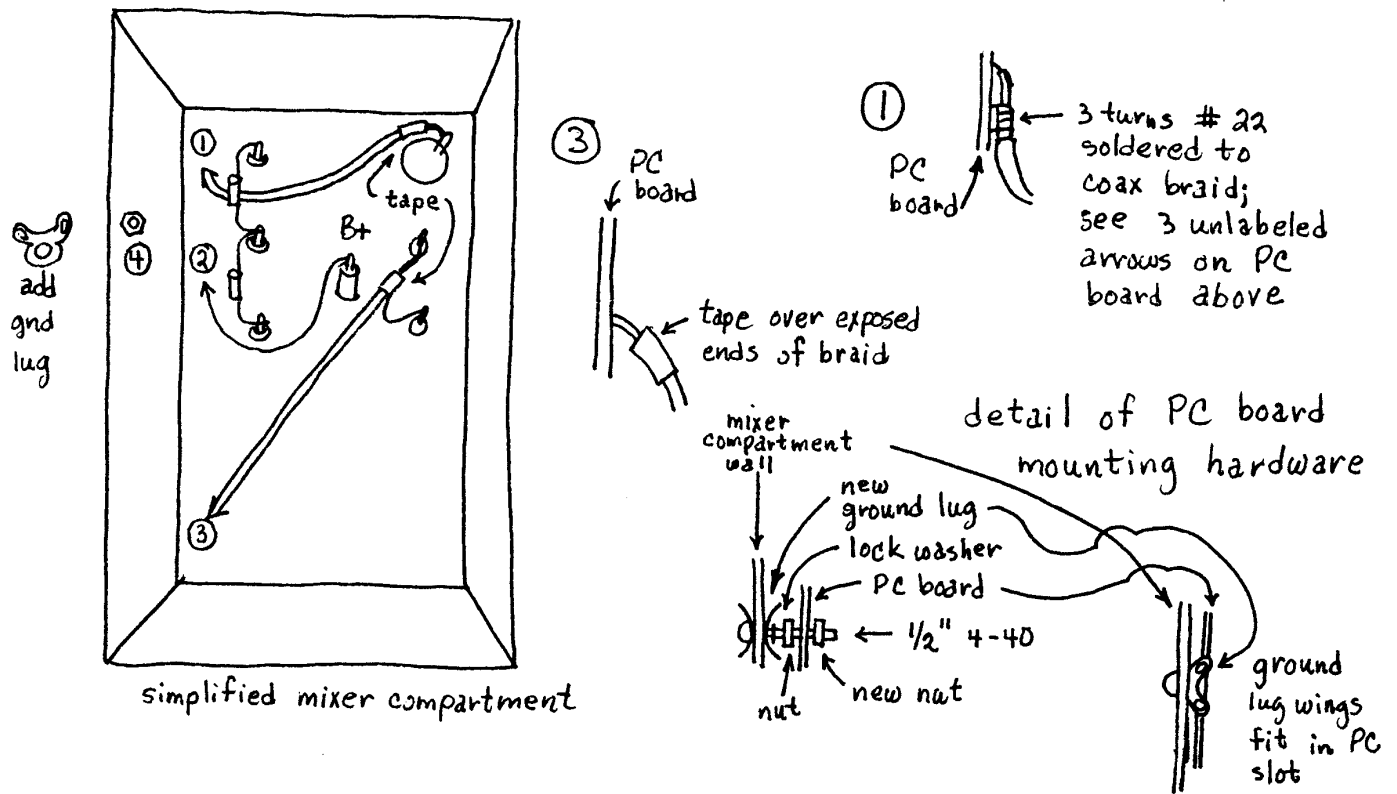

R-390 and R-390A Receivers

2000

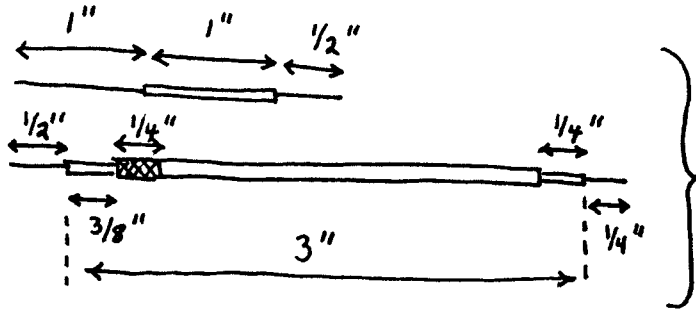

to R-390A IF transformer
from PC board

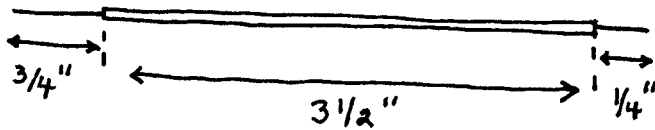

white with red tracer,
to B+ lug from PC board

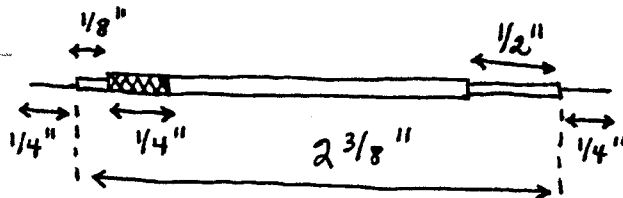

to R-390A mixer
from PC board

Lengths of the miniature coax and lead dressing are given above. Actually, I used Teflon insulated shielded hookup wire which is sturdier than miniature coax. Exposed edges of braid were taped with Scotch 27 Glass Cloth Electrical Tape, 1/2 inch wide, available from Amidon. It is important not to introduce shorts, especially around the mixer tube socket where high voltages are present.

The transformers T1 and T2 are standard (SUMDA) miniature 455 KHz IF transformers. T1 is a 500:30K ohm, 22:1 turns ratio, while T2 is a 5K: 20K ohm, 6:1 turns ratio. I did not know if T1 would safely carry 200 - 300 VDC, so I tore one apart and examined the internal construction. It looks like it would carry 1000 VDC. I also did not know if the current rating of T1 was adequate for the mixer current. So after 20 hours of use I removed T1, tore it apart, and inspected the coil. There was no evidence of internal heating. However, I cannot guarantee the safety or reliability of this transformer, only that it appears to be safe and reliable. Consequently, I assume no responsibility or liability for this mod. The primaries of both transformers are tapped, and the pin-out on one side of each consists of three pins. The middle pin was cut off with miniature diagonal cutters to simplify mounting the transformers. This pin should not be cut off too close to the insulated base; otherwise the transformer primary may open.

C1 and C2 must be 0.01, 1000 volt disc ceramics, and C2 must be small enough to clear internal R-390A parts. With a different PC board layout, C2 could be placed at the end of the PC board beside T1, and then the size of C2 would not be critical. Naturally I discovered this after the PC board was etched as I attempted to install the PC board.

The trace for mounting R2 should be moved slightly as shown, or the leads of R2 can be curved slightly so that R2 does not cover the B+ wire hole.

R-390 and R-390A Receivers

2000

R2 and R3 may be omitted for a slight increase in signal throughput. They are artifacts of the breadboard version where I tried different circuit variations to minimize passband ripple. They are also the preliminary steps in developing a diode switched multi-filter board.

RFC and C3 form an L matching network to match the high impedance of the mixer and T1 to the 2000-ohm source required by the filter. You may use 2000-ohm resistors for R2 and R3 if they are handy, but don't expect any noticeable improvement.

There is some signal leakage past the filter with the Mouser radial lead choke specified. To eliminate all signal leakage, you should use an Amidon FT-50-43 ferrite toroid core ($\mu = 850$, $A_L = 0.52$ microhenrys per turns squared, $L = 0.52 t^2$ microhenrys) with 62 turns of #30 enameled copper wire. The signal leakage was discovered after the PC board was etched. A different PC board layout is required for correct toroid mounting.

When the R-390A 8 KHz BW filter is used, the 80 dB BW with the Mouser choke is 10.5 KHz, so there is really no need for the toroid choke when the AM torsion filter is used. It might be worthwhile to use the toroid choke if the 2.5 KHz BW SSB torsion filter is used for this mod.

The Collins low-cost torsion filters are truly remarkable. Low cost does not mean cheap, either in appearance or performance. The torsion filters are small, about the size of a 16 pin dual in-line IC. The case is metal, while the bottom is epoxy fiberglass PC board construction, apparently plated through, with press-fitted pins. I can attest to the fact that the pins are well attached because I have removed and reinstalled some of them several times. Some torsion filters are assembled with standard low-temperature solder. In that case, the solder around the bases of the pins will flow up inside the case if the filter is soldered or unsoldered upside down. You can fix that by holding the case right side up, applying the hot iron tip to the pin for a moment, and the solder will flow back out. Then desoldering braid can be used to restore the pins to original. As I have said many times before, ChemWik Lite 0.100 desoldering braid is the only desoldering braid which really works well.

My original PC board had a small copper foil barrier fitted into a slot cut across the center of the PC board and soldered to the ground plane. My current PC board has no such barrier because careful measurement revealed it was unnecessary, at least for the AM filter.

The torsion filters are low loss, but the L matching network adds additional loss, enough loss to slightly desensitize the 390A. Fortunately, this loss can be mostly recovered by adding a 100 ohm half watt resistor in parallel with R504, the 1st IF amp cathode resistor. One end of R504 is attached to a lug on the end of the bandswitch wafer, the other end to an insulated feedthrough; see the sketch at right. Use desoldering braid to remove excess solder from the lug and feedthrough, form a small loop in one end of the 100 ohm resistor lead (Radio Shack half watt works well), push the loop onto the feedthrough using the tip of a screwdriver blade (the loop should be tight enough to hold the resistor in place as you solder it), solder the feedthrough connection, and connect and solder the other end of the 100 ohm resistor at the bandswitch wafer lug.

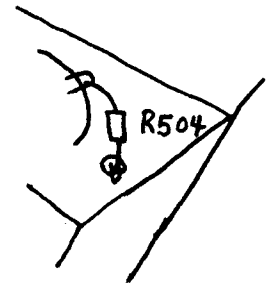

To install and tune the filter, first remove the 390A RF deck, remove R219, and remove the insulated wire (white with blue tracer) from pin 1 of V204 to T208. Next install a long length of insulated wire at the B+ insulated standoff, and a long length of mini-coax at T208, and bring these two wires through the rack spring hole in the mixer compartment. Reinstall the RF deck. Use a tube test socket to extend V204. Place a 6 inch by 6 inch piece of 1 inch thick wood on top of the RF deck. Attach the completed PC board. Turn on the R-390A, inject a signal generator signal (or tune a CAL marker) and peak T208, T2, and T1 in that order. Disconnect the PC board, remove the RF deck, and reinstall the PC

R-390 and R-390A Receivers

2000

board in the mixer compartment (remove the temporary mini coax from T208 and install the final mini coax, and trim the stranded insulated wire from the B+ insulated standoff to an appropriate length, about 3 1/2 inches long). The mini coax at the input side of the PC board should be the same as was used for the outboard tune-up. The PC board ground connection is a short length of #24 tinned solid copper wire from the PC board ground pad to the ground lug. Reinstall the RF deck, and re-peak T208.

The low-cost torsion filters are available in AM, 6 KHz BW, part no. 526-8636-010, SSB, BW 2.5 KHz, part no. 526-8635-010, and CW, BW 0.5 KHz, part no. 526-8634-010. Shape factors are typically slightly under 1:2, and the filters are capable of ultimate attenuation in excess of 100 dB. You should contact Bob Johnson, Principal Engineer, Filter Products, Rockwell International, 2990 Airway Avenue, Costa Mesa, CA 92626, phone (714) 641-5311 for prices and availability of these filters. The attenuation characteristics of a similar low-cost, 8 resonator, torsion filter is shown below. The spurs between 370 KHz and 390 KHz, at about 480 KHz and about 530 KHz are normal for mechanical filters. Even the spur at about 480 KHz will be attenuated to below 100 dB by an ordinary 455 KHz IF transformer, so these spurs are of no consequence unless the torsion filter is the only selectivity in your IF. This is, of course, not the case with an R-390A. [Lankford, Issue #30, pgs 2-8]

