

RESTRICTED

INSTRUCTION BOOK

FOR

Model RBM-5

SEMI-PORTABLE RADIO RECEIVING EQUIPMENTS

FREQUENCY RANGE

M.F.	H.F.
200 to 2000 Kcs.	2 to 20 Mcs.

TYPES OF RECEPTION

C.W. Telegraphy (A-1)
M.C.W. Telegraphy (A-2)
Telephony (A-3)

POWER SUPPLY

Portable Field Operation 12 Volts D.C. from Portable Storage Batteries, Part of the Equipment	Base Station Operation 115 V. 60 Cycle Single Phase A.C.
-----------------------------------------------------------------------------------------------------------	----------------------------------------------------------------

RESTRICTED

This instruction book is furnished for the information of the commissioned, warranted, enlisted and civilian personnel of the Navy whose duties involve design, instruction, operation and installation of radio and sound equipment. The word, "RESTRICTED," as applied to this instruction book, signifies that this instruction book is to be used only by the above personnel, and that the contents of it should not be made known to persons not connected with the Navy.

*Manufactured for U. S. Navy Department
Bureau of Ships*

Contract NXsr-38081

Dated September 28, 1943

Tender and Stock Spare Parts

Furnished on Contract NXsr-42136

By

WESTINGHOUSE ELECTRIC & MANUFACTURING COMPANY
Radio Division, Baltimore, Maryland

SPECIAL NOTE

The preliminary copies of the Model RBM-5 Equipment instruction book do not contain the material listed below. This information will be included in the final instruction books for these equipments.

Section IX, Performance Curves.

Photographs and certain drawings indicated in the "List of Illustrations" by an asterisk (*) opposite the figure number.

Electric Shock

FIRST AID TREATMENT

Safety First—Regard electrical apparatus generally, and especially all current-carrying parts, as dangerous, irrespective of voltage. Exercise great care in handling, and avoid broad contacts such as are made by standing on a metal deck or in water.

Dangerous contact may result through lessened resistance when the skin and clothing are wet with perspiration. Contact with damp metal surfaces—decks, bulkheads, guns, machinery—may allow the current to ground through the moist skin and body.

Electric shock is due to current passing through the body—current actually passing—irrespective of the voltage. A pressure as low as 110 volts has caused death. Current passing through the body in the region of the heart is especially dangerous. In using electric breast drills avoid the possibility of a ground.

Usually electric shock does not kill instantly. Life can often be saved even though breathing has stopped.

1. Free the Victim from the Circuit Immediately. Use a dry non conductor (rubber gloves, clothing, rope, board) to move either the victim or the wire. Beware of using metal or moist material.

Shut off the current.

If necessary to cut a live wire, use an ax or hatchet with a dry wooden handle; turn your face away from the electrical flash.

2. Attend Instantly to the Victim's Breathing. Begin resuscitation at once on the spot. Do not stop to loosen clothing; every moment counts.

Resuscitation by the Prone Pressure Method of Artificial Respiration

GAS ASPHYXIATION—ELECTRIC SHOCK—DROWNING

Waste no time. When the patient is removed from the water, gas, smoke, or electric contact, get to work at once with your own hands. Send for the medical officer or nearest physician.

No reliance should be placed upon any special me-

chanical apparatus, as it is frequently out of order and often is not available when most needed. The patient's mouth should be cleared of any obstruction such as chewing gum or tobacco, false teeth, or mucus, so that there is no interference with the entrance and escape of air.

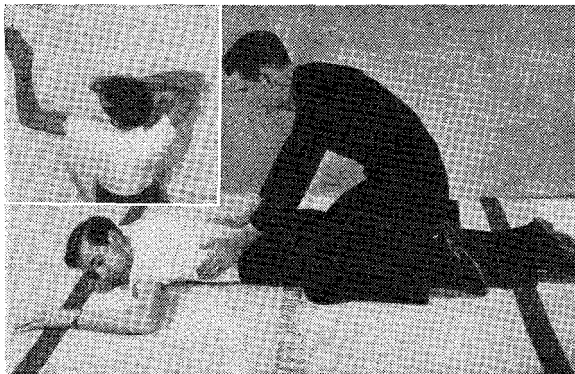

FIG. 1

Position—Lay the patient on his belly, one arm extended directly overhead, the other arm bent at elbow and with the face turned outward and resting on hand or forearm, so that the nose and mouth are free for breathing. (See Inset Fig. 1).

Kneel straddling the patient's thighs with your knees placed at such a distance from the hip bones as will allow you to assume the position shown in Figure 1.

Place the palms of the hands on the small of the back with fingers resting on the ribs, the little finger just touching the lowest rib, with the thumb and fingers in a natural position, and the tips of the fingers just out of sight. (See Fig. 1.)

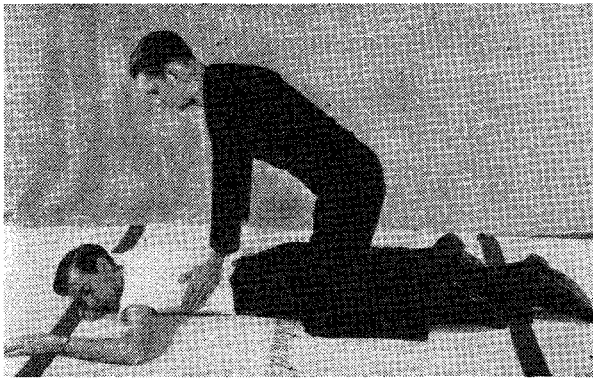

FIG. 2

First Movement—With arms held straight, swing forward slowly, so that the weight of your body is gradually brought to bear upon the patient. The shoulder should be directly over the heel of the hand at the end of the forward swing. (See Fig. 2.) Do not bend your elbows. This operation should take about two seconds.

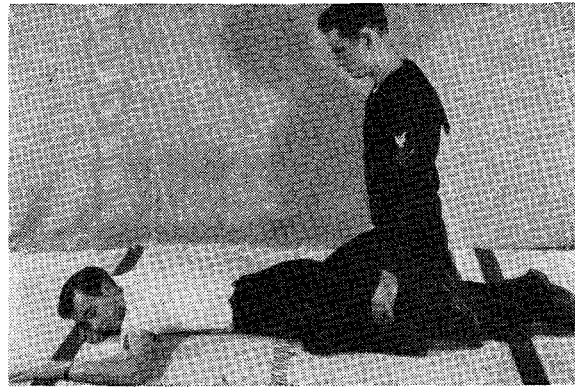

FIG. 3

Second Movement—Now immediately swing backward, so as to remove the pressure completely. (See Fig. 3.)

After two seconds, swing forward again. Thus repeat deliberately twelve to fifteen times a minute the double movement of compression and release, a complete respiration in four or five seconds.

Continue artificial respiration without interruption until natural breathing is restored. Do not get discouraged at the slow results that sometimes happen when resuscitating the apparently drowned. Efforts often have to be continued a long time before signs of life are apparent. Do not discontinue the efforts until certain that all chance is lost. Sometimes, even after several hours' work, recovery takes place.

As soon as this artificial respiration has been started and while it is being continued, an assistant should loosen any tight clothing about the patient's neck, chest, or waist. To keep the patient warm during artificial respiration is most important and it may be necessary to cover him with blankets and work through them, as well as to apply hot-water bottles, hot bricks, etc. Do not give any liquids whatever by mouth until the patient is fully conscious.

To avoid strain on the heart when the patient revives, he should be kept lying down and not allowed to stand or sit up. If the doctor has not arrived by the time the patient has revived, he should be given some stimulant, such as one teaspoonful of aromatic spirits of ammonia in a small glass of water or a hot drink of coffee or tea, etc. Continue to keep the patient warm and at rest.

Resuscitation should be carried on at the nearest possible point to where the patient received his injuries. As a general rule he should not be moved from this point until he is breathing normally of his own volition and then moved only in a lying position. Should

it be necessary, due to extreme weather conditions, etc., to move the patient before he is breathing normally, resuscitation should be carried on during the time that he is being moved.

A brief return of natural respiration is not a certain indication for stopping the resuscitation. Not infrequently the patient, after a temporary recovery of respiration, stops breathing again. The patient must be watched, and if natural breathing stops, artificial respiration should be resumed at once.

In carrying out resuscitation it may be necessary to change the operator. This change must be made without losing the rhythm of respiration. The relief operator should kneel behind the one giving the artificial respiration and at the end of the movement, the operator crawls forward while the relief takes his place. By this procedure no confusion results at the time of change of operator, and a regular rhythm is kept up.

Practice in the performance of artificial respiration on a volunteer subject should be obtained by everyone.

Table of Contents

	Page
Title Page.....	i
Special Note.....	ii
Rules for Resuscitation.....	iii
Table of Contents.....	v
Index of Illustrations.....	viii
I. PREFACE.....	1-1
Contractual Guarantee.....	1-1
Instructions to Operating Personnel Regarding Report of Failures.....	1-1
Instruction Book.....	1-2
Abbreviations.....	1-2
Definitions.....	1-3
II. INTRODUCTION AND GENERAL DESCRIPTION.....	2-1
Intent of the Design.....	2-1
Actual Design.....	2-1
List of Components with Weights and Dimensions.....	2-2
III. DETAILED DESCRIPTION.....	3-1
Mechanical Construction.....	3-1
Radio Receiver Assembly, Type CAY-46078-A.....	3-1
Transportation Case.....	3-1
Medium Frequency Receiver, Type CAY-46076-A.....	3-1
High Frequency Receiver, Type CAY-46077-A.....	3-1
Dynamotor Assembly, Type CAY-21387-A.....	3-2
Portable Storage Batteries, Type CES-19017.....	3-3
Slip Covers.....	3-3
Assembly of the Units—Field Operation.....	3-3
Base Station Equipment and Assembly.....	3-4
Rectifier Power Unit Type CAY-20086.....	3-4
Control Unit, Type CAY-23278.....	3-4
Dual and Single Base Station Operation.....	3-4
Mobile Spare Parts.....	3-4
Electrical Circuits—Medium Frequency Receiver.....	3-4
Antenna Compensation Circuit.....	3-4
Antenna Input Circuit.....	3-4
R.F. Amplifier Stage.....	3-5
Converter Stage.....	3-5
Heterodyne Oscillator Circuit.....	3-5
Intermediate Frequency Circuits.....	3-6
Automatic Volume Control.....	3-6
Electrical Circuits—High Frequency Receiver.....	3-6
Circuits Common to M.F. and H.F. Receivers.....	3-6
Beat Frequency Oscillator Circuits.....	3-6
Second Detector Circuit.....	3-6
First Audio Stage.....	3-7
Second Audio Stage.....	3-7
Audio Output Stage.....	3-7
Electrical Circuits—Power and Control Equipment.....	3-7
Dynamotor Assembly.....	3-7
Rectifier Power Units.....	3-8
Control Units.....	3-8
IV. INSTALLATION.....	4-1
Setting up the Equipment.....	4-1
Field Service (With Navy Model TBW-5 Transmitting Equipment).....	4-1
Packing the Equipment for Transportation.....	4-2
Field Service, Receiving (only) Installation.....	4-2
Base Station Operation (From Power Supply Lines).....	4-2

Table of Contents—Continued

For Dual Operation (A.C. Supplies).....	4-3
For Single Operation (A.C. Supplies).....	4-3
Repacking the Equipment After Base Station Operation.....	4-4
V. OPERATION	5-1
General.....	5-1
Controls (M.F. and H.F. Receivers).....	5-1
Selectivity Control.....	5-1
Gain Control.....	5-1
Phones Jack.....	5-1
Noise Limiter Control.....	5-1
Output Level Control.....	5-1
Reception Control.....	5-1
Antenna Compensation Control.....	5-2
Frequency Band Control.....	5-2
Tuning Control.....	5-2
Beat Note Control.....	5-2
Dial Light Dimmer Control.....	5-2
Station Log.....	5-2
Tuning Dial.....	5-2
Controls (Dynamotor Assembly).....	5-2
Intermediate Frequency Transmitter Side Tone Switch.....	5-2
High Frequency Transmitter Side Tone Switch.....	5-3
Medium Frequency Receiver Power Switch.....	5-3
M.F. and H.F. Phone Transfer Control.....	5-3
High Frequency Receiver Power Switch.....	5-3
Line Input Switch.....	5-3
Table Light Dimmer Control.....	5-3
Table Light.....	5-3
Line Voltmeter.....	5-3
Operating Adjustments.....	5-3
Warning.....	5-3
To Start and Stop the Equipment.....	5-4
Preliminary Tuning Adjustments (General).....	5-4
C.W. Signal—Preliminary Tuning Adjustments.....	5-4
C.W. Signal—Optimum Tuning Adjustments.....	5-4
M.C.W. Signal—Preliminary Tuning Adjustments.....	5-5
M.C.W. Signal—Optimum Tuning Adjustments.....	5-5
Voice Modulated Signal—Preliminary Tuning Adjustments.....	5-5
Voice Modulated Signal—Optimum Tuning Adjustments.....	5-5
Care of the Storage Batteries (Field Service).....	5-6
Base Station Check-up of the Storage Batteries.....	5-6
Operation of the Receivers from the Charging Generator Alone.....	5-6
Base Station Operation.....	5-6
Dual Operation.....	5-6
Single Operation.....	5-7
VI. PORTABLE STORAGE BATTERIES	6-1
Initial Placement in Service.....	6-1
Unpacking and Handling.....	6-1
Adding the Electrolyte.....	6-1
Initial Charge.....	6-1
Maintenance While in Field Service.....	6-2
Charging the Batteries (Field Service).....	6-2
Maintenance and Repairs (Field Service).....	6-3
Base Station Maintenance and Service.....	6-3
Base Station Charging Procedure.....	6-4
Full Charge Specific Gravity and Gravity Adjustments.....	6-4
Low Specific Gravity.....	6-4
High Specific Gravity.....	6-4
Adding Water.....	6-4
Discharging Rates and Capacity.....	6-5

Table of Contents—Continued

Battery Freezing Temperatures.....	6-5
Cleaning the Battery.....	6-5
Greasing Bolted Connections.....	6-5
VII. MAINTENANCE	7-1
Routine Inspection.....	7-1
Check for Looseness and Wear.....	7-1
Cleaning and Adjusting.....	7-1
Portable Storage Batteries.....	7-1
General	7-1
Replacements	7-1
Lubrication	7-1
Dynamotor Maintenance.....	7-1
VIII. TROUBLES, LOCATION AND REMEDY	8-1
Normal Sensitivity of the Receivers.....	8-1
Stage-by-Stage Trouble-Shooting Diagram.....	8-1
Weak or No Signals on All Bands.....	8-2
Check of Dynamotor Assembly or Rectifier Power Unit and Control Unit.....	8-2
Dynamotor Assembly Point-to-Point Resistance Table.....	8-2
Rectifier Power Unit Point-to-Point Resistance Table.....	8-2
Control Unit Point-to-Point Resistance Table.....	8-2
Tube Checks.....	8-2
Check of Socket Voltages.....	8-3
Voltage Chart, Receiver Tube Socket Contacts to Chassis.....	8-3
Check of Circuit Wiring and Components.....	8-4
Resistance Chart, Tube Socket Contacts to Chassis.....	8-4
Test of Audio Amplifier.....	8-5
Tests of Intermediate Frequency Amplifiers.....	8-5
Tests of I.F. Amplifiers, Stage-by-Stage.....	8-5
Alignment of I.F. Amplifiers.....	8-5
Test of Heterodyne Oscillator.....	8-6
Alignment of Heterodyne Oscillator.....	8-6
Test of R.F. Amplifier.....	8-6
R.F. Amplifier Circuit Check.....	8-6
Stage Gains Chart—M.F. and H.F. Receivers.....	8-6
Alignment of the R.F. Amplifiers (M.F. Receiver).....	8-7
R.F. Amplifiers Alignment Table (M.F. Receiver).....	8-7
Alignment of the R.F. Amplifiers (H.F. Receiver).....	8-8
R.F. Amplifier Alignment Table (H.F. Receiver).....	8-8
Weak or No Signals on Only One Band.....	8-8
Weak or No Signals, C.W. Only.....	8-8
Alignment of the Beat Frequency Oscillator.....	8-8
Measurements and Circuit Checks, General.....	8-9
Removing Receiver Shields.....	8-9
Voltage Measurements, General.....	8-9
Resistance and Continuity Measurements.....	8-9
Testing Tubes.....	8-9
Checking Interconnection Cables.....	8-9
IX. PERFORMANCE CURVES	9-
(Not supplied with preliminary instruction book)	
X. PARTS LISTS	10-1
TABLE I, LIST OF MAJOR UNITS.....	10-1
TABLE II, PARTS AND SPARE PARTS LIST BY SYMBOL DESIGNATIONS.....	10-2
TABLE III, PARTS LIST BY NAVY TYPE NUMBERS.....	10-38
TABLE IV, APPLICABLE COLOR CODES AND MISCELLANEOUS DATA.....	10-42
TABLE V, LIST OF MANUFACTURERS.....	10-43
XI. ILLUSTRATIONS	11-1

List of Illustrations

		Page
<i>Fig. 1*</i>	Navy Model RBM-5, Semi-Portable Radio Receiving Equipment, Portable Components Packed for Transportation—Front View (Photo C-)	11-1
<i>Fig. 2*</i>	Navy Model RBM-5, Semi-Portable Radio Receiving Equipment, Portable Components Packed for Transportation—Rear View (Photo C-)	11-2
<i>Fig. 3</i>	Navy Model RBM-5, Semi-Portable Radio Receiving Equipment, Portable Components Set Up for Field Service—Front View (Photo C-5471)	11-3
<i>Fig. 4*</i>	Navy Model RBM-5, Semi-Portable Radio Receiving Equipment, Portable Components Set Up for Field Service—Right Side View (Photo C-)	11-4
<i>Fig. 5*</i>	Navy Model RBM-5, Semi-Portable Radio Receiving Equipment, Portable Components Set Up for Field Service—Rear View (Photo C-)	11-5
<i>Fig. 6*</i>	Navy Model RBM-5, Semi-Portable Radio Receiving Equipment with Navy Model TBW-5 Portable Transmitting Equipment Portable Components Set Up for Field Service—Left Side View (Photo C-5598)	11-6
<i>Fig. 7*</i>	Navy Model RBM-5, Semi-Portable Radio Receiving Equipment, Portable Components Set Up for Field Operation, Protective Slip Covers in Position—Front View (Photo C-)	11-7
<i>Fig. 8*</i>	Navy Model RBM-5, Semi-Portable Radio Receiving Equipment, Portable Components Set Up for Field Operation, Slip Covers in Position—Rear View (Photo C-)	11-8
<i>Fig. 9*</i>	Radio Receiver Assembly, Type CAY-46078-A, Open with Receivers Removed from Transportation Case, One with Top Shield Removed (Photo C-)	11-9
<i>Fig. 10*</i>	Medium Frequency Receiver, Type CAY-46076-A—Front View—Shields Removed (Photo C-)	11-10
<i>Fig. 11*</i>	Medium Frequency Receiver, Type CAY-46076-A—Front Oblique Right Side View—Shields Removed (Photo C-)	11-11
<i>Fig. 12*</i>	Medium Frequency Receiver, Type CAY-46076-A—Rear Oblique Right Side View—Shields Removed (Photo C-)	11-12
<i>Fig. 13*</i>	Medium Frequency Receiver, Type CAY-46076-A—Rear View—Shields Removed (Photo C-)	11-13
<i>Fig. 14*</i>	Medium Frequency Receiver, Type CAY-46076-A—Rear Oblique Left Side View—Shields Removed (Photo C-)	11-14
<i>Fig. 15*</i>	Medium Frequency Receiver, Type CAY-46076-A—Front Oblique Left Side View—Shields Removed (Photo C-)	11-15
<i>Fig. 16*</i>	Medium Frequency Receiver, Type CAY-46076-A—Top View—Shields Removed (Photo C-)	11-16
<i>Fig. 17*</i>	Medium Frequency Receiver, Type CAY-46076-A—Bottom View—Shields Removed (Photo C-)	11-17
<i>Fig. 18*</i>	High Frequency Receiver, Type CAY-46077-A—Front View—Shields Removed (Photo C-)	11-18

*Not supplied in preliminary instruction book.

LIST OF ILLUSTRATIONS—Continued

	Page
<i>Fig. 19*</i> High Frequency Receiver, Type CAY-46077-A—Front Oblique Right Side View—Shields Removed (Photo C-)	11-19
<i>Fig. 20*</i> High Frequency Receiver, Type CAY-46077-A—Rear Oblique Right Side View—Shields Removed (Photo C-)	11-20
<i>Fig. 21*</i> High Frequency Receiver, Type CAY-46077-A—Rear View—Shields Removed (Photo C-)	11-21
<i>Fig. 22*</i> High Frequency Receiver, Type CAY-46077-A—Rear Oblique Left Side View—Shields Removed (Photo C-)	11-22
<i>Fig. 23*</i> High Frequency Receiver, Type CAY-46077-A—Front Oblique Left Side View—Shields Removed (Photo C-)	11-23
<i>Fig. 24*</i> High Frequency Receiver, Type CAY-46077-A—Top View—Shields Removed (Photo C-)	11-24
<i>Fig. 25*</i> High Frequency Receiver, Type CAY-46077-A—Bottom View—Shields Removed (Photo C-)	11-25
<i>Fig. 26*</i> Transformer, Antenna, Type CAY-47222-A, Part of Medium Frequency Receiver, Type CAY-46076-A (Photo C-)	11-26
<i>Fig. 27*</i> Transformer, Antenna, Type CAY-47223-A, Part of High Frequency Receiver, Type CAY-46077-A (Photo C-)	11-27
<i>Fig. 28*</i> Transformer Assembly, R.F., Type CAY-47224, a part of Medium Frequency Receiver, Type CAY-46076-A Input Circuits (Photo C-)	11-28
<i>Fig. 29*</i> Transformer Assembly, R.F., Type CAY-47224, a part of Medium Frequency Receiver, Type CAY-46076-A, Output Circuits (Photo C-)	11-29
<i>Fig. 30*</i> Transformer Assembly, R.F. Type CAY-47225-A, a part of High Frequency Receiver, Type CAY-46077-A Input Circuits (Photo C-)	11-30
<i>Fig. 31*</i> Transformer Assembly, R.F. Type CAY-47225A, a part of High Frequency Receiver, Type CAY-46077-A Output Circuits (Photo C-)	11-31
<i>Fig. 32*</i> Transformer, Oscillator, Type CAY-47220, a part of Medium Frequency Receiver, Type CAY-46076-A (Photo C-)	11-32
<i>Fig. 33*</i> Transformer, Oscillator, Type CAY-47221, a part of High Frequency Receiver, Type CAY-46077-A (Photo C-)	11-33
<i>Fig. 34*</i> Transformer, I.F.: Type CAY-47218, 1st I.F. Transformer; Type CAY-47214, 2nd I.F. Transformer and Type CAY-47212, 3rd I.F. Transformer, Parts of Medium Frequency Receiver, Type CAY-46076-A Shields Removed (Photo C-)	11-34
<i>Fig. 35*</i> Transformer, I.F.: Type CAY-47219, 1st I.F. Transformer; Type CAY-47215, 2nd I.F. Transformer and Type CAY-47213, 3rd I.F. Transformer, Parts of High Frequency Receiver, Type CAY-46077-A Shields Removed (Photo C-)	11-35
<i>Fig. 36*</i> Transformer, B.F.O., Type CAY-47216, a part of Medium Frequency Receiver, Type CAY-46076-A Shield Removed (Photo C-)	11-36
<i>Fig. 37*</i> Transformer, B.F.O., Type CAY-47217, a part of High Frequency Receiver, Type CAY-46077-A, Shield Removed (Photo C-)	11-37

*Not supplied in preliminary instruction book.

LIST OF ILLUSTRATIONS—Continued

	Page
<i>Fig. 38*</i> Dynamotor Assembly, Type CAY-21387-A—Front View—Shields Removed (Photo C-)	11-38
<i>Fig. 39*</i> Dynamotor Assembly, Type CAY-21387-A—Rear View—Shields Removed (Photo C-)	11-39
<i>Fig. 40*</i> Dynamotor Assembly, Type CAY-21387-A—Bottom View—Shields Removed (Photo C-)	11-40
<i>Fig. 41*</i> Dynamotor, Type CAY-21772-A, End Shields Removed (Photo C-)	11-41
<i>Fig. 42*</i> Portable Storage Battery, Type CES-19017, Battery Prepared for Transportation and Battery with Covers Removed (Photo C-)	11-42
<i>Fig. 43*</i> Mobile Spare Parts Box, Type CAY-10095, Cover Open (Photo C-)	11-43
<i>Fig. 44*</i> Rectifier Power Unit, Type CAY-20086, for 115 Volt, 60 Cycle, A.C. Operation—Front and Rear Views—Shields Removed (Photo C-)	11-44
<i>Fig. 45*</i> Rectifier Power Unit, Type CAY-20086 for 115 Volt, 60 Cycle, A.C. Operation—Top and Bottom Views—Shields Removed (Photo C-)	11-45
<i>Fig. 46*</i> Control Unit, Type CAY-23278, for 115 Volt, 60 Cycle, A.C. Operation—Front and Rear Views—Shields Removed (Photo C-)	11-46
<i>Fig. 47*</i> Control Unit, Type CAY-23278, for 115 Volt, 60 Cycle, A.C. Operation—Top and Bottom Views—Shields Removed (Photo C-)	11-47
<i>Fig. 48</i> Radio Receiver Assembly, Type CAY-46078-A Receivers in Case, Outline and Dimensions, Drawing T-7608638	11-48
<i>Fig. 49</i> Radio Receiver Assembly, Type CAY-46078-A, Receivers in Operation, Outline and Dimensions, Drawing T-7613094.	11-49
<i>Fig. 50</i> Medium Frequency Receiver, Type CAY-46076-A, and High Frequency Receiver, Type CAY-46077-A Outline and Dimensions, Drawing T-7613095	11-50
<i>Fig. 51</i> Dynamotor Assembly, Type CAY-21387-A Outline and Dimensions, Drawing P-7713084	11-51
<i>Fig. 52</i> Portable Storage Battery, Type CES-19017, Outline and Dimensions, Drawing P-7708690	11-52
<i>Fig. 53</i> Mobile Spare Parts Box, Type CAY-10095, Outline and Dimensions, Drawing T-7613184	11-53
<i>Fig. 54</i> Rectifier Power Unit, Type CAY-20086 for 115 Volt, 60 Cycle, A.C. Operation, Outline and Dimensions, Drawing T-7613096	11-54
<i>Fig. 55</i> Control Unit, Type CAY-23278 for 115 Volt, 60 Cycle, A.C. Operation, Outline and Dimensions, Drawing T-7613097	11-55
<i>Fig. 56</i> Medium Frequency Receiver, Type CAY-46076-A, Wiring Diagram, Drawing T-7611589	11-56
<i>Fig. 57</i> High Frequency Receiver, Type CAY-46077-A, Wiring Diagram, Drawing T-7611587	11-57
<i>Fig. 58</i> Dynamotor Assembly, Type CAY-21387-A, Wiring Diagram, Drawing T-7611585	11-58
<i>Fig. 59</i> Portable Storage Battery, Type CES-19017, Wiring Diagram, Drawing M-7408610	11-59

*Not supplied in preliminary instruction book.

LIST OF ILLUSTRATIONS—Continued

		Page
<i>Fig. 60</i>	Rectifier Power Unit, Type CAY-20086, for 115 Volt, 60 Cycle, A.C. Operation, Wiring Diagram, Drawing P-7711546	11-60
<i>Fig. 61</i>	Control Unit, Type CAY-23278, for 115 Volt, 60 Cycle, A.C. Operation, Wiring Diagram, Drawing T-7611584	11-61
<i>Fig. 62</i>	Medium Frequency Receiver, Type CAY-46076-A, Schematic Diagram, Drawing T-7611588	11-62
<i>Fig. 63</i>	High Frequency Receiver Type CAY-46077-A, Schematic Diagram, Drawing T-7611586	11-63
<i>Fig. 64</i>	Dynamotor Assembly, Type CAY-21387-A, Schematic Diagram, Drawing P-7711543	11-64
<i>Fig. 65</i>	Rectifier Power Unit, Type CAY-20086, for 115 Volt, 60 Cycle, A.C. Operation, Schematic Diagram, Drawing P-7711545	11-65
<i>Fig. 66</i>	Control Unit, Type CAY-23278, for 115 Volt, 60 Cycle, A.C. Operation, Schematic Diagram, Drawing P-7711544	11-66
<i>Fig. 67*</i>	Dynamotor, Type CAY-21772, Schematic Diagram, Drawing	11-67
<i>Fig. 68</i>	Radio Receiving Equipment, Model RBM-5, Interconnection Diagram, Portable Components Used in Field Service, Drawing P-7713096	11-68
<i>Fig. 69</i>	Radio Receiving Equipment, Model RBM-5, Interconnection Diagram, Components Used in Base Station Dual Operation, Drawing P-7713095	11-69
<i>Fig. 70</i>	Radio Receiving Equipment, Model RBM-5, Interconnection Diagram, Components Used in Base Station Single Operation, Drawing P-7713094	11-70
<i>Fig. 71*</i>	Transformer, Antenna, R.F. Assembly and Oscillator, Dimensional Drawings and Winding Data, Drawings , and	11-71
<i>Fig. 72*</i>	Transformers, I.F. Schematic B.F.O., Dimensional Drawings, and Winding Data, Drawings , and	11-72
<i>Fig. 73</i>	Stage-by-Stage Trouble-shooting Diagram, Drawing P-7709095	11-73
<i>Fig. 74</i>	Tube Socket Diagrams, Drawing P-7709096	11-74

*Not supplied in preliminary instruction book.

RESTRICTED

Navy Model RBM-5 Semi-Portable Radio Receiving Equipment

I. Preface

CONTRACTUAL GUARANTEE

1-1 The complete equipment, including all parts and spare parts, except vacuum tubes, storage batteries, rubber and material normally consumed in operation, is guaranteed for a period of ONE YEAR with the understanding that, as a condition of this contract, all items found to be defective as to design, material, workmanship or manufacture will be replaced without delay and at no expense to the Government; provided that such guarantee and agreement will not obligate the contractor to make replacement of defective material unless the failure, exclusive of normal expected shelf life deterioration, occurs within a period of ONE YEAR from the date of delivery of the equipment to and acceptance by the Government, and provided further, that if any part or parts (except vacuum tubes) fail or are found defective to the extent of ten per cent (10%) or more of the total number of similar units furnished under the contract (exclusive of spares), such part or parts, whether supplied in the equipment or as spares, will be conclusively presumed to be of defective design, and as a condition of contract subject to one hundred per cent (100%) replacement by suitable redesigned units.

Failure due to poor workmanship, while not necessarily indicating poor design, will be considered in the same category as failure due to poor design. Redesigned replacements which will assure proper operation of the equipment will be supplied promptly, transportation paid, to the Naval activity using such equipment upon receipt of proper notice and without cost to the Government.

All such defective parts will be subject to ultimate return to the contractor. In view of the fact that normal activities of the Naval Service may result in the use of the equipment in such remote portions of the world or under such conditions as to preclude the return of a defective item or unit prior to replacement without jeopardizing the integrity of Naval communications, the exigencies of the Service, therefore, may necessitate expeditious repair of such item or unit in order to prevent extended interruption of communications. In such cases the return of a defective item or unit for examination by the contractor prior to replacement will not be required. The re-

port of a responsible authority, including details of the conditions surrounding the failure, will be acceptable for effective adjustment under the provisions of this guarantee.

THE ABOVE PERIOD OF ONE YEAR WILL NOT INCLUDE ANY PORTION OF THE TIME THAT THE EQUIPMENT FAILS TO GIVE SATISFACTORY PERFORMANCE DUE TO DEFECTIVE ITEMS AND THE NECESSITY FOR REPLACEMENT THEREOF. ALL REPLACEMENT PARTS WILL BE GUARANTEED TO GIVE ONE YEAR OF SATISFACTORY SERVICE.

1-2 Vacuum tubes are suitable for use in this type equipment and subject to the above guarantee in all respects, except the service period will be based on a guarantee of fifty (50) hours life under full load conditions within a period of two years.

INSTRUCTIONS TO OPERATING PERSONNEL REGARDING REPORT OF FAILURES

1-3 Report of failure of any part of this equipment, during its service life, shall be made to the Bureau of Ships in accordance with current instructions. The report shall cover all details of the failure and give the date the equipment was placed in service. For procedure in reporting failure see Chapter 31 (mimeographed form) of the Manual of Engineering Instructions, or Bureau of Ships Radio and Sound Bulletin Number 7, dated July 1, 1942, or superseding instructions.

The blank spaces indicated below should be filled in by ship or station force immediately upon completion of the initial service installation. The date of acceptance by the Navy can be determined by the stamped acceptance plate located on the front panel of the M.F. Receiver. These dates are stamped in the sequence of month, day and year.

Contract NXsr-38081, Dated Sept. 28, 1943
Serial Number of Equipment
Date of Acceptance by Navy (Month)
(Day) (Year)
Date of Delivery to Contract Destination
(Month) (Day) (Year)
Date Placed in Service (Month)
(Day) (Year)

All requests or requisitions for replacement material should include complete descriptive data covering the part desired in the following form:

1. Name of part desired.
2. Navy Type Number (if assigned) (including prefix and suffix as applicable).
3. Model designation (including suffix of equipment in which used).
4. Navy Type designation (including prefix and suffix where applicable) of Major unit in which part is used.
5. Symbol designation of part.
6. (a) Navy drawing number.
(b) Manufacturers' drawing and part number.
7. Rating or other descriptive data.
8. Commercial designation.

INSTRUCTION BOOK

1-4 In the compilation of this Instruction Book, every effort has been made to provide the answer to every reasonable question which may arise in connection with the installation, efficient operation, and servicing of the Model RBM-5 Semi-Portable Radio Receiving Equipment. It has further been attempted to group the large amount of material this book contains in such a manner that any desired information pertaining to the equipments is most readily found. For greatest convenience in use, the drawings bound in the back of the book have been folded in a manner openly displaying their titles along the right margins. To preserve the full usefulness of this book, it is suggested that these marginal edges be reinforced by backing of paper or gummed tape, should they begin to show wear from handling.

1-5 To the uninitiated, the electrical circuits of the Model RBM-5 Semi-Portable Radio Receiving Equipment may appear quite complicated. Actually the various individual operating and control circuits are, for the most part rather simple, and it is only the wide choice of frequency bands and methods of operation provided which complicates the combined circuit of the equipment. Considerable pains have therefore been taken in Part III to describe each component circuit in some detail. On the pages which contain the photographs, drawings and diagrams will be found not only the complete circuit diagrams and actual wiring connections of all units, but also schematic representations of the various circuits. Where it may assist in further clarifying their function, portions of the circuit are also reproduced in simplified, elementary schematic form. Since these schematic diagrams, for the sake of clarity, frequently omit minor connections and components, the actual wiring diagrams should be consulted when tracing connections and in "troubleshooting".

1-6 Part X, "Parts List," supplies sufficient detailed information regarding the various components, suitably classified, to be valuable not only for parts replacement purposes, but also for servicing and repair work. Further, since the function and use of each component part is stated, frequent reference to this section is invited in connection with the study of the various circuit diagrams.

1-7 Attention is invited to the Tables of Typical Test Currents, Voltages and Resistance Values, appearing in Part VIII which show representative normal test equipment meter readings taken on the equipment in operation and should prove of value in connection with locating and remedying troubles in the equipment.

1-8 Attention also is invited to the "Stage-By-Stage Troubleshooting Diagram", Figure 73, which presents an easily followed block diagram, with paragraph references to the text of Part VIII for use when hunting trouble occurring in the equipment.

1-9 Before attempting to set up and operate the the Model RBM-5 Semi-Portable Receiving Equipment for the first time, read carefully not only Part IV of this instruction book, but also the preceding parts which lead up to it. Attention is invited to Part II enumerating additional parts required for an installation, not regularly furnished as part of the equipment.

ABBREVIATIONS

1-10 Throughout this book only such abbreviations as are in common usage have been employed and these sparingly. A number of these are listed below:

A.C.	alternating current
adj.	adjustable, adjustment
A.F.	audio frequency
A.V.C.	automatic volume control
amp.	ampere
ant.	antenna
bat.	battery
C.	capacitor
C.F.I.	crystal frequency indicator
C.W.	continuous wave (telegraphy)
D.C.	direct current, or double contact
DCC.	double cotton covered (wire)
DSC.	double silk covered (wire)
DPST.	double pole, single throw (switch)
fil.	filament
flex.	flexible
gen.	generator

gnd.....ground, ground connection, chassis
of the equipment

H.....henry (unit of inductance)

H.F.....high frequency

H.T.....high tension

H.V.....high voltage

I.C.S.....interior communication system
(inter-phone)

I.F.....intermediate frequency

J.....jack, connection terminal

kcs.....kilocycles

L.....symbol for coil, inductance

L.F.....low frequency

L.V.....low voltage

ma.....milliamperes

mcs.....megacycles (thousands of Kilocycles)

M.C.W.....modulated continuous wave, (tone
modulated telegraphy)

mfd.....microfarads

mmfd.....micro-microfarads (millionths of a
microfarad)

M.H.....milli-henry (thousandths of a henry)

M.F.....medium frequency

mod.....modulator, modulation

osc.....oscillator, oscillation

R.....resistor, resistance

Rec.....receiver, receiving

S.....switch

SC.....single contact

Ser.....Serial No., or series

SPDT.....single pole, double throw (switch)

T.....transformer

tel.....telephone, telephony

term.....terminal

trans.....transmit, transmitter

v.....volts

voice.....speech modulated transmission,
(radio telephony)

w.....watts

DEFINITIONS

1-11 The following definitions apply to certain terms as used in this instruction book:

1-12 "Ground"—The terms "ground" and "ground connection" throughout this instruction book are used to denote the electrical potential of the structure, and any connection thereto. Since the chassis, shields, control panels and cases of all major units of the equipment are electrically bonded to each other, connection to the chassis or mechanical structure of the various units represents a "ground" connection.

1-13 "Type of Emission"—Type of radio wave, i.e., "C.W.", "M.C.W." or "voice".

1-14 "Direct Ray," or "Ground Wave"—Radio wave which travels in a direct line from the antenna transmitting the signal to that receiving it, without reflection or appreciable refraction.

1-15 "Reflected Ray," or "Sky Wave"—Radio wave which travels between the transmitting and receiving station by way of "reflection" from the Kenelly-Heaviside layer ("Ionosphere").

1-16 "Tuned Circuit"—An inductance and a capacitance, in parallel, usually connected in the grid or plate circuit of a vacuum tube.

1-17 "Side Tone"—The signal heard in his own head phones by the radio operator, while he is transmitting by telegraph or voice.

1-18 "Carrier" or "Carrier Wave"—The continuous wave signal which "carries" modulation for M.C.W. or radio telephony. Only the carrier is transmitted between words in voice transmission.

1-19 "Pentode"—A five-element vacuum tube which contains a filament or cathode, grid, screen grid, suppressor grid, and plate.

1-20 "Tetrode"—A four-element vacuum tube which contains a filament or cathode, grid, screen grid, and plate.

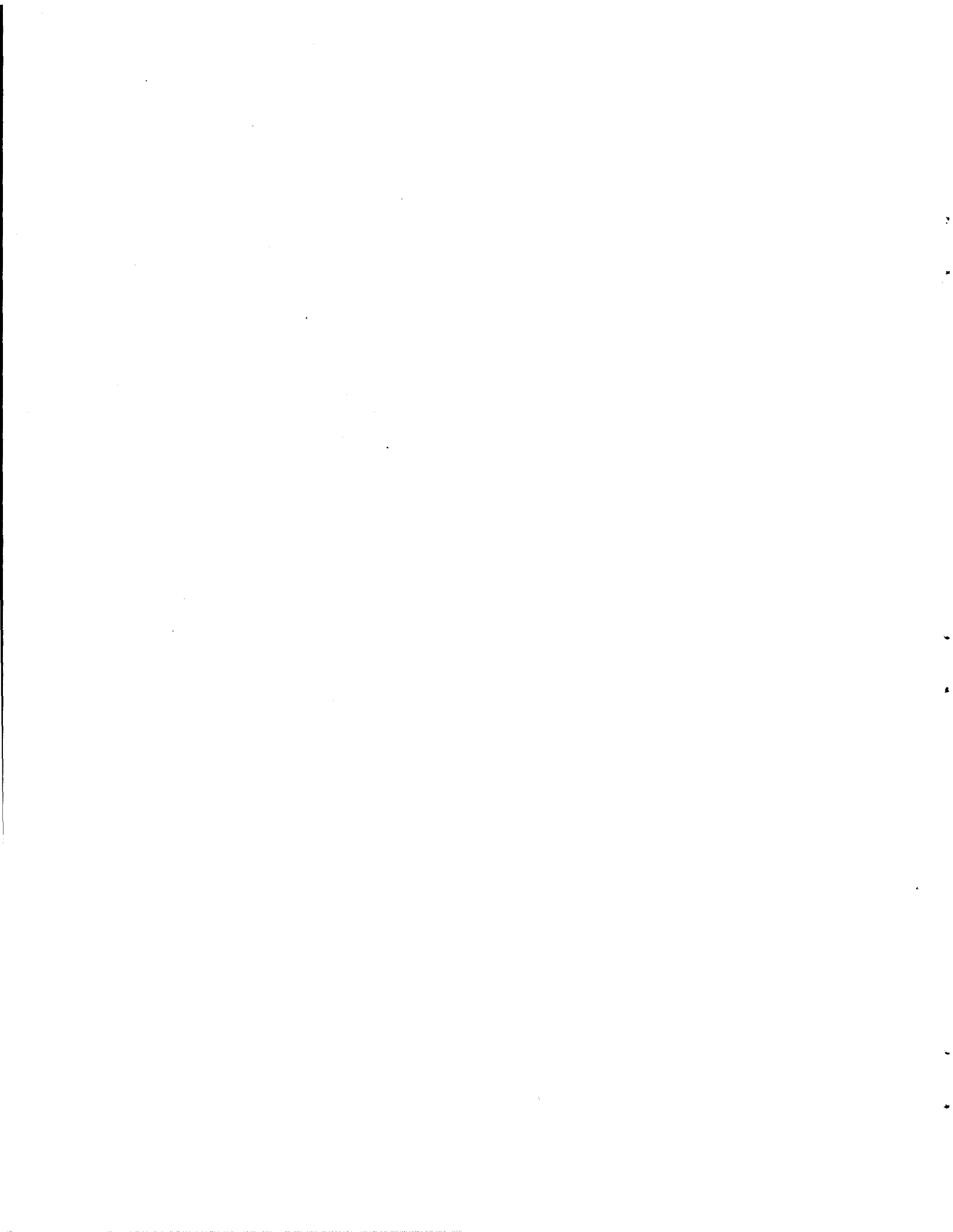

II. Introduction and General Description

INTENT OF THE DESIGN

2-1 The Navy Model RBM-5 Semi-Portable Radio

Receiving Equipment is primarily intended for use in portable service which involves transportation over and use in rough and wet country. In addition, they are suitable for many varied applications to which radio receiving equipment may be put by the Naval services. This equipment is particularly intended for use with complete radio transmitting equipment of the portable type, in which type of service it becomes an integral part of a radio transmitting and receiving station at an advanced base. It is also suitable for independent operation, separate and distinct from any transmitting equipment, for radio reception at permanent or semi-permanent base stations, Naval radio shore stations and aboard Naval vessels.

2-2 The following accessories (not supplied or described herein) are necessary for a complete Transmitting-Receiver installation:

- (1) Transmitting Equipment and Antenna Installation.
- (2) Frequency Measuring Equipment.
- (3) Two pairs of Navy Type 49016 Telephone Headsets complete with cords and plugs.
- (4) Equipment for charging storage batteries or suitable line power supply.

2-3 The following accessories (not supplied or described herein) are necessary for a Receiving (only) installation:

- (1) Two pairs of Navy Type 49016 Telephone Headsets complete with cords and plugs.
- (2) Frequency Measuring Equipment.
- (3) Equipment for charging storage batteries, or suitable line power supply.
- (4) Antenna Installation.

ACTUAL DESIGN

2-4 The equipment supplied on Contract NXsr-38081 consists of various combinations of the following several major units:

Type CAY-46078-A—RADIO RECEIVER ASSEMBLY, which includes 1 each, Type CAY-46076-A MEDIUM FREQUENCY

RECEIVER, and Type CAY-46077-A HIGH FREQUENCY RECEIVER (listed separately below) in a water tight Transportation Case.

Accessories for Type CAY-46078-A in Accessory Bag.

Type CAY-46076-A — MEDIUM FREQUENCY RECEIVER, Frequency Range 200-2000 Kilocycles, complete with One Set of Tubes, a part of Type CAY-46078-A RADIO RECEIVER ASSEMBLY.

Type CAY-46077-A—HIGH FREQUENCY RECEIVER, Frequency Range 2 to 20 Megacycles, complete with One Set of Tubes, a part of Type CAY-46078-A RADIO RECEIVER ASSEMBLY.

Type CAY-21387-A—DYNAMOTOR ASSEMBLY, for operation of the equipment from Portable Storage Batteries, in a watertight case.

Type CES-19017—PORTABLE STORAGE BATTERY, 12 volts, with Carrying Tray, Straps and Handle. (Two Batteries provided with each equipment).

Type CAY-10095 — MOBILE SPARE PARTS BOX.

Type CAY-20086—RECTIFIER POWER UNIT, for operation of the equipment from 115 Volt, 60 Cycle, Single Phase A.C. Line Supply.

Type CAY-23278—CONTROL UNIT, for operation of the equipment from 115 Volt, 60 Cycle Single Phase, A.C. Line Supply. Spare Parts as listed in Part X.

2-5 THE RBM-5 RADIO RECEIVER ASSEMBLY

consists of a watertight Transportation Case, fabricated from aluminum alloy sheet and angles, one MEDIUM FREQUENCY RECEIVER and one HIGH FREQUENCY RECEIVER. The Transportation Case serves to protect the Receivers while the equipment is transported and acts as a cabinet when the equipment is in operation. It is fitted with a watertight cover which fits over the front of the case

and watertight closures over the two ports in the back of the case through which electrical connections are made to the Receivers. The two Receivers are individually shock-mounted inside the case which is fitted with handles for easy carrying. Three legs are provided which mount the RADIO RECEIVER ASSEMBLY at operating height. A set of chains and brackets to attach the cover of the case to permit its use as an operating table when the equipment is used in the field, are supplied as accessories.

2-6 The MEDIUM FREQUENCY RECEIVER and the HIGH FREQUENCY RECEIVER are each built on a separate individual aluminum alloy chassis with panels, shields and shock-mounts. Each Receiver, within its frequency range, contains all parts and circuits necessary for reception of radio signals when connected to a conventional type antenna, provided with a pair of Navy Type 49016 Telephone Headsets (not supplied as part of the equipment) and supplied with suitable operating voltages.

2-7 The DYNAMOTOR ASSEMBLY is assembled on an aluminum alloy chassis with panel, and is enclosed in a watertight carrying case. When provided with Direct Current at a potential of 12 volts from the PORTABLE STORAGE BATTERIES it delivers proper operating potentials to either the MEDIUM FREQUENCY RECEIVER or the HIGH FREQUENCY RECEIVER or both simultaneously. The RECTIFIER POWER UNIT and CONTROL UNIT are each built on an individual zinc plated steel chassis with panel, and enclosed in an individual case.

LIST OF COMPONENTS WITH WEIGHTS AND DIMENSIONS

2-8 The Model RBM-5 Semi-Portable Radio Receiving Equipment is supplied complete with all units required for field operation. In addition, certain other units are supplied to permit operation of the equipments from various base station power line supplies. Following are given the weights and measurements of all units supplied on contracts covering these equipments. Paragraph 2-9 will indicate the several combinations of units in which these equipments are supplied, and the total weights of these combinations.

2-9 RADIO RECEIVER ASSEMBLY—Type CAY-46078-A

Height — $12\frac{7}{16}$ "
 Width — $29\frac{1}{16}$ "
 Depth — $19\frac{7}{16}$ "
 Weight — 95 lbs.
 (Including weight of the Receivers)

MEDIUM FREQUENCY RECEIVER—Type CAY-46076-A

Height — $9\frac{3}{4}$ "
 Width — $12\frac{7}{16}$ "
 Depth — $17\frac{1}{16}$ "
 Weight — 30 lbs.

HIGH FREQUENCY RECEIVER—Type CAY-46077-A

Height — $9\frac{3}{4}$ "
 Width — $12\frac{7}{16}$ "
 Depth — $17\frac{1}{16}$ "
 Weight — 30 lbs.

DYNAMOTOR ASSEMBLY—Type CAY-21387-A

Height — $10\frac{7}{16}$ " (Handle Down)
 Width — 16"
 Depth — 12"
 Weight — 30 lbs.

PORTABLE STORAGE BATTERY—Type CES-19017

Height — $12\frac{1}{2}$ "
 Width — $11\frac{3}{4}$ "
 Depth — $8\frac{3}{4}$ "
 Weight — 41 lbs.

MOBILE SPARE PARTS BOX—Type CAY-10095

Height — $12\frac{3}{4}$ "
 Width — 21" (Handle Folded)
 Depth — $11\frac{5}{8}$ "
 Weight — 34 lbs.
 (Including spare parts)

RECTIFIER POWER UNIT, 115 VOLT 60 CYCLE A.C.—Type CAY-20086

Height — $9\frac{1}{16}$ "
 Width — $7\frac{7}{8}$ "
 Depth — $14\frac{3}{16}$ " (approx.)
 Weight — 31 lbs.

CONTROL UNIT, 115 VOLT 60 CYCLE A.C.—Type CAY-23278

Height — $8\frac{13}{16}$ "
 Width — 7"
 Depth — 8"
 Weight — 11 lbs.

EQUIPMENT SPARE PARTS (See Part X, Table IV)

Stock Spare Parts (Shipped in Bulk) See Part X.

All equipment and mobile spare parts are packed in two shipping containers.

Box No. 1 contains all equipment and mobile spare parts.

	Uncrated	Crated
Height —		45"
Width —		35"
Depth —		34"
Weight —	325	506 lbs.
Volume —		30.98 cu. ft.

Box No. 2 contains two gallons of Acid for Storage Batteries.

	Uncrated	Crated
Height —		26"
Width —		13"
Depth —		8"
Weight —	21 lbs.	84 lbs.
Volume —		1.80 cu. ft.

III. Detailed Description

MECHANICAL CONSTRUCTION

Radio Receiver Assembly, Type CAY-46078-A

3-1 The RADIO RECEIVER ASSEMBLY consists of two separate Receivers in an aluminum alloy Transportation Case. Figures 1 to 9 inclusive show the general appearance and arrangement. Referring to Figures 3 and 9, the MEDIUM FREQUENCY RECEIVER is installed in the left-hand compartment of the Transportation Case and the HIGH FREQUENCY RECEIVER is located in the right-hand compartment. Figures 1 and 2 show the Transportation Case with watertight cover and port closures in position as it appears while the equipment is ready for transportation.

Transportation Case

3-2 The Transportation Case is strongly built of aluminum alloy sheet and angles, electrically welded. It is provided with a cover which completely closes the front of the case. A rubber gasket and tightening screws provide a watertight seal when the cover is in position and the screws tightened. Two round ports at the rear of the Transportation Case permit power connections to be made to the receivers. Screw type port covers and rubber gaskets provide a watertight seal for these ports. The Transportation Case is provided with three sockets for attaching legs which support the unit at operating height when the equipment is used in the field. Chains and brackets are provided which allow the top of the case to be used as an operating table in the field, as shown in Figures 3 to 8, inclusive. The case has a handle on each end for carrying. Schematic Diagrams and Wiring Diagrams for each receiver are provided inside the cover, in watertight transparent cases.

Medium Frequency Receiver— Type CAY-46076-A

3-3 The MEDIUM FREQUENCY RECEIVER is constructed on a chassis formed from aluminum alloy sheet bent into conventional chassis form, and spot-welded at each corner. To this chassis are welded two legs at the rear and panel-supporting

gussets at the front. The front panel is bolted to these gussets.

3-4 The entire receiver chassis is shock-mounted inside the Transportation Case by an especially effective shock-mounting assembly. The receiver chassis is supported by four "Lord" vertical snubbing type shock-mounts on the bottom of the frame. The front and rear shock-mounts on each side of the receiver chassis are tied together by means of stainless steel rails running from the front to the rear of the unit. These rails engage channels fastened to the bottom of the Transportation Case and are clamped rigidly in position by thumb-screws. By releasing these thumb-screws either receiver, or both may be slid from the case for inspection, maintenance or adjustment.

3-5 The electrical parts of the receiver are arranged as follows: On the top of the chassis are located the main "four-gang" tuning capacitor; all vacuum tubes; the intermediate frequency amplifier transformers; beat frequency oscillator transformer; low-pass filter reactors; eight by-pass filter capacitors and the output transformer. On the under side of the chassis are the antenna; R.F. and oscillator transformer assemblies; three main resistor-capacitor boards; and three small resistor-capacitor boards; and the remaining filter and by-pass capacitors. The exact locations of the individual electrical components which comprise the receiver are shown on the photographs, Figs. 10 to 17 inclusive. Individual descriptions may be secured by reference to the Parts Lists, Part X, Table II. All wiring, except that integral with the units on top of the chassis, or required for their connection into the circuits, is contained below the chassis.

High Frequency Receiver—Type CAY-46077-A

3-6 The HIGH FREQUENCY RECEIVER is constructed on a chassis formed from aluminum alloy sheet bent into conventional chassis form and spot-welded at each corner. To this chassis are welded two legs at the rear and panel-supporting gussets at the front. The front panel is bolted to these gussets.

3-7 The receiver chassis is shock-mounted inside the Transportation Case in the same manner as that of the MEDIUM FREQUENCY RECEIVER. For description of this assembly, refer to Paragraph 3-4.

3-8 The arrangement of the electrical parts in the HIGH FREQUENCY RECEIVER is similar to the arrangement of parts in the MEDIUM FREQUENCY RECEIVER. The main tuning capacitor; all vacuum tubes; intermediate frequency amplifier and beat oscillator transformers; low-pass filter reactors; nine by-pass filter capacitors and the output transformer are located on top of the chassis. The antenna; R.F. and oscillator transformer assemblies; three main resistor-capacitor boards; three small resistor-capacitor boards and the remaining filter and by-pass capacitors are located below the chassis. The exact locations of the individual electrical components which comprise the receiver are shown on the photographs, Figs. 18 to 25 inclusive. Individual description may be secured by reference to the Parts List, Part X, Table II. All wiring, except that integral with, or required for connections to the units mounted on top of the chassis is contained below the chassis.

3-9 Connections to the power receptacles of the receivers are made through individual ports in the rear of the Transportation Case. These openings are sealed by watertight gaskets and port closures when the RADIO RECEIVER ASSEMBLY is prepared for transportation.

3-10 The controls and items mounted on the face of the front panel of the MEDIUM FREQUENCY RECEIVER are shown and enumerated on Fig. 10 and those for the HIGH FREQUENCY RECEIVER on Fig. 18. All controls are provided with suitable stops and/or detents as required in the operation of the receivers. The function of each control is marked on the nameplate strip across the lower portion of the panel. To simplify operation, the controls of both receivers are similarly positioned and function in a similar manner.

3-11 Referring to Figs. 10 and 18, which show the front panel of the MEDIUM FREQUENCY RECEIVER and the HIGH FREQUENCY RECEIVER respectively, the following controls are located on the front panels of both receivers. Bottom row of controls from left to right; SELECTIVITY control; GAIN control; PHONES jack; Noise Limiter

switch (directly above the PHONES jack); OUTPUT LEVEL control and RECEPTION control. The second line of controls consists of (from left to right): ANT COMP (antenna compensator control); FREQ BAND switch knob; TUNING control and BEAT NOTE control. At the left-hand edge of the panel above the two rows of controls just described are located the Antenna and Ground connectors, while slightly to the right of these is the dial light dimmer control knob. Located in the center of the upper part of the panel is the dial escutcheon which houses the dial lights. In the upper right-hand corner of the front panel is a station log. The transparent cover of the station log is lowered by operating the two thumb-screws at the top of the log. This permits making written entries.

3-12 All tubes are accessible for servicing and replacement by sliding the receiver chassis out of the Transportation Case and removing the top shield as shown in Figure 9. Sufficient space is available within the receiver with the top shield removed to permit insertion of an analyzer plug beneath the tubes without removing the side and bottom shields.

Dynamotor Assembly—Type CAY-21387-A

3-13 The DYNAMOTOR ASSEMBLY is constructed on a chassis of aluminum alloy sheet bent into a conventional chassis form and spot-welded at the four corners, as shown in Figs. 39 to 42, inclusive. The front panel is spot-welded to the chassis. Stainless steel angles are riveted to the two sides of the chassis which serve as runners when sliding the unit into its watertight transportation case.

3-14 The DYNAMOTOR ASSEMBLY case is provided with two watertight covers, one for the front and for the rear of the case. A carrying handle is provided on the top of the case. A large handle screw-driver forms the grip for the carrying handle, the screw-driver being held in place by means of a snap slide fastener. This screw-driver is used for tightening and loosening the screws of the watertight covers of the cases. The back of the case is provided with a louvred covering over the upper section. The lower portion is open to allow access to the connector receptacles. The edges of this opening are provided with gaskets which press into place against the chassis upon its insertion into the case. Adequate ventilation is provided by the louvres in the back covering of this case, as well as in the front panel.

3-15 The major electrical parts which comprise the DYNAMOTOR ASSEMBLY, and their location are as follows: The receptacles for the cables which interconnect this unit with the receivers, transmitting equipment (in a transmitting-receiving station set-up) the batteries and a C.F.I. are located on the rear skirt of the chassis as are the receptacles for the protective fuses for the equipment. A dynamotor with its shock-mounting for the MEDIUM FREQUENCY RECEIVER and a dynamotor with its shock-mounting for the HIGH FREQUENCY RECEIVER are located on top of the chassis on the left and right sides of the chassis, respectively. The dynamotors are each secured to the chassis by four snap slide fasteners and electrical connection into the circuit is made by three-prong male connectors mounted on the dynamotor shock-mount frames which engage female connectors mounted flush with the chassis. By simply operating the four snap slide fasteners, either dynamotor may be lifted vertically from the chassis for inspection or replacement without detaching any wires or other type connections.

3-16 Filter capacitors and filter reactors for the power circuits of both the M.F. and H.F. Receivers are located on top of the chassis adjacent to the dynamotor unit with which they function. The LINE VOLTS meter is mounted on shock-mounts on top of the chassis in a central position where it is viewed through a hole in the front panel. This type of mounting is necessary as the assembly as a whole is not shock-mounted and serves to protect the meter from damage due to shock or jolts while the equipment is being transported. Additional filter capacitors, R.F. reactors and a relay are located below the chassis, in addition to all wiring except that above the chassis necessary to make connections to the above-chassis components.

3-17 On the front panel are located the various control switches, rheostat, hole through which the meter is viewed and other units necessary for control of the DYNAMOTOR ASSEMBLY and power to the receivers. These items and controls are enumerated in Fig. 38.

3-18 Referring to Fig. 38, the following controls are located on the front panel of the DYNAMOTOR ASSEMBLY. Lower row of controls, from left to right: I.F. and H.F. TRANSMITTER SIDE TONE switches; MF POWER switch; MF and HF PHONE TRANSFER switch; HF POWER switch; LINE INPUT switch. At the left center is located

the dimmer control knob for the TABLE LIGHT. The TABLE LIGHT itself is located to the right of the upper center of the panel. The opening for viewing the LINE VOLTS meter is in the center of the panel.

Portable Storage Batteries—Type CES-19017

3-19 Two PORTABLE STORAGE BATTERIES of the aircraft spill-proof type are supplied with each equipment. The top and terminal box covers of these batteries are watertight and the batteries will withstand immersion. Each battery rests in a tray to which it is clamped by means of threaded hooks and wing nuts. Two webbing straps completely encircle the battery and tray. A carrying handle is attached to these straps. The terminal box is provided with two electrical connectors, each having a water-proof screw-flange and cap. These connectors provide for interconnection of the batteries to the DYNAMOTOR ASSEMBLY. All waterproof caps are secured to the battery cover or terminal box by swivel-junction chain fasteners so they cannot be lost or mislaid.

Slip Covers

3-20 Slip covers are provided for the front of the RADIO RECEIVER ASSEMBLY and for the two connection ports in the rear of the Transportation Case for protection of the equipment in a heavy rain. These are shown in position in Figs. 7 and 8. The front slip cover is provided with a flap held in place by snap fasteners which can be opened to allow operation of the various tuning controls, and two windows for viewing the tuning dials during operation with the slip cover in place.

ASSEMBLY OF THE UNITS— FIELD OPERATION

3-21 Units are assembled for field operation as shown in Figs. 3 to 8, inclusive. Three tubular metal legs are provided for elevating the RADIO RECEIVER ASSEMBLY above the ground at a convenient operating level. Attachment brackets and chains are supplied so that the cover of the Transportation Case may be fastened to the lower edge of the case to form a convenient operating table.

3-22 THE DYNAMOTOR ASSEMBLY is placed upon the RADIO RECEIVER ASSEMBLY at the left-hand side and towards the front. The two receivers and the storage batteries are connected to the DYNAMOTOR ASSEMBLY by means of plugs and cables provided with the equipment. These

interconnection cables are stowed in the Spare Parts Box when the equipment is transported. The DYNAMOTOR ASSEMBLY, in addition to performing its normal functions also serves as a "junction box" for the equipment. One Navy Type 49016 Telephone Headset is connected to the PHONES jack in each receiver. Antenna and ground connections are made to the two receivers.

BASE STATION EQUIPMENT AND ASSEMBLY

Rectifier Power Unit—Type CAY-20086

3-23 Each equipment is provided with two RECTIFIER POWER UNITS for operation at a base station where electric line current is available. THE RECTIFIER POWER UNITS are constructed on a separate zinc plated steel chassis of conventional form, spot-welded at each corner. The front panel is spot-welded to the chassis. This chassis assembly slides into a bent-up sheet aluminum alloy case. Brackets at the rear of the case restrict the motion of the heavy chassis which is otherwise entirely supported by the front panel. The POWER UNITS are suitable for placement on top, or below a base station operating table close to the receivers.

3-24 The base Station Power Supply consists of a transformer, rectifier tube and ripple filter circuit and provides filament voltage as well as correct plate voltages for operation of one receiver and one C.F.I. (Crystal Frequency Indicator).

Control Unit—Type CAY-23278

3-25 A special CONTROL UNIT is provided for operation of the receivers in conjunction with the Base Station Receiver Power Supplies. The CONTROL UNIT consists of a chassis and cover box similar to that of the RECTIFIER POWER UNIT. The CONTROL UNIT serves to interconnect the RECTIFIER POWER UNITS and the receivers. Its operating controls perform the same functions as are performed by the operating controls in the DYNAMOTOR ASSEMBLY. In addition to containing the necessary control receptacles and connector receptacles, each unit contains a special filament transformer to supply filament power to a Crystal Frequency Indicator (C.F.I.) in order to maintain it at correct operating temperature even while filament power to the receivers is turned off.

DUAL AND SINGLE BASE STATION OPERATION

3-26 When it is desired to have combined operation of the MEDIUM FREQUENCY and

HIGH FREQUENCY RECEIVERS at the base station, the CONTROL UNIT serves as a junction box for the two receivers and their two power supplies. However, by omitting the CONTROL UNIT and connecting each receiver directly to its individual RECTIFIER POWER UNIT, the receivers may be operated separately at separate parts of the base station.

MOBILE SPARE PARTS

3-27 The mobile spare parts and interconnection cables are contained in a waterproof metal box with removable cover. This is equipped with a carrying handle for easy transportation.

ELECTRICAL CIRCUITS— MEDIUM FREQUENCY RECEIVERS

3-28 For an analysis of the R.F., I.F., Oscillator and A.V.C. circuits of the MEDIUM FREQUENCY RECEIVER, in conjunction with the description which follows, refer to the Schematic Diagram, Fig. 62, Dwg. T-7611588. Circuit Symbol Numbers from 400 to 499 have been assigned to the electrical components of this receiver.

Antenna Compensation Circuit

3-29 This circuit, shown on the left-hand side of Fig. 62, Dwg. T-7611588 slightly above the horizontal center line of the drawing, consists of J401, which is indicated on the front panel as "A" the antenna terminal; C401, indicated on the front panel as ANT COMP control (Antenna Compensator Control) and C402. Through adjustment of C401, which is in parallel with fixed Capacitor C402, the receiver may be adjusted to operate efficiently with various open wire antennas. Resistor R401, across the antenna input to ground, serves to drain accumulated static charges from the antenna which might otherwise cause noisy reception and arcing within the receiver.

Antenna Input Circuit

3-30 The Antenna Input Circuit consists of the components diagramed within the dash-line enclosure indicated as T401 in the upper left-hand corner of Schematic Diagram, Fig. 62, Dwg. T-7611588 and Tuning Capacitor C412A. C412A is the section of the four-gang tuning capacitor on top of the chassis nearest the front panel. Band-Changing Switches S401A and S401B serve to connect the proper input and output circuits of T401 to give operation on the desired frequency band. Switches S401A and S401B are sections of the 7-gang band-switch which terminates as the FRE-

FREQUENCY BAND control on the front panel. This control also changes the R.F. and the Heterodyne Oscillator circuits simultaneously for operation on the band desired by the operator. Referring to T401, the components comprising the upper of the four circuits shown within the dash-line area are those of Band 4, and those below it are the components for Band 3, Band 2 and Band 1, respectively. This arrangement is carried out also in transformer assemblies T402 and T403 in order to permit identification of components in the R.F. and Oscillator circuits. For a photographic view of the components of Antenna Transformer T401, refer to Figure 26.

R.F. Amplifier Stage

3-31 The Antenna Input Stage is followed by a double-tuned single R.F. stage consisting of the components shown on Fig. 62, Dwg. T-7611588. Within the dash-line enclosures, it is indicated as T402, the Type 12SK7 first R.F. amplifier tube V401 with its associated resistors, by-pass and coupling capacitors, and tuning capacitor sections, C412B and C412C. C412B and C412C are, respectively, the second and third sections of the four-gang tuning capacitor located on top of the chassis. The various circuits are diagramed in similar positions to those indicated in T401. They are switched to the proper band for operation simultaneously with the Antenna Input Circuit and the Heterodyne Oscillator Circuit by S401C, S401D and S401E. These switches are sections of the seven-gang switch operated by the FREQUENCY BAND switch control on the front panel of the receiver.

3-32 The operation of the R.F. amplifier circuit is, briefly, as follows. Signal voltage from the antenna input circuit is fed to the grid of the Type 12SK7 R. F. Amplifier Tube V401 by Band-Changing Switch S401B through Coupling Capacitor C423 across Grid Resistor R410. C423 and R410 are located within Antenna Transformer T401. The amplified signal from the plate of V401 is tuned by Inductance L405, L406, L407, or L408, and their associated padding capacitors, depending on the frequency band in use as selected by Band-Changing Switch S401C. Switch S401D connects Tuning Capacitor C412B to the tuning circuit in use. Tuning Inductances L405, L406, L407 and L408 are each link-coupled to a corresponding tuning inductance, namely, L409, L410, L411 and L412 respectively, in the second section of the R.F. Transformer T402. When the receiver is operating on Band 1, additional intermediate frequency rejection is obtained

by the adjustable "trap" circuit L423, C418. Inductances L409, L410, L411, and L412 are tuned by C412C. The amplified signal from the output of T402 is fed to the grid of the Type 12SG7 Converter Tube, V402 through Blocking Capacitor C477 across Grid Resistor R448.

Converter Stage

3-33 The Converter Stage consists of the Type 12SG7 vacuum tube V402 and its associated resistors and by-pass capacitors. The amplified R.F. signal is fed to the grid of the tube across Grid Resistor R448 while the cathode circuit of the tube V402 is modulated by the output of the Heterodyne Oscillator across Cathode Bias Resistor R411. The oscillator frequency is maintained at all times at a point 140 Kcs. higher than the signal frequency. It combines (beats) with the signal frequency to produce an intermediate frequency at 140 Kcs. which is tuned by the primary circuit of Intermediate Frequency Transformer T404.

Heterodyne Oscillator Circuit

3-34 The Heterodyne Oscillator Circuit consists of the components within the Oscillator Transformer indicated on Fig. 62, Dwg. T-7611588 by the dash-line area T403, the Type 12SJ7 Tube V403 and its associated resistors and by-pass capacitors and Tuning Capacitor C412D. Tuning Capacitor C412D is the section of the four-gang tuning capacitor above the chassis farthest from the front panel of the receiver. These components form a tunable electron-coupled oscillator designed to provide a maximum of stability against supply voltage variation and changes in temperature and humidity.

3-35 Band-Changing Switches S401F, S401G and S401H, shown within the shielded area of T403, serve to connect the various tube and circuit elements to provide output suitable for operation on the band selected by the FREQUENCY BAND switch control on the front panel. It will be noted on the diagram that S401H is shown as if it were actually two different switch sections. Actually, it consists of one section of the complete switch assembly. The contacts are shown in different locations on the diagram to simplify the circuit arrangement. Switches S401F and S401G serve to connect the proper inductances into the circuit for the frequency band chosen by the operator. Switch S401H connects the Tuning Capacitor C412D in series with padding Capacitors C425, C426, C427 or C428. Also, by the utilization of another set of switch contacts, Switch S401H transfers the cathode of the Oscillator

Tube V403 to the cathode tap of the inductance in use. Capacitive coupling of the oscillator output to the cathode of Converter Tube V402 is provided through Coupling Capacitor C438.

Intermediate Frequency Circuits

3-36 The Intermediate Frequency Amplifier Stages consist of Intermediate Frequency Transformers T404, T405 and T406, the two Type 12SG7 Intermediate Frequency Amplifier Tubes V404 and V405 and their associated bias resistors and by-pass and coupling capacitors. The first two Intermediate Frequency Transformers, T404 and T405, are provided with two degrees of selectivity which can be chosen by the operator. Switch S402A, S402B may be adjusted by moving the SELECTIVITY control on the front panel. The SHARP position provides for operation under conditions of severe interference from directly adjacent signal channels.

Automatic Volume Control

3-37 A Type 12H6 Double Diode Vacuum Tube, V407, and associated Resistors R419, R423, R474, R473, R431, R432, R477, R445, and R475 and Capacitor C456 provide automatic volume control of the R.F. Amplifier Tube V401, Converter Tube V402, First I.F. Amplifier Tube V404 and the First Audio Amplifier Tube V409. Resistor R457 and Switch S403A (a part of gang switch terminating on the front panel at the RECEPTION control), serve to attenuate the A. V. C. action when the receiver is in the CW position. They equalize receiver gain between modulated and CW reception. Tube V407 also provides overload protection in the MOD and CW positions of the RECEPTION switch for strong input signals as the A. V. C. action is not entirely removed from the controlled tubes when the RECEPTION switch is in these positions. Only one diode section of V407 is used in the circuit. The other section is grounded and unused.

ELECTRICAL CIRCUITS—

HIGH FREQUENCY RECEIVER

3-38 The circuits described in Paragraphs 3-28 to 3-37, inclusive, for the MEDIUM FREQUENCY RECEIVER, are basically the same that form the HIGH FREQUENCY RECEIVER. (Circuit symbol Numbers 500 to 599, inclusive, have been assigned to the electrical components of the HIGH FREQUENCY RECEIVER.) The main exceptions are in the electrical constants of the tuned circuits which are applicable to the bands covered by the H.F. Receiver, and the electrical constants of the

Heterodyne Oscillator and the I.F. Amplifier circuits which are such as to provide an intermediate frequency of 1255 Kcs. Reference to Fig. 63, Dwg. T-7611586 will show the following additional minor circuit differences. ANT COMP CONTROL (Antenna Compensation Capacitor) C501 is located across the secondary of Antenna Transformer T501 instead of in series with the Antenna and the primary of the corresponding transformer T401 in the MEDIUM FREQUENCY RECEIVER. Another difference is found in the tubes controlled by the A. V. C. In the HIGH FREQUENCY RECEIVER, these are the R.F. Amplifier Tube V501; the first Intermediate Amplifier Tube V504 and the first Audio Amplifier Tube V509. The Converter Tube V502 is not controlled by A. V. C. in the HIGH FREQUENCY RECEIVER. Voltage supplied to the A. V. C. tube is derived from the "high" side of the secondary of the intermediate frequency output transformer instead of from a tap on the primary as in the MEDIUM FREQUENCY RECEIVER. Also, no additional attenuation at the intermediate frequency is used in the HIGH FREQUENCY RECEIVER since the preselector provides sufficient attenuation for this frequency.

CIRCUITS COMMON TO THE M.F. AND H.F. RECEIVERS

Beat Frequency Oscillator Circuit

3-39 The Beat Frequency Oscillator Circuits of both the M.F. and H.F. Receivers are nearly similar. The exceptions are the values of the frequency-determining components. In each case, they are designed to provide a beat frequency signal of the proper value to operate with the intermediate frequency channels with which they are associated. This circuit consists of the Type 12SJ7 tube V408 (V508) which is connected as a tetrode, the Tuned Circuit L420 (L520) and Capacitors C471 (C571) and C472 (C572). Capacitor C473 (C573) provides for a small change in the beat note frequency. The control of this capacitor is brought out to the front panel of the receivers where it terminates in the BEAT NOTE control. The oscillator circuit is of the electron-coupled type. Output is coupled to the second detector of the receivers through Capacitors C467 (C567 and C556).

Second Detector Circuit

3-40 The second detector of both receivers is the Type 12H6 Dual Diode Vacuum Tube V406 (V506). One section is used for the detector circuit with associated Resistors R426 (R526) and R427

(R527) and Capacitors C454 (C554) and C455 (C555). A terminal J404 (J504) is provided on the rear of each receiver, the terminals normally being connected together by a jumper. The removal of this jumper permits the insertion of a microammeter into the diode detector circuit for purposes of aligning the receivers. The second section of the Type 12H6 Tube V406 (V506) serves as a noise peak limiter, in conjunction with its associated Resistors R428 (R528) and R449 (R549) and Capacitor C461 (C561). In the diagrams, Figs. 62 and 63, Dwg. T-7611588 and T-7611586, respectively, the Noise Limiter Switch S404 (S504) is shown in the OFF position with the noise limiter circuit inoperative. This switch is the NOISE LIMITER switch on the front panel directly above the PHONE jack. In the ON position of Switch S404 (S504) the audio signals pass through the first section of V406 (V506). When sharp pulses of noise are combined with the signal, sufficient bias is developed across Resistor R426 (R526) to make the diode non-conducting. This prevents the noise pulse from reaching the audio circuits.

First Audio Stage

3-41 The first audio stage is comprised of the Type 12SK7 Tube V409 (V509) and its associated Capacitors and Resistors C476 (C576), R471 (R571), C450A (C550A), C450B (C550B), R430 (R530), R403 (R503), and C482 (C582). The plate circuit of V409 (V509) contains a low-pass filter consisting of Reactive elements L421 (L521), L422 (L522) and Capacitors C462 (C562), C464 (C564), and C465 (C565). This filter offers high attenuation to all audio frequencies above 3500 cycles.

Second Audio Stage

3-42 The second audio amplifier circuit is comprised of the Type 12SJ7 vacuum tube V410 (V510) and its associated components. Switch S403 (S503) provides output limiting when in its clockwise position (RECEPTION control in the OL position) and when the OUTPUT LEVEL Potentiometer R433A (R533A) is retarded. The inverse feedback circuit, consisting of R467 (R567) and C462 (C562) between vacuum tubes V411 and (V511) and V410 (V510) provides good regulation of the receiver output when switching from one to two sets of headphones, or vice versa.

Audio Output Stage

3-43 The audio output stage consists of a Type 12A6 vacuum tube V411 (V511) and associated components. Output of this stage is coupled through Transformer T508, isolating D.C. from the secondary, or phone circuit.

ELECTRICAL CIRCUITS— POWER AND CONTROL EQUIPMENT

Dynamotor Assembly

3-44 Schematic Diagram, Fig. 64, Dwg. P-7711543, shows the components of the DYNAMOTOR ASSEMBLY. Circuit symbol numbers from 600 to 699, inclusive, have been assigned to the electrical components of this unit. The input and output circuits of Dynamotor D601 which provides high voltage to the MEDIUM FREQUENCY RECEIVER are filtered by Capacitors C605 and C606 and Reactors L603 and L604. Capacitors C602 and C603 are inside the "end bell" housings of the dynamotors. Dynamotor D602, which provides high voltage for the HIGH FREQUENCY RECEIVER, is filtered by Capacitors C601 and C604 and Reactors L601 and L602. Receptacle J605 receives the cable plug of the connector which provides voltages to the Crystal Frequency Indicator (C.F.I.). Relay K601 switches the high voltage lead from Connector J605 to whichever dynamotor is in operation. When both the dynamotors supplying the MEDIUM FREQUENCY and the HIGH FREQUENCY RECEIVER are in operation, the Crystal Frequency Indicator derives its high voltage supply from the dynamotor normally supplying high voltages to the MEDIUM FREQUENCY RECEIVER. The DYNAMOTOR ASSEMBLY contains control units used in the operation of the receivers. The I.F. and H.F. SIDE TONE Switches, S604 and S605, apply or disconnect the side tone from the transmitters to the corresponding receivers. The MF-HF PHONE TRANSFER Switch S603A, S603B is a four-position, two section switch which provides various connections of the headsets of the two receivers as described in Paragraph 5-19. S606 is the LINE INPUT switch which controls the power from the batteries. LINE VOLTS meter M601 is across the battery input and indicates the voltage supplied by the batteries. Switch S601A, S601B is the M.F. Receiver power switch, while S602A, S602B is the H.F. Receiver power switch. R601 is the Table Light dimmer rheostat. The receptacles on the back are as follows: J601,

I.F. Side Tone Receptacle; J602, H.F. Side Tone Receptacle; J605, C.F.I. Power Receptacle; J606, H.F. Receiver Power Receptacle; J607, M.F. Power Receptacle; J608, Battery Connector Receptacle and J609, Receptacle for battery charging connection.

Rectifier Power Units

3-45 The circuit and components of the Rectifier Power Unit are shown by Fig. 65, Dwg. P-7711545. This circuit consists of a conventional full-wave high voltage rectifier circuit with a choke input filter system. The filter circuit is terminated by a bleeder resistor to aid in stabilizing the voltage output against changes in the line voltage. Both

sides of the primary circuit are fused for protection of the unit.

Control Units

3-46 The circuit and components of the Control Unit for base station operation are shown by Fig. 66, Dwg. P-7711544. When this unit is connected to the A.C. power line and Switch S1006 is closed, Transformer T-1001 supplies filament voltage to the Crystal Frequency Oscillator Receptacle J1008. As a result, the C.F.I. can be kept warmed up for operation even though power to both Rectifier power supplies is turned off. Suitable line fuses protect T1001 and K1001.

IV. Installation

SETTING UP THE EQUIPMENT

4-1 Due to the portable nature of the Navy Model RBM-5, Semi-portable Radio Receiving Equipment, it is not anticipated that the equipment will, in general practice, become part of a permanent installation at a fixed location. Consequently, the scope of the installation data in this instruction book will be limited to the procedures involved in setting up the equipment for portable service in the field. The text will also deal with temporary service at base stations where power line current of the proper type is available to permit the use of the auxiliary power units supplied with the equipment.

Field Service (With Navy Model TBW-5, Transmitting Equipments)

4-2 Where the equipments are to be used as part of a portable Transmitting-Receiving station in conjunction with transmitting equipment of the Model TBW series, the general arrangement and location of the various components of the entire station, including the receiving equipment are shown in the instruction book which is part of the Model TBW series equipment. It is usually best to set up the transmitting antenna installation and locate, from it, the transmitting and receiving positions before commencing to unpack and set up the receiving equipment. After the transmitting antenna has been located, both the transmitting and receiving equipments should be placed approximately where they will be located. The Model RBM series receiving equipments are set up in the following manner.

- (1) Remove the legs and leg guy chains from the Accessory Bag.
- (2) Turn the RADIO RECEIVER ASSEMBLY with its top on the ground and fit one leg into each of the leg brackets (one on each side and one on the back) of the unit, placing the leg without chains in the rear bracket.
- (3) Fasten the leg guy chains as indicated on Fig. 49, Dwg. T-7613094 and the photographs, Figs. 4 to 6 inclusive.
- (4) Two men should then grasp the entire assembly, lift it and turn it right side up, setting it on its legs in the position selected.

- (5) Loosen the tightening screws in the cover of the case and remove the cover. Remove the chain supports and brackets from the Accessory Bag, for connecting the top of the case as an operating table. Assemble the top of the case to the case by screwing one bracket into the last tightening screw hole on the right and on the left sides of the flange on the bottom of the case. Attach one of the guy chain clamps to the screw farthest forward on the right and left-hand side of the top. Place the top in position and screw one screw into each of the clamps which are mounted on the case and assemble the chains as shown on Fig. 49, Dwg. T-7613094 and photographs, Figs. 3 to 6 inclusive.
- (6) Remove the watertight covers from the front and back of the DYNAMOTOR ASSEMBLY case. Place the case on top of the RADIO RECEIVER ASSEMBLY, locating it to the left side of the receiver case with the front flush with the front of the receiver case.
- (7) Place the C.F.I. (Crystal Frequency Indicator) on the right-hand side of the top of the case in a position roughly corresponding to the position of the DYNAMOTOR ASSEMBLY on the right-hand side.
- (8) Place the PORTABLE STORAGE BATTERIES beneath the receiver unit (to prevent rain from getting into the ventilation port when the plug has been removed) in the approximate positions indicated in Figs. 3 to 6 inclusive. Remove the ventilation plug from the top of each battery.
- (9) Unpack the interconnection cables from the Mobile Spare Parts Box and assemble as shown on Fig. 68, Dwg. P-7713096 and as described below.
- (10) The H.F. and I.F. SIDE TONE CABLES (carried in the Spare Parts Box of the transmitting equipment) should be plugged into the proper jacks on the DYNAMOTOR ASSEMBLY. The antenna connection from the INTERMEDIATE

FREQUENCY TRANSMITTER should be connected to the "A" (antenna) terminal of the MEDIUM FREQUENCY RECEIVER.

- (11) Connect Cable W1801 from connector marked P1809 on the back of the DYNAMOTOR ASSEMBLY to connector marked P703 on the Type CDO-73004-B Gasoline Driven Portable Generator, a part of the Model TBW Series Radio Transmitting Equipment.
 - (12) Connect Cable W1601 from connector marked P1605 to connector marked P1601 on the Portable Storage Battery and connect Cable W1701 from connector marked P1702 on this same battery to connector marked P1701 on the second storage battery.
 - (13) Connect Cable W1401 from connector marked P1407 on the DYNAMOTOR ASSEMBLY to connector marked P1405 on the back of the MEDIUM FREQUENCY RECEIVER through the connection port in the back of the case.
 - (14) Connect Cable W1501 from connector marked P1506 on the DYNAMOTOR ASSEMBLY to connector marked P1505 on the back of the HIGH FREQUENCY RECEIVER.
 - (15) Connect C.F.I. Cable from connector marked C.F.I. on the DYNAMOTOR UNIT to the Crystal Frequency Indicator Connector.
 - (16) Plug one set of Navy Type 49016 Telephone Headsets into the PHONES jack on the MEDIUM FREQUENCY RECEIVER and one set of Navy Type 49016 Telephone Headsets into the PHONES jack on the HIGH FREQUENCY RECEIVER.
- (4) Remove the chains and clamps used to hold the cover of the Transportation Case while it is being used as an operating table, and stow them in the Accessory Bag.
 - (5) Place the cover on the Transportation Case and set up the tightening screws to assure a watertight seal at the gasket.
 - (6) Replace the watertight port closures in position over the two cable connection ports in the back of the Transportation Case and set them up tightly.
 - (7) Place the two watertight covers on the connectors in each storage battery and replace the ventilation plug in the top of each battery.
 - (8) Turn the entire RADIO RECEIVER ASSEMBLY upside down on the ground with the legs projecting upward. Remove the guy chains and the legs and stow them in the Accessory Bag.

The equipment is now ready for transportation.

Field Service, Receiving (Only) Installation

4-4 The operations required to set up the equipment for field operation in connection with a Model TBW series Radio Transmitting Equipment and to set up the equipment for independent operation as a receiving station are, in general, similar. The erection of an antenna or antennas for the receivers is the only additional operation not described in Paragraph 4-2. Antenna wire for the required antennas is not supplied as part of this equipment. Consequently, the erection of the antenna is not discussed in this instruction book. The connections from the antennas used should be made direct to antenna terminals "A" of the receivers. All interconnections between the units are made in the same manner described in Paragraph 4-2, except that the side tone cables from the transmitters to the DYNAMOTOR ASSEMBLY and the cable from the gasoline driven generator to the DYNAMOTOR ASSEMBLY are omitted. The connectors normally used for attachment of these cables to the DYNAMOTOR ASSEMBLY are unused, no other connection to them being required.

Base Station Operation (From Power Supply Lines)

4-5 Each equipment includes two RECTIFIER POWER UNITS and one CONTROL UNIT for operation at base stations where 115 volt, single phase, 60 cycle line power is available. The DYNAMOTOR ASSEMBLY and the storage batteries are not used in this type of operation and may be stowed.

The equipment is now ready for operation in conjunction with the Model TBW series Radio Transmitting Equipment with which it is associated. (Refer to Part V Operation.)

Packing the Equipment for Transportation

4-3 To pack the equipment for transportation, the following procedure is recommended:

- (1) Remove all interconnection cables and stow them in the Spare Parts Boxes. Remove the Navy Type 49016 Telephone Headsets and stow them in the compartment in the spare parts box provided for them.
- (2) Disconnect the C.F.I. and prepare for transportation.
- (3) Place the watertight covers on the front and back of the DYNAMOTOR ASSEMBLY and tighten the screws securely to be certain of a watertight seal at the gasketed conjunctions.

For Dual Operation (A.C. Supplies)

- (1) Dual operation is defined as that type of operation in which the receivers are both used in one operating position in the base station, in close proximity to permit the interconnection of both the H.F. and M.F. Receivers for operation with a single CONTROL UNIT. When dual operation of the two receivers is desired at a base station or other point where suitable power supply voltage is available, the receivers may be operated either in the Transportation Case, or removed from the case and arranged individually in the operating position.
 - (2) The units required for dual operation (the receivers, either located within their Transportation Case or removed from it, the two RECTIFIER POWER UNITS and the CONTROL UNIT) are arranged on the operating table with the M.F. Receiver at the left, the CONTROL UNIT and C.F.I. in the center and the H.F. Receiver at the right to permit an orderly assembly of the cables. The RECTIFIER POWER UNITS may be placed on a shelf or under the table, if more convenient.
 - (3) Interconnection of the units should be made as follows, referring to Fig. 69, Dwg. P-7713095.
 - (a) Connect Cable W1401 from the power receptacle on the M.F. Receiver marked P1405 to the receptacle marked P1407 on the CONTROL UNIT.
 - (b) Connect a Navy DCP-1 cord (not supplied as part of the equipment) from the male connector on one RECTIFIER POWER UNIT to the female A.C. connector on the CONTROL UNIT located adjacent to the connector marked P1407.
 - (c) Connect Cable W1901 from connector marked P1903 on this RECTIFIER POWER UNIT to the connector marked P1907 on the CONTROL UNIT.
 - (d) Connect one Navy DCP-1 cord from the male A.C. connector in the center of the group of connectors on the back of the CONTROL UNIT. After all other connections have been completed, the plug on the other end of this cord is connected to the A.C. supply lines of the base station to provide all power required for operation of the set-up.
 - (e) Connect one Navy DCP-1 cord from the female A.C. connector on the right of the male A.C. connector used for the power line cable to the male A.C. connector plug on the other RECTIFIER POWER UNIT.
 - (f) Connect Cable W2001 from the connector marked P2009 on the CONTROL UNIT to the connector marked P2003 on this RECTIFIER POWER UNIT.
 - (g) Connect Cable W1501 from the connector marked P1506 on the CONTROL UNIT to the power receptacle on the H.F. Receiver.
 - (h) Connect the C.F.I. Cable from the receptacle on the CONTROL UNIT marked "C.F.I." to the C.F.I. unit to be used with the equipment.
 - (i) Connect the side tone cables from the transmitters to the SIDE TONE jacks on the CONTROL UNIT. The side tone cable from the intermediate frequency transmitter is connected to the jack indicated as I.F. SIDE TONE and the cable from the high frequency receiver to the jack indicated as H.F. SIDE TONE on the CONTROL UNIT.
 - (j) Connect antenna leads to "A" and ground lead to "G" terminals. NOTE: Before operation is undertaken, refer to Paragraph 5-46 for instructions for adjusting the DUAL-SINGLE control in the RECTIFIER POWER UNITS.
- (4) To disassemble the equipment as set up for base station dual operation, follow the instructions given in Paragraph 4-5 (1) to (3) inclusive in reverse order.

For Single Operation (A.C. Supplies)

- (1) When it is desired to operate the receivers in positions so separated that Dual Operation is not feasible due to the length of the connections or the impracticability of operating both receivers from a single CONTROL UNIT, the receivers may be set up for Single Operation in the following manner. One RECTIFIER POWER UNIT and one receiver are necessary at each point of operation. See Fig. 70, Drawing P-7713094.
 - (a) Place each receiver in its operating position after removing it from the Transportation Case. (One receiver may be removed from the case and one operated in the case, if desired.)
 - (b) Locate one RECTIFIER POWER UNIT adjacent to each receiver where its control

- switch may be operated from the operating position.
- (c) Connect Cord W1401 from the power receptacle of the M.F. Receiver to the connector marked P1903 on the RECTIFIER POWER UNIT. Connect a Navy DCP-1 cord from the male A.C. connector of the RECTIFIER POWER UNIT to the supply line connector.
 - (d) Connect Cord W1501 from the power receptacle of the H.F. Receiver to the connector marked P2003 on the RECTIFIER POWER UNIT. Connect a Navy DCP-1 cord from the male A.C. connector of the RECTIFIER POWER UNIT to the supply line connector.
 - (e) C.F.I. (Crystal Frequency Indicators) may be connected in both operating positions, or in either position, whichever is desired. The C.F.I. cable is connected to the center connector of the RECTIFIER POWER UNIT in the operating position at which it is used.
 - (f) Connect antennas to "A" and ground to "G" terminals. NOTE: Before operation is undertaken, refer to Paragraph 5-48 for instructions for adjusting the DUAL-SINGLE control in the RECTIFIER POWER UNITS.

Repacking the Equipment after Base Station Operation

4-6 After Base Station Single or Dual Operation, the equipment is stowed as follows:

- (1) Replace the receivers in the watertight Transportation Case. Place the front cover in position and tighten all tightening screws to assure a watertight seal. The port covers should be placed on the ports on the back of the case and made secure. Replace the cables belonging to the equipment in the Mobile Spare Parts Box and stow the A.C. cables which are not part of the equipment according to stowage instructions at the Base Station.
- (2) The RECTIFIER POWER UNITS and the CONTROL UNIT, may be stowed according to base station stowage arrangements.

V. Operation

GENERAL

5-1 Before attempting operation of the Navy Model RBM-5, Semi-Portable Radio Receiving Equipment the operator should thoroughly familiarize himself with the functions and uses of the various controls on the different units of the equipment. When referring to the controls in this description the words in capital letters represent the part of the name on the nameplate adjacent to the control. For example, when referring to the "SELECTIVITY control" the word "SELECTIVITY" in capitals indicates the legend appearing adjacent to the control on the receivers. Reference to photographs, Figs. 10 and 18 is suggested while reading this description.

CONTROLS (M.F. AND H.F. RECEIVERS)

5-2 The controls on the MEDIUM FREQUENCY RECEIVER and on the HIGH FREQUENCY RECEIVER are identical and perform the same function on both receivers. Therefore one description will serve for both receivers.

Selectivity Control

5-3 The SELECTIVITY control is a two-position switch which allows selection of BROAD or SHARP selectivity by controlling the degree of coupling in two stages of the intermediate frequency amplifier circuits of the receivers.

Gain Control

5-4 The GAIN control consists of a potentiometer which controls the voltage to the cathode of the R.F. and I.F. amplifier tubes, thereby controlling the overall gain of the receivers. This control is operative in all positions of the RECEPTION switch.

Phones Jack

5-5 The PHONES jack is a single circuit jack operating with the sleeve side grounded and is suitable to receive the plug of a Navy Type 49016 Telephone Headset. Its circuit connection is controlled by the PHONE TRANSFER switch on the DYNAMOTOR ASSEMBLY or the CONTROL UNIT as will be described later. (See Paragraph 5-19).

Noise Limiter Control

5-6 The NOISE LIMITER control consists of a single-pole double-throw switch which switches the noise peak limiter in and out of the circuit. The NOISE LIMITER is switched ON under conditions where sharp peak interference, such as caused by atmospheric static, key clicks and other intermittent electrical disturbances, is encountered. This control is operative for all positions of the RECEPTION control.

Output Level Control

5-7 The OUTPUT LEVEL control consists of a dual potentiometer. The front section of this potentiometer controls the plate and screen voltage of the output limiter tube while the rear section controls the signal input to the audio frequency amplifier. The front section of this control is operative only when the RECEPTION control is in the OL position. The rear section of the potentiometer is operative during all positions of the RECEPTION control except in the OL position. In either case this control serves to adjust the output volume of the receiver as delivered at the PHONES jack.

Reception Control

5-8 The RECEPTION control consists of a two-section four-position wafer type switch. In AVC position, the switch establishes circuits in the receivers so that automatic volume control potentials are applied to all controlled tubes. This setting of the RECEPTION control is normally used for voice modulated reception. Under conditions of wide variation in the signal input, the AVC position of the RECEPTION control will maintain a substantially constant output from the receivers. The MOD position of the RECEPTION control may be used for either voice modulated or tone modulated (M.C.W.) reception. In this position of the RECEPTION switch, automatic volume control is not applied to the R.F. and I.F. amplifier tubes. The CW position of the RECEPTION switch applies high voltage to the Beat Frequency Oscillator permitting reception of C.W. signals. In the OL position, the Beat Frequency Oscillator remains operative for reception of

C.W. signals and the OUTPUT LEVEL control becomes operative to control the output limiter tube. This type of reception (with the control in the OL position) may be used to protect the operator's ears against strong signals due to nearby transmitters, or against excess audio output on peaks when there is a wide variation in the strength of the received signal.

Antenna Compensation Control

5-9 The ANT COMP control (Antenna Compensation Control) adjusts a variable air type capacitor in the receivers' input circuits. It permits alignment of the input circuit for use with antennas of from 80 to 500 micro-microfarads capacity. This control is adjusted at one point near the high frequency end of each band for the antenna in use and needs no further adjustment when tuning to other frequencies within that band.

Frequency Band Control

5-10 Operation of the FREQ BAND control (Frequency Band Control) permits selection of the correct frequency band. The lettering of the tuning dial masking plates indicates the band on which the receivers are prepared to operate as a result of operation of this control. Through a 7-gang wafer-type switch, the operation of this control selects the circuit components required for operating on the band desired.

Tuning Control

5-11 Operation of the TUNING control knob rotates the main tuning capacitor as well as the main and vernier tuning dials. Ten complete revolutions of this control knob are required to cover each frequency band. Spring split gears in the tuning mechanism provide for tuning with less than 1/2 vernier dial division of backlash. Sturdy stops are provided at each end of the tuning dial which operate directly on the tuning knob shaft. This prevents straining the tuning gears and mechanism at any place in the tuning operation.

Beat Note Control

5-12 The BEAT NOTE control is coupled to a small variable capacitor by means of a dental type flexible shaft. This permits the variable capacitor to be located close to the other components of the Beat Frequency Oscillator. The Beat Frequency Oscillator is so adjusted that a beat note of 1000 cycles will be heard in the output of the receiver when the pointer of the knob is set to zero and a signal is centered in the acceptance band of the receiver.

Complete rotation of the BEAT NOTE control will cause 1500 to 3000 cycles variation of the beat note in output of the MEDIUM FREQUENCY RECEIVER and approximately 2500 to 5000 cycles variation of the beat note in the output of the HIGH FREQUENCY RECEIVER.

Dial Light Dimmer Control

5-13 This control consists of a rheostat in series with the two dial lights which are connected in parallel. This circuit is connected across the filament circuit of the receivers. When this control is rotated fully clockwise the dial lights are at their brightest. Rotation of this control from a full clockwise position serves to dim the dial lights gradually until they are completely extinguished at the full counter-clockwise position.

Station Log

5-14 The station log consists of a set of ten 2-ply bristol board sheets. These sheets are divided into four columns which permit the recording of station information including frequency, band and dial settings. This data is recorded in the four columns provided, namely; Station, Frequency, Band and Dial. The cover for the log is hinged at the bottom and secured by two thumb screws at the top. When the thumb screws are released, the cover is lowered, permitting access to the bristol board sheets for recording of station information.

Tuning Dial

5-15 The main and vernier tuning dials are visible through the dial escutcheon which encloses the two dial lights. The direct frequency calibration figures for the band in use are seen through a slot in the masking plate while the vernier and its counter on the outside of the main tuning dial are visible at all times regardless of the frequency band to which the receiver is adjusted.

CONTROLS (DYNAMOTOR ASSEMBLY)

Intermediate Frequency Transmitter

Side Tone Switch

5-16 The IF TRANS SIDE TONE switch is a single-pole, single-throw switch which serves, in the ON position to connect the side tone output of the I.F. transmitter to the headphone circuit of the MEDIUM FREQUENCY RECEIVER. It permits the operator to hear the side tone of the I.F. transmitter in his headphones.

**High Frequency Transmitter
Side Tone Switch**

5-17 The HF TRANS SIDE TONE switch is a single-pole, single-throw switch which serves, in the ON position, to connect the side tone output of the H.F. transmitter to the headphone circuit of the HIGH FREQUENCY RECEIVER. It permits the operator to hear the side tone of the H.F. transmitter in his headphones.

Medium Frequency Receiver Power Switch

5-18 The MF POWER switch consists of a rotary three-position, two-section toggle switch. In the counterclockwise, or OFF position, both sections of the switch are open and neither filament power nor plate power is supplied to the M.F. Receiver. In the FIL ON position, one section of the switch applies power to the filaments of the tubes, placing the receiver in "stand-by" condition. In the PLATE ON position, the second section of the switch applies power to the M.F. receiver DYNAMOTOR which, in turn, supplies plate power to the M.F. Receiver. Maintaining the receiver in "stand-by" condition, whenever possible, results in a considerable saving in battery current.

M.F. and H.F. Phone Transfer Control

5-19 The PHONE TRANSFER switch consists of a two-section, four-position wafer-type switch. When set to SEPARATE, the headphones of each receiver are connected to the output circuit of that receiver only. When set to ON MF both headphone sets are connected to receive the output of the M.F. Receiver only. Similarly in the ON HF position, both pairs of headphones are connected to the output of the H.F. Receiver only. While in the MIXED position, both pairs of headphones receive signals from both receivers. This control enables one operator to monitor the output of both receivers, or for two operators to each receive the output of one receiver separately, or to listen to both receiver outputs simultaneously.

High Frequency Receiver Power Switch

5-20 The HF POWER switch performs the same functions for the H.F. Receiver as the MF POWER switch performs for the M.F. Receiver. These functions and methods of operation are described in Paragraph 5-18.

Line Input Switch

5-21 The LINE INPUT switch controls all power input to the DYNAMOTOR ASSEMBLY. When the switch is in the OFF position, no power is applied to the MF or HF POWER switches or to the C.F.I. receptacle. In the ON position, low potential power is applied to the MF POWER and HF POWER switches permitting them to control the circuits for which they are intended. Voltage is also supplied to the LINE VOLTS meter while this switch is in the ON position.

Table Light Dimmer Control

5-22 The table light dimmer control consists of a rheostat in series with the table light bulb. When in a clockwise position, full voltage is applied to the table light bulb and the light is at maximum. As this control is rotated counter-clockwise it reduces the voltage applied to the bulb causing it to dim gradually until at the full counterclockwise position, the bulb is entirely extinguished.

Table Light

5-23 The table light is constructed so that, when the DYNAMOTOR ASSEMBLY is in the recommended position on the RECEIVER UNIT, and the lamp housing is pulled outward approximately 2 inches, it will shine down on the receiver operating table as well as give general illumination to the receiver controls. A rotatable lamp shield over this lamp permits the light to be directed to one side or the other of the operating table. When the DYNAMOTOR ASSEMBLY is packed for transportation the table light is pushed back into the panel as far as it will go.

Line Voltmeter

5-24 The 15 volt full-scale LINE VOLTS meter is connected so that when the LINE INPUT switch is thrown to the ON position, the battery voltage at the DYNAMOTOR ASSEMBLY will be indicated. Observation of this meter will indicate the general condition of the PORTABLE STORAGE BATTERIES when the voltage indicated is read with the receiving equipment drawing current from the line.

OPERATING ADJUSTMENTS

5-25 WARNING: REMOVE THE PLUG FROM THE TOP COVER OF EACH STORAGE BATTERY BEFORE PUTTING THE EQUIPMENT INTO OPERATION AND BEFORE PLACING THE BATTERIES ON CHARGE.

To Start and Stop the Equipment

5-26 Assuming the equipment to be set up for field operation as described in Part IV Installation, remove the plug from the top cover of each storage battery, adjust LINE INPUT switch to ON position. Adjust the MF and HF POWER switches to the PLATE ON positions. Observe the LINE VOLTS meter. If the voltage indicated is less than 10.5 volts, the batteries require charging. See Paragraphs 6-7 for instructions for charging the storage batteries. Operate the PHONE TRANSFER switch to provide output from the receiver. Plug a pair of Navy Type 49016 Telephone Headsets into the PHONES jack on each receiver. The receivers are now ready for tuning. To stop the equipment, adjust the MF and HF POWER switches to the OFF position and adjust the LINE POWER switch to the OFF position.

Preliminary Tuning Adjustments (General)

5-27 Rotate the OUTPUT LEVEL control fully clockwise to 100 and rotate the GAIN control until the noise level is faintly audible. Rotate the FREQ BAND control until the desired frequency band is indicated on the dial masking plate. Tune to the high frequency end of this band, to the highest frequency indicated on the masking plate, and adjust the ANT COMP control to give maximum noise level in the headphones. Depending upon the type of signal desired, proceed in accordance with the instructions contained in the following paragraphs.

C.W. Signal—Preliminary Tuning Adjustments

5-28 Set the RECEPTION switch to the CW position, switch the SELECTIVITY control to SHARP and the BEAT NOTE control to zero. Adjust the TUNING control until the desired signal approaches zero beat. From the zero beat tuning position adjust the tuning control towards the lower indicated dial frequencies until the strongest headphone signal is reached. When the headphone signal is approximately 1000 cycles, the dial frequency indication will be within 1% of the received frequency. Set the OUTPUT LEVEL to 100 and adjust the volume of the headphone signal by means of GAIN control.

C.W. Signal—Optimum Tuning Adjustments

5-29 In a majority of situations the procedure outlined in Paragraph 5-28 will be all that is required for satisfactory reception of a C.W. signal.

However, when unfavorable interference conditions exist, the following additional adjustments will, under most conditions, result in improvement in reception.

5-30 To tune in a weak signal with a strong interfering signal separated from it about 1 or 2 kcs. the following procedure should be followed. Since the desired signal is relatively weak it will be necessary to keep the GAIN control advanced to somewhere in the neighborhood of 80 to 90. The *interfering* signal then may be tuned to zero beat either by adjusting the tuning control or by adjusting the beat note control or by a combination of both of these controls. Under such conditions it may not be possible to secure exactly a 1000 cycle beat note from the desired signal. However, this procedure may enable a signal to be copied which might otherwise be unreadable. By adjusting the BEAT NOTE control it may be possible to gain additional selectivity by tuning slightly to the side of the peak of the selectivity characteristics of the receiver. If any "key clicks" are present due to the strong interfering signal, they may be minimized by switching the NOISE LIMITER to the ON position. With this condition of operation for the M.F. Receiver, an approach to single side-band reception may be had by operating with the SELECTIVITY control in the SHARP position. Thus, reception can be effected on either side of the zero beat position. It is possible to depart from the normal tuning procedure and tune the receiver toward the higher frequency end of the band from zero beat and often avoid an interfering signal located on the low frequency side of the desired signal. However, this procedure will result in some loss of gain in the output of the receiver.

5-31 The same condition described in Paragraph 5-30 may be handled by another set of adjustments. Adjust the controls as described in Paragraph 5-30 with the exception that the RECEPTION control is switched to the OL position. Retard the OUTPUT LEVEL control until the interfering signal is at a comfortable level. These adjustments do not change the gain level of the receiver with respect to the desired signal. Only the output resulting from the interfering signal has been changed. This means that the weaker signal may be heard if the tuning of the receiver is correct for its frequency. Adjustment of the TUNING control and/or the BEAT NOTE control will make the beat note of the desired signal come at the best response in the headphones. In this manner the receiver characteristics offer the best discrimination between the desired and undesired signal.

5-32 If the desired signal is moderately strong, and separated from 1 to 2 kcs. from a strong, undesired signal, the following procedure may be used. Leave SELECTIVITY in the SHARP position, adjust the GAIN control to 80 or 90, set RECEPTION control at CW and the OUTPUT LEVEL adjusted to a comfortable headphone level. Tuning is effected as outlined in Paragraphs 5-30 and 5-31 to secure a beat note giving best response in the headphones. The advantage of this method lies in the fact that the excitation from the B.F.O. will limit the strong signal with considerably less audio frequency harmonic distortion than is produced when the output limiter (OL) is used.

M.C.W. Signal—Preliminary Tuning Adjustments

5-33 Set the RECEPTION switch to the MOD position. Switch the SELECTIVITY control to SHARP. Set the OUTPUT LEVEL to 100 and adjust the GAIN control to give an audible noise level in the headphones. Switch the FREQ BAND control to the desired band and tune the desired signal to maximum output in the headphones. Adjust GAIN control to give the desired headphone level for copying.

M.C.W. Signal—Optimum Tuning Adjustments

5-34 Under certain conditions, especially those encountered when heavy atmospheric (static) conditions exist, it is sometimes difficult for the operator to separate the audio component of the M.C.W. signal from the noise caused by electrical disturbances, when both are present in the output of the receiver. Under such conditions, better reception can sometimes be secured when the receivers are operated as for a C.W. Signal (refer Paragraphs 5-28 to 5-32 inclusive) and tuned for a beat frequency with the carrier wave of the desired signal. Where consistent with operating regulations, the receiving operator of a transmitter-receiver installation may request the operator of the other station to change the type of his emission to C.W. in order to effect more satisfactory receiving conditions.

5-35 Where interference is caused by the presence of another and stronger M.C.W. signal on an adjacent channel to the desired signal, this interference condition can sometimes be minimized by tuning to the side of the desired signal opposite that of the interfering signal. This procedure will attenuate both signals, but will attenuate the undesired signal to a greater degree than the desired signal. The desired signal may be brought up to a satisfactory

output level in the headphones by adjusting the GAIN control.

5-36 Interference of the type discussed in Paragraph 5-35 may also be minimized by adjusting the receiver for C.W. reception, and utilizing only the intermittent carrier wave of the transmitting station to provide a beat note in the receiver. The operator may then tune for the signal as described in Paragraphs 5-29 to 5-32 inclusive.

Voice Modulated Signal—

Preliminary Tuning Adjustments

5-37 For normal reception of voice modulated (radiophone) signals it is generally desirable to operate the receivers with the RECEPTION control in the AVC position and the SELECTIVITY control in the SHARP position. The operation of the RECEPTION control in the AVC position maintains the signal in the headphones at a substantially constant level despite wide fluctuations of signal strength at the input of the receivers. This minimizes the effects of signal fading and prevents sudden "blasts" of sound in the headphones when strong stations are tuned in or are passed during the operation of the TUNING control from one frequency to another. When using the RECEPTION control in AVC position, the GAIN control should be maintained at approximately 85 and the headphone level adjusted by means of the OUTPUT LEVEL control. This method of operation maintains the R.F. and I.F. amplifiers in a condition in which they are capable of high gain (amplification) of the received signal. It assists in the location of weak signals by the TUNING control. It also permits the AVC to function over a sufficient range of signal input to maintain the output in the headphones at the desired level even at the point in the fading when the signal is weakest. After the signal has been tuned in, the SELECTIVITY control may be switched to BROAD to improve the signal quality.

Voice Modulated Signal—

Optimum Tuning Adjustments

5-38 Interference caused by an undesired signal of any type on an adjacent channel to a voice-modulated signal will cause a beat frequency note (heterodyne) to be heard in the headphones. The frequency of this note will be equal to the difference between the two frequencies. The audio frequency filter which is incorporated in the plate circuit of the first audio frequency stage of the receivers is designed to provide high attenuation of frequencies above

3500 cycles. Therefore, in most cases, only interference causing a heterodyne of less than 3000 cycles will concern the operator.

5-39 In attempting to eliminate undesired interference heterodynes when receiving voice modulated signals, adjusting the SELECTIVITY control to the SHARP position will often reduce the interference and permit the signal to be copied. This adjustment will cause a reduction in level of the desired signal. The adjustment will also affect the quality of the modulation of the received signal as it tends to eliminate the high audio frequencies inherent in the transmitted signal. This cannot be considered a disadvantage, however, when it permits more satisfactory readability under interference conditions.

5-40 Further attenuation of the interference caused by an undesired signal on an adjacent channel may be obtained by slightly detuning the set with the TUNING control to the side of the signal opposite that on which the undesired signal is located. This serves to attenuate both signals, but will attenuate the undesirable signal to a greater extent than the desired signal. Readjustment of the GAIN control may be necessary if this procedure is carried far enough to produce a drop in the level of the signal in the headphones. The procedure will distort the audio components of the received signal. However, this distortion will not present a serious disadvantage, if it permits the desired signal to be understood where it might otherwise be lost.

5-41 Another condition of interference encountered when receiving a voice modulated signal can be caused by another voice modulated signal on an adjacent channel when the fundamental frequency of the undesired signal does not itself cause interference. When the modulated envelope of the undesired signal extends under modulation, the sideband "splatter" affects the reception of the desired signal. This effect is heard in the headphones as a harsh, scratchy, and raspy sound. The condition may often be remedied by the tuning methods outlined in Paragraphs 5-39, and 5-40.

5-42 The success of the operator in reading any type of signal under interference conditions lies largely in the skill with which he employs the adjustments suggested in Paragraphs 5-29 to 5-41 inclusive. Careful analysis by the operator of the actions of the controls after he has developed famili-

arity with their operation will increase his operating skill and ability to receive signals under interference conditions.

CARE OF THE STORAGE BATTERIES (FIELD SERVICE)

5-43 It is strongly recommended that the batteries be kept in a charged condition at all times since the receivers may be called upon at any time to operate from the batteries alone to avoid the noise from the charging generator during security watches and the reception of weak signals. Information on charging batteries in the field is contained in Paragraph 6-7.

BASE STATION CHECK-UP OF THE STORAGE BATTERIES

5-44 After the storage batteries have been in use in the field for any considerable length of time, they should be given a thorough check-up at the base station in accordance with instructions in Part VI of this book.

OPERATION OF THE RECEIVERS FROM THE CHARGING GENERATOR ALONE

5-45 Should it be necessary, the receiving equipment may be operated from the charging generator alone, with the batteries disconnected from the circuit. The cable from the DYNAMOTOR ASSEMBLY to the generator is left in place and the battery cable removed. When operating the equipment in this manner, care should be taken to make certain that the voltage supplied by the generator as shown on the LINE VOLTS meter in the DYNAMOTOR UNIT does not drop below 11 volts or rise above 12 volts. The rheostat on the charging generator should be adjusted so that the LINE VOLTS meter indicates between 11 and 12 volts, and readjusted whenever the LINE VOLTS meter indicates that voltage in this range is not being provided.

BASE STATION OPERATION

Dual Operation

5-46 The RBM-5 Receiving Equipment may be used in a base station or wherever 60 cycle single phase alternating current is available. The equipment, when operated under these conditions, should be connected as shown on Fig. 69, Interconnection Diagram Dwg. P-7713095. If an operating table is available at the base station, the two receivers may be removed from their watertight Transportation Case and placed on top of the table. This arrangement is known as Dual operation. All control fea-

tures present and described in the DYNAMOTOR ASSEMBLY are available in the CONTROL UNIT and the description of the controls on the DYNAMOTOR UNIT, Paragraphs 5-16 to 5-24 inclusive will apply for the controls on the CONTROL UNIT. When connecting the equipment for Dual operation at the base station, it is necessary to slide each RECTIFIER POWER UNIT a short distance out of its box to set the switch directly back of the front panel to DUAL. Refer to Figure 45 for the location of this switch. Placing these switches in the DUAL position places the RECTIFIER POWER UNIT, supplying the M.F. Receiver, under the control of the MF POWER switch and the RECTIFIER POWER UNIT, supplying the H.F. Receiver, under control of the HF POWER switch on the CONTROL UNIT.

5-47 With the equipment set up for Dual operation as described in Paragraph 5-46, the operation

of all controls and the tuning procedure are exactly as described in Paragraphs 5-2 to 5-41 inclusive.

Single Operation

5-48 If it is desired to operate the two receivers singly and in separate parts of the base station, connection of the equipment should be as shown in Fig. 70, Dwg. 7713094. Slide the RECTIFIER POWER UNITS partly from their cabinets and set the switch back of the panel to SINGLE. Replace the chassis and snap the main power switches to the ON position. This operation applies low voltage and high voltage to the receivers. The MAIN POWER switches on the front panels of the RECTIFIER POWER UNITS now become effective to control line power to the RECTIFIER POWER UNITS and serve during SINGLE operation, as the ON-OFF switches for the receivers to which they supply power.

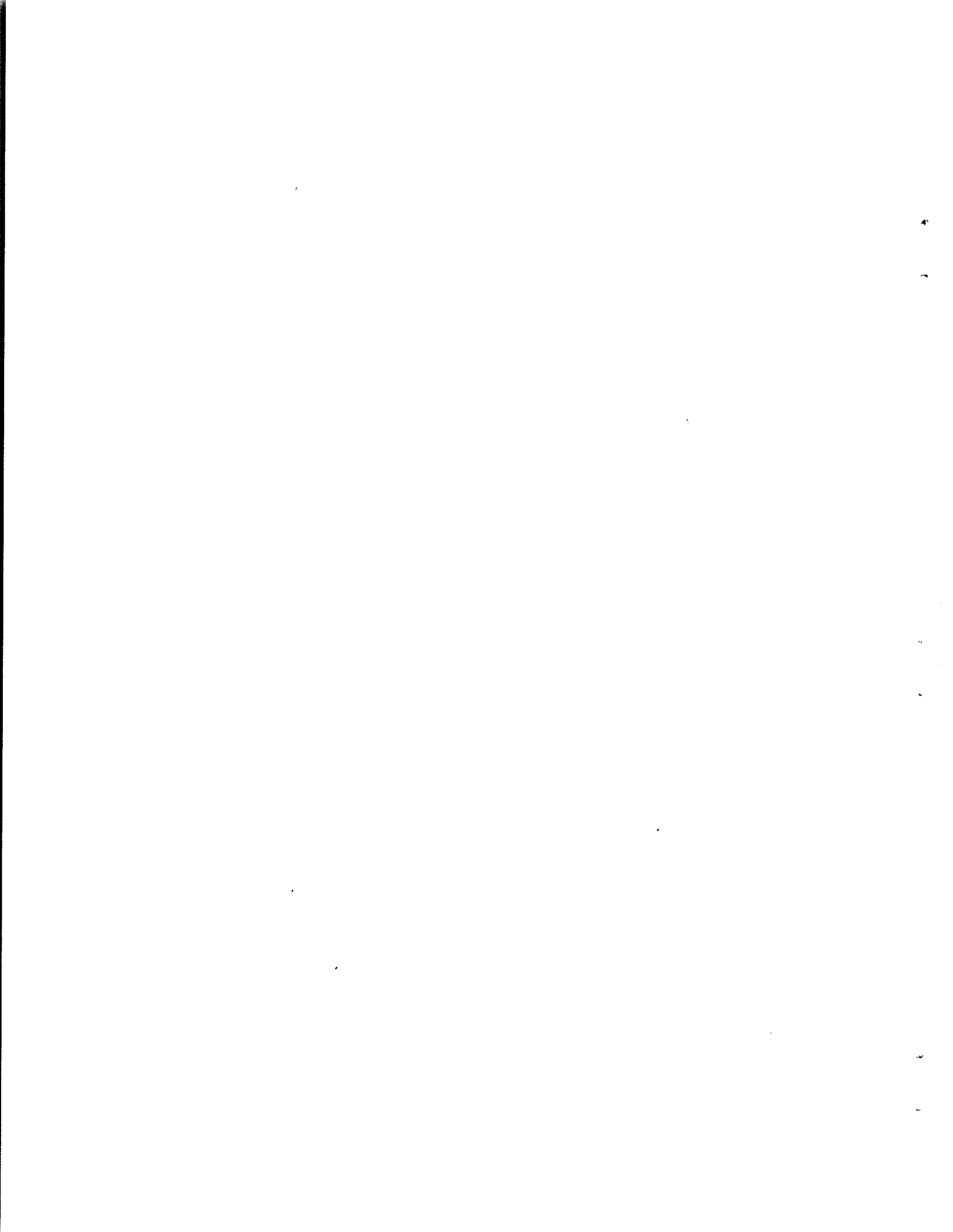

VI. Portable Storage Batteries

INITIAL PLACEMENT IN SERVICE

6-1 The two Type CES-19017 PORTABLE STORAGE BATTERIES which are supplied with the Model RBM-5 Semi-Portable Radio Receiving Equipment are shipped dry-charged in initial delivery of the equipments. The electrolyte necessary for their operation is shipped with the battery in special containers. Because of the operations involved in placing these batteries in condition for initial service, and in order to eliminate the necessity for transporting the containers of electrolyte in field service, it is recommended that the batteries be given the necessary conditioning at a base station before the equipment is taken in the field.

Unpacking and Handling

6-2 The containers of the batteries are made of aluminum which is protected outside and inside with a special acid-resisting lacquer. Care should be taken in unpacking and handling the batteries to avoid scratching this lacquer and thus permitting corrosion of the case by acid fumes and liquid acid from the batteries. The batteries should be handled carefully at all times, to prevent denting or deforming the case or covers, and thus affecting the security of the watertight seals.

Adding the Electrolyte

6-3 The electrolyte for each battery is shipped separately in a glass container. With each container is a special syringe which consists of a soft rubber bulb and a hard rubber tube provided with small holes $\frac{3}{8}$ inch from the bottom for the purpose of withdrawing excess acid from the battery. The electrolyte is added to the battery in the following manner:

- (1) Loosen and remove the two wing nuts which hold the top of the battery case in position.
- (2) Remove the top of the battery case carefully by lifting directly upward on the hold-down bar across the top of the case. **DO NOT ATTEMPT TO PRY THE COVER FROM THE CASE.** This may bend the case out of shape and make

it impossible for the watertight seals to function when the cover is replaced.

- (3) Remove the non-spill vent plugs from the six vent holes in the top of the battery.
- (4) With the syringe, fill each cell of the battery with electrolyte until the level of the electrolyte is $\frac{1}{2}$ " above the protector on top of the separators. Then withdraw the excess acid while holding the end of the syringe tube against the protector.
- (5) Carefully wipe out any electrolyte spilled in the top of the battery with a dry cloth or waste.

DO NOT ATTEMPT TO PUT ALL THE ELECTROLYTE IN THE CONTAINER INTO THE BATTERY. A little more electrolyte than is required to fill the battery is supplied to make up for losses due to spilling while filling the battery.

6-4 The electrolyte supplied with the battery is dilute sulphuric acid of 1.275 specific gravity. In case the container of electrolyte has been lost or broken during shipment, initial filling of the battery can be made with any dilute sulphuric acid of 1.275 specific gravity and of sufficient purity to be suitable for storage battery use. The temperature of the electrolyte and battery at the time of filling should not exceed 90°F. (32°C.) In case electrolyte other than supplied with the batteries is used in the initial filling, use only glass, hard rubber or lead containers for storage, or for filling the battery.

Initial Charge

6-5 Allow the battery to stand at least one hour after filling and check to see if the electrolyte falls below the proper level ($\frac{1}{2}$ inch above the protector on top of the separators in each cell). If the level has fallen, restore to proper level before charging by adding more electrolyte. A drop in the level of the electrolyte is not necessarily an indication that the battery is leaking, as often, during the initial filling, "air pockets" form within the cell which cause a false level of the electrolyte. When these "air pockets" break, the electrolyte level falls and additional electrolyte must be added before charging.

The initial charge is given in the following manner:

- (1) The battery cover may be removed during the initial charge. Remove the non-spill vent plugs only when taking hydrometer readings and cell temperatures.
- (2) Attach the charging connections to the battery posts in the top of the battery making certain that the positive cable of the charger is attached to the positive terminal of the battery and the negative cable from the charger is attached to the negative terminal of the battery. The polarity of the battery terminals may be determined by the indications on the battery terminals or on the outside of the case below the connection box. The positive terminal is indicated by a "+" or "POS" marking or is painted red, while the negative terminal is indicated by a "-" or "NEG" marking, or is painted black.
- (3) The positive and negative terminals are connected to the number 1 and number 2 contacts, respectively, of the receptacle marked P1601 on the terminal box of the batteries. Charging connections may be made through this connector if a suitable cable and plug are available and connected to the charger to assure proper terminal polarity. Two batteries may be charged in parallel by the use of Cable W-1701, supplied with the equipments, when it is used to connect the receptacle marked P1701 in one battery and the receptacle marked P1702 in the second battery.
- (4) Charge at an initial charging rate of $2\frac{1}{2}$ amperes per battery. Do not exceed this rate.
- (5) CHARGE UNTIL FOUR CONSECUTIVE HOURLY READINGS SHOW NO INCREASE IN THE GRAVITY AND VOLTAGE OF THE LOWEST CELL. The specific gravity of the battery should then read between 1.275 and 1.285 when measured with a hydrometer. The time necessary for this initial charge should not exceed 18 hours.
- (6) Do not allow the temperature of the battery to exceed 110°F. (43°C.). Reduce the charging rate, which will lengthen the charging time or stop the charge, if necessary, to keep the temperature under the safe limit of 110°F. (43°C.).
- (7) If necessary to restore the level of the electrolyte during the charging period, add only distilled water.

- (8) See that the non-spill vent plugs are securely in place on the battery and tighten the wing nuts to obtain a watertight seal. Tighten the wing nuts by hand only. DO NOT USE TOOLS. Replace the watertight ventilation plug in the top of the case, secure the carrying straps in position. The battery is now ready for field service.

MAINTENANCE WHILE IN FIELD SERVICE

6-6 The exigencies of field service, such as will be encountered in the normal use of the batteries, will preclude any except the bare essential maintenance operations. The conditions of operation of the equipment in the field will also require a special type of charging schedule. It is necessary to maintain the batteries in a high state of charge at all times in preparation for operation during "Security" watches. It is not practical to operate the gasoline-driven charging generator (a part of the TBW series transmitting equipments) due to the noise of the exhaust. Paragraphs 6-7 and 6-8, directly following, discuss these special requirements. Paragraphs 6-9 to 6-15 inclusive contain special data for service and maintenance when the batteries are returned to the base station.

Charging the Batteries (Field Service)

6-7 In the normal field operating set-up where the receiving equipment is associated with the Model TBW-5 Radio Transmitting Equipment, the connection between the Type CDO-73004-B gasoline-driven generator and the DYNAMOTOR ASSEMBLY is in position at all times. Thus, while the generator is in operation to supply power to the transmitters, a charge will be delivered to the batteries if the rheostat on the generator is adjusted to deliver current to the DYNAMOTOR ASSEMBLY. In addition, special opportunities should be found during slack periods of operation and watch, in order to operate the generator specifically to build up the charge in the batteries. When charging the batteries, the following procedure should be followed.

- (1) The condition of the batteries should be tested for their state of charge by operating both receivers simultaneously and observing the voltage registered on the LINE VOLTS meter in the DYNAMOTOR ASSEMBLY. If, under these conditions, (full load on the batteries, generator not operating) the voltage on the LINE VOLTS meter reads 11.5 volts, the batteries may be con-

sidered charged and ready for service. If the LINE VOLTS meter reads between 10.5 and 11.5 volts, the batteries are indicated to be in a state of partial charge, the relative state of charge being roughly determined by the voltage between 10.5 and 11.5 volts indicated by the meter. If the LINE VOLTS meter indicated 10.5 volts (or below) the batteries are discharged and should be charged immediately.

- (2) If the batteries need charging, make certain that the ventilation plug is removed from the top of the battery case and start the gasoline-driven generator. Adjust the rheostat of the generator to the full ON position so that the rate of charge as read on the generator ammeter is as great as possible.
- (3) Continue charging the batteries until two consecutive hourly readings (taken with the MAIN POWER switch ON, and MF and HF POWER switch OFF on the DYNAMOTOR UNIT, and with the generator operating) indicate no change in voltage on the LINE VOLTS meter. This indicates that the batteries are fully charged.

Maintenance and Repairs (Field Service)

6-8 The exigencies of field service do not permit extensive maintenance or service in the field. However, the following operations are deemed essential to maintain the batteries in condition.

- (1) Examine level of electrolyte in each cell of the battery each time the equipment is moved and at a period not longer than once each week while the equipment is in operation at a fixed field position. This procedure is as follows:
 - (a) Loosen the wing-nuts which hold the cover in place and remove the cover, observing the cautions stated in Paragraph 6-3 (2).
 - (b) Remove the spill-proof vent plugs from each cell and inspect the level of the electrolyte visually. (DO NOT USE A STICK OR METAL ROD TO MEASURE THE LEVEL OF THE ELECTROLYTE.)
 - (c) If the level of the electrolyte is $\frac{1}{2}$ inch above the protector on the top of the separator of each cell, the level of the cell may be considered satisfactory.
 - (d) Where the level of the electrolyte is below $\frac{1}{2}$ inch above the protector on the top of

the separator of each cell, distilled water should be added to the cell to obtain the $\frac{1}{2}$ inch level.

- (e) Replace vent plugs and the cover of the case, tightening the wing-nuts by hand only to obtain a watertight seal between the top and the case.
- (2) Inspect the inside of the top of the case at regular intervals, especially after transportation and when the battery has received a wetting. Wipe out regularly with a dry rag or cotton waste. Wash hands with a saturated solution of baking soda or other neutralizing agent.
 - (3) Do not open the connector box on the side of battery since the entrance of water has been made practically impossible by thorough sealing of the joints. If it is necessary to replace the connectors, J-1301 or J-1302, remove the connector box cover by releasing the two wing-nuts. DO NOT PRY OFF THE COVER. To do so may warp the box or top and prevent an effective watertight seal, while the box is open. The connections should be inspected, and tightened, if loose. Observe caution when working inside the case with metal tools to avoid shorting the battery. Before and after re-assembling the connector box apply B.F. Goodrich Company's Plastikon Cement No. 169 to the joints at the front and rear of the box.

- (4) Make certain that carrying straps are securely buckled to avoid dropping the battery while being handled or transported.
- (5) Clean and recover with acid-resistant lacquer (if available) all scratches in the lacquered surfaces of the case and top. If suitable lacquer is not available, broken surfaces should be wiped out regularly to prevent excess corrosion from acid and acid fumes until the battery can be returned to the base station for service.

BASE STATION MAINTENANCE AND SERVICE

6-9 Discussion in the following paragraphs assumes the return of the batteries to a base station equipped for battery service, with personnel experienced in handling storage batteries of the lead-acid type. This material is presented in data form for the use of such personnel in servicing and reconditioning the batteries.

Base Station Charging Procedure

6-10 The following charging procedure is recommended for charging the Type CES-19017 PORTABLE STORAGE BATTERIES:

- (1) Charge at a rate of 6 amperes (per battery) until the voltage, read across the battery terminals, is 14.1 volts while the 6 ampere charge is being delivered to the battery.
- (2) When the voltage reaches 14.1 volts, measured under the above conditions, reduce the charging rate to 3 amperes and continue until two hourly voltage readings are the same.

Full Charge Specific Gravity and Gravity Adjustments

6-11 For the Type CES-19017 batteries, the specific gravity of the electrolyte with the cells fully charged and the electrolyte well mixed and at a level of 1/2 inch within the battery, is as follows:

50° F.	80° F.	110° F.
1.285 to 1.295	1.275 to 1.285	1.265 to 1.275

This table shows the effect of temperature on the specific gravity reading as taken with a standard hydrometer or equivalent. A change of 30°F. changes the gravity reading .010, or ten points on the normal hydrometer scale. This specific gravity reading is adjusted within the above limits after initial charge and will not require adjusting during the life of the battery unless electrolyte is actually lost from the cells. Observe the specific gravity of the electrolyte in all the cells. If the range of the specific gravity in any cell or cells exceeds a range of 1.275 to 1.285 at 80°F., or the full-charge specific gravity corrected for temperature indicated above, adjust the specific gravity of the cell or cells found deficient to within the proper limits. This is accomplished by the following procedures:

(1) Low Specific Gravity

- (a) Charge the battery at a rate of 2 1/2 amperes until all cells are gassing. Take hydrometer and voltage readings of the cells to be adjusted until two consecutive hourly readings indicate no further rise in specific gravity or voltage. Make certain that this maximum specific gravity, corrected for temperature, is below the proper corrected specific gravity for a fully charged cell. CAUTION: NEVER ADJUST A CELL THAT DOES NOT GAS.

- (b) Remove some electrolyte and replace with 1.325 electrolyte, repeating this step if, after an hour's charging to allow the electrolyte to mix thoroughly, the specific gravity of the cell has not reached the desired value.
- (c) Repeat until the specific gravity at the end of an hour's charging period, corrected for temperature, is within the limits set in the previously given table.

Where it is desired to adjust high specific gravity, the following procedure should be followed:

(2) High Specific Gravity

- (a) Charge the battery at a rate of 2.5 amps. until all cells are gassing and take hydrometer and voltage readings of the cells to be adjusted until the specific gravity and voltage do not rise any higher over a 3-hour period. The maximum specific gravity obtainable, corrected for temperature, should be below the proper specific gravity for a fully charged cell. CAUTION: NEVER ADJUST A CELL WHICH DOES NOT GAS.
- (b) Remove some electrolytic and replace with distilled water. Charge the battery for an hour to allow the electrolyte to mix thoroughly and measure the specific gravity.
- (c) If the specific gravity, corrected for temperature, is within the limits prescribed in the above chart, the operation is completed. If not, repeat until proper specific gravity is obtained.

Adding Water

6-12 Water must be added regularly to each cell. Keep the level between the high and low points shown below.

<i>High Level</i>	<i>Low Level</i>
1/2" above protector on top of separators.	Top of separators.

6-13 The time of adding water is important in the winter time if the battery is not in a heated room. When it is cold, add water just before charging the battery in order to mix the water with the electrolyte by the charging current. If water is added and the battery left standing in freezing temperatures, the water will freeze just the same as though it was outside the battery.

6-14 Nothing but water is required to be added to storage batteries under normal charging conditions. Never add acid, electrolyte or any special powders, solutions or jellies.

6-15 A great many special powder solutions or jellies are injurious, having a corrosive or rotting action on the battery plates, reducing the voltage and capacity of the cells.

6-16 Electrolyte loses some of its water by charging of the battery and a little by evaporation, but acid is never lost in this manner. Therefore, no acid or electrolyte will need to be added unless some electrolyte should be spilled or lost from the cell, which loss is usually the result of carelessness in not keeping the vent plugs tight or in adding water too high. Add only distilled water.

6-17 If the cells flood or sputter electrolyte, the level is too high and should be lowered by withdrawing electrolyte. Keep vent plugs tight in the cells.

6-18 All the cells in the battery should take the same amount of water. If one cell takes more than the others, examine it for leakage.

Discharging Rates and Capacity

6-19 The capacity of a storage battery is measured in units of ampere hours, which is the product of the electrical current in amperes multiplied by the time in hours. Each Type CES-19017 Portable Storage Battery has a capacity at the 5-hour rate of 34 ampere hours, or 5 hours x 6.8 amperes = 34 ampere hours. Although current may be obtained after the end of this time, the voltage of the battery has dropped to a point beyond which it is not useful in operating the equipments.

Battery Freezing Temperatures

6-20 The freezing point of the battery electrolyte depends upon its specific gravity, the table below showing how this varies.

<i>Specific Gravity</i>	<i>Freezing Point</i>
1.275	— 85° F.
1.250	— 62° F.
1.225	— 35° F.
1.200	— 16° F.
1.175	— 4° F.
1.150	+ 5° F.
1.125	+ 13° F.
1.100	+ 19° F.

6-21 From this table it can be seen that there is little danger of freezing in a temperate climate zone except with a completely discharged battery. Moreover, at these freezing points the solution is slushy and does not become hard until the temperature goes still lower.

6-22 If water is added to a battery in freezing temperatures and the battery let stand in the cold and not charged to mix the water with the electrolyte, the water will remain on top and freeze.

Cleaning the Battery

6-23 Brush dirt off with a stiff bristle (not metal) brush. Wiping with a cloth wet with bicarbonate of soda solution (one pound of soda to a gallon of water) will neutralize any electrolyte sprayed or spilled out. Then wash battery with water, making sure vent plugs are tight in place. Examine vent plugs to make sure the gas escape holes are clear.

6-24 If any corrosion is experienced, scrape or brush off. Then washing with soda solution will neutralize any electrolyte remaining on the metal surfaces. After rinsing in water and drying, a thin coating of Vaseline or equivalent should be applied. Lead does not corrode. Lead-plated parts on which the lead coating is worn or scraped off should be replaced.

Greasing Bolted Connections

6-25 For permanently clean bolted connections, the surfaces to be in contact should be cleaned by scraping lightly. Then apply a film of Vaseline or equivalent to the cleaned surfaces, also to the bolt studs. After tightening, wipe off the surplus grease. See paragraph 6-8 (3).



VII. Maintenance

ROUTINE INSPECTION

7-1 In the interest of avoiding trouble, the entire radio receiving equipment should be thoroughly inspected at least after every 30 hours of operation. Check particularly the following points:

7-2 Check for Looseness and Wear

- (1) Loosening of the mountings of the units and the screws and nuts in general.
- (2) Mechanical and electrical condition of all cables and plugs.

7-3 Cleaning and Adjusting

- (1) Check the condition of all fuses to see that their ferrules have not become corroded and clean them with fine crocus cloth, if necessary.
- (2) Check all vacuum tube contacts to see that they have not become loose or corroded, and clean them with fine crocus cloth, if necessary.
- (3) Examine contacts of Relay K-601 in the DYNAMOTOR ASSEMBLY for excessive wear. Do not adjust the relay unless absolutely necessary.
- (4) Wipe all ceramic insulators, switches, etc., free from dirt or dust.
- (5) Clean switches and the grounding brush contacts of the four-gang tuning capacitor when inspection indicates the contact surfaces are dirty. Clean only with soft cloth and carbon tetrachloride. **DO NOT USE AN ABRASIVE.** Avoid bending the thin blades during handling.
- (6) Should the equipment be exposed to the effects of salt water spray, it should be wiped clean and dry, removing all traces of moisture. A very small amount of light oil on a soft cloth wiped over the etched nameplates will preserve the finish and prevent the corrosive action of salt water spray.

Portable Storage Batteries

7-4 See Part VI, PORTABLE STORAGE BATTERIES.

General

7-5 All of the aluminum used in the equipment has been treated to resist the effects of salt water spray. Should this surface treatment be scratched or broken, seal the exposed surface with clear lacquer. Care should be given to see that after any screws or nuts have been removed, the surface under each lock-washer is properly treated with clear lacquer. However, in the case of grounding screws, electrical contact must be maintained.

REPLACEMENTS

7-6 The only components which may normally be expected to require occasional replacement are the vacuum tubes. In general, however, whenever the performance of the equipment is below its previous standard, the tubes should be checked by comparison with fresh tubes.

7-7 If due to abnormal conditions, other components such as transformers, reactors, resistors, etc., fail, they should be replaced by similar units as listed under the heading of "PARTS LIST—PART X."

LUBRICATION

7-8 The tuning dial bearings and the front and rear ball bearings of the four-gang tuning capacitor should be lubricated once every six months with a few drops of light penetrating oil, such as a good typewriter oil. If the switches and grounding brush contacts of the four-gang tuning capacitor require cleaning or show signs of cutting, renew the lubrication by the use of Vaseline applied very sparingly. Remove all surplus Vaseline.

DYNAMOTOR MAINTENANCE

7-9 The dynamotors should be inspected every thirty days to see that the brushes are not worn excessively and that the commutators are not burned or grooved. This is accomplished by removing each dynamotor and its shock-mount from the DYNAMOTOR ASSEMBLY by releasing the four snap slide fasteners. Remove the end housings from the dynamotors. Remove the brushes from the brush-

holders and measure the length of the brush on one edge. When the brushes measure $\frac{3}{16}$ " or less they should be replaced with brushes from the spare parts. *Always replace brushes in pairs.* When placing brushes in the brush-holders always make certain that the brushes are accurately fitted in the guides, are against the commutator and will not bind or stick in the guides.

7-10 Carbon dust collects on the parts adjacent to the brushes, and should be blown away, or wiped away with a soft cloth.

7-11 The commutators eventually become darkened from brush action. This is not harmful, but it is advisable to clean them occasionally with fine (No. 00) sandpaper. NEVER USE EMERY CLOTH OR EMERY PAPER ON THE COMMUTATORS. NEVER ATTEMPT TO CLEAN COMMUTATORS OR REPLACE BRUSHES WHILE THE UNIT IS RUNNING. REMOVE THE DYNAMOTORS FROM THE CHASSIS AND ROTATE THE ARMATURE BY HAND.

7-12 Should the commutator become grooved or roughened, the armature should be removed from the dynamotor and the commutator accurately turned down in a lathe. After the commutator is turned down the mica should be undercut.

7-13 The bearings of the dynamotor are lubricated for 1000 hours of operation when the unit is shipped from the factory. To lubricate, remove the end covers and the bearing retainer plates and apply sufficient Navy Aeronautical Spec. M-372 grease to cover the bearings. Do not pack the bearings. Do not allow grease to get on the commutator. The following specific grades of grease meet the above specification or are approved as the equivalent thereof for particular use in this dynamotor:

<i>Grade</i>	<i>Manufacturer</i>
"Lubrico M-6"	Master Lubricants Company Philadelphia, Penna.
"F-927"	New York and New Jersey Lubricant Company New York, New York
"Andoc C"	Standard Oil Company of Louisiana Baton Rouge, Louisiana

VIII. Troubles, Location and Remedy

NORMAL SENSITIVITY OF THE RECEIVERS

8-1 The normal sensitivity of either the M.F. Receiver or the H.F. Receiver, determined as the number of microvolts required to produce an output of 6 milliwatts (1.9 volts) into a 600 ohm resistive load, is better than 15 microvolts when measured under the following conditions:

- (1) Supply voltage.
 - (a) 11.5 volts as measured on the LINE VOLTS meter in the DYNAMOTOR ASSEMBLY if the test is conducted on power from storage batteries.
 - (b) 115 volts A.C., measured at the power line socket with the receivers operating if the test is conducted on A.C. power from a line power supply.
- (2) HF and IF SIDE TONE switches on the DYNAMOTOR ASSEMBLY or CONTROL UNIT in the OFF position.
- (3) MF and HF PHONE TRANSFER switch on the DYNAMOTOR ASSEMBLY or CONTROL UNIT in the SEPARATE position.
- (4) SELECTIVITY control in the SHARP position.
- (5) RECEPTION control set to MOD or CW position.
- (6) Output load of 600 ohms pure resistance.
- (7) Signal fed to the receiver input through I.R.E. standard dummy antenna (1938).
- (8) ANT COMP control adjusted for maximum output at the high frequency end of each band.
- (9) With the RECEPTION CONTROL in the MOD position, the signal generator is adjusted to provide a carrier modulated 30% at a frequency of 1000 c.p.s. The GAIN control of the receiver is adjusted so that the signal-to-

noise ratio is 10 decibels. This ratio is determined as the ratio between an output signal of 6 milliwatts from the modulation, and the noise level remaining when the modulation is removed and only the R.F. carrier is present. When these conditions are obtained, the microvolt output of the signal generator may be compared with the normal sensitivity of 15 microvolts or better to determine the condition of the receiver.

- (10) With the RECEPTION control in the CW position, an unmodulated carrier is used. The RECEPTION CONTROL is adjusted to the CW position and the GAIN CONTROL is adjusted so that the receiver produces 0.19 volts across the dummy load (600 ohms) with the receiver input shorted through the standard dummy antenna. The signal output from the signal generator required to produce 6 milliwatts, (1.9 volts), with the antenna short removed, is the measure of the efficiency of the receiver when compared with the normal sensitivity of 15 or better microvolts.

8-2 The sensitivity of the receiver will be subject to variations due to tube aging and other factors. IT IS RECOMMENDED THAT NO ATTEMPT BE MADE TO RETRIM OR REALIGN THE RECEIVERS UNLESS THE SENSITIVITY IS FOUND TO BE LESS THAN 20 MICROVOLTS WITH NEW AVERAGE TUBES.

STAGE-BY-STAGE TROUBLE-SHOOTING DIAGRAM

8-3 Reference should be made to Fig. 73, Dwg. P-7709095, "Stage-By-Stage Trouble-Shooting Diagram" when attempting to locate and correct troubles in either the M.F. Receiver or the H.F. Receiver. This diagram outlines a simple routine to follow in locating troubles, and gives specific references to paragraphs describing in detail the procedure to follow after the trouble has been localized in any stage. Referring to Fig. 73, assume that the condi-

tion of the receiver indicates "Weak or No Signal All Bands" with the RECEPTION control in the MOD position, the service man starts following the block diagram at the point where this condition is indicated. The arrow leading from this block to the next block indicates the next step the service man is to take. This is "Check Dyn. or A.C. Line Fuses." If these fuses are found to be OK, the next step is to "Check Tubes." If the fuses are found to be blown, the other arrow is followed. This leads to the box "Check Dyn. or Rectifier Pwr. Supply," together with the reference to the paragraph which describes the procedure to follow. Used in this manner, the "Stage-By-Stage Trouble-Shooting Diagram" will assist in locating the trouble in a quick, orderly manner.

WEAK OR NO SIGNALS ON ALL BANDS

Check of Dynamotor Assembly or Rectifier Power Unit and Control Unit

8-4 Remove the fuses from their receptacles on the back skirt of the DYNAMOTOR ASSEMBLY or RECTIFIER POWER UNIT chassis and inspect visually, or test with an ohm-meter. If found to be blown, this usually indicates a defect in the DYNAMOTOR ASSEMBLY.

8-5 When signals on all bands are weak, or no signals are heard when known to be present, the procedure to follow is indicated on the chart. After having checked the fuses and found one or more to be blown, check the DYNAMOTOR ASSEMBLY or RECTIFIER POWER UNIT voltages at the C.F.I. receptacle. The voltage between terminal 26 and terminal 27 should be approximately 205 volts D.C. and between terminal 25 and terminal 27, approximately 11.6 volts D.C. on the DYNAMOTOR ASSEMBLY and 12 volts A.C. on the RECTIFIER POWER UNITS, depending upon the condition of the batteries, or the line voltage. If the voltage readings do not approximate these values, the DYNAMOTOR ASSEMBLY or RECTIFIER POWER UNIT circuit should be checked for open circuits, short circuits, or defective parts. "Point-to-Point Resistance Tables" for use while checking these units are contained in Paragraphs 8-6, 8-7 and 8-8. Refer to Wiring Diagram, Fig. 58, Dwg. T-7611585 when checking the DYNAMOTOR ASSEMBLY, or Fig. 60, Dwg. P-7711546 and Fig. 61, Dwg. T-7611584, for the RECTIFIER POWER UNIT and CONTROL UNIT, respectively and to the Parts List, Part X, Table II, for data concerning the components.

8-6 Dynamotor Assembly Point-to-Point Resistance Table

POINTS	RESISTANCE OHMS	CONDITION
Contact 69 to Contact 70 on J608	105	TABLE LIGHT OFF MF POWER at PLATE ON
Contact 69 to Contact 70 on J608	250	MF POWER switch at PLATE ON, TABLE LIGHT, OFF
Contact 49 on J607 to Contact 3 on J604	280	
Contact 49 on J606 to Contact 3 on J603	280	
Contact 1 to Contact 2 on Dynamotor Unit D601	.4	
Contact 2 to Contact 3 on Dynamotor Unit D601	180	

The above values apply to the DYNAMOTOR ASSEMBLY with all cables and both dynamotors removed.

8-7 Rectifier Power Unit Point-to-Point Resistance Table

POINTS	RESISTANCE OHMS	CONDITION
Type CAY-20086		
Contact 49 to Contact 52 Transformer Term. 6 to Contact 49	10,000 ohms	
Contact 50 to Contact 52	215 ohms	
Contact 4 to Contact 6 on Rectifier Socket	0.15 ohms	
Contacts on LINE Receptacle	85 ohms	
	1.9 ohms	MAIN POWER Switch ON

The above values apply to the RECTIFIER POWER UNIT with all cables disconnected.

8-8 Control Unit Point-to-Point Resistance Table

POINTS	RESISTANCE OHMS	CONDITION
Type CAY-23278		
Contacts on LINE Receptacle	60 ohms	MAIN POWER switch ON
Contacts on LINE Receptacle	38 ohms	MAIN POWER switch ON and MF POWER at FIL ON
Contacts 25 to 27 on CFI Receptacle	.73 ohms	

The above values apply to the CONTROL UNIT with all cables disconnected.

Tube Checks

8-9 If the voltages at the C.F.I. receptacle approximate the values given, proceed to check all tubes for transconductance or emission, short circuits between elements, or open heaters, with a tube analyzer. If this is not done, replace all tubes with a set of tubes known to be of average characteristics, and check the performance of the receiver. Replace any defective tubes from the spare parts.

Check of Socket Voltages

8-10 If tubes check satisfactorily, or if after replacing with tubes known to be good, receiver sensitivity is still low or no signals can be heard, check the voltages between the tube socket contacts and the chassis of the receiver under the following conditions: Battery Operation, 11.5 volts from the batteries as indicated on the LINE VOLTS meter on the DYNAMOTOR ASSEMBLY. A.C. Line Operation, 115 volts, 60 cycle A.C. if the RECTIFIER POWER UNITS are used. For diagram giving tube socket contact arrangement, refer to Fig. 74, Dwg. P-7709096. The GAIN control should be set to "100," and RECEPTION switch to "CW." For in-

formation on removing shields to test inside the chassis, see Paragraph 8-30.

Voltage Chart Receiver Tube Socket Contacts to Chassis

8-11 The data in this chart represents measurements on the M.F. and H.F. Receivers, and has been prepared especially for the preliminary instruction book. Data representing average measurements on production units will be provided in the final instruction book for the equipments. The following voltages will represent an average value, satisfactory for servicing and checking the receivers. Refer to Fig. 74, Dwg. P-7709096 for tube socket diagram.

SOCKET	M.F. RECEIVER					TERMINAL			
	1	2	3	4	5	6	7	8	
			V	V	V	V	AC	DC	V
X 401 (RF)	0	0	0.1	0	1	64	12	11.6	195
X 402 (CONV)	0	0	6.7	0	6.7	170	12	11.6	204
X 403 (HET.OSC.)	0	0	110	*3-12		110	12	11.6	155
X 404 (1 I.F.)	0	0	2.7	0	2.7	136	12	11.6	197
X 405 (2 I.F.)	0	0	2.7	0	2.7	136	12	11.6	197
X 406 (2 DET.)	0	0	-3	0	-2	197	12	11.6	0
			-2		Δ-1				
X 407 (AVC)	0	0	0	33.5	0		12	11.6	0
				Δ6.5					
X 408 (CW.OSC.)	0	0	0	-4	0	33	12	11.6	160
X 409 (1 A.F.)	0	0	0	0	1.6	35	12	11.6	54
X 410 (2 A.F.)	0	0	9.3	0	9.3	175	12	11.6	52
X 411 (3 A.F.)	0	0	106	112	0	9.3	12	11.6	5.8

The above average operating voltage values are as obtained by measurement with a Model OE Radio Receiver Analyzing Equipment.

* Varies with FREQ. BAND and dial setting.
 Δ RECEPTION Switch at AVC.

SOCKET	H.F. RECEIVER					TERMINAL			
	1	2	3	4	5	6	7	8	
			V	V	V	V	AC	DC	V
X 501 (RF)	0	0	1.5	0	1.5	116	12	11.6	193
X 502 (CONV)	0	0	6	0	6	142	12	11.6	203
X 503 (HET.OSC.)	0	0	1.43	*3-2.6		143	12	11.6	185
X 504 (1 I.F.)	0	0	1.5	0	1.5	116	12	11.6	193
X 505 (2 I.F.)	0	0	1.5	0	1.5	116	12	11.6	193
X 506 (2 DET.)	0	0	-35	0	-2	0	12	11.6	0
			Δ-1		-1				
X 507 (AVC)	0	0	0	2.6	0		12	11.6	0
				Δ3.9					
X 508 (CW.OSC.)	0	0	0	-35	0	34	12	11.6	141
X 509 (1 A.F.)	0	0	0	0	1.6	35	12	11.6	54
X 510 (2 A.F.)	0	0	9.3	0	9.3	175	12	11.6	52
X 511 (3 A.F.)	0	0	106	112	0	9.3	12	11.6	5.8

The above are average operating voltage values as obtained by measurement with a Model OE Radio Receiver Analyzing Equipment.

* Varies with FREQ. BAND and dial setting.
 Δ RECEPTION switch at AVC.

Check of Circuit Wiring and Components

8-12 If the tube socket voltages do not approximate the voltages given in the chart "Voltages, Tube Socket Contacts to Chassis," Paragraph 8-11, the circuits should be checked for grounds, shorts, open connections and similar defects. A preliminary check for such conditions in the circuit may be made with a standard ohm-meter directly at the tube sockets by

comparing the actual resistance measurements derived at the socket contacts with the chart below. Resistance measurements which vary more than +20% from the figures given in this chart will usually indicate a circuit defect, localizing the trouble in the part of the circuit associated with the tube socket contact. If found defective, replace defective components using spare. Refer to Fig. 74, Dwg. P-7709096 for tube socket diagrams.

8-13 Resistance Chart; Tube Socket Contacts to Chassis
(Refer to Fig. 74, Dwg. P-7709096 for Tube Socket Diagram.)

MEDIUM FREQUENCY RECEIVER CONTACTS

Stage	Socket	1	2	3	4	5	6	7	8
R.F.	X-401	0	0	1-10	(2.6 MEG (*3.5 MEG	125	32000	0.5	20000
CONV.	X-402	0	0	1500	(2.6 MEG (*3.5 MEG	1500	50000	0.5	20000
HET.OSC.	X-403	0	0	50000	10000	0.5	50000	0.5	23000
1 I.F.	X-404	0	0	390	(1.1 MEG (*2.8 MEG	390	50000	0.5	20000
2 I.F. DET.	X-405	0	0	390	1 MEG	390	19000	0.5	20000
NOISE LIM.	X-406	0	0	.44 MEG	0	.22 MEG	20000	0.5	2.1 MEG
AVC	X-407	0	0	(.28 MEG (*1.2 MEG	19000 *21000	0		0.5	0
B.F.O.	X-408	0	0	0	15000	4.6	.5 MEG	0.5	52000
1 A.F.	X-409	0	0	*1.2 MEG	2.5 MEG	1000	.45 MEG	0.5	.13 MEG
2 A.F.	X-410	0	0	1500	1.5 MEG	1500	.11 MEG	0.5	.28 MEG
3 A.F.	X-411	0	0	2800	27500	.47 MEG	15000	0.5	620

The above readings are applicable under the following conditions:

- (1) Power input cable disconnected.
- (2) Gain set at 100
- (3) RECEPTION set at CW.
- (4) "Good" tubes in all sockets.
- (5) Dial light dimmer rotated clockwise.
- (6) Noise Limiter "ON".

* RECEPTION set on AVC.

HIGH FREQUENCY RECEIVER CONTACT

Stage	Socket	1	2	3	4	5	6	7	8
R.F.	X-501	0	0	160	(2.6 MEG (*3.2 MEG	160	18500	0.5	18500
CONV.	X-502	0	0	1500	(2.3 MEG (*4.1 MEG	1500	85000	0.5	18500
HET. OSC.	X-503	0	0	52000	20000	0	52000	0.5	19000
1 I.F.	X-504	0	0	150	(.4 MEG (*.96 MEG	150	18500	0.5	18500
2 I.F. DET.....	X-505	0	0	150	2.2	150	18500	0.5	18500
NOISE LIM.....	X-506	0	0	.44 MEG	0	.22 MEG (.31 MEG (*1.3 MEG	0.5	2.1 MEG
AVC	X-507	0	0	(.31 MEG (*1.3 MEG	2900	0		0.5	0
B.F.O.	X-508	0	0	0	47000	0.8	.5 MEG	0.5	75000
1 A.F.	X-509	0	0	(0	(2.2 MEG (*1.8 MEG	1000	.45 MEG	0.5	.13 MEG
2 A.F.	X-510	0	0	15000	1.5 MEG	15000	.11 MEG	0.5	.28 MEG
3 A.F.	X-511	0	0	28000	27500	.47 MEG	15000	0.5	620

The above readings are applicable under the following conditions:

- (1) Power input cable disconnected.
- (2) Gain set at 100
- (3) RECEPTION set at CW.
- (4) "Good" Tubes in all sockets.
- (5) Dial light dimmer rotated clockwise.
- (6) Noise Limiter "ON".

*RECEPTION set to AVC.

Test of Audio Amplifier

8-14 Having checked all socket voltages and resistances and found the values correct, proceed to test the audio frequency amplifier. This can be checked by coupling the 30% modulated output of Navy Type LN or LP Standard Signal Generator through a 500 mmfd. capacitor to contact #3 of the Second Detector Socket, X406 (X506). Proper functioning of the audio amplifier will be indicated by an output from the signal generator of approximately 0.5 volts for a 6 milli-watt output from the receiver into a 600 ohm resistive load (1.9 volts), measured with the OUTPUT LEVEL control set at 100, NOISE LIMITER OFF, and RECEPTION control set at MOD. If the receiver does not respond to this test, circuits, wiring and components should be checked and repaired or replaced. The connections may be checked by reference to Schematic and Wiring Diagrams Fig. 62, Dwg. T-7611588 and Fig. 56, Dwg. T-7611589 respectively for the MEDIUM FREQUENCY RECEIVER or Fig. 63, Dwg. T-7611586 and Fig. 57, Dwg. T-7611587 for the HIGH FREQUENCY RECEIVER. Useful data for checking individual components may be found in Part X—PARTS LIST, Table II.

Tests of Intermediate Frequency Amplifiers

8-15 Following a satisfactory test of the audio amplifier, check the intermediate frequency amplifier stages by connecting the signal generator output (modulated 30% at 1000 c.p.s.) to contact #4 of the Converter Tube Socket, X402 (X502) through a 500 mmfd. capacitor. Adjust the GAIN control to 82, OUTPUT LEVEL control to 100, RECEPTION control to MOD, and SELECTIVITY control to SHARP. Tune the signal generator to approximately 140 kcs. for the M.F. Receiver and approximately 1255 kcs. for the H.F. Receiver. A rough check of the proper functioning of the I.F. amplifier is indicated by 100 microvolts input for the M.F. Receiver and 130 microvolts input for the H.F. Receiver for 6 milliwatts output.

Test of I.F. Amplifiers, Stage-By-Stage

8-16 If the test of the I.F. amplifier described in Paragraph 8-15 does not provide a response at the output of the receivers or produces a response indicating lack of sensitivity, it is necessary to test the I.F. amplifier stages individually. The signal generator is connected through a 500 mmfd. capacitor to contact #3 of the Second Detector Socket X406 (X506) and the signal generator tuned to resonance at the intermediate frequency of the receiver under test (M.F. Receiver, 140 kcs., H.F. Receiver, 1255

kcs.). The output of the signal generator is adjusted to give 6 milliwatts output from the receiver into a 600 ohm load, and the output from the signal generator recorded. The connection to the signal generator is then moved to terminal #4 of Socket X405 (X505) and the output of the signal generator adjusted to give 6 milliwatts at the output of the receiver across the dummy load of 600 ohms pure resistance. The gain of the second I.F. amplifier stage is then determined by dividing the number of microvolts necessary to produce an output of 6 milliwatts when fed into the second detector by the number of microvolts required for the same output when fed into the second I.F. amplifier. The result should be approximately 34 for the M.F. Receiver and 22 for the H.F. Receiver. In a similar manner the signal generator is now coupled to terminal #4 of socket X404 (X504) and the signal generator again adjusted to give a 6 milliwatt output. The gain of the first I.F. amplifier stage is calculated similarly from the input level of the second and first I.F. stages. This should approximate 22 for the M.F. Receiver and 19 for the H.F. Receiver. The signal generator should next be connected to terminal #4 of the Converter Tube Socket X402 (X502) and the gain similarly measured and computed. This should approximate 7.7 for the M.F. Receiver and 8 for the H.F. Receiver. If the I.F. stage gains do not approximate the values given above and in Paragraph 8-22, "Stage Gain Chart, M.F. and H.F. Receivers" the trouble can be assumed to be located.

Alignment of I.F. Amplifier

8-17 When all stages have been checked, the I.F.

Amplifier may be aligned by coupling a 30% modulated signal (140 kcs. for the M.F. Receiver and 1255 kcs. for the H.F. Receiver) to contact #4 of the Converter Tube Socket X402 (X502). Adjust the SELECTIVITY control to the SHARP position, the GAIN control to 85, the OUTPUT LEVEL control to 100 and the RECEPTION control to MOD. Align Trimmer Capacitors C451A (C551A), C451B (C551B), C445A (C545A), C445B (C545B), C440A (C540A) and C440B (C540B) in order given for maximum receiver output. Maintain the receiver output below 50 milliwatts during the alignment of the trimmer capacitors by reducing the signal input as the output from the receiver increases. This is a complete alignment, effective in both the BROAD and SHARP positions of the SELECTIVITY control. After alignment, the stage gains should approximate the figures given in Paragraphs 8-16 and 8-22.

Test of Heterodyne Oscillator

8-18 Having checked the functioning of the I.F. Amplifiers, if trouble is still indicated, the Heterodyne Oscillator circuit should next be checked. Connect the signal generator (modulated 30% at 1000 c.p.s.) through a 500 mmfd. capacitor to contact #4 of the Converter Tube Socket X402 (X502). Tune to a frequency on the band under test and measure the number of microvolts required for 6 milliwatt output. If there is no response to this signal or the number of microvolts differs substantially from 260 microvolts for the M.F. Receiver or 220 microvolts for the H.F. Receiver, the circuit should be checked for grounds, shorts, or defective components.

Alignment of Heterodyne Oscillator

8-19 With the signal generator still connected to contact #4 of the Converter Tube Socket X402 (X502), align the Heterodyne Oscillator in accordance with the alignment data given in Paragraphs 8-23 for the M.F. Receiver and 8-25 for the H.F. Receiver. This alignment of the oscillator does not constitute a final adjustment, it being necessary to complete the alignment in conjunction with the alignment of the R.F. Amplifier stages, as described in Paragraphs 8-23 and 8-25. Having aligned the oscillator on bands 1 through 4, or on the bands on which deficient performance has been indicated by tests described in Paragraph 8-18, proceed with a check of the R.F. Amplifier.

Test of R.F. Amplifier

8-20 Introduce a 30% modulated signal into the antenna input to the receiver through a standard dummy antenna under the conditions described in Paragraph 8-1 (1 to 10 inclusive). Tune the signal generator to resonance with the receiver and adjust the output of the signal generator to give 6 milliwatt output from the receiver. If the R.F. Amplifiers are in average condition, the signal input should not exceed 10 to 15 microvolts.

R.F. Amplifier Circuit Check

8-21 If the input to the receiver substantially exceeds 15 microvolts for a 6 milliwatt output when measured under the conditions described in Paragraphs 8-1 and 8-2, a circuit check, stage-by-stage, should be made. With the signal generator output (modulated 30% at 1000 c.p.s.) introduced through a 500 mmfd. capacitor to contact #4 of the R.F. Amplifier Tube Socket X401 (X501), tune the generator to resonance with the receiver and adjust the signal generator output to give an output of 6 milliwatts from the receiver into a 600 ohm resistive load. Move the signal generator connection to contact #4 of the Converter Tube Socket X402 (X502) and repeat the procedure. The gain indicated by this reading when divided by the reading taken at contact #4 of Socket X401 (X501) should approximate the figures shown on the table, Paragraph 8-22. Proceed to the antenna and measure the gain of the input stage in a similar manner. Divide the microvolt reading obtained when adjustments are completed with the signal generator attached to the antenna terminal into the microvolt reading obtained when the signal generator was connected to terminal #4 of X401 (X501). The resulting figure should be approximately as shown in Paragraph 8-22. Anything more than nominal variation from the figures shown in Paragraph 8-22 indicates a defective circuit condition in that stage. Circuit check the defective stage for grounds, shorts, or defective components. Correct wiring defects and replace defective components with proper units from the spare supplied with the equipment.

Stage Gains Chart, M.F. and H.F. Receivers

8-22 Gain control adjusted to give 4.5 volts from terminal 3 or 5 of the 1st or 2nd I.F. tube socket to chassis, input adjusted to give 6 milliwatts (1.9 volts) output across 600 ohms resistive load, RECEPTION set at MOD and OUTPUT LEVEL set at 100.

MEDIUM FREQUENCY RECEIVER

Measured	Freq-Kcs	Band	Gain	Condition
2nd Det. Plate.....	140		.55 V. input	
2nd I.F. Grid to Det. Plate.....	140		34	
1st I.F. Grid to 2nd I.F. Grid.....	140		23.8	SELECTIVITY SHARP
1st I.F. Grid to 2nd I.F. Grid.....	140		21.1	SELECTIVITY BROAD
Converter Grid to 1st I.F. Grid.....	140		8.5	SELECTIVITY SHARP
Converter Grid to 1st I.F. Grid.....	140		6.7	SELECTIVITY BROAD
R.F. Grid to Converter Grid.....	360	1	7.6	
R.F. Grid to Converter Grid.....	650	2	9.3	
R.F. Grid to Converter Grid.....	1140	3	5.6	
R.F. Grid to Converter Grid.....	2000	4	8.0	
Antenna Input to R.F. Grid.....	360	1	6.9	Signal applied to
Antenna Input to R.F. Grid.....	650	2	8.4	Standard Dummy Antenna
Antenna Input to R.F. Grid.....	1140	3	6.5	connected to Receiver.
Antenna Input to R.F. Grid.....	2000	4	5.3	Input. ANT. COMP control
				adjusted for each band.
				Refer to Para. 8-1.

HIGH FREQUENCY RECEIVER

Measured	Freq-Mcs	Band	Gain	Condition
2nd Det. Plate.....	1.255		.5 V. input	
2nd I.F. Grid to 2nd Det. Plate.....	1.255		22	
1st I.F. Grid to 2nd I.F. Grid.....	1.255		19	SELECTIVITY SHARP
1st I.F. Grid to 2nd I.F. Grid.....	1.255		19	SELECTIVITY BROAD
Converter Grid to 1st I.F. Grid.....	1.255		18.1	SELECTIVITY SHARP
Converter Grid to 1st I.F. Grid.....	1.255		8	SELECTIVITY BROAD
R.F. Grid to Converter Grid.....	3.6	1	9.7	
R.F. Grid to Converter Grid.....	6.5	2	9.6	
R.F. Grid to Converter Grid.....	11.4	3	11	
R.F. Grid to Converter Grid.....	20.0	4	6	
Antenna Input to R.F. Grid.....	3.6	1	4.3	Signal applied to
Antenna Input to R.F. Grid.....	6.5	2	3.3	Standard Dummy Ant.
Antenna Input to R.F. Grid.....	11.4	3	2.5	connected to Receiver.
Antenna Input to R.F. Grid.....	20	4	2.1	Input ANT COMP adjusted
				for each band. Refer
				Paragraph 8-1.

Alignment of the R.F. Amplifier (M.F. Receiver)

8-23 Connect the signal generator output to the receiver input thru a 500 mmfd. capacitor, set SELECTIVITY control to SHARP and rotate the ANT COMP control fully clockwise. Set the receiver to Band 1 and tune the receiver to 360 kilocycles. Set the signal generator to 360 kcs., (modulated 30% at 1000 c.p.s.) and adjust the Trimmer Capacitors C436, C411, C417 and C422 in the order given for maximum output from the receiver. Repeat on the other bands in accordance with "R.F. Amplifier Alignment Table, M.F. Receiver", Paragraph 8-24. Replace the 500 mmfd. capacitor with the standard dummy antenna and adjust the ANT COMP control for maximum receiver output. Replace covers over the antenna, R.F. and converter stage trimmer capacitors. Shift the receiver dial to 1250 kcs, on band 4. Adjust the heterodyne Oscillator Trimmer L413 by means of the fillister head screw for maximum output and then tune the receiver slightly higher or slightly lower in frequency, adjusting L413 for each frequency until an adjustment is obtained which gives maximum output. Repeat the adjustment of C433 at 1950 Kcs., and L413 at 1250 kcs. until perfect alignment results. Align the other bands in accord-

ance with the above method at the frequencies given in the table, Paragraph 8-24 (below), adjusting the ANT COMP control once at the high frequency end of the band. Tune the receiver to 200 kcs. on band 1, set SELECTIVITY control to BROAD and tune the signal generator to 141 kcs., with 30% modulation at 1000 c.p.s. and adjust L423 for MINIMUM receiver output. Tune the signal generator from 135 to 145 kcs. and note the relative response at the peaks. If the peaks are not equal, readjust L423 at a slightly different input frequency, repeating until the peaks are equal. Replace and secure all trimmer covers.

8-24. R.F. Amplifier Alignment Table (M.F. Receiver)

Band	Freq. (kcs.)	Align. Freq. (kcs.)	Trimmers In Order	Align. Freq. (kcs.)	Inductance Adj.
1	200- 360	360	C436, C411, C417, C422	200	L416
2	360- 650	650	C435, C410, C416, C421	400	L415
3	650-1140	1140	C434, C409, C415, C420	700	L414
4	1140-2000	1950	C433, C408, C414, C419	1250	L413
1	(Special Trap Adjustment, See Test)	200		141	L423

Alignment of the R.F. Amplifier (H.F. Receiver)

8-25 Connect the signal generator to the receiver input through a standard dummy antenna. Set the receiver to band 1, RECEPTION control to MOD and SELECTIVITY control to SHARP and tune the receiver to 3.6 mcs. and ANT COMP control to "5 right". Set the signal generator to 3.6 mcs., modulated 30% at 1000 c.p.s., and align Trimmer Capacitors C536, C511, C517 and C522 in the order given for greatest output from the receiver. Repeat the other bands in accordance with the Table given in Paragraph 8-26. Replace covers over the antenna, R.F. and detector stage trimmers. Shift the signal generator frequency to 11.75 mcs. and set the receiver to 11.75 mcs. on band 4. Adjust the High Frequency

Oscillator Inductance Trimmer L513 by means of the fillister head screw to provide maximum output from the receiver. Then tune the receiver slightly higher or slightly lower in frequency, adjusting L513 for each frequency until a simultaneous tuning and adjustment gives a maximum output. Repeat the adjustment of C533 at 19.5 mcs. and L513 at 11.75 mcs. until a perfect alignment results. Align the other bands in accordance with the above procedure at the frequencies given in the "R.F. Amplifier Alignment Table, H.F. Receiver", Paragraph 8-26, adjusting the ANT COMP control once at the high frequency end of each band. Replace and secure all trimmer covers.

8-26 R.F. Amplifier Alignment Table (H.F. Receiver)

Band	Freq.	Ant. Comp.	Align. Freq. (kcs.)	Trimmers In Order	Align. Freq. (kcs.)	Induct. Adj.
1	2.0- 3.6	5 (R)	3.6	C536, C511, C517, C522	2.05	L516
2	3.6- 6.5	5 (R)	6.5	C535, C510, C516, C521	3.70	L515
3	6.5-11.4	5 (R)	11.4	C534, C509, C515, C520	6.50	L514
4	11.4-20.0	5 (R)	19.5	C533, C508, C514, C519	11.75	L513

WEAK OR NO SIGNALS ON ONLY ONE BAND

8-27 A condition of satisfactory reception on one or more bands and weak or no signals on one band indicates the correct functioning of the I.F. and A.F. Amplifiers, A.V.C. and Detector circuits and requires only the checking of the R.F. Circuits for the defective band or bands. When such a condition is encountered, the procedures outlined in Paragraphs 8-18 to 8-26 inclusive should be followed on the defective bands only.

WEAK OR NO SIGNALS, C.W. ONLY

8-28 A condition of satisfactory reception of modulated signals on all bands, and weak or no reception of C.W. signals, indicates proper functioning of all parts of the receiver with the exception of the Beat Frequency Oscillator (B.F.O.). If this condition prevails, check the B.F.O. Tube, V408 (V508) for transconductance, short or open circuits, or replace with a tube of known average characteristics. If the receiver still does not respond to C.W. signals, and the tube checks satisfactorily or has been replaced with one of known average characteristics, proceed to check the tube socket voltages as given in Paragraph 8-10. If these voltages approximate the values given in Paragraph 8-11, proceed to check circuit wiring and components as described in Paragraphs 8-12 and 8-13 for grounds, short or open

circuits. Repair defective wiring and replace defective components with proper units from the spare parts.

Alignment of Beat Frequency Oscillator (B.F.O.)

8-29 Connect the output of the signal generator (30% modulated at 1000 c.p.s.) to contact No. 4 of the Converter Tube Socket X402 (X502) through a 500 mmfd. capacitor and set the SELECTIVITY control to SHARP, the RECEPTION control to MOD and GAIN control to 85. Resonate the signal generator to the receiver at approximately 140 kcs. for the M.F. Receiver and 1255 kcs. for the H.F. Receiver. Adjust the signal generator to give a 10 milliwatt output from the receiver into a 600 ohm resistive load. Detune the signal generator both higher and lower than the I.F. frequency of the receiver under test until the output into the dummy load is reduced to 2½ milliwatts. Record the signal generator dial settings at these two points. Then set the signal generator to the average value of these two readings. Switch the RECEPTION control to CW. Replace the dummy load with a pair of telephone headsets. With the BEAT NOTE control set exactly at zero (0), adjust the Trimmer Capacitor C472 (C572) counterclockwise from zero beat with the carrier signal to zero beat with the 1000 cycle modulation from the signal generator. Replace and secure the oscillator trimmer cover.

MEASUREMENTS AND CIRCUIT CHECKS, GENERAL

Removing Receiver Shields

8-30 Before making any circuit checks or tests inside the receiver it is necessary to remove the receiver shields. This is accomplished by removing the two binding head screws from each slide rail. The slide rails are laid aside and the shield is slid from the receiver, after removing the holding screws. The rear end of the shield is dropped clear of the shockmounts, and can be removed easily from the receiver.

Voltage, Measurements, General

8-31 The procedure outlined in this paragraph and the voltage measurements which comprise the voltage charts in this instruction book are based upon the use of a Navy Model OE Receiver Analyzer. For general checking of voltages when using batteries, the voltage supplied to the DYNAMOTOR ASSEMBLY from the storage batteries should indicate 11.5 volts on the LINE VOLTS meter of the DYNAMOTOR ASSEMBLY. When 115 Volt A.C. supply is used with the required base station power supply units, the line voltage should be adjusted to the exact level indicated for operation of the units (115 Volts A.C.).

Set up the analyzer and check the voltages in accordance with the following procedure.

- (1) Be sure all plug connections are secure.
- (2) All readings will be D.C., except those made from terminal No. 7 on any tube socket to chassis when operating with the RECTIFIER POWER UNIT. These voltages will be A.C.
- (3) Select the appropriate voltage range by rotating the selector switch of the analyzer to the proper position.
- (4) Set the RECEPTION control of the receiver to the MOD position unless otherwise specified.
- (5) Set the GAIN control to 100 unless otherwise specified. Set the tuning control to 200 kcs. for the M.F. Receiver and to 2mcs. for the H.F. Receiver. Readings should deviate but slightly when switching to other bands with the tuning

control remaining in the low frequency position of each band.

- (6) Meter indications within $\pm 10\%$ of the values in Tube Socket Voltages Chart, Paragraph 8-11, will, in most cases, indicate proper operation.

Resistance and Continuity Measurements

8-23 Set up the receiver as for measurements of voltage, but remove the power cable from the connector in the rear of the receiver chassis. Set the analyzer for resistance measurements by rotating the selector switch to the suitable range. Before taking a resistance reading on any of the ranges, short the two test leads together and rotate the ohm-meter adjuster until the instrument pointer reads exactly zero ohms. In general, ohm-meter readings will be the most accurate when the pointer indicates on the upper two-thirds of the scale. Whenever possible, a range should be selected which will give indications in this scale area. If the analyzer is so adjusted, resistance measurements will be approximately as tabulated in the chart, "Resistance, Ohms Tube Socket Contacts to Chassis" given in Paragraph 8-13, with power cables disconnected and GAIN set to 100. Meter indications within $\pm 20\%$ of these values will in most cases indicate proper operation.

Testing Tubes

8-33 Vacuum tube data in this instruction book has been derived by use of the Navy Type OD Vacuum Tube Analyzer. When testing tubes with this analyzer, adjustment of the analyzer should be made in accordance with the instruction book supplied with the analyzer in order to insure accurate tube checking and proper results.

Checking Interconnection Cables

8-34 When troubles are indicated in the interconnection cables, they may be checked by using the ohm-meter section of the analyzer. Cables may be tested for continuity by removing them completely from the equipment and testing for zero ohms with the ohm-meter. While testing the cables, they should be moved around with the test prods in place in order to locate any intermittent short or open circuits. Cable contacts should be inspected, and cleaned with crocus cloth or carbon tetrachloride if found to be dirty or corroded.

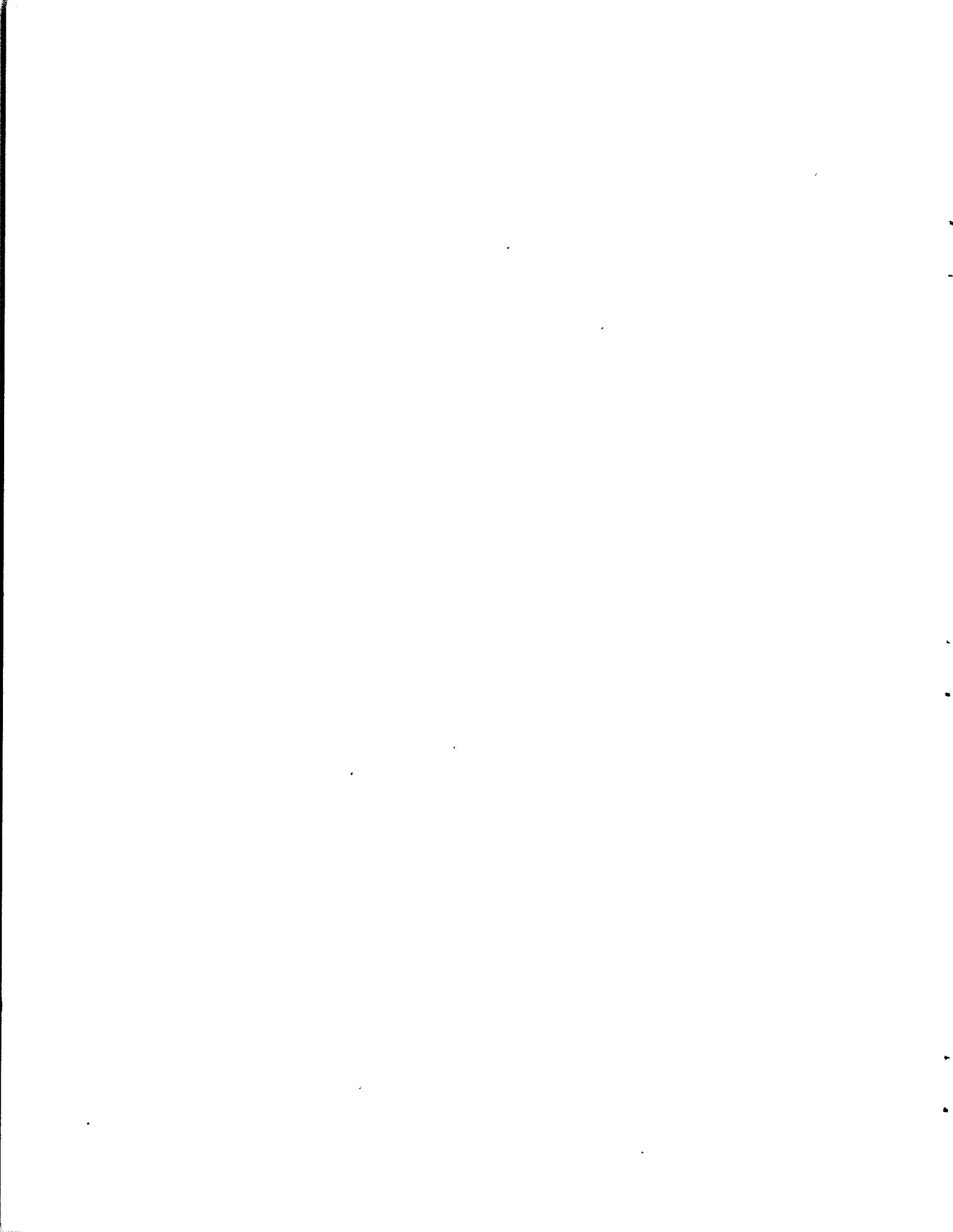

TABLE I
LIST OF MAJOR UNITS FOR
MODEL RBM-5 SEMI-PORTABLE RADIO RECEIVER EQUIPMENT

QUANTITY	SYMBOL GROUP	NAVY TYPE DESIGNATION	NAME OF MAJOR UNIT	ASSEMBLY DRAWING NUMBER
X	401 TO 599	CAY-46078A	RADIO RECEIVER ASSEMBLY	K-7810519 G-3 & G-4
1	401 TO 499	CAY-46076A	MEDIUM FREQUENCY RECEIVER	K-7810519 G-3
1	501 TO 599	CAY-46077A	HIGH FREQUENCY RECTIFIER	K-7810519 G-4
1	601 TO 699	CAY-21387A	DYNAMOTOR ASSEMBLY	K-7810430 G-2
X	701 TO 710	CLT-49069	DYNAMOTOR PLUG	P-7708342 G-3
	801 TO 899		UNASSIGNED	
2	901 TO 950	CAY-20086	RECTIFIER POWER UNIT, 60 CYCLE	K-7810419 G-2 & G-4
1	1001 TO 1050	CAY-23278	CONTROL UNIT, 60 CYCLE	K-7810495 G-2
	1101 TO 1299		UNASSIGNED	
2	1301 TO 1399	CES-19017	PORTABLE STORAGE BATTERY	T-7607718 G-1
1	1401 TO 1410		M. F. RECEIVER CABLE & PLUG	T-7608019 PT-698
1	1501 TO 1510		H. F. RECEIVER CABLE & PLUG	T-7608019 PT-699
1	1601 TO 1610		BATTERY TO DYNAMOTOR CABLE & PLUG	T-7608254 PT-101
1	1701 TO 1710		BATTERY TO BATTERY CABLE & PLUG	T-7608254 PT-102
1	1801 TO 1810		CHARGING GEN. TO DYN CABLE & PLUG	T-7608254 PT-103
1	1901 TO 1910		CONTROL BOX M. F. POWER INPUT CABLE & PLUG	T-7610373 PT-73
1	2001 TO 2010		CONTROL BOX H. F. POWER INPUT CABLE & PLUG	T-7610373 PT-74
1		CAY-10095	MOBILE SPARE PARTS, BOX #1	DL-7502420 LINE 9,15

I-01

TABLE II

PARTS AND SPARE PARTS LIST BY SYMBOL DESIGNATION FOR RBM-5 SEMI-PORTABLE RADIO RECEIVER EQUIPMENT

BATTERY OR 60 CY. A.C. SUPPLY	SYMBOL DESIG.	FUNCTION	DESCRIPTION	NAVY TYPE NUMBER	NAVY SPEC. OR DRAWING NUMBER	MFR.	MFR. DESIG.	SPECIAL TOL. RATING OR MODIFICATION	CONTRACTOR'S DRAWING AND PART NUMBER	SPARE PARTS	
										BOX NUMBER	QUANTITY
CAPACITORS (CLASS 48)											
X	C-401	ANTENNA COMPENSATOR CAPACITOR	7.5 MMFD. TO 110 MMFD. VARIABLE AIR			6			T-7607868 P7		C-401
X	C-402	ANTENNA COMPENSATOR CAPACITOR	50 MMFD. ±10%, 500 V.D.C. WORKING, MICA	48895-B10	RE48A148C RE48A154F	2	1468 LS §		T-7608010 P2		C-402, C-454, C-455, C-554, C-555
X	C-403	ANTENNA COUPLING CAPACITOR BAND #4	5 MMFD. ±20%, 500 V.D.C. WORKING, MICA	48771-B20	RE48A148C RE48A154F	2	1468 LS §		T-7608010 P3		C-403, C-404, C-405
X	C-404	ANTENNA COUPLING CAPACITOR BAND #3	SAME AS C-403	48771-B20							
X	C-405	ANTENNA COUPLING CAPACITOR BAND #2	SAME AS C-403	48771-B20							
X	C-405	ANTENNA COUPLING CAPACITOR BAND #1	10 MMFD. ±10%, 500 V.D.C. WORKING, MICA	48710-D10	RE48A148C RE48A154F	2	1469 §		T-7608010 P6		C-406, C-484, C-485, C-487, C-488, C-584, C-585, C-587, C-592
X	C-407	BY-PASS A.V.C. CAPACITOR	0.01 MFD., 300 V.D.C. WORKING, MICA	48848-B10	RE48A143F RE48A154F	2	1467 LS §		T-7608010 P7		C-407, C-438, C-443, C-448, C-457, C-459, C-461, C-466, C-476, C-481, C-482, C-494, C-507, C-538, C-543, C-548, C-557, C-559, C-561, C-566, C-576, C-581, C-582, C-594, C-596.
X	C-408	R.F. GRID TRIMMER CAPACITOR BAND #4	3 MMFD. TO 25 MMFD., VARIABLE AIR			6			T-7607868 P1		C-408, C-409, C-410, C-411, C-414, C-415, C-416, C-417, C-419, C-420, C-421, C-422, C-433, C-434, C-435, C-436, C-508, C-509, C-510, C-511, C-514, C-515, C-516, C-517, C-519, C-520, C-521, C-522, C-533, C-534, C-535, C-536
X	C-409	R.F. GRID TRIMMER CAPACITOR BAND #3	SAME AS C-408								
X	C-410	R.F. GRID TRIMMER CAPACITOR BAND #2	SAME AS C-408								
X	C-411	R.F. GRID TRIMMER CAPACITOR BAND #1	SAME AS C-408								
X	C-412A	R.F. GRID TUNING CAPACITOR	168 MMFD., MAX. 4 SECTIONS, VARIABLE AIR			3			T-7607344 G1		C-412A, C-412B, C-412C, C-412D, C-512A, C-512B, C-512C, C-512D

§ WHEN ORDERING INCLUDE CAPACITY AND VOLTAGE.

TABLE II (CONTINUED)										SPARE PARTS		
PARTS AND SPARE PARTS LIST BY SYMBOL DESIGNATION FOR RBM-5 SEMI-PORTABLE RADIO RECEIVER EQUIPMENT										BOX NUMBER	QUANTITY	ALL SYMBOL DESIGNATIONS INVOLVED
BATTERY OR 60 CY. A.C. SUPPLY	SYMBOL DESIG.	FUNCTION	DESCRIPTION	NAVY TYPE NUMBER	NAVY SPEC. OR DRAWING NUMBER	MFR.	MFR. DESIG.	SPECIAL TOL. RATING OR MODIFICATION	CONTRACTOR'S DRAWING AND PART NUMBER			
CAPACITORS (CLASS 4B) CONTINUED												
X	C-412B	R.F. PLATE TUNING CAPACITOR	PART OF C-412A									
X	C-412C	1ST DET. GRID TUNING CAPACITOR	PART OF C-412A									
X	C-412D	OSC. TUNING CAPACITOR	PART OF C-412A									
X	C-413A	CATHODE BUB BY-PASS CAPACITOR	0.5 - 0.1 MFD., 600 V.D.C. WORKING, PAPER	-482057-10		2			T-7605996 P34		C-413A, C-413B, C-450A, C-450B, C-458A, C-458B, C-513A, C-513B, C-550A, C-550B, C-558A, C-558B	
X	C-413B	R.F. SCREEN BY-PASS CAPACITOR	(0.1 MFD) PART OF C-413A									
X	C-414	R.F. PLATE BAND #4 TRIMMER CAPACITOR	SAME AS C-408									
X	C-415	R.F. PLATE BAND #5 TRIMMER CAPACITOR	SAME AS C-408									
X	C-416	R.F. PLATE BAND #2 TRIMMER CAPACITOR	SAME AS C-408									
X	C-417	R.F. PLATE BAND #1 TRIMMER CAPACITOR	SAME AS C-408									
X	C-418	WAVE TRAP TUNING CAPACITOR	0.005 MFD., ±10%, 300 V.D.C. WORKING MICA	-481037-B10	RE48A143 RE48A154F	2	1467 LS §		T-7608010 P22		C-418, C-480, C-580	
X	C-419	1ST DET. GRID TRIMMER CAPACITOR BAND #4	SAME AS C-408									
X	C-420	1ST DET. GRID TRIMMER CAPACITOR BAND #5	SAME AS C-408									
X	C-421	1ST DET. GRID TRIMMER CAPACITOR BAND #2	SAME AS C-408									
X	C-422	1ST DET. GRID TRIMMER CAPACITOR BAND #1	SAME AS C-408									
X	C-423	R.F. GRID COUPLING CAPACITOR	100 MMFD ±10%, 500 V.D.C. WORKING MICA	-48674-B10	RE48A148C RE48A154F	2	1468 LS §		T-7608010 P27		C-423, C-437, C-469, C-470, C-477, C-478, C-523, C-537, C-569, C-570, C-577	
X	C-424A	R.F. PLATE FILTER CAPACITOR	0.1 - 0.1 MFD., 400 V.D.C. WORKING, PAPER	-481465-10	RE48A129C	2			T-7606996 P16		C-424A, C-424B	
X	C-424B	1ST DET. SCREEN BY-PASS CAPACITOR	PART OF C-424A									

§ WHEN ORDERING INCLUDE CAPACITY AND VOLTAGE

TABLE II (CONTINUED)										SPARE PARTS		
PARTS AND SPARE PARTS LIST BY SYMBOL DESIGNATION FOR RE SEMI-PORTABLE RADIO RECEIVER EQUIPMENT										BOX NUMBER	QUANTITY	ALL SYMBOL DESIGNATIONS INVOLVED
BATTERY OR 60 CY. A.C. SUPPLY	SYMBOL DESIG.	FUNCTION	DESCRIPTION	NAVY TYPE NUMBER	NAVY SPEC. OR DRAWING NUMBER	MFR.	MFR. DESIG.	SPECIAL TOL. RATING OR MODIFICATION	CONTRACTOR'S DRAWING AND PART NUMBER			
CAPACITORS (CLASS 48) CONTINUED												
X	C-425	OSC. TRACKING CAPACITOR BAND #1	370 MMFD. ±1%, 500 V.D.C. WORKING, MICA	-481151-D1	RE48A148C RE48A154F	2	1469 §		T-7608010 P30		C-425	
X	C-426	OSC. TRACKING CAPACITOR BAND #2	580 MMFD. ±1%, 300 V.D.C. WORKING, MICA	-481614-D1	RE48A154F RE48A148C	2	1469 §		T-7608010 P31		C-426	
X	C-427	OSC. TRACKING CAPACITOR BAND #3	1190 MMFD. ±1%, 500 V.D.C. WORKING, MICA	-481487-D1	RE48AA143 RE48A154F	2	1464 §		T-7608010 P32		C-427	
X	C-428	OSC. TRACKING CAPACITOR BAND #4	2130 MMFD. ±1%, 500 V.D.C. WORKING, MICA	-481488-D1	RE48AA143 RE48A154F	2	1464 §		T-7608010 P33		C-428	
X	C-429	OSC. COMPENSATOR CAPACITOR BAND #4	30 MMFD. ±5%, -.00035 MMF/MMF/°C. ±15%, CERAMIC	-481461-5		4	CLASS D		T-7608010 P34		C-429	
X	C-430	OSC. COMPENSATOR CAPACITOR BAND #3	30 MMFD. ±5%, -.0003 MMF/MMF/°C. ±15%, CERAMIC	-481460-5		4	CLASS D		T-7608010 P35		C-430	
X	C-431	OSC. COMPENSATOR CAPACITOR BAND #2	25 MMFD. ±5%, -.0003 MMF/MMF/°C. ±15%, CERAMIC	-481808-5		4	CLASS D		M-7407312 P11		C-431	
X	C-432	OSC. COMPENSATOR CAPACITOR BAND #1	30 MMFD. ±5%, -.0001 MMF/MMF/°C. ±30%, CERAMIC	-481456-5		4	CLASS D		T-7608010 P37		C-432, C-532	
X	C-433	OSC. TRIMMER CAPACITOR BAND #4	SAME AS C-408									
X	C-434	OSC. TRIMMER CAPACITOR BAND #3	SAME AS C-408									
X	C-435	OSC. TRIMMER CAPACITOR BAND #2	SAME AS C-408									
X	C-436	OSC. TRIMMER CAPACITOR BAND #1	SAME AS C-408									
X	C-437	OSC. GRID COUPLING CAPACITOR	SAME AS C-423	-48674-B10								
X	C-438	OSC. 1ST DET. COUPLING CAPACITOR	SAME AS C-407	-48848-B10								
X	C-439A	OSC. SCREEN BY-PASS CAPACITOR	0.1-0.1-0.1 MFD., 600 V.D.C. WORKING, PAPER	-481925		2			T-7605996 P35		C-439A, C-439B, C-439C, C-539A, C-539B, C-539C	
X	C-439B	OSC. PLATE FILTER CAPACITOR	PART OF C-439A									
X	C-439C	1ST DET. PLATE FILTER CAPACITOR	PART OF C-439A			2						
X	C-440A	1ST I.F. PRIMARY TRIMMER CAPACITOR	7 MMF. TO 44 MMFD., 500 V.D.C. WORKING, TWO SECTIONS, VARIABLE AIR			6	ATF-14-F SPECIAL		T-7607868 P6		C-440A, C-440B, C-445A, C-445B, C-451A, C-451B, C-540A, C-540B, C-545A, C-545B, C-551A, C-551B	

§ WHEN ORDERING, INCLUDE CAPACITY AND VOLTAGE.

P-7713092

TABLE II (CONTINUED)										SPARE PARTS		
PARTS AND SPARE PARTS LIST BY SYMBOL DESIGNATION FOR RBM-5 SEMI-PORTABLE RADIO RECEIVER EQUIPMENT												
BATTERY OR 60 CY. A.C. SUPPLY	SYMBOL DESIG.	FUNCTION	DESCRIPTION	NAVY TYPE NUMBER	NAVY SPEC. OR DRAWING NUMBER	MFR.	MFR. DESIG.	SPECIAL TOL. RATING OR MODIFICATION	CONTRACTOR'S DRAWING AND PART NUMBER	BOX NUMBER	QUANTITY	ALL SYMBOL DESIGNATIONS INVOLVED
	CAPACITORS (CLASS 48) CONTINUED											
X	C-440B	1ST I.F. SECONDARY TRIMMER CAPACITOR	PART OF C-440A									
X	C-441	1ST I.F. PRIMARY TRIMMER CAPACITOR	310 MMFD. ±10%, 500 V.D.C. WORKING, MICA	-483554-D1	RE48A148 RE48A154F	2	1469 \$		T-7608010 P49			C-441
X	C-442	1ST I.F. SECONDARY TRIMMER CAPACITOR	225 MMFD. ±3%, 500 V.D.C. WORKING, MICA	-481489-D3	RE48A148 RE48A154F	2	1469 \$		T-7608010 P50			C-442, C-446, C-447, C-452, C-453
X	C-443	1ST I.F. A.V.C. BY-PASS CAPACITOR	SAME AS C-407	-48848-B10								
X	C-444A	1ST I.F. SCREEN BY-PASS CAPACITOR	0.1-0.1-0.1 MFO., 400 V.D.C. WORKING, PAPER	-481466	RE48AA129C	2			T-7605996 P17			C-444A, C-444B, C-444C, C-449A, C-449B, C-449C, C-468A, C-468B, C-468C, C-564A, C-544B, C-544C, C-549A, C-549B, C-549C, C-568A, C-568B, C-568C
X	C-444B	1ST I.F. PLATE FILTER CAPACITOR	PART OF C-444A									
X	C-444C	1ST I.F. CATHODE BY-PASS CAPACITOR	PART OF C-444A									
X	C-445A	2ND I.F. PRI. TRIMMER CAPACITOR	SAME AS C-440A									
X	C-445B	2ND I.F. SEC. TRIMMER CAPACITOR	PART OF C-445A									
X	C-446	2ND I.F. PRI. TRIMMER CAPACITOR	SAME AS C-442	-481489-D3								
X	C-447	2ND I.F. SEC. TRIMMER CAPACITOR	SAME AS C-442	-481489-D3								
X	C-448	1ST DET. A.V.C. BY-PASS CAPACITOR	SAME AS C-407	-48848-B10								
X	C-449A	2ND I.F. SCREEN BY-PASS CAPACITOR	SAME AS C-444A	-481466								
X	C-449B	2ND I.F. PLATE FILTER CAPACITOR	PART OF C-449A									
X	C-449C	2ND I.F. CATHODE BY-PASS CAPACITOR	PART OF C-449A									

WHEN ORDERING, INCLUDE CAPACITY AND VOLTAGE.

P-7713092

TABLE II (CONTINUED)

PARTS AND SPARE PARTS LIST BY SYMBOL DESIGNATION FOR RBM-5 SEMI-PORTABLE RADIO RECEIVER EQUIPMENT

SPARE PARTS

BATTERY OR A.C. SUPPLY	SYMBOL DESIG.	FUNCTION	DESCRIPTION	NAVY TYPE NUMBER	NAVY SPEC. OR DRAWING NUMBER	MFR.	MFR. DESIG.	SPECIAL TOL. RATING OR MODIFICATION	CONTRACTOR'S DRAWING AND PART NUMBER	BOX NUMBER	QUANTITY	ALL SYMBOL DESIGNATIONS INVOLVED
X	C-450A	1ST A.F. CATHODE BY-PASS CAPACITOR	SAME AS C-413A	-482057-10								
X	C-450B	1ST A.F. SCREEN BY-PASS CAPACITOR	(0.1 MFD) PART OF C-450A									
X	C-451A	3RD I.F. PRI. TRIMMER CAPACITOR	SAME AS C-440A									
X	C-451B	3RD I.F. SEC. TRIMMER CAPACITOR	PART OF C-451A									
X	C-452	3RD I.F. PRI. TRIMMER CAPACITOR	SAME AS C-442	-481489-D3								
X	C-453	3RD I.F. SEC. TRIMMER CAPACITOR	SAME AS C-442	-481489-D3								
X	C-454	SIGNAL DIODE FILTER CAPACITOR	SAME AS C-402	-48895-B10								
X	C-455	SIGNAL DIODE FILTER CAPACITOR	SAME AS C-402	-48895-B10								
X	C-456	A.V.C. DIODE COUPLING CAPACITOR	SAME AS C-423	-48674-B10								C-456, C-556
X	C-457	VOLUME CONTROL COUPLING CAPACITOR	SAME AS C-407	-48848-B10								
X	C-458A	1ST AUDIO PLATE FILTER CAPACITOR	SAME AS C-413A	-482057-10								
X	C-458B	2ND A.F. PLATE & SCREEN FILTER CAPACITOR	(0.1 MFD) PART OF C-458A									
X	C-459	A.V.C. FILTER CAPACITOR	SAME AS C-407	-48848-B10								
X	C-460A	2ND A.F. SCREEN BY-PASS CAPACITOR	0.5-0.1 MFD., 600 V.D.C. WORKING PAPER	-482058-10					T-7605996 P36			C-460A, C-460B, C-560A, C-560B
X	C-460B	3RD A.F. PLATE & SCREEN FILTER CAPACITOR	(0.5 MFD) PART OF C-460A									
X	C-461	PEAK LIMITER LOAD BY-PASS CAPACITOR	SAME AS C-407	-48848-B10								
X	C-462	FEED BACK CAPACITOR	1 MFD., 400 V.D.C. WORKING, PAPER	-481469	RE48A174C				T-7605996 P20			C-462, C-474, C-562, C-574
X	C-463	1ST AUDIO PLATE BY-PASS CAPACITOR	345 MMFD. ±5%, 500 V.D.C. WORKING, MICA	-481490-B5	RE48A140C RE48A154F		1468 LS § 26		T-7608011 P79			C-463, C-465, C-563, C-565
X	C-464	LOW PASS FILTER CAPACITOR	690 MMFD. ±5%, 500 V.D.C. WORKING, MICA	-481491-B5	RE48A140C RE48A164F		1468 LS § 26		T-7608011 P80			C-464, C-495, C-564, C-595

§ WHEN ORDERING INCLUDE CAPACITY AND VOLTAGE.

P-7713092

TABLE II (CONTINUED)										SPARE PARTS		
PARTS AND SPARE PARTS LIST BY SYMBOL DESIGNATION FOR RBM-5 SEMI-PORTABLE RADIO RECEIVER EQUIPMENT										SPARE PARTS		
BATTERY OR 60 CY. A.C. SUPPLY	SYMBOL	FUNCTION	DESCRIPTION	NAVY TYPE NUMBER	NAVY SPEC. OR DRAWING NUMBER	MFR.	MFR. DESIG.	SPECIAL TOL. RATING OR MODIFICATION	CONTRACTOR'S DRAWING AND PART NUMBER	BOX NUMBER	QUANTITY	ALL SYMBOL DESIGNATIONS INVOLVED
	DESIG.											
	CAPACITORS (CLASS 48) CONTINUED											
X	C-465	LOW PASS FILTER CAPACITOR	SAME AS C-463	-481490-B5								
X	C-466	3RD A.F. GRID COUPLING CAPACITOR	SAME AS C-407	-48846-B10								
X	C-467	CW OSC. COUPLING CAPACITOR	5 MMFD. ±10%, 500 V.D.C. WORKING, MICA	-48771-B10								C-467
X	C-468A	CW OSC. BY-PASS BY CAPACITOR	SAME AS C-444A	-481466								
X	C-468B	CW OSC. PLATE FILTER CAPACITOR	PART OF C-468A									
X	C-468C	CW OSC. HEATER BY-PASS CAPACITOR	PART OF C-468A									
X	C-469	2ND I.F. GRID COUPLING CAPACITOR	SAME AS C-423	-48674-B10								
X	C-470	CW OSC. GRID COUPLING CAPACITOR	SAME AS C-423	-48674-B10								
X	C-471	FIXED CW OSC. TRIMMER CAPACITOR	170 MMFD. ±3%, 500 V.D.C. WORKING, MICA	-481149-D3	RE48A148C RE48A154F	2	1469 §		T-7608011 P89			C-471
X	C-472	CW OSC. TRIMMER CAPACITOR	3 MMFD. TO 25 MMFD., VARIABLE AIR			6	ARL-21-N SPECIAL		T-7607868 P2			C-472, C-572
X	C-473	CW OSC. VERNIER CAPACITOR	2.8 MMFD. TO 10 MMFD., VARIABLE AIR			6	ARL-25-0 SPECIAL		T-7607868 P3			C-473
X	C-474	HIGH VOLTAGE BY-PASS CAPACITOR	SAME AS C-462	-481469								
X	C-475	SCREEN SUPPLY FILTER CAPACITOR	0.5 MFD., 400 V.D.C. WORKING, PAPER	-481470	RE48A138C	8		+10% -3%	T-7605996 P21			C-475, C-575
X	C-476	1ST A.F. GRID COUPLING CAPACITOR	SAME AS C-407	-48846-B10								
X	C-477	1ST DET. GRID COUPLING CAPACITOR	SAME AS C-423	-48674-B10								
X	C-478	1ST I.F. GRID COUPLING CAPACITOR	SAME AS C-423	-48674-B10								
X	C-479	1ST I.F. COUPLING CAPACITOR	15 MMFD. ±7%, 500 V.D.C. WORKING MICA	-48840-D7	RE48A148C RE48A154F	2	1469 §		T-7608011 P97			C-479, C-588, C-593
X	C-480	2ND A.F. GRID COUPLING CAPACITOR	SAME AS C-418	-481037-B10								
X	C-481	3-4 A.V.C. FILTER CAPACITOR	SAME AS C-407	-48848-B10								

§ WHEN ORDERING INCLUDE CAPACITY AND VOLTAGE.

TABLE II (CONTINUED)

PARTS AND SPARE PARTS LIST BY SYMBOL DESIGNATION FOR RBM-5 SEMI-PORTABLE RADIO RECEIVER EQUIPMENT

SPARE PARTS

BATTERY OR 60 CY. A.C. SUPPLY	SYMBOL	FUNCTION	DESCRIPTION	NAVY TYPE NUMBER	NAVY SPEC. OR DRAWING NUMBER	MFR.	MFR. DESIG.	SPECIAL TOL. RATING OR MODIFICATION	CONTRACTOR'S DRAWING AND PART NUMBER	BOX NUMBER	QUANTITY	ALL SYMBOL DESIGNATIONS INVOLVED
	DESIG.	CAPACITORS (CLASS 48) CONTINUED										
X	C-482	2-3 A.V.C. FILTER CAPACITOR	SAME AS C-407	48848-B10								
X	C-483	R.F. GRID FIXED TRIMMER CAPACITOR	5 MMFD. ±10%, ZERO COMPENSATION, 500 V.D.C. WORKING, CERAMIC	481480-10		4	CLASS D		T-7608011 P101			C-483, C-578
X	C-484	ANT. BAND 3 FIXED TRIMMER CAPACITOR	SAME AS C-406	48710-D10								
X	C-485	ANT. BAND 4 FIXED TRIMMER CAPACITOR	SAME AS C-406	48710-D10								
X	C-486	R.F. PLATE BAND 1 FIXED TRIMMER CAPACITOR	5 MMF. ±20%, 500 V.D.C. WORKING, MICA	48771-D20		2	1469 §		T-7608011 P104			C-486, C-583, C-586
X	C-487	R.F. PLATE BAND 2 FIXED TRIMMER CAPACITOR	SAME AS C-406	48710-B10								
X	C-488	R.F. PLATE BAND 3 FIXED TRIMMER CAPACITOR	SAME AS C-406	48710-D10								
X	C-489	R.F. PLATE BAND 4 FIXED TRIMMER CAPACITOR	30 MMFD. ±7%, 500 V.D.C. WORKING, PAPER	481327-D7	RE48A138C	2	1469 §		T-7608011 P107			C-489
X	C-490	NOT USED										
X	C-491	FIL. SUPPLY BY-PASS CAPACITOR	0.025 MFD. ±10%, 600 V.D.C. WORKING, MICA	48591-B10	RE48A154F RE48A221A	2 26	1445 LS § H2LW		T-7608011 P109			C-491, C-579
	C-492	NOT USED										
X	C-493	1ST DET. BAND 4 FIXED TRIMMER CAPACITOR	20 MMFD. ±5%, 500 V.D.C. WORKING, PAPER	48783-D5	RE48A149C RE48A154F	2	1469 §		T-7608011 P111			C-493, C-589
X	C-494	CV OSC. SCREEN FILTER CAPACITOR	SAME AS C-407	48848-B10								
X	C-495	COMPENSATOR FEEDBACK CAPACITOR	SAME AS C-464	481491-B5								
X	C-501	ANT. COMPENSATOR CAPACITOR	3 MMFD. TO 17 MMFD., VARIABLE AIR			6	ARL-23-0 SPECIAL		T-7607868 P5			C-501
	C-502	NOT USED										
	C-503	NOT USED										
X	C-504	ANT. STAGE TRACKING CAPACITOR	SAME AS C-491	48591-B10								C-504, C-505, C-518
X	C-505	1ST DET. GRID TRACKING CAPACITOR	SAME AS C-491	48591-B10								
X	C-506	ANT. COUPLING CAPACITOR BAND 1	SAME AS C-403	48771-B20								
X	C-507	R.F. A.V.C. BY-PASS CAPACITOR	SAME AS C-407	48848-B10								

§ WHEN ORDERING INCLUDE CAPACITY AND VOLTAGE.

P-7713092

TABLE 11 (CONTINUED)

PARTS AND SPARE PARTS LIST BY SYMBOL DESIGNATION FOR RBM-5 SEMI-PORTABLE RADIO RECEIVER EQUIPMENT

SPARE PARTS

BATTERY OR 60 CY. A.C. SUPPLY	SYMBOL DESIG.	FUNCTION	DESCRIPTION	NAVY TYPE NUMBER	NAVY SPEC. OR DRAWING NUMBER	MFR.	MFR. DESIG.	SPECIAL TOL. RATING OR MODIFICATION	CONTRACTOR'S DRAWING AND PART NUMBER	BOX NUMBER	QUANTITY	SPARE PARTS
												ALL SYMBOL DESIGNATIONS INVOLVED
CAPACITORS (CLASS 48) CONTINUED												
X	C-508	R.F. GRID BAND 4 TRIMMER CAPACITOR	SAME AS C-408									
X	C-509	R.F. GRID BAND 3 TRIMMER CAPACITOR	SAME AS C-408									
X	C-510	R.F. GRID BAND 2 TRIMMER CAPACITOR	SAME AS C-408									
X	C-511	R.F. GRID BAND 1 TRIMMER CAPACITOR	SAME AS C-408									
X	C-512A	R.F. GRID MAIN TUNING CAPACITOR	SAME AS C-412A									
X	C-512B	R.F. PLATE MAIN TUNING CAPACITOR	PART OF C-512A									
X	C-512C	1ST DET. GRID MAIN TUNING CAPACITOR	PART OF C-512A									
X	C-512D	OSCILLATOR MAIN TUNING CAPACITOR	PART OF C-512A									
X	C-513A	R.F. CATHODE BY-PASS CAPACITOR	SAME AS C-413A		482057-10							
X	C-513B	R.F. SCREEN BY-PASS CAPACITOR	(0.1 MFD.) PART OF C-513A									
X	C-514	R.F. PLATE BAND 4 TRIMMER CAPACITOR	SAME AS C-408									
X	C-515	R.F. PLATE BAND 3 TRIMMER CAPACITOR	SAME AS C-408									
X	C-516	R.F. PLATE BAND 2 TRIMMER CAPACITOR	SAME AS C-408									
X	C-517	R.F. PLATE BAND 1 TRIMMER CAPACITOR	SAME AS C-408									
X	C-518	R.F. PLATE FILTER CAPACITOR	SAME AS C-491		48591-B10							
X	C-519	1ST DET. GRID BAND 4 TRIMMER CAPACITOR	SAME AS C-408									
X	C-520	1ST DET. GRID BAND 3 TRIMMER CAPACITOR	SAME AS C-408									
X	C-521	1ST DET. GRID BAND 2 TRIMMER CAPACITOR	SAME AS C-408									
X	C-522	1ST DET. GRID BAND 1 TRIMMER CAPACITOR	SAME AS C-408									

6-01

TABLE II (CONTINUED)										SPARE PARTS		
PARTS AND SPARE PARTS LIST BY SYMBOL DESIGNATION FOR RBM-5 SEMI-PORTABLE RADIO RECEIVER EQUIPMENT												
BATTERY OR GO CY. A.C. SUPPLY	SYMBOL DESIG.	FUNCTION	DESCRIPTION	NAVY TYPE NUMBER	NAVY SPEC. OR DRAWING NUMBER	MFR.	MFR. DESIG.	SPECIAL TOL. RATING OR MODIFICATION	CONTRACTOR'S DRAWING AND PART NUMBER	BOX NUMBER	QUANTITY	ALL SYMBOL DESIGNATIONS INVOLVED
CAPACITORS (CLASS 48) CONTINUED												
X	C-523	R.F. GRID COUPLING CAPACITOR	SAME AS C-423	-48674-B10								
X	C-524	DET. SCREEN BY-PASS CAPACITOR	0.5 MFD., 600 V.D.C. WORKING, PAPER	-482059		2			T-7605996 P37			C-524
X	C-525	OSC. BAND 1 SERIES TRACKING CAPACITOR	380 MMFD. $\pm 1\%$, 500 V.D.C. WORKING, MICA	-481492-D1	RE48A148C RE48A154F	2	1469 S		T-7608012 P173			C-525
X	C-526	OSC. BAND 2 SERIES TRACKING CAPACITOR	640 MMFD. $\pm 1\%$, 300 V.D.C. WORKING, MICA	-481493-D1	RE48A148C RE48A154F	2	1469 S		T-7608012 P174			C-526
X	C-527	OSC. BAND 3 SERIES TRACKING CAPACITOR	1020 MMFD. $\pm 1\%$, 500 V.D.C. WORKING, MICA	-481494-D1	RE48A148C RE48A154F	2	1464 S		T-7608012 P175			C-527
X	C-528	OSC. BAND 4 SERIES TRACKING CAPACITOR	1350 MMFD. $\pm 1\%$, 500 V.D.C. WORKING, MICA	-481495-D1	RE48A148C RE48A154F	2	1464 S		T-7608012 P176			C-528
X	C-529	OSC. BAND 4 COMPENSATOR CAPACITOR	50 MMFD. $\pm 5\%$, 0.00015 MMF/MMF/°C.	-481457-5		4	CLASS D		T-7608012 P177			C-529
X	C-530	OSC. BAND 3 COMPENSATOR CAPACITOR	20 MMFD. $\pm 5\%$, 0.00025 MMF/MMF/°C. $\pm 15\%$, CERAMIC	-481454-5		4	CLASS D		T-7608012 P178			C-530
X	C-531	OSC. BAND 4 COMPENSATOR CAPACITOR	25 MMFD. $\pm 5\%$, 0.00015 MMF/MMF/°C. $\pm 20\%$, CERAMIC	-481455-5		4	CLASS D		T-7608012 P179			C-531
X	C-532	OSC. BAND 1 COMPENSATOR CAPACITOR	SAME AS C-432	-481456-5								
X	C-533	OSC. BAND 4 TRIMMER CAPACITOR	SAME AS C-408									
X	C-534	OSC. BAND 3 TRIMMER CAPACITOR	SAME AS C-408									
X	C-535	OSC. BAND 2 TRIMMER CAPACITOR	SAME AS C-408									
X	C-536	OSC. BAND 1 TRIMMER CAPACITOR	SAME AS C-408									
X	C-537	OSC. GRID COUPLING CAPACITOR	SAME AS C-423	-48674-B10								
X	C-538	OSC. 1ST DET. COUPLING CAPACITOR	SAME AS C-407	-48848-B10								
X	C-539A	OSC. SCREEN BY-PASS CAPACITOR	SAME AS C-439A	-481925								
X	C-539B	OSC. PLATE BY-PASS CAPACITOR	PART OF C-539A									
X	C-539C	1ST DET. PLATE BY-PASS CAPACITOR	PART OF C-539A									

WHEN ORDERING, INCLUDE CAPACITY AND VOLTAGE.

TABLE II (CONTINUED)

PARTS AND SPARE PARTS LIST BY SYMBOL DESIGNATION FOR RBM-5 SEMI-PORTABLE RADIO RECEIVER EQUIPMENT

SPARE PARTS

BATTERY OR 60 CY. A.C. SUPPLY	SYMBOL DESIG.	FUNCTION	DESCRIPTION	NAVY TYPE NUMBER	NAVY SPEC. OR DRAWING NUMBER	MFR.	MFR. DESIG.	SPECIAL TOL. RATING OR MODIFICATION	CONTRACTOR'S DRAWING AND PART NUMBER	BOX NUMBER	QUANTITY	ALL SYMBOL DESIGNATIONS INVOLVED
X	C-540A	1ST I.F. PRI. TRIMMER CAPACITOR	SAME AS C-440A									
X	C-540B	1ST I.F. SEC. TRIMMER CAPACITOR	PART OF C-540A									
X	C-541	1ST I.F. PRI. FIXED TRIMMER CAPACITOR	120 MFD. $\pm 3\%$, 500 V.D.C. WORKING, MICA	481496-D3	RE48A148C RE48A154F	2			T-7608012 P192			C-541, C-542, C-545 C-547, C-552, C-553
X	C-542	1ST I.F. SEC. FIXED CAPACITOR	SAME AS C-541	481496-D3								
X	C-543	1ST I.F. A.V.C. BY-PASS CAPACITOR	SAME AS C-407	48848-B10								
X	C-544A	1ST I.F. SCREEN BY-PASS CAPACITOR	SAME AS C-444A	481466								
X	C-544B	1ST I.F. PLATE BY-PASS CAPACITOR	PART OF C-544A									
X	C-544C	1ST I.F. CATHODE BY-PASS CAPACITOR	PART OF C-544A									
X	C-545A	2ND I.F. PRI. TRIMMER CAPACITOR	SAME AS C-440A									
X	C-545B	2ND I.F. SEC. TRIMMER CAPACITOR	PART OF C-545A									
X	C-546	2ND I.F. PRI. FIXED TRIMMER CAPACITOR	SAME AS C-541	481496-D3								
X	C-547	2ND I.F. SEC. FIXED TRIMMER CAPACITOR	SAME AS C-541	481496-D3								
X	C-548	1ST DET. A.V.C. BY-PASS CAPACITOR	SAME AS C-407	48848-B10								
X	C-549A	2ND I.F. SCREEN BY-PASS CAPACITOR	SAME AS C-444A	481466								
X	C-549B	2ND I.F. PLATE BY-PASS CAPACITOR	PART OF C-549A									
X	C-549C	2ND I.F. CATHODE BY-PASS CAPACITOR	PART OF C-549A									
X	C-550A	1ST A.F. CATHODE FILTER CAPACITOR	SAME AS C-413A	482057-10								
X	C-550B	1ST A.F. SCREEN BY-PASS CAPACITOR	(0.1 MFD.) PART OF C-550A									
X	C-551A	3RD I.F. PRI. TRIMMER CAPACITOR	SAME AS C-440A									

TABLE 11 (CONTINUED)

PARTS AND SPARE PARTS LIST BY SYMBOL DESIGNATION FOR RBM-5 SEMI-PORTABLE RADIO RECEIVER EQUIPMENT

BATTERY OR 60 CY. A.C. SUPPLY	SYMBOL DESIG.	FUNCTION	DESCRIPTION	NAVY TYPE NUMBER	NAVY SPEC. OR DRAWING NUMBER	MFR.	MFR. DESIG.	SPECIAL TOL. RATING OR MODIFICATION	CONTRACTOR'S DRAWING AND PART NUMBER	BOX NUMBER	QUANTITY	SPARE PARTS
												ALL SYMBOL DESIGNATIONS INVOLVED
CAPACITORS (CLASS 48) CONTINUED												
X	C-551B	3RD I.F. SEC. TRIMMER CAPACITOR	PART OF C-551A									
X	C-552	3RD I.F. PRI. FIXED TRIMMER CAPACITOR	SAME AS C-541	-481496-D3								
X	C-553	3RD I.F. SEC. FIXED TRIMMER CAPACITOR	SAME AS C-541	-481496-D3								
X	C-554	SIGNAL DIODE FILTER CAPACITOR	SAME AS C-402	-48895-B10								
X	C-555	SIGNAL DIODE FILTER CAPACITOR	SAME AS C-402	-48895-B10								
X	C-556	A.V.C. DIODE COUPLING CAPACITOR	SAME AS C-423	-48674-B10								
X	C-557	VOLUME CONTROL COUPLING CAPACITOR	SAME AS C-407	-48848-B10								
X	C-558A	1ST A.F. PLATE FILTER CAPACITOR	SAME AS C-413A	-482057-10								
X	C-558B	2ND A.F. PLATE & SCREEN FILTER CAPACITOR	(0.1 MFD.) PART OF C-558A									
X	C-559	A.V.C. FILTER CAPACITOR	SAME AS C-407	-48848-B10								
X	C-560A	2ND A.F. SCREEN BY-PASS CAPACITOR	SAME AS C-460A	-482058-10								
X	C-560B	3RD A.F. PLATE & SCREEN FILTER CAPACITOR	(0.5 MFD.) PART OF C-560A									
X	C-561	PEAK LIMITER LOAD BY-PASS CAPACITOR	SAME AS C-407	-48848-B10								
X	C-562	FEED BACK COUPLING CAPACITOR	SAME AS C-462	-481469								
X	C-563	1ST A.F. PLATE BY-PASS CAPACITOR	SAME AS C-463	-481490-B5								
X	C-564	LOW PASS FILTER CAPACITOR	SAME AS C-464	-481491-B5								
X	C-565	LOW PASS FILTER CAPACITOR	SAME AS C-463	-481490-B5								
X	C-566	3RD A.F. GRID COUPLING CAPACITOR	SAME AS C-407	-48848-B10								
X	C-587	CW OSC. COUPLING CAPACITOR	3.5 MFD. \pm 0.5 MFD., 500 V.D.C. WORKING, MICA	-481497- B14	RE48A148C RE48A154F	2	1468 LS §		T-7608013 P226			C-567
X	C-568A	CW OSC. B+ BY-PASS CAPACITOR	SAME AS C-444A	-481466								

§ WHEN ORDERING, INCLUDE CAPACITY AND VOLTAGE.

P-7713092

TABLE II (CONTINUED)										SPARE PARTS		
PARTS AND SPARE PARTS LIST BY SYMBOL DESIGNATION FOR RBM-5 SEMI-PORTABLE RADIO RECEIVER EQUIPMENT												
BATTERY OR GO CY. A.C. SUPPLY	SYMBOL DESIG.	FUNCTION	DESCRIPTION	NAVY TYPE NUMBER	NAVY SPEC. OR DRAWING NUMBER	MFR.	MFR. DESIG.	SPECIAL TOL. RATING OR MODIFICATION	CONTRACTOR'S DRAWING AND PART NUMBER	BOX NUMBER	QUANTITY	ALL SYMBOL DESIGNATIONS INVOLVED
	CAPACITORS (CLASS 48) CONTINUED											
X	C-568B	CW OSC. PLATE FILTER CAPACITOR	PART OF C-568A									
X	C-568C	CW OSC. HEATER BY-PASS CAPACITOR	PART OF C-568A									
X	C-569	2ND I.F. GRID COUPLING CAPACITOR	SAME AS C-423	-48674-B10								
X	C-570	CW OSC. GRID COUPLING CAPACITOR	SAME AS C-423	-48674-B10								
X	C-571	CW OSC. FIXED TRIMMER CAPACITOR	195 MMFD. $\pm 5\%$, 500 V.D.C. WORKING, MICA	-481498-D3	RE48A148C RE48A154F	2	1469 §		T-7608013 P232			C-571
X	C-572	CW OSC. TRIMMER CAPACITOR	SAME AS C-472									
X	C-573	CW OSC. VERNIER CAPACITOR	2.1 ± 2 MMFD. CHANGE FROM MIN. TO MAX., VARIABLE AIR			6	ARL-0		T-7607868 P4			C-573
X	C-574	HIGH VOLTAGE BY-PASS CAPACITOR	SAME AS C-462	-481469								
X	C-575	SCREEN SUPPLY FILTER CAPACITOR	SAME AS C-475	-481470								
X	C-576	1ST A.F. GRID COUPLING CAPACITOR	SAME AS C-407	-48848-B10								
X	C-577	1ST DET. GRID COUPLING CAPACITOR	SAME AS C-423	-48674-B10								
X	C-578	1ST DET. GRID FIXED TRIMMER CAPACITOR	SAME AS C-483	-481480-10								
X	C-579	B+ BY-PASS CAPACITOR	SAME AS C-491	-48591-B10								
X	C-580	2ND A.F. GRID COUPLING CAPACITOR	SAME AS C-418	-481037- B10								
X	C-581	2-3 A.V.C. FILTER CAPACITOR	SAME AS C-407	-48848-B10								
X	C-582	1-2 A.V.C. FILTER CAPACITOR	SAME AS C-407	-48848-B10								
X	C-583	ANT. BAND 2 FIXED TRIMMER CAPACITOR	SAME AS C-486	-48771-D20								
X	C-584	ANT. BAND 3 FIXED TRIMMER CAPACITOR	SAME AS C-406	-48710-D10								
X	C-585	ANT. BAND 4 FIXED TRIMMER CAPACITOR	SAME AS C-406	-48710-D10								
X	C-586	R.F. PLATE BAND 1 FIXED TRIMMER CAPACITOR	SAME AS C-486	-48771-D20								

§ WHEN ORDERING, INCLUDE CAPACITY AND VOLTAGE.

TABLE II (CONTINUED)										SPARE PARTS		
PARTS AND SPARE PARTS LIST BY SYMBOL DESIGNATION FOR RBM-5 SEMI-PORTABLE RADIO RECEIVER EQUIPMENT												
BATTERY OR 60 CY. A.C. SUPPLY	SYMBOL DESIG.	FUNCTION	DESCRIPTION	NAVY TYPE NUMBER	NAVY SPEC. OR DRAWING NUMBER	MFR.	MFR. DESIG.	SPECIAL TOL. RATING OR MODIFICATION	CONTRACTOR'S DRAWING AND PART NUMBER	BOX NUMBER	QUANTITY	ALL SYMBOL DESIGNATIONS INVOLVED
X	C-587	R.F. PLATE BAND 2 FIXED TRIMMER CAPACITOR	SAME AS C-406	-48710-D10								
X	C-588	R.F. PLATE BAND 3 FIXED TRIMMER CAPACITOR	SAME AS C-479	-48840-D7								
X	C-589	R.F. PLATE BAND 4 FIXED TRIMMER CAPACITOR	SAME AS C-493	-48783-D5								
	C-590	NOT USED										
X	C-591	1ST DET. GRID BAND 2 FIXED TRIMMER CAPACITOR	SAME AS C-403	-48771-B20								
X	C-592	1ST DET. GRID BAND 3 FIXED TRIMMER CAPACITOR	SAME AS C-406	-48710-D10								
X	C-593	1ST DET. GRID BAND 4 FIXED TRIMMER CAPACITOR	SAME AS C-479	-48840-D7								
X	C-594	CW OSC. SCREEN FILTER CAPACITOR	SAME AS C-407	-48848-B10								
X	C-595	COMPENSATOR FEEDBACK CAPACITOR	SAME AS C-464	-481491-B5								
X	C-596	R.F. CATHODE CAPACITOR	SAME AS C-407	-48848-B10								
X	C-597	BY-PASS OSC. HEATER CAPACITOR	1000 MMFD. $\pm 10\%$, 300 V.D.C. WORKING, MICA	-481070-BX		2	1468LS \$		T-7608013 P258			C-597, C-598
X	C-598	BY-PASS OSC. SCREEN CAPACITOR	SAME AS C-597	-481070-B10								
X	C-601	FILTER DYN. L.V. CAPACITOR	2 MFD., 400 V.D.C. WORKING, PAPER	-481471	RE48AA129C	2		+10, -3%	T-7605996 P22			C-601, C-605
X	C-602	FILTER DYN. H.V. BRUSH CAPACITOR	690 MMFD. $\pm 5\%$, 500 V.D.C. WORKING, MICA (SAME AS C-464)	-481491-B5	RE48A148C RE48A154F	2 26	1468LS \$		T-7607845 P2	1	#	C-602
X	C-603	FILTER DYN. L.V. BRUSH CAPACITOR	0.01 MFD., $\pm 10\%$, 300 V.D.C. WORKING, MICA, (SAME AS C-407)	-48848-B10	RE48AA143F RE48A154F	2	1467LS \$		T-7607845 P3	1	#	C-603
X	C-604	H.V. FILTER CAPACITOR	4 MFD., 600 V.D.C. WORKING, PAPER, FOR REPLACEMENT, USE NAVY TYPE -481249		RE48AA110L	2			T-7605996 P23			C-604, C-606
X	C-605	DYN. L.V. FILTER CAPACITOR	SAME AS C-601	-481471								
X	C-606	H.F. FILTER CAPACITOR	SAME AS C-604									
X	C-901A	LINE FILTER CAPACITOR	SAME AS C-424A	-481465-10								C-901A, C-901B
X	C-901B	LINE FILTER CAPACITOR	A PART OF C-901A									

\$ WHEN ORDERING, INCLUDE CAPACITY AND VOLTAGE.

SUPPLIED IN SPARE SUB ASSEMBLIES D-601 OR D-602.

P-7713092

TABLE 11 (CONTINUED)

PARTS AND SPARE PARTS LIST BY SYMBOL DESIGNATION FOR RBM-5 SEMI-PORTABLE RADIO RECEIVER EQUIPMENT

BATTERY OR 50 CY. A.C. SUPPLY	SYMBOL DESIG.	FUNCTION	DESCRIPTION	NAVY TYPE NUMBER	NAVY SPEC. OR DRAWING NUMBER	MFR.	MFR. DESIG.	SPECIAL VOL. RATING OR MODIFICATION	CONTRACTOR'S DRAWING AND PART NUMBER	SPARE PARTS	
										BOX NUMBER	QUANTITY
	<u>CAPACITORS (CLASS 48) CONTINUED</u>										
X	C-902	REACTOR TUNING (60 CYCLE) CAPACITOR	0.35 MFD., 400 V.D.C. WORKING, PAPER	-481483	RE48AA129C	2	TYPE 430 §		T-7605996 P27		C-902
X	C-903	1ST H.V. (60 CYCLE) FILTER CAPACITOR	SAME AS C-604								C-903, C-904
X	C-904	2ND H.V. (60 CYCLE) FILTER CAPACITOR	SAME AS C-604								
X	C-1001A	LINE FILTER CAPACITOR	SAME AS C-424A	-481465-10							C-1001A, C-1001B
X	C-1001B	LINE FILTER CAPACITOR	PART OF C-1001A								
	<u>DYNAMOTORS (CLASS 21)</u>										
X	D-601	DYNAMOTOR	DYNAMOTOR ASSEMBLY OF SHOCKMOUNT, CAPACITORS & PLUG			1			P-7708216 G1	1	1 D-601, D-602
X	D-601A	DYNAMOTOR	INPUT, 12 V., 3 AMPS., OUTPUT 235 V., .075 AMP.	-21772		1			P-7708217 G1	1	◇ D-601A
X	D-602	DYNAMOTOR	SAME AS D-601							1	
	<u>MISCELLANEOUS (CLASS 10)</u>										
X	E-601	DYNAMOTOR BRUSH	FOR D-601 & D-602			1			T-7607845 P12	1	4 SET E-601
	<u>FUSES (CLASS 28)</u>										
X	F-601A	C.F.I. LOW VOLTAGE FUSE	5 AMPS., 25 VOLTS			15 25	SAG #1080 SAG5		T-7607845 P13	1	2 F-601A
X	F-601B	FUSE HOLDER FOR F-601A	EXTRACTOR TYPE			25	TYPE HKM		T-7607845 P14		F-601B, F-602B, F-603B, F-604B, F-605B, F-606B
X	F-602A	C.F.I. HIGH VOLTAGE FUSE	0.25 AMP., 250 VOLTS			15 25	SAG #1045 SAG-1/4		T-7607845 P15	1	6 F-602A, F-604A, F-606A
X	F-602B	FUSE HOLDER FOR F-602A	SAME AS F-601B			2					
X	F-603A	H.F. RECEIVER LOW VOLTAGE FUSE	15 AMPS., 25 VOLTS			15 25	SAG #1082 SAG15		T-7607845 P17	1	4 F-603A, F-605A
X	F-603B	FUSE HOLDER FOR F-603A	SAME AS F-601B								
X	F-604A	H.F. RECEIVER HIGH VOLTAGE FUSE	SAME AS F-602A							1	

◇ SUPPLIED IN SPARE SUB ASSEMBLIES D-601 OR D-602.

§ WHEN ORDERING, INCLUDE CAPACITY AND VOLTAGE.

P-7713092

10-15

TABLE II (CONTINUED)

PARTS AND SPARE PARTS LIST BY SYMBOL DESIGNATION FOR RBM-5 SEMI-PORTABLE RADIO RECEIVER EQUIPMENT

BATTERY OR 60 CY. A.C. SUPPLY	SYMBOL DESIG.	FUNCTION	DESCRIPTION	NAVY TYPE NUMBER	NAVY SPEC. OR DRAWING NUMBER	MFR.	MFR. DESIG.	SPECIAL TOL. RATING OR MODIFICATION	CONTRACTOR'S DRAWING AND PART NUMBER	SPARE PARTS	
										BOX NUMBER	QUANTITY
FUSES (CLASS 28) CONTINUED											
X	F-604B	FUSE HOLDER FOR F-604A	SAME AS F-601B								
X	F-605A	M.F. RECEIVER LOW VOLTAGE FUSE	SAME AS F-603A							1	
X	F-605B	FUSE HOLDER FOR F-605A	SAME AS F-601B								
X	F-606A	M.F. RECEIVER HIGH VOLTAGE FUSE	SAME AS F-602A							1	
X	F-606B	FUSE HOLDER FOR F-606A	SAME AS F-601B								
X	F-901A	LINE FUSE	2 AMPS., 250 VOLTS, EXTRACTOR TYPE			15 25	3AG-1042 3AG2		T-7607915 P19		F-901A, F-902A
X	F-901B	FUSE HOLDER FOR F-901A	SAME AS F-601B								F-901B, F-902B, F-1001B, F-1002B
X	F-902A	LINE FUSE	SAME AS F-901A								
X	F-902B	FUSE HOLDER FOR F-902A	SAME AS F-601B								
X	F-1001A	LINE FUSE	0.75 AMP., 250 VOLTS			15 25	3AG #1047 3AG-3/4		T-7607921 P5		F-1001A, F-1002A
X	F-1001B	FUSE HOLDER FOR F-1001A	SAME AS F-601B								
X	F-1002A	LINE FUSE	SAME AS F-1001A								
X	F-1002B	FUSE HOLDER FOR F-1002A	SAME AS F-601B								
<u>MISCELLANEOUS (CLASS 10)</u>											
X	I-401	M.F. RECEIVER DIAL LAMP	12 TO 16 VOLTS, T-3-1/4 BULB, 0.2 AMP., PANEL LAMP, MINIATURE BAYONET BASE			1			T-7608014 P289	1	I-401, I-402, I-501, I-502, I-601
X	I-402	M.F. RECEIVER DIAL LAMP	SAME AS I-401							1	
X	I-501	H.F. RECEIVER DIAL LAMP	SAME AS I-401							1	
X	I-502	H.F. RECEIVER DIAL LAMP	SAME AS I-401							1	
X	I-601	PANEL LAMP	SAME AS I-401							1	
X	I-901A	A.C. POWER SUPPLY INDICATOR LAMP	SAME AS I-401								I-901A, I-1001A, I-1002A, I-1003A
X	I-901B	A.C. POWER SUPPLY INDICATOR RECEPTACLE	REMOVABLE BEZEL MINIATURE BAYONET SOCKET			21	TYPE 50 RUBY LENS		P-7708330 P1		I-901B, I-1001B, I-1002B, I-1003B
X	I-1001A	M.F. POWER INDICATOR LAMP	SAME AS I-401								

10-16

P-7713092

TABLE II. (CONTINUED)

PARTS AND SPARE PARTS LIST BY SYMBOL DESIGNATION FOR RBM-5 SEMI-PORTABLE RADIO RECEIVER EQUIPMENT

SPARE PARTS

BATTERY OR 60 CY. A.C. SUPPLY	SYMBOL DESIG.	FUNCTION	DESCRIPTION	NAVY TYPE NUMBER	NAVY SPEC. OR DRAWING NUMBER	MFR.	MFR. DESIG.	SPECIAL TOL. RATING OR MODIFICATION	CONTRACTOR'S DRAWING AND PART NUMBER	BOX NUMBER	QUANTITY	ALL SYMBOL DESIGNATIONS INVOLVED
X	I-1001B	M.F. POWER INDICATOR LAMP RECEPTACLE	SAME AS I-901B									
X	I-1002A	MAIN POWER INDICATOR LAMP	SAME AS I-401									
X	I-1002B	MAIN POWER INDICATOR LAMP RECEPTACLE	SAME AS I-901B									
X	I-1003A	H.F. POWER INDICATOR LAMP	SAME AS I-401									
X	I-1003B	H.F. POWER INDICATOR LAMP RECEPTACLE	SAME AS I-901B									
<u>JACKS AND RECEPTACLES (CLASS 49)</u>												
X	J-401	M.F. RECEIVER ANTENNA POST	BINDING POST TYPE						M-7408081 G1			J-401, J-501
X	J-402	M.F. RECEIVER GROUND POST	BINDING POST TYPE						P-7707734 P17			J-402, J-502
X	J-403	M.F. RECEIVER PHONE JACK	SINGLE CIRCUIT	-49025B			TC-75		P-7706766 P7			J-403, J-503, J-601, J-602
X	J-404	2ND DET. OUTPUT TERMINAL BOARD	TWO TERMINALS, LINK CONNECTED						M-7407735 G1			J-404, J-504
X	J-405	M.F. POWER RECEPTACLE	8 CONTACT	-49043					T-7607968 G3			J-405, J-505, J-606, J-607
X	J-405A	FILLER FOR J-405	CONTACT & PANEL ASSEMBLY FOR J-405						T-7607968 G6			J-405A, J-505A, J-606A, J-607A
X	J-501	H.F. RECEIVER ANTENNA POST	SAME AS J-401									
X	J-502	H.F. RECEIVER GROUND POST	SAME AS J-402									
X	J-503	H.F. RECEIVER PHONE JACK	SAME AS J-403	-49025B								
X	J-504	2ND DET. OUTPUT TERMINAL BOARD	SAME AS J-404									
X	J-505	H.F. POWER RECEPTACLE	SAME AS J-405	-49043								
X	J-505A	FILLER FOR J-505	SAME AS J-405A									
X	J-601	I.F. SIDETONE JACK	SAME AS J-403	-49025B								
X	J-602	H.F. SIDETONE JACK	SAME AS J-403	-49025B								
X	J-603	DYNAMOTOR SOCKET	3 CIRCUIT, FEMALE	-49179			S-303-4B		M-7408053 P2			J-603, J-604
X	J-604	DYNAMOTOR SOCKET	SAME AS J-603	-49179								

TABLE II (CONTINUED)

PARTS AND SPARE PARTS LIST BY SYMBOL DESIGNATION FOR RBM-5 SEMI-PORTABLE RADIO RECEIVER EQUIPMENT

SPARE PARTS

BATTERY OR GO CT. A.C SUPPLY	SYMBOL DESIG.	FUNCTION	DESCRIPTION	NAVY TYPE NUMBER	NAVY SPEC. OR DRAWING NUMBER	MFR. MFR.	MFR. DESIG.	SPECIAL TOL. RATING OR MODIFICATION	CONTRACTOR'S DRAWING AND PART NUMBER	BOX NUMBER	QUANTITY	ALL SYMBOL DESIGNATIONS INVOLVED
X	J-605	C.F.I. RECEPTACLE	5 CONTACT	-49036		17						J-605
X	J-605A	RECEPTACLE FILLER FOR J-605	PANEL AND CONTACT ASSEMBLY			17						J-605A
X	J-606	H.F. RECEIVER POWER RECEPTACLE	SAME AS J-405	-49043								
X	J-606A	RECEPTACLE FILLER FOR J-606	SAME AS J-405A									
X	J-607	H.F. RECEIVER POWER RECEPTACLE	SAME AS J-405	-49043								
X	J-607A	RECEPTACLE FILLER FOR J-607	SAME AS J-405A									
X	J-608	BATTERY RECEPTACLE	4 CONTACT	-49055		17						J-608, J-609
X	J-608A	RECEPTACLE FILLER FOR J-608	PANEL & CONTACT ASSEMBLY			17						J-608A, J-609A
X	J-609	GENERATOR RECEPTACLE	SAME AS J-608	-49055								
X	J-609A	RECEPTACLE FILLER FOR J-609	SAME AS J-608A									
X	J-901	A.C. LINE PLUG	FLUSH MOUNTING MALE PLUG			14	#61-M10					J-901, J-1002
X	J-902	C.F.I. RECEPTACLE	SAME AS J-605	-49036								J-902, J-1008
X	J-902A	RECEPTACLE FILLER FOR J-902	SAME AS J-605A									J-902A
X	J-903	POWER OUTPUT RECEPTACLE	SAME AS J-405	-49043								J-903, J-1006, J-1010
X	J-903A	RECEPTACLE FILLER FOR J-903	SAME AS J-405A									J-903A, J-1006A, J-1010A
X	J-1001	M.F. LINE RECEPTACLE	FLUSH MOUNTING, FEMALE			14	61F1					J-1001, J-1003
X	J-1002	A.C. LINE RECEPTACLE	SAME AS J-901									
X	J-1003	H.F. LINE RECEPTACLE	SAME AS J-1001									
X	J-1004	I.F. SIDETONE JACK	SAME AS J-403	-49025B								J-1004, J-1005
X	J-1005	H.F. SIDETONE JACK	SAME AS J-403	-49025B								
X	J-1006	POWER TO M.F. RECEIVER RECEPTACLE	SAME AS J-405	-49043								
X	J-1006A	RECEPTACLE FILLER FOR J-1006	SAME AS J-405A									

TABLE II (CONTINUED)										SPARE PARTS		
PARTS AND SPARE PARTS LIST BY SYMBOL DESIGNATION FOR RBM-S SEMI-PORTABLE RADIO RECEIVER EQUIPMENT												
BATTERY OR 60 CY. A.C. SUPPLY	SYMBOL DESIG.	FUNCTION	DESCRIPTION	NAVY TYPE NUMBER	NAVY SPEC. OR DRAWING NUMBER	QTY.	MFR. DESIG.	SPECIAL TOL. RATING OR MODIFICATION	CONTRACTOR'S DRAWING AND PART NUMBER	BOX NUMBER	QUANTITY	ALL SYMBOL DESIGNATIONS INVOLVED
<u>JACKS AND RECEPTACLES (CLASS 49) CONTINUED</u>												
X	J-1007	M.F. POWER RECEPTACLE	SAME AS J-608	-49053								J-1007, J-1009
X	J-1007A	RECEPTACLE FILLER FOR J-1007	SAME AS J-608A									J-1007A, J-1009A
X	J-1008	C.F.I. RECEPTACLE	SAME AS J-606	-49036								J-1008A
X	J-1008A	RECEPTACLE FILLER FOR J-1008	SAME AS J-605A									
X	J-1009	H.F. POWER RECEPTACLE	SAME AS J-608	-49053								
X	J-1009A	RECEPTACLE FILLER FOR J-1009	SAME AS J-608A									
X	J-1010	POWER TO H.F. RECEIVER RECEPTACLE	SAME AS J-405	-49043								
X	J-1010A	RECEPTACLE FILLER FOR J-1010	SAME AS J-405A									
X	J-1301	BATTERY/RECEPTACLE	3 CONTACT, MALE	-49169		5	WK-C3-32SL		P-7708334 P1			J-1301, J-1302
X	J-1302	BATTERY RECEPTACLE	SAME AS J-1301	-49169								
<u>RELAYS (CLASS 29)</u>												
X	K-601	C.F.I. HIGH VOLTAGE SWITCHING RELAY	S.P.D.T., COIL 6500 TURNS OF #33 E.C. WIRE, RESISTANCE 250 OHMS COIL TO OPERATE ON 10 TO 15 VOLTS			18	#A-10159 TYPE G. COIL W4-1020-5		P-7708260 P1			K-601
X	K-1001	C.F.I. H.V. TRANSFER RELAY	S.P.D.T., 115 VOLTS, 60 CYCLE A.C. COIL 4000 TURNS #31 FORMEX WIRE, RESISTANCE 100 OHMS, COIL TO OPERATE ON 100 TO 130 VOLTS			18	#A-10315 TYPE A. COIL W5-1008		P-7708260 P2			K-1001
<u>REACTORS (CLASS 30 AND COILS AND INDUCTORS (CLASS 47))</u>												
X	L-401	ANTENNA COIL BAND 4	UNIVERSAL WOUND			1			T-7607404 P4			L-401
X	L-402	ANTENNA COIL BAND 3	UNIVERSAL WOUND - IRON CORE			1			T-7607404 P5			L-402
X	L-403	ANTENNA COIL BAND 2	UNIVERSAL WOUND - IRON CORE			1			T-7607404 P2			L-403
X	L-404	ANTENNA COIL BAND 1	UNIVERSAL WOUND - IRON CORE			1			T-7607404 P1			L-404
X	L-405	R.F. PLATE COIL BAND 4	UNIVERSAL WOUND			1			T-7607404 P8			L-405
X	L-406	R.F. PLATE COIL BAND 3	UNIVERSAL WOUND			1			T-7607404 P7			L-406

TABLE II (CONTINUED)

PARTS AND SPARE PARTS LIST BY SYMBOL DESIGNATION FOR RBM-5 SEMI-PORTABLE RADIO RECEIVER EQUIPMENT										SPARE PARTS	
BATTERY OR 60 CY. A.C. SUPPLY	SYMBOL DESIG.	FUNCTION	DESCRIPTION	NAVY TYPE NUMBER	NAVY SPEC. OR DRAWING NUMBER	MFR. DESIG.	SPECIAL TOL. RATING OR MODIFICATION	CONTRACTOR'S DRAWING AND PART NUMBER	BOX NUMBER	QUANTITY	ALL SYMBOL DESIGNATIONS INVOLVED
	REACTORS (CLASS 30) AND COILS AND INDUCTORS (CLASS 47) CONTINUED										
X	L-407	R.F. PLATE COIL BAND 2	UNIVERSAL WOUND					T-7607404 P8		1	L-407
X	L-408	R.F. PLATE COIL BAND 1	UNIVERSAL WOUND					T-7607404 P5		1	L-408
X	L-409	1ST DET. GRID COIL BAND 4	UNIVERSAL WOUND					T-7607404 P12		1	L-409
X	L-410	3ST DET. GRID COIL BAND 3	UNIVERSAL WOUND					T-7607404 P11		1	L-410
X	L-411	1ST DET. GRID COIL BAND 2	UNIVERSAL WOUND					T-7607404 P10		1	L-411
X	L-412	1ST DET. GRID COIL BAND 1	UNIVERSAL WOUND					T-7607404 P9		1	L-412
X	L-413	1ST OSC. COIL BAND 4	SOLENOID WOUND					T-7607404 P16		1	L-413
X	L-414	1ST OSC. COIL BAND 3	UNIVERSAL WOUND					T-7607404 P15		1	L-414
X	L-415	1ST OSC. COIL BAND 2	UNIVERSAL WOUND					T-7607404 P14		1	L-415
X	L-416	1ST OSC. COIL BAND 1	UNIVERSAL WOUND					T-7607404 P13		1	L-416
X	L-417	1ST I.F. COIL	UNIVERSAL WOUND					T-7607404 P18		1	L-417
X	L-418	2ND I.F. COIL	UNIVERSAL WOUND					T-7607404 P19		1	L-418
X	L-419	3RD I.F. COIL	UNIVERSAL WOUND					T-7607404 P20		1	L-419
X	L-420	CW OSC. COIL	UNIVERSAL WOUND					T-7607404 P17		1	L-420
X	L-421	LOW PASS FILTER REACTOR	IRON CORE, 7.5 HENRIES					L-382520		1	L-421, L-422, L-521, L-522
X	L-422	LOW PASS FILTER REACTOR	SAME AS L-421								
X	L-423	WAVE TRAP COIL	UNIVERSAL WINDING, ADJUSTABLE IRON CORE					T-7607404 P21		1	L-423
X	L-501	ANTENNA COIL BAND 4	SOLENOID WINDING					T-7607405 P4		1	L-501
X	L-502	ANTENNA COIL BAND 3	SOLENOID WINDING					T-7607405 P3		1	L-502
X	L-503	ANTENNA COIL BAND 2	SOLENOID WINDING					T-7607405 P2		1	L-503
X	L-504	ANTENNA COIL BAND 1	UNIVERSAL WINDING					T-7607405 P1		1	L-504
X	L-505	R.F. PLATE COIL BAND 4	SOLENOID WINDING					T-7607405 P8		1	L-505
X	L-506	R.F. PLATE COIL BAND 3	SOLENOID WINDING					T-7607405 P7		1	L-506
X	L-507	R.F. PLATE COIL BAND 2	SOLENOID WINDING PRIMARY, UNIVERSAL WINDING SECONDARY					T-7607405 P6		1	L-507
X	L-508	R.F. PLATE COIL BAND 1	SOLENOID WINDING PRIMARY, UNIVERSAL WINDING SECONDARY					T-7607405 P5		1	L-508
X	L-509	1ST DET. GRID COIL BAND 4	SOLENOID WINDING					T-7607405 P12		1	L-509

08-01

TABLE 11 (CONTINUED)

PARTS AND SPARE PARTS LIST BY SYMBOL DESIGNATION FOR RBM-5 SEMI-PORTABLE RADIO RECEIVER EQUIPMENT											SPARE PARTS	
BATTERY OR 60 CY. A.C. SUPPLY	SYMBOL DESIG.	FUNCTION	DESCRIPTION	NAVY TYPE NUMBER	NAVY SPEC. OR DRAWING NUMBER	MFR.	MFR. DESIG.	SPECIAL TOL. RATING OR MODIFICATION	CONTRACTOR'S DRAWING AND PART NUMBER	BOX NUMBER	QUANTITY	ALL SYMBOL DESIGNATIONS INVOLVED
	REACTORS (CLASS 30) AND COILS AND INDUCTORS (CLASS 47) CONTINUED											
X	L-510	1ST DET. GRID COIL BAND 3	SOLENOID WINDING						T-7607405 P11			L-510
X	L-511	1ST DET. GRID COIL BAND 2	SOLENOID WOUND PRIMARY UNIVERSAL WOUND SECONDARY						T-7607405 P10			L-511
X	L-512	1ST DET. GRID COIL BAND 1	SOLENOID WOUND PRIMARY UNIVERSAL WOUND SECONDARY						T-7607405 P9			L-512
X	L-513	1ST OSC. COIL BAND 4	SOLENOID WINDING						T-7607405 P16			L-513
X	L-514	1ST OSC. COIL BAND 3	SOLENOID WINDING						T-7607415 P15			L-514
X	L-515	1ST OSC. COIL BAND 2	SOLENOID WINDING						T-7607405 P14			L-515
X	L-516	1ST OSC. COIL BAND 1	SOLENOID WINDING						T-7607405 P13			L-516
X	L-517	1ST I.F. COIL	UNIVERSAL WINDING						T-7607405 P18			L-517
X	L-518	2ND I.F. COIL	UNIVERSAL WINDING						T-7607405 P19			L-518
X	L-519	3RD I.F. COIL	UNIVERSAL WINDING						T-7607405 P20			L-519
X	L-520	CW OSC. COIL	UNIVERSAL WINDING						T-7607405 P17			L-520
X	L-521	LOW PASS FILTER REACTOR	SAME AS L-421									
X	L-522	LOW PASS FILTER REACTOR	SAME AS L-421									
X	L-601	R.F. CHOKE	42 INCHES OF #14 ENAMELLED COPPER WIRE COIL FORM 2-7/8" OF 1/2" OUTSIDE DIAMETER						P-7708329 C1			L-601, L-603
X	L-602	FILTER REACTOR	3500 TURNS OF #34 ENAMELLED COPPER WIRE, 4 HENRIES D.C. RESISTANCE 280 OHMS ±10%	-30816					L-382519			L-602, L-604
X	L-603	FILTER REACTOR	SAME AS L-601									
X	L-604	FILTER REACTOR	SAME AS L-602	-30816								
X	L-901	FILTER REACTOR	2500 TURNS OF #30 ENAMELLED COPPER WIRE, 5 HENRIES, 250 VOLTS, D.C. RESISTANCE 108 OHMS ±15%	-30818					L-382522			L-901, L-902
X	L-902	FILTER REACTOR	SAME AS L-901	-30818								
			<u>METERS (CLASS 22)</u>									
X	M-601	INPUT VOLTMETER	0 TO 15 V.D.C., 1000 OHMS PER VOLT, 2-1/2" FLUSH BAKELITE CASE	MR25B 015DCVV					M-7409887 P7			M-601

TABLE 11 (CONTINUED)

PARTS AND SPARE PARTS LIST BY SYMBOL DESIGNATION FOR ~~SEM-5~~ SEMI-PORTABLE RADIO RECEIVER EQUIPMENT

BATTERY OR 50 CY. A.C. SUPPLY	SYMBOL DESIG.	FUNCTION	DESCRIPTION	NAVY TYPE NUMBER	NAVY SPEC. OR DRAWING NUMBER	MFR. DESIG.	SPECIAL TOL. RATING OR MODIFICATION	CONTRACTOR'S DRAWING AND PART NUMBER	BOX NUMBER	QUANTITY	SPARE PARTS
											ALL SYMBOL DESIGNATIONS INVOLVED
			PLUGS (CLASS 49)								
	P-601	NOT USED									
	P-602	NOT USED									
X	P-603	DYNAMOTOR PLUG	3 CIRCUIT, MALE	-49176		16	P-303-AB	M-7408053 P1	1	4	P-603
X	P-703	PLUG - GENERATOR TO DYNAMOTOR	4 CONTACT, FEMALE	-49069		17		P-7708342 P3			P-703, P-1608, P-1808
X	P-703A	FILLER FOR P-703	PANEL & CONTACT ASSEMBLY FOR P-703			17		P-7708342 P8			P-703A, P-1608A, P-1809A
X	P-901	INPUT PLUG	BROWN, FEMALE			22	H150	T-7607915 P52			P-901, P-1002
X	P-1001	M.F. LINE PLUG	MALE, RUBBER HANDLE GRIP			17	#HR-B OR CAT. #JK	T-7607921 P40			P-1001 P-1003
X	P-1002	A.C. LINE PLUG	SAME AS P-901								
X	P-1003	H.F. LINE PLUG	SAME AS P-1001								
X	P-1405	PLUG POWER TO M.F. RECEIVER	8 CONTACT, FEMALE	-49171		17		P-7708342 P4			P-1405, P-1407, P-1505, P-1506, P-1903
X	P-1405A	FILLER FOR P-1405	PANEL & CONTACT ASSEMBLY FOR P-1405			17		P-7708342 P9			P-1405A, P-1407A, P-1505A, P-1506A
X	P-1407	PLUG POWER TO M.F. RECEIVER	SAME AS P-1405	-49171							
X	P-1407A	FILLER FOR P-1407	SAME AS P-1405A								
X	P-1505	PLUG, POWER TO H.F.	SAME AS P-1405	-49171							
X	P-1505A	FILLER FOR P-1505	SAME AS P-1405A								
X	P-1506	PLUG, POWER TO H.F. RECEIVER	SAME AS P-1405	-49171							
X	P-1506A	FILLER FOR P-1506	SAME AS P-1405A								
X	P-1601	PLUG, BATTERY TO DYNAMOTOR POWER	3 CONTACT, FEMALE	-49168		5	WK-C5-23 C-1/2	VAR. #1 P-7708334 P5			P-1601, P-1701, P-1702
X	P-1601A	FILLER FOR P-1601	CONTACT ASSEMBLY, LESS 90° FITTING FOR P-1601			5		P-7708334 P6			P-1601A, P-1701A, P-1702A
X	P-1606	PLUG, BATTERY TO DYNAMOTOR POWER	SAME AS P-703	-49069							
X	P-1608A	FILLER FOR P-1608	SAME AS P-703A								
X	P-1701	PLUG, BATTERY TO BATTERY	SAME AS P-1601	-49168							
X	P-1701A	FILLER FOR P-1701	SAME AS P-1601A								

SUPPLIED IN SPARE SUB ASSEMBLIES, D-601 OR D-602.

P-7713092

TABLE II (CONTINUED)

PARTS AND SPARE PARTS LIST BY SYMBOL DESIGNATION FOR RBM-5 SEMI-PORTABLE RADIO RECEIVER EQUIPMENT

BATTERY OR 60 CY. A.C. SUPPLY	SYMBOL DESIG.	FUNCTION	DESCRIPTION	NAVY TYPE NUMBER	NAVY SPEC. OR DRAWING NUMBER	MFK. DESIG.	SPECIAL TOL. RATING OR MODIFICATION	CONTRACTOR'S DRAWING AND PART NUMBER	BOX NUMBER	QUANTITY	ALL SYMBOL DESIGNATIONS INVOLVED
X	P-1702	PLUG, BATTERY TO BATTERY	SAME AS P-1601	-49168							
X	P-1702A	FILLER FOR P-1702	SAME AS P-1601A								
X	P-1809	PLUG, GENERATOR TO DYNAMOTOR	SAME AS P-703	-49069							
X	P-1809A	FILLER FOR P-1809	SAME AS P-703A								
X	P-1903	PLUG, POWER INPUT CABLE	SAME AS P-1405	-49171							
X	P-1903A	FILLER FOR P-1903	SAME AS P-1405A								P-1903A, P-2005A
X	P-1907	PLUG, POWER INPUT CABLE	4 CONTACT	-49170		17		P-7708342 P10			P-1907, P-2009
X	P-1907A	FILLER FOR P-1907	CONTACT ASSEMBLY FOR P-1907			17		P-7708342 P8			P-1907A, P-2009A
X	P-2003	PLUG, POWER INPUT CABLE	SAME AS P-1405	-49171							P-2003
X	P-2003A	FILLER FOR P-2003	SAME AS P-1405A								
X	P-2009	PLUG, POWER INPUT CABLE	SAME AS P-1907	-49170							
X	P-2009A	FILLER FOR P-2009	SAME AS P-1907A								
			RESISTORS, RHEOSTATS AND POTENTIOMETER (CLASS 65)								
X	R-401	ANTENNA BLEEDER RESISTOR	0.47 MEG. $\pm 10\%$, 1/2 WATT, COMPOSITION	-63360		9 10	BT-1/2 TYPE EB	T-7608015 P370			R-401, R-419, R-435, R-441, R-447, R-501, R-535, R-541, R-547, R-573
X	R-402	R.F. A.V.C. FILTER RESISTOR	0.1 MEG. $\pm 10\%$, 1/2 WATT, COMPOSITION	-63360		9 10	BT-1/2 TYPE EB	T-7608015 P371			R-402, R-418, R-422, R-438, R-460, R-502, R-518, R-522, R-538
X	R-403	1ST A.F. SCREEN FILTER RESISTOR	0.43 MEG. $\pm 5\%$, 1/2 WATT, COMPOSITION	-63355		9 10	BT-1/2 TYPE EB	T-7608015 P372			R-403, R-503
X	R-404	R.F. SCREEN FILTER RESISTOR	33,000 OHMS $\pm 10\%$, 1/2 WATT, COMPOSITION	-63360		9 10	BT-1/2 TYPE EB	T-7608015 P373			R-404, R-412 R-420, R-515
X	R-405	R.F. PLATE FILTER RESISTOR	2200 OHMS $\pm 10\%$, 1/2 WATT, COMPOSITION	-63360		9 10	BT-1/2 TYPE EB	T-7608015 P374			R-405, R-417, R-421, R-425, R-505, R-516, R-517, R-527, R-525
X	R-406	BAND 4 LINK, EQUALIZER RESISTOR	10 OHMS $\pm 10\%$, 1/2 WATT	-63678-10		9	BW-1/2	T-7608015 P375			R-406

TABLE II (CONTINUED)											SPARE PARTS	
PARTS AND SPARE PARTS LIST BY SYMBOL DESIGNATION FOR RBM-5 SEMI-PORTABLE RADIO RECEIVER EQUIPMENT												
BATTERY OR 60 CY. A.C. SUPPLY	SYMBOL DESIG.	FUNCTION	DESCRIPTION	NAVY TYPE NUMBER	NAVY SPEC. OR DRAWING NUMBER	MFR.	MFR. DESIG.	SPECIAL TOL. RATING OR MODIFICATION	CONTRACTOR'S DRAWING AND PART NUMBER	BOX NUMBER	QUANTITY	ALL SYMBOL DESIGNATIONS INVOLVED
	RESISTORS, RHEOSTATS AND POTENTIOMETERS (CLASS 63) CONTINUED											
X	R-407	BAND 3 LINK, EQUALIZER RESISTOR	82 OHMS ±10%, 1/2 WATT	-63678-10		9	BW-1/2		T-7608015 P376			R-407, R-455, R-456
X	R-408	BAND 2 LINK, EQUALIZER RESISTOR	47 OHMS ±10%, 1/2 WATT	-63678-10		9	BW-1/2		T-7608015 P377			R-408
X	R-409	BAND 1 LINK, EQUALIZER RESISTOR	150 OHMS ±10%, 1/2 WATT	-63678-10		9	BW-1/2		T-7608015 P378			R-409
X	R-410	R.F. GRID LEAK RESISTOR	2.2 MEG. ±10%, 1/2 WATT, CERAMIC	-63360-10		9	F-1/2		T-7605849 P73			R-410, R-510, R-548
X	R-411	1ST DET. CATHODE BIAS RESISTOR	1500 OHMS ±10%, 1/2 WATT, COMPOSITION	-63360		9	BT-1/2		T-7608015 P380			R-411, R-511
X	R-412	1ST DET. SCREEN FILTER RESISTOR	SAME AS R-404	-63360								
X	R-413	2ND A.F. PLATE LOAD RESISTOR	0.22 MEG. ±10%, 1/2 WATT, COMPOSITION	-63360		9	BT-1/2		T-7608015 P382			R-413, R-426, R-427, R-513, R-526 R-527
X	R-414	OSC. GRID LEAK RESISTOR	10,000 OHMS ±5%, 1/2 WATT, COMPOSITION	-63355		9	BT-1/2		T-7608018 P383			R-414
X	R-415	OSC. SCREEN FILTER RESISTOR	27,000 OHMS ±10%, 1/2 WATT, COMPOSITION	-63360		9	BT-1/2		T-7608015 P384			R-415
X	R-416	OSC. PLATE FILTER RESISTOR	4700 OHMS, 1/2 WATT, COMPOSITION	-63360		9	BT-1/2		T-7608015 P385			R-416, R-424, R-504, R-520, R-524
X	R-417	1ST DET. PLATE FILTER RESISTOR	SAME AS R-405	-63360								
X	R-418	1ST I.F. A.V.C. FILTER RESISTOR	SAME AS R-402	-63360								
X	R-419	A.V.C. FILTER RESISTOR	SAME AS R-401	-63360								
X	R-420	1ST I.F. SCREEN FILTER RESISTOR	SAME AS R-404	-63360								
X	R-421	1ST I.F. PLATE FILTER RESISTOR	SAME AS R-405	-63360								
X	R-422	1ST DET. A.V.C. FILTER RESISTOR	SAME AS R-402	-63360								
X	R-423	4TH A.V.C. DIODE LOAD RESISTOR	0.33 MEG. ±10%, 1/2 WATT, COMPOSITION	-63360		9	BT-1/2		T-7608015 P392			R-423, R-451, R-469, R-569
X	R-424	2ND I.F. SCREEN FILTER RESISTOR	SAME AS R-416	-63360								
X	R-425	2ND I.F. PLATE FILTER RESISTOR	SAME AS R-405	-63360								
X	R-426	SIGNAL DIODE FILTER RESISTOR	SAME AS R-413	-63360								

TABLE II (CONTINUED)

PARTS AND SPARE PARTS LIST BY SYMBOL DESIGNATION FOR RBM-5 SEMI-PORTABLE RADIO RECEIVER EQUIPMENT

BATTERY OR 60 CY. A.C. SUPPLY	SYMBOL DESIG.	FUNCTION	DESCRIPTION	NAVY TYPE NUMBER	NAVY SPEC. OR DRAWING NUMBER	MFR. DESIG.	SPECIAL TOL. RATING OR MODIFICATION	CONTRACTOR'S DRAWING AND PART NUMBER	SPARE PARTS	
									BOX NUMBER	QUANTITY
RESISTORS, RHEOSTATS AND POTENTIOMETERS (CLASS 63) CONTINUED										
X	R-427	SIGNAL DIODE LOAD RESISTOR	SAME AS R-413	-63560						
X	R-428	PEAK LIMITER RETURN RESISTOR	1 MEG. $\pm 10\%$, 1/2 WATT, COMPOSITION	-63360		9 10	BT-1/2 TYPE EB	T-7608015 P397		R-428, R-436, R-462, R-528, R-536, R-562
X	R-429	2ND A.F. CATHODE BIAS RESISTOR	15,000 OHMS $\pm 10\%$, 1/2 WATT, COMPOSITION	-63360		9 10	BT-1/2 TYPE EB	T-7608015 P398		R-429, R-440, R-442, R-529
X	R-430	1ST A.F. CATHODE BIAS RESISTOR	1000 OHMS $\pm 5\%$, 1/2 WATT, COMPOSITION	-63355		9 10	BT-1/2 TYPE EB	T-7608015 P399		R-430, R-452, R-530
X	R-431	1ST A.V.C. DIODE LOAD RESISTOR	SAME AS R-423	-63360						
X	R-432	A.V.C. DIODE DELAY RESISTOR	22,000 OHMS $\pm 5\%$, 1/2 WATT, COMPOSITION	-63355		9 10	BT-1/2 TYPE EB	T-7608015 P401		R-432, R-467, R-567
X	R-433A	OUTPUT LIMITER CONTROL POTENTIOMETER	75,000 OHMS, 2 WATTS	-631221		10	TYPE JJ	P-7708226 P3		R-433A, R-433B, R-533A, R-533B
X	R-433B	A.F. GAIN CONTROL POTENTIOMETER	1 MEG., 2 WATT, (A PART OF R-433A)							
X	R-434	3RD A.F. CATHODE BIAS RESISTOR	620 OHMS $\pm 5\%$, 1/2 WATT, COMPOSITION	-63355		9 10	BT-1/2 TYPE EB	T-7608015 P404		R-434, R-534
X	R-435	3RD A.F. GRID LEAK RESISTOR	SAME AS R-401	-63360						
X	R-436	2ND A.F. GRID CURRENT LIMITER RESISTOR	SAME AS R-428	-63360						
X	R-437	R.F. GAIN CONTROL POTENTIOMETER	2500 OHMS, 2 WATTS	-631220		10	TYPE J	P-7708226 P4		R-437
X	R-438	1ST A.F. PLATE LOAD RESISTOR	SAME AS R-402	-63360						
X	R-439	CW OSC. FILTER RESISTOR	10,000 OHMS $\pm 10\%$, 1/2 WATT, COMPOSITION	-63360		9 10	BT-1/2 TYPE EB	T-7608015 P409		R-439, R-450, R-459, R-539, R-550
X	R-440	CW OSC. PLATE LOAD RESISTOR	SAME AS R-429	-63360						
X	R-441	CW OSC. SCREEN FILTER RESISTOR	SAME AS R-401	-63360						
X	R-442	CW OSC. GRID LEAK RESISTOR	SAME AS R-429	-63360						
X	R-443	1ST BLEEDER RESISTOR	10,000 OHMS $\pm 10\%$, 2 WATTS, COMPOSITION	-63474		9	BT-2	T-7608015 P413		R-443, R-472, R-543, R-572
X	R-444	2ND BLEEDER RESISTOR	30,000 OHMS $\pm 10\%$, 2 WATTS, COMPOSITION	-63474		9	BT-2	T-7608015 P414		R-444, R-476, R-544, R-576

10-25

TABLE 11 (CONTINUED)

PARTS AND SPARE PARTS LIST BY SYMBOL DESIGNATION FOR RBM-5 SEMI-PORTABLE RADIO RECEIVER EQUIPMENT										SPARE PARTS		
BATTERY OR GO CIR. ASS SUPPLY	SYMBOL DESIG.	FUNCTION	DESCRIPTION	NAVY TYPE NUMBER	NAVY SPEC. OR DRAWING NUMBER	MFR.	MFR. DESIG.	SPECIAL TOL. RATING OR MODIFICATION	CONTRACTOR'S DRAWING AND PART NUMBER	BOX NUMBER	QUANTITY	ALL SYMBOL DESIGNATIONS INVOLVED
	RESISTORS, RHEOSTATS AND POTENTIOMETERS (CLASS 63) CONTINUED											
X	R-445	DELAY SUPPLY A.V.C. RESISTOR	0.68 MEG. $\pm 5\%$, 1/2 WATT, COMPOSITION	-63355		9	BT-1/2		T-7608015 P415			R-445, R-449, R-474, R-549
X	R-446	DIAL LIGHT DIMMING RHEOSTAT	50 OHMS $\pm 10\%$, 2 WATTS, COMPOSITION	-631277		10	TYPE J		P-7708226 P2			R-446, R-546
X	R-447	2ND A.F. GRID LEAK RESISTOR	SAME AS R-401	-63360								
X	R-448	1ST DET. LEAK RESISTOR	2.2 MEG. $\pm 10\%$, 1/2 WATT, COMPOSITION	-63360		9	BT-1/2		T-7608015 P618			R-448, R-570
X	R-449	PEAK LIMITER LOAD RESISTOR	0.68 MEG. $\pm 10\%$, 1/2 WATT, COMPOSITION	-63360		10	TYPE EB					
X	R-450	1ST A.F. PLATE FILTER RESISTOR	SAME AS R-439	-63360		9	BT-1/2		T-7608015 P419			
X	R-451	R.F. CATHODE RESISTOR	120 OHMS $\pm 5\%$, 1/2 WATT	-63678-5		9	EW-1/2		T-7608015 P421			R-451
X	R-452	LOAD OSC. PLATE RESISTOR	SAME AS R-430	-63355								
X	R-453	R.F. PLATE TRANS. BAND 1 SHUNT RESISTOR	SAME AS R-401	-63360								R-453, R-454
X	R-454	DET. GRID TRANS. BAND 1 SHUNT RESISTOR	SAME AS R-401	-63360								
X	R-455	1ST I.F. SECONDARY SERIES RESISTOR	SAME AS R-407	-63678-10								
X	R-456	2ND I.F. SECONDARY SERIES RESISTOR	SAME AS R-407	-63678-10								
X	R-457	1ST I.F. GRID LEAK RESISTOR	SAME AS R-428									R-457, R-470
X	R-458	1ST I.F. CATHODE BIAS RESISTOR	390 OHMS $\pm 10\%$, 1/2 WATT, COMPOSITION	-63360		9	BT-1/2		T-7608015 P428			R-458, R-488
X	R-459	GW OSC. FILTER RESISTOR	SAME AS R-439	-63360								
X	R-460	R.F. SCREEN BLEEDER RESISTOR	SAME AS R-402	-63360								
X	R-461	SERIES OSC. RESISTOR	510 OHMS $\pm 5\%$, 1/2 WATT, COMPOSITION	-63355		9	BT-1/2		T-7608015 P431			R-481
X	R-462	CV AUDIO DIVIDER RESISTOR	SAME AS R-428	-63360		10	TYPE EB					
X	R-463	3RD A.F. PLATE & SCREEN FILTER RESISTOR	20,000 OHMS $\pm 10\%$, 1 WATT	-63288		10	TYPE GB		T-7608018 P433			R-463, R-464, R-563, R-564
X	R-464	3RD A.F. PLATE & SCREEN FILTER RESISTOR	SAME AS R-463	-63288								
X	R-465	2ND A.F. SCREEN FILTER RESISTOR	47,000 OHMS $\pm 10\%$, 1/2 WATT, COMPOSITION	-63360		9	BT-1/2		T-7608016 P435			R-465, R-466, R-540, R-565, R-566

92-101

TABLE 11 (CONTINUED)

PARTS AND SPARE PARTS LIST BY SYMBOL DESIGNATION FOR RBM-5 SEMI-PORTABLE RADIO RECEIVER EQUIPMENT										SPARE PARTS		
BATTERY OR 60 CY. A.C. SUPPLY	SYMBOL DESIG.	FUNCTION	DESCRIPTION	NAVY TYPE NUMBER	NAVY SPEC. OR DRAWING NUMBER	MFR.	MFR. DESIG.	SPECIAL TOL. RATING OR MODIFICATION	CONTRACTOR'S DRAWING AND PART NUMBER	BOX NUMBER	QUANTITY	ALL SYMBOL DESIGNATIONS INVOLVED
	RESISTORS, RHEOSTATS AND POTENTIOMETERS (CLASS 65) CONTINUED											
X	R-466	2ND A.F. PLATE FILTER RESISTOR	SAME AS R-465	-63360								
X	R-467	FEEDBACK RESISTOR	SAME AS R-432	-63355								
X	R-468	2ND I.F. CATHODE BIAS RESISTOR	SAME AS R-458	-63360								
X	R-469	O.L. CONTROL SERIES RESISTOR	SAME AS R-423	-63360								
X	R-470	2ND I.F. LEAK RESISTOR	SAME AS R-428	-63360								
X	R-471	1ST A.F. LEAK RESISTOR	SAME AS R-448	-63360								R-471, R-477, R-571
X	R-472	1ST BLEEDER RESISTOR	SAME AS R-443	-63474								
X	R-473	2ND A.V.C. DIODE LOAD RESISTOR	1.5 MEG. $\pm 10\%$, 1/2 WATT, COMPOSITION	-63360		9 10	BT-1/2 TYPE EB		T-7608016 P443			R-473
X	R-474	3RD A.V.C. DIODE LOAD RESISTOR	SAME AS R-449	-63360								
X	R-475	DELAY SUPPLY RESISTOR	0.15 MEG. $\pm 5\%$, 1/2 WATT, COMPOSITION	-63355		9 10	BT-1/2 TYPE EB		T-7608016 P445			R-475, R-545, R-575
X	R-476	2ND BLEEDER RESISTOR	SAME AS R-444	-63474								
X	R-477	A.V.C. LOAD SHUNT RESISTOR	SAME AS R-448	-63360								
X	R-501	ANTENNA BLEEDER RESISTOR	SAME AS R-401	-63360								
X	R-502	R.F. A.V.C. FILTER RESISTOR	SAME AS R-402	-63360								
X	R-503	1ST A.F. SCREEN FILTER RESISTOR	SAME AS R-403	-63355								
X	R-504	R.F. SCREEN FILTER RESISTOR	SAME AS R-416	-63360								
X	R-505	R.F. PLATE FILTER RESISTOR	SAME AS R-405	-63360								
X	R-506	R.F. CATHODE FILTER RESISTOR	10 OHMS, 1/2 WATT	-63360		10	TYPE EB		T-7608016 P468			R-506
	R-507 TO R-509	NOT USED										
X	R-510	R.F. GRID LEAK RESISTOR	SAME AS R-410	-63360-10								
X	R-511	1ST DET. CATHODE BIAS RESISTOR	SAME AS R-411	-63360								

TABLE 11 (CONTINUED)

PARTS AND SPARE PARTS LIST BY SYMBOL DESIGNATION FOR RBM-S SEMI-PORTABLE RADIO RECEIVER EQUIPMENT

SPARE PARTS

BATTERY OR 60 CY. A.C. SUPPLY	SYMBOL DESIG.	FUNCTION	DESCRIPTION	NAVY TYPE NUMBER	NAVY SPEC. OR DRAWING NUMBER	MFR.	MFR. DESIG.	SPECIAL TOL. RATING OR MODIFICATION	CONTRACTOR'S DRAWING AND PART NUMBER	BOX NUMBER	QUANTITY	ALL SYMBOL DESIGNATIONS INVOLVED
X	R-512	1ST DET. SCREEN FILTER RESISTOR	88,000 OHMS $\pm 10\%$, 1/2 WATT, COMPOSITION	-63360		9 10	BT-1/2 TYPE EB		T-7608016 P474			R-512
X	R-513	2ND A.F. PLATE LOAD RESISTOR	SAME AS R-413	-63360								
X	R-514	OSC. GRID LEAK RESISTOR	20,000 OHMS $\pm 5\%$, 1/2 WATT, COMPOSITION	-63355		9 10	BT-1/2 TYPE EB		T-7608016 P476			R-514
X	R-515	OSC. SCREEN FILTER RESISTOR	SAME AS R-404	-63360								
X	R-516	OSC. PLATE FILTER RESISTOR	SAME AS R-405	-63360								
X	R-517	1ST DET. PLATE FILTER RESISTOR	SAME AS R-405	-63360								
X	R-518	1ST I.F. A.V.C. FILTER RESISTOR	SAME AS R-402	-63360								
X	R-519	A.V.C. FILTER RESISTOR	0.47 MEG., 1/2 WATT, CERAMIC	-63360-10		9	F-1/2		T-7608016 P481			R-519, R-523
X	R-520	1ST I.F. SCREEN FILTER RESISTOR	SAME AS R-416	-63360								
X	R-521	1ST I.F. PLATE FILTER RESISTOR	SAME AS R-405	-63360								
X	R-522	1ST DET. A.V.C. FILTER RESISTOR	SAME AS R-402	-63360								
X	R-523	3RD A.V.C. DIODE LOAD RESISTOR	SAME AS R-519	-63360-10								
X	R-524	2ND I.F. SCREEN FILTER RESISTOR	SAME AS R-416	-63360								
X	R-525	2ND I.F. PLATE FILTER RESISTOR	SAME AS R-405	-63360								
X	R-526	SIGNAL DIODE FILTER RESISTOR	SAME AS R-413	-63360								
X	R-527	SIGNAL DIODE LOAD RESISTOR	SAME AS R-413	-63360								
X	R-528	PEAK LIMITER RETURN RESISTOR	SAME AS R-428	-63360								
X	R-529	2ND A.F. CATHODE BIAS RESISTOR	SAME AS R-429	-63360								
X	R-530	1ST A.F. CATHODE BIAS RESISTOR	SAME AS R-430	-63355								

TABLE II (CONTINUED)

PARTS AND SPARE PARTS LIST BY SYMBOL DESIGNATION FOR RBM-S SEMI-PORTABLE RADIO RECEIVER EQUIPMENT										SPARE PARTS	
BATTERY OR 50 CY. A.C. SUPPLY	SYMBOL DESIG.	FUNCTION	DESCRIPTION	NAVY TYPE NUMBER	NAVY SPEC. OR DRAWING NUMBER	MFR. DESIG.	SPECIAL TOL. RATING OR MODIFICATION	CONTRACTOR'S DRAWING AND PART NUMBER	BOX NUMBER	QUANTITY	ALL SYMBOL DESIGNATIONS INVOLVED
	RESISTORS, RHEOSTATS AND POTENTIOMETERS (CLASS 63) CONTINUED										
X	R-531	1ST A.V.C. DIODE LOAD RESISTOR	0.39 MEG. $\pm 10\%$, 1/2 WATT, COMPOSITION	-63360		9 BT-1/2 10 TYPE EB		T-7608016 P495			R-531
X	R-532	A.V.C. DIODE DELAY RESISTOR	3000 OHMS $\pm 5\%$, 1/2 WATT, COMPOSITION	-63355		9 BT-1/2		T-7608016 P494			R-532
X	R-533A	OUTPUT LIMITER CONTROL POTENTIOMETER	SAME AS R-433A	-631221							
X	R-533B	A.F. GAIN CONTROL POTENTIOMETER	PART OF R-533A								
X	R-534	3RD A.F. CATHODE BIAS RESISTOR	SAME AS R-434	-63355							
X	R-535	3RD A.F. GRID LEAK RESISTOR	SAME AS R-401	-63360							
X	R-536	2ND A.F. CURRENT LIMITER RESISTOR	SAME AS R-428	-63360							
X	R-537	R.F. GAIN CONTROL POTENTIOMETER	2000 OHMS, 2 WATTS	-631219		10 TYPE J		P-7708226 P5			R-537
X	R-538	1ST A.F. PLATE LOAD RESISTOR	SAME AS R-402	-63360							
X	R-539	CW OSC. FILTER RESISTOR	SAME AS R-439	-63360							
X	R-540	CW OSC. PLATE LOAD RESISTOR	SAME AS R-465	-63360							
X	R-541	CW OSC. SCREEN FILTER RESISTOR	SAME AS R-401	-63360							
X	R-542	CW OSC. GRID LEAK RESISTOR	SAME AS R-465	-63360							R-542
X	R-543	1ST BLEEDER RESISTOR	SAME AS R-443	-63474							
X	R-544	2ND BLEEDER RESISTOR	SAME AS R-444	-63474							
X	R-545	DELAY SUPPLY A.V.C. RESISTOR	SAME AS R-475	-63355							
X	R-546	DIAL LIGHT DIMMING RHEOSTAT	SAME AS R-446	-631217							
X	R-547	2ND A.F. GRID LEAK RESISTOR	SAME AS R-401	-63360							
X	R-548	1ST DET. GRID LEAK RESISTOR	SAME AS R-410	-63360-10							
X	R-549	PEAK LIMITER LOAD RESISTOR	SAME AS R-449	-63360							
X	R-550	1ST A.F. PLATE FILTER RESISTOR	SAME AS R-439	-63360							

TABLE II (CONTINUED)

PARTS AND SPARE PARTS LIST BY SYMBOL DESIGNATION FOR RBM-5 SEMI-PORTABLE RADIO RECEIVER EQUIPMENT

SPARE PARTS

BATTERY OR 60 CY. A.C. SUPPLY	SYMBOL DESIG.	FUNCTION	DESCRIPTION	NAVY TYPE NUMBER	NAVY SPEC. OR DRAWING NUMBER	MFR.	MFR. DESIG.	SPECIAL TOL. RATING OR MODIFICATION	CONTRACTOR'S DRAWING AND PART NUMBER	BOX NUMBER	QUANTITY	ALL SYMBOL DESIGNATIONS INVOLVED
X	R-551	R.F. CATHODE RESISTOR	SAME AS R-409	-63678-10								R-551, R-558, R-568
X	R-552	LOAD OSC. PLATE RESISTOR	SAME AS R-461	-63360								R-552
	R-553 TO R-557	NOT USED										
X	R-558	1ST I.F. CATHODE BIAS RESISTOR	SAME AS R-409	-63678-10								
	R-559 TO R-561	NOT USED										
X	R-562	CW AUDIO DIVIDER RESISTOR	SAME AS R-428	-63360								
X	R-563	3RD A.F. PLATE & SCREEN FILTER RESISTOR	SAME AS R-463	-63288								
X	R-564	3RD A.F. PLATE & SCREEN FILTER RESISTOR	SAME AS R-463	-63288								
X	R-565	2ND A.F. SCREEN FILTER RESISTOR	SAME AS R-465	-63360								
X	R-566	2ND A.F. PLATE FILTER RESISTOR	SAME AS R-465	-63360								
X	R-567	FEEDBACK RESISTOR	SAME AS R-432	-63355								
X	R-568	2ND I.F. CATHODE BIAS RESISTOR	SAME AS R-409	-63678-10								
X	R-569	O.L. CONTROL SERIES RESISTOR	SAME AS R-423	-63360								
X	R-570	2ND I.F. LEAK RESISTOR	SAME AS R-448	-63360								
X	R-571	1ST A.F. GRID LEAK RESISTOR	SAME AS R-448	-63360								
X	R-572	1ST BLEEDER RESISTOR	SAME AS R-443	-63474								
X	R-573	2ND A.V.C. DIODE LOAD RESISTOR	SAME AS R-401	-63360								
	R-574	NOT USED										
X	R-575	DELAY SUPPLY RESISTOR	SAME AS R-475	-63355								
X	R-576	2ND BLEEDER RESISTOR	SAME AS R-444	-63474								
X	R-601	PANEL LIGHT DIMMER RHEOSTAT	100 OHMS, 2 WATTS, COMPOSITION	-631218		10	TYPE J		T-7607845 P58			R-601
X	R-901	BLEEDER RESISTOR	10,000 OHMS ±10%	-631182-10		9	MW-4		T-7607915 P47			R-901

TABLE II (CONTINUED)

PARTS AND SPARE PARTS LIST BY SYMBOL DESIGNATION FOR RBM-5 SEMI-PORTABLE RADIO RECEIVER EQUIPMENT

SPARE PARTS

BATTERY OR SO. C.T. A.C. SUPPLY	SYMBOL DESIG.	FUNCTION	DESCRIPTION	NAVY TYPE NUMBER	NAVY SPEC. OR DRAWING NUMBER	MFR.	MFR. DESIG.	SPECIAL TOL. RATING OR MODIFICATION	CONTRACTOR'S DRAWING AND PART NUMBER	BOX NUMBER	QUANTITY	ALL SYMBOL DESIGNATIONS INVOLVED
X	S-401A	ANTENNA PRI. BAND SWITCH	S.P., 4 POSITIONS, THREE BREAKS PER CIRCUIT, ROTARY TYPE			11	RM CERAMIC		T-7607863 P4			S-401A, S-401C, S-401D, S-501A, S-501C, S-501F
X	S-401B	ANTENNA SEC. BAND SWITCH	SAME AS S-401A									S-401B, S-401E, S-401G, S-501B, S-501D
X	S-401C	R.F. PLATE TAPS BAND SWITCH	SAME AS S-401A									
X	S-401D	R.F. PLATE COILS BAND SWITCH	SAME AS S-401A									
X	S-401E	DET. GRID BAND SWITCH	SAME AS S-401A									
X	S-401F	OSC. COILS BAND SWITCH	D.P., 4 POSITIONS, THREE BREAKS PER CIRCUIT, ROTARY TYPE			11	RM CERAMIC		T-7607863 P2			S-401F, S-501E
X	S-401G	OSC. TAPS BAND SWITCH	SAME AS S-401A									
X	S-401H	OSC. CATHODE & PADS BAND SWITCH	D.P., 4 POSITIONS, THREE BREAKS PER CIRCUIT, ROTARY TYPE			11	RM CERAMIC		T-7607863 P3			S-401H, S-501G
X	S-402A	1ST I.F. SELECTIVITY SWITCH	D.P., 2 POSITIONS, TWO BREAKS PER CIRCUIT, ROTARY TYPE			11	RM CERAMIC		T-7607866 P1			S-402A, S-402B, S-502A, S-502B
X	S-402B	2ND I.F. SELECTIVITY SWITCH	SAME AS S-402A									
X	S-403A	RECEPTION O.L., - CW OSC. SWITCH	4 P., 4 POSITIONS, ROTARY TYPE			11	PHENOLIC		T-7607866 P3			S-403A, S-403B, S-503A, S-503B
X	S-403B	RECEPTION A.V.C., A.F. GAIN CONTROL SWITCH	PART OF S-403A									
X	S-404	NOISE PEAK LIMITER SWITCH	S.P.D.T., ONE BREAK PER CIRCUIT, TOGGLE TYPE	-24002	RE24AA118	12	I-GA3C22		T-7608017 P569			S-404, S-504
X	S-501A	ANTENNA PRI. BAND SWITCH	SAME AS S-401A									
X	S-501B	ANTENNA SEC. BAND SWITCH	SAME AS S-401A									
X	S-501C	R.F. PLATE COILS BAND SWITCH	SAME AS S-401A									
X	S-501D	DET. GRID BAND SWITCH	SAME AS S-401A									
X	S-501E	OSC. COILS BAND SWITCH	SAME AS S-401F									
X	S-501F	OSC. TAPS BAND SWITCH	SAME AS S-401A									
X	S-501G	OSC. CATHODE AND PADS BAND SWITCH	SAME AS S-401H									

TABLE II (CONTINUED)										SPARE PARTS		
PARTS AND SPARE PARTS LIST BY SYMBOL DESIGNATION FOR RBM-5 SEMI-PORTABLE RADIO RECEIVER EQUIPMENT												
BATTERY OR GO CY. A.C. SUPPLY	SYMBOL DESIG.	FUNCTION	DESCRIPTION	NAVY TYPE NUMBER	NAVY SPEC. OR DRAWING NUMBER	MFR. DESIG.	SPECIAL TOL. RATING OR MODIFICATION	CONTRACTOR'S DRAWING AND PART NUMBER	BOX NUMBER	QUANTITY	ALL SYMBOL DESIGNATIONS INVOLVED	
	SWITCHES (CLASS 24) CONTINUED											
X	S-501H	SWITCH SHAFT GROUNDING	CONTINUOUS CIRCUIT			24		K-7812537 G1			S-501H FOR CCT ONLY	
X	S-502A	1ST I.F. SELECTIVITY SWITCH	SAME AS S-402A									
X	S-502B	2ND I.F. SELECTIVITY SWITCH	SAME AS S-402A									
X	S-503A	RECEPTION O.L. - C.W. OSC. SWITCH	SAME AS S-403A									
X	S-503B	RECEPTION A.V.C., A.F. GAIN CONTROL SWITCH	PART OF S-503A									
X	S-504	NOISE PEAK LIMITER SWITCH	SAME AS S-404	-24002								
X	S-601A	H.F. RECEIVER LOW VOLTAGE SWITCH	TWO POLES, THREE POSITIONS, 3 AMPS., 250 VOLTS, TOGGLE, ROTARY TYPE	-24121	RE24AA118A	19 #1571-AT		P-7708223 G2			S-601A, S-601B, S-602A, S-602B	
X	S-601B	H.F. RECEIVER DYN. SWITCH	PART OF S-601A									
X	S-602A	M.F. RECEIVER LOW VOLTAGE SWITCH	SAME AS S-601A	-24121								
X	S-602B	M.F. RECEIVER DYN. SWITCH	PART OF S-602A									
X	S-603A	M.F. RECEIVER PHONE TRANSFER SWITCH	D.P., FOUR POSITIONS, WAFER TYPE			11 RM BAKELITE		T-7607866 P6			S-603A	
X	S-603B	H.F. RECEIVER PHONE TRANSFER SWITCH	PART OF S-603A									
X	S-604	H.F. SIDETONE SWITCH	S.P.S.T., 3 AMPS., 250 VOLTS, TOGGLE TYPE	-24115	RE24AA119A	19 17P5 HOUSING		P-7708223 P1			S-604, S-605	
X	S-605	I.F. SIDETONE SWITCH	SAME AS S-604	-24115								
X	S-606	MAIN POWER SWITCH	S.P.S.T., 25 AMPS., 15 VOLTS D.C., TOGGLE TYPE	-24118		20		P-7708397 P1			S-606	
X	S-901	MAIN POWER SWITCH	SAME AS S-604	-24115							S-901, S-902	
X	S-902	SINGLE DUAL SWITCH	SAME AS S-604	-24115								
X	S-1001A	H.F. RECEIVER FILAMENTS SWITCH	D.P., THREE POSITIONS, TOGGLE, ROTARY TYPE	-24117	RE24AA118A	19 #1571-AT		P-7708223 G1			S-1001A, S-1001B, S-1002A, S-1002B	
X	S-1001B	H.F. RECEIVER H.V. SUPPLY SWITCH	PART OF S-1001A									
X	S-1002A	M.F. RECEIVER FILAMENTS SWITCH	SAME AS S-1001A	-24117								
X	S-1002B	M.F. RECEIVER H.V. SUPPLY SWITCH	PART OF S-1002A									

TABLE II (CONTINUED)										SPARE PARTS		
PARTS AND SPARE PARTS LIST BY SYMBOL DESIGNATION FOR RBM-5 SEMI-PORTABLE RADIO RECEIVER EQUIPMENT												
BATTERY OR GO CY. A.C. SUPPLY	SYMBOL DESIG.	FUNCTION	DESCRIPTION	NAVY TYPE NUMBER	NAVY SPEC. OR DRAWING NUMBER	MFR.	MFR. DESIG.	SPECIAL TOL. RATING OR MODIFICATION	CONTRACTOR'S DRAWING AND PART NUMBER	BOX NUMBER	QUANTITY	ALL SYMBOL DESIGNATIONS INVOLVED
	SWITCHES (CLASS 24) CONTINUED											
X	S-1003A	H.F. RECEIVER PHONE TRANSFER SWITCH	D.P., FOUR POSITIONS, WAFER TYPE			11	RM BAKELITE		T-7607866 P4			S-1003A, S-1003B
X	S-1003B	M.F. RECEIVER PHONE TRANSFER SWITCH	PART OF S-1003A									
X	S-1004	H.F. SIDETONE SWITCH	SAME AS S-604	-24115								S-1004, S-1005, S-1006
X	S-1005	I.F. SIDETONE SWITCH	SAME AS S-604	-24115								
X	S-1006	MAIN POWER SWITCH	SAME AS S-604	-24115								
<u>TRANSFORMERS (CLASS 47)</u>												
X	T-401	ANTENNA ASSEMBLY	ASSEMBLY OF COILS, TRIMMERS, SWITCHES & RESISTORS	-47222		1			T-7607855 G1			T-401
X	T-402	R.F. ASSEMBLY	ASSEMBLY OF COILS, TRIMMERS, SWITCHES & RESISTORS	-47224		1			T-7607859 G1			T-402
X	T-403	OSCILLATOR ASSEMBLY	ASSEMBLY OF COILS, TRIMMERS, SWITCHES & RESISTORS	-47220		1			T-7607857 G1			T-403
X	T-404	1ST I.F. TRANSFORMER	ASSEMBLY OF COILS, TRIMMERS & RESISTORS	-47218		1			T-7607847 G1			T-404
X	T-405	2ND I.F. TRANSFORMER	ASSEMBLY OF COILS, TRIMMERS & RESISTORS	-47214		1			T-7607848 G1			T-405
X	T-406	3RD I.F. TRANSFORMER	ASSEMBLY OF COILS, TRIMMERS & RESISTORS	-47212		1			T-7607849 G1			T-406
X	T-407	CW OSCILLATOR ASSEMBLY	ASSEMBLY OF COILS, TRIMMERS & RESISTORS	-47216A		1			P-7708206 G1			T-407
X	T-408	OUTPUT TRANSFORMER	250 VOLTS, 200 TO 3000 CYCLES, RATIO 3.84 TO 1 D.C. WDG. TAPS VOLTS AMPS. TURNS OHMS P1 1T02 250 .0185 3700 570 S1 3T04 86 965 55 TEST 1500 VOLTS, 60 CYCLES BETWEEN WINDINGS AND FROM WINDINGS TO CORE	-30820		1			L-382521			T-408, T-508
X	T-409	WAVE TRAP ASSEMBLY	ASSEMBLY OF CORE & COIL						T-7607939 G1			T-409
X	T-501	ANTENNA ASSEMBLY	ASSEMBLY OF COILS, TRIMMERS & RESISTORS	-47223A		1			T-7607866 G1			T-501

TABLE II (CONTINUED)										SPARE PARTS		
SPARE PARTS LIST BY SYMBOL DESIGNATION FOR RBM-5 SEMI-PORTABLE RADIO RECEIVER EQUIPMENT										SPARE PARTS		
BATTERY OR 60 CY. A.C. SUPPLY	SYMBOL DESIG.	FUNCTION	DESCRIPTION	NAVY TYPE NUMBER	NAVY SPEC. DR. DRAWING NUMBER	MFR. NO.	MFR. DESIG.	SPECIAL TOL. RATING OR MODIFICATION	CONTRACTOR'S DRAWING AND PART NUMBER	BOX NUMBER	QUANTITY	ALL SYMBOL DESIGNATIONS INVOLVED
	TRANSFORMERS (CLASS 47) CONTINUED											
X	T-502	R.F. ASSEMBLY	ASSEMBLY OF COILS, TRIMMERS & RESISTORS	-47225A		1			T-7607860 G1			T-502
X	T-503	OSCILLATOR ASSEMBLY	ASSEMBLY OF COILS, TRIMMERS & RESISTORS	-47221		1			T-7607858 G1			T-503
X	T-504	1ST I.F. TRANSFORMER	ASSEMBLY OF COILS, TRIMMERS & RESISTORS	-47219		1			T-7607850 G1			T-504
X	T-505	2ND I.F. TRANSFORMER	ASSEMBLY OF COILS, TRIMMERS & RESISTORS	-47215		1			T-7607851 G1			T-505
X	T-506	3RD I.F. TRANSFORMER	ASSEMBLY OF COILS, TRIMMERS & RESISTORS	-47213		1			T-7607852 G1			T-506
X	T-507	CW OSCILLATOR ASSEMBLY	ASSEMBLY OF COILS, TRIMMERS & RESISTORS	-47217		1			P-7708206 G2			T-507
X	T-508	OUTPUT TRANSFORMER	SAME AS T-408	-30820								
X	T-901	TRANSFORMER	60 CYCLE, SINGLE PHASE WDG. TERM. VOLTS AMPS TURNS OHMS PRI 1T02 115 260 2 S1 4T05 205 0.1 29 0.15 S2 7-6-8 5 3 12/6 0.053 S3 9-3-10 12.1 2.9 1350/675 100	-30840		23	U-5803B		P-7708333 P1			T-901
X	T-1001	FILAMENT TRANSFORMER	9.0 VA., 60 CYCLE WDG. TERM. VOLTS AMPS TURNS OHMS PRI. 1T02 115 0.1 1470 60 SEC. 3T04 12 0.74 172 0.85 TEST 1500 VOLTS, 60 CYCLE BETWEEN WINDINGS AND CASE	-30821		1			L-382580			T-1001
			<u>VACUUM TUBES (CLASS 38)</u>									
X	V-401	R.F. AMPLIFIER VACUUM TUBE	TRIPLE GRID SUPER CONTROL AMPLIFIER, BULB: METAL SHELL, MT-8. BASE: SMALL WAFER OCTAL 8 PIN. HEATER RATING: 12.6 A.C. OR D.C. VOLTS, 0.15 AMP.	-12SK7	JAN 1	6	12SK7		T-7608018 P617	1	1	V-401, V-409, V-509
X	V-402	1ST DETECTO VACUUM TUBE	HIGH FREQUENCY AMPLIFIER, SINGLE ENDED METAL TYPE WITH SEMI REMOTE CUT-OFF. BULB: METAL SHELL MT-8. BASE: SMALL WAFER OCTAL 8 PIN. HEATER RATING: 12.6 A.C. OR D.C. VOLTS, 0.15 AMP.	-12SG7	JAN 1	6	12SG7		T-7608018 P618	1	2	V-402, V-404, V-405, V-501, V-502, V-504, V-505

TABLE 11 (CONTINUED)

PARTS AND SPARE PARTS LIST BY SYMBOL DESIGNATION FOR RBM-5 SEMI-PORTABLE RADIO RECEIVER EQUIPMENT

BATTERY OR 60 CY. A.C. SUPPLY	SYMBOL DESIG.	FUNCTION	DESCRIPTION	NAVY TYPE NUMBER	NAVY SPEC. OR DRAWING NUMBER	MFR.	MFR. DESIG.	SPECIAL TOL. RATING OR MODIFICATION	CONTRACTOR'S DRAWING AND PART NUMBER	SPARE PARTS		
										BOX NUMBER	QUANTITY	ALL SYMBOL DESIGNATIONS INVOLVED
VACUUM TUBES (CLASS 38) CONTINUED												
X	V-403	H.F. OSCILLATOR VACUUM TUBE	TRIPLE GRID DETECTOR AMPLIFIER BULB: METAL SHELL, MT-8. BASE: SMALL WAFER OCTAL, 8 PIN. HEATER RATING: 12.6 A.C. OR D.C. VOLTS, 0.15 AMP.	-12SJ7	JAN 1	6	12SJ7		T-7608018 P619	1	2	V-403, V-408, V-410, V-503, V-508, V-510
X	V-404	1ST I.F. AMPLIFIER VACUUM TUBE	SAME AS V-402	-12SG7							1	
X	V-405	2ND I.F. AMPLIFIER VACUUM TUBE	SAME AS V-402	-12SG7							1	
X	V-406	2ND DETECTOR AND NOISE PEAK LIMITER VACUUM TUBE	DUPLEX DIODE. BULB: METAL SHELL MT-8. BASE: SMALL WAFER OCTAL, 7 PIN. HEATER RATING: 12.6 A.C. OR D.C. VOLTS, 0.15 AMP.	-12H6	JAN 1	6	12H6		T-7608018 P622	1	1	V-406, V-407, V-506, V-507
X	V-407	A.V.C. DIODE VACUUM TUBE	SAME AS V-406	-12H6							1	
X	V-408	C.W. OSCILLATOR VACUUM TUBE	SAME AS V-403	-12SJ7							1	
X	V-409	1ST A.F. AMPLIFIER VACUUM TUBE	SAME AS V-401	-12SK7							1	
X	V-410	2ND A.F. AMPLIFIER VACUUM TUBE	SAME AS V-403	-12SJ7							1	
X	V-411	3RD A.F. AMPLIFIER VACUUM TUBE	BEAM POWER AMPLIFIER PENTODE BULB: METAL SHELL, MT-8. BASE: SMALL WAFER OCTAL, 7 PIN. HEATER RATING: 12.6 A.C. OR D.C. VOLTS, 0.15 AMP.	-12A6	JAN 1	6	12A6		T-7608018 P627	1	1	V-411, V-511
X	V-501	R.F. AMPLIFIER VACUUM TUBE	SAME AS V-402	-12SG7							1	
X	V-502	1ST DETECTOR VACUUM TUBE	SAME AS V-402	-12SG7							1	
X	V-503	H.F. OSCILLATOR VACUUM TUBE	SAME AS V-403	-12SJ7							1	
X	V-504	1ST I.F. AMPLIFIER VACUUM TUBE	SAME AS V-402	-12SG7							1	
X	V-505	2ND I.F. AMPLIFIER VACUUM TUBE	SAME AS V-402	-12SG7							1	
X	V-506	2ND DETECTOR AND NOISE PEAK LIMITER VACUUM TUBE	SAME AS V-406	-12H6							1	
X	V-507	A.V.C. DIODE VACUUM TUBE	SAME AS V-406	-12H6							1	
X	V-508	C.W. OSCILLATOR VACUUM TUBE	SAME AS V-403	-12SJ7							1	
X	V-509	1ST A.F. AMPLIFIER VACUUM TUBE	SAME AS V-401	-12SK7							1	
X	V-510	2ND A.F. AMPLIFIER VACUUM TUBE	SAME AS V-403	-12SJ7							1	

10-35

TABLE II (CONTINUED)

PARTS AND SPARE PARTS LIST BY SYMBOL DESIGNATION FOR RBM-5 SEMI-PORTABLE RADIO RECEIVER EQUIPMENT

SPARE PARTS

BATTERY OR 60 CY. A.C. SUPPLY	SYMBOL DESIG.	FUNCTION	DESCRIPTION	NAVY TYPE NUMBER	NAVY SPEC. OR DRAWING NUMBER	MFR.	MFR. DESIG.	SPECIAL TOL. RATING OR MODIFICATION	CONTRACTOR'S DRAWING AND PART NUMBER	BOX NUMBER	QUANTITY	ALL SYMBOL DESIGNATIONS INVOLVED
X	V-511	3RD A.F. AMPLIFIER VACUUM TUBE	SAME AS V-411	-12A6							1	
X	V-901	RECTIFIER TUBE	FULL WAVE HIGH VACUUM RECTIFIER, GLASS BASE MOULDED, MEDIUM OCTAL 5 PIN, HEATER CURRENT 3 AMPS. AT 5 V.A.C.	-5U4G	RE13A600D	13	5U4G		T-7607615 PS6			V-901
<u>WIRES AND INTERCONNECTING CABLES (CLASS 62)</u>												
X	W-1401	CABLE, DYNAMOTOR TO M.F. RECEIVER	5 CONDUCTOR OR 8 CONDUCTOR						T-7607875 G3 OR T-7610064 G3			W-1401, W-1501 DWG. M-7408100 P1 OR M-7409484 P1
X	W-1501	CABLE, DYNAMOTOR TO H.V. RECEIVER	5 CONDUCTOR OR 8 CONDUCTOR						T-7607875 G4 OR T-7610074 G4			
X	W-1601	CABLE, BATTERY TO DYNAMOTOR	2 CONDUCTOR OR 4 CONDUCTOR						T-7607875 G2 OR T-7610074 G2			W-1601, W-1701, W-1801 DWG. M-7408100 P2 OR M-7409484 P2
X	W-1701	CABLE, BATTERY TO BATTERY	2 CONDUCTOR OR 4 CONDUCTOR						T-7607875 G1 OR T-7610074 G1			
X	W-1801	CABLE, CHARGING GENERATOR TO DYNAMOTOR	2 CONDUCTOR OR 4 CONDUCTOR						T-7607875 G5 OR T-7610074 G5			
X	W-1901	CABLE, POWER INPUT M.F. RECEIVER	5 CONDUCTOR OR 8 CONDUCTOR						T-7607875 G6 OR T-7610074 G6			W-1901, W-2001 DWG. M-7408100 P1 OR M-7409484 P1
X	W-2001	CABLE, POWER INPUT H.F. RECEIVER	5 CONDUCTOR OR 8 CONDUCTOR						T-7607875 G7 OR T-7610074 G7			
<u>VACUUM TUBE SOCKETS (CLASS 49)</u>												
X	X-401	R.F. AMPLIFIER	REPLACEMENT TYPE, OCTAL, STEATITE	-49373	RE49AA313A	14	RSS-9M		P-7708222 P4			X-401, X-402, X-403, X-404, X-405, X-406, X-407, X-408, X-409, X-410, X-411, X-501, X-502, X-503, X-504, X-505, X-506, X-507, X-508, X-509, X-510, X-511
X	X-402	1ST DET. SOCKET	SAME AS X-401	-49373								
X	X-403	H.F. OSC. SOCKET	SAME AS X-401	-49373								
X	X-404	1ST I.F. AMPLIFIER SOCKET	REPLACEMENT TYPE, OCTAL, STEATITE (WITH SHIELD)	-49373	RE49AA313A	14	RSS-9M		M-7408064 G2			

TABLE II (CONTINUED)

PARTS AND SPARE PARTS LIST BY SYMBOL DESIGNATION FOR RBM-S SEMI-PORTABLE RADIO RECEIVER EQUIPMENT

SPARE PARTS

BATTERY OR 60 CY. A.C. SUPPLY	SYMBOL DESIG.	FUNCTION	DESCRIPTION	NAVY TYPE NUMBER	NAVY SPEC. OR DRAWING NUMBER	MFR. DESIG.	SPECIAL TOL. RATING OR MODIFICATION	CONTRACTOR'S DRAWING AND PART NUMBER	BOX NUMBER	QUANTITY	ALL SYMBOL DESIGNATIONS INVOLVED
X	X-404B	SHIELD	TUBE SOCKET, CONTACT SHIELD					K-7810428 P1			X-404B
X	X-405	2ND I.F. AMPLIFIER SOCKET	SAME AS X-401	-49373							
X	X-406	2ND DET. AND NOISE PEAK LIMITER SOCKET	SAME AS X-401	-49373							
X	X-406A	CONTACT	TUBE SOCKET, CONTACT			14		P-7708222 P5			X-406A
X	X-407	A.V.C. DIODE SOCKET	SAME AS X-401	-49373							
X	X-408	CW OSC. SOCKET	SAME AS X-401	-49373							
X	X-409	1ST A.F. AMPLIFIER SOCKET	SAME AS X-401	-49373							
X	X-410	2ND A.F. AMPLIFIER SOCKET	SAME AS X-401	-49373							
X	X-411	3RD A.F. AMPLIFIER SOCKET	SAME AS X-401	-49373							
X	X-501	R.F. AMPLIFIER SOCKET	SAME AS X-404	-49373							
X	X-502	1ST DET. SOCKET	SAME AS X-401	-49373							
X	X-503	H.F. OSC. SOCKET	SAME AS X-401	-49373							
X	X-504	1ST I.F. AMPLIFIER SOCKET	SAME AS X-404	-49373							
X	X-505	2ND I.F. AMPLIFIER SOCKET	SAME AS X-404	-49373							
X	X-506	2ND DET. AND NOISE PEAK LIMITER SOCKET	SAME AS X-401	-49373							
X	X-507	A.V.C. DIODE SOCKET	SAME AS X-401	-49373							
X	X-508	CW OSC. SOCKET	SAME AS X-401	-49373							
X	X-509	1ST A.F. AMPLIFIER SOCKET	SAME AS X-401	-49373							
X	X-510	2ND A.F. AMPLIFIER SOCKET	SAME AS X-401	-49373							
X	X-511	3RD A.F. AMPLIFIER SOCKET	SAME AS X-401	-49373							
X	X-901	SOCKET FOR RECTIFIER TUBE	SAME AS X-401	-49373							X-901

10-57

TABLE III
PARTS LIST BY NAVY TYPE NUMBERS FOR MODEL RBM-5 SEMI PORTABLE RADIO RECEIVER EQUIPMENT

QUANTITY	NAVY TYPE NUMBER	ALL SYMBOL DESIGNATIONS INVOLVED	QUANTITY	NAVY TYPE NUMBER	ALL SYMBOL DESIGNATIONS INVOLVED	QUANTITY	NAVY TYPE NUMBER	ALL SYMBOL DESIGNATIONS INVOLVED
MISCELLANEOUS (CLASS 10)			FUSES (CLASS 28)			TRANSFORMERS & REACTORS (CLASS 30) CONTINUED		
1		E-601	1		F-601A	1		L-407
9		I-401, I-402, I-501, I-502, I-601, I-901A, I-1001A, I-1002A, I-1003A	6		F-601B, F-602B, F-603B, F-604B F-605B, F-606B	1		L-408
4		I-901B, I-1001B, I-1002B, I-1003B	2		F-602A, F-604A, F-603A, F-605A	1		L-409
METERS (CLASS 22)			2		F-901A, F-902A	1		L-410
1	MR258015DC VV	M-601	4		F-901B, F-902B, F-1001B, F-1002B	1		L-411
SWITCHES (CLASS 24)			2		F-1001A, F-1002A	1		L-412
2	-24002	S-404, S-504	RELAYS (CLASS 29)			1		L-413
7	-24115	S-604, S-605, S-901, S-902, S-1004, S-1005, S-1006	1		K-601	1		L-414
2	-24117	S-1001A, S-1001B, S-1002A, S-1002B	1		K-1001	1		L-415
1	-24118	S-606	TRANSFORMERS & REACTORS (CLASS 30)			1		L-416
4	-24121	S-601A, S-601B, S-602A, S-602B	2	-30816	L-602, L-604	1		L-417
11		S-401A, S-401B, S-401C, S-401D, S-401E, S-401F, S-501A, S-501B, S-501C, S-501D, S-501F	2	-30818	L-901, L-902	4		L-418
2		S-401F, S-501E	2	-30820	T-408, T-508	1		L-419
2		S-401H, S-501G	1	-30821	T-1001	1		L-420
2		S-402A, S-402B, S-502A, S-502B	1	-30840	T-901	1		L-421, L-422, L-521, L-522
2		S-403A, S-403B, S-503A, S-503B	1		L-401	1		L-423
1		S-501H	1		L-402	1		L-501
2		S-603A, S-603B, S-1003A, S-1003B	1		L-403	1		L-502
			1		L-404	1		L-503
			1		L-405	1		L-504
			1		L-406	1		L-505
						1		L-506
						1		L-507
						1		L-508
						1		L-509

68-101

TABLE III (CONTINUED)								
PARTS LIST BY NAVY TYPE NUMBERS FOR MODEL RBM-4 SEMI-PORTABLE RADIO RECEIVER EQUIPMENT								
QUANTITY	NAVY TYPE NUMBER	ALL SYMBOL DESIGNATIONS INVOLVED	QUANTITY	NAVY TYPE NUMBER	ALL SYMBOL DESIGNATIONS INVOLVED	QUANTITY	NAVY TYPE NUMBER	ALL SYMBOL DESIGNATIONS INVOLVED
<u>TRANSFORMERS & REACTORS (CLASS 30) CONTINUED</u>			<u>TRANSFORMERS (CLASS 47) CONTINUED</u>			<u>CAPACITORS (CLASS 48) CONTINUED</u>		
1	L-510		1	-47216	T-407	2	-481070-B10	C-597, C-598
1	L-511		1	-47217	T-507	1	-481149-D3	C-471
1	L-512		1	-47218	T-404	1	-481151-D1	C-425
1	L-513		1	-47219	T-504	1	-481323-D7	C-489
1	L-514		1	-47220	T-403	1	-481454-5	C-530
1	L-515		1	-47221	T-503	1	-481455-5	C-531
1	L-516		1	-47222	T-401	1	-481456-5	C-432, C-532
1	L-517		1	-47223A	T-501	1	-481457-5	C-529
1	L-518		1	-47224	T-402	1	-481460-5	C-430
1	L-519		1	-47225A	T-502	1	-481461-5	C-429
1	L-520		<u>CAPACITORS (CLASS 48)</u>			3	-481465-10	C-424A, C-424B, C-901A, C-901B, C-1001A, C-1001B
2	L-601, L-603		5	-48591-B10	C-491, C-504, C-505, C-518, C-579	6	-481466	C-444A, C-444B, C-444C, C-449A, C-449B, C-449C, C-468A, C-468B, C-468C, C-544A, C-544B, C-544C, C-549A, C-549B, C-549C, C-568A, C-568B, C-568C
<u>VACUUM TUBES (CLASS 38)</u>			13	-48674-B10	C-423, C-437, C-456, C-469, C-470, C-477, C-478, C-523, C-537, C-556, C-569, C-570, C-577	4	-481469	C-462, C-474, C-562, C-574
1	-5U4G	V-931	9	-48710-D10	C-406, C-484, C-485, C-487, C-488, C-584, C-585, C-587, C-592	2	-481470	C-475, C-575
2	-12A6	V-411, V-511	1	-48771-B10	C-467	2	-481471	C-601, C-685
4	-12H6	V-406, V-407, V-506, V-507	5	-48771-B20	C-403, C-404, C-405, C-506, C-591	2	-481480-10	C-483, C-578
7	-12SG7	V-402, V-404, V-405, V-501, V-502, V-504, V-505	3	-48771-D20	C-486, C-583, C-586	1	-481483	C-902
6	-12SJ7	V-403, V-408, V-410, V-503, V-508, V-510	2	-48783-D5	C-493, C-589	1	-481487-D1	C-427
3	-12SK7	V-401, V-409, V-509	3	-48840-D7	C-479, C-588, C-593	1	-481488-D1	C-428
<u>TRANSFORMERS (CLASS 47)</u>			26	-48848-B10	C-407, C-438, C-443, C-448, C-457, C-459, C-461, C-466, C-476, C-481, C-482, C-494, C-508, C-538, C-543, C-548, C-557, C-559, C-561, C-566, C-576, C-581, C-582, C-594, C-596, C-603	1	-481489-D3	C-442, C-446, C-447, C-452, C-453
1	-47212	T-406	5	-48895-B10	C-402, C-454, C-455, C-554, C-555	4	-481490-B5	C-463, C-465, C-563, C-565
1	-47213	T-506	3	-481037-B10	C-418, C-480, C-580	5	-481491-B5	C-464, C-495, C-564, C-595, C-602
1	-47214	T-405				1	-481492-D1	C-525
1	-47215	T-505						

TABLE III
PARTS LIST BY NAVY TYPE NUMBERS FOR MODEL RBM-4 SEMI PORTABLE RADIO RECEIVER EQUIPMENT

QUANTITY	NAVY TYPE NUMBER	ALL SYMBOL DESIGNATIONS INVOLVED	QUANTITY	NAVY TYPE NUMBER	ALL SYMBOL DESIGNATIONS INVOLVED	QUANTITY	NAVY TYPE NUMBER	ALL SYMBOL DESIGNATIONS INVOLVED
<u>CAPACITORS (CLASS 48) CONTINUED</u>			<u>CAPACITORS (CLASS 48) CONTINUED</u>			<u>RESISTORS (CLASS 63) CONTINUED</u>		
1	481493-D1	C-526	4		C-804, C-806, C-903, C-904 FOR REPLACEMENTS USE NAVY TYPE NUMBER 481249	1	-63355	R-532
1	481494-D1	C-527				12	-63360	R-401, R-419, R-435, R-441, R-447, R-453, R-454, R-501, R-535, R-541, R-547, R-573
1	481495-D1	C-528						
6	481496-D3	C-541, C-542, C-546, C-547, C-552, C-553			<u>JACKS AND RECEPTACLES (CLASS 49)</u>	9	-63360	R-402, R-418, R-422, R-438, R-460, R-502, R-518, R-522, R-538
1	481498-B10	C-567	6	49025B	J-403, J-503, J-601, J-602, J-1004, J-1005	4	-63360	R-404, R-412, R-420, R-515
1	481498-D3	C-571	3	49036	J-605, J-902, J-1008	9	-63360	R-405, R-417, R-421, R-425, R-505, R-516, R-517, R-521, R-525
1	481534-D1	C-441	7	49043	J-405, J-505, J-606, J-607, J-903, J-1006, J-1010	3	-63360	R-410, R-510, R-548
1	481614-D1	C-426	4	49053	J-608, J-609, J-1007, J-1009	2	-63360	R-411, R-511
1	481808-5	C-431	2	49169	J-1301, J-1302	6	-63360	R-413, R-426, R-427, R-513, R-526, R-527
2	481825	C-439A, C-439B, C-439C, C-539A, C-539B, C-539C	2	49179	J-603, J-604	1	-63360	R-415
6	482057-10	C-413A, C-413B, C-450A, C-450B, C-458A, C-458B, C-513A, C-513B, C-550A, C-550B, C-558A, C-558B	2		J-401, J-501	5	-63360	R-416, R-424, R-504, R-520, R-524
2	482058-10	C-460A, C-460B, C-560A, C-560B	2		J-402, J-502	4	-63360	R-423, R-431, R-460, R-569
1	482059	C-524	7		J-404, J-504	8	-63360	R-428, R-436, R-457, R-462, R-470, R-528, R-536, R-562
1		C-401	3		J-405A, J-505A, J-606A, J-607A, J-903A, J-1006A, J-1010A	4	-63360	R-429, R-440, R-442, R-529
32		C-408, C-409, C-410, C-411, C-414, C-415, C-416, C-417, C-419, C-420, C-421, C-422, C-433, C-434, C-435, C-436, C-508, C-509, C-510, C-511, C-514, C-515, C-516, C-517, C-519, C-520, C-521, C-522, C-533, C-534, C-535, C-536	4		J-605A, J-902A, J-1008A	5	-63360	R-439, R-450, R-459, R-539, R-550
			4		J-608A, J-609A, J-1007A, J-1009A	5	-63360	R-448, R-471, R-477, R-570, R-571
			2		J-901, J-902	3	-63360	R-449, R-474, R-549
			2		J-1001, J-1003	2	-63360	R-458, R-468
2		C-412A, C-412B, C-412C, C-412D, C-512A, C-512B, C-512C, C-512D			<u>RESISTORS (CLASS 63)</u>	6	-63360	R-465, R-466, R-540, R-542, R-565, R-566
6		C-440A, C-440B, C-445A, C-445B, C-451A, C-451B, C-540A, C-540B, C-545A, C-545B, C-551A, C-551B	4	-63288	R-463, R-464, R-563, R-564	1	-63360	R-473
2		C-472, C-572	2	-63355	R-403, R-503	1	-63360	R-506
1		C-473	1	-63355	R-414	1	-63360	R-512
1		C-501	3	-63355	R-430, R-452, R-530	2	-63360	R-519, R-523
1		C-573	3	-63355	R-432, R-467, R-567	1	-63360	R-531
			2	-63355	R-434, R-534			
			1	-63355	R-445			
			2	-63355	R-461, R-552			
			3	-63355	R-475, R-545, R-575			
			1	-63355	R-514			

10-40

TABLE III (CONTINUED)

PARTS LIST BY NAVY TYPE NUMBERS FOR MODEL RBM-5 SEMI PORTABLE RADIO RECEIVER EQUIPMENT

QUANTITY	NAVY TYPE NUMBER	ALL SYMBOL DESIGNATIONS INVOLVED	QUANTITY	NAVY TYPE NUMBER	ALL SYMBOL DESIGNATIONS INVOLVED	QUANTITY	NAVY TYPE NUMBER	ALL SYMBOL DESIGNATIONS INVOLVED
<u>RESISTORS (CLASS 63) CONTINUED</u>								
4	-63474	R-443, R-472, R-543, R-572						
4	-63474	R-444, R-476, R-544, R-576						
1	-63678-5	R-451						
1	-63678-10	R-406						
3	-63678-10	R-407, R-455, R-456						
1	-63678-10	R-408						
4	-63678-10	R-409, R-551, R-558, R-568						
1	-631182	R-901						
2	-631217	R-446, R-546						
1	-631218	R-601						
1	-631219	R-537						
1	-631220	R-437						
4	-631221	R-433A, R-433B, R-533A, R-533B						

10-41

TABLE IV
 APPLICABLE COLOR CODES AND MISCELLANEOUS DATA
 MODEL RBM-5 SEMI-PORTABLE RADIO RECEIVER EQUIPMENT

COLOR CODE IN MMFD. FOR CAPACITORS

COLOR	1ST DIGIT A	2ND DIGIT B	CIPHERS C
BLACK	-	0	.0
BROWN	1	1	0
RED	2	2	00
ORANGE	3	3	000
YELLOW	4	4	0000
GREEN	5	5	00000
BLUE	6	6	000000
PURPLE	7	7	0000000
GRAY	8	8	00000000
WHITE	9	9	--

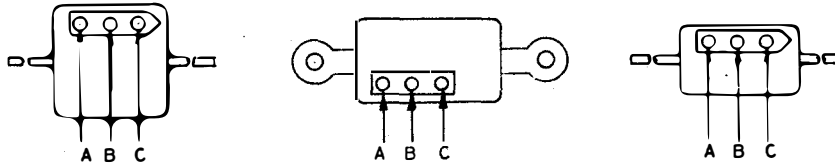

RCA COLOR CODED CAPACITORS CAPACITY IN MMFD.

VALUES DESIGNATE TOLERANCE BY COLOR

YELLOW ±20%

BLUE ±10%

BLACK ±5%

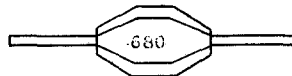

RMA COLOR CODE FOR RESISTORS

COLOR	1ST DIGIT A	2ND DIGIT B	CIPHERS C
BLACK	-	0	.0
BROWN	1	1	0
RED	2	2	00
ORANGE	3	3	000
YELLOW	4	4	0000
GREEN	5	5	00000
BLUE	6	6	000000
PURPLE	7	7	0000000
GRAY	8	8	00000000
WHITE	9	9	--

D- TOLERANCE CODE:

GOLD = 5%

SILVER = 10%

OMIT = 20%

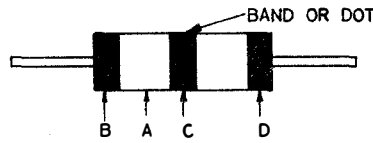

ORIGINAL COLOR ARRANGEMENT
 FOR
 AXIAL LEADS

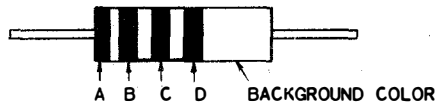

NEW COLOR ARRANGEMENT
 FOR
 AXIAL LEADS

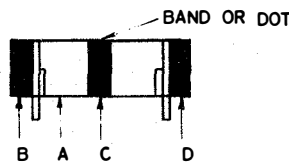

STANDARD COLOR ARRANGEMENT
 FOR
 RADIAL LEADS

TABLE V
LIST OF MANUFACTURERS
MODEL RBM-5 SEMI-PORTABLE RADIO RECEIVER EQUIPMENT

CODE NUMBER	MFR. PREFIX	NAME	ADDRESS
1	CAY	WESTINGHOUSE ELEC. & MFG. CO.	2519 WILKENS AVENUE BALTIMORE, MD.
2	CAW	AEROVOX CORP.	242 BELLEVILLE AVENUE NEW BEDFORD, MASS.
	CMR	MICAMOLD PRODUCTS CORP.	1087 FLUSHING AVENUE BROOKLYN, N. Y.
3	CRK	RADIO CONDENSER CO.	CAMDEN, N. J.
4	CBN	CENTRALAB	900 E. KEEFE AVENUE MILWAUKEE, WISC.
5	CED	CANNON ELECTRIC DEVELOPMENT CO.	5291 HUNBOGT ST. LOS ANGELES, CALIF.
6	CFW	F. W. SICKLES CO.	300 MAIN STREET SPRINGFIELD, MASS.
7	CMH	AMERICAN RADIO HARDWARE	476 BROADWAY NEW YORK, N. Y.
8	CTE	TELEPHONICS CORP.	350 W. 31ST STREET NEW YORK, N. Y.
9	CIR	INTERNATIONAL RESISTANCE CO.	401 NORTH BROAD STREET PHILADELPHIA, PA.
10	CBZ	ALLEN BRADLEY CO.	118 W. GREENFIELD AVENUE MILWAUKEE, WISC.
11	CMA	P. R. MALLORY & CO., INC.	1941 THOMAS STREET INDIANAPOLIS, IND.
12	CG	GENERAL ELECTRIC CO.	BRIDGEPORT, CONN.
13	CRC	RCA MANUFACTURING CO.	HARRISON, N. J.
14	CPH	AMERICAN PHENOLIC CORP.	1250 VAN BUREN STREET CHICAGO, ILL.
15	CLF	LITTELFUSE, INC.	4765 RAVENSWOOD AVENUE CHICAGO, ILL.
16	CJC	HOWARD B. JONES	CHICAGO, ILL.
17	CLT	LUNDQUIST TOOL & MFG. CO.	57 JACKSON STREET WORCESTER, MASS.
18	CRY	C. P. CLARE & CO.	4719 S. SUNNYSIDE AVENUE CHICAGO, ILL.
19	CHH	ARROW, HART & HEGEMAN ELEC. CO.	102 HAWTHORNE STREET HARTFORD, CONN.
20	CAE	CUTLER HAMMER, INC.	1333 W. ST. PAUL AVENUE MILWAUKEE, WISC.
21		DRAKE MFG. CO.	1713 W. HUBBARD STREET CHICAGO, ILL.
22		BRYANT ELECTRIC CO.	BRIDGEPORT, CONN.
23	CRP	RAYTHEON MFG. CO.	190 WILLOW STREET WALTHAM, MASS.

TABLE V (CONTINUED)
INDEX TO MANUFACTURERS

CODE NUMBER	MFR. PREFIX	NAME	ADDRESS
24	CCT	STROMBERG CARLSON TELEPHONE MFG. CO.	100 CARLSON ROAD ROCHESTER, N. Y.
25	CFA	BUSSMAN MFG. CO.	2538 W. UNIVERSITY AVE. ST LOUIS, MO.
26	CAN	SANGAMO ELECTRIC CO.	1935 FUNK STREET SPRINGFIELD, ILL.

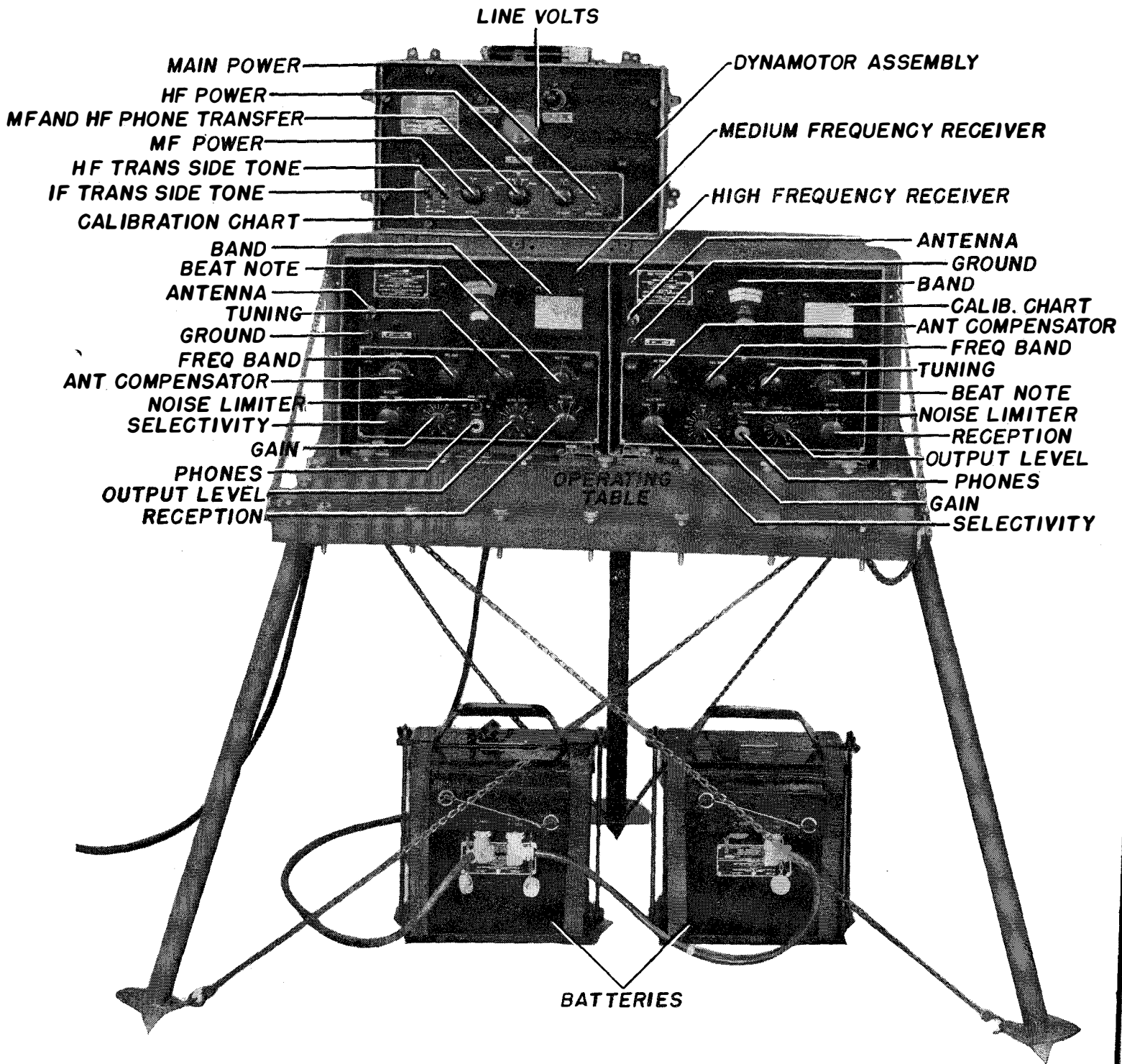

FIG. 3 NAVY MODEL RBM-5 SEMI-PORTABLE RADIO RECEIVING EQUIPMENT, PORTABLE COMPONENTS SET-UP FOR FIELD SERVICE (PHOTO C-5471).

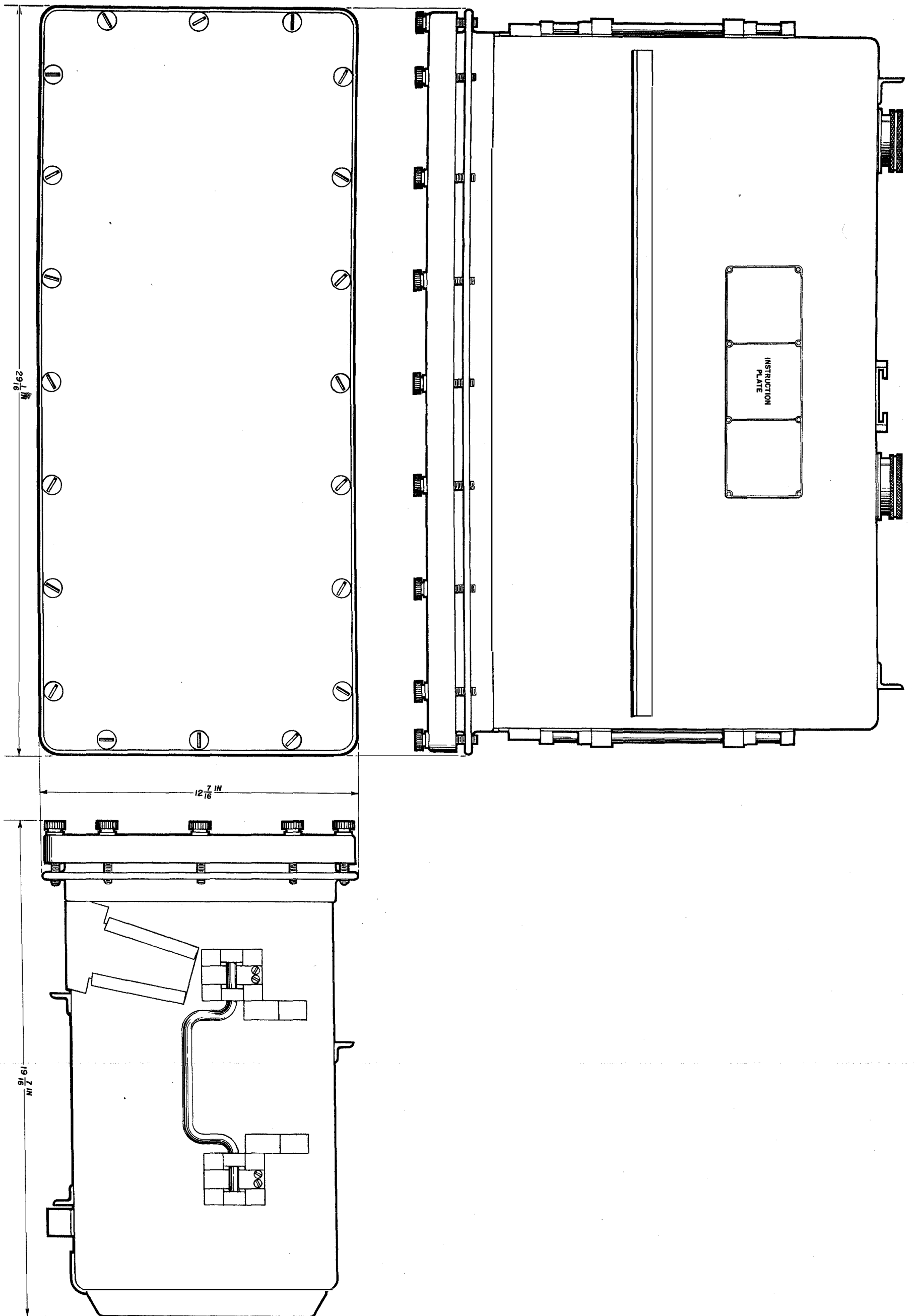
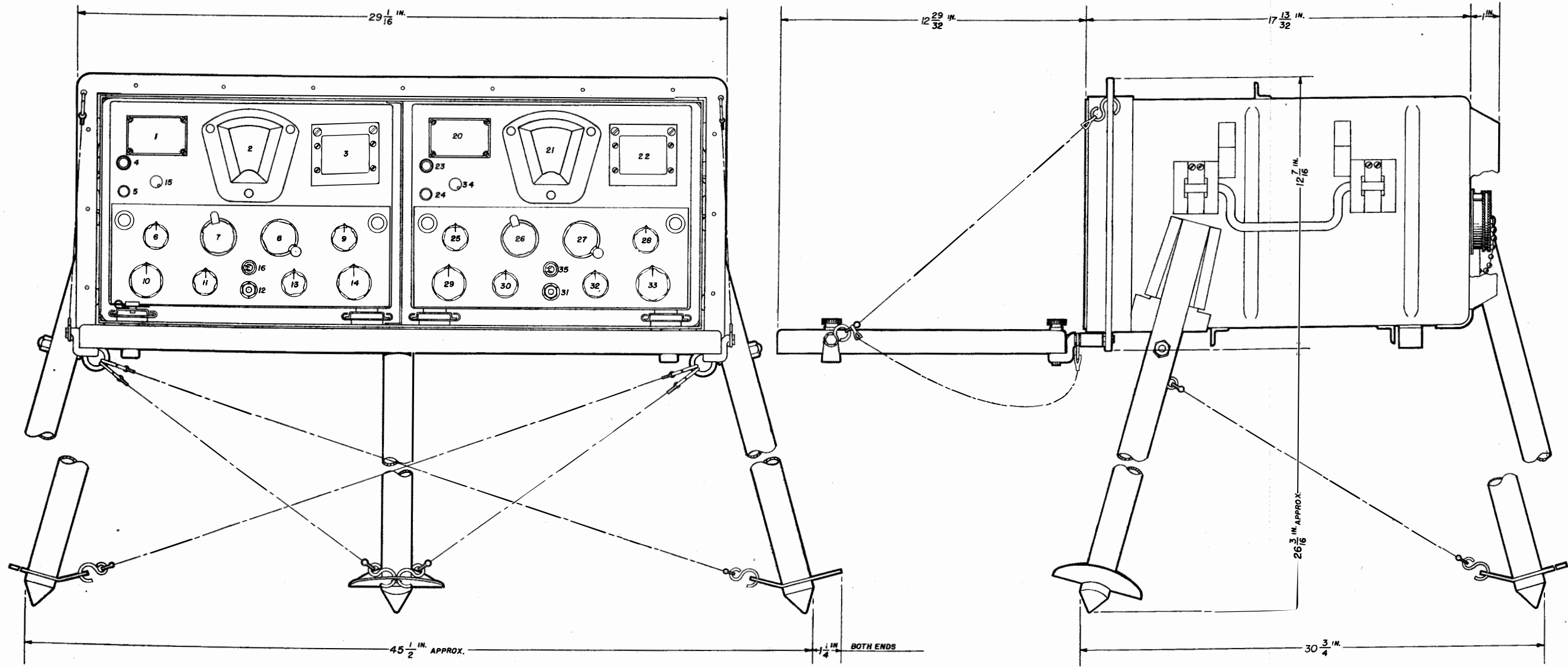

FIG. 48 RADIO RECEIVER ASSEMBLY, TYPE CAY-46078-A, RECEIVERS IN CASE, OUTLINE AND DIMENSIONS (DWG. T-7608638).



"LEGEND"

- | | |
|------------------------------|------------------------------|
| 1 M.F. INSTRUCTION PLATE | 20 H.F. INSTRUCTION PLATE |
| 2 M.F. TUNING DIAL | 21 H.F. TUNING DIAL |
| 3 M.F. CALIBRATION CHART | 22 H.F. CALIBRATION CHART |
| 4 M.F. ANTENNA POST | 23 H.F. ANTENNA POST |
| 5 M.F. GROUND POST | 24 H.F. GROUND POST |
| 6 M.F. ANT. COMP. CONTROL | 25 H.F. ANT. COMP. CONTROL |
| 7 M.F. RANGE SWITCH | 26 H.F. RANGE SWITCH |
| 8 M.F. TUNING CONTROL | 27 H.F. TUNING CONTROL |
| 9 M.F. BEAT NOTE CONTROL | 28 H.F. BEAT NOTE CONTROL |
| 10 M.F. SELECTIVITY CONTROL | 29 H.F. SELECTIVITY CONTROL |
| 11 M.F. GAIN CONTROL | 30 H.F. GAIN CONTROL |
| 12 M.F. PHONE JACK | 31 H.F. PHONE JACK |
| 13 M.F. OUTPUT LEVEL CONTROL | 32 H.F. OUTPUT LEVEL CONTROL |
| 14 M.F. RECEPTION CONTROL | 33 H.F. RECEPTION CONTROL |
| 15 M.F. DIAL LIGHT DIMMER | 34 H.F. DIAL LIGHT DIMMER |
| 16 M.F. NOISE LIMITER SWITCH | 35 H.F. NOISE LIMITER SWITCH |

FIG. 49 RADIO RECEIVER ASSEMBLY, TYPE CAY-46078-A, RECEIVERS IN OPERATION, OUTLINE AND DIMENSIONS (DWG. T-7613094).

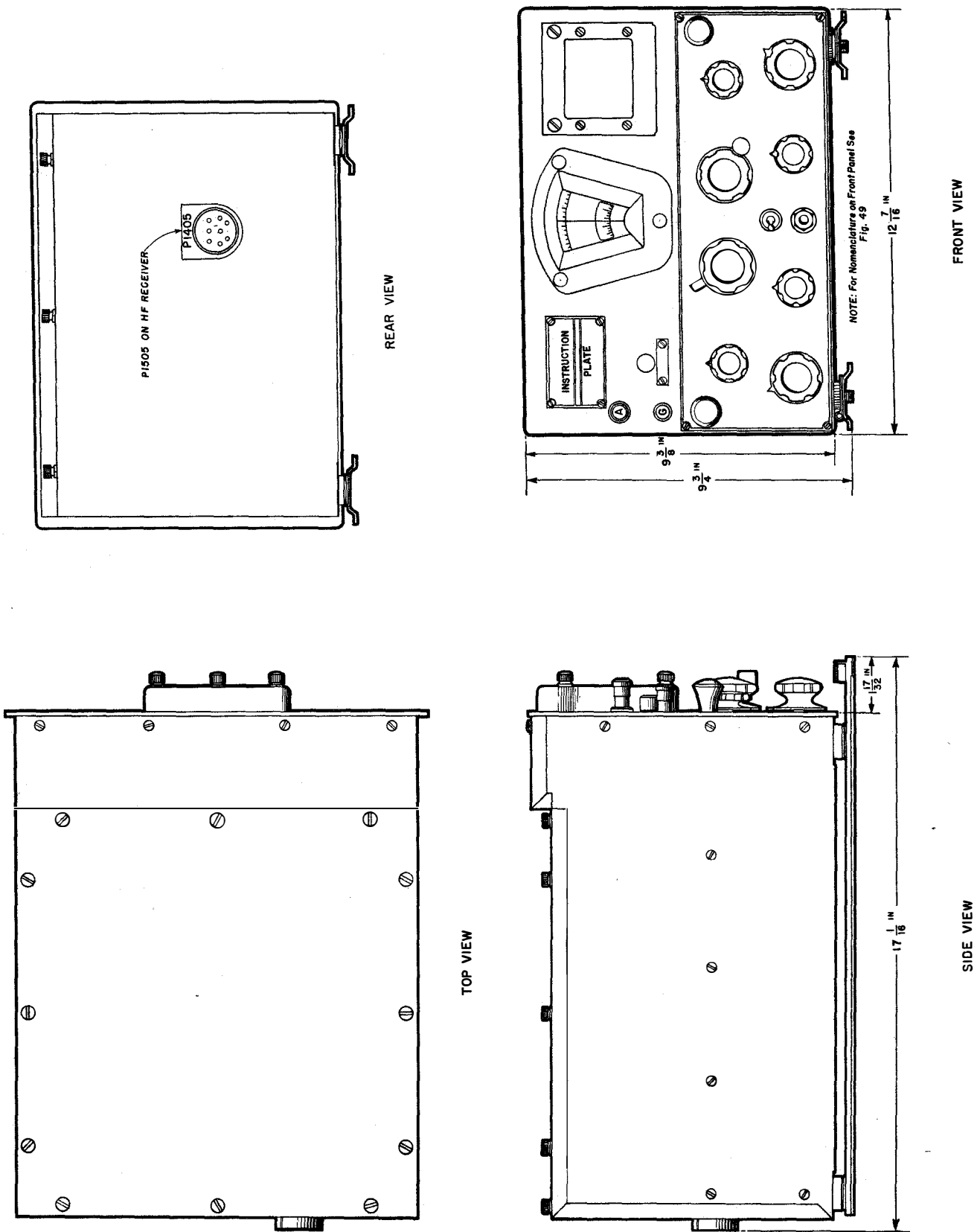

FIG. 50 MEDIUM FREQUENCY RECEIVER, TYPE CAY-46076-A, AND HIGH FREQUENCY RECEIVER, TYPE CAY-46077-A, OUTLINE AND DIMENSIONS (DWG. T-7613095).

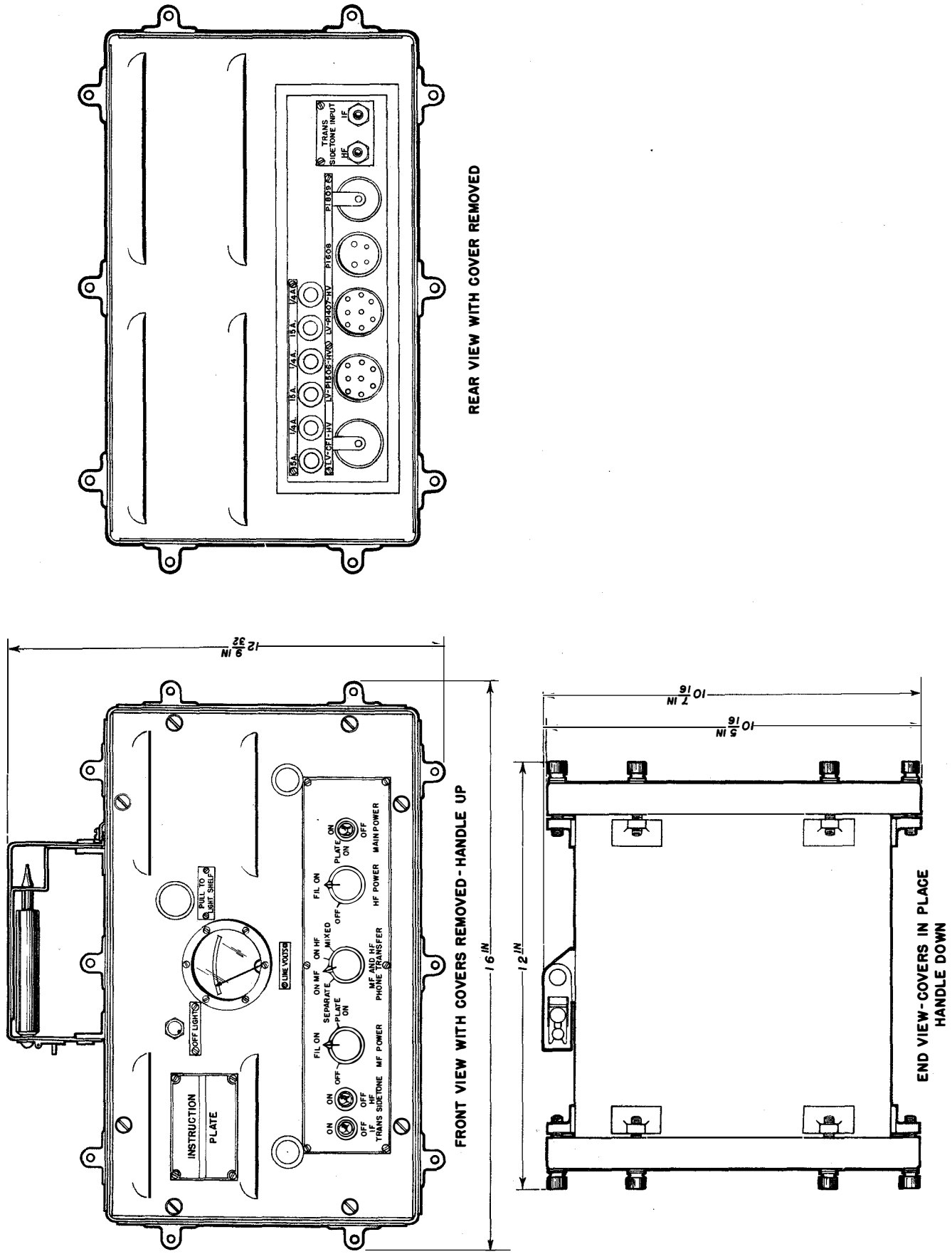

FIG. 51 DYNAMOTOR ASSEMBLY, TYPE CAY-21387-A, OUTLINE AND DIMENSIONS (DWG. P-7713084).

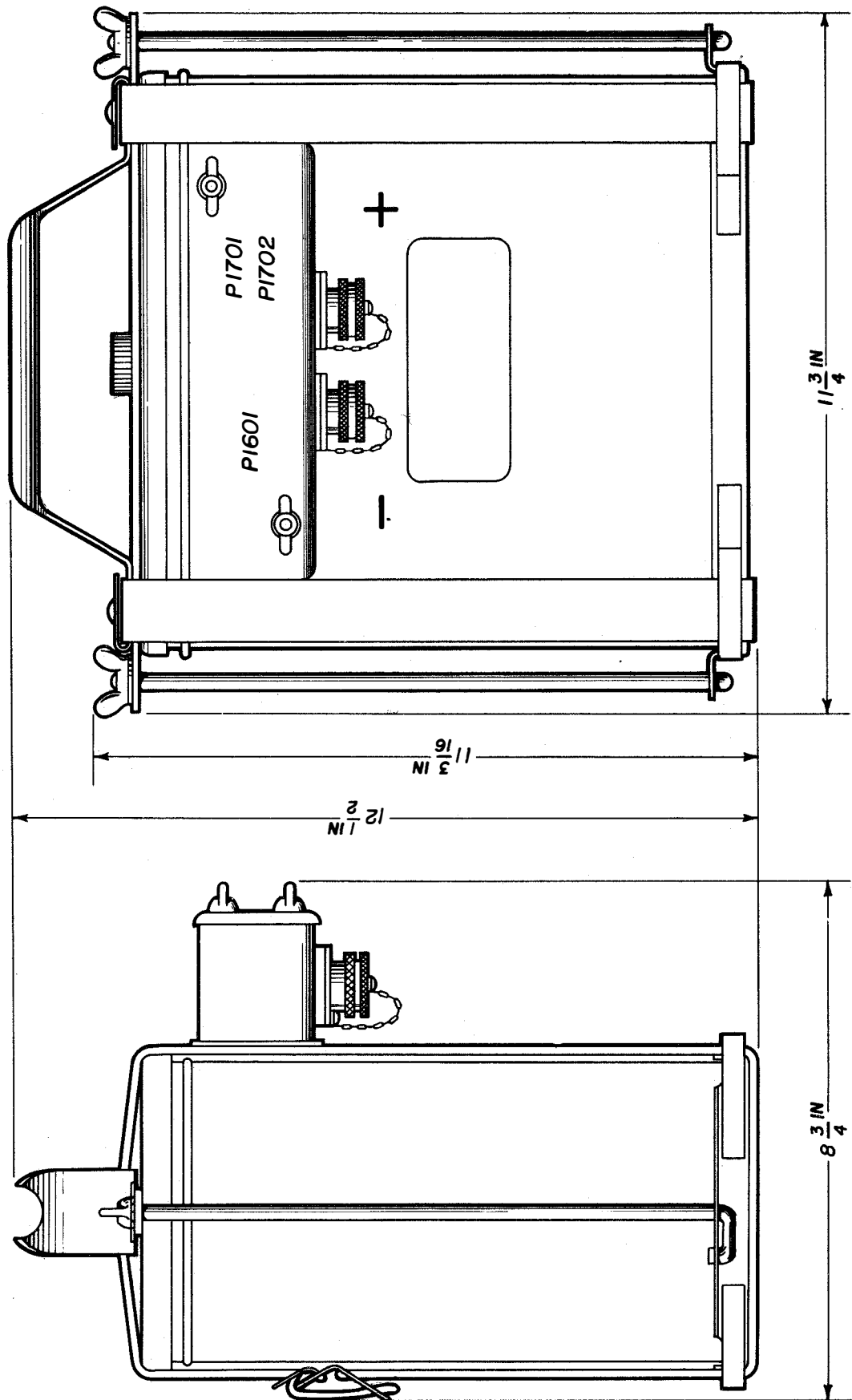

FIG. 52 PORTABLE STORAGE BATTERY, TYPE CES-19017, OUTLINE AND DIMENSIONS (Dwg. P-7708690).

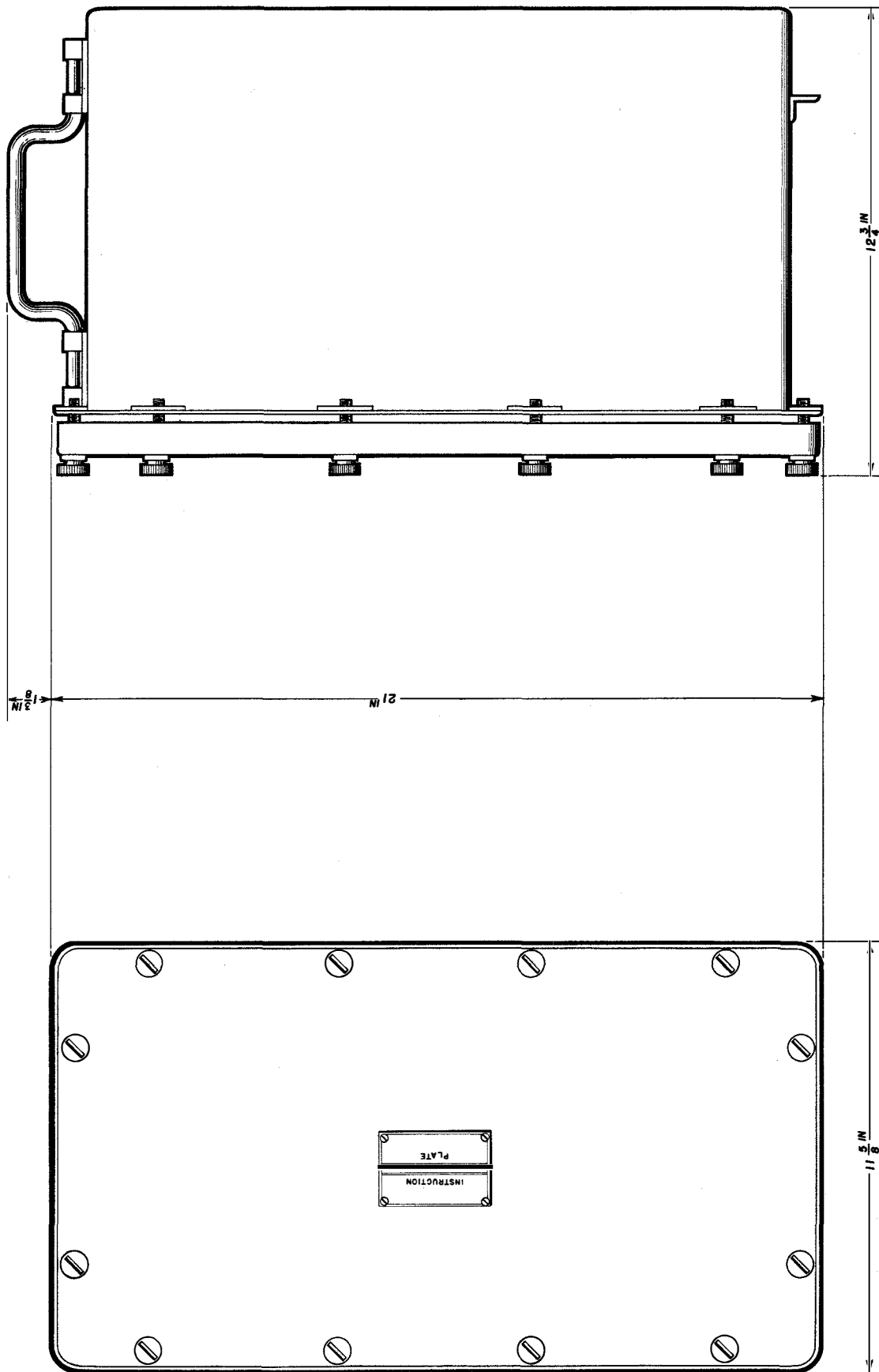

FIG. 53 MOBILE SPARE PARTS BOX, TYPE CAY-10095, OUTLINE AND DIMENSIONS (DWG. T-7613184).

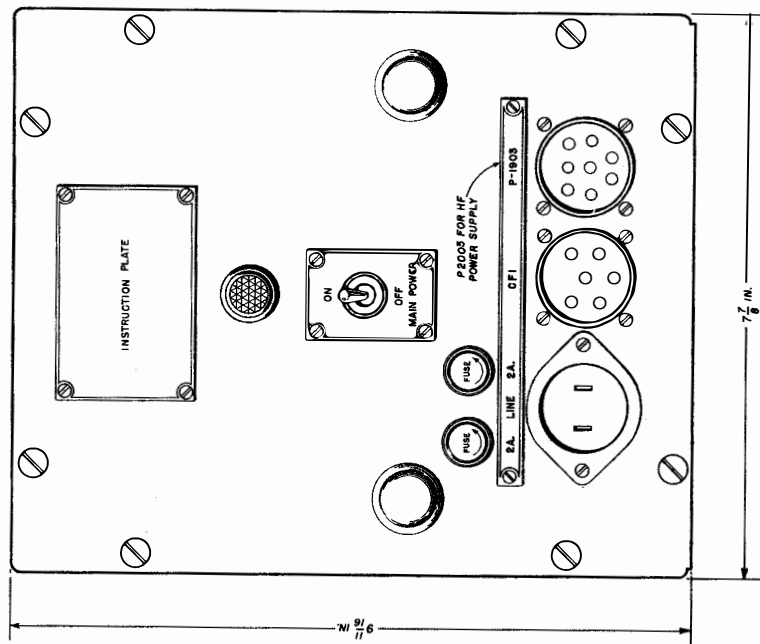
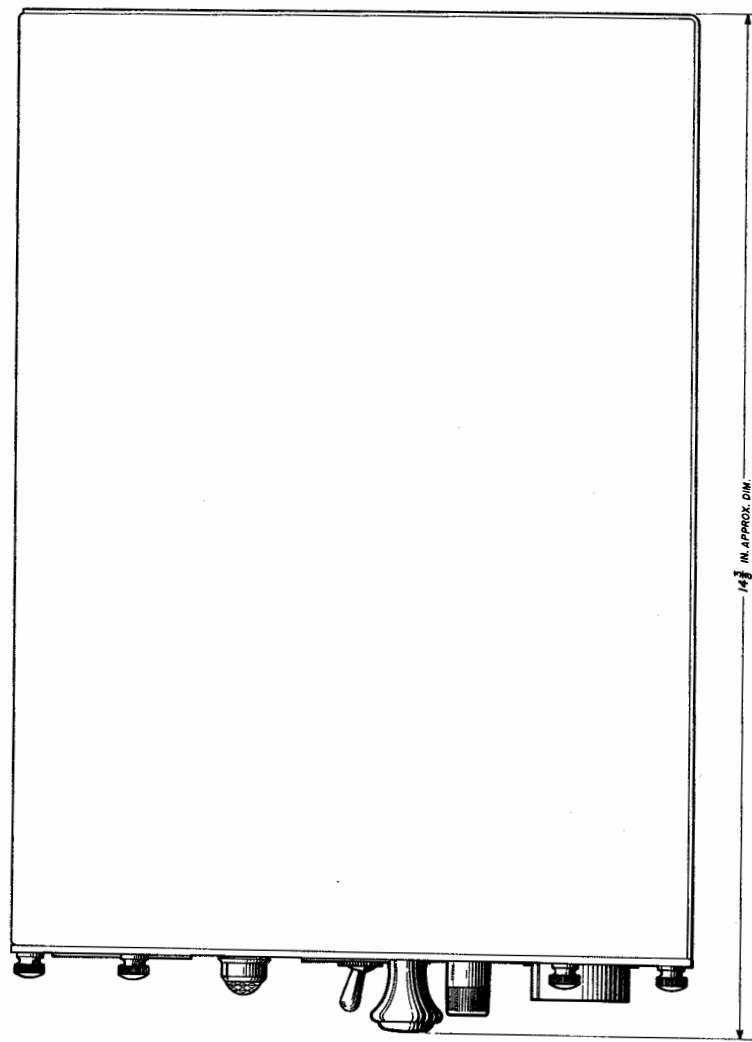

FIG. 54 RECTIFIER POWER UNIT, TYPE CAY-20086, FOR 115 VOLT, 60 CYCLE, A.C. OPERATION, OUTLINE AND DIMENSIONS (DWG. T-7613096).

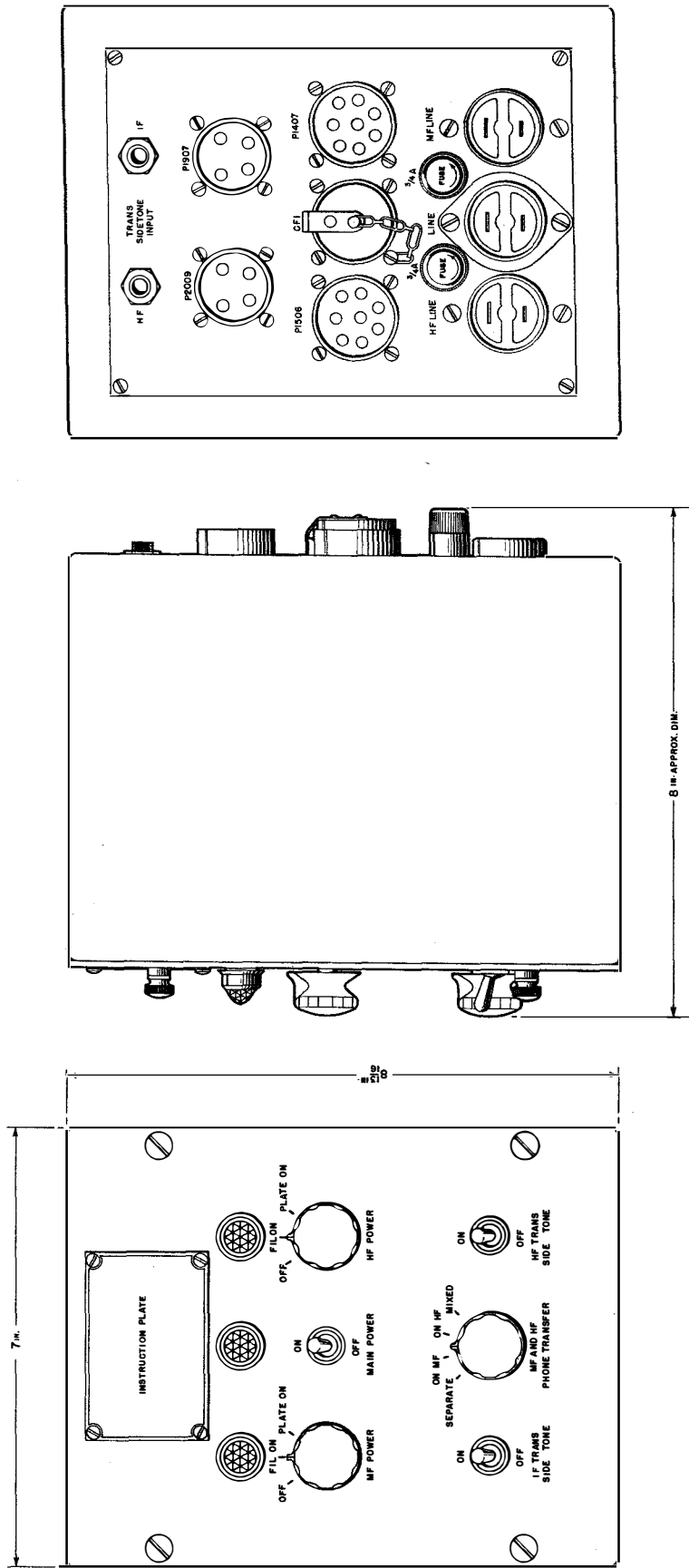
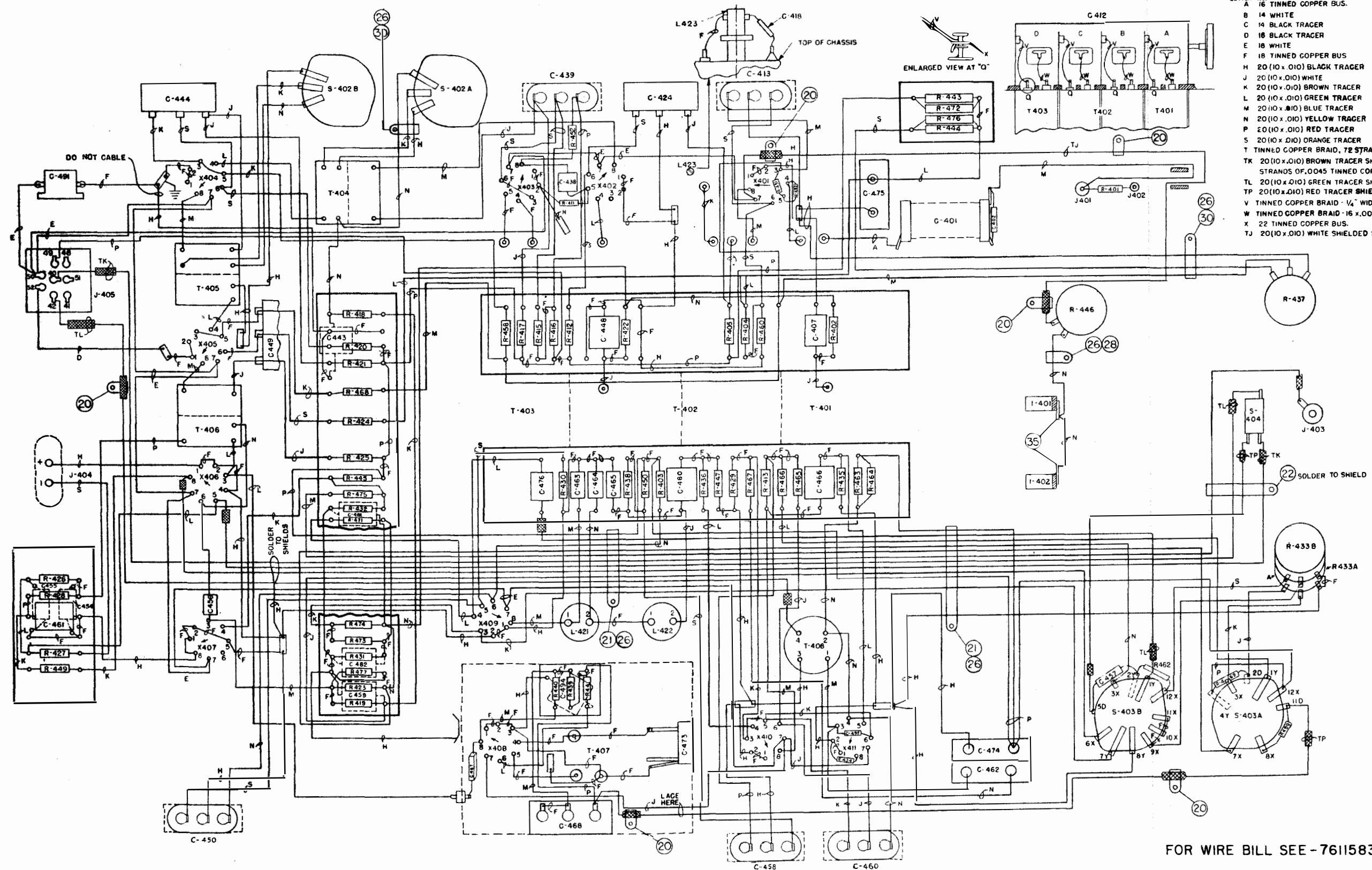

FIG. 55 CONTROL UNIT, TYPE CAY-23278, FOR 115 VOLT, 60 CYCLE, A.C. OPERATION, OUTLINE AND DIMENSIONS (DWG. T-7613097).



LEGEND

LETTER NO	WIRE
A	16 TINNED COPPER BUS.
B	14 WHITE
C	14 BLACK TRACER
D	18 BLACK TRACER
E	18 WHITE
F	18 TINNED COPPER BUS
H	20 (10 x .010) BLACK TRACER
J	20 (10 x .010) WHITE
K	20 (10 x .010) BROWN TRACER
L	20 (10 x .010) GREEN TRACER
M	20 (10 x .010) BLUE TRACER
N	20 (10 x .010) YELLOW TRACER
P	20 (10 x .010) RED TRACER
S	20 (10 x .010) ORANGE TRACER
T	TINNED COPPER BRAID, 72 STRANDS, .0045 TC
TK	20 (10 x .010) BROWN TRACER SHIELDED WITH 72 STRANDS OF .0045 TINNED COPPER
TL	20 (10 x .010) GREEN TRACER SHIELDED SAME AS TK
TP	20 (10 x .010) RED TRACER SHIELDED SAME AS TK
V	TINNED COPPER BRAID - 1/4" WIDE
W	TINNED COPPER BRAID - 16 x .0063
X	22 TINNED COPPER BUS.
TJ	20 (10 x .010) WHITE SHIELDED SAME AS TK

FIG. 56 MEDIUM FREQUENCY RECEIVER, TYPE CAY-46076-A, WIRING DIAGRAM (DWG. T-7611589).

FOR WIRE BILL SEE - 7611583

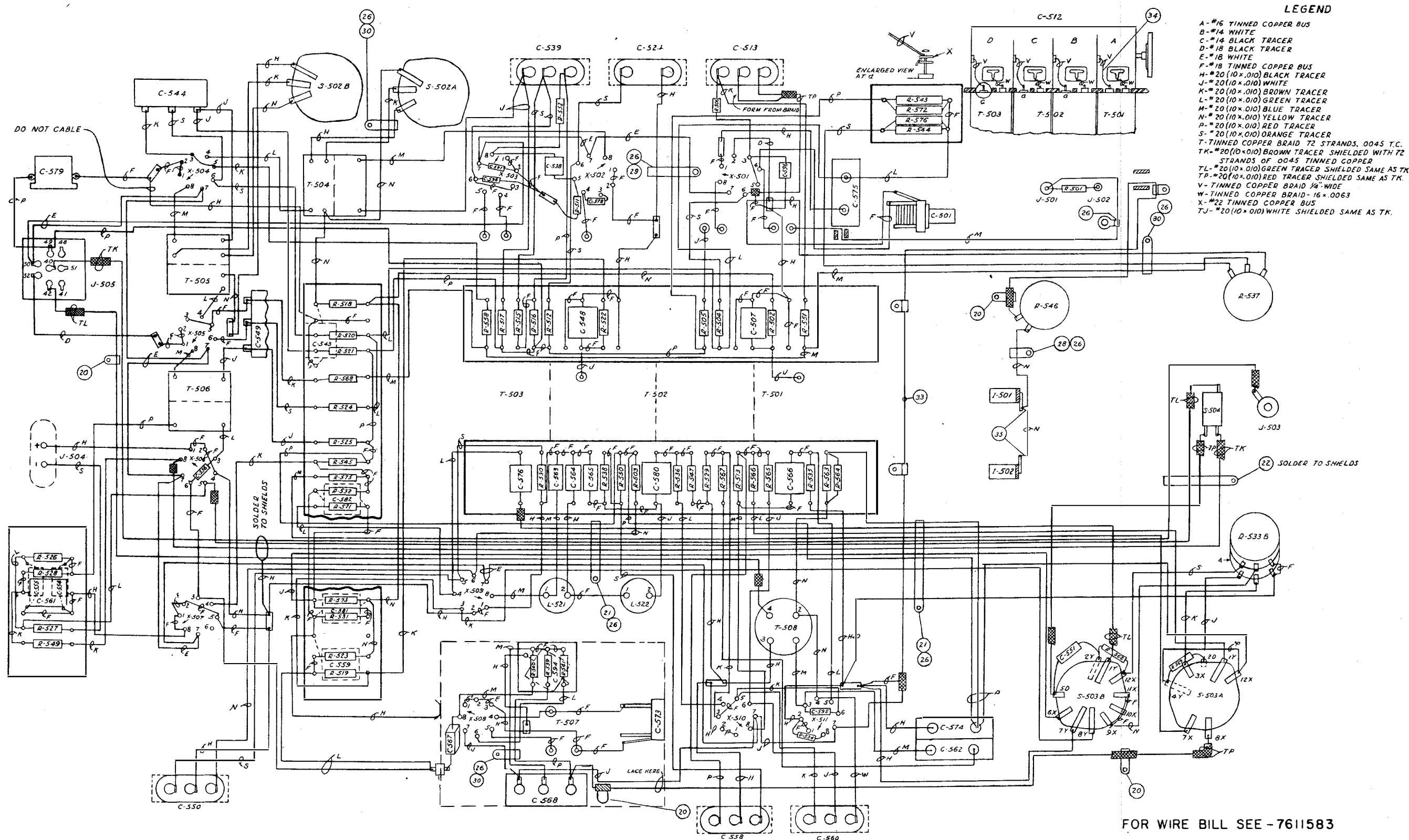

LEGEND

- A-#16 TINNED COPPER BUS
- B-#14 WHITE
- C-#14 BLACK TRACER
- D-#18 BLACK TRACER
- E-#18 WHITE
- F-#18 TINNED COPPER BUS
- H-#20 (10x.010) BLACK TRACER
- J-#20 (10x.010) WHITE
- K-#20 (10x.010) BROWN TRACER
- L-#20 (10x.010) GREEN TRACER
- M-#20 (10x.010) BLUE TRACER
- N-#20 (10x.010) YELLOW TRACER
- P-#20 (10x.010) RED TRACER
- S-#20 (10x.010) ORANGE TRACER
- T-TINNED COPPER BRAID 72 STRANDS, 0045 T.C.
- TK-#20 (10x.010) BROWN TRACER SHIELDED WITH 72 STRANDS OF 0045 TINNED COPPER
- TL-#20 (10x.010) GREEN TRACER SHIELDED SAME AS TK
- TP-#20 (10x.010) RED TRACER SHIELDED SAME AS TK
- V-TINNED COPPER BRAID 1/4" WIDE
- W-TINNED COPPER BRAID-16x.0063
- X-#12 TINNED COPPER BUS
- TJ-#20 (10x.010) WHITE SHIELDED SAME AS TK.

FOR WIRE BILL SEE -7611583

FIG. 57 HIGH FREQUENCY RECEIVER, TYPE CAY-46077-A, WIRING DIAGRAM (DWG. T-7611587).

FIG. 58 DYNAMOTOR ASSEMBLY, TYPE CAY-21387-A, WIRING DIAGRAM (DWG. T-7611585).
11-58

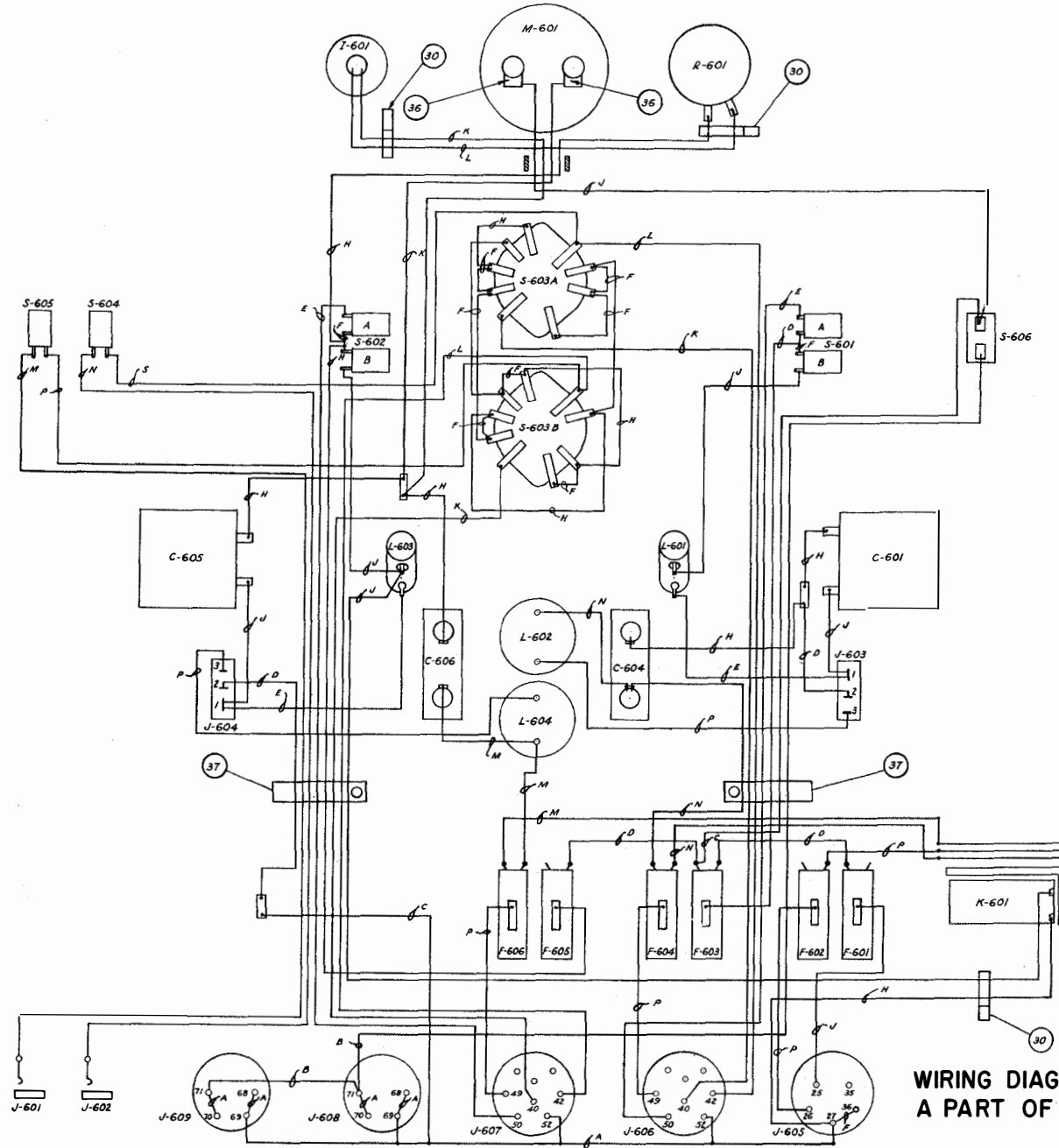

LEGEND

- A-#16 TINNED COPPER BUS
- B-#14 WHITE
- C-#14 BLACK TRACER
- D-#18 BLACK TRACER
- E-#18 WHITE
- F-#18 TINNED COPPER BUS
- H-#20 (10x.010) BLACK TRACER
- J-#20 (10x.010) WHITE TRACER
- K-#20 (10x.010) BROWN TRACER
- L-#20 (10x.010) GREEN TRACER
- M-#20 (10x.010) BLUE TRACER
- N-#20 (10x.010) YELLOW TRACER
- P-#20 (10x.010) RED TRACER
- S-#20 (10x.010) ORANGE TRACER

WIRING DIAGRAM-DYNAMOTOR UNIT-CAY-21387-A
A PART OF RBM-5 RECEIVING EQUIPMENT.

FOR WIRE BILL SEE-7611583

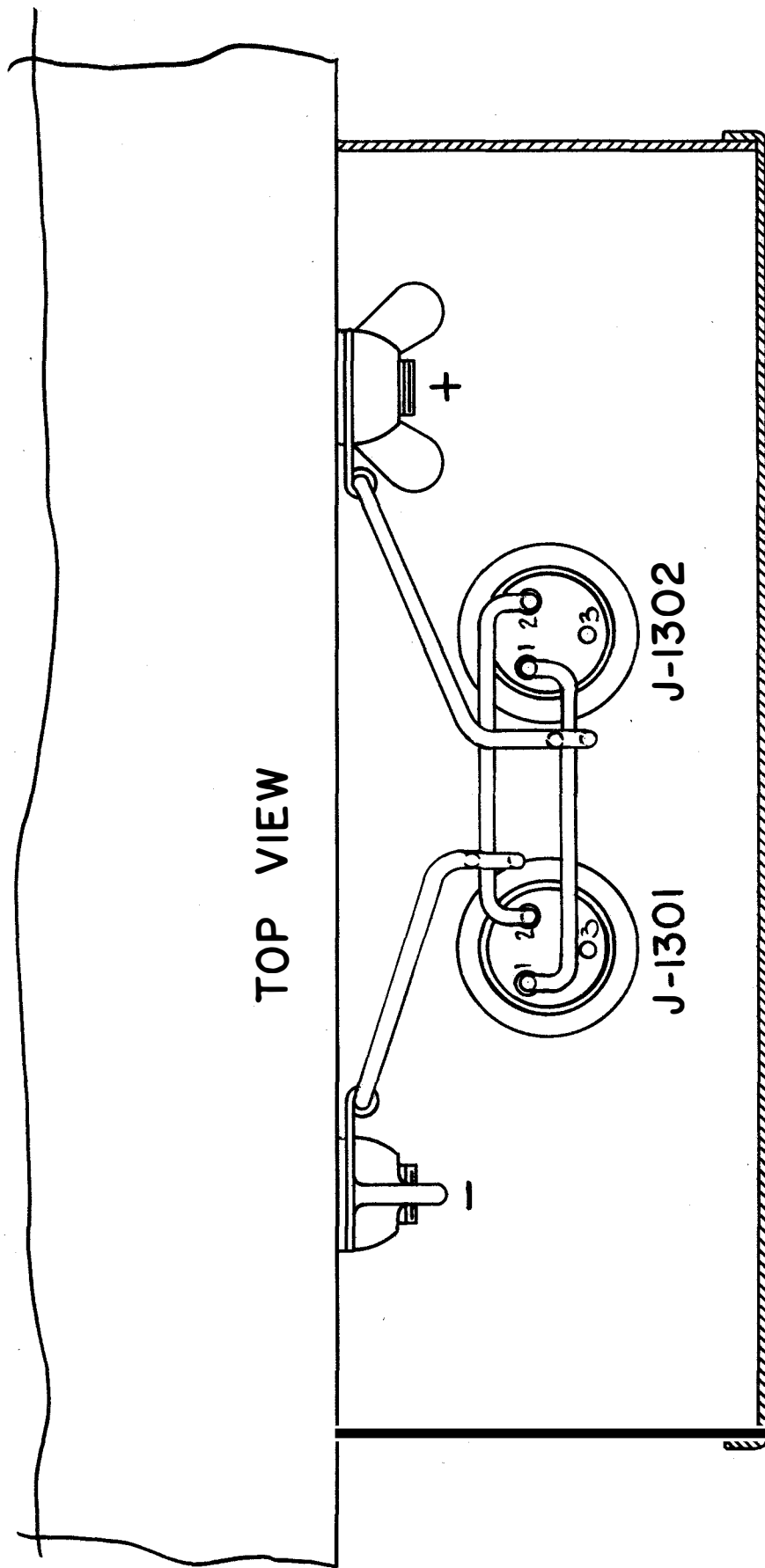
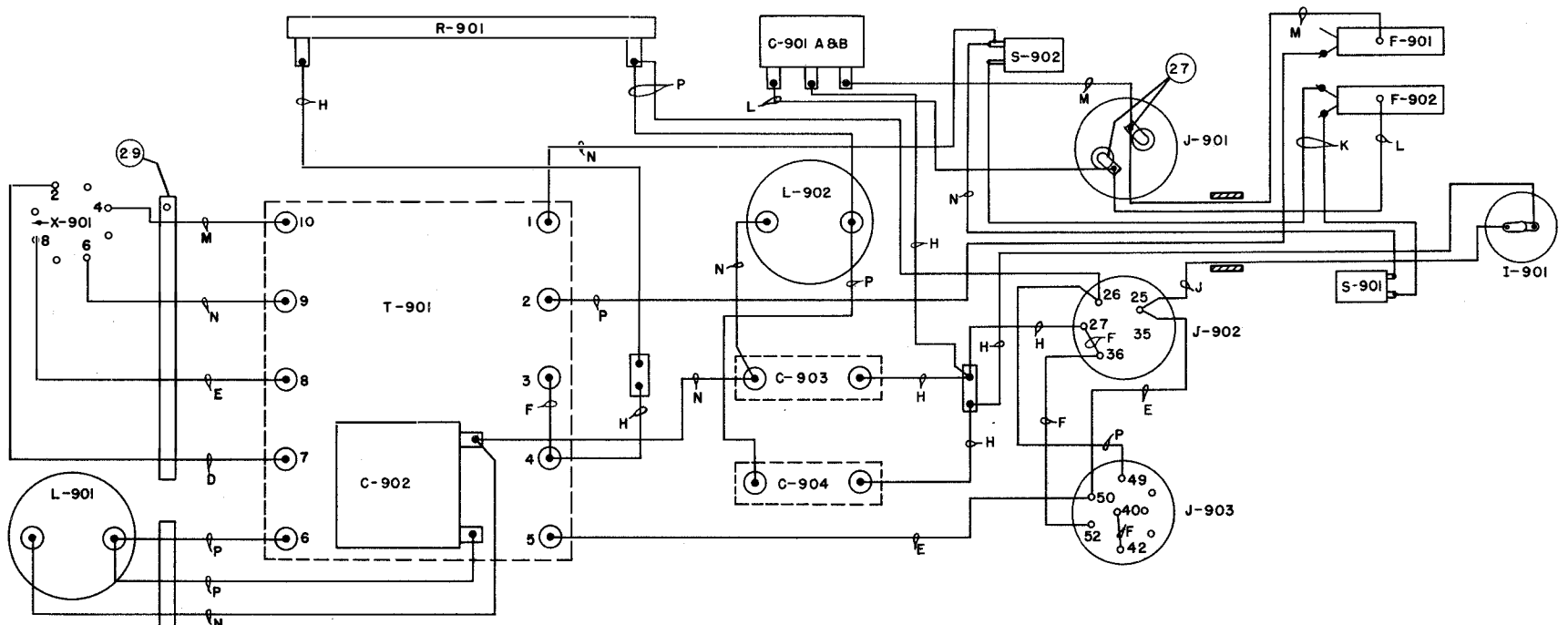

FIG. 59 PORTABLE STORAGE BATTERY, TYPE CES-19017, WIRING DIAGRAM (DWG. M-7408610).

FIG. 60 RECTIFIER POWER UNIT, TYPE CAY-20086, FOR 115 VOLT, 60 CYCLE, A.C. OPERATION.
 WIRING DIAGRAM (DWG. P-7711546).
 11-60



WIRE LEGEND

- D - #18 (16 X .010) BLACK TRACER
- E - #18 (16 X .010) WHITE
- F - #18 TINNED COPPER BUS
- H - #20 (10 X .010) BLACK TRACER
- J - #20 (10 X .010) WHITE
- K - #20 (10 X .010) BROWN TRACER
- L - #20 (10 X .010) GREEN TRACER
- M - #20 (10 X .010) BLUE TRACER
- N - #20 (10 X .010) YELLOW TRACER
- P - #20 (10 X .010) RED TRACER

FOR WIRE BILL SEE-7611583

FIG. 61 CONTROL UNIT, TYPE CAY-23278, FOR 115 VOLT, 60 CYCLE, A.C. OPERATION, WIRING DIAGRAM (DWG. T-7611584).

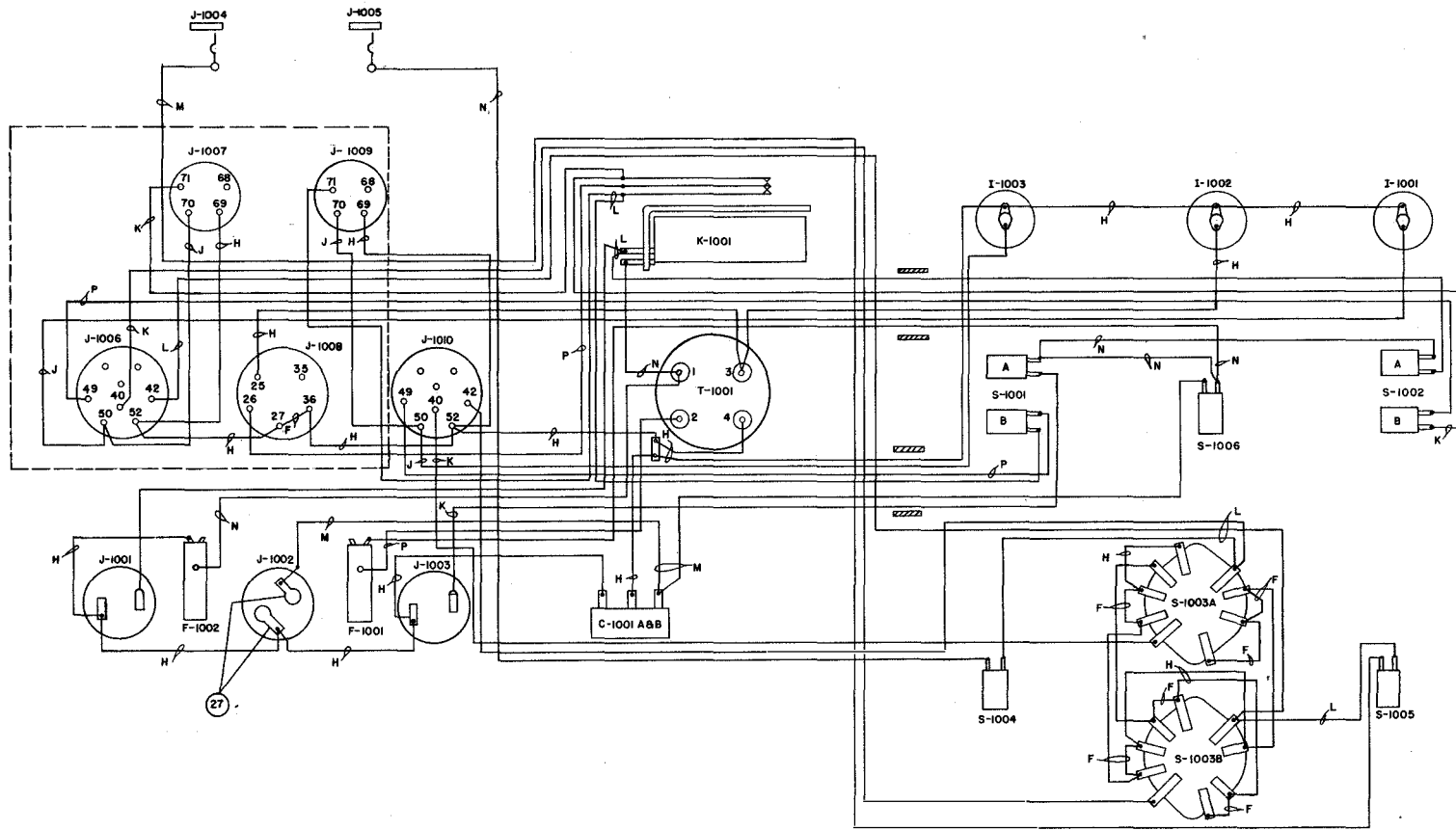

- WIRE LEGEND**
- F- # 18 TINNED COPPER BUS
 - H- # 20(10X.010) BLACK TRACER
 - J- # 20(10X.010) WHITE TRACER
 - K- # 20(10X.010) BROWN TRACER
 - L- # 20(10X.010) GREEN TRACER
 - M- # 20(10X.010) BLUE TRACER
 - N- # 20(10X.010) YELLOW TRACER
 - P- # 20(10X.010) RED TRACER

FOR WIRE BILL SEE -7611583

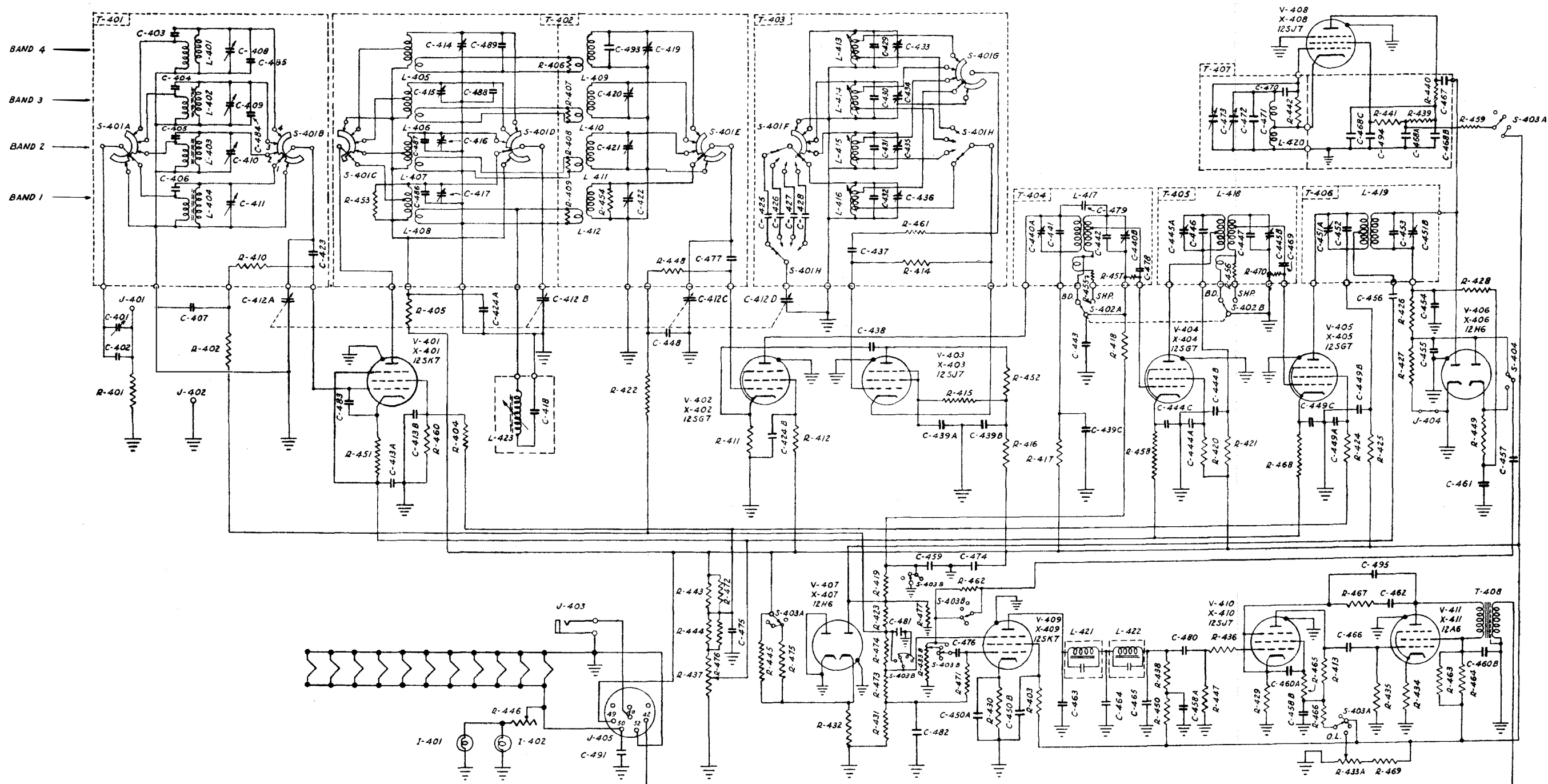

FIG. 62 MEDIUM FREQUENCY RECEIVER, TYPE CAY-46076-A, SCHEMATIC DIAGRAM (DWG. T-7611588).

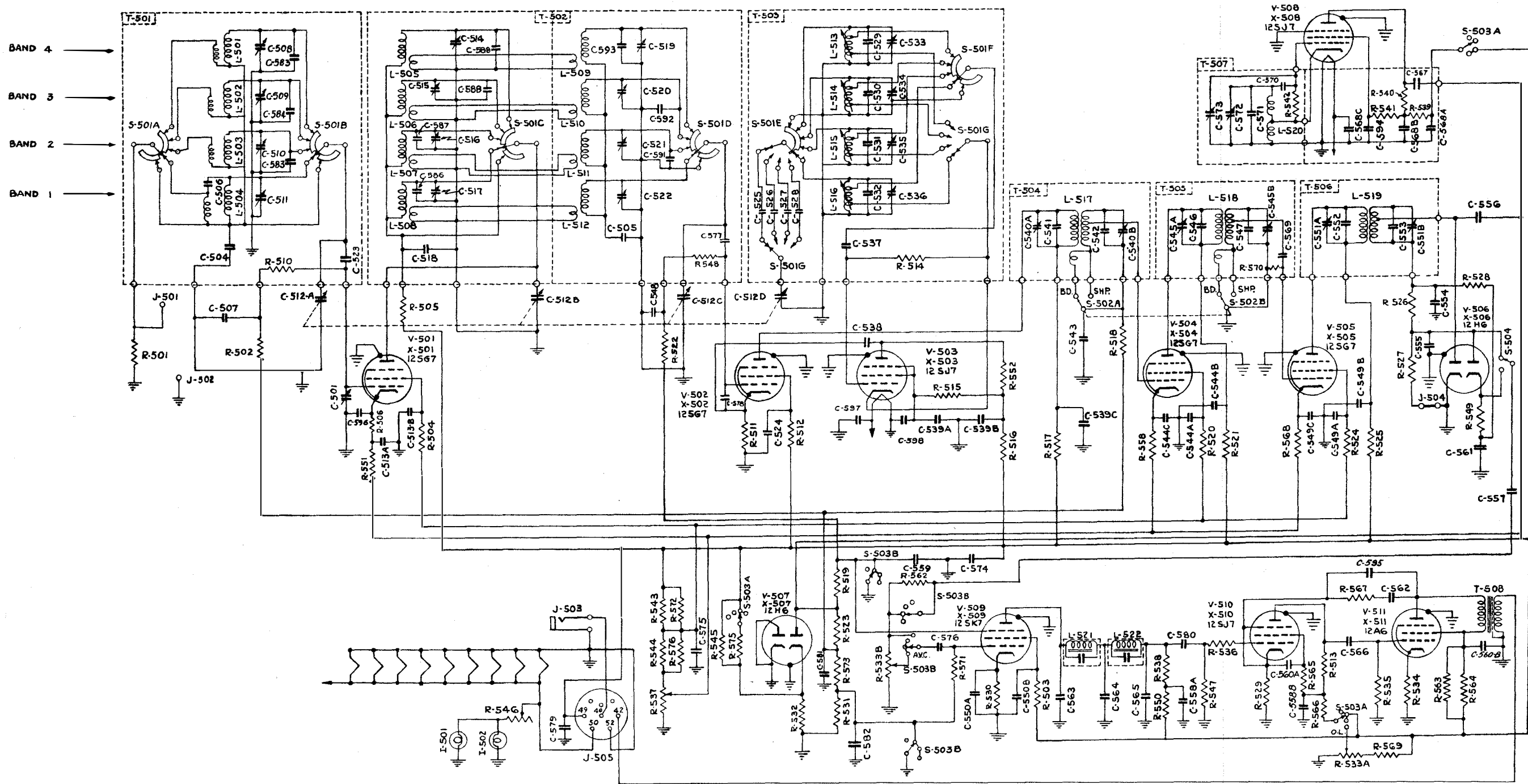
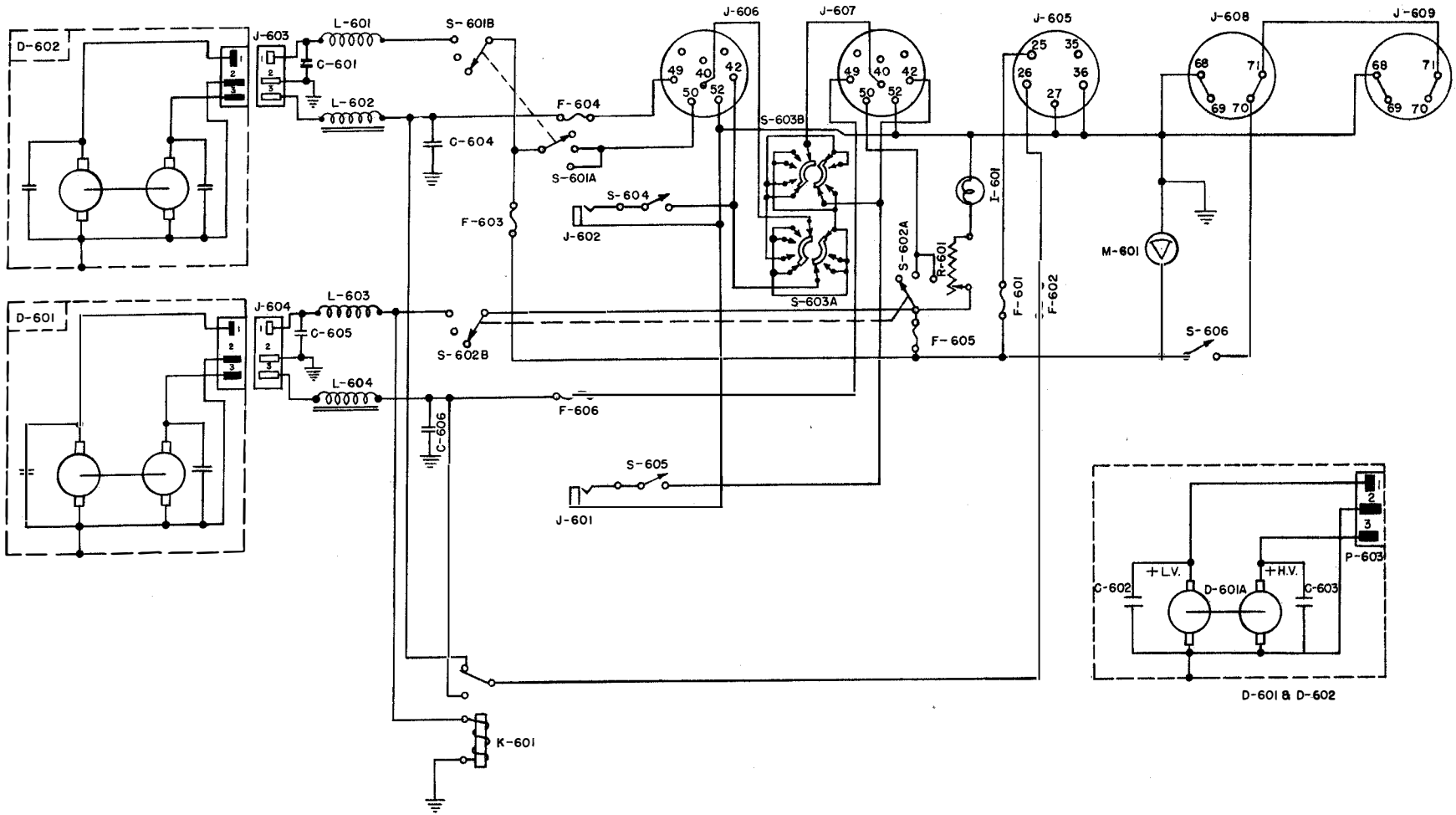
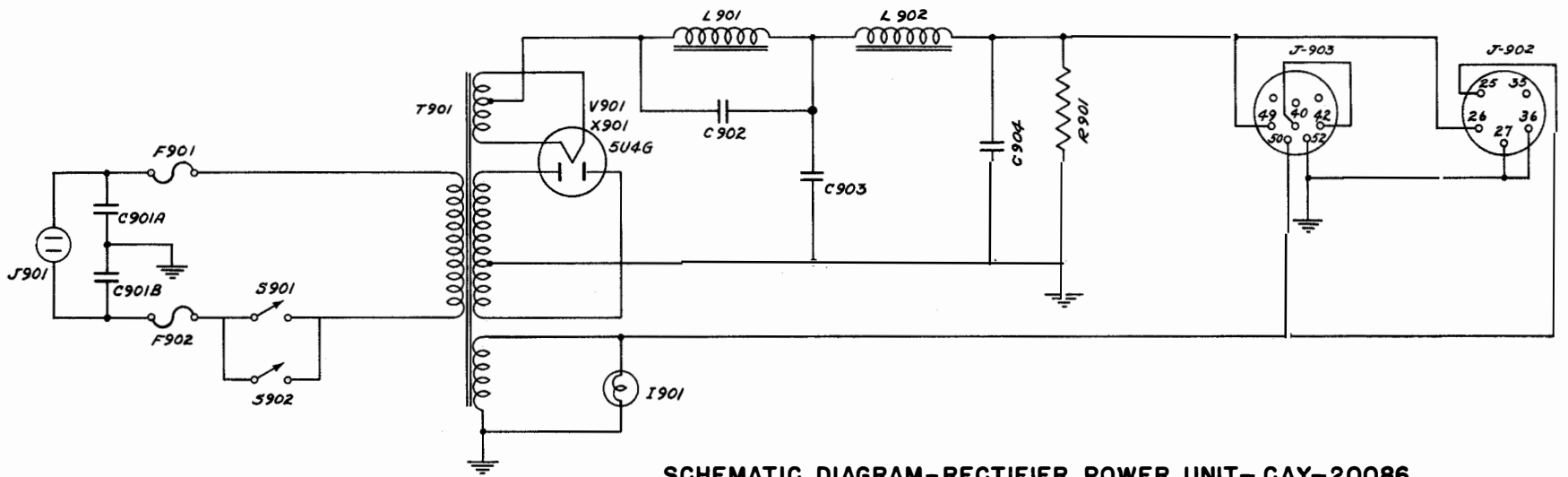

FIG. 63 HIGH FREQUENCY RECEIVER, TYPE CAY-46077-A, SCHEMATIC DIAGRAM (DWG. T-7611586).

FIG. 64 DYNAMOTOR ASSEMBLY, TYPE CAY-21387-A, SCHEMATIC DIAGRAM (DWG. P-7711543).
11-64





SCHEMATIC DIAGRAM-RECTIFIER POWER UNIT-CAY-20086
 A PART OF RBM-5 RECEIVING EQUIPMENT-115/1/60

FIG. 65 RECTIFIER POWER UNIT, TYPE CAY-20086, FOR 115 VOLT, 60 CYCLE, A.C. OPERATION,
 SCHEMATIC DIAGRAM (DWG. P-7711545).

FIG. 66 CONTROL UNIT, TYPE CAY-23278, FOR 115 VOLT, 60 CYCLE, A.C. OPERATION, SCHEMATIC DIAGRAM (DWG. P-7711544).

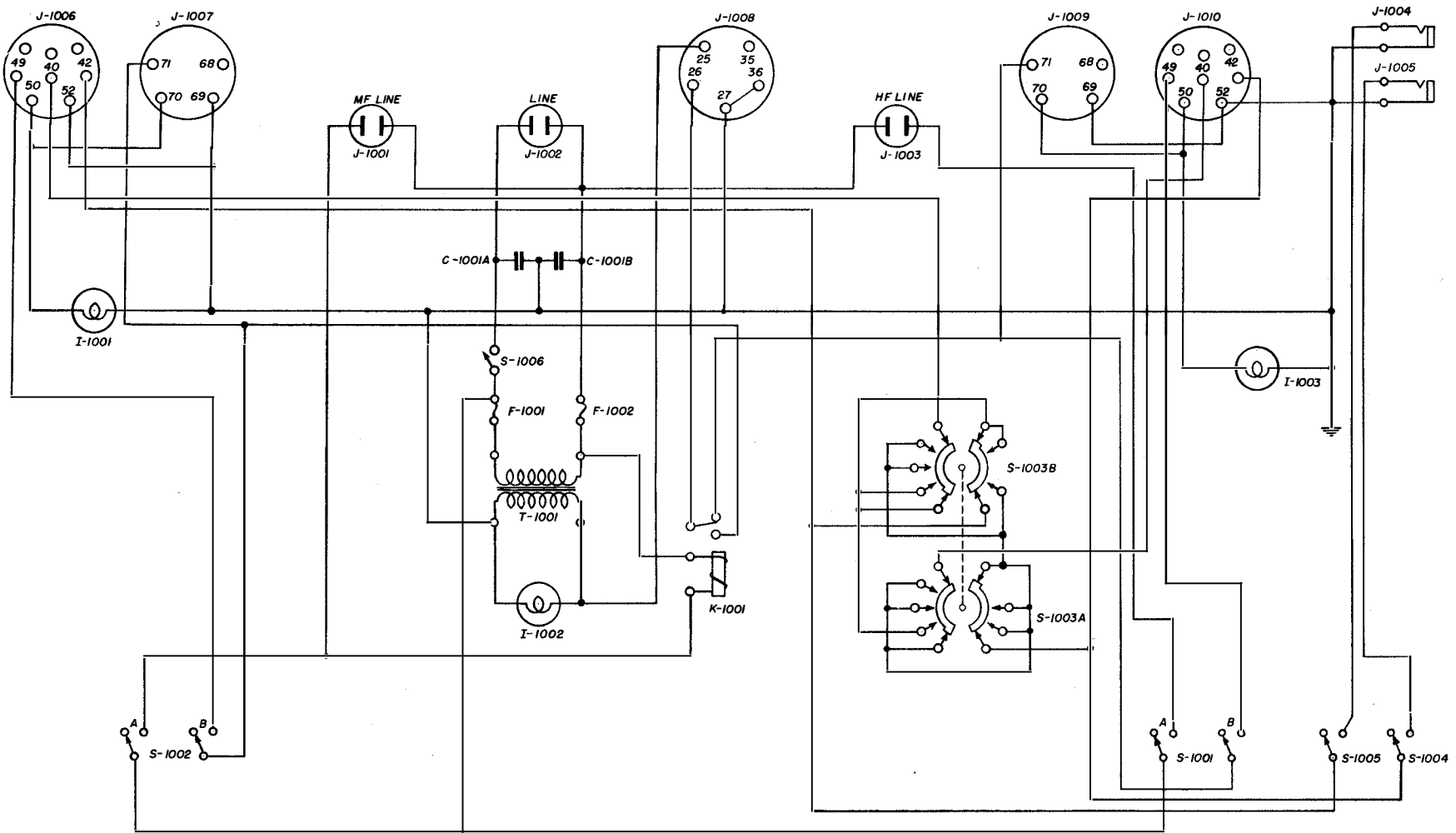

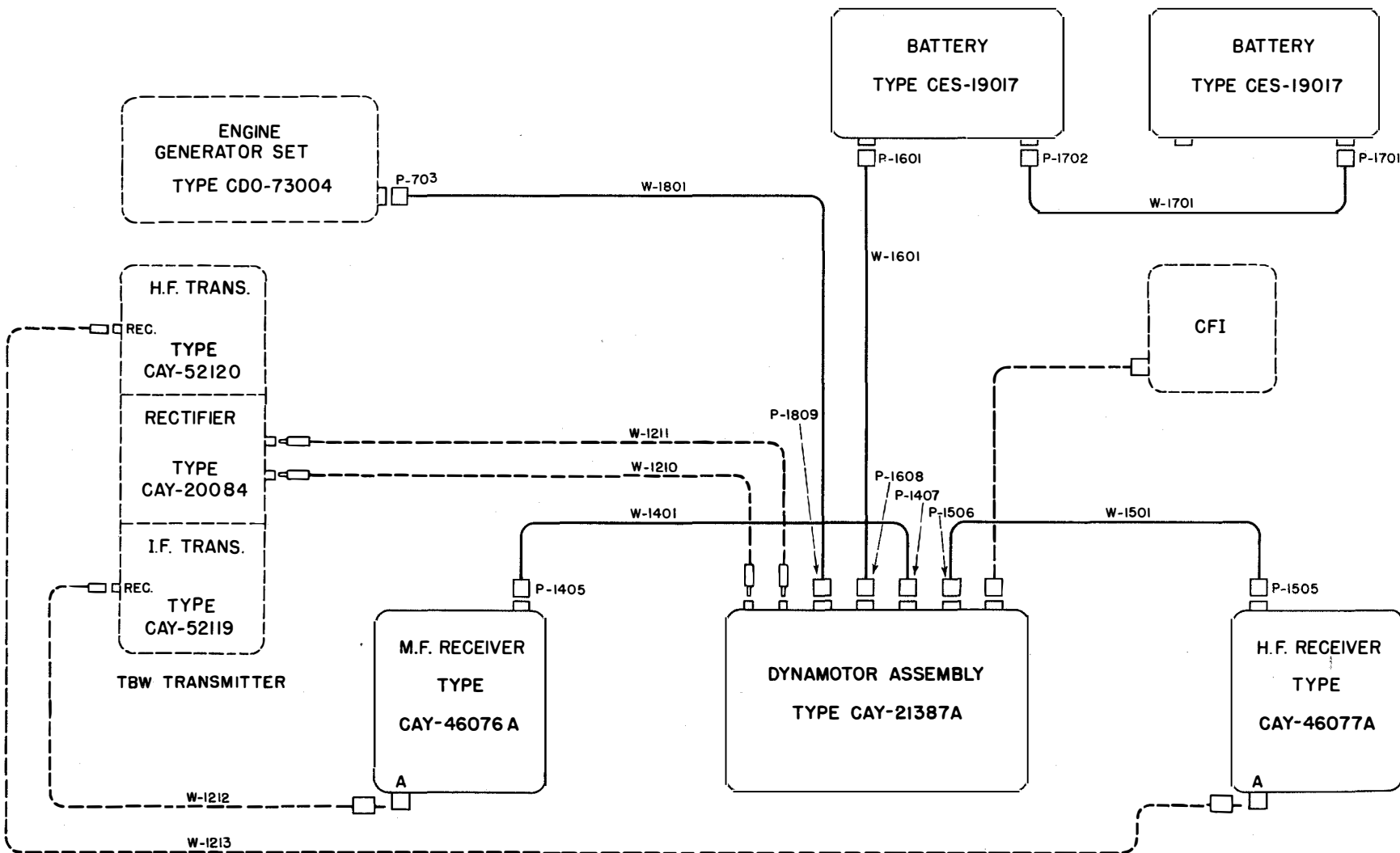

FIG. 68 RADIO RECEIVING EQUIPMENT MODEL RBM-5, INTERCONNECTION DIAGRAM, PORTABLE COMPONENTS USED IN FIELD SERVICE (DWG. P-7713096).

MODEL	POWER UNIT TYPE NUMBER	CONTROL UNIT TYPE NUMBER
RBM	20085 OR 20086	23277 OR 23278
RBM-1	20086	23278
RBM-2	20085 OR 20086	23277 OR 23278
RBM-3	20085 OR 20086	23277 OR 23278
RBM-4	20086	23278
RBM-5	20086	23278

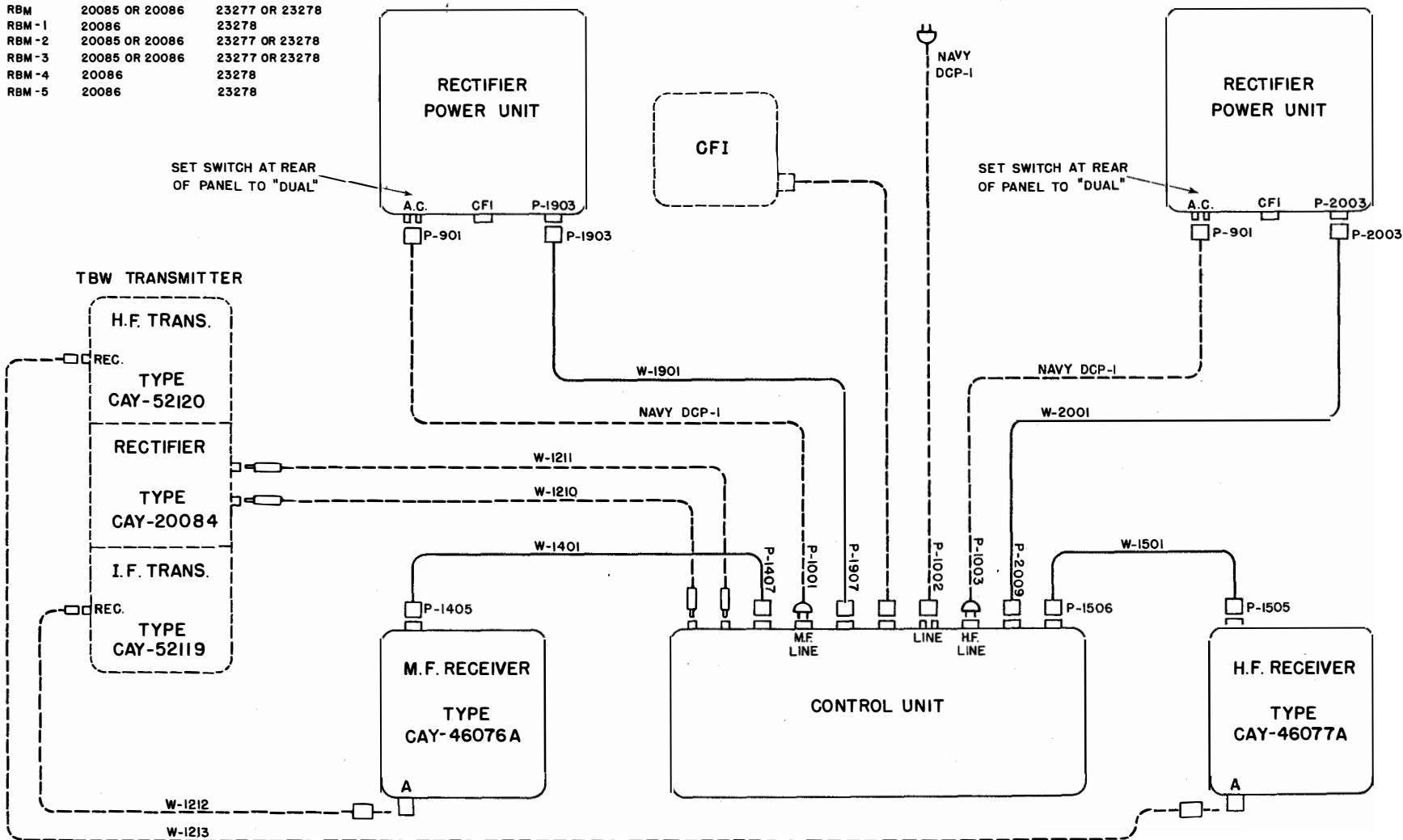
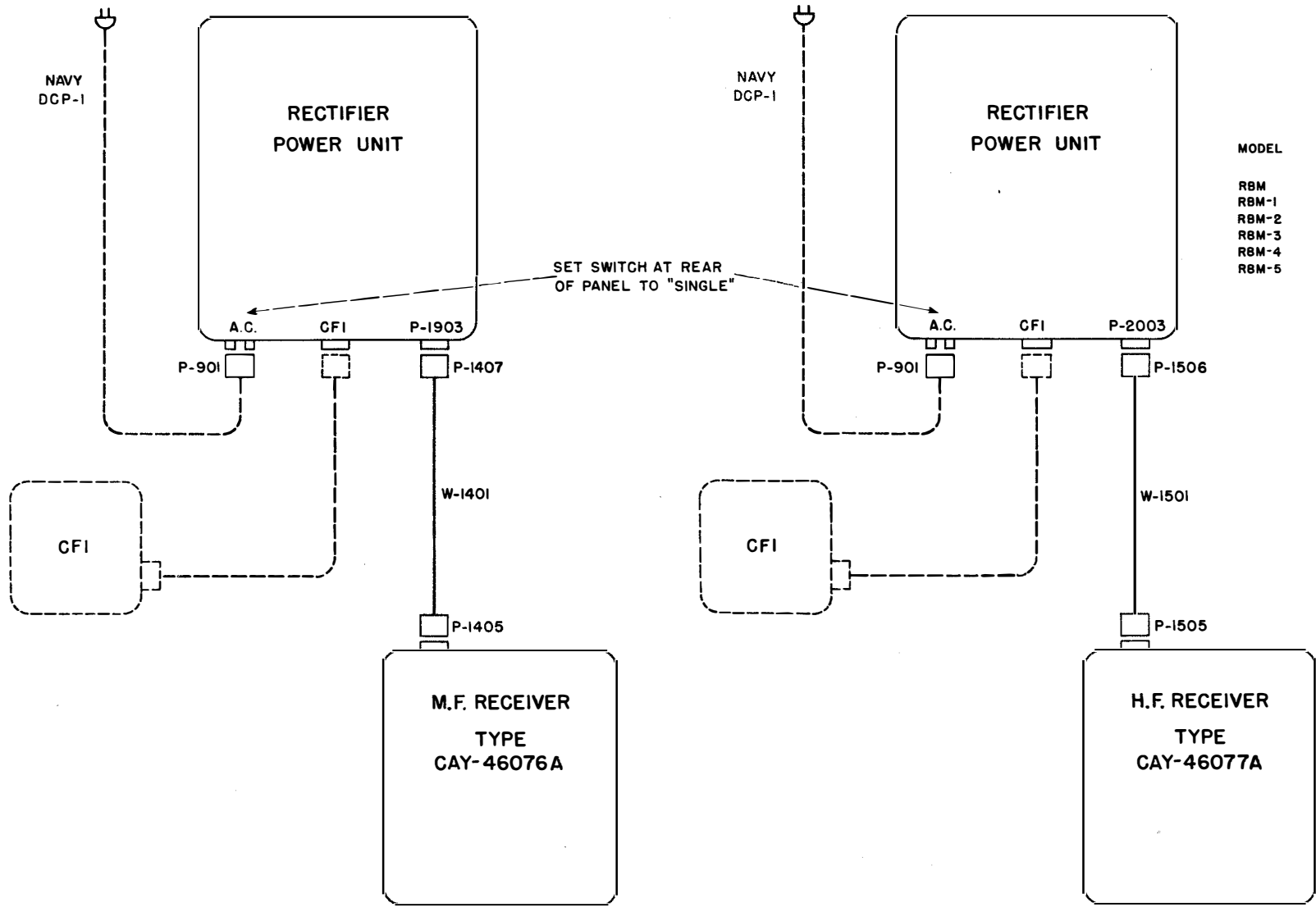

Fig. 69 RADIO RECEIVING EQUIPMENT MODEL RBM-5, INTERCONNECTION DIAGRAM, COMPONENTS USED IN BASE STATION DUAL OPERATION (DWG. P-7713095).



MODEL	POWER UNIT TYPE NUMBER
RBM	20085 OR 20086
RBM-1	20086
RBM-2	20085 OR 20086
RBM-3	20085 OR 20086
RBM-4	20086
RBM-5	20086

FIG. 70 RADIO RECEIVING EQUIPMENT MODEL RBM-5, INTERCONNECTION DIAGRAM, COMPONENTS USED IN BASE STATION SINGLE OPERATION (DWG. P-7713094).
11-70

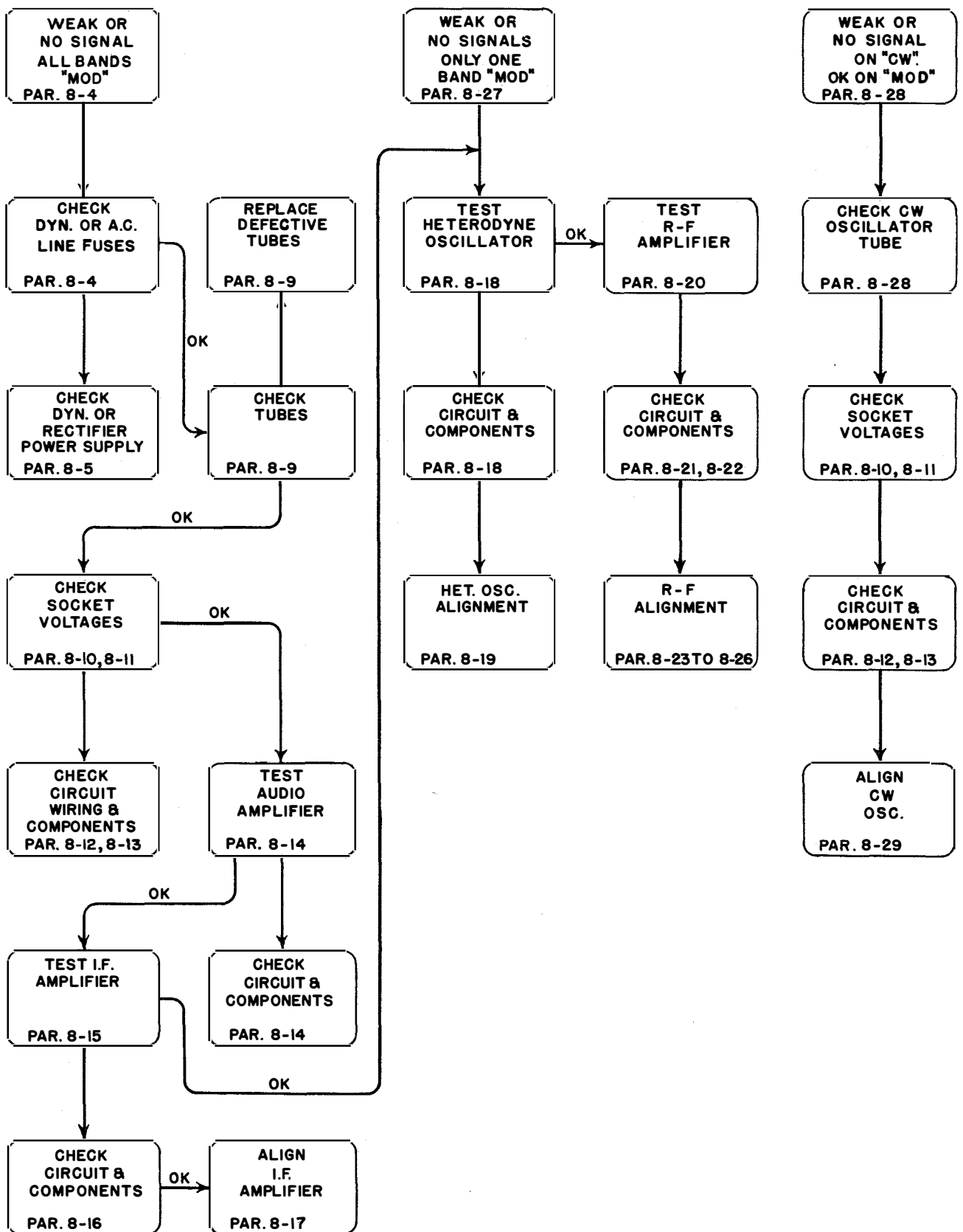
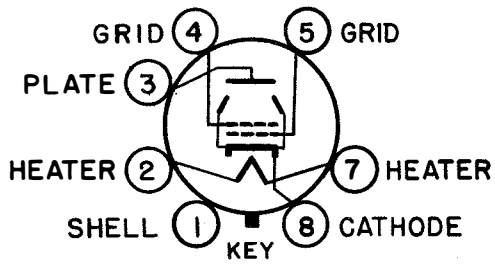
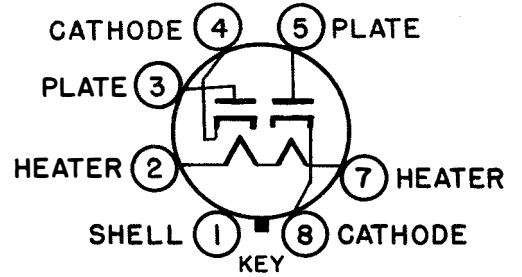

FIG. 73 STAGE-BY-STAGE TROUBLE-SHOOTING DIAGRAM (Dwg. P-7709095).



TYPE 12A6



TYPE 12H6

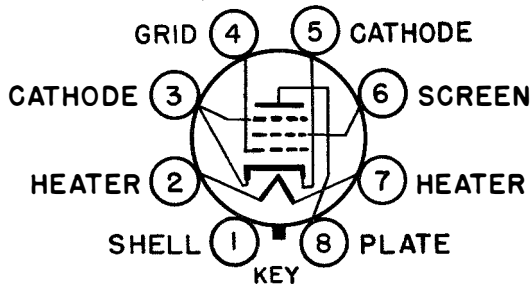

TYPE 12SG7

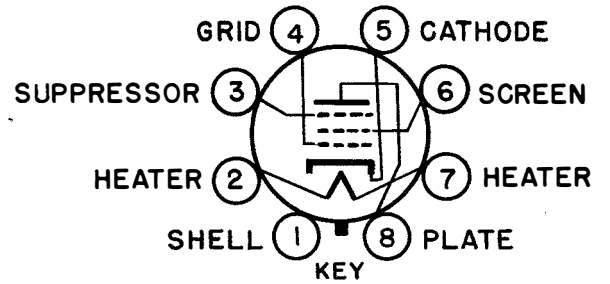

TYPE 12SJ7

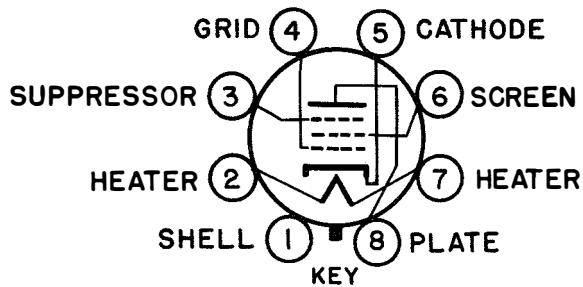

TYPE 12SK7

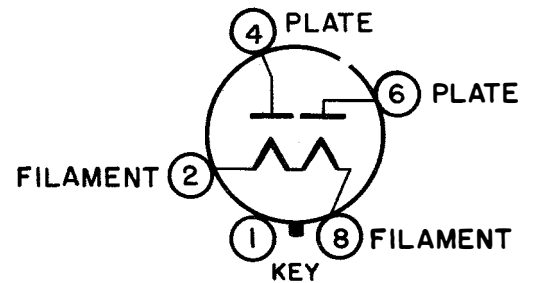

TYPE 5U4G

FIG. 74 TUBE SOCKET DIAGRAMS (DWG. P-7709096).

(11)

Mobile spares only

TABLE II MOBILE SPARE PARTS LIST BY SYMBOL DESIGNATION FOR REAS SEMI-PORTABLE RADIO RECEIVER EQUIPMENT										SPARE PARTS		
BATTERY OR GO. SUPPLY CY. A.C.	SYMBOL DESIG.	FUNCTION	DESCRIPTION	NAVY TYPE NUMBER	NAVY SPEC. OR DRAWING NUMBER	MFR.	MFR. DESIG.	SPECIAL TOL. RATING OR MODIFICATION	CONTRACTOR'S DRAWING AND PART NUMBER	BOX NUMBER	QUANTITY	ALL SYMBOL DESIGNATIONS INVOLVED
	CAPACITORS (CLASS 48)											
X	C-602	FILTER DYN. H.V. BRUSH CAPACITOR	690 MMFD. ±5%, 500 V.D.C. WORKING, MICA	-48149LB5	RE48A148C RE48A154F	2	1468LS §		T-7607845 P2	1	◇	C-602
X	C-603	FILTER DYN. L.V. BRUSH CAPACITOR	0.01 MFD. ±10%, 300 V.D.C. WORKING, MICA	-48848-B10	RE48AA143F RE48A154F	3	1467LS §		T-7607845 P3	1	◇	C-603
DYNAMOTORS (CLASS 21)												
X	D-601	DYNAMOTOR	DYNAMOTOR ASSEMBLY OF SHOCKMOUNT, CAPACITORS & PLUG			1			P-7708216 G1	1	1	D-601, D-602
X	D-601A	DYNAMOTOR	INPUT, 12 V.D.C., 3 AMPS., OUTPUT 235 V., .075 AMP.	-21772		1			P-7708217 G1	1	◇	D-601A
X	D-602	DYNAMOTOR	SAME AS D-601							1		
MISCELLANEOUS (CLASS 10)												
X	E-601	DYNAMOTOR BRUSH	FOR D-601 OR D-602			1			T-7607845 P12	1	4 SET	E-601
FUSES (CLASS 2B)												
X	F-601A	C.F.I. LOW VOLTAGE FUSE	5 AMPS., 25 VOLTS, NON-RENEWABLE			4	3AG #1080 3AG5		T-7607845 P13	1	2	F-601A
X	F-602A	C.F.I. HIGH VOLTAGE FUSE	0.25 AMP., 250 VOLTS, NON-RENEWABLE			4	3AG #1045 3AG-1/4		T-7607845 P15	1	6	F-602A, F-604A, F-606A
X	F-603A	H.F. RECEIVER LOW VOLTAGE FUSE	15 AMPS., 25 VOLTS, NON-RENEWABLE			4	3AG #1082 3AG15		T-7607845 P17	1	4	F-603A, F-605A
X	F-604A	H.F. RECEIVER HIGH VOLTAGE FUSE	SAME AS F-602A							1		
X	F-605A	M.F. RECEIVER LOW VOLTAGE FUSE	SAME AS F-603A							1		
X	F-606A	M.F. RECEIVER HIGH VOLTAGE FUSE	SAME AS F-602A							1		
MISCELLANEOUS (CLASS 10)												
X	I-401	M.F. RECEIVER DIAL LAMP	12 TO 16 VOLTS, T-3-1/4 BULB, 0.2 AMP., PANEL LAMP, MINIATURE BAYONET BASE			1			T-7608014 P235	1	1	I-401, I-402, I-501, I-502, I-601

§ WHEN ORDERING, INCLUDE CAPACITY AND VOLTAGE.
 ◇ SUPPLIED IN SPARE SUB ASSEMBLIES D-601 OR D-602.

cuts

Max Munch 6-8-44

TABLE II (CONTINUED)											
MOBILE SPARE PARTS LIST BY SYMBOL DESIGNATION FOR RBM-5 SEMI-PORTABLE RADIO RECEIVER EQUIPMENT											
BATTERY OR 60 CY. A.C. SUPPLY	SYMBOL DESIG.	FUNCTION	DESCRIPTION	NAVY TYPE NUMBER	NAVY SPEC. OR DRAWING NUMBER	MFR.	MFR. DESIG.	SPECIAL TOL. RATING OR MODIFICATION	CONTRACTOR'S DRAWING AND PART NUMBER	SPARE PARTS	
										BOX NUMBER	QUANTITY
MISCELLANEOUS (CLASS 10) CONTINUED											
X	I-402	M.F. RECEIVER DIAL LAMP	SAME AS I-401							1	
X	I-501	H.F. RECEIVER DIAL LAMP	SAME AS I-401							1	
X	I-502	H.F. RECEIVER DIAL LAMP	SAME AS I-401							1	
X	I-601	PANEL LAMP DYNAMOTOR	SAME AS I-401							1	
PLUGS (CLASS 49)											
X	P-603	DYNAMOTOR PLUG	3 CIRCUIT, MALE	-49178			P-303-AB		M-7408053 P1	1	◇ P-603
VACUUM TUBES (CLASS 38)											
X	V-401	R.F. AMPLIFIER VACUUM TUBE	TRIPLE GRID SUPER CONTROL AMPLIFIER. BULB: METAL SHELL, MT-8. BASE: SMALL WAFER OCTAL 8 PIN. HEATER RATING: 12.6 A.C. OR D.C. VOLTS, 0.15 AMP.	-12SK7	JAN 1	6	12SK7		T-7608018 P617	1	1 ✓ V-401, V-409, V-509
X	V-402	1ST DETECTOR VACUUM TUBE	HIGH FREQUENCY AMPLIFIER, SINGLE ENDED METAL TYPE WITH SEMI REMOTE CUT-OFF. BULB: METAL SHELL MT-8. BASE: SMALL WAFER OCTAL 8 PIN. HEATER RATING: 12.6 A.C. OR D.C. VOLTS, 0.15 AMP.	-12SG7	JAN 1	6	12SG7		T-7608018 P618	1	2 ✓ V-402, V-408, V-409, V-501, V-502, V-504, V-505
X	V-403	H.F. OSCILLATOR VACUUM TUBE	TRIPLE GRID DETECTOR AMPLIFIER. BULB: METAL SHELL, MT-8. BASE: SMALL WAFER OCTAL, 8 PIN. HEATER RATING: 12.6 A.C. OR D.C. VOLTS, 0.15 AMP.	-12SJ7	JAN 1	6	12SJ7		T-7608018 P619	1	2 ✓ V-403, V-408, V-410, V-503, V-508, V-510
X	V-404	1ST I.F. AMPLIFIER VACUUM TUBE	SAME AS V-402							1	
X	V-405	2ND I.F. AMPLIFIER VACUUM TUBE	SAME AS V-402							1	
X	V-406	2ND DETECTOR AND NOISE PEAK LIMITER VACUUM TUBE	DUPLEX DIODE. BULB: METAL SHELL MT-8. BASE: SMALL WAFER OCTAL, 7 PIN. HEATER RATING: 12.6 A.C. OR D.C. VOLTS, 0.15 AMP.	-12H6	JAN 1	6	12H6		T-7608018 P622	1	1 ✓ V-406, V-407, V-506, V-507
X	V-407	A.V.C. DIODE VACUUM TUBE	SAME AS V-406	-12H6						1	
X	V-408	C.W. OSCILLATOR VACUUM TUBE	SAME AS V-403	-12SJ7						1	

◇ SUPPLIED IN SPARE SUB ASSEMBLIES D-601 OR D-602.

TABLE II (CONTINUED)

MOBILE SPARE PARTS LIST BY SYMBOL DESIGNATION FOR REM-5 SEMI-PORTABLE RADIO RECEIVER EQUIPMENT

SPARE PARTS

BATTERY OR 60. CY. A.C. SUPPLY	SYMBOL DESIG.	FUNCTION	DESCRIPTION	NAVY TYPE NUMBER	NAVY SPEC. OR DRAWING NUMBER	MFR.	MFR. DESIG.	SPECIAL TOL. RATING OR MODIFICATION	CONTRACTOR'S DRAWING AND PART NUMBER	SPARE PARTS	
										BOX NUMBER	QUANTITY
VACUUM TUBES (CLASS 38) CONTINUED											
X	V-409	1ST A.F. AMPLIFIER VACUUM TUBE	SAME AS V-401	-12SK7						1	
X	V-410	2ND A.F. AMPLIFIER VACUUM TUBE	SAME AS V-403	-12SJ7						1	
X	V-411	3RD A.F. AMPLIFIER VACUUM TUBE	BEAM POWER AMPLIFIER PENTODE. BULB: METAL SHEATH, MT-8. BASE: SMALL WAFER OCTAL, 7 PIN. HEATER RATING: 12.6 A.C. OR D.C. VOLTS, 0.15 AMP.	-12A6	JAN 1	6	12A6		T-7608018 P627	1	1 V-411, V-511
X	V-501	R.F. AMPLIFIER VACUUM TUBE	SAME AS V-402	-12SG7						1	
X	V-502	1ST DETECTOR VACUUM TUBE	SAME AS V-402	-12SG7						1	
X	V-503	H.F. OSCILLATOR VACUUM TUBE	SAME AS V-403	-12SJ7						1	
X	V-504	1ST I.F. AMPLIFIER VACUUM TUBE	SAME AS V-402	-12SG7						1	
X	V-505	2ND I.F. AMPLIFIER VACUUM TUBE	SAME AS V-402	-12SG7						1	
X	V-506	2ND DETECTOR AND NOISE PEAK LIMITER VACUUM TUBE	SAME AS V-406	-12H6						1	
X	V-507	A.V.C. DIODE VACUUM TUBE	SAME AS V-406	-12H6						1	
X	V-508	C.W. OSCILLATOR VACUUM TUBE	SAME AS V-403	-12SJ7						1	
X	V-509	1ST A.F. AMPLIFIER VACUUM TUBE	SAME AS V-401	-12SK7						1	
X	V-510	2ND A.F. AMPLIFIER VACUUM TUBE	SAME AS V-403	-12SJ7						1	
X	V-511	3RD A.F. AMPLIFIER VACUUM TUBE	SAME AS V-411	-12A6						1	

SHEET 3

P-7713091

SHEETS 4

**TABLE
INDEX TO MANUFACTURERS**

CODE NUMBER	MFR. PREFIX	NAME	ADDRESS
1	CAY	WESTINGHOUSE ELECTRIC & MFG. CO.	2519 WILKENS AVE. BALTIMORE, MD.
2	CAW	AEROVOX CORP.	742 BELLEVILLE AVE. NEW BEDFORD, MASS.
	CMR	MICAMOLD PRODUCTS CORP.	1087 FLUSHING AVE. BROOKLYN, N. Y.
	CAN	SANGAMO ELECTRIC CO.	SPRINGFIELD, ILL.
3	CAW	AEROVOX CORP.	742 BELLEVILLE AVE. NEW BEDFORD, MASS.
	CMR	MICAMOLD PRODUCTS CORP.	1087 FLUSHING AVE. BROOKLYN, N. Y.
4	CLF	LITTELFUSE LABORATORIES, INC.	4765 RAVENSWOOD AVE. CHICAGO, ILL.
	CFA	BUSSMAN MANUFACTURING CO.	ST. LOUIS, MO.
5	CJC	HOWARD B. JONES	2300 WABANSIA AVE. CHICAGO, ILL.
6	CRC	R.C.A. MANUFACTURING CO.	HARRISON, N. J.