

★
NAVSHIPS—91944

INSTRUCTION BOOK
for
RADIO
RECEIVING EQUIPMENT
NAVY MODEL RBS-3

Contractor:

Z & W MACHINE PRODUCTS, INC.
Cleveland, Ohio

—●—
Manufacturer:

THE SEALTRON CO.
Cincinnati 15, Ohio

BUREAU OF SHIPS

NAVY DEPARTMENT

★
Contract: NObsr 43286

Approved by BuShips: 10

LIST OF EFFECTIVE PAGES

PAGE NUMBERS	CHANGES IN EFFECT	PAGE NUMBERS	CHANGES IN EFFECT
Title page	Original	4-0 to 4-5	Original
A to C	Original	5-0 to 5-2	Original
I to V	Original	6-1 to 6-5	Original
1-0 to 1-9	Original	7-0 to 7-38	Original
2-0 to 2-12	Original	8-1 to 8-35	Original
3-1 to 3-7	Original	i-1 to i-5	Original



DEPARTMENT OF THE NAVY
BUREAU OF SHIPS
WASHINGTON 25, D. C.

IN REPLY REFER TO
Code 993-100
16 July 1953

From: Chief, Bureau of Ships
To: All Activities Concerned with the
Installation, Operation and Main-
tenance of the Subject Equipment

Subj: Instruction Book for Radio Re-
ceiving Equipment Navy Model RBS-3
NAVSHIPS 91944

1. This is the instruction book for the subject equipment and is in effect upon receipt.
2. When superseded by a later edition, this publication shall be destroyed.
3. Extracts from this publication may be made to facilitate the preparation of other Department of Defense Publications.
4. All Navy requests for NAVSHIPS Electronics publications should be directed to the nearest District Publications and Printing Office. When changes or revised books are distributed, notice will be included in the Bureau of Ships Journal and in the Index of Bureau of Ships General and Electronics Publications, NAVSHIPS 250-020.

H. N. WALLIN
Chief of Bureau

TABLE OF CONTENTS

SECTION 1—GENERAL DESCRIPTION		<i>Paragraph</i>	<i>Page</i>
<i>Paragraph</i>			
1.	Quick Reference Data		1—1
	<i>a.</i> General		1—1
	<i>b.</i> Frequency Range		1—1
	<i>c.</i> Power Requirements		1—1
	<i>d.</i> Antenna Requirements		1—1
2.	Equipment Supplied With Navy Model RBS-3		1—2
3.	Export Packing of RBS-3		1—3
4.	Equipment Required But Not Supplied....		1—3
5.	Marking of Spare Parts		1—3
6.	Physical Description of Equipment.....		1—3
	<i>a.</i> Radio Receiver		1—5
	<i>b.</i> Rectifier Power Amplifier Unit		1—5
7.	Electrical Description of Equipment		1—8
	<i>a.</i> Radio Receiver		1—8
	<i>b.</i> Rectifier Power Amplifier		1—8
8.	Summary of Performance		1—8
	<i>a.</i> Sensitivity		1—8
	<i>b.</i> Selectivity of 100X		1—8
	<i>c.</i> Image Rejection at 20 Megacycles		1—8
	<i>d.</i> I.F. Rejection at 2 Megacycles		1—8
	<i>e.</i> Audio Frequency Response		1—8
	<i>f.</i> Oscillator Radiation		1—8
	<i>g.</i> Power Output, M.C.W.		1—9
	<i>b.</i> Dial Calibration		1—9
	<i>i.</i> A. G. C. Characteristic		1—9
	<i>j.</i> Noise Limiter		1—9
 SECTION 2—THEORY OF OPERATION			
1.	Introduction		2—0
2.	The Path of the Signal		2—1
3.	Circuit Analysis of the Radio Receiver....		2—3
	<i>a.</i> The Radio Frequency Circuits		2—3
	(1) General		2—3
	(2) The Radio Frequency Amplifier..		2—3
	(3) The Converter		2—4
	(4) The Heterodyne Oscillator		2—7
	<i>b.</i> The Intermediate Frequency Circuits....		2—7
	<i>c.</i> The Second Detector and Noise Limiter Circuits		2—8
	<i>d.</i> The Beat Frequency Oscillator Circuit		2—9
	<i>e.</i> The Automatic Gain Control Circuit....		2—9
	<i>f.</i> The First and Second Audio Amplifier Circuits		2—9
	<i>g.</i> The Audio Output Circuit		2—9
4.	Circuit Analysis of Rectifier Power Amplifier		2—10
 SECTION 3—INSTALLATION			
1.	Unpacking the Equipment		3—1
2.	Locating the Equipment		3—1
3.	Mounting the RBS-3 Equipment		3—1
4.	Cabling Connections for RBS-3		4—0
	<i>a.</i> Radio Receiver to Rectifier Power Amplifier Unit Connections		4—0
	<i>b.</i> Antenna Connections		4—0
	<i>c.</i> Loudspeaker Cable Connection		4—0
	<i>d.</i> A.C. Input Power Cable Connection....		4—0
 SECTION 4—OPERATION			
1.	Panel Markings and Controls		4—0
	<i>a.</i> General		4—0
	<i>b.</i> Panel Markings and Controls on the Rectifier Power Amplifier Unit....		4—0
	(1) "POWER, ON OFF"		4—0
	(2) "HEADPHONE LEVEL CONTROL"		4—0
	(3) "F-901 FUSE" and "F-902 FUSE"		4—0
	(4) "PHONES"		4—1
	<i>c.</i> Panel Markings and Controls on the Radio Receiver		4—1
	(1) "SELECTIVITY"		4—1
	(2) "GAIN"		4—1
	(3) "NOISE LIMITER"		4—1
	(4) "OUTPUT LEVEL"		4—1
	(5) "RECEPTION"		4—1
	(6) "ANT COMP" (Antenna Compensator)		4—2
	(7) "BEAT NOTE"		4—2
	(8) "FREQ BAND" (Frequency Band)		4—2
	(9) "LOCK" (Lock for tuning control)		4—2
	(10) "OFF LIGHT"		4—2
	(11) "ANT" and "GND" (Antenna and Ground Posts)		4—2
	(12) "TUNING"		4—2
	<i>(a)</i> Description		4—2
	<i>(b)</i> Reading the Dial and Recording Dial Settings		4—3
2.	Preliminary Adjustments		4—3
	<i>a.</i> Purpose		4—3
	<i>b.</i> Procedure		4—3

<i>Paragraph</i>	<i>Page</i>	<i>Paragraph</i>	<i>Page</i>
3. Normal Tuning Procedure	4-3	e. Locating Trouble in the I.F. Amplifier	7-8
a. C.W. (Continuous Wave) Reception..	4-3	f. Locating Trouble in the Heterodyne Oscillator	7-9
b. M.C.W. (Modulated Continuous Wave) Reception.....	4-3	g. Locating Trouble in the R.F. Am- plifier	7-9
c. Voice Reception	4-4	b. Locating Trouble in the B.F.O.....	7-9
d. "HEADPHONE LEVEL" Control	4-4	5. Electron Tube Tests	7-10
e. Speaker "OUTPUT LEVEL" Control..	4-4	6. Voltage and Resistance Measurements.....	7-10
4. Tuning Procedure When Interference is Present	4-4	7. Unit Trouble Shooting and Repair	7-10
a. General	4-4	a. Trouble Shooting	7-10
b. Weak C.W. Signal Separated by One or Two Kilocycles From a Strong Inter- fering Signal	4-4	b. Repair	7-10
c. Strong C.W. Signal Separated by One or Two Kilocycles From a Strong In- terfering Signal	4-5	(1) Electrical Adjustments	7-10
d. M.C.W. Signal With Interference Due to Severe Atmospheric Conditions.....	4-5	(a) Alignment Procedure	7-10
e. M.C.W. Signal With Interference Due to Stronger Undesired M.C.W. Signal	4-5	1. Setting Up Equipment for Alignment	7-10
f. Voice Modulated Signals With Inter- ference Due to Any Type of Un- desired Signal	4-5	2. I.F. Amplifier Alignment	7-10
		3. Heterodyne Oscillator and R.F. Amplifier Alignment Table	7-11
		4. Heterodyne Oscillator Alignment	7-11
		5. R.F. Amplifier Alignment	7-11
		6. B.F.O. Alignment	7-11
		(b) Sensitivity Tests	7-12
		1. Test Limits	7-12
		2. Setting Up Receiver For Sensitivity Tests	7-12
		3. Checking M.C.W. Sen- sitivity	7-12
		4. Checking C.W. Sensitiv- ity	7-13
		(2) Mechanical Adjustments	7-13
		(a) Maintenance and Repair of Tuning Dial Assembly U-501	7-13
		(b) Installation of a New Tun- ing Dial Assembly	7-14
		(c) Typical Repair of Tuning Dial Mechanism	7-14
		8. Coil Winding Data	7-15
SECTION 5—OPERATOR'S MAINTENANCE			
1. Introduction	5-0		
2. Routine Inspection and Routine Check Chart	5-0		
3. Emergency Maintenance	5-1		
a. Notice to Operators	5-1		
b. Replacement of Tubes and Fuses	5-1		
SECTION 6—PREVENTIVE MAINTENANCE			
1. Routine Maintenance Check Charts	6-1		
2. Lubrication	6-4		
a. Lubrication of the Precision Dial Mechanism	6-4		
b. Lubrication of Rotating Shaft Mech- anism	6-5		
3. Uncovering the Equipment	6-5		
SECTION 7—CORRECTIVE MAINTENANCE			
1. General	7-1		
2. Failure Report	7-1		
3. Theory of Trouble Localization	7-1		
4. System Trouble Shooting	7-3		
a. Preliminary Checks	7-3		
b. General — Gain Measurements.....	7-4		
c. Locating Trouble in the Push-Pull Amplifier	7-4		
d. Locating Trouble in the Audio Am- plifier	7-5		
		SECTION 8—PARTS LISTS	
		8-1 Weights and Dimensions of Spare Parts Boxes	8-1
		8-2 Shipping Weights and Dimensions of Spare Parts Boxes	8-1
		8-3 List of Major Units	8-1
		8-4 Combined Parts and Spare Parts List...	8-2
		8-5 Cross Reference Parts List	8-30
		8-6 Color Codes and Miscellaneous Data..	8-32
		8-7 List of Manufacturers	8-35

LIST OF ILLUSTRATIONS

SECTION 1—GENERAL DESCRIPTION		SECTION 3—INSTALLATION	
<i>Figure</i>	<i>Page</i>	<i>Figure</i>	<i>Page</i>
1—1	Radio Receiving Equipment, Model RBS-3	3—1	Packaging Drawing for RBS-3 Equipment
	1—0		3—2
1—2	Navy Type R-303/FRR Radio Receiver	3—2	Radio Receiving Equipment Navy Model RBS-3, Right Rear View
	1—1		3—3
1—3	Navy Type PP-445/FRR Rectifier Power Amplifier	3—3	Radio Receiving Equipment Navy Model RBS-3, General Assembly.....
	1—2		3—4
1—4	Navy Type R-303/FRR Radio Receiver Chassis, Showing Principal Components (Top View)	3—4	Radio Receiving Equipment Navy Model RBS-3, Interconnection Diagram
	1—4		3—5
1—5	Navy Type PP-445/FRR Rectifier Power Amplifier Chassis, Showing Principal Components (Top View)	3—5	Installation of Connector on Coaxial Antenna Cable
	1—5		3—6
1—6	Navy Type R-303/FRR Radio Receiver Chassis, Showing Principal Components (Bottom View)	3—6	Installation Diagram for Speaker Cable Connector, P-902
	1—6		3—7
1—7	Navy Type PP-445/FRR Rectifier Power Amplifier Chassis (View from Bottom)	3—7	Installation Diagram for A.C. Power Cable Connector, J-901
	1—7		3—7
1—8	Rectifier Power Amplifier (Receptacle Box Lowered) Bottom View	SECTION 4—OPERATION	
	1—9	4—1	Radio Receiver Navy Type R-303/FRR Left Front View
1—9	Radio Receiver Chassis (Bottom Rear View)		4—1
	1—9	4—2	Tuning Dial Assembly, U-501, Front View
			4—2
SECTION 2—THEORY OF OPERATION		SECTION 5—OPERATOR'S MAINTENANCE	
2—1	Radio Receiving Equipment, Functional Block Diagram	5—1	Radio Receiver Tube Locations
	2—0		5—2
2—2	Radio Frequency Plate and Converter Grid Circuits	5—2	Rectifier Power Amplifier Tube Locations
	2—1		5—2
2—3	Heterodyne Oscillator Circuits	SECTION 6—PREVENTIVE MAINTENANCE	
	2—2	6—1	Tuning Dial Assembly U-501, Rear View
2—4	Antenna Transformer Assembly, T-501		6—3
	2—3	6—2	Radio Receiver Navy Type R-303/FRR Left Rear View
2—5	Antenna Transformer Circuit		6—4
	2—4	6—3	Radio Receiver Navy Type R-303/FRR Right Rear View
2—6	Automatic Gain Control Circuit		6—5
	2—5	SECTION 7—CORRECTIVE MAINTENANCE	
2—7	Radio Frequency Transformer Assembly, T-502, Plate Side	7—1	Power Supply and Filter Circuits
	2—5		7—1
2—8	Radio Frequency Transformer Assembly, T-502, Converter Grid Side.....	7—2	Stage by Stage Trouble Localization Diagram
	2—6		7—2
2—9	Heterodyne Oscillator Transformer Assembly, T-503	7—3	Rectifier — Power Amplifier, Tube Socket Diagram
	2—6		7—5
2—10	Intermediate Frequency Circuits	7—4	Radio Receiver, Tube Socket Diagram
	2—7		7—7
2—11	Beat Frequency Oscillator Circuit	7—5	Test Assembly for Sensitivity Tests....
	2—8		7—12
2—12	Audio Filter and Receiver Output		
	2—10		
2—13	Phone Jacks Circuits		
	2—11		
2—14	Push-Pull Amplifier Circuit		
	2—12		
2—15	Power Supply and Filter Circuits		
	3—1		

<i>Figure</i>		<i>Page</i>	<i>Figure</i>		<i>Page</i>
7-6	Coil Winding Diagrams	7-17	7-17	Output Transformer, T-903	7-28
7-7	Coil Winding Diagrams	7-19	7-18	Complete Schematic Diagram of Rec- tifier Power Supply Unit Navy Type PP-445/FRR	7-29, 7-30
7-8	1st I.F. Transformer Details	7-21	7-19	Complete Schematic Diagram of Radio Receiver Navy Type R-303/FRR	7-31, 7-32
7-9	2nd I.F. Transformer Details	7-21	7-20	Rectifier — Power Amplifier, Wiring Diagram	7-33, 7-34
7-10	3rd I.F. Transformer Details	7-22	7-21	Radio Receiver, Wiring Diagram	7-35, 7-36
7-11	B.F.O. Transformer Details	7-22	7-22	Tuning Dial Assembly U-501, Ex- ploded View	7-37, 7-38
7-12	Receiver Output Transformer, T-508..	7-23			
7-13	Low Pass Filter Reactor, L-521	7-24			
7-14	Power Supply Filter Choke, L-901	7-25			
7-15	Power Supply Transformer, T-901	7-26			
7-16	Input Transformer, T-902	7-27			

LIST OF TABLES

SECTION 1—GENERAL DESCRIPTION

1-1	Shipping Data	1-3
-----	---------------------	-----

SECTION 5—OPERATOR'S MAINTENANCE

5-1	Routine Check Chart	5-0
5-2	Symptoms of Fuse Failure	5-1
5-3	Fuse Location	5-1

SECTION 6—PREVENTIVE MAINTENANCE

6-1	Routine Maintenance Check Chart Underway — Daily and Weekly.....	6-1
6-2	Routine Maintenance Check Chart Underway — Monthly	6-1
6-3	Routine Maintenance Check Chart Underway — Quarterly	6-2
6-4	Routine Maintenance Check Chart Underway — Semi-Annually	6-2
6-5	Routine Maintenance Check Chart Underway — Annually	6-2

6-6	Navy Model Test Equipments	6-4
-----	----------------------------------	-----

SECTION 7—CORRECTIVE MAINTENANCE

7-1	Stage Gains Chart	7-4
7-2	Rectifier Power Amplifier Unit, Volt- age and Resistance Chart	7-5
7-3	Radio Receiver, Voltage Chart	7-6
7-4	Radio Receiver, Resistance Chart.....	7-6
7-5	Rated Tube Characteristics	7-8

SECTION 8—PARTS LISTS

8-1	Weights and Dimensions of Spare Parts Boxes	8-1
8-2	Shipping Weights and Dimensions of Spare Parts Boxes	8-1
8-3	List of Major Units	8-1
8-4	Combined Parts and Spare Parts List....	8-2
8-5	Cross Reference Parts List	8-30
8-6	Color Codes and Miscellaneous Data..	8-32
8-7	List of Manufacturers	8-35

INSTALLATION RECORD

Contract Number NObsr 43286

Date of Contract, 6 May, 1949

Serial Number of equipment

Date of acceptance by the Navy.....

Date of delivery to contract destination

Date of completion of installation

Date placed in service

Blank spaces above shall be filled in at time of installation.

SAFETY NOTICE

THE ATTENTION OF OFFICERS AND OPERATING PERSONNEL IS DIRECTED TO CHAPTER 67 OF BUREAU OF SHIPS MANUAL OR SUPERSEDING INSTRUCTIONS ON THE SUBJECT OF "RADIO-SAFETY PRECAUTIONS TO BE OBSERVED".

THIS EQUIPMENT EMPLOYS VOLTAGES WHICH ARE DANGEROUS AND MAY BE FATAL IF CONTACTED BY OPERATING PERSONNEL. EXTREME CAUTION SHOULD BE EXERCISED WHEN WORKING WITH THE EQUIPMENT. DO NOT CHANGE TUBES OR MAKE ADJUSTMENTS INSIDE EQUIPMENT WITH THE HIGH VOLTAGE SUPPLY ON. UNDER CERTAIN CONDITIONS DANGEROUS POTENTIALS MAY EXIST IN CIRCUITS WITH POWER CONTROLS IN THE OFF POSITION DUE TO CHARGES RETAINED BY CAPACITORS.

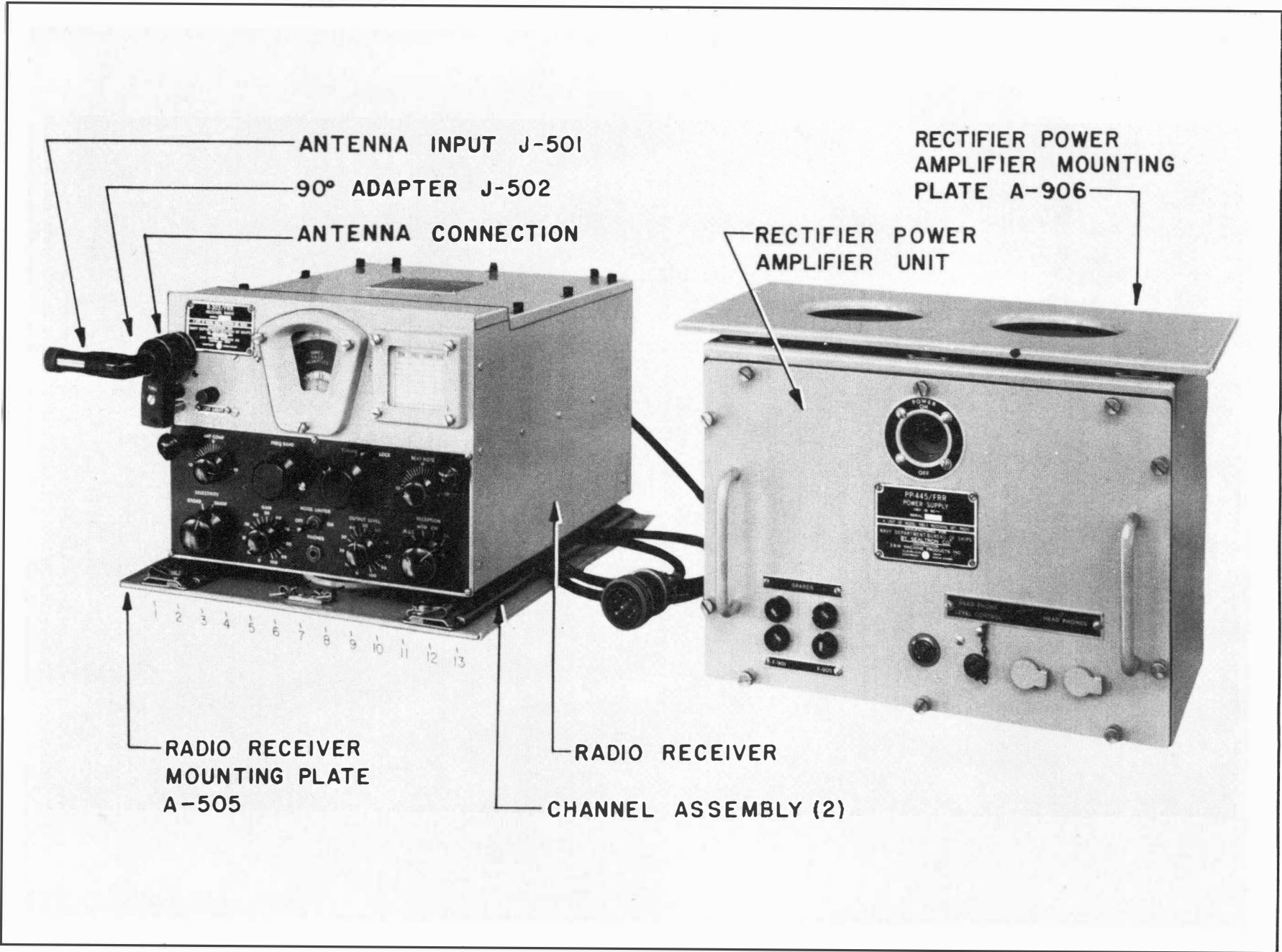

Figure 1-1. Radio Receiving Equipment, Model RBS-3

SECTION I GENERAL DESCRIPTION

I. QUICK REFERENCE DATA.

a. GENERAL.—Navy Model RBS-3 Receiving Equipment is designed for use aboard U. S. Navy vessels or at Naval radio shore stations. The receiver is a 14 tube superheterodyne with a frequency range of 2 to 20 megacycles covered in four bands. It can be used to receive either A1, A2, or A3 signals depending upon the position of the "RECEPTION" switch. The equipment is capable of delivering eight watts of audio power to the loudspeaker with less than 10 percent distortion. The equipment is ruggedly constructed for use under adverse conditions and is complete except for headphones, loudspeaker, loudspeaker cable, and power source cable. (See Figure 1-1).

b. FREQUENCY RANGE.—The receiver has a fre-

quency range continuous from 2 to 20 megacycles in four calibrated tuning bands.

<u>Band</u>	<u>Frequency Range (in megacycles)</u>
1	2 to 3.6
2	3.6 to 6.5
3	6.5 to 11.4
4	11.4 to 20.

c. POWER REQUIREMENTS.—The equipment is designed to operate from 115 volt A.C. single phase, 50/60 cycle power source. Power consumption does not exceed 120 watts.

d. ANTENNA REQUIREMENTS.—Provisions have been incorporated to permit satisfactory performance of the equipment with any antenna having a capacitance between 80 to 500 micromicrofarads.

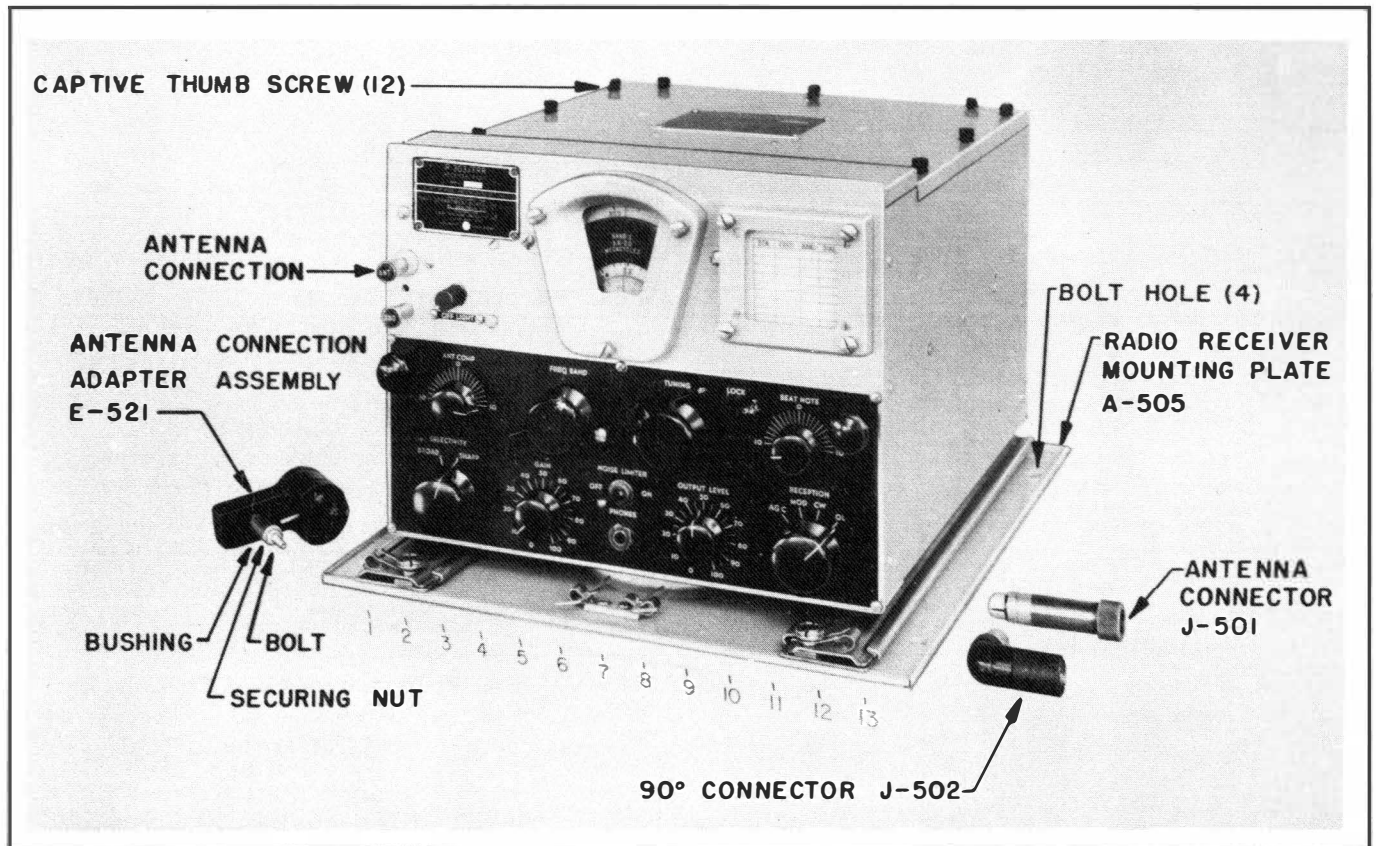

Figure 1-2. Navy Type R-303/FRR Radio Receiver

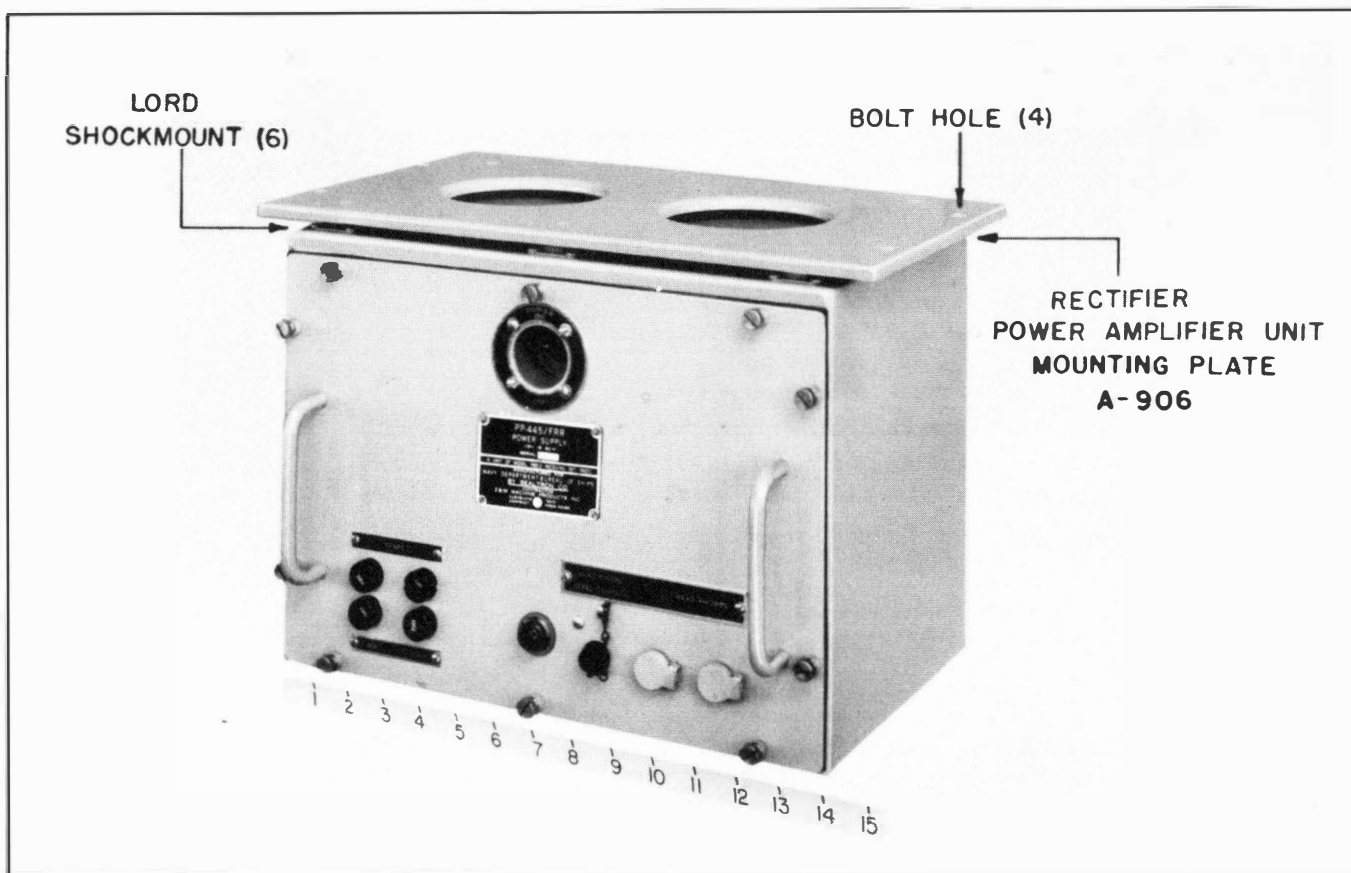

Figure 1-3. Navy Type PP-445/FRR Rectifier Power Amplifier

**2. EQUIPMENT SUPPLIED WITH NAVY
MODEL RBS-3:**

Quantity Name of Unit or Accessory

1 ea. Radio Receiver (Type R-303/FRR) complete with:
 1 Electron Tube Type 6V6-GT
 2 Electron Tube Type 6H6
 4 Electron Tube Type 6SG7
 3 Electron Tube Type 6SJ7
 1 Electron Tube Type 6SK7
 1 Mounting Plate A-505
 1 Antenna Connection Adapter Assembly E-521, Navy Type number 49120
 1 Rectifier Power Amplifier Unit (Type PP-445/FRR) complete with:

1 Electron Tube Type 5U4G
 2 Electron Tube Type 6V6GT
 1 Mounting Plate A-901
 1 Accessories Kit consisting of:
 1 Interconnecting Cable & Plug Assembly
 1 Antenna Terminal Adapter E-522
 1 Antenna Plug J-501, Navy type number 49121
 1 90° Adapter J-502, Navy type number 49151
 1 A.C. Input Plug J-901, AN number AN-3106A-18-22S(02-4M)
 1 Loudspeaker Cable Plug P-902, AN number AN-3106A-18-4P(02-4M)
 1 Equipment Spare Parts Box (Type M) Containing:
 1 Set of Spare Parts
 2 Instruction Books.

TABLE I-1 SHIPPING DATA

Shipping Box No.	Contents		Over-All Dimensions			Volume	Weight
	Name	Designation	Height	Width	Depth		
1	Receiver, Power Supply & Accessories	RBS-3	14 ³ / ₄	42 ¹ / ₄	16 ³ / ₄	6.06	160
2	Spare Parts Box	RBS-3	11 ¹ / ₈	23 ³ / ₄	14 ⁷ / ₈	2.27	75

3. EXPORT PACKING OF RBS-3.

Equipment is packed for export shipment which necessitates packing the unit and the carton of spare parts in individual wooden boxes to reduce weight and size of package and facilitate handling. The method of packing is as follows:

a. The radio receiver with mounting plate attached is packed with a dehydrant in an inner carton which is enclosed in a water-proof heat-sealed bag. This package is fitted into an outer carton.

b. The Rectifier, Power-Amplifier Unit with mounting plate attached is packed as described in the preceding paragraph a. The accessories are included in this package. Then both units are packed in a wooden box.

c. The equipment spare parts are carefully packed in a metal box. Where necessary, individual parts are enclosed in a heat-sealed water-proof bag. Each metal box is encased in a wooden packing crate. A water-proof liner is placed between the box and the wooden crate.

4. EQUIPMENT REQUIRED BUT NOT SUPPLIED.

a. HEADPHONES.—The headphones used should have an impedance of 600 ohms and are designated by the standard Navy type number 49016. No special plugs or adaptors are required for this equipment.

b. LOUDSPEAKER.—The standard Navy type loudspeaker is used.

c. SPEAKER CABLE.—The speaker cable used is Navy type DHFA-3. No standard plugs or adapters are supplied with the speaker cable at the speaker end, as several types of speaker may be used. The length of cable will vary according to the installation.

d. POWER CABLE.—Navy type MCOS-2 power cable is used with a standard Navy type plug at the

power source. The length of the cable will vary depending upon the installation.

5. MARKING OF SPARE PARTS.

a. EQUIPMENT SPARE PARTS.—The equipment spare parts which have received anti-fungus treatment have the letters MFP stamped on the boxes in which they are packed. The inside carton is stamped with the date and the following notation: "These spare parts are anti-fungus treated."

b. STOCK SPARE PARTS.—The stock spare parts have the date and the following notation stamped on the outside carton: "These spare parts are anti-fungus treated."

6. PHYSICAL DESCRIPTION OF EQUIPMENT.

Navy model RBS-3 Radio Receiving Equipment consists of two major units, the Radio Receiver R-303/FRR and the Rectifier Power Amplifier Unit PP-445/FRR. It is designed for table mounting exclusively and is equipped with mounting plates by which it is secured to a standard Navy radio operating table. The receiver is equipped with an antenna connection adapter assembly which is mounted on the front panel and blocks off the antenna and ground binding posts.

The mounting plate supplied with the Receiver unit enables it to be mounted on the top surface of a standard Navy table while the Rectifier Power Amplifier Unit utilizes a mounting plate which permits it to be mounted on the under side of the table, directly below the Receiver. The two units are connected by means of the interconnecting cable, W-101, supplied with the equipment. A loudspeaker, and associated cabling, is to be located at any convenient point; these items are not supplied as a part of the equipment. Detailed installation instructions are given in Section 3.

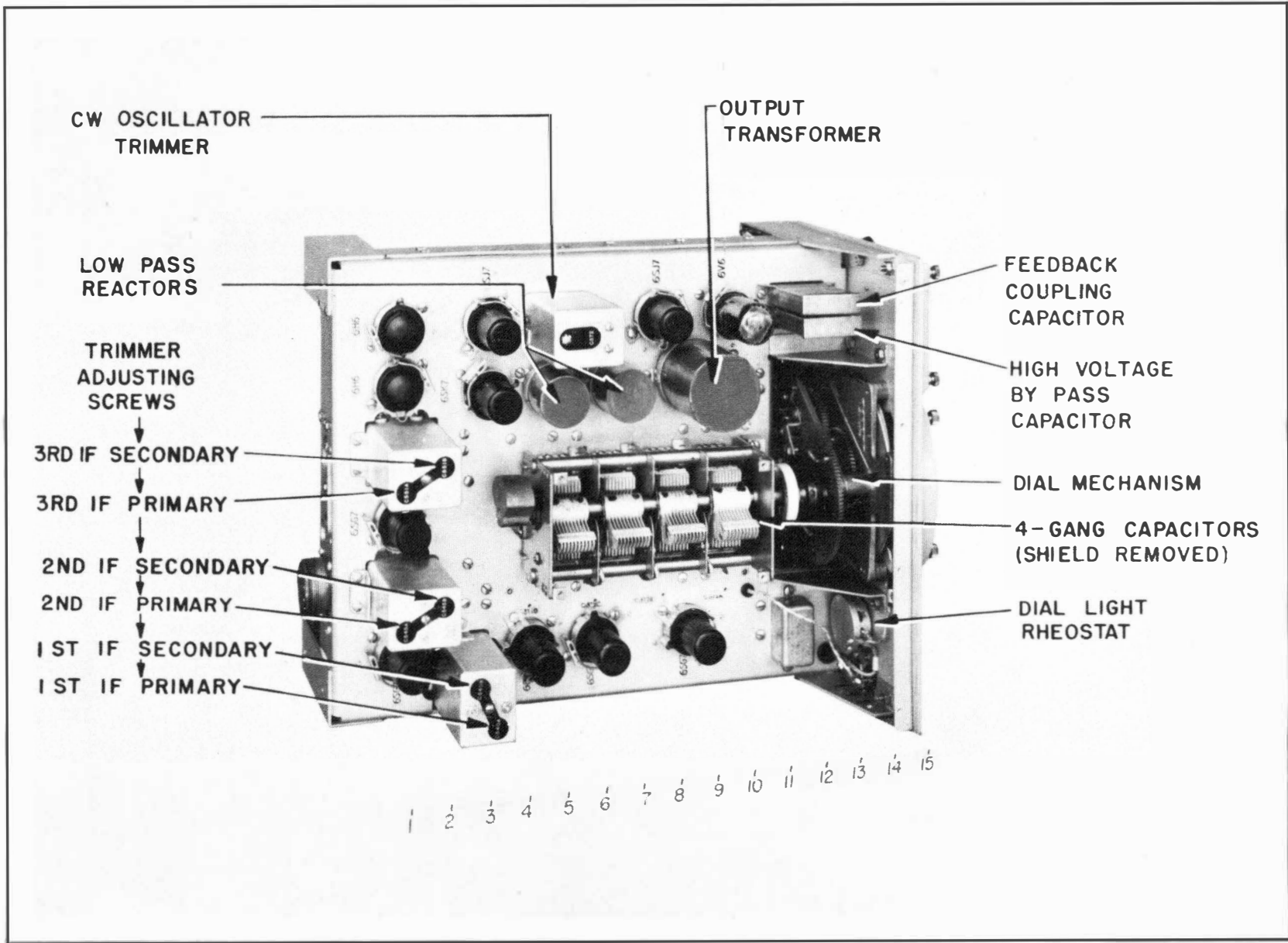

Figure 1-4. Navy Type R-303/FRR Radio Receiver Chassis Showing Principal Components. (Top View).

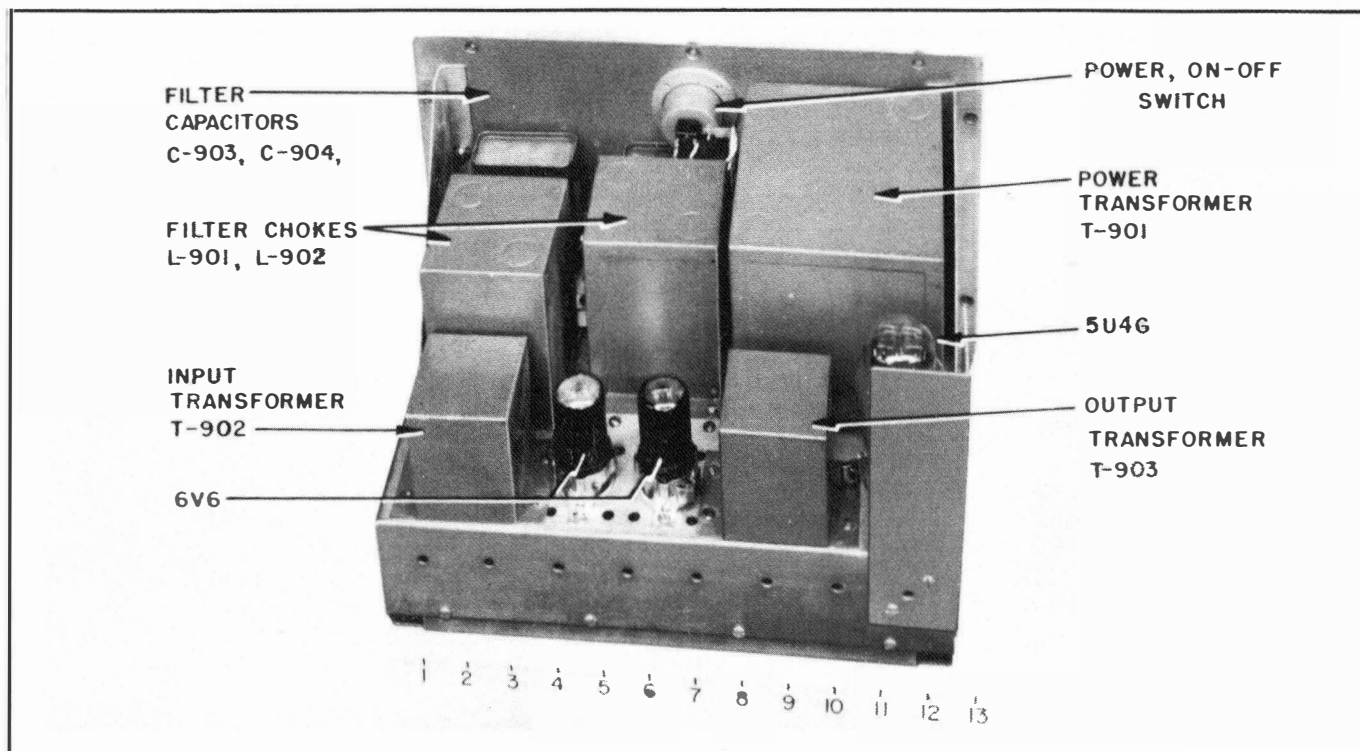

Figure 1-5. Navy Type PP-445/FRR Rectifier Power Amplifier Chassis. (Top View).

a. RADIO RECEIVER.

(1) CHASSIS.—The receiver chassis is constructed of aluminum alloy sheet bent into conventional form and spot welded at each corner. The corners of the chassis are supported by four legs. Each leg is mounted on a vertical snubbing Lord shock mount. The front and rear shock mounts on either side of the chassis are tied together by stainless steel rails (runners) extending from the front to the rear of the chassis external to cabinet. These rails engage channels fastened to the mounting plate. The receiver is locked into place by tightening the thumb screws on the channels. It may be pulled from its cabinet for inspection, maintenance, or adjustment by loosening the 29 holding screws.

(2) FRONT PANEL.—The front panel of the receiver unit contains all the controls necessary for operation except the power on-off switch, which is on the Rectifier Power Amplifier Unit. The function of each control is marked on the surrounding panel surface. Functional details of each control are found in paragraph 1c of Section 4. For reference logging convenience a station log chart is located on the front panel; the protective covering may be removed by removing the four thumb screws.

(3) CABINET.—The receiver cabinet is made from sheet aluminum bent to the proper form. There are 29 screws which hold the chassis to the cabinet and all must

be removed if the chassis is to be withdrawn. An opening is provided in the rear for access to P-504 which connects with J-504 at one end of the interconnecting cable W-101. For access to the I.F. trimmers, the top of the cabinet is easily removed by removing the 12 captive thumb screws which hold it in place. (See Figure 1-2).

b. RECTIFIER POWER AMPLIFIER UNIT.—

(1) CHASSIS.—The Navy type PP-445/FRR Rectifier, Power Amplifier Unit (Figure 1-3) is constructed on a spot welded sheet steel chassis about three inches deep. A receptacle box is hinged to the lower rear edge of the chassis by means of two screw hinges. In its normal position this box is within the chassis and flush with its lower edge (Figure 1-7), but it may be lowered to provide access to the input and output transformer terminals and other components mounted beneath the chassis. (See Figure 1-8). Mounted in this receptacle box are the A.C. power input receptacle (P-901), the loudspeaker receptacle (J-902), and the interconnecting cable receptacle (J-903).

(2) FRONT PANEL.—The front panel not only forms an integral part of the chassis assembly but also serves to complete the enclosure of the cabinet assembly. Two large handles, mounted one at either side of the panel, permit the chassis to be easily installed or removed from the cabinet.

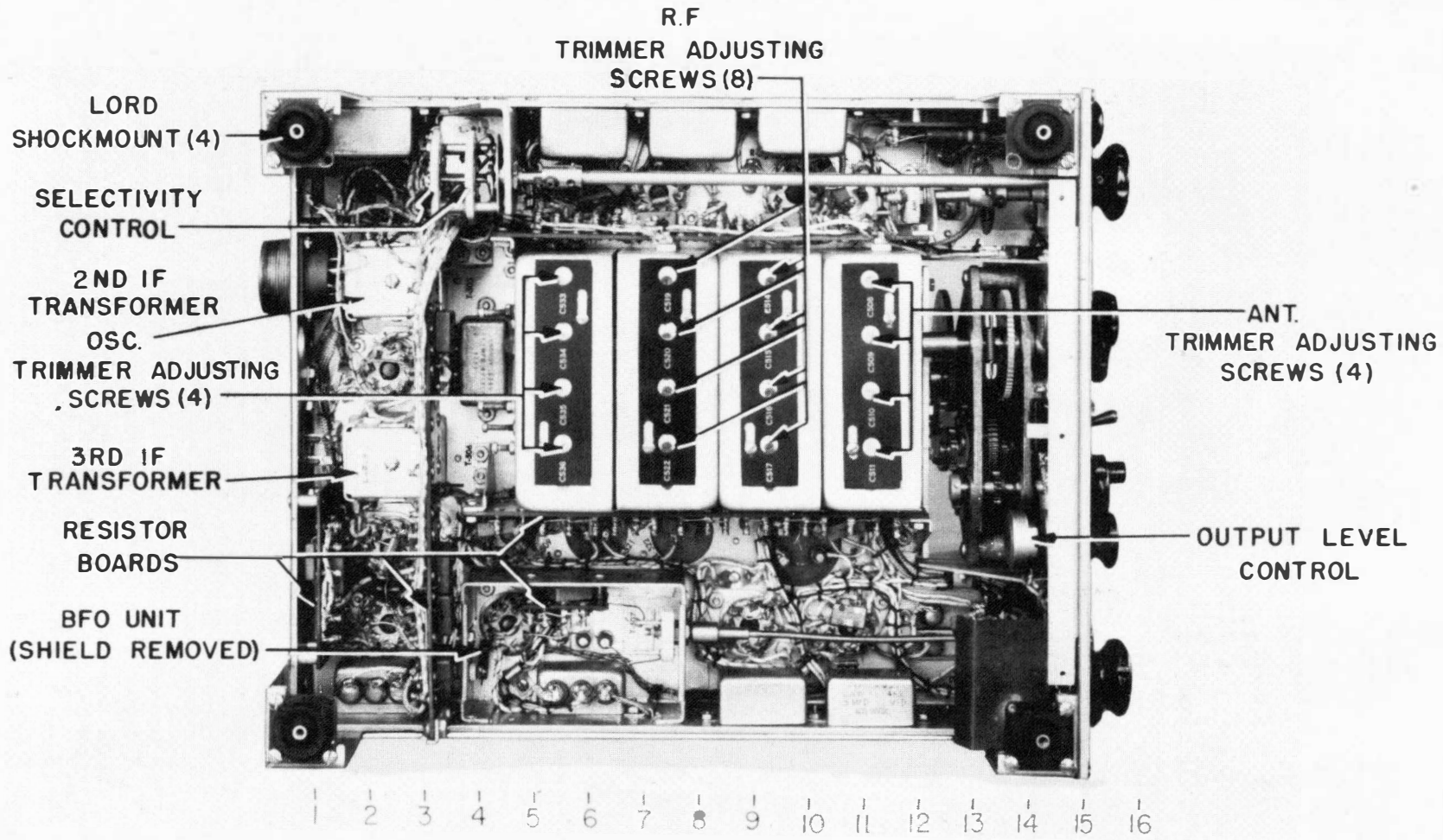

Figure 1-6. Navy Type R-303/FRR Radio Receiver Chassis, Showing Principal Components. (Bottom View).

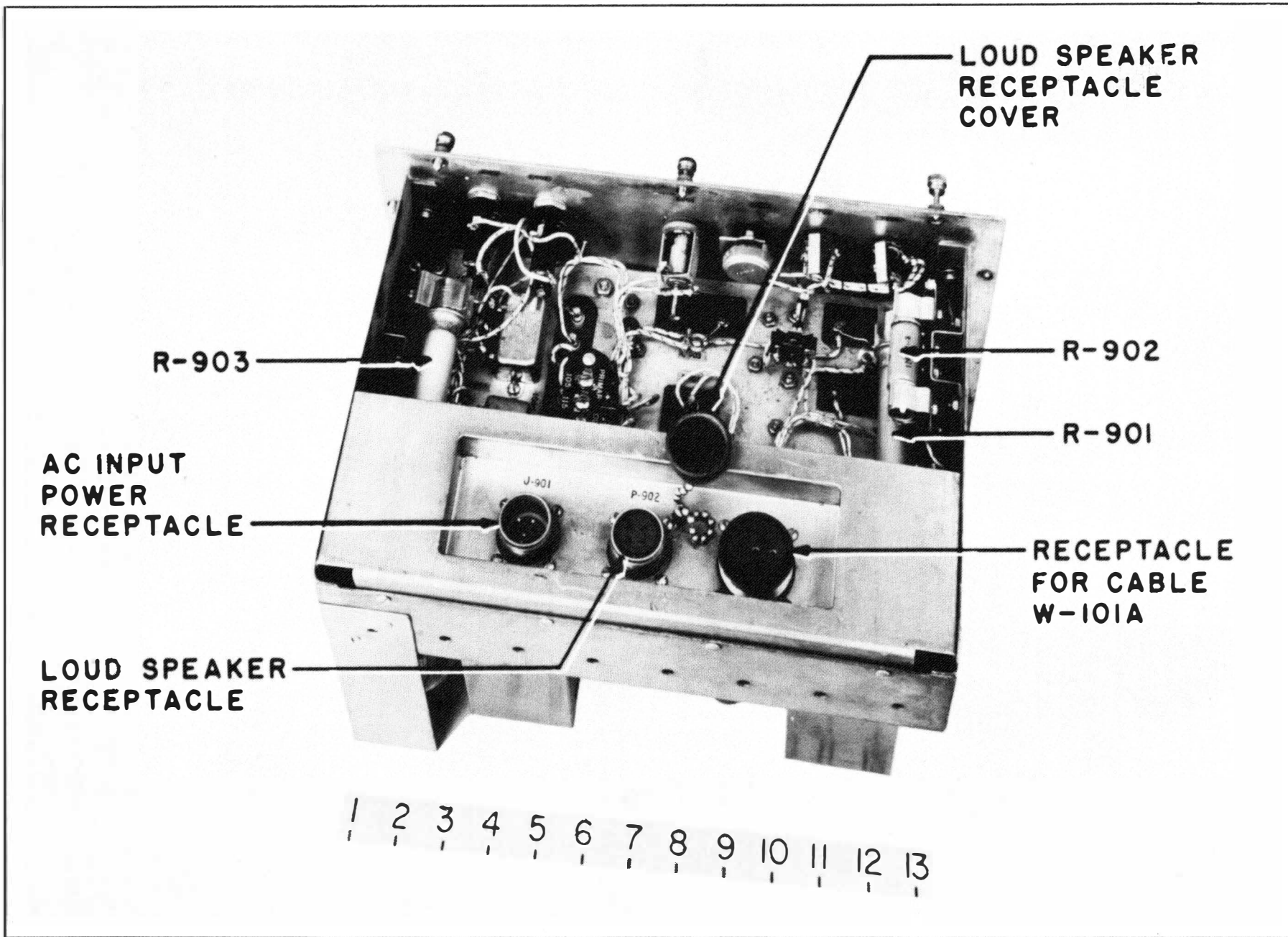

Figure 1-7. Navy Type PP-445/FRR Rectifier Power Amplifier Chassis. (View from bottom).

(3) CABINET.—The chassis is secured to its cabinet by 10 captive thumb screws which pass through the front panel. The cabinet forms a complete enclosure for the unit. An opening through the bottom permits access to the receptacle box. Six shock mounts are fastened to the top surface of the cabinet for use in attaching it to the mounting rack.

7. ELECTRICAL DESCRIPTION OF THE EQUIPMENT.

a. RADIO RECEIVER.

(1) TOP OF CHASSIS.—Mounted above the chassis are the main four-section ganged capacitor (C-512A, C-512B, C-512C and C-512D), all electron tubes, the beat frequency oscillator transformer (T-507), the low pass filter reactors (L-521 and L-522), and the output transformer (T-508). (See Figure 1-4). The three intermediate frequency transformer assemblies (T-504, T-505 and T-506), located on top of the chassis, are mounted in rectangular openings, through which they project about $1\frac{1}{8}$ inches. Their symbol designations (T-504, T-505 and T-506) are stamped on the bottom and may be viewed from beneath the chassis.

(2) BOTTOM OF CHASSIS.—On the under side of the chassis are the antenna, the radio frequency, and the oscillator transformer assemblies (T-501, T-502, T-503), three long resistor-capacitor boards, three short resistor-capacitor boards, and all filter and bypass capacitors with the exception of C-562, C-574 and C-575. All wiring, except that integral with the units on top of the chassis or required for their connection into the circuit, is contained below the chassis. (See Figure 1-6).

The following components, mounted beneath the chassis, have their shafts brought out to the front panel, either directly or by means of extensions:

"SELECTIVITY" switch.

"RECEPTION" switch.

Vernier capacitor for "BEAT NOTE" adjustment.

Connector P-504 is mounted at the rear of the receiver chassis. Its seven pin terminals carry the receiver power input and audio power output voltages.

(3) CONTROL PANEL.—Mounted behind the control panel are the following controls:

(a) two potentiometers, the "OUTPUT LEVEL" control (R-533), and the "GAIN" control (R-537);

(b) the dial light rheostat (R-546);

(c) the tuning dial mechanism (U-501).

(See Figures 1-4, 1-6, and 1-9).

b. RECTIFIER, POWER-AMPLIFIER UNIT.

(1) TOP OF CHASSIS.—Above the chassis are located three electron tubes (V-901, V-902 and V-903), the power transformer (T-901), two filter chokes (L-901 and L-902), the audio input and audio output transformer (T-902 and T-903), and three filter capacitors (C-903, C-904 and C-905.) The only visible wiring passes up from the input power receptacle through fuse (F-902) to the "POWER, ON-OFF" switch (S-901) mounted on the rear of the central panel. (See Figure 1-5).

(2) BOTTOM OF CHASSIS.—The wiring connections for the fuses (F-901 and F-902), the pilot light (I-901), the "HEADPHONE LEVEL CONTROL" (R-905), and the headphone jacks (J-904 and J-905) are on the rear of the panel, beneath the chassis floor. Capacitor C-902 and dual capacitor C-901 are also mounted beneath the chassis floor. (See Figure 1-8).

8. SUMMARY OF PERFORMANCE.

(For test details see sections 5, 6, and 7).

a. SENSITIVITY: C.W. or M.C.W. With a signal-to-noise voltage ratio of 10:1 on C.W. or 3.2:1 on M.C.W. the sensitivity of a typical receiver is below 8 microvolts on all bands. Minimum sensitivity requirements are as follows: less than 8 microvolts on band 1 and 2, less than 15 microvolts on band 3, and less than 25 microvolts on band 4.

b. SELECTIVITY AT 100X.—The selectivity of a typical receiver at 100 times the input required for normal sensitivity and at the "BROAD" position of the "SELECTIVITY" switch is 42.6 kilocycles; allowable limits are 20 to 58 kilocycles. At the "SHARP" position, the typical selectivity is 25.6 kilocycles with allowable limits of 7 to 32 kilocycles.

c. IMAGE REJECTION AT 20 MEGACYCLES.—Image rejection voltage ratio at 20 megacycles is 25000:1 in a typical receiver. Minimum allowable ratio is 3000:1.

d. I.F. REJECTION AT 2 MEGACYCLES.—In a typical receiver the I.F. rejection voltage ratio is 25000:1 with a minimum allowable voltage ratio of 3000:1.

e. AUDIO FREQUENCY RESPONSE.—The high frequency response is attenuated because a 3,500 cycle low-pass filter is used in the audio amplifier. For the same input the output voltage at 1,000 cycles is one hundred times larger than that at 6,000 cycles.

f. OSCILLATOR RADIATION.—At 14.0 megacycles the oscillator of a typical receiver radiates with a power of only 192 micromicrowatts (240 microvolts across 300 ohms). Radiation must be below 400 micromicrowatts to meet test requirements.

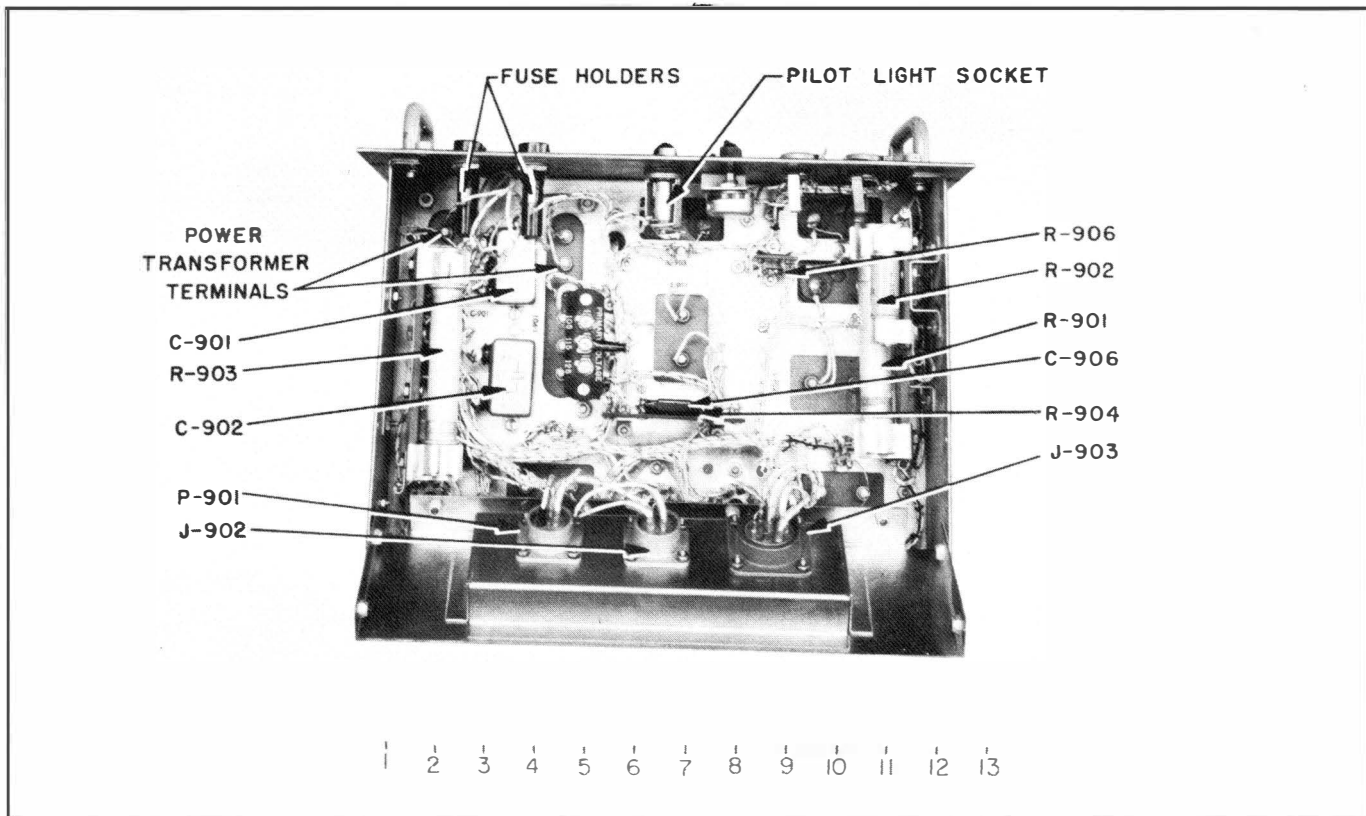

Figure 1-8. Rectifier Power Amplifier (Receptacle Box Lowered). Bottom View.

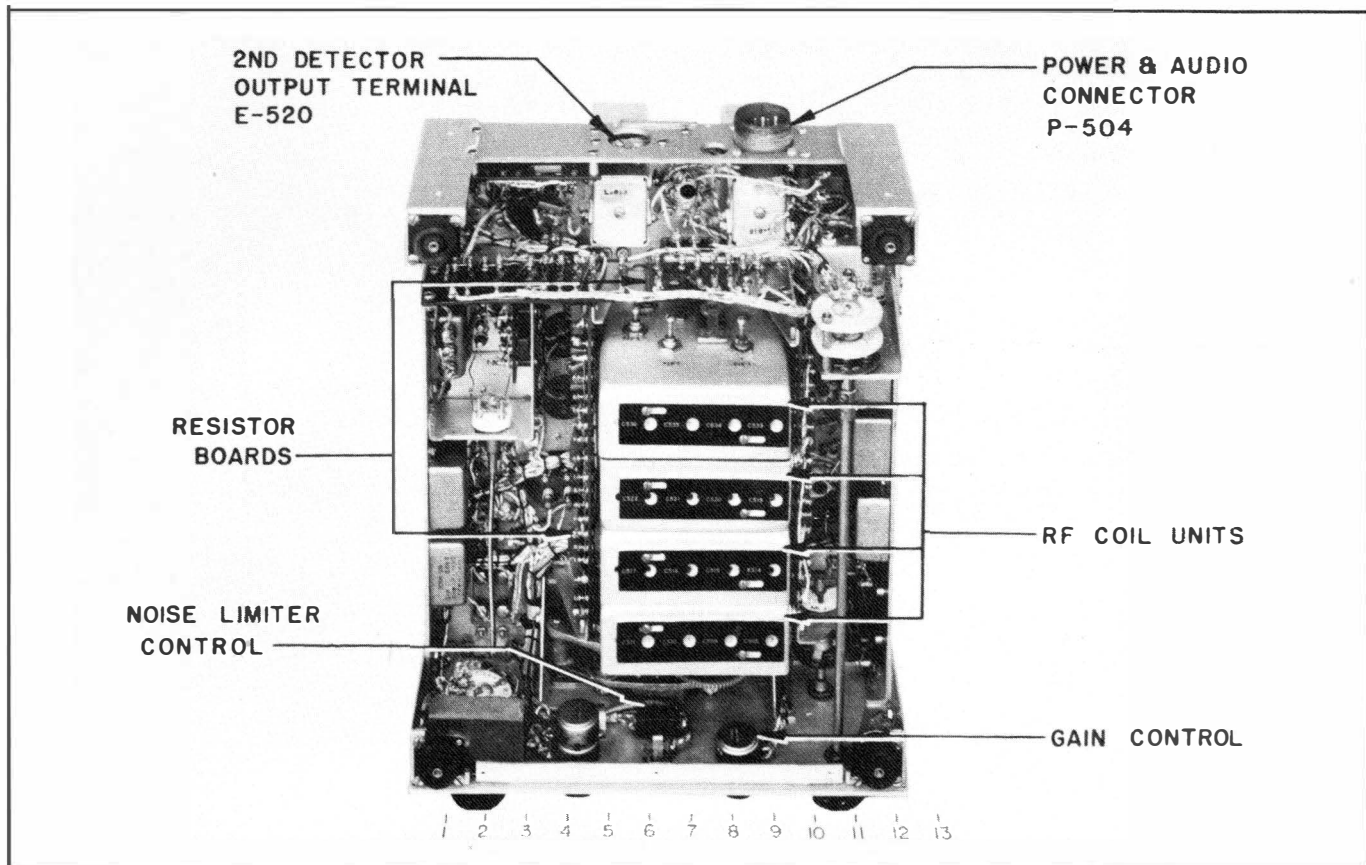

Figure 1-9 Radio Receiver Chassis (Bottom Rear View).

g. POWER OUTPUT M.C.W.—With 100 microvolts input the power output from the phone jack of a typical receiver is 150 milliwatts with 1.7 percent distortion; maximum allowable distortion is 7 percent. When the push-pull amplifier is used, the power output of a typical receiver is 8 watts with 1.7 percent distortion; maximum allowable distortion is 10 percent.

b. DIAL CALIBRATION.—The dial is calibrated with an error of less than 1 percent at all points.

i. A.G.C. CHARACTERISTIC.—With the input varying from 100 microvolts to 100,000 microvolts, the voltage ratio of the receiver output varies less than 2:1. Maximum allowable variation is 4:1.

j. NOISE LIMITER.—At all positions of the "RECEPTION" switch, the noise limiter circuit of a typical receiver attenuates noise pulse peaks so the voltage ratio of signal to noise is 6:1; a signal modulated 30 percent at 1,000 cycles is relatively unaffected. A minimum ratio of only 2:1 is required to meet test limits.

SECTION 2 THEORY OF OPERATION

I. INTRODUCTION.

The Radio Receiving Equipment RBS-3 is designed for use aboard U. S. Navy vessels and/or at shore stations. The receiver is a manually controlled 14 tube superheterodyne. It has a frequency range of 2 to 20 megacycles in four overlapping tuning bands and can receive A1, A2, or A3 signals.

To facilitate analysis of the electrical circuits of the equipment, a functional block diagram (Figure 2-1) is shown. Complete schematic diagrams are shown in Section 7, Figures 7-18 and 7-19, and simplified schematics are included as needed in the text.

In Figure 2-1, the path of the signal can be traced from the antenna to the phones or speaker. Paragraphs 3 and 4 give a detailed analysis of the individual circuits.

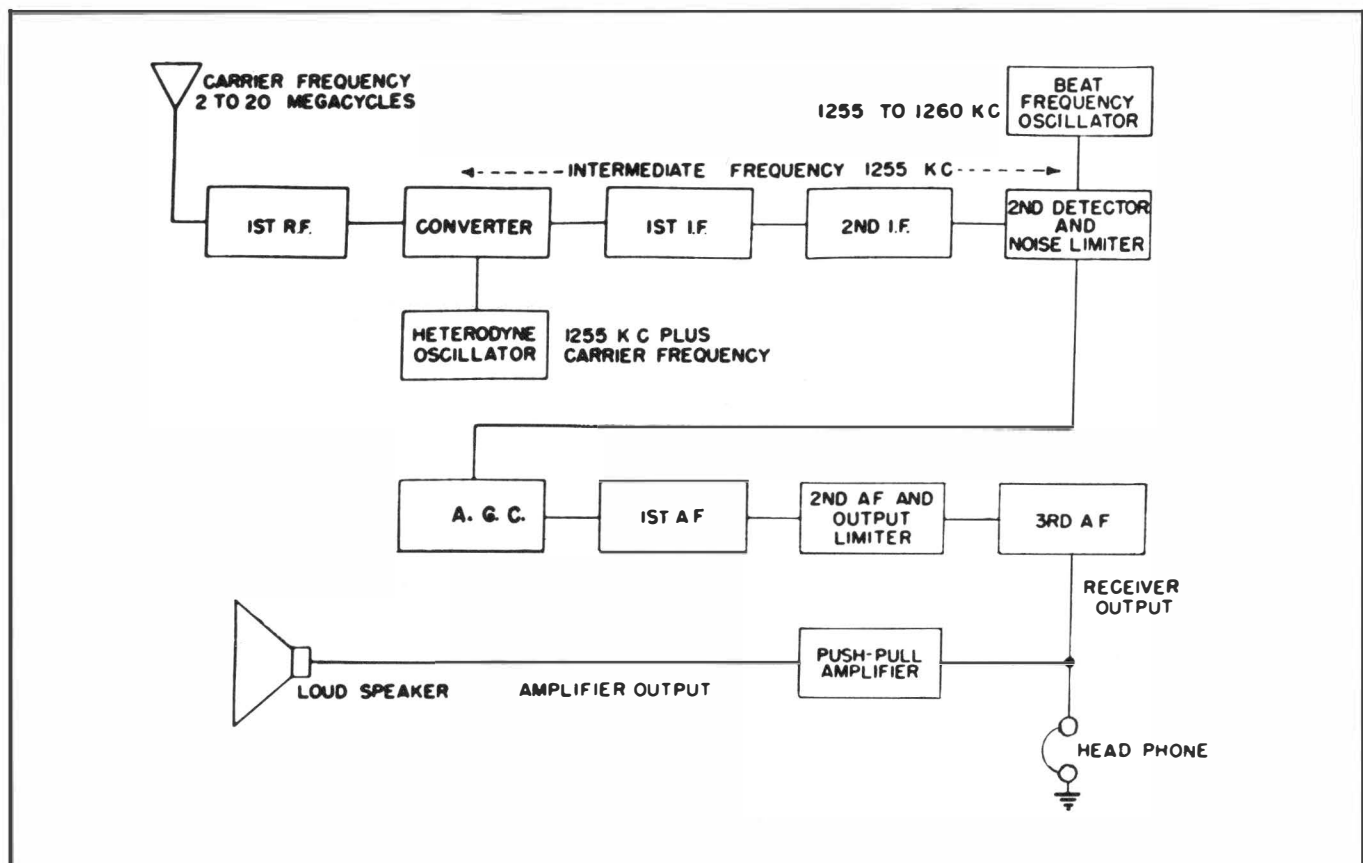

Figure 2-1. Radio Receiving Equipment, Functional Block Diagram

2. THE PATH OF THE SIGNAL.

The radio frequency signal passes from the antenna through the cables and connectors into the receiver at "ANT" terminal on the panel. It is amplified by the radio frequency amplifier consisting of a 6SG7 pentode tube, V-501 tuned in both the grid and plate circuits.

The signal output of the R.F. stage is link-coupled to the tuned grid circuit of another 6SG7 pentode tube, V-502, employed as a frequency converter.

The heterodyne oscillator circuit employs a type 6SJ7 pentode tube, V-503, in a tuned electron-coupled oscillator circuit. The oscillator output is capacitively coupled to the cathode of the converter tube, V-502. As the heterodyne oscillator output frequency is always 1255 kilocycles higher than the signal frequency at any position of the tuning dial, an intermediate frequency of 1255 kilocycles is produced in the plate circuit of the converter tube.

This 1255 kilocycle intermediate frequency signal is then amplified through two stages, consisting of V-504 and V-505. These tubes are both 6SG7 types and are transformer coupled by three I.F. transformers, T-504, T-505, and T-506. The coupling between the primaries and secondaries of the first two transformers may be varied to control the selectivity of the intermediate frequency amplifier.

The amplified 1255 kilocycle intermediate frequency signal is then fed to one side of a 6H6 double diode tube, V-506. One half of this diode functions as a conventional diode detector stage. The other half of the tube is employed as a noise limiter by acting to clip the peaks of noise pulses.

The beat frequency oscillator, used for CW reception, employs a 6SJ7 pentode tube, V-508. This tube is connected as an electron-coupled oscillator which generates a local signal of frequency near the I.F. This oscillator output is capacitively coupled to the second detector diode.

A portion of the output of the third I.F. transformer (T-506) is capacitively coupled to the A.G.C. circuit, which employs a 6H6 tube, V-507. With the "RECEPTION" switch in the "AGC" position, full A.G.C. voltage is applied to the R.F. amplifier, to the converter, to the first I.F. amplifier, and to the first A.F. amplifier tubes.

The audio output of the second detector is amplified by the first audio stage which employs a type 6SK7 pentode, V-509. It is fed through a low pass filter to the second audio stage which employs a 6SJ7 pentode, V-510. The circuit of the second audio stage provides variable output limiting.

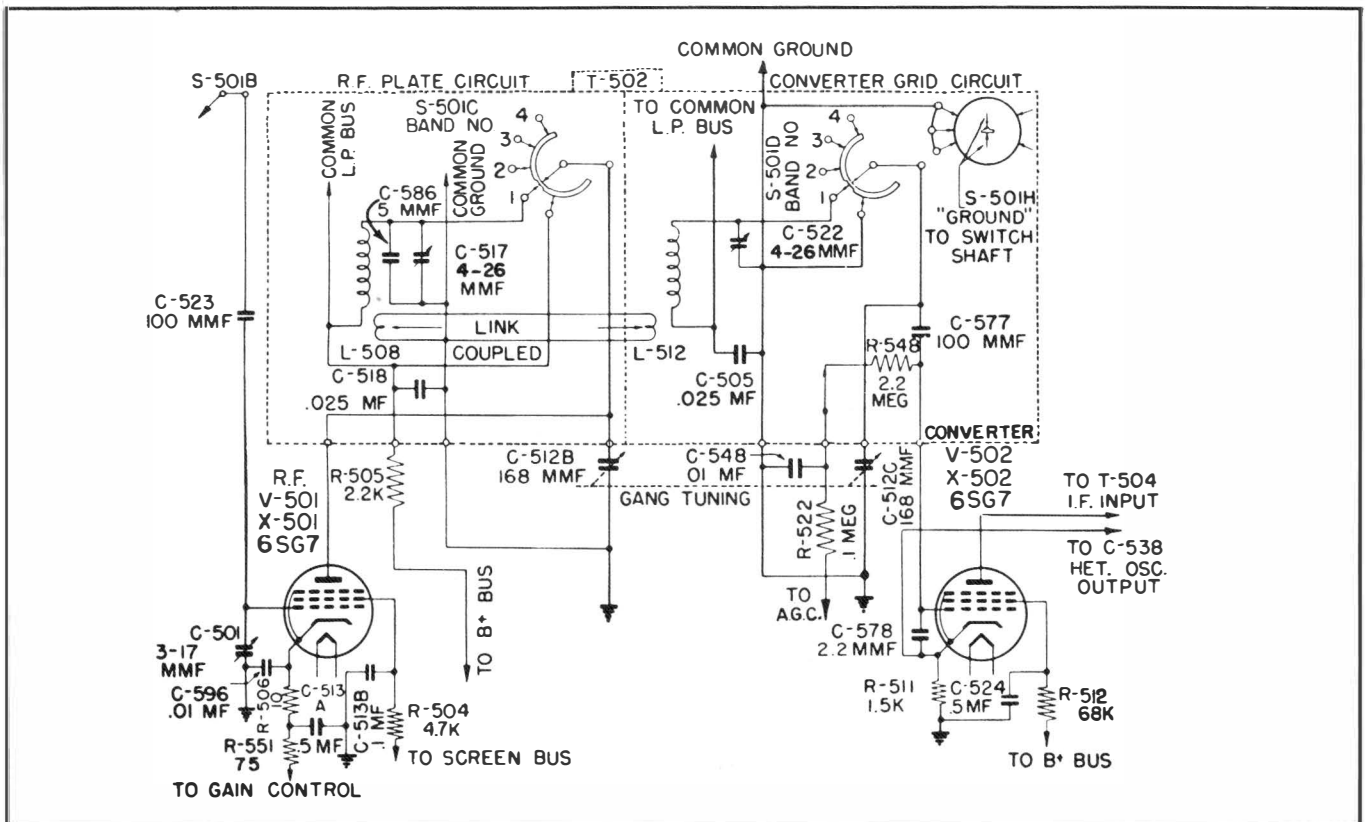

Figure 2-2. Radio Frequency Plate and Converter Grid Circuits

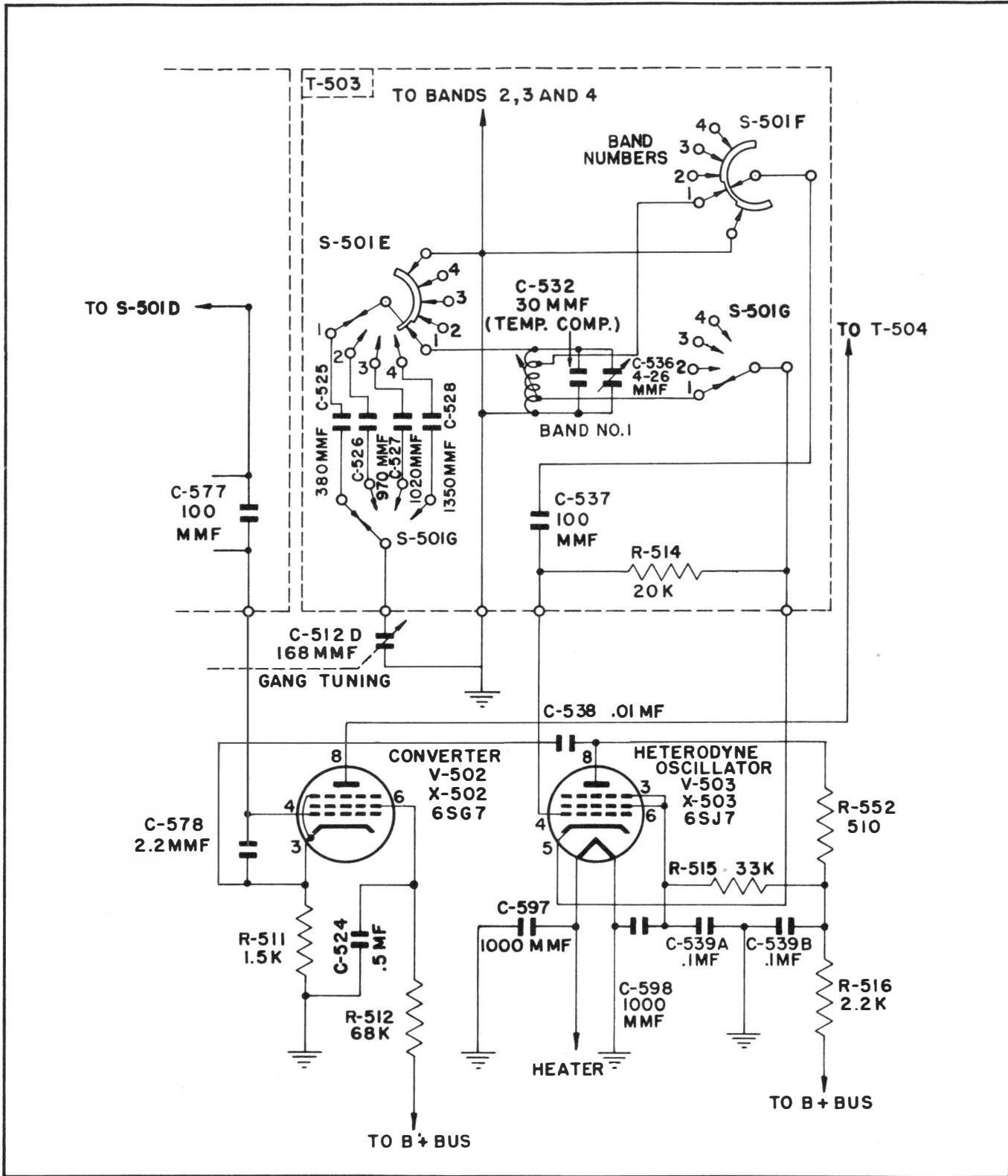

Figure 2-3. Heterodyne Oscillator Circuits

The signal from the plate of the second audio tube is further amplified by the third audio stage which is a 6V6-GT output tube, V-511, transformer coupled through T-508 to headphone jacks, J-503, J-904, and J-905 and then through T-902 to the input of the two 6V6-GT's operating as a push-pull amplifier. (See Figures 7-18 and 7-19). The final audio signal may be heard either through the headphones connected to the output of the third A.F. stage or through a loudspeaker connected to the output of the push-pull amplifier.

3. CIRCUIT ANALYSIS OF RADIO RECEIVER.

a. THE RADIO FREQUENCY CIRCUITS.

(1) General (See Figures 2-2 and 2-3).

The R.F. circuits include the R.F. amplifier, the converter, and the heterodyne oscillator stages (tubes V-501, V-502, V-503 respectively). Transformer coils, trimmers, and fixed capacitors for the tuned circuits of these stages are contained in individually shielded units (T-501, T-502, and T-503). The transformer assembly T-502 consists of two shielded compartments welded together.

The eight section, four position gang switch (S-501A to S-501H inclusive), marked "FREQ. BAND" on the panel, selects the proper set of transformer coils and capacitors for the frequency band in use. Each section of this switch is located in the same shielded compart-

ment as the coils it switches. Switch section S-501H, mounted within the shield of the grid transformer compartment of T-502, has the special function of attenuating oscillator radiation. In all positions of the switch, this section grounds the frequency band switch shaft. In addition, the switch shorts the unused R.F. transformer coils to prevent absorption and loss of signal energy. Tuning of the transformer coils selected is accomplished by the four gang variable tuning capacitor, C-512A to C-512D inclusive.

(2) THE RADIO FREQUENCY AMPLIFIER (V-501) (See Figures 2-2 and 2-5).

The signal from the antenna terminal E-517 marked "ANT" on the front panel of the receiver, passes through the frequency band switch section S-501A to the untuned primary of antenna transformer assembly T-501 (See Figure 2-4). From the secondary of the transformer, which is tuned by section C-512A of the four gang tuning capacitor, the signal passes through switch section S-501B and the coupling capacitor C-523 to the grid of the 6SG7 R.F. amplifier tube, V-501. The 3 to 17 micromicrofarad variable capacitor C-501, connected from the grid of tube V-501 to ground, and controlled by the "ANT COMP" knob on the panel, tunes the antenna circuit. The D.C. voltage developed by the A.G.C. circuit (Figure 2-6) is applied to tube

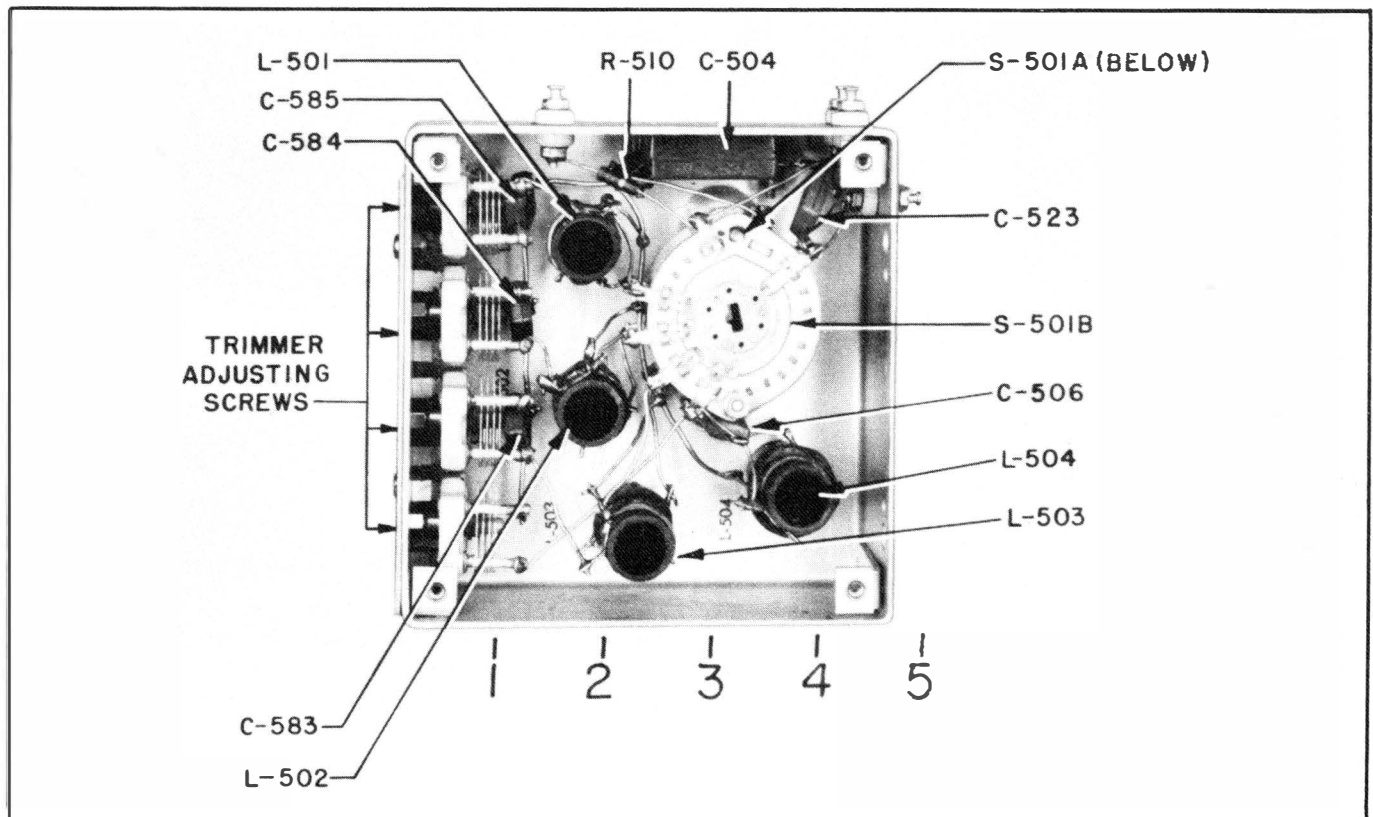

Figure 2-4. Antenna Transformer Assembly, T-501

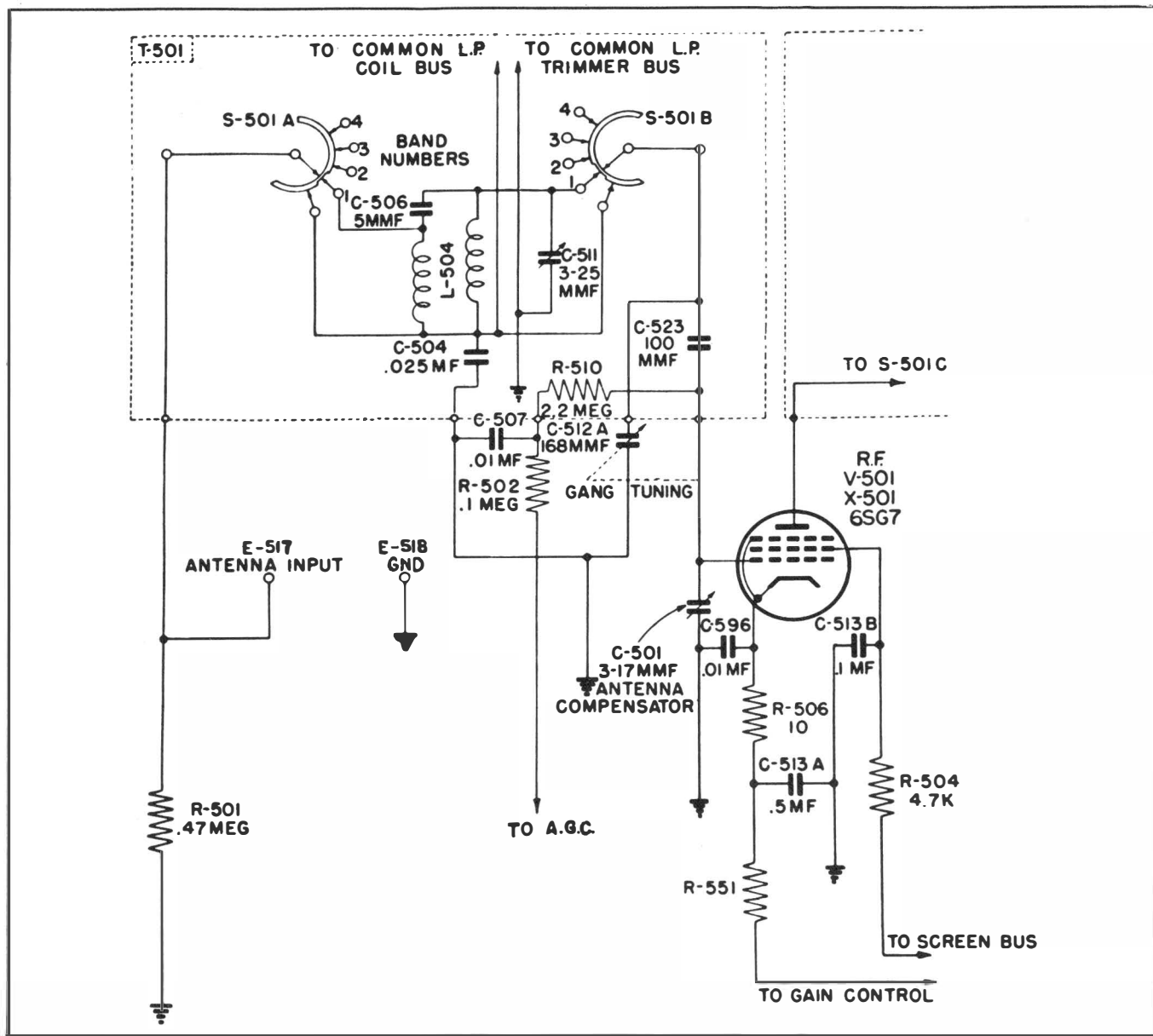

Figure 2-5. Antenna Transformer Circuit

V-501 through resistors R-502 and R-510. The gain of the R.F. tube V-501, together with that of the two I.F. tubes, V-504 and V-505, is controlled by returning the cathodes of the tubes to the "GAIN" control potentiometer R-537 (See Figure 7-19). The potentiometer R-537 forms part of a voltage divider network (R-537, R-543, R-544, R-572, R-576, R-577 and C-575) connected from the plate supply to ground. Screen voltage for the R.F. amplifier V-501 is obtained from this voltage divider through the series resistor R-504.

The amplified R.F. signal passes from the plate of tube V-501 through band switch section S-501C to the primary of the R.F. plate transformer assembly T-502 (See Figure 2-7 and 2-8). Transformer T-502 is com-

posed of two separate shielded sections welded together, one enclosing the plate transformer for the R.F. amplifier V-501 and the other enclosing the grid transformer for the converter V-502. The secondary of the R.F. plate transformer and the primary of the converter grid transformer are link coupled. The primary of the R.F. plate transformer is tuned by section C-512B of the four gang tuning capacitors, and the secondary of the converter grid transformer is tuned by section C-512C.

(3) THE CONVERTER (V-502). (See Figures 2-2 and 2-3).

The converter stage consists of a 6SG7 pentode, V-502, its associated tuned circuit, resistors and by-pass capacitors. From the tuned secondary of the converter grid

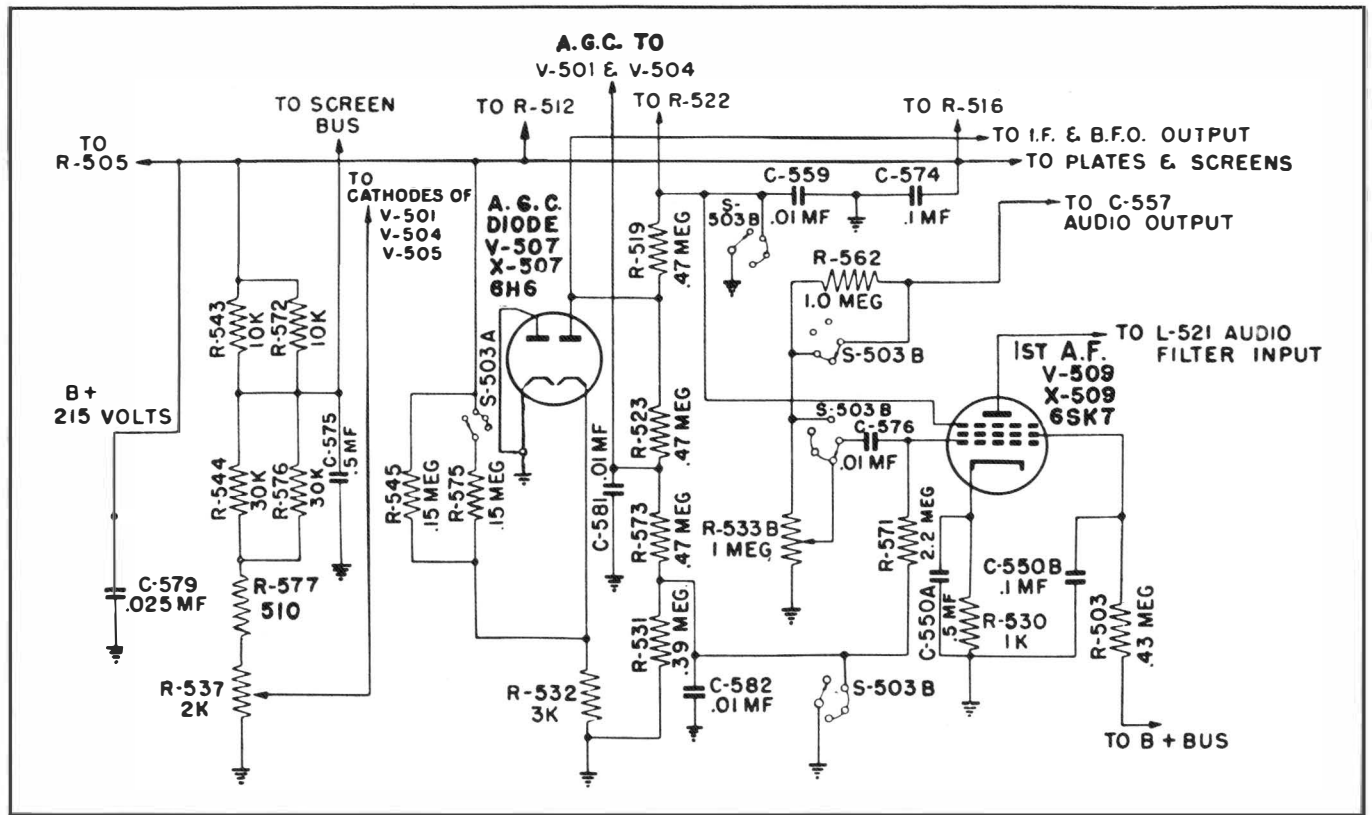

Figure 2-6. Automatic Gain Control Circuit

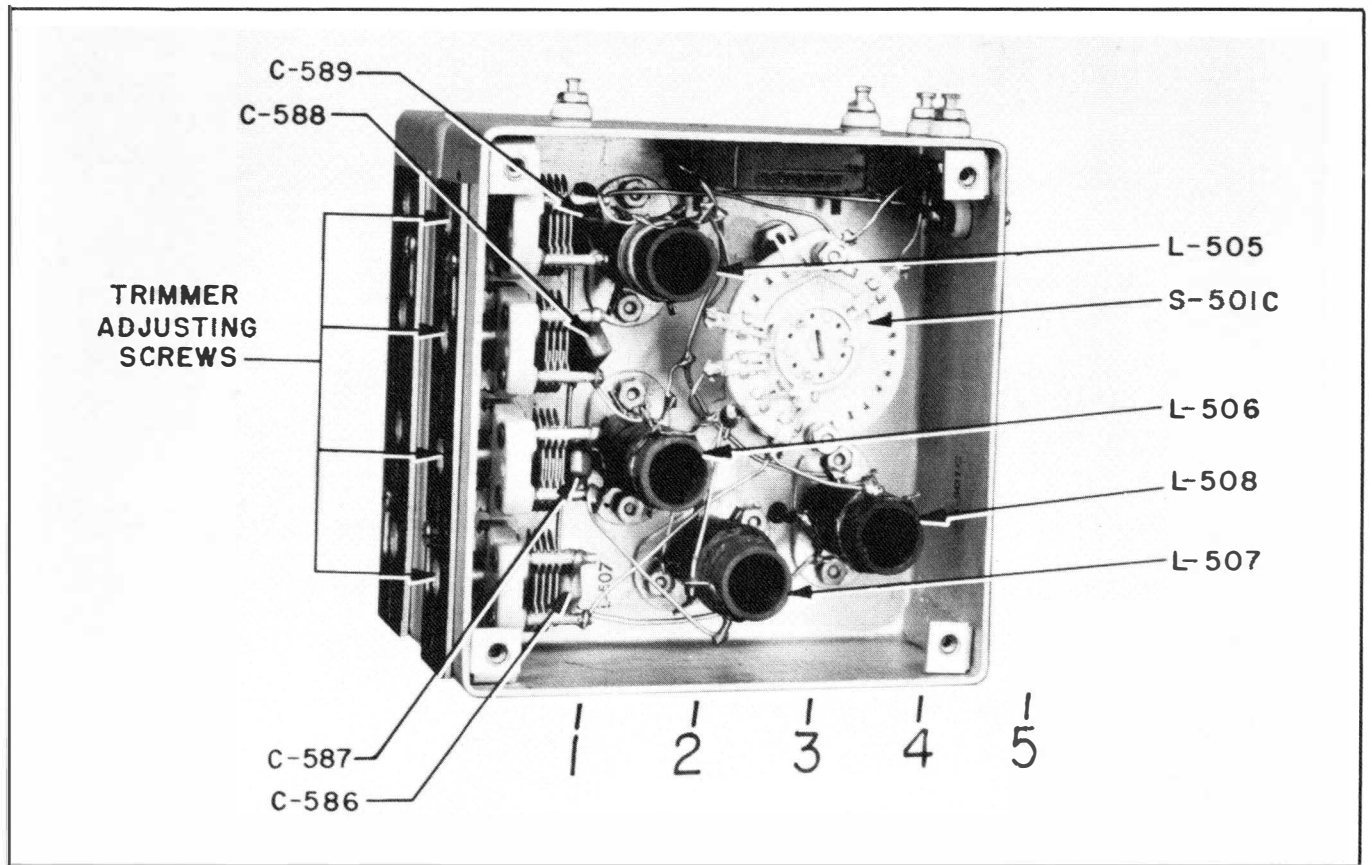

Figure 2-7. Radio Frequency Transformer Assembly, T-502, Plate Side

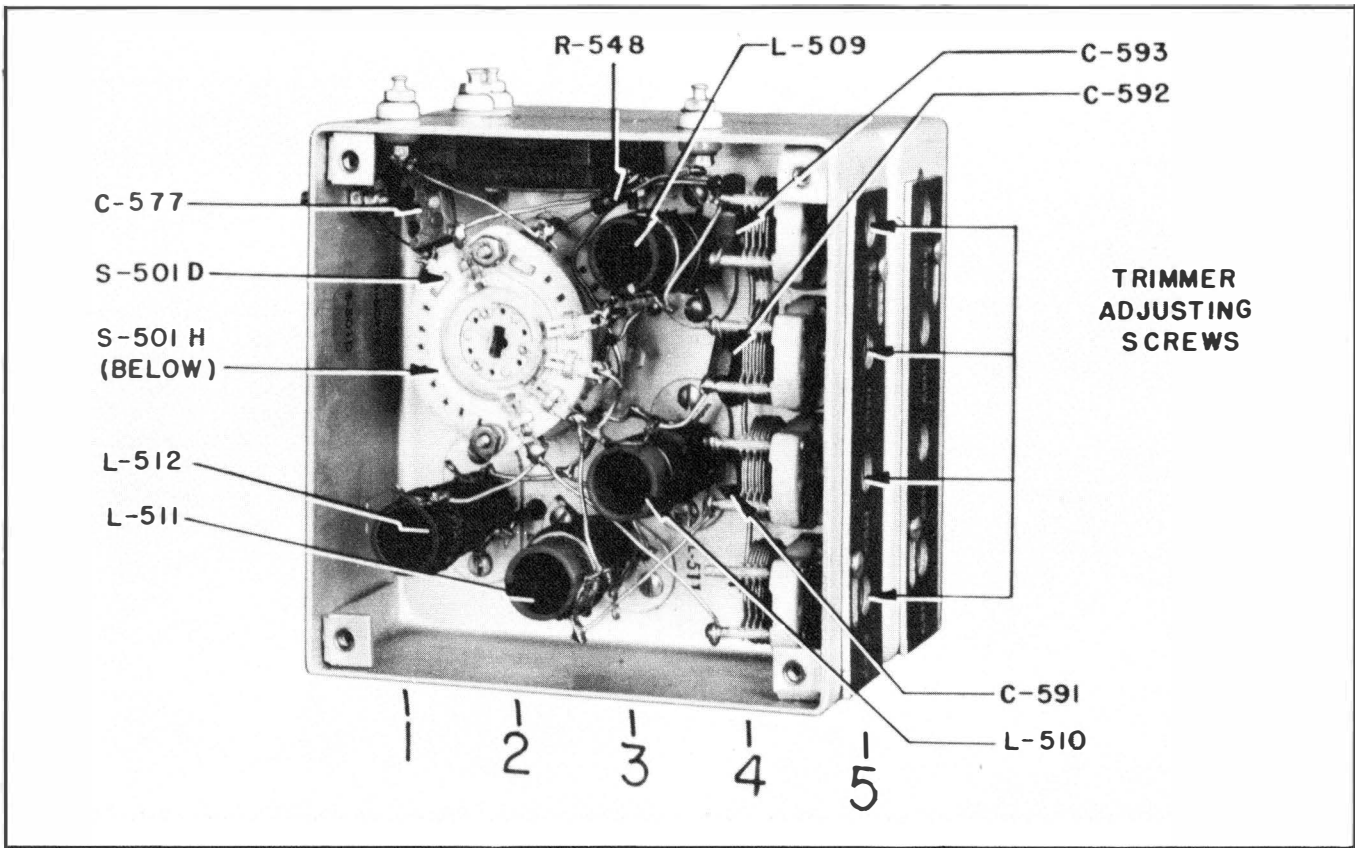

Figure 2-8. Radio Frequency Transformer Assembly, T-502, Converter Grid Side

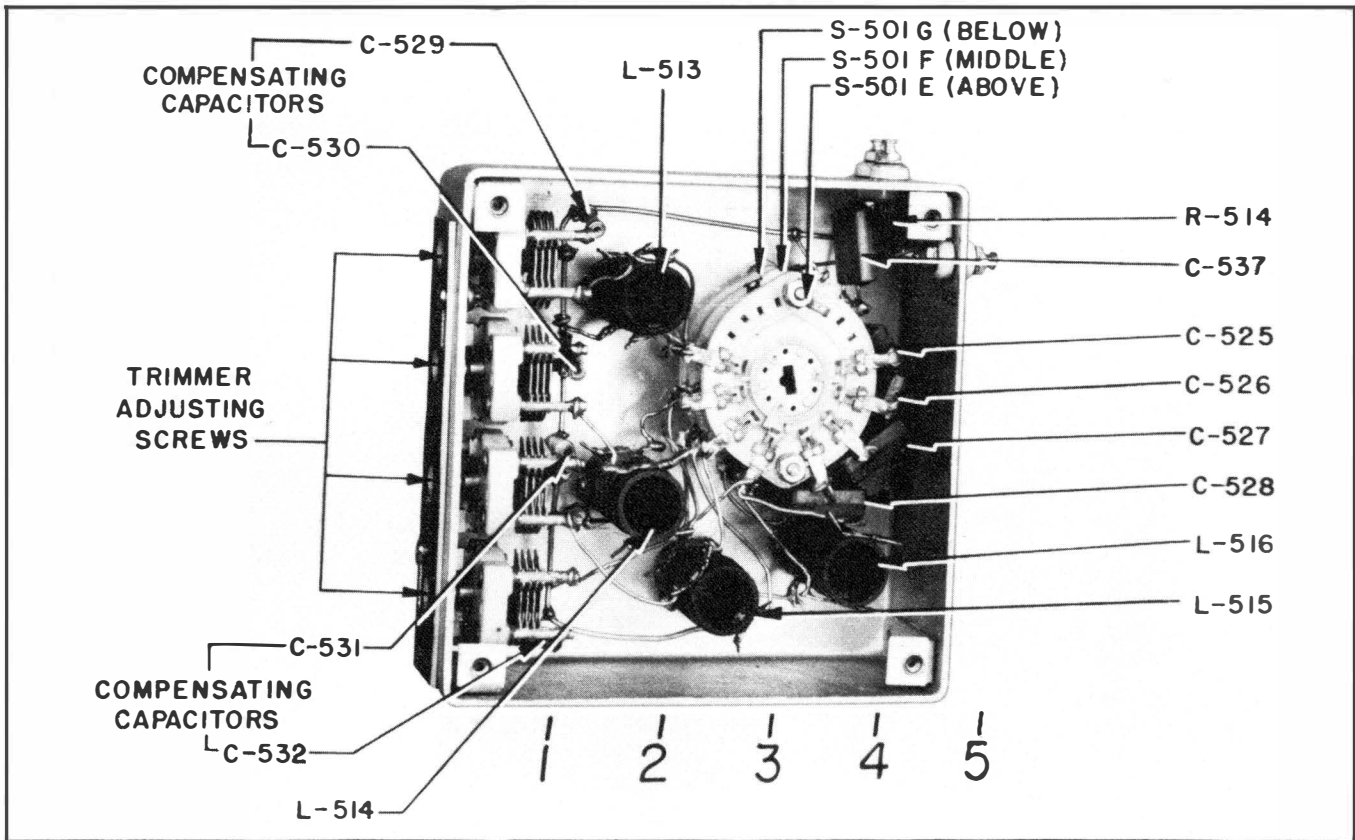

Figure 2-9. Heterodyne Oscillator Transformer Assembly, T-503

transformer (in transformer assembly T-502), the signal is fed through band switch section S-501D and coupling capacitor C-577 to the grid of the tube V-502. Simultaneously, the output from the heterodyne oscillator V-503 modulates the cathode of tube V-502 through the coupling capacitor C-538. The oscillator frequency is maintained 1255 kilocycles higher than the signal frequency (dial reading) at all positions of the tuning dial. In the converter tube V-502, the signal frequency and the local oscillator frequency combine (beat) to produce an intermediate frequency (I.F.) signal of 1255 kilocycles which is tuned by the primary of the first I.F. transformer T-504. A.G.C. voltage is also applied to the converter grid through resistors R-522 and R-548.

(4) THE HETERODYNE OSCILLATOR (V-503)
(See Figure 2-3).

The heterodyne oscillator consists of a 6SJ7 pentode tube V-503, the shielded transformer assembly T-503, a tuning capacitor C-512D (The section furthest from the front panel), and associated resistors and by-pass capacitors. These comments form a tunable electron coupled oscillator designed to provide maximum stability of frequency under variation of supply voltage and of temperature and humidity. (See Figure 2-9).

Switch sections S-501E, S-501F and S-501G, located within transformer enclosure T-503, select the proper

coil taps and padding capacitors for use on the frequency band selected. Band switch section S-501G is one switch wafer. However, it is shown as two switch sections on the schematic diagrams (Figures 2-3 and 7-1) because each side of the switch wafer has a separate electrical function. A set of contacts on one side of the switch wafer connects the cathode of tube V-503 to the proper oscillator coil. The set of contacts on the other side, in conjunction with switch section S-501E connects the tuning capacitor C-512D in series with the proper padding capacitor, for use on the frequency range selected. The fixed padding capacitors (C-525 to C-528 inclusive) are high-quality silvered mica instead of the usual variable series padder. This type is used for reasons of stability. For the low frequency tracking adjustment of each band, the inductance of the transformer coils L-513 to L-516, inclusive, (Figures 2-9 and 7-19) is varied.

Caution

READ SECTION 7, PARAGRAPH 7b(a)3,
BEFORE ADJUSTING THE ABOVE MENTIONED COILS.

b. THE INTERMEDIATE FREQUENCY CIRCUITS (V-504, V-505). (See Figure 2-10).

The intermediate frequency amplifier comprises the

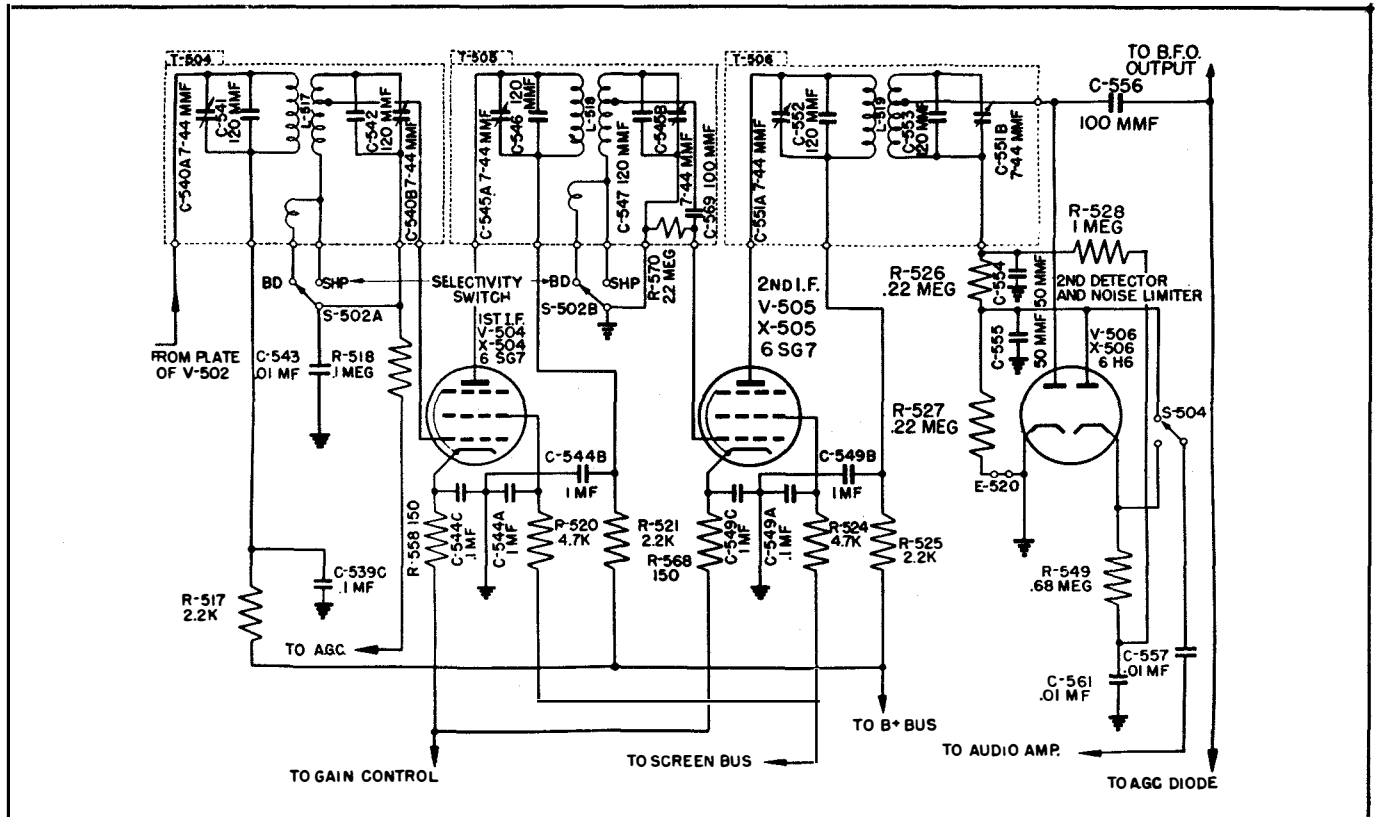

Figure 2-10. Intermediate Frequency Circuits

two 6SG7 pentodes, V-504, V-505, the transformers T-504, T-505 and T-506, and associated resistors and by-pass capacitors. The I.F. amplifier operates at a frequency of 1255 kilocycles. The input signal voltage to the amplifier passes from the plate circuit of the converter tube V-502, through the transformer T-504 and is applied to the grid of the first I.F. amplifier tube V-504. The amplified signal from the plate of this tube is then coupled to the grid of the second I.F. amplifier tube V-505 through the second I.F. transformer T-505.

By means of the two-section, the position "SELECTIVITY" switch S-502, the coupling between the primaries and secondaries of the first and second I.F. transformers may be varied to control the selectivity of the receiver. The greater the coupling, the less the selectivity, and the tuning of the receiver becomes broader. In the "SHARP" position of the panel control, this switch provides for reception under conditions of severe interference from adjacent signal channels.

The gain of the first I.F. amplifier tube, V-504, is controlled by A.G.C. voltage applied to its grid through resistor R-518, and transformer coil L-517 (in T-504). Screen voltage for both I.F. amplifier tubes is obtained from the voltage divider network composed of the "GAIN" control potentiometer R-537, the fixed resistors R-543, R-544, R-572, R-576 and R-577, and capacitor

C-575. The potentiometer R-537 controls the gain of both I.F. amplifier tubes V-504 and V-505, as well as the gain of the R.F. amplifier V-501. Output from the second I.F. amplifier passes from the plate circuit of V-505, through the third I.F. transformer T-506, and is applied to the second detector and noise limiter tube V-506, and to the A.G.C. diode V-507 through coupling capacitor C-556.

c. THE SECOND DETECTOR AND NOISE LIMITER CIRCUITS (V-506). (See Figure 2-10).

The double diode 6H6, V-506, performs the double function of action as a second detector for incoming signals from the I.F. amplifier (and also for the output from the beat frequency oscillator) and as a noise limiter for sharp noise pulses (such as ignition interference) for which the amplitude is greatly in excess of the signal intelligence. When the "NOISE LIMITER" switch S-504 on the front panel is in the "OFF" position, as in Figure 2-10, the second diode of the 6H6 is cut out of the circuit and the first diode functions as a conventional diode detector, with R-526 and R-527 as diode load resistors. If desired, detector current through these resistors may be measured at the terminals E-520 on the rear of the chassis by removing the jumper, and inserting a microammeter into the circuit. When the "NOISE LIMITER" switch S-504, is in the "ON" posi-

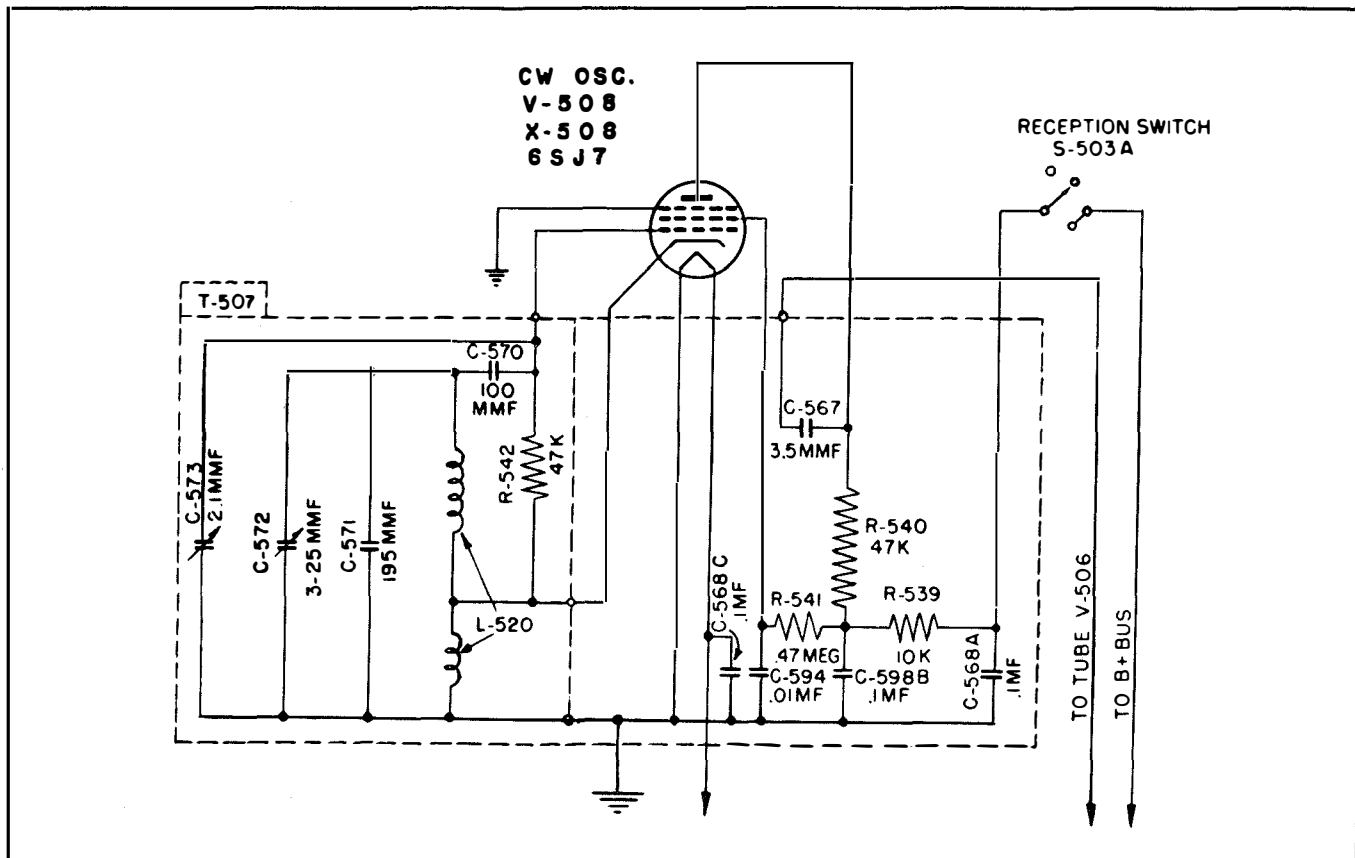

Figure 2-11. Beat Frequency Oscillator Circuit

tion, the second diode of V-506 is connected in series with the audio output of the detector. Under normal conditions of reception, this diode is in a conducting state because the negative voltage applied to its cathode through the resistance-capacitance network, R-528, C-561 and R-549, is greater than the negative voltage applied to its plate. The voltage at the cathode of the diode can not change rapidly because of the time required to charge the capacitor C-561 through the resistor R-528. The voltage at the plate of the diode, however, changes as rapidly as the signal modulation. When noise pulses of high amplitude and short duration (such as ignition noise), are received along with the audio signal, the plate of the diode becomes momentarily more negative than the cathode. This renders the diode non-conducting for the duration of the noise pulse, preventing the disturbance from reaching the audio amplifier. Since the diode is cut off for only a few microseconds, the "holes" punched in the audio output are not noticeable.

d. THE BEAT FREQUENCY OSCILLATOR CIRCUIT (V-508). (See Figure 2-11).

The beat frequency oscillator circuit is an electron-coupled oscillator, employing a type 6SJ7 electron tube, V-508, which provides an output signal of 1256 kilocycles frequency. This locally generated signal combines with the 1255 kilocycle output of the I.F. amplifier at the second detector V-506 to produce a 1000 cycle beat note. The tuned circuit of the beat frequency oscillator (B.F.O.) consists of the inductance L-520 and capacitors C-571, C-572 and C-573, all located in transformer assembly T-507. Capacitor C-573 provides a small change in the oscillator frequency (1255 to 1260 kilocycles). The rotor shaft of this capacitor terminates in the front panel "BEAT NOTE" control. Output from the B.F.O. is coupled to the second detector V-506 through capacitors C-567 and C-556. Switch S-503A (marked "RECEPTION" on the front panel) applies plate and screen voltage to oscillator tube V-508 when in the "CW" and "OL" positions. When this switch is in the "AGC" and "MOD" positions, the B.F.O. is inoperative.

e. THE AUTOMATIC GAIN CONTROL CIRCUIT (V-507). (See Figure 2-6).

A double-diode, type 6H6 electron tube, V-507, (Figure 7-1) and associated resistors and capacitors (R-519, R-523, R-573, R-531, R-532, R-545, R-575, C-559, C-581 and C-582), provide automatic gain control (A.G.C.) to the R.F. amplifier tube, V-501, the first I.F. amplifier tube, V-504, and the first A.F. amplifier V-509. I.F. input to the A.G.C. tube V-507 passes through the coupling capacitor C-556 from the third I.F. transformer T-506. In the "AGC" position of the "RECEPTION" switch S-503, the A.G.C. circuit applies full A.G.C. voltage to all controlled tubes. In the "MOD", "CW"

and "OL" positions the positive voltage (delay bias) applied to the cathode of the diode V-507, through resistor R-545, is effectively doubled by shunting this resistor with R-575, and the A.G.C. voltage developed by V-507 is decreased by grounding one end of resistor R-519 and the junction of resistors R-531 and R-573, thereby decreasing the diode load resistance. This completely removes the A.G.C. voltage from the converter V-502 and the first audio amplifier V-509. However, for very strong signals, the circuit still operates to bias the R.F. amplifier V-501 and the first I.F. amplifier V-504.

f. THE FIRST AND SECOND AUDIO AMPLIFIER CIRCUITS (V-509). (See Figures 2-6 and 2-12).

The first audio amplifier is composed of the type 6SK7 electron tube V-509 and its associated resistors and capacitors (R-503, R-530, R-533B, R-538, R-550, R-562, R-571, C-550A, C-550B, C-557, C-558A and C-576). The plate circuit of V-509 contains a low pass filter consisting of the tuned reactive elements L-521 and L-522, and capacitors C-563, C-564, and C-565. This filter attenuates audio frequencies above 3500 cycles per second (Figure 2-12).

The second audio amplifier comprises the type 6SK7 electron tube V-510 and its associated components. When switch S-503A is in its extreme clock-wise position ("RECEPTION" control on "OL"), output limiting is accomplished by means of the potentiometer R-533A and resistor R-569. Potentiometer R-533A, when retarded, lowers the plate and screen voltages of the tube V-510. The inverse feedback circuit (R-567, C-562, and C-595), between electron tubes V-510 and V-511, provides uniform frequency response of the receiver output over a range of 100 to 3000 cycles per second, and affords good output regulation when switching from one to two sets of headphones or vice versa.

g. THE AUDIO OUTPUT CIRCUIT (V-511). (See Figure 2-12):

The audio output stage consists of a type 6V6-GT electron tube, V-511, and associated components. The output of this stage is coupled through the transformer T-508 to the phones circuit. This transformer provides D.C. isolation of these circuits. From the secondary of the output transformer T-508, the signal passes to terminal E of receptacle P-504 (Figure 2-13), then through the interconnecting cable W-101 to the Rectifier, Power-Amplifier Unit, entering at terminal E of receptacle J-903 and passing to the primary of the input transformer T-902 (Figure 2-14), and to the phone jacks J-904 and J-905. The signal for the phone jack J-503, on the panel of the radio receiver, comes directly from the secondary of the output transformer, T-508. The signal may be received by headphones at these jacks, (J-503, J-904 and J-905)

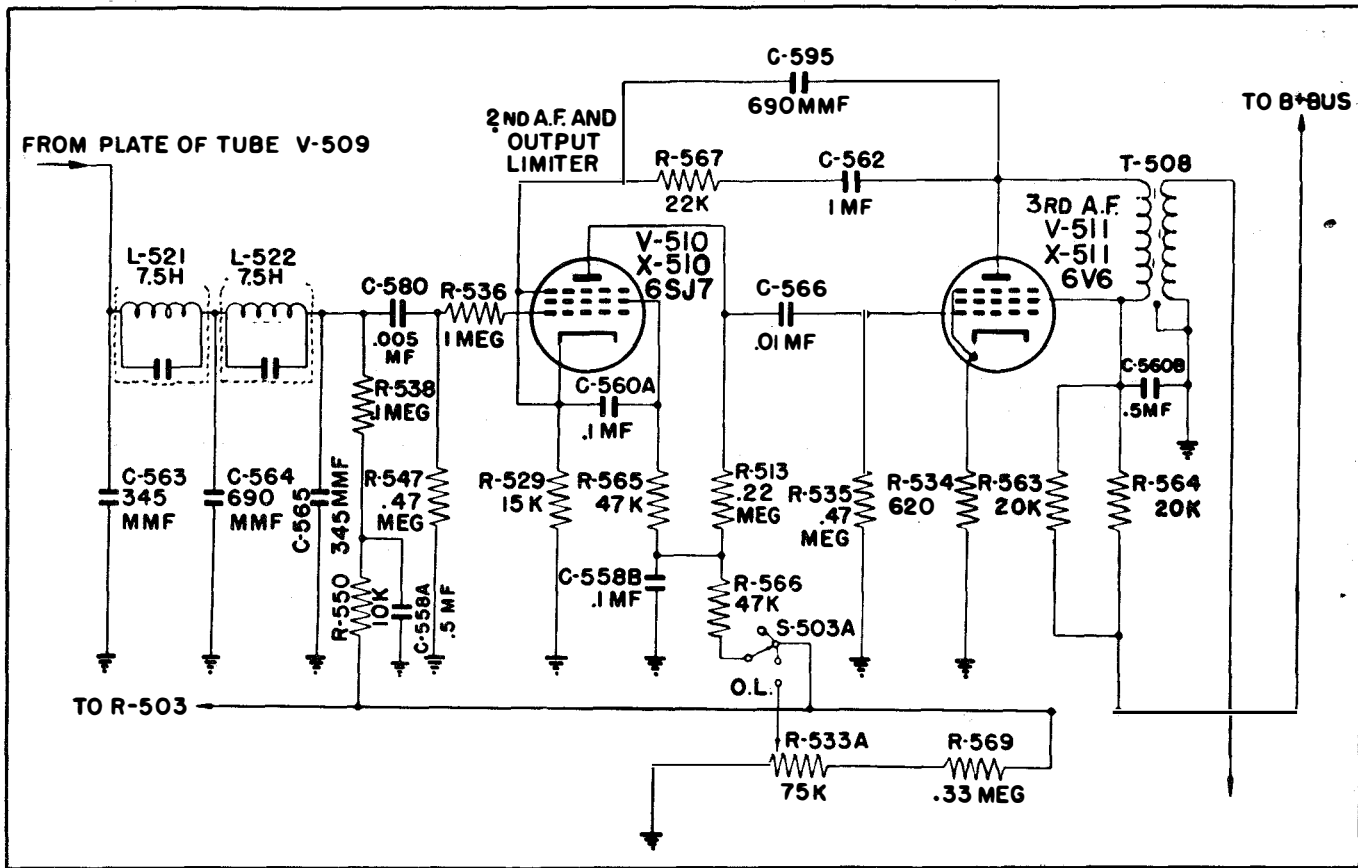

Figure 2-12. Audio Filter and Receiver Output

4. CIRCUIT ANALYSIS OF RECEIVER, RECTIFIER, POWER-AMPLIFIER UNIT.

a. THE PHONES CIRCUIT.—(See Figures 2-13 and 2-14).

The Rectifier, Power Amplifier unit has two headphone jacks, J-904 and J-905, each on the panel. These are connected through receptacles P-504 of the radio receiver and J-903 of the Rectifier, Power-Amplifier Unit through the cable W-101 to the "PHONES" jack on the Receiver panel. (Compare Figure 2-13 with Figures 7-18 and 7-19). Each of these phone jacks receives the signal from the radio receiver audio output transformer T-508. The "HEADPHONE LEVEL CONTROL" on the Rectifier Unit panel regulates the audio output of the phones at this panel by means of the potentiometer R-905 in series with the fixed resistor R-906. The 330 ohm resistor R-906 maintains the output at the phone jack J-503 and the loudspeaker jack J-902 at a substantially constant level regardless of the setting of the control potentiometer R-905 or of the employment of either one or two headphone sets.

b. THE PUSH-PULL AMPLIFIER. (See Figures 2-14 and 7-2).

The push-pull amplifier comprises two 6V6-GT tubes, V-902 and V-903. It provides 8 watts output with less

than 10 percent distortion, and approximately 10 watts maximum output. A balanced, electrostatically shielded output transformer T-903 delivers the output power into a 600-ohm load. An input transformer T-902 which has a turns ratio of 1 to 1½, drives the grids of the tubes. A series resistance-capacitance network, R-903 and C-906, connected from plate to plate of the tubes, V-902 and V-903, limits the high frequency response of the amplifier so that the overall response, receiver through amplifier, is within the required limits. Use of the phones circuit (Paragraph 4a), connected across the primary of the input transformer T-902, has negligible effect on the output of the push-pull amplifier.

c. THE POWER SUPPLY CIRCUIT. (See Figure 2-15).

The power supply circuit includes the power transformer T-901, the full-wave high vacuum type 5U4G rectifier tube V-901, and associated components. The power transformer T-901 is energized through the line input receptacle J-901. A pair of 2-ampere fuses, F-901 and F-902, are located in the primary circuit of the power transformer to protect it against overload. The "POWER ON-OFF" switch S-901 is also located in the primary circuit of this transformer. To filter line noises from the equipment, each side of the transformer pri-

mary is by-passed to ground through a capacitor. The two capacitors, C-901A and C-901B, form a dual unit each rated at 0.1 microfarad, 400 V.D.C.

The first filter section consists of a 5-henry input choke L-901, tuned to 120 cycles by the 0.35 microfarad, 400-volt capacitor C-902, followed by the 4.0 microfarad, 600-volt capacitor C-905. The second filter section consists of the 5-henry choke L-902 and the 4.0 microfarad, 600-volt capacitor C-902. The third section consists of the 700-ohm resistor R-902 and the 4 microfarad, 600-

volt capacitor C-903. The 10,000-ohm bleeder resistor, R-901, completes the circuit. The power supply furnishes 265 volts d.c. to the push-pull amplifier plates and screens, and 215 volts d.c. to the plates and screens of the receiver tubes. In addition, a separate power transformer secondary supplies 6.3 volts a.c. to lamps I-501, I-503, and I-901, and to the heaters of all tubes in the equipment except the 5U4G, V-901, rectifier. The rectifier tube, (V-901), obtains its filament power from a separate 5 volt a.c. power transformer secondary.

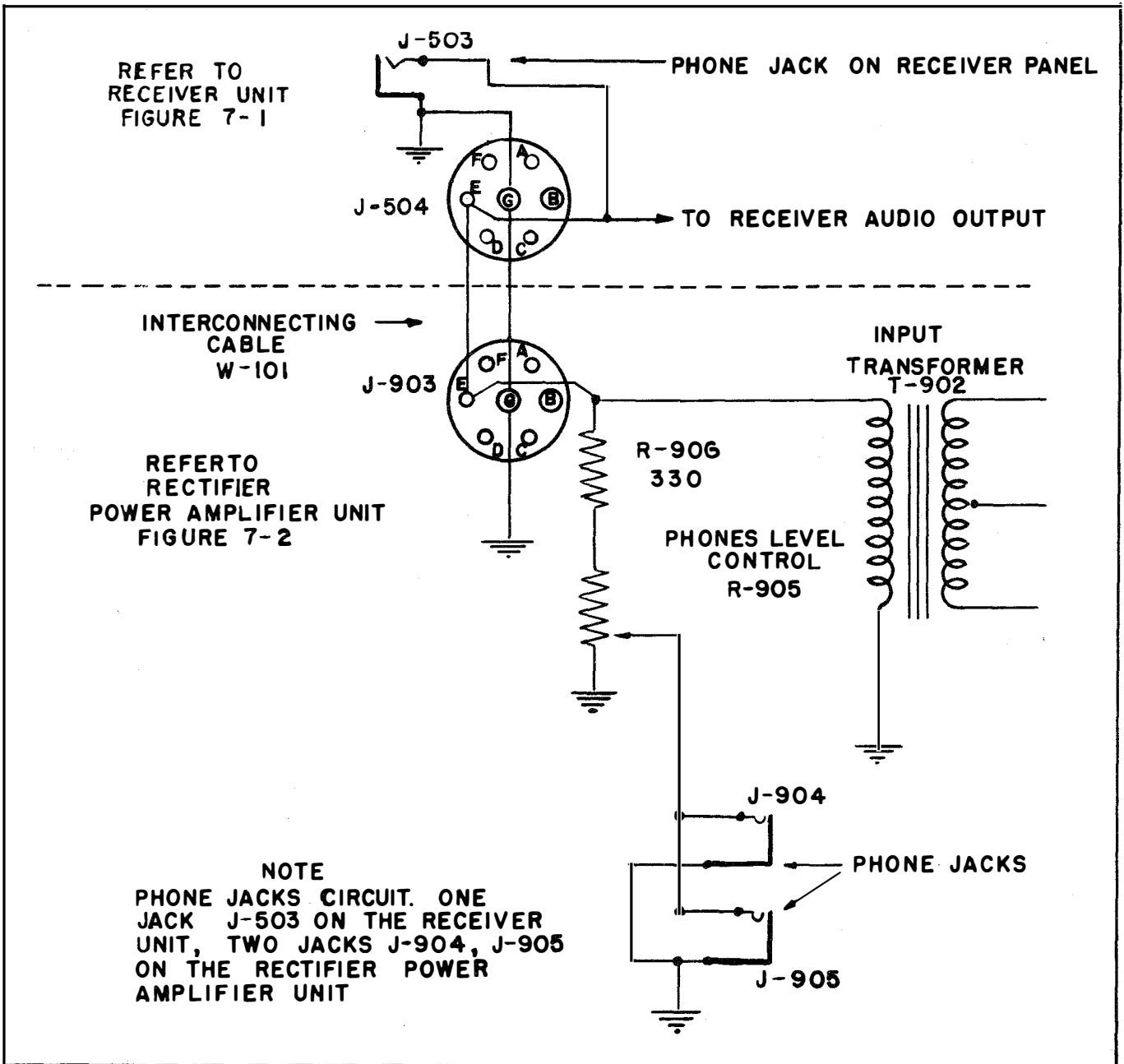

Figure 2-13. Phone Jacks Circuits

2-12

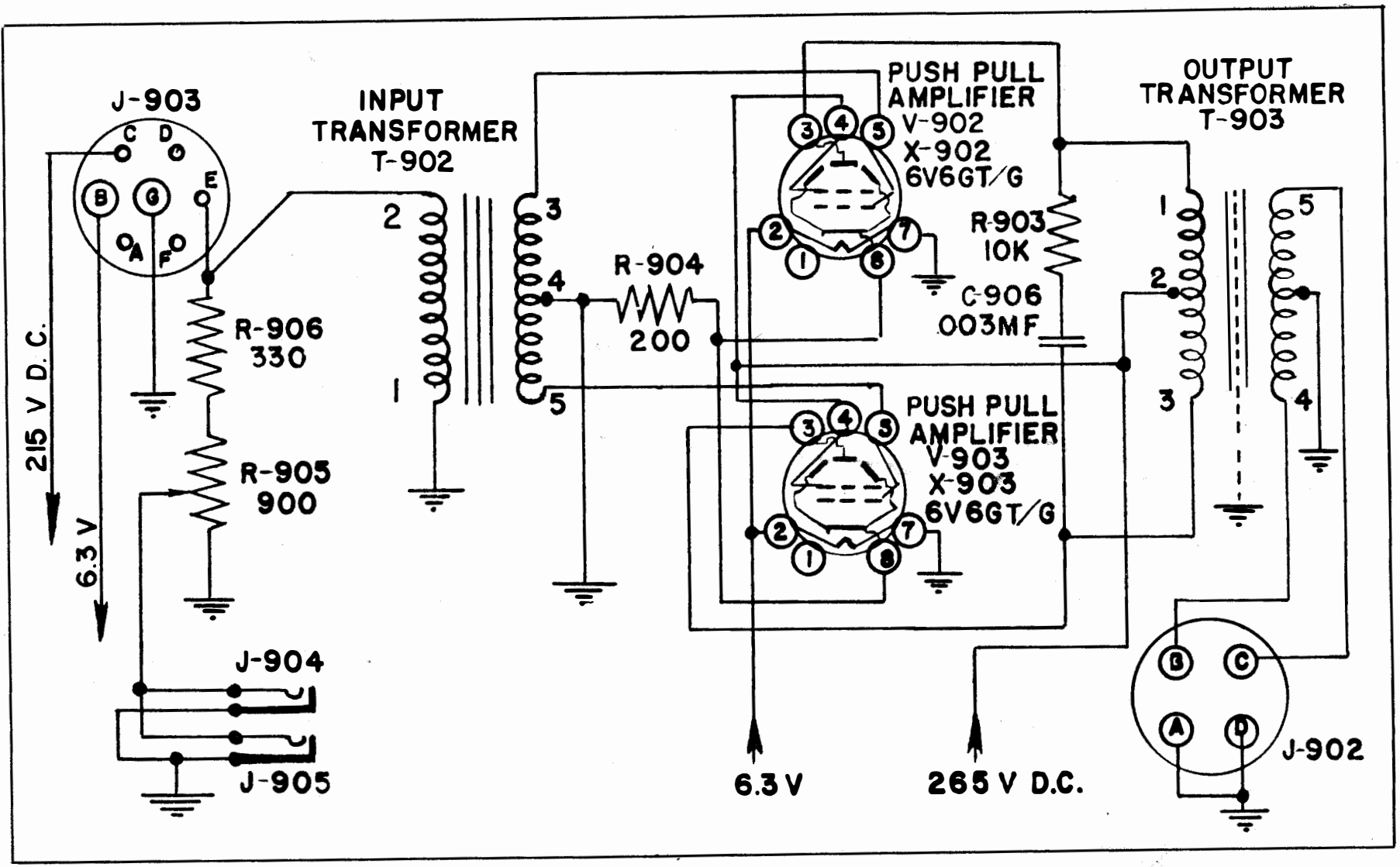

Figure 2-14. Push-Pull Amplifier Circuits

ORIGINAL

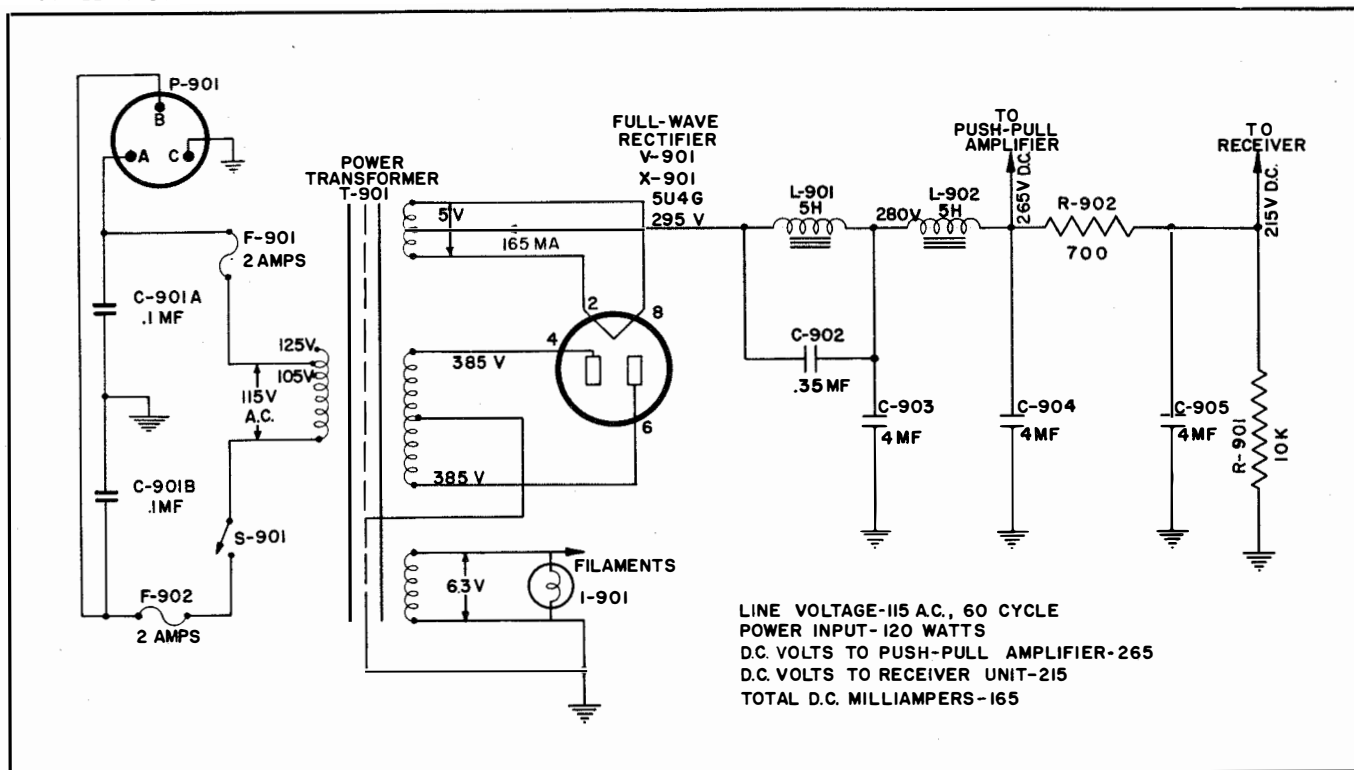

Figure 2-15. Power Supply and Filter Circuits

SECTION 3 INSTALLATION

1. UNPACKING THE EQUIPMENT.

The RBS-3 equipment is packed in cardboard cartons, which are crated in a wooden shipping box. (Refer to section 1, paragraph 3.) To unpack the equipment, proceed as follows:

Step *a.* Carefully open the wooden shipping box.

Step *b.* Remove the Radio Receiver and Rectifier Power-Amplifier Units from their cardboard cartons.

Step *c.* Examine the panel controls and see that they are held firmly in place and are in good condition.

Step *d.* Inspect the equipment for dents which may have injured the units and result in faulty operation.

Note

Strictly observe the following notation wherever stamped on cartons, "Packed with dehydrant. Do not open until ready for use."

2. LOCATING THE EQUIPMENT.

The design of the RBS-3 equipment allows only for mounting on a standard Navy radio operating table.

Exact location will depend upon the available space and the arrangement of associated equipment.

3. MOUNTING THE RBS-3 EQUIPMENT.

The RBS-3 equipment is designed for mounting on a standard Navy radio operating table.

a. MOUNTING RECTIFIER POWER-AMPLIFIER UNIT. (See Figure 1-3).

(1) Using mounting plate A-901 of the Rectifier Power-Amplifier Unit as a template, drill four 13/32 inch holds through the table top.

(2) Bolt the Rectifier, Power-Amplifier Unit in position beneath the table top, using 3/8 bolts of suitable length. A plain washer is used under the head of the bolt. A plain washer and a lock washer are used under the nut.

b. MOUNTING RADIO RECEIVER. (See Figures 1-2 and 3-3).

(1) Using Mounting plate A-505 of the radio receiver as a template, drill four 13/32-inch holes through the table top or shelf on which the receiver will be mounted.

3 Section
Paragraph 3b (2)

NAVSHIPS 91944
RBS-3

INSTALLATION

(2) Place the receiver in position on the table (or shelf) and bolt the mounting plate to the table top, using 3/8 bolts of suitable length.

(3) Connect right angle plug J-504 of the interconnecting cable and plug assembly W-101 to receptacle P-504 located on the back of the receiver. (See Figure 3-2).

(4) Connect plug P-903 on the free end of the cable to receptacle J-903 on the underside of the Rectifier Power-Amplifier Unit. (See Figure 3-4).

(5) Securely lock the coupling rings on plugs J-504 and P-903 to insure positive electrical bonding.

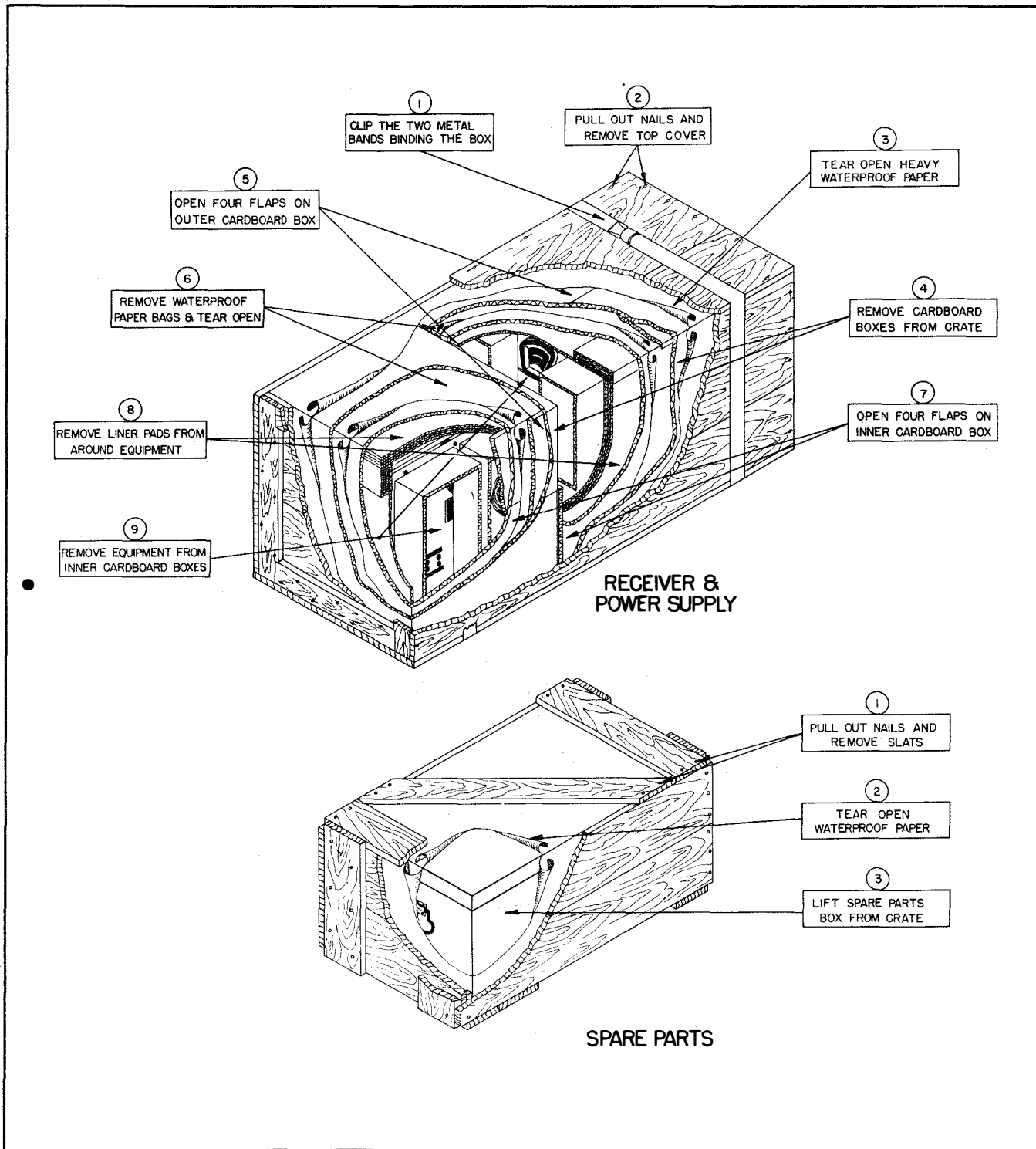

Figure 3-1. Packaging Drawing for RBS-3 Equipment

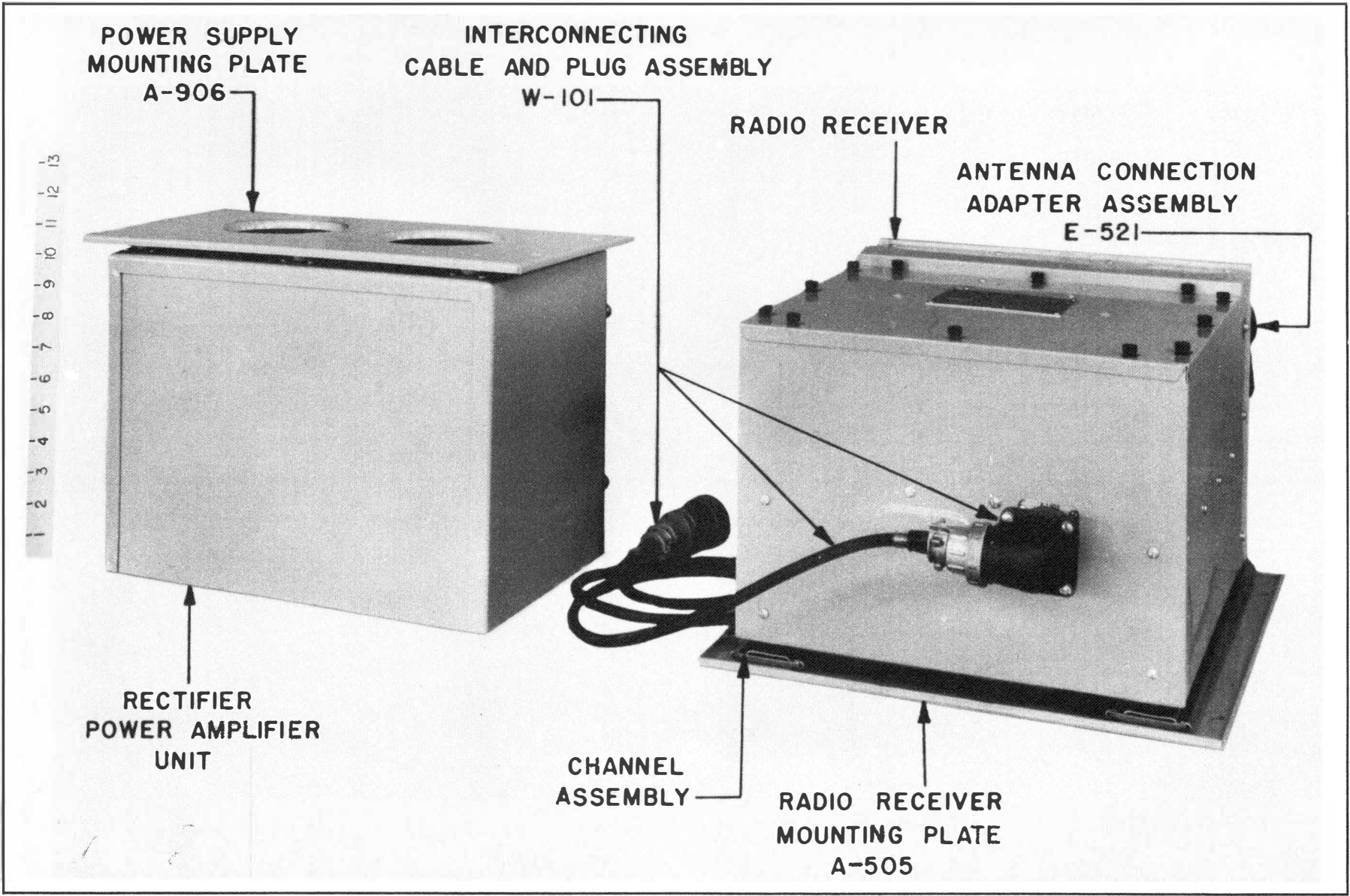

Figure 3-2. Radio Receiving Equipment Navy Model RBS-3, Right Rear View

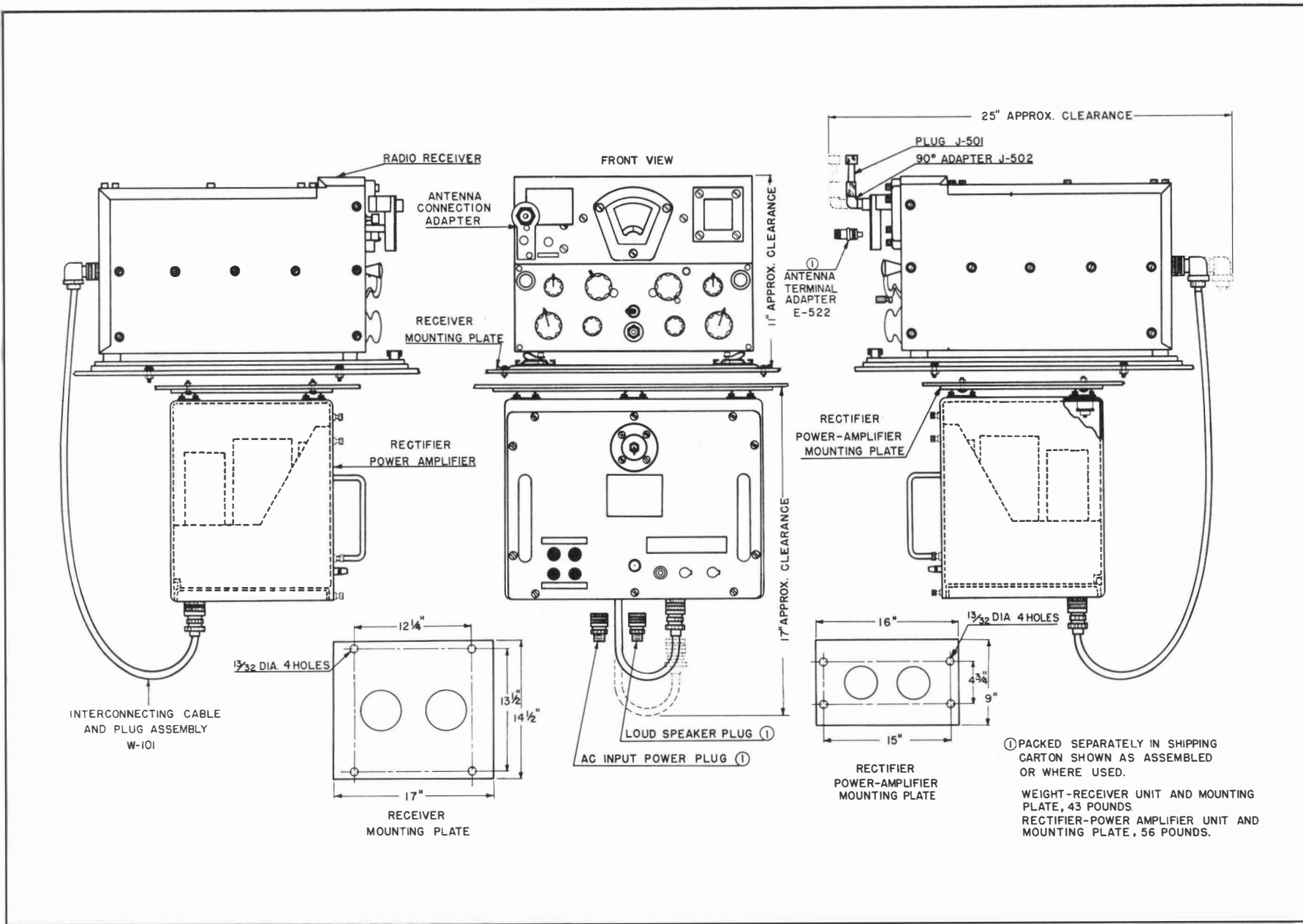

Figure 3-3. Radio Receiving Equipment Navy Model RBS-3, General Assembly

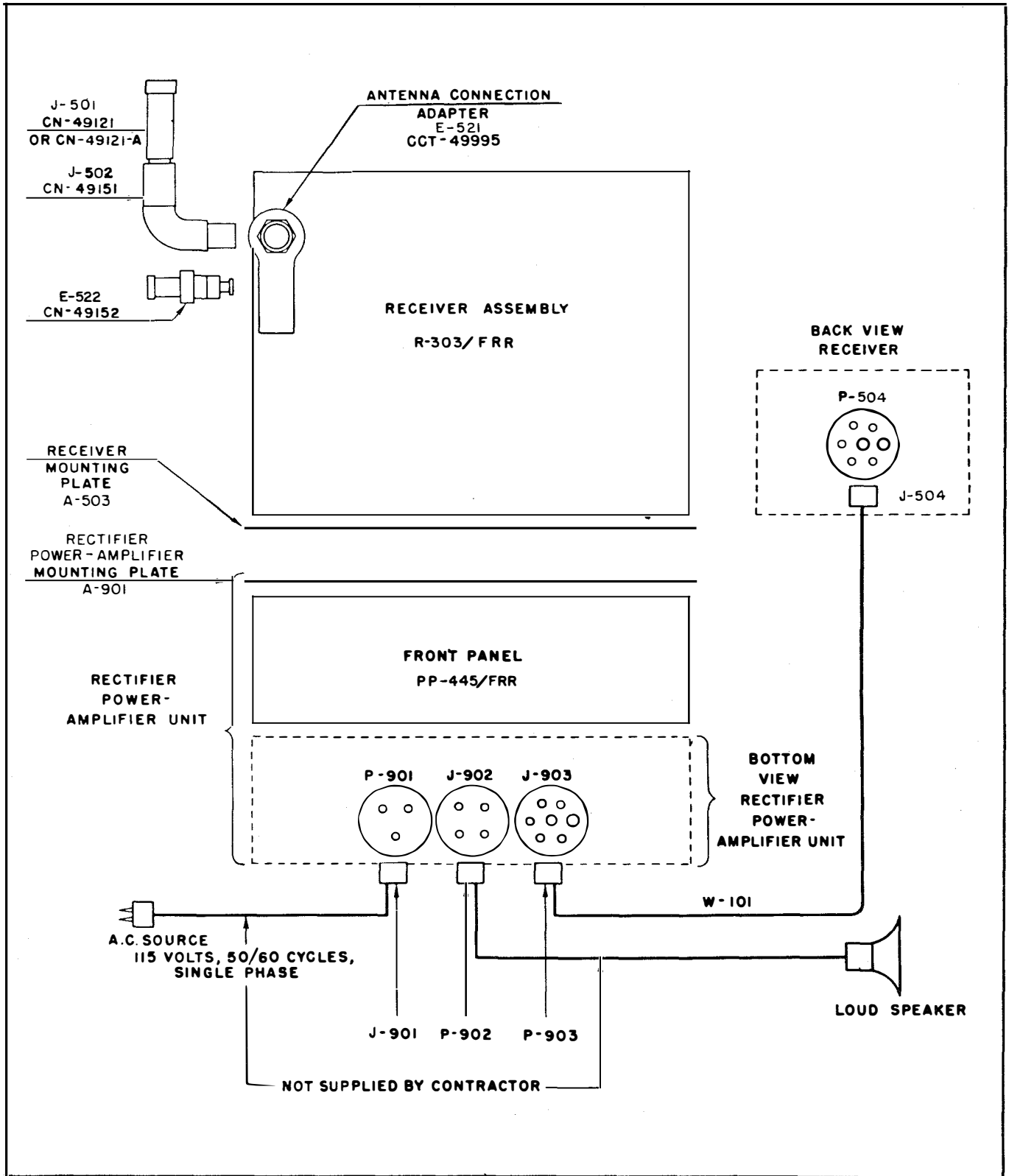
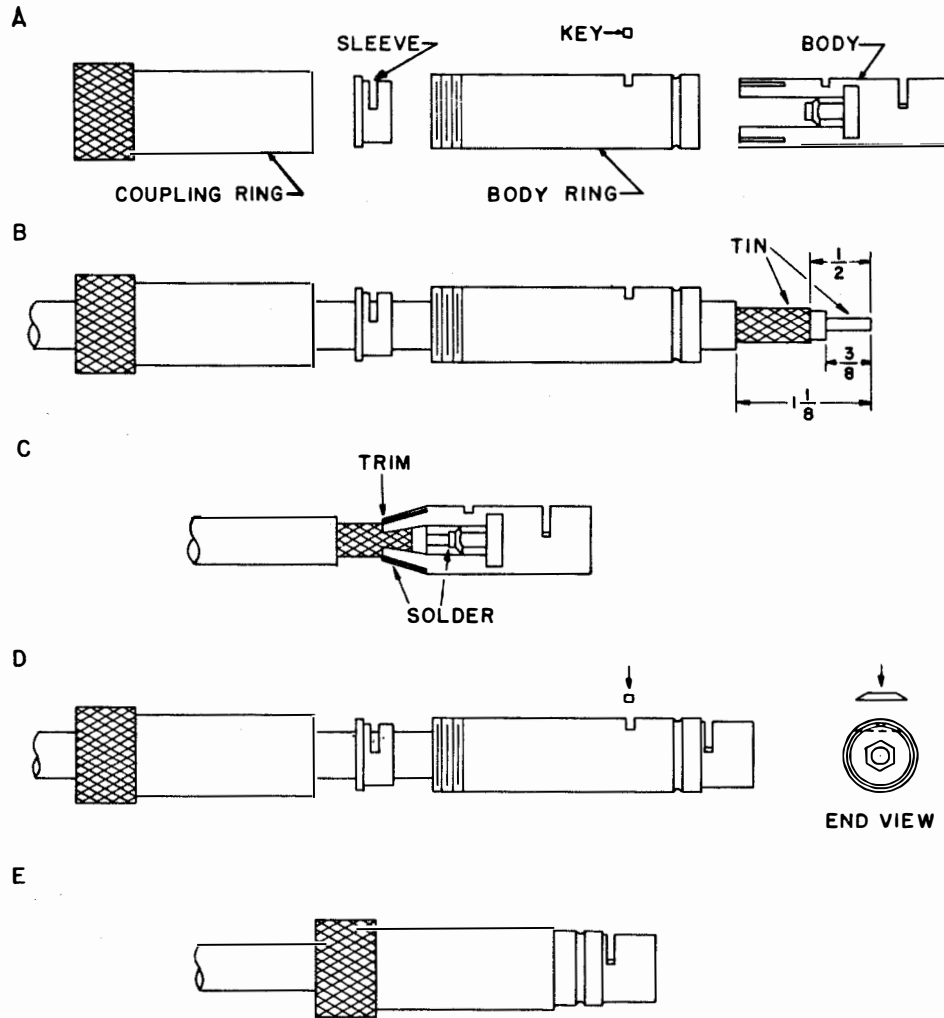

Figure 3-4. Radio Receiving Equipment Navy Model RBS-3, Interconnection Diagram



(A) TO DISASSEMBLE CO-AXIAL ANTENNA CONNECTOR J-501 (NAVY TYPE 49121) - UNSCREW COUPLING RING FROM BODY RING AND SLEEVE WILL DROP OUT - REMOVE KEY FROM BODY RING AND SLIP BODY OUT OF BODY RING.

(B) SLIDE COUPLING RING, SLEEVE AND BODY RING OVER CABLE - CUT THE OUTER JACKET OF THE CABLE $1 \frac{1}{8}$ " FROM END - BE CAREFUL NOT TO NICK THE COPPER BRAID UNDERNEATH - CUT THE COPPER BRAID $\frac{1}{2}$ " FROM END AND THE INNER INSULATION $\frac{3}{8}$ " FROM END - TIN OUTER BRAID AND INNER CONDUCTOR - BE CAREFUL NOT TO OVERHEAT INNER INSULATION.

(C) SLIP INNER CONDUCTOR INTO THE CENTER CONTACTOR AS FAR AS IT WILL GO - CAREFULLY BEND THE SLOTTED FINNS ON BODY TOWARD THE CENTER UNTIL THEY JUST TOUCH THE BRAID - SOLDER THE FINNS TO THE BRAID ALL AROUND AND SOLDER THE INNER CONDUCTOR TO THE INNER CONTACTOR. TRIM EXCESS SOLDER FROM AROUND BODY.

(D) SLIDE BODY RING AROUND BODY UNTIL THE SLOTS IN EACH LINE UP - INSERT KEY IN SLOT SO THAT IT DOES NOT EXTEND ABOVE BODY RING.

(E) SLIDE COUPLING RING AND SLEEVE UP AND SCREW COUPLING RING TO BODY RING.

Figure 3-5. Installation of Connector on Coaxial Antenna Cable

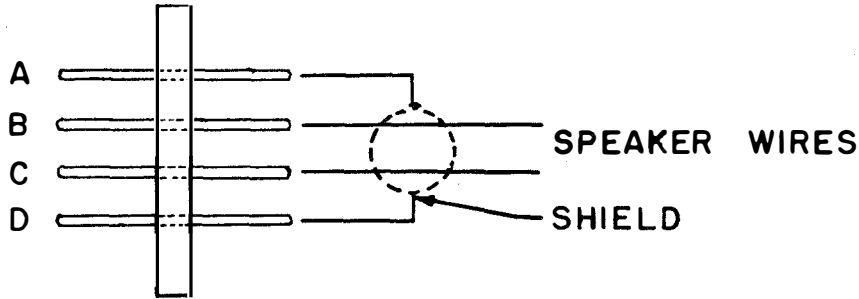

1. SOLDER SPEAKER WIRES TO TERMINALS B & C (MAKE SURE THAT NEITHER OF THESE WIRES ARE GROUND.)
2. SOLDER SHIELD TO EITHER TERMINAL A OR D OR BOTH.

Figure 3-6. Installation Diagram for Speaker Cable Connector, P-902

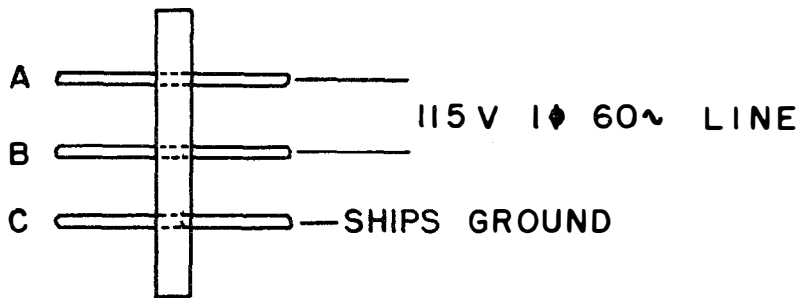

1. SOLDER LINE WIRE TO TERMINALS A & B.
2. SOLDER A GROUND TO TERMINAL C.

Figure 3-7. Installation Diagram for A.C. Power Cable Connector, J-901

4. CABLING CONNECTIONS FOR RBS-3.

a. RADIO RECEIVER TO RECTIFIER POWER-AMPLIFIER UNIT CONNECTIONS.

The attachment of interconnecting cable W-101 is described in paragraph 3b(3) of this section.

b. ANTENNA CONNECTIONS.

(1) SINGLE WIRE LEAD-IN.

(a) Connect antenna terminal adapter E-522 to the lead-in wire. (See Figures 1-2 and 3-3).

(b) Plug adapter E-522 into antenna connection adapter assembly E-521 mounted on the front panel of the receiver. Check for tight contact and good electrical bonding. The 90° adapter J-902 may be used between antenna terminal adapter E-522 and antenna connection adapter assembly E-521 if a right-angle connection is required.

(2) COAXIAL CABLE LEAD-IN. (See Figure 3-5).

(a) Connect antenna plug J-501 to the coaxial cable.

(b) Connect antenna plug J-501 to antenna connection adapter assembly E-521 located on the front panel of the receiver. Use the 90° adapter between J-501 and E-521 if a right-angle connection is required. Check for tight contact and good electrical bonding. (See Figures 3-5, 1-1, and 1-2).

c. LOUDSPEAKER CABLE CONNECTION.

The loudspeaker and loudspeaker cable are not supplied with the equipment.

(1) Attach plug P-902, which is supplied with the equipment, to the loudspeaker cable. (See Figure 3-6).

(2) Insert plug P-902 into the center receptacle (J-902) on the Rectifier Power-Amplifier Unit. (See Figure 1-7).

(3) Lock plug P-902 in place with the coupling ring provided.

Note

When the loudspeaker cable is not attached, the receptacle should be covered by the metal cap chained to the chassis to exclude moisture from the equipment. (See Figure 1-7).

d. A.C. INPUT POWER CABLE CONNECTION.

The A.C. Input Power Cable is not supplied with the equipment.

(1) Locate the nearest 115 volt 50/60 cycle A.C. power source.

(2) Use a length of power cable (Navy type MCOS-2) long enough to run from the equipment to the power source.

(3) Attach plug J-901, supplied with the equipment, to the power cable. (See Figure 3-7).

(4) Insert J-901 into P-901 located on the bottom of the Rectifier Power Amplifier chassis and lock it securely in place.

(5) Connect the free end of the power cable to the power source, using a standard Navy type connector.

**SECTION 4
OPERATION**

I. PANEL MARKINGS AND CONTROLS.

a. GENERAL.—All the controls necessary to operate the RBS-3 Radio Receiving Equipment are located on the front panels of the Radio Receiver and the Rectifier Power-Amplifier Unit. Each control knob governs an electric circuit designed to perform a function which is identified by an inscription above or around the control knob.

b. PANEL MARKINGS AND CONTROLS ON THE RECTIFIER POWER-AMPLIFIER UNIT.

(1) "Power, ON-OFF".—Power to the receiver is controlled by the "Power, ON-OFF" switch located on the Rectifier POWER-AMPLIFIER UNIT. With this switch in the "ON" position, power from the A.C. line is supplied to the Radio Receiver and the Rectifier

Power-Amplifier Unit. In the "OFF" position, the power is completely cut off from the entire equipment. (See Figure 1-3).

(2) "HEAD PHONE LEVEL CONTROL".—The "HEAD PHONE LEVEL CONTROL", which is adjusted by a slotted-head screw, provides a means of maintaining the desired output level to the headphones plugged into the Rectifier Power-Amplifier Unit. The screw head is located underneath the chain-held cap. Maximum output is obtained by turning the screw head to the extreme clockwise position.

(3) "F-901 FUSE" and "F-902 FUSE".—The two 2-ampere cartridge type fuses used in the primary circuit of the power transformer are mounted on the front panel behind the two extractor-post fuse-holder caps marked "F-901 FUSE" and "F-902 FUSE".

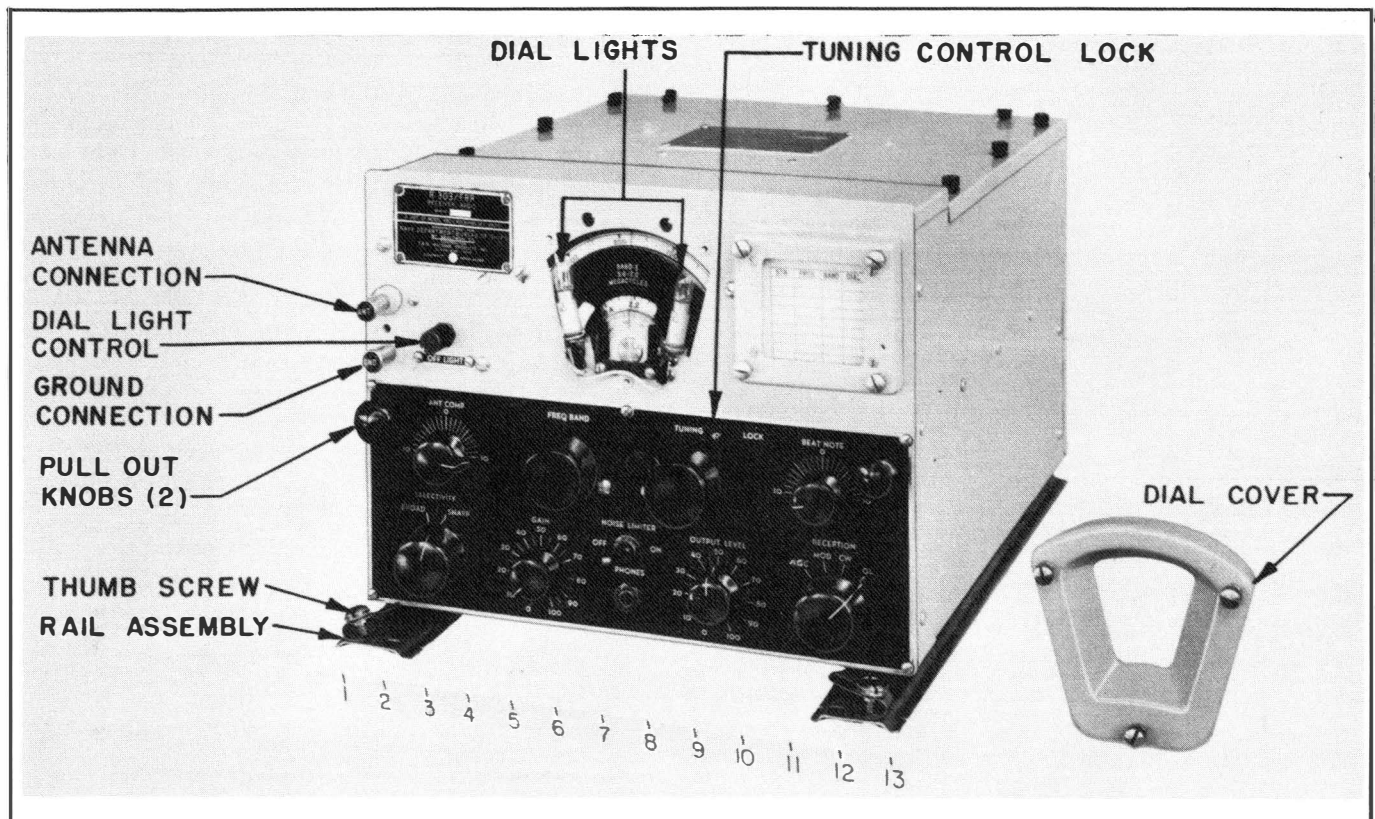

Figure 4-1. Radio Receiver Navy Type R-303/FRR, Left Front View

(4) (PHONE).—The headphone jacks are protected by hinged covers.

c. PANEL MARKINGS AND CONTROLS ON THE RADIO RECEIVER.

(1) "SELECTIVITY." — The "SELECTIVITY" control is a two position switch controlling the degree of coupling between two stages of the receiver intermediate frequency amplifier circuits to produce "BROAD" or "SHARP" tuning. The "BROAD" position is primarily used for voice reception and the "SHARP" position is used for C.W. and M.C.W. reception.

(2) "GAIN".—The "GAIN" control is a potentiometer which controls the overall gain of the receiver. When the control is rotated in a clockwise position, the overall gain of the receiver is increased. This control is operative in all four positions of the "RECEPTION" control.

(3) "NOISE LIMITER." — The "NOISE LIMITER" control is a two position toggle switch which cuts the noise limiter tube in and out of the circuit. When encountering conditions of sharp peak interference, such as caused by static, key clicks, and other intermittent electrical disturbances, the "NOISE LIMITER" is switched on the "ON" position. The "NOISE LIMITER" control is operative in all four positions of the "RECEPTION" control.

(4) "OUTPUT LEVEL." — The "OUTPUT LEVEL" control is a dual potentiometer. The front section of the potentiometer controls the plate and screen voltages of the second audio frequency amplifier tube, and the rear section controls the signal input to the first audio frequency amplifier tube. The front section of the control is operative only on the "OL" position of the "RECEPTION" control and the rear section is operative on the remaining "AGC", "MOD" and "CW" positions. In both cases, the control serves to adjust the audio output volume of the receiver to the headphones.

(5) "RECEPTION".—The "RECEPTION" control may be set to the following positions:

(a) "AGC" (AUTOMATIC GAIN CONTROL).—The "AGC" position maintains a substantially constant receiver output when used normally for voice modulated reception. In this position, the beat frequency oscillator and output limiter circuits are inoperative.

(b) "MOD" (MODULATED).—The "MOD" position of the "RECEPTION" control is used for either voice or tone modulated reception. In this position, the automatic gain control, beat frequency oscillator, and output limiter circuits remain inoperative.

(c) "CW" (CONTINUOUS WAVE).—The "CW" position of the "RECEPTION" control applies voltage to the beat frequency oscillator for C.W. reception. In this position, the automatic gain control and the output limiter circuits are inoperative.

Paragraph 1c (5) (d)

RBS-3

(d) "OL" (OUTPUT LIMITER).—In the "OL" position of the "RECEPTION" control, the B.F.O. remains in the circuit for C.W. reception and the "OUTPUT LEVEL" control regulates the audio amplifier output. In this position the operator's ears are protected against strong signals due to nearby transmitters, or against excess audio output peaks when there is a wide variation in the strength of received signal. In this position the automatic gain control circuit is inoperative.

(6) "ANT COMP" (ANTENNA COMPENSATOR).—The "ANT COMP" control matches the receiver input to antennas varying in capacities from 80 to 500 micromicrofarads. After being adjusted for the antenna in use at one point near the high frequency end of each band, it requires no further adjustments when tuning to other frequencies within that band.

(7) "BEAT NOTE".—The complete range of the "BEAT NOTE" control provides for a maximum variation in frequency of the C.W. beat frequency oscillator of approximately 5000 cycles. The beat frequency oscillator (B.F.O.) is so adjusted that a beat note of 400 to 1600 cycles will be heard in the output of the receiver when the pointer of the control is set to zero and a signal is centered in the acceptance band of the receiver.

(8) "FREQ BAND" (FREQUENCY BAND).—The "FREQ BAND" control is used to select the desired

frequency band of the four bands available. The frequency reading for the band in use is visible through a slot in the masking plate giving the band number (Figure 4-2). For bands one and two, the frequency reading is found through the slot immediately below the band number on the masking plate. For bands three and four the reading is found through the slot immediately above the band number on the masking plate.

(9) "LOCK".—The "TUNING" control may be secured at any setting by rotating the tuning "LOCK" to the extreme clockwise position.

(10) "OFF-LIGHT".—The dial lights are at their brightest when the dial light dimmer control is at its extreme clockwise position. When rotated in a counterclockwise direction, the lights gradually become dimmer until they are completely extinguished at "OFF".

(11) "ANT" and "GND" (ANTENNA AND GROUND).—The "ANT" post is the antenna connection, and the "GND" post is for the ground.

(12) "TUNING".

(a) DESCRIPTION.—The "TUNING" control rotates the four gang tuning capacitor and the main and vernier tuning dials, visible through the dial escutcheon which also encloses the two dial lights, (Figures 4-1 and 4-2). Ten complete revolutions of the "TUNING" control are required to cover each frequency band.

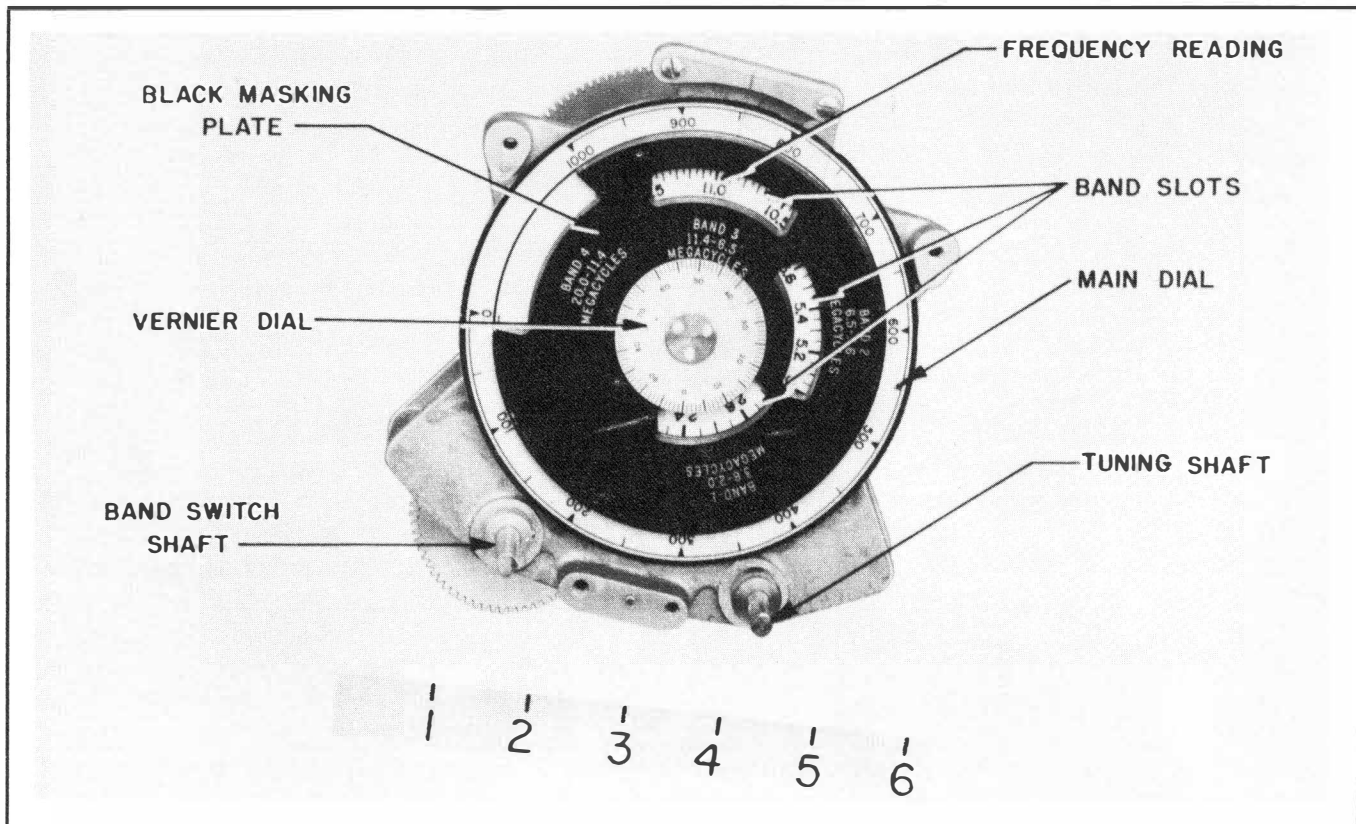

Figure 4-2. Tuning Dial Assembly, U-501, Front View

(b) **READING THE DIAL AND RECORDING DIAL SETTINGS.**—The frequency dial setting is read from two scales — the top main dial and the bottom vernier dial. The top main scale has a range from 0 to 1000, each scale division being 50. The bottom vernier scale has a range from 0 to 100. If the top main scale moves from 0 to 100, the bottom vernier scale will make one complete revolution, 0 to 100. The bottom vernier scale provides a more accurate reading of the dial setting than could be obtained on the main top scale. For each frequency band the dial setting values range from 0 to 1000. Calibration cards are provided for recording station information, frequency, band and dial settings. The cards are framed in a card holder secured to the panel by captive thumb screws.

1. ILLUSTRATION USING BAND ONE.—

When the red line dial indicator lies between 0 to 50 on the top scales and the vernier bottom scale reads 35, the reading is 35. When the red line indicator is between 250 and 300 and the vernier scale reads 78, the dial reading is 278. When the dial reading is 278, 2.4 megacycles can be read through the slot below the band number.

2. ILLUSTRATION USING BAND THREE.

—Set the dial on the top scale between 250 and 300, and the vernier scale to 73. The dial reading is now 273 and the frequency reading 7.75 megacycles.

2. PRELIMINARY ADJUSTMENTS.

a. **PURPOSE.**—Preliminary adjustments for each band selected, must be made to align the receiver input to the antenna used. No further antenna adjustments are required when tuning to other frequencies within that band.

b. PROCEDURE.

(1) Set the "POWER, ON-OFF" switch to the "ON" position.

(2) Plug the headphones into the receiver "PHONES" jack.

(3) Rotate the "OUTPUT LEVEL" control clockwise to 100.

(4) Rotate the "GAIN" control until noise is faintly audible.

(5) Set the "SELECTIVITY" control to either the "BROAD" or "SHARP" position.

(6) Set the "NOISE LIMITER" to the "OFF" position.

(7) Set the "BEAT NOTE" control to 0.

(8) Set the "RECEPTION" control to the "CW" position.

(9) Rotate the "FREQ BAND" control to the desired frequency band.

(10) Tune to the highest frequency end of the band as indicated on the masking plate.

(11) Adjust the "ANT COMP" control for maximum noise level in the headphones.

(12) To stop the equipment, set the "POWER, ON-OFF" switch to the "OFF" position.

3. NORMAL TUNING PROCEDURE.

a. C.W. (CONTINUOUS WAVE) RECEPTION.

(1) Set the "POWER, ON-OFF" switch to the "ON" position.

(2) Plug the headphones into the receiver "PHONES" jack.

(3) Set the "OUTPUT LEVEL" control to 100.

(4) Rotate the "GAIN" control until the noise level is faintly audible.

(5) Set the "SELECTIVITY" control to the "SHARP" position.

(6) Set the "NOISE LIMITER" switch to the "OFF" position.

(7) Set the "BEAT NOTE" control to 0.

(8) Set the "RECEPTION" control to the "CW" position.

(9) Rotate the "FREQ BAND" control to the desired frequency band.

(10) Set the "TUNING" control to the approximate desired frequency.

(11) Adjust the "TUNING" control until the desired signal approaches a zero beat. There should be no audible frequency difference.

(12) Turn the "TUNING" control from the zero beat position toward the lower dial frequencies until the desired signal is strongest in the headphones. When the headphone signal is approximately 1000 cycles, the dial frequency reading will be within 1 percent of the received frequency.

(13) Adjust the volume of the headphone signal by means of the "GAIN" control.

(14) To stop the equipment, set the "POWER, ON-OFF" switch to the "OFF" position.

b. M.C.W. (MODULATED CONTINUOUS WAVE) RECEPTION.

(1) Set the "POWER, ON-OFF" switch to the "ON" position.

(2) Plug the headphones into the receiver "PHONES" jack.

(3) Set the "OUTPUT LEVEL" control to 100.

(4) Rotate the "GAIN" control until the noise level is faintly audible.

(5) Set the "SELECTIVITY" control to the "SHARP" position.

(6) Set the "NOISE LIMITER" switch to the "OFF" position.

(7) Set the "BEAT NOTE" control to 0.

(8) Set the "RECEPTION" control to the "MOD" position.

(9) Rotate the "FREQ BAND" control to the desired frequency band.

(10) Using the "TUNING" control, tune the desired signal for maximum output in the headphones.

(11) Adjust the "GAIN" control to the headphone level desired.

c. VOICE RECEPTION.

(1) Set the "POWER, ON-OFF" switch to the "ON" position.

(2) Plug the headphones into the receiver "PHONES" jack.

(3) Set the "GAIN" control to 85.

(4) Rotate the "OUTPUT LEVEL" control until the noise level is faintly audible.

(5) Set the "SELECTIVITY" control to the "SHARP" position.

(6) Set the "NOISE LIMITER" switch to the "OFF" position.

(7) Set the "BEAT NOTE" control to 0.

(8) Set the "RECEPTION" control to the "CW" position.

(9) Rotate the "FREQ BAND" control to the desired frequency band.

(10) Set the "TUNING" control to the approximate desired frequency.

(11) Adjust the "TUNING" control until the desired signal approaches a zero beat. There should be no audible frequency difference.

(12) Turn the "TUNING" control from the zero beat position toward the lower dial frequencies until the desired signal is strongest in the headphones. When the headphone signal is approximately 1000 cycles, the dial frequency reading will be within 1 percent of the received frequency.

(13) Reset the "SELECTIVITY" control to the "BROAD" position to improve fidelity. Set the reception control to MCW.

(14) Use the "OUTPUT LEVEL" control to adjust the audio output.

d. HEADPHONE LEVEL CONTROL.—After the desired signal has been tuned in, remove the headphone from the receiver "PHONES" jack and plug it into one of the phone jacks marked "PH" in the Rectifier Power-Amplifier Unit. The output level of the headphones may be changed by turning in either a clockwise or counterclockwise direction the slotted head screw of the "HEADPHONE LEVEL CONTROL." The "HEADPHONE LEVEL CONTROL" is kept covered by a chain-secured cap.

e. SPEAKER "OUTPUT LEVEL" CONTROL.—When a speaker is used, the audio output level is adjusted by rotating the "OUTPUT LEVEL" control located on the Radio Receiver.

4. TUNING PROCEDURE WHEN INTERFERENCE IS PRESENT.

a. GENERAL.—Success in reading any type of signal under interference conditions depends upon the skill with which the adjustments (suggested in this section, paragraphs 2 and 3) are made. Careful analysis of all control actions will increase the ability to receive signals under interference conditions.

b. WEAK C.W. SIGNAL SEPARATED BY ONE OR TWO KILOCYCLES FROM A STRONG INTERFERING SIGNAL.

(1) PREFERRED METHOD.

(a) Set the "RECEPTION" control to the "CW" position.

(b) Set the "GAIN" control to 80 or 90.

(c) Tune the interfering signal to zero beat, either by the "TUNING" control or the "BEAT NOTE" control, or by a combination of both of these controls. Additional selectivity may be gained by tuning slightly to the side of the peak of the selectivity characteristic of the receiver. Under such conditions, although it may be impossible to secure a beat note of exactly 1000 cycles, a signal may be copied, which might otherwise be unreadable.

(d) It is possible to depart from the normal tuning procedure and tune the receiver toward the higher frequency end of the band from the zero beat position. This will often avoid an interfering signal located on the low frequency side of the desired signal although some loss of gain will result in the output of the receiver.

(e) If key clicks are heard because of a strong interfering signal, the effect may sometimes be decreased by setting the "NOISE LIMITER" switch to the "ON" position.

(2) OPTIONAL METHOD.

(a) Set the "RECEPTION" control to the "OL" position.

(b) Set the "GAIN" control to 80 or 90.

(c) Retard the "OUTPUT LEVEL" control until the interfering signal is at a comfortable level. This adjustment does not change the gain level of the desired signal; only the output resulting from the interfering signal is changed. The interfering signal may still be heard if the receiver is tuned near its frequency. Adjust the "TUNING" control and/or the "BEAT NOTE" control until the desired signal is received with the least interference.

c. STRONG C.W. SIGNAL SEPARATED BY ONE OR TWO KILOCYCLES FROM STRONG INTERFERING SIGNAL.

(1) Set the "SELECTIVITY" control to the "SHARP" position.

(2) Set the "GAIN" control to 80 or 90.

(3) Set the "RECEPTION" control to "C.W."

(4) Adjust the "OUTPUT LEVEL" control to a comfortable headphone level.

(5) Tune by the methods indicated in this section, paragraphs 4b (1) and (2) until a beat note is secured giving the beat response in the headphones. In this method the excitation from the beat frequency oscillator will limit the strong signal with considerably less audio frequency harmonic distortion than is produced when the "OL" (output limiter) position of the "RECEPTION" control is used.

d. M.C.W. SIGNAL WITH INTERFERENCE DUE TO SEVERE ATMOSPHERIC CONDITIONS.—When interference, due to severe atmosphere conditions (static), and the audio component of the M.C.W. signal are heard in the headphones or loudspeaker, better reception may be obtained if the receiver is operated with the "RECEPTION" control in the "CW" position (refer to this section, paragraphs 2, 3a, 4a, and 4b) and the receiver is tuned to beat with the carrier wave of the desired signal. Under these conditions, and if operating regulations permit, the receiving operator may request the transmitting station operator to change his type of transmission to C.W. to improve receiving conditions.

e. M.C.W. SIGNAL WITH INTERFERENCE DUE TO STRONGER UNDESIRE M.C.W. SIGNAL.—Where interference is caused by another and stronger M.C.W. signal on an adjacent channel, the condition can sometimes be minimized by tuning to the side of the desired signal opposite that of the interfering signal. This method will weaken the undesired signal to a greater degree than the desired signal. Then, by adjusting the "GAIN" control, the desired signal may be brought up to a satisfactory level in the headphones or loudspeaker. Optimum reception may also be effected

by adjusting the receiver for C.W. reception and using only the intermittent carrier wave of the transmitting station to provide a beat note in the receiver. The operator may then tune for the signal as previously described.

f. VOICE-MODULATED SIGNALS WITH INTERFERENCE DUE TO ANY TYPE OF UNDESIRE SIGNAL.—Interference caused by any type of undesired signal on an adjacent channel to a voice-modulated signal will cause a beat frequency note (heterodyne) to be heard in the headphones. The frequency of this note will be equal to the difference between the two frequencies. The audio frequency filter incorporated in the plate circuit of the first audio frequency stage of the receiver is designed to provide high attenuation of frequencies above 3500 cycles. Therefore, in most cases, only interference causing a heterodyne of less than 3500 cycles will affect reception.

(1) VOICE-MODULATED SIGNALS WITH HETERODYNE INTERFERENCE. To eliminate the undesired heterodynes, when receiving voice-modulated signals, adjust the "SELECTIVITY" control to the "SHARP" position, reducing the level of the desired signal. Although this will affect the quality of the modulated signal as it tends to eliminate high audio frequencies, it cannot be considered as a disadvantage when it permits more satisfactory reception.

(2) VOICE-MODULATED SIGNALS WITH INTERFERENCE FROM AN UNDESIRE SIGNAL ON AN ADJACENT CHANNEL.—When interference is caused by an undesired signal on an adjacent channel, it may be attenuated by slightly detuning the set with the "TUNING" control to the side of the signal opposite that on which the undesired signal is located. This will result in attenuation of both signals, but the interfering signal will be more attenuated than the desired one. Readjustment of the "GAIN" control may be necessary if this procedure is carried far enough to produce a drop in the level of the signal in the headphones. Although the audio components of the desired signal will be distorted, it permits the desired signal to be understood when it might otherwise be lost.

(3) VOICE-MODULATED SIGNALS WITH INTERFERENCE FROM ANOTHER VOICE-MODULATED SIGNAL.—Interference can be caused by another strong voice-modulated signal on an adjacent channel, even though the fundamental frequency of the undesired signal does not itself cause interference. Modulation peaks may cause side band "splatter" which affects reception of the desired signal. This effect is heard in the headphones as a harsh, scratchy, raspy sound. It may be overcome by applying the tuning methods outlined in this section, paragraphs 4f (1) (2).

SECTION 5 OPERATOR'S MAINTENANCE

I. INTRODUCTION.

This section contains information to aid the operator in maintaining the equipment in condition for peak performance efficiency. It includes routine check charts and additional information concerning emergency maintenance.

2. ROUTINE INSPECTION AND ROUTINE CHECK CHART.

Note

The attention of maintenance personnel is invited to the requirements of Chapter 67 or Chapter 68 of the "Bureau of Ships Manual" in the latest edition.

The tests and checks given in Table 5-1 should be made every day or after every eight hours of continuous operation.

TABLE 5-1. ROUTINE CHECK CHART

<i>What to Check</i>	<i>How to Check</i>	<i>What to do and Precautions</i>
	<p>Visually check the mountings of the units for looseness and corrosion. A type of probe may be useful.</p>	<p>Tighten any loose mounting and remove all corrosion.</p>
	<p>Check the mechanical and electrical condition of all exposed cables and plugs.</p>	<p>Make all connections tight. Replace defective wires or plugs.</p>
	<p>Check the ferrules of the two fuses mounted on the front panel of the rectifier, power amplifier unit for corrosion.</p>	<p>Clean off corrosion with fine crocus cloth if necessary. See that the two spare fuse holders contain good fuses.</p>
	<p>Inspect all exposed surfaces for traces of moisture and corrosion.</p>	<p>Clean and dry all exposed surfaces, removing all traces of moisture. To protect the finish of the nameplates from the action of saltwater, apply a small amount of light oil with a soft cloth.</p>

TABLE S-1. ROUTINE CHECK CHART—CONTINUED

<i>What to Check</i>	<i>How to Check</i>	<i>What to do and Precautions</i>
	Turn on receiver and check pilot and dial lights. Turn the "RECEPTION" CONTROL to "CW", the "OUTPUT LEVEL" control to 100, and the "GAIN" control to approx. 90; check for reception on all bands.	Replace defective bulbs. If receiver fails to function, have a qualified technician check the sensitivity of the receiver as directed in the corrective maintenance section.

3. EMERGENCY MAINTENANCE.

a. NOTICE TO OPERATORS.—Operators shall not perform any of the following emergency maintenance procedures without proper authorization.

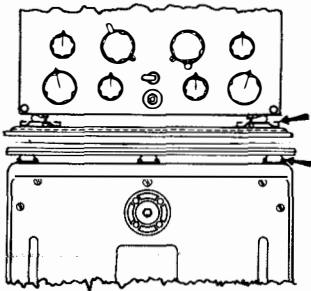
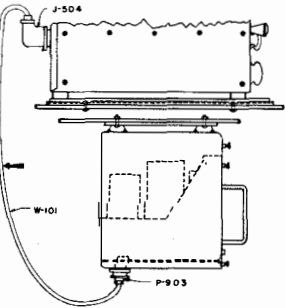
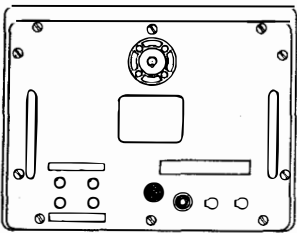
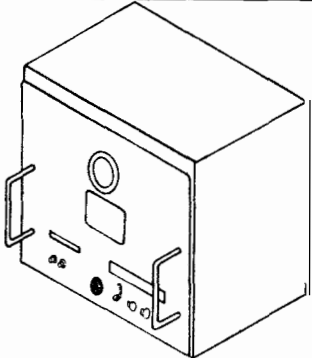
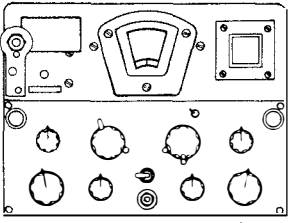
b. REPLACEMENT OF TUBES AND FUSES.—There are two fuses contained in the RBS-3 equipment. They are located in the Rectifier, Power-Amplifier Unit.

WARNING

Never replace a fuse with one of the higher rating unless continued operation of the equipment is more important than probable damage. If a fuse burns out immediately after replacement, do not replace it a second time until the cause for failure has been corrected.

(1) SYMPTOMS OF FUSE FAILURES.

TABLE 5-2. SYMPTOMS OF FUSE FAILURE

<i>Dial Lights</i>	<i>Pilot Light</i>	<i>Receiver Output</i>	<i>Amplifier Output</i>	<i>Fuse Blown</i>	<i>Value (amp)</i>
Out (with brightness control in MAX position)	Out	Dead	Dead	F-901 F-902 either or both	2 2

(2) LOCATION OF FUSES.

TABLE 5-3. FUSE LOCATION

<i>Fuse</i>	<i>Location</i>	<i>Protects</i>	<i>Amperes</i>	<i>Volts</i>
F-901	{ Front panel of Rectifier, Power Amplifier	{ Transformer primary of receiver, Power supply	2	250
F-902			2	250

(3) LOCATION OF TUBES.—All electron tubes used in the receiver and in the power amplifier unit are held in place by clamps which must be released before tubes can be removed. The tube symbol will be found

stamped into the chassis immediately adjacent to its associated socket. Tube locations can be determined from Figures 5-1 and 5-2.

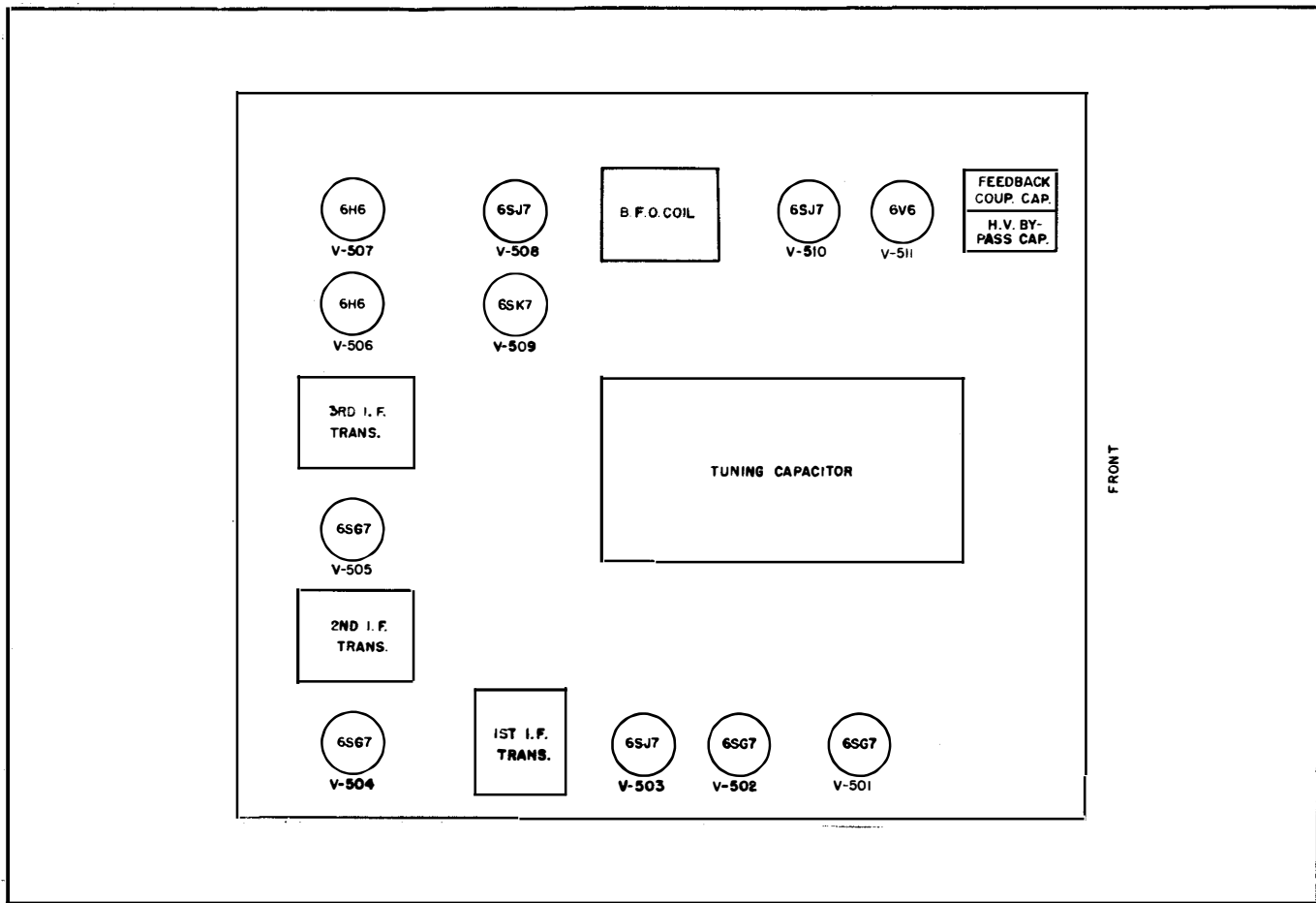

Figure 5-1. Radio Receiver Tube Locations

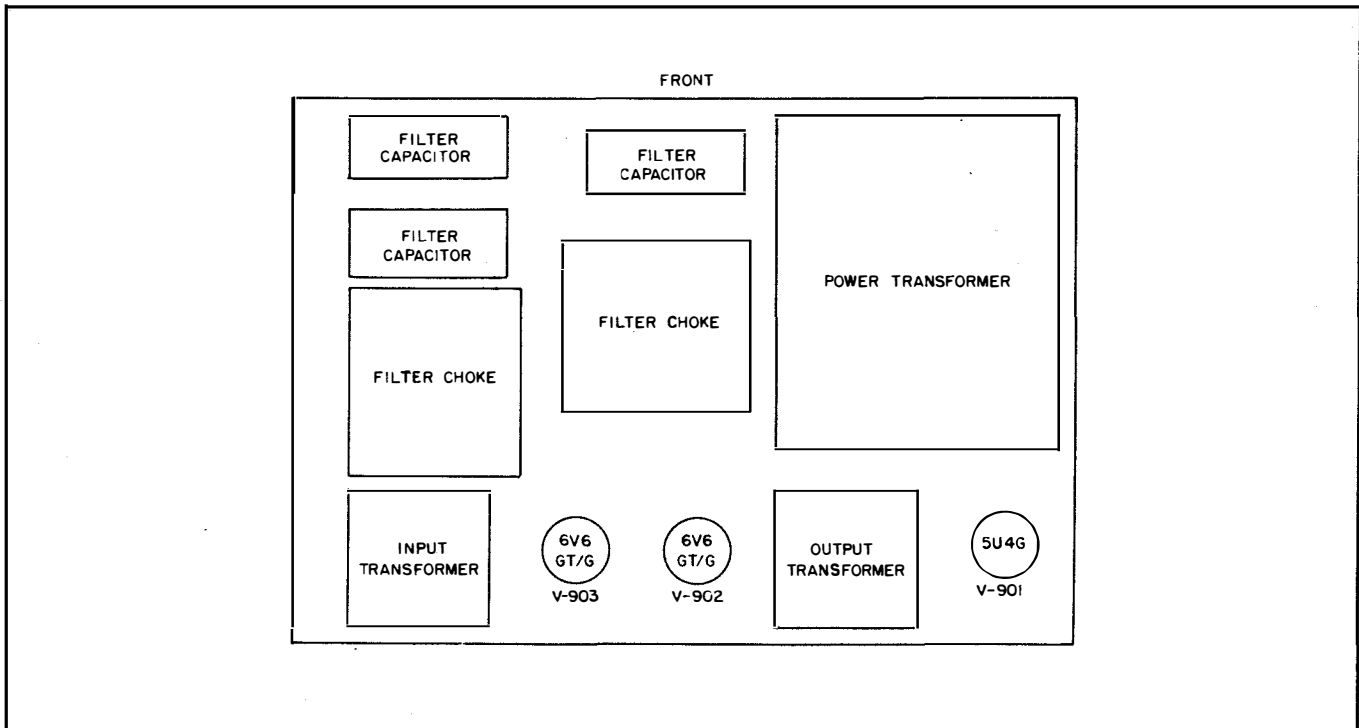

Figure 5-2. Rectifier Power Amplifier Tube Locations

SECTION 6 PREVENTIVE MAINTENANCE

I. ROUTINE MAINTENANCE CHECK CHARTS.

The following charts indicate the inspections to be performed and the intervals at which they are to be made. The tests indicated here are to be made in addition to those given in Table 5-1 of the Operator's Maintenance section.

Note

The attention of maintenance personnel is invited to the requirements of Chapter 67 of the "Bureau of Ships Manual", of the latest issue.

**TABLE 6-1. ROUTINE MAINTENANCE CHECK CHART
UNDERWAY — DAILY AND WEEKLY**

<i>What to Check</i>	<i>How to Check</i>	<i>What to do and Precautions</i>
A. Dial and Pilot Lamps	Turn on power and check visually to see that lamps are lighted.	Replace any defective lamp with appropriate one.
B. External Cables and Connectors	Check for frayed, pinched or cut cables; see that coupling rings are tightened properly and that the plugs are in position. Examine contacts for possible damage such as being bent or dirty.	Be certain power is not applied to equipment when checking for damaged cables. Repair or replace plugs or cables which might be electrically or mechanically defective.
C. Receiver Operation	Turn power switch to "ON". Set reception control to "CW", set the "OUTPUT LEVEL" control to 100, and set the gain control to approximately 90; check for reception on all bands throughout the entire tuning range.	If reception is faulty, refer to Section 7 for appropriate corrective measures. Be certain all plugs and connectors are in position.

**TABLE 6-2. ROUTINE MAINTENANCE CHECK CHART
UNDERWAY — MONTHLY**

A. ALL CHECKS LISTED IN PREVIOUS CHARTS TO BE PERFORMED FIRST.		
<i>What to Check</i>	<i>How to Check</i>	<i>What to do and Precautions</i>
B. Mountings	Visually check the receiver unit mountings and the power unit mountings for corrosion and/or looseness.	Clean off any corrosion with crocus cloth and tighten loose mountings.
C. Knobs and Handles	Rotate and jiggle all knobs and handles to see that they are firmly attached to the control shaft or screw.	Tighten all loose set screws or knobs. Replace broken or split knobs.
D. Screws and Nuts	Check looseness of any nut, check for missing or worn nuts, check for missing screws.	Tighten loose nuts, replace missing nuts, washers, or screws.
E. Noise Limiter and Power Switches	Operate switches ten times.	If contacts are defective, replace switch.
F. "GAIN" and "OUTPUT LEVEL" controls	Listen for noisy or erratic operation while either control is adjusted.	Replace control if defective.
G. "HEADPHONE LEVEL" control	Listen for noisy or erratic operation while control is adjusted.	Replace if defective.

**TABLE 6-3. ROUTINE MAINTENANCE CHECK CHART
UNDERWAY — QUARTERLY**

A. ALL CHECKS LISTED IN PREVIOUS CHARTS TO BE PERFORMED FIRST.		
<i>What to Check</i>	<i>How to Check</i>	<i>What to do and Precautions</i>
B. Cleanliness	(1) Remove receiver from its cabinet. This is done by disconnecting all wires and cables, removing the 29 holding screws on cabinet, and drawing the chassis forward. (2) Remove all dust from the interior with a clean dry cloth or a dry air blower. (3) Check for deterioration of components and broken connections. (4) Check mechanism of the precision dial and lubricate where necessary in accordance with paragraph 2 of this section.	The main power switch on the power amplifier should be in "OFF" position; the red pilot lamp should not be burning.
C. Circuit Components	Check visually for worn or burnt parts; if any component appears bad, remove and check with appropriate test instrument.	Remove suspected component from circuit before testing it.

**TABLE 6-4. ROUTINE MAINTENANCE CHECK CHART
UNDERWAY — SEMI-ANNUALLY**

A. ALL CHECKS LISTED IN PREVIOUS CHARTS TO BE PERFORMED FIRST.		
<i>What to Check</i>	<i>How to Check</i>	<i>What to do and Precautions</i>
B. Dial Mechanism	Refer to paragraph 2a of this Section.	Use type of oil indicated in Figure 6-1.
C. Sensitivity	Refer to Section 7, paragraph 7b(1)(b).	Be certain of tubes.
D. Noise Level	Refer to Section 7, paragraph 7b(1) for electrical adjustments and alignment procedures.	Be certain that any high noise level is not due to atmospheric disturbances or a.c. line hash.

**TABLE 6-5. ROUTINE MAINTENANCE CHECK CHART
UNDERWAY — ANNUALLY**

A. ALL CHECKS LISTED IN PREVIOUS CHARTS TO BE PERFORMED FIRST.		
<i>What to Check</i>	<i>How to Check</i>	<i>What to do and Precautions</i>
B. Alignment	Refer to Section 7, paragraph 7(b)1.	Turn on receiver one-half hour before test. Be sure of tubes in set.
C. Calibration	Check calibration for operating frequency with a Navy Model L-M or L-R frequency meter.	The receiver and the frequency meter should be turned on approximately one-half hour prior to checking.
D. Circuit Components	Check with appropriate instrument all points mentioned in Tables 7-2, 7-3, and 7-4.	Replace defective components. Be sure power is removed from receiver before making resistance checks.

Caution

Major adjustments and repairs should be made only by authorized maintenance personnel.

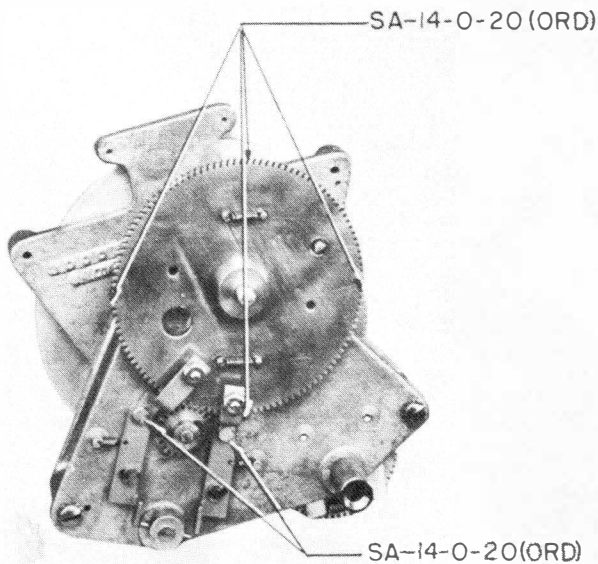

REAR VIEW

ANTI-BACKLASH GEAR
ONE DROP EVERY 90° APPLIED WITH TOOTHPICK ON TEETH ON THIS AND ALL ANTI-BACKLASH GEARS.

DETENT ARMS
ONE DROP APPLIED WITH TOOTHPICK AT PIVOT POINT.

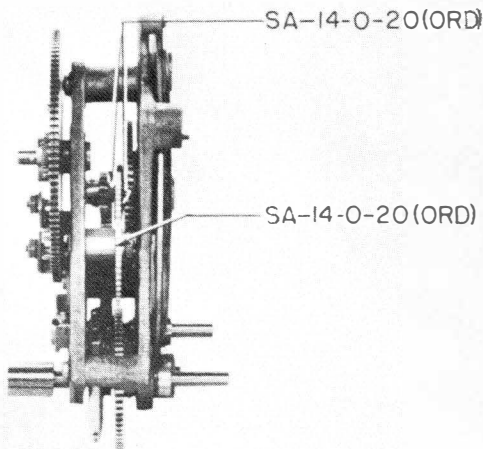

SIDE VIEW

DIAL GEAR
ONE DROP APPLIED WITH TOOTHPICK ON EACH SIDE OF GEAR.

BUSHING
ONE DROP APPLIED WITH TOOTHPICK BETWEEN BUSHING AND MASKING PLATE IDLER GEAR.

CAUTION
1. DO NOT OIL "OILITE" BUSHINGS IN ALUMINUM CASTINGS.
2. WIPE OFF ALL EXCESS.

LEGEND

SA - SEMI-ANNUALLY

SPECIFICATION NUMBER AND TITLE	STANDARD NAVY STOCK NUMBER — ONE PINT.
14-O-20(ORD) OIL, LUBRICATING, INSTRUMENT (SYNTHETIC)	W14-O-975-25

Figure 6-1. Tuning Dial Assembly U-501, Lubrication Data

TABLE 6-6. NAVY MODEL TEST EQUIPMENTS

<i>Test Equipment</i>	<i>Nomenclature</i>
Electronic Multimeter	Multimeter ME 25/U Series, or equivalent
Multimeter 20,000 ohm/volt DC 1,000 ohm/volt AC	Multimeter AN/PSM-4 Series, or equivalent
Tube Tester	Tube Tester TV 3/U Series, or equivalent
RF Signal Generator	RF Signal Generator Set AN/-URM-25 Series, or equivalent
AF Signal Generator	Audio Oscillator TS 382 A/U Series, or equivalent

2. LUBRICATION.

a. LUBRICATION OF THE PRECISION DIAL MECHANISM.—At six month intervals inspect gears and bearings of the precision dial mechanism. With toothpick or similar device apply lubricant conforming to Navy Spec. 14-0-20 (ORD) to the mechanism as

follows:

- (1) Place one drop at intervals of 90° along the toothed edge of all anti-backlash gears.
- (2) Place one drop at pivot point of each detent arm.

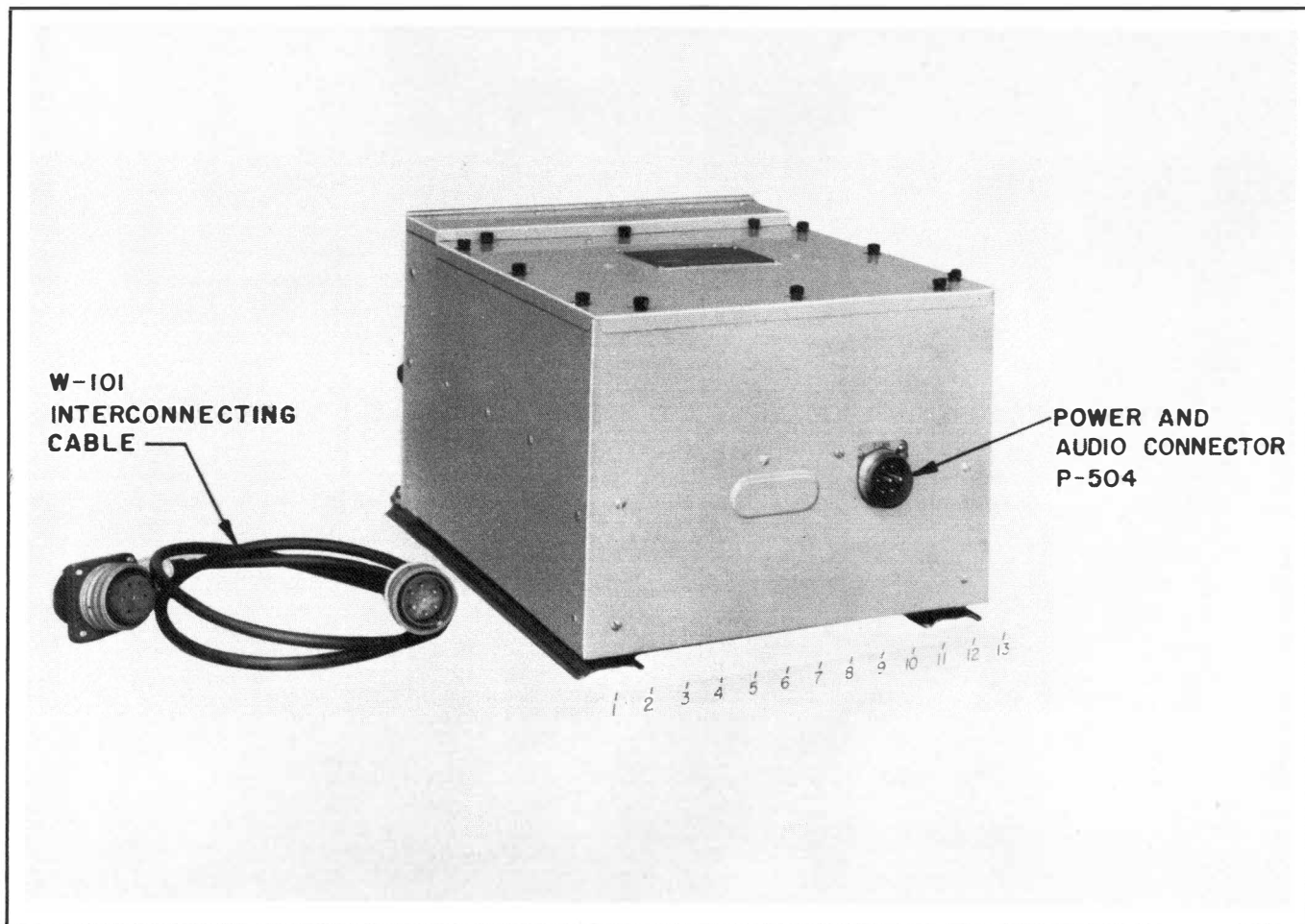

Figure 6-2. Radio Receiver Navy Type R-303/FRR, Left Rear View

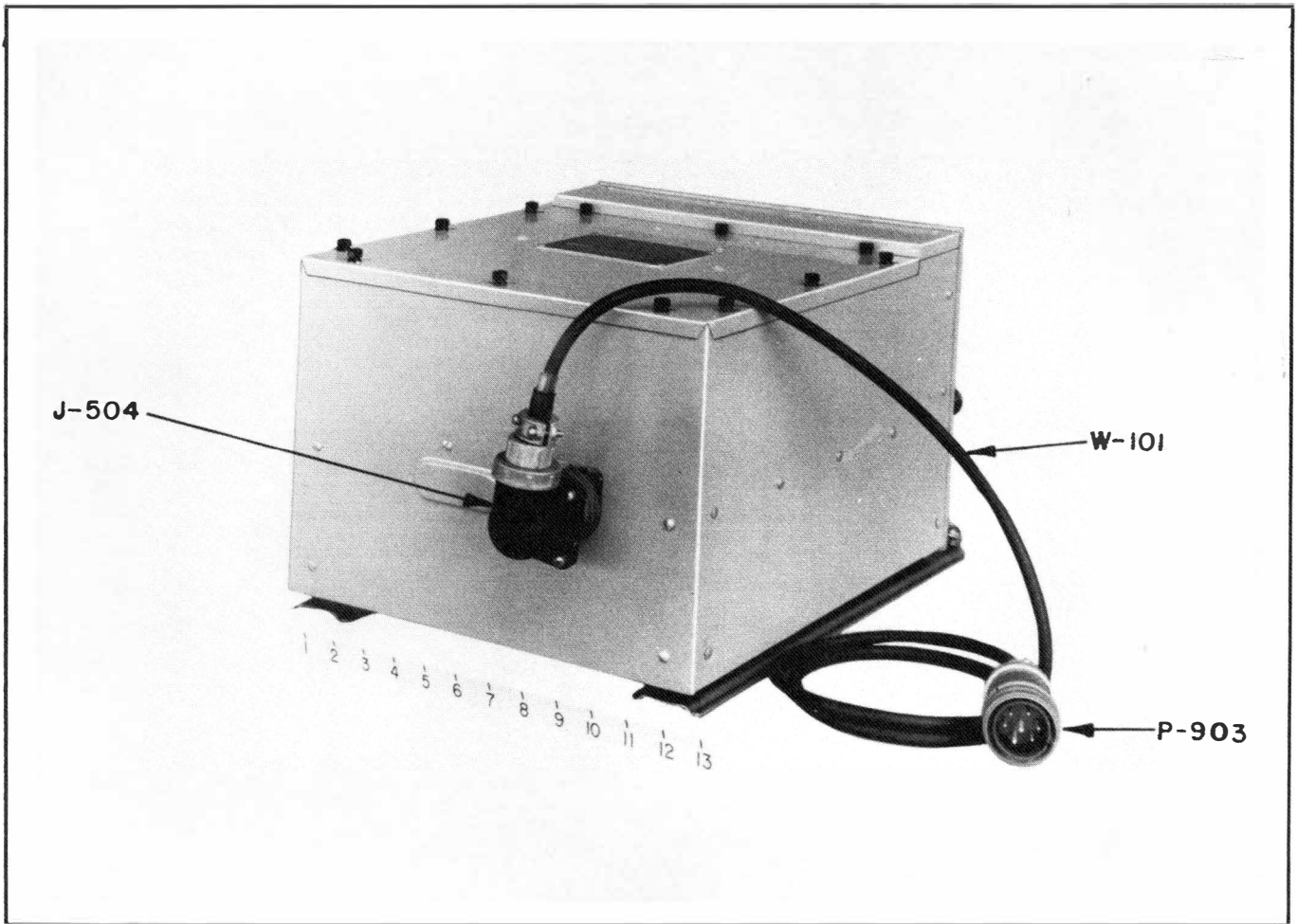

Figure 6-3. Radio Receiver Navy Type R-303/FRR, Right Rear View

(3) Place one drop between the bushing and the masking plate idler gear.

(4) Place one drop on each side of the dial gear.

(5) Do not lubricate excessively and wipe off any excess.

See Figures 1-4 and 6-1.

b. LUBRICATION OF ROTATING SHAFT MECHANISM.—Inspect the rotating shaft bearings of the "RECEPTION" and "SELECTIVITY" control switches. The "ANT COMP" (antenna compensation), and the "BEAT NOTE" controls every four months to see if lubrication is required. (See Figures 1-6 and 1-9). If necessary, lubricate with lubricant conforming to Navy Spec. 14-0-20 (ORD). One drop at each point is sufficient; wipe off excess.

3. UNCOVERING THE EQUIPMENT.

Caution

Before uncovering the units, make sure that "POWER ON-OFF" switch is on "OFF" position.

a. THE RECTIFIER POWER AMPLIFIER UNIT.—The front panel of the Rectifier Power Amplifier Unit forms an integral part of the chassis assembly and also completes the enclosure of the cabinet. The complete chassis assembly can be removed from the cabinet for tube changing, servicing, and other purposes without disturbing the mounting of the cabinet.

To remove the chassis assembly, disconnect three plug connections at the base of the chassis, loosen the captive thumbscrews attached to the front panel, and carefully pull the chassis assembly from the cabinet by the handles.

b. REMOVAL OF DUST COVER FROM RADIO RECEIVER.

- (1) Loosen the thumb screws on top of receiver.
- (2) Pull back and up on dust cover.

FAILURE REPORTS

A failure report must be filled out for the failure of any part of the equipment whether caused by defective or worn parts, improper operation, or external influences. It should be made on Failure Report, form NAVSHIPS 383, which has been designed to simplify this requirement. The card must be filled out and forwarded to BUSHIPS. Full instructions are to be found on each card.

Use great care in filling the card out to make certain it carries adequate information. For example under "Circuit Symbol" use the proper circuit identification taken from the schematic drawings, such as T-803, in the case of a transformer, or R-207, for a resistor. Do not substitute brevity for clarity. Use the back of the card to completely describe the cause of failure and attach an extra piece of paper if necessary.

The purpose of this report is to inform BUSHIPS of the cause and rate of failures. The information is used by the Bureau in the design of future equipment and in the maintenance of adequate supplies to keep the present equipment going. The cards you send in, together with those from hundreds of other ships, furnish a store of information permitting the Bureau to keep in touch with the performance of the equipment of your ship and all other ships of the Navy.

This report is not a requisition. You must request the replacement of parts through your Officer-in-Charge in the usual manner.

Make certain you have a supply of Failure Report cards and envelopes on board. They may be obtained from the nearest District Printing and Publication Office.

SECTION 7

CORRECTIVE MAINTENANCE

1. GENERAL.

The receiving equipment has been carefully adjusted and aligned at the factory, and given reasonable care, should remain in adjustment over a long period of time. However, such factors as tube aging, vibration, or severe shock of the tube elements may cause the sensitivity of the receiver to vary, and may necessitate repairs.

Caution

Major adjustments and repairs should be made only by authorized maintenance personnel.

2. FAILURE REPORT.

A failure report must be filled out for the failure of any part of the equipment, regardless of failure cause. This report must be forwarded to BUSHIPS; it is of vital importance and must be filled out without delay. (See page 7-0).

3. THEORY OF TROUBLE LOCALIZATION.

a. As the greatest majority of troubles in any electronic device will be in tube failure, the first step in

trouble shooting is to make a visual inspection of the tubes to see that they all light. Metal tubes can be checked by cautiously feeling the envelope to see if they are warm. After this step, the tubes can be checked in any standard Navy tube checker. Replace all defective tubes with new ones from spares. Check the replacement tube in the tube checker before inserting them in the set.

b. If the plates of the rectifier tube, type 5U4G, are so hot that they are red, check the filter capacitors, C-903, C-904, and C-905, in Figure 7-1 with an ohmmeter for shorts. All leads to these capacitors must be removed before tests are made on them. If a reading of less than 0.5 megohms occurs, replace the capacitor.

c. Loud hum or distorted voice is generally caused by breakdown of the secondary filter capacitors (C-904 or C-905). Remove all leads to the capacitors and check them with a high range ohmmeter (10 megohms or higher). If, when the ohmmeter leads are first touched to the capacitor terminals, there is no momentary surge of the meter pointer toward zero ohms, then the capacitor is defective and must be replaced.

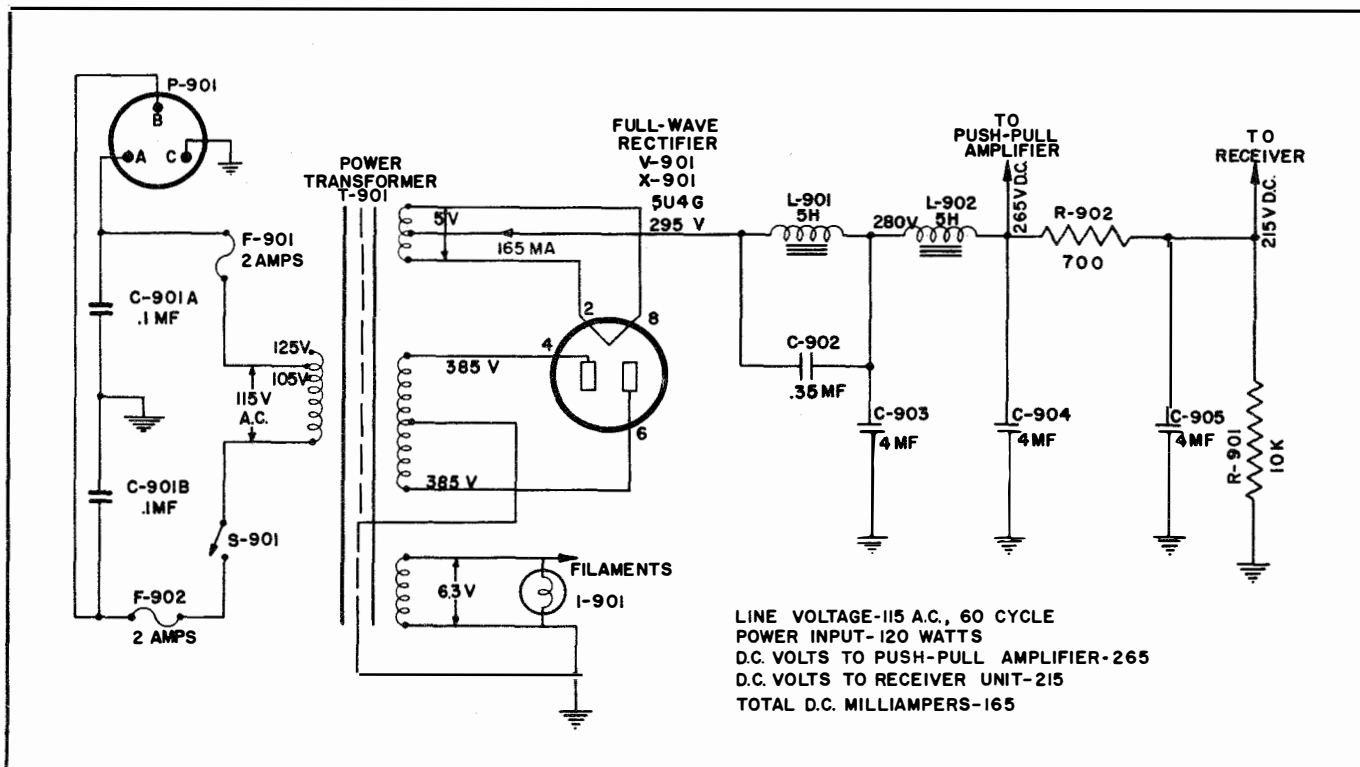

Figure 7-1. Power Supply and Filter Circuits

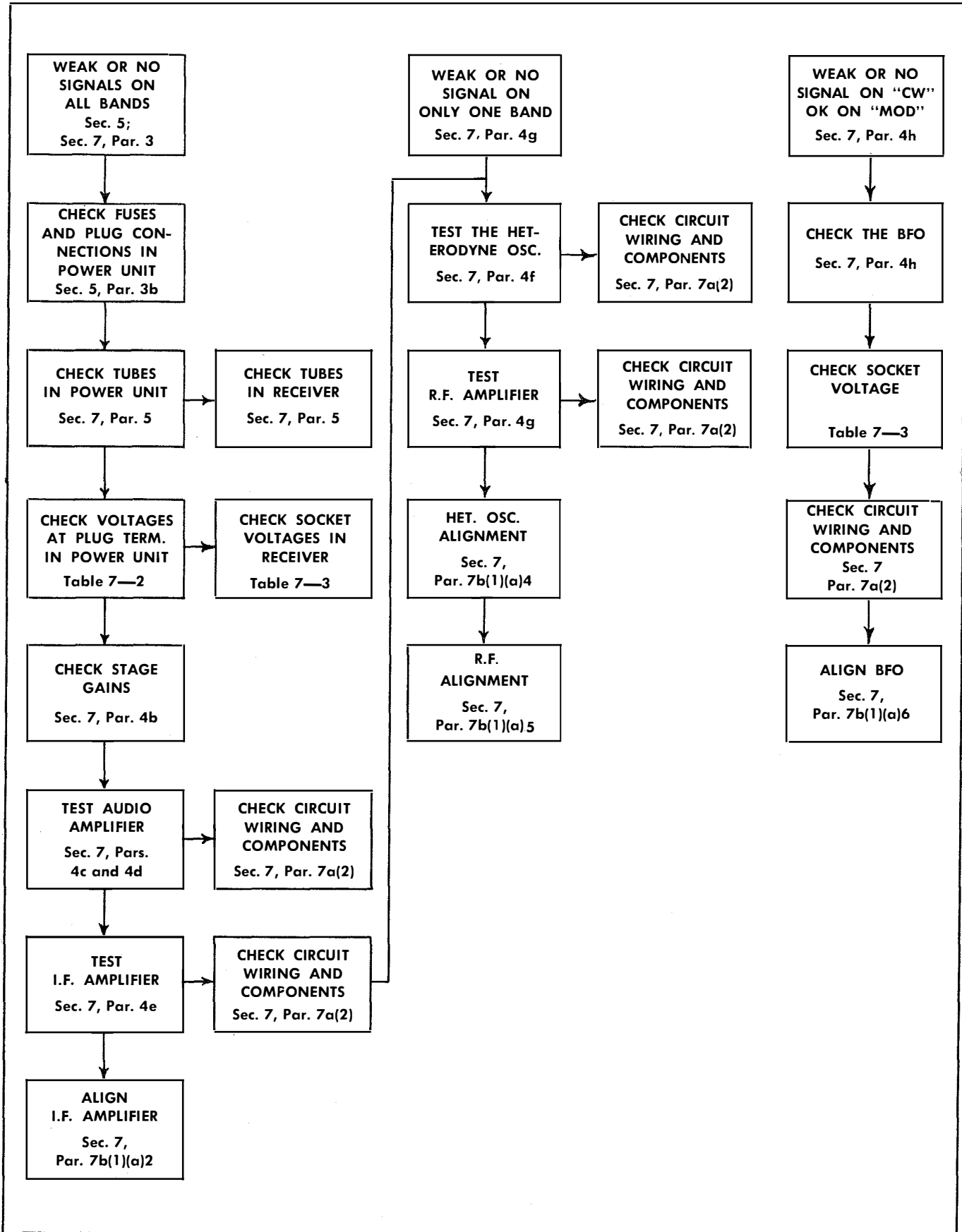

Figure 7-2. Stage by Stage Trouble Localization Diagram

d. Poor or distorted quality in the performance of the audio amplifier may be caused by either a gassy output tube, 6V6, or a defective coupling capacitor (C-566 of Figure 2-12). If replacement of the tube does not eliminate the trouble, check the grid voltage of the 6V6. It should be negative with respect to the cathode when no signal is applied to the receiver. If positive even a slight amount, replace the coupling capacitor, (C-566).

e. Normally, coils will not have to be replaced except for combat casualties. Do not tamper with the alignment. A quick check of the alignment can be made with the signal from a type AN/URM-25 or Navy LP signal generator and heterodyne frequency meter. However, if a signal comes through, and it is found that, after following the procedure of checking sensitivity given in paragraph 7b(1)(b) 1 of this section, the sensitivity of the set meets the limits set in the sensitivity chart shown there, suspect the antenna system. Try the set on another antenna trunk before working on the R.F. or I.F. section. Quite often the static discharger in the antenna terminal box will fail, and the antenna will then be practically grounded. Check the antenna with another receiver.

f. If the sensitivity, as determined by following the methods of paragraph 7b(1)(b)1, is less than that given in the sensitivity chart in paragraph 7b(1)(b)1 of this section, and all other causes have been checked, it might be suspected that the trouble lies in the R.F. or I.F. coils. Set up the receiver with a signal generator for alignment as described in 7b(1)(a) of this section. If any coil will not peak, then that coil is defective. Replace the coil, and re-align. Be sure when replacing any coil, that the leads are redressed as they were originally, or difficulty may be experienced in obtaining satisfactory alignment. Follow the alignment procedure as outlined in 7b(1)(a).

g. Persistent fuse blowing is generally caused by either a defective rectifier tube, type 5U4G, or shorted or leaky filter capacitors. Rarely is this trouble caused by a shorted connecting cable. Use an ohmmeter to check.

4. SYSTEM TROUBLE SHOOTING.

a. PRELIMINARY CHECKS.—When the equipment becomes inoperative, or operates inefficiently, look first for simple causes of failures, which may be located by the following preliminary checks:

(1) Check the fuses on the Rectifier Power-Amplifier Unit. Replace any defective fuses.

(2) Check the line voltage for 115 volts A.C.

(3) Check all plug connections.

(4) Check the antenna connections.

(5) Check all tubes. (Refer to this section, paragraph 5). Replace any defective tubes.

(6) Check the power supply output voltage, as follows:

(a) Measure the voltages between terminals C and G of receptacle J-903. The reading should be 215 volts D.C. \pm 10 per cent. (See Figure 7-21).

(b) Measure the voltage between pins No. 4 of V-902 and V-903 and ground. The reading should be approximately 265 volts D.C. (See Table 7-2 and Figure 7-1).

(c) If the voltages measured do not approximate the correct values, both the receiver and power supply units should be given a thorough voltage and continuity check, and all defective components and tubes replaced. (See Tables 7-1, 7-2, and 7-4, and Figures 7-2, 7-3, 7-4, and 7-20, 7-21. If it is desired to check the power supply voltage independently of the Radio Receiver, substitute dummy loads in place of the receiver, as follows:

1. Connect a dummy load of approximately 2200 ohms capable of dissipating 40 watts in the 215-volt D.C. output at terminals C and G of J-903 and adjust it to draw approximately 95 milliamperes. The voltage across the load should be 215 volts \pm 10 per cent.

2. Connect a dummy load of approximately 6 ohms capable of dissipating 50 watts across the filament supply output at terminals B and G of J-903 and adjust it to draw approximately 2.05 amperes. The A.C. voltage across this load should be 6.3 volts \pm 5 per cent.

b. GENERAL.—If the preliminary checks and replacements fail to restore the equipment to operating condition, isolate the trouble to one or more stages, so that defective components can be quickly located and replaced. Various methods of localizing trouble can be used. (See Figure 7-2). Sometimes the trouble can be localized by noting the nature of the symptoms. If the receiver operates on all bands except one, the I.F. and the audio stages are functioning and it is only necessary to check the R.F. stage of the defective band. (Refer to this section, paragraph 4g). The method of localizing trouble by gain measurements described below, uses the Navy Model OE Series Receiver Analyzer, a 20,000 ohm per volt multimeter such as the AN/PSM-4 Series, or equivalent, an R.F. Signal Generator set AN/URM-25 series, or equivalent, modulated 30 percent at 1000 cycles, and an audio oscillator such as Audio Oscillator TS-382A/U or higher.

(1) GAIN MEASUREMENTS.—The stage gains chart given in Table 7-1 below will be referred to throughout this paragraph on trouble localization. The term "gain" as used here is defined as the ratio of the signal generator voltage taken at the output of the stage, to the voltage taken at the input of the stage, the output level remaining constant as specified in setting (f) below. Unless otherwise specified, when using the stage gains chart by itself or in conjunction with the test procedures which follow the chart, make the following adjustments:

(a) Adjust the "GAIN" control so that the po-

tential between the chassis and pins Nos. 3 and 5 of tubes V-504 and V-505 respectively is 3.0 volts.

(b) Set the "RECEPTION" control to "MOD".

(c) Set the "OUTPUT LEVEL" control to 100.

(d) Set the "NOISE LIMITER" switch to "OFF".

(e) Modulate the signal generator 30 per cent at 1000 cycles.

(f) Adjust the signal generator so that the receiver delivers 1.9 volts across a 600 ohm non-inductive resistance load connected to the received "PHONES" jack J-503.

TABLE 7-1. STAGE GAINS CHART

Stage	Input to Terminal	Socket	Frequency Mc.	Band	Gain Limits	Selectivity Control
Det. and Audio System	3	X-506	1.255		0.28-0.66 volt input	
2nd I.F. Amp.	4	X-505	1.255		24-56	
1st I.F. Amp.	4	X-504	1.255		17-39 17-39	Sharp Broad
Converter	4	X-502	1.255		4-10 4-10	Sharp Broad
R.F. Amp. *1	4	X-501	3.6 6.5 11.4 20.0	1 2 3 4	9-21 10-22 18-42 5-13	
Antenna *1, *2	Antenna Terminal		3.6 6.5 11.4 20.0	1 2 3 4	3-7 2-5 2-5 1.4-3.2	

*1. "ANT COMP" adjusted for maximum output for each band.

*2. Signal applied to IRE Standard Dummy Antenna (which is furnished as a part of both the AN/URM-25 and Model LP signal generator) connected to receiver input.

c. LOCATING TROUBLE IN THE PUSH-PULL AMPLIFIER.

(1) Connect an output meter between terminals C and D of receptacle J-902 and disconnect the loudspeaker plug P-902. Use a 600-ohm non-inductive resistor with an electronic voltmeter.

(2) Connect the output terminal of an audio frequency oscillator, tuned to approximately 1000 cycles, to a test prod through a 5000 micromicrofarad capacitor.

(3) Touch the test prod first to pin No. 3 (plate)

and then to pin No. 5 (grid) of both tubes V-902 and V-903. When the test prod is touched to pin No. 5 the output meter reading should be at least 2.5 times the reading obtained when the test prod is touched to pin No. 3. Keep the audio signal to the lowest possible level.

(4) Touch the test prod to terminal F of receptacle J-903. When the test prod is touched to pin No. 5 of either tube V-902 or tube V-903, the output meter should read 1.41 times the reading at terminal F.

(5) If the output reading fails to increase when

the test prod is moved from one point to the next one farther away from the output, there is some defect in the circuit between the two check points. Analyze and repair the defective circuit by the following method:

(a) Inspect the chassis for broken, shorted, or burned wiring and components.

(b) Make a thorough voltage and resistance check, using the values given in Table 7-2 as a standard.

(c) Replace all defective parts.

(d) Replace the tubes in the circuit by others known to be good.

**TABLE 7-2. RECTIFIER POWER AMPLIFIER UNIT, VOLTAGE AND RESISTANCE CHART
(Tube Socket Terminals to Chassis)**

RECTIFIER — POWER AMPLIFIER RESISTANCE CHART										
Socket	Stage	Tube	1	2	3	4	5	6	7	8
X-901	Rectifier	5U4G	Open	10,900	Open	44	Open	47	Open	10,900
X-902	Push-Pull	6V6GT/G	Open	0.10	10,750	10,700	54	Open	1 1/4 to 7	200
X-903	Push-Pull	6V6GT/G	Open	1 1/4 to 7	10,750	10,700	62	Open	0	200

All interconnecting cables disconnected. Good tubes and pilotlamp in their respective sockets.

RECTIFIER — POWER AMPLIFIER UNIT VOLTAGE CHART										
Socket	Stage	Tube	1	2	3	4	5	6	7	8
X-901	Rectifier	5U4G	—	295	—	385*	—	385*	—	295
X-902	Push-Pull	6V6GT/G	—	12.6*	255	265	0	—	0	15
X-903	Push-Pull	6V6GT/G	—	6.3*	255	265	0	—	6.3*	15
J-903	Terminal Number C has 210 Volts D.C. Terminal Number B has 6.3 Volts A.C.									

NOTE: All voltages are D.C. unless otherwise specified and were measured between the indicated tube-socket pin and ground. The D.C. voltages are taken with a 20,000 ohms/volt D.C. voltmeter and the A.C. voltages are taken with a 1,000 ohm/volt A.C. voltmeter.

*Denotes alternating current, "RECEPTION" control set to "CW".

All interconnecting cables are connected. Good tubes and pilotlamps in their respective sockets.

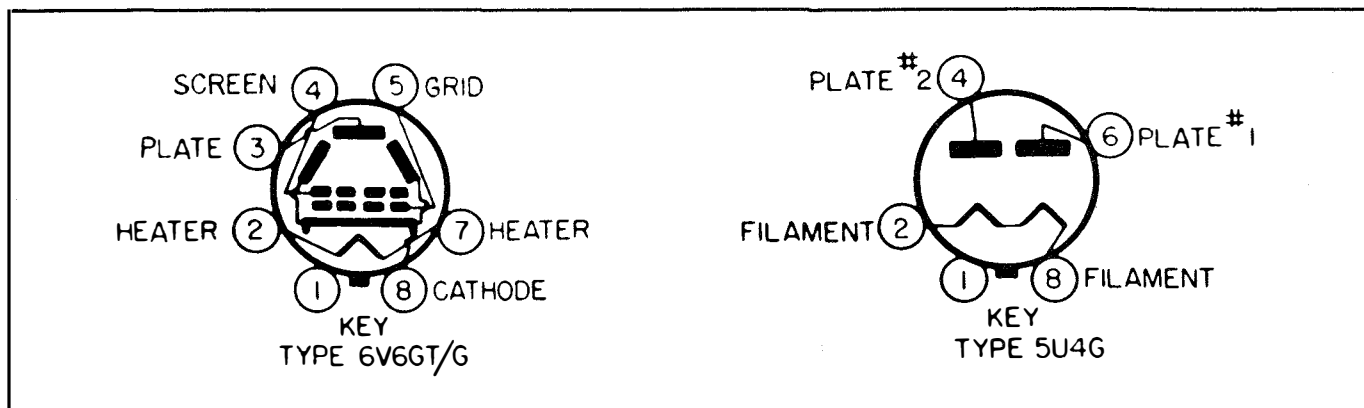

Figure 7-3. Rectifier-Power Amplifier, Tube Socket Diagram

d. LOCATING TROUBLE IN THE AUDIO AMPLIFIER.

(1) Attach an electronic multimeter in parallel with a non-inductive 600-ohm load to the receiver "PHONES" jack J-503.

(2) Connect the output terminal of an audio fre-

quency oscillator, tuned to approximately 1000 cycles, to a test prod through a 5000 micromicrofarad capacitor.

(3) Set the equipment controls as follows: "RECEPTION" control to "MOD", "OUTPUT LEVEL" control to 100, and "NOISE LIMITER" switch to "OFF".

TABLE 7-3. RADIO RECEIVER, VOLTAGE CHART.

Socket Symbol	Stage	Tube	(Socket Terminal Number)					
			3	4	5	6	7	8
X-501	R.F.	6SG7	1.8v	0	1.8v	120v	6.3v	200v
X-502	Conv.	6SG7	5.4v	0	5.4v	145v	6.3v	205v
X-503	Het. Osc.	6SJ7	145v	-4.6v	0v	145v	6.3v	185v
X-504	1 I.F.	6SG7	1.7v	0v	1.7v	120v	6.3v	195v
X-505	2 I.F.	6SG7	1.7v	0v	1.7v	120v	6.3v	195v
X-506	2 Det.	6H6	-4.2v	0v	-2.6v	0v	6.3v	-1.8v
X-507	A.G.C.	6H6	0v	8.2v	0v	—	6.3v	0v
X-508	B.F.O.	6SJ7	0v	-4.4v	0v	34v	6.3v	140v
X-509	1 A.F.	6SK7	0v	0v	1.7v	34v	6.3v	62v
X-510	2 A.F.	6SJ7	9.2v	0v	9.2v	170v	6.3v	78v
X-511	3 A.F.	6V6	110v	115v	0v	9.2v	6.3v	6v
P-504	Terminal Number C has 210 volts D.C. Terminal Number B has 6.3 volts A.C.							

Readings taken with a voltmeter, which has 20,000 ohms/volt for D.C. voltage and 1,000 ohms/volt for A.C. voltage.

All voltages are D.C. unless otherwise noted and are measured between the indicated tube socket pin and ground, with good tubes in their respective sockets, and all interconnecting cables connected.

"RECEPTION" control set to "CW". "POWER" switch "ON". "NOISE LIMITER" switch "OFF". "GAIN CONTROL" set at "100".

*Denotes A.C.

TABLE 7-4. RADIO RECEIVER, RESISTANCE CHART.

Socket	Range	Tube	(Tube Socket Terminals)							
			1	2	3	4	5	6	7	8
X-501	R.F.	6SG7	0	0	160	2.75 Meg *3.16 Meg	160	18400	0.5	18700
X-502	Conv.	6SG7	0	0	1500	2.30 Meg *4.10 Meg	1500	84500	0.5	18700
X-503	Het. Osc.	6SJ7	0	0	51700	20000	0	51700	0.5	19200
X-504	1st I.F.	6SG7	0	0	150	0.55 Meg *0.96 Meg	150	18400	0.5	18700
X-505	2nd I.F.	6SG7	0	0	150	2.20 Meg	150	18400	0.5	18700
X-506	2nd Det.	6H6	0	0	0.44 Meg	0	0.22 Meg	0.35 Meg *1.33 Meg	0.5	2.12 Meg
X-507	A.G.C.	6H6	0	0	0.35 Meg *1.33 Meg	2900	0	—	0.5	0
X-508	B.F.O.	6SG7	0	0	0	47000	0.8	0.50 Meg	0.5	73500
X-509	1st A.F.	6SK7	0	0	0 *1.80 Meg	2.20 Meg *2.59 Meg	1000	0.45 Meg	0.5	0.13 Meg
X-510	2nd A.F.	6SJ7	0	0	15000	1.47 Meg	15000	0.11 Meg	0.5	0.28 Meg
X-511	3rd A.F.	6V6	0	0	27000	26500	0.47 Meg	15000	0.5	620

*"RECEPTION" control set at "AGC".

The above readings are applicable under the following conditions: (1) Power input cable disconnected. (2) "GAIN" control set at 100. (3) "RECEPTION" control set at "CW", unless otherwise specified. (4) Good tubes in all sockets. (5) Dial-light dimmer control rotated fully clockwise.

All resistances read to ground.

(4) Touch the test prod to the following points, in the order given: pin No. 3 of V-511, Pin No. 5 of V-511, pin No. 4 of V-510, pin No. 4 of V-509, and pin No. 3 of V-506. (See Figures 7-4 and 7-21).

(5) If the output reading fails to increase when the test prod is moved from one point to the next point farther away from the output, there is some defect in the circuit between the two check points. Analyze and repair the defective circuit by the following method:

(a) Inspect the chassis for broken, shorted, or burned wiring and components.

(b) Make a thorough voltage and resistance

check, using the values given in Tables 7-4 and 7-3 as standard.

(c) Replace all defective parts.

(d) Replace the tubes in the circuit by others known to be good.

(6) To make an exact check of the gain of the audio amplifier, adjust the R.F. signal generator to produce a signal of 1255 kilocycles, modulated 30 percent at 1000 cycles, and couple the signal through a 500 micromicrofarad capacitor to pin No. 3 of tube V-506. With a signal generator output of 0.47 volt \pm 40 per cent the output meter at the receiver "PHONES" jack should read at least 1.9 volts across the 600-ohm load.

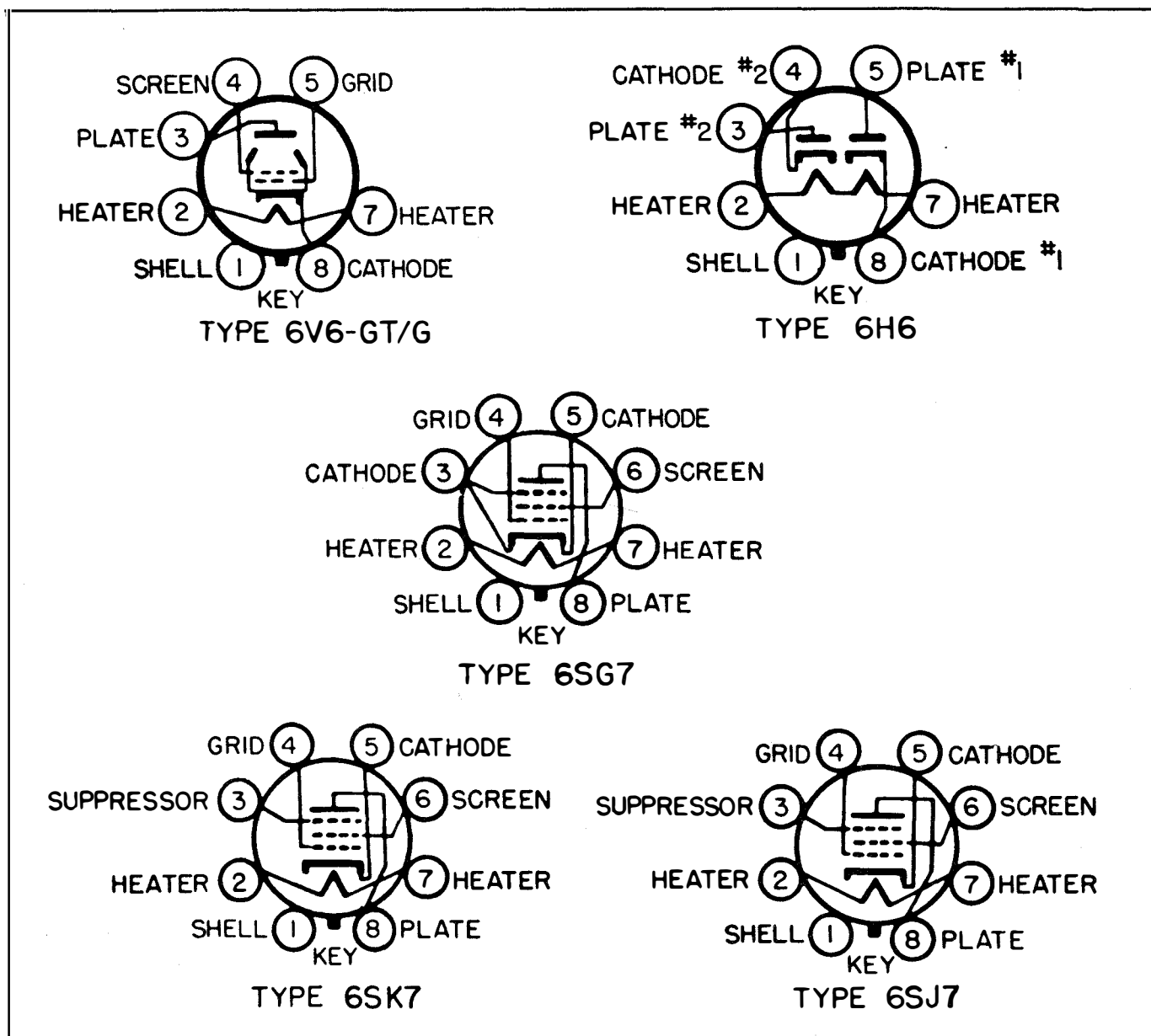

Figure 7-4 Radio Receiver, Tube Socket Diagram

TABLE 7-5. RATED TUBE CHARACTERISTICS

Tube	Heater		Screen Volts	Plate Volts	Grid Volts	Plate Ma.	Screen Ma.	Plate Transconductance	
	Volts	Amps						Res. Ohms	Micromhos
6SG7	6.3	0.3	250	250	-2.5	9.2	3.4	Greater than 1.0 megohm	4,000
6SJ7	6.3	.03	100	250	-3.0	3.0	0.8	Greater than 1.0 megohm	1,650
6H6	6.3	0.3			There are no d.c. applied voltages in tube 6H6.				
6SK7	6.3	0.3	100	250	-3.0	9.2	2.6	0.8 megohm	2,000
6V6-GT/G	6.3	0.45	250	250	-12.5	45.0	4.5	50,000 ohms	4,100
					Measurements under zero signal				
5U4G	5.0	3.0	—	325 RMS per plate	—	165	—	—	—

Values shown are average characteristic ratings for the type of tube, and are not necessarily the values at which they are operated in this equipment.

e. LOCATING TROUBLE IN THE INTERMEDIATE FREQUENCY AMPLIFIER.

(1) Connect an electronic multimeter in parallel with a 600-ohm load to the receiver "PHONES" jack J-503.

(2) Make the following receiver control adjustments:

(a) Adjust the "GAIN" control so that the potential between the chassis and pin No. 3 or pin No. 5 of tubes V-504 and V-505 is 3 volts.

(b) Set the "RECEPTION" control to "MOD".

(c) Set the "OUTPUT LEVEL" control to 100.

(d) Set the "NOISE LIMITER" switch to "OFF".

(3) Tune the modulated signal generator to 1255 kilocycles. Connect a short lead with a clip to the signal generator output through a 500-micromicrofarad capacitor.

(4) Connect the test clip to pin No. 3 of tube V-506 and adjust the signal generator output until the receiver output meter reads 1.9 volts across the 600-ohm load resistor. Note the signal generator microvolts output reading.

(5) Move the test clip to pin No. 4 of tube V-505 and adjust the signal generator output until the receiver output meter again reads 1.9 volts across the 600-ohm load resistor. Determine the gain of the second I.F. stage by dividing the signal generator microvolts input to pin No. 3 of the tube V-506 by the microvolts input to pin No. 4 of tube V-505. The gain of this stage should

fall between 24 and 56. (Refer to the Stage Gains Chart, this section, Table 7-1).

(6) Move the test clip to pin No. 4 of tube V-504 and adjust the generator output until the receiver output is 1.9 volts. Determine the gain of the first I.F. stage by dividing the signal generator microvolts input to pin No. 4 of tube V-505 by the microvolts input to pin No. 4 of tube V-504. Perform this test using both the "BROAD" and the "SHARP" positions of the "SELECTIVITY" control. (Refer to the Stage Gains Chart for the correct gain limits.)

(7) Move the test clip to pin No. 4 of tube V-502 and again measure the stage gain, this time of the converter stage, using both the "BROAD" and the "SHARP" positions of the "SELECTIVITY" control.

(8) If the gain of either stage falls below the limits given in the Stage Gains Chart, the stage is not operating correctly. Analyze and repair it, using the following procedure:

(a) Inspect the chassis for broken, shorted, or burned wiring and components.

(b) Make a thorough voltage and resistance check, using the values given in Tables 7-3 and 7-4 as standard.

(c) Replace all defective parts.

(d) Replace the tube in the stage under test by one known to be good.

(e) If all the voltages and resistances are correct, and the stage gain is beyond the limits given in

the Stage Gains Chart, realign the particular stage under test by the method given in this section, paragraph 7.

(9) To check the overall gain of the I.F. amplifier, connect the test clip to pin No. 4 of tube V-502. With the "SELECTIVITY" control in "SHARP" position, a signal generator output of 62 microvolts \pm 25 per cent approx. should produce a receiver output of 1.9 volts across the 600-ohm load resistor.

f. LOCATING TROUBLE IN THE HETERODYNE OSCILLATOR.

(1) Connect an electronic multimeter in parallel with a 600-ohm load to the receiver "PHONES" jack J-503.

(2) Make the following receiver control adjustments:

(a) Adjust the "GAIN" control so that the potential between the chassis and pin No. 3 or No. 5 of tubes V-504 and V-505 is 3.0 volts.

(b) Set the "RECEPTION" control to "MOD".

(c) Set the "OUTPUT LEVEL" control to 100.

(d) Set the "NOISE LIMITER" switch to "OFF".

(e) Set the "SELECTIVITY" control to "SHARP".

(3) Connect the signal generator through a 500-micromicrofarad capacitor to pin No. 4 of the converter tube V-502.

(4) Tune the signal generator and the receiver to the high frequency end of the band under test, and adjust the signal generator output until the receiver output meter reads 1.9 volts.

(5) If there is no response, or if the signal input required to obtain 1.9 volts output is higher than 100 microvolts, check the circuit for grounds, shorts, and defective components.

g. LOCATING TROUBLE IN THE RADIO FREQUENCY AMPLIFIER.

(1) Connect an electronic multimeter in parallel with a 600-ohm load to the receiver "PHONE" jack J-503.

(2) Make the following receiver control adjustments:

(a) Adjust the "GAIN" control so that the potential between the chassis and pin No. 3 or pin No. 5 of tubes V-504 and V-505 is 3.0 volts.

(b) Set the "RECEPTION" control to "MOD".

(c) Set the "NOISE LIMITER" switch to "OFF".

(d) Set the "SELECTIVITY" control to either "BROAD" or "SHARP".

(3) Connect a test clip to the output of the signal generator through a 500-micromicrofarad capacitor.

(4) Tune the signal generator and the receiver to the high frequency end of the band under test, using the frequencies listed in the Stage Gains Chart.

(5) Connect the test clip to pin No. 4 of the R.F. amplifier tube V-501 and adjust the signal generator output until the receiver output meter reads 1.9 volts. Adjust the "ANT. COMP" for maximum output. Note the generator microvolts input reading.

(6) Move the test clip to pin No. 4 of the converter tube V-502 and adjust the signal generator output until the receiver output meter again reads 1.9 volts. Determine the gain of the R.F. amplifier by dividing the signal generator microvolts input to pin No. 4 of V-502 by the microvolts input to pin No. 4 of V-501. Refer to the Stage Gains Chart (this section, Table 7-1) for the correct value of stage gain.

(7) Connect the signal generator to the antenna terminal through the standard dummy antenna and adjust the signal generator output until the receiver output meter reads 1.9 volts. Peak the "ANT. COMP" to maximum output. Divide the microvolts input to pin No. 4 of V-501 by the microvolts input to the antenna terminal to determine the antenna stage gain.

(8) If the gain of either the R.F. or the antenna stage is not within the limits given in the Stage Gains Chart, it is not operating correctly. Analyze and repair it by the following methods:

(a) Inspect the chassis for broken, shorted, or burned wiring and components.

(b) Make a thorough voltage and resistance check, using values given in Tables 7-3 and 7-4 as standard.

(c) Replace all defective components.

(d) Replace the tube in the stage by one known to be good.

(e) If all voltages, resistances, and continuity measurements are correct, and the stage gain is below normal, realign the stage under test by the method given in this section, paragraph 7.

b. LOCATING TROUBLE IN THE BEAT FREQUENCY OSCILLATOR.

If the receiver functions perfectly on a modulated signal, but has little or no audio output on an unmodu-

lated signal, with the "RECEPTION" switch set at "CW", the beat frequency oscillator "BFO" circuit is probably not operating, and should be analyzed and repaired by the methods given in this section, paragraph 4e(8)(a), (b), (c), and (d).

5. ELECTRON TUBE TESTS.

Use a tube tester TV3/U series or a Navy model OZ tube analyzer to check the tubes in the equipment for transconductance, emission, shorted elements, and open heaters when tube trouble is suspected. If no analyzer is available, replace all tubes from the spare parts with a set of tubes known to be of average characteristics. (See Table 7-5).

THE QUANTITIES OF ALL TUBES SUPPLIED WITH THE EQUIPMENT SHALL BE DEPLETED PRIOR TO EMPLOYMENT OF TUBES FROM GENERAL STOCK. Base diagrams of all tubes used in the equipment will be found in Figures 7-3 and 7-4.

6. VOLTAGE AND RESISTANCE MEASUREMENTS.

Adjust the line voltage to exactly 115 volts A.C. and measure the voltage and resistance values of the equipment with a multimeter, comparing the measurements with those shown on the charts in Tables 7-2, 7-3, and 7-4. Meter indications within 10 per cent of the chart values will, in most cases, indicate proper operation.

Caution

Remove power from equipment before taking resistance measurements.

7. UNIT TROUBLE SHOOTING AND REPAIR.

a. TROUBLE SHOOTING.

(1) TROUBLE SHOOTING CHART.—The trouble shooting chart of Figure 7-1 should be used by the technician to trace the source of any trouble developing in the receiver unit. The troubles may be localized by their symptoms as indicated by the chart.

(2) CIRCUIT CONSTANTS.

(a) Figures 7-20 and 7-21 are illustrations showing the relative location of the circuit components with appropriate symbols.

(b) Figures 7-20 and 7-21 show the relative locations of the tube sockets for each major unit. This drawing is viewed from the wiring or the under side of the chassis.

b. REPAIR.

(1) ELECTRICAL ADJUSTMENTS.

(a) ALIGNMENT PROCEDURE.

Note

No attempt should be made to realign the receiver unless the sensitivity, as measured by the methods of paragraph 7b(1)(b)1 of this section, is found to be less than 25 microvolts with new tubes known to be of average characteristics. Never attempt to align a dead set.

1. SETTING UP EQUIPMENT FOR ALIGNMENT.—Unless otherwise directed, set up the equipment for all alignment procedure as follows:

Step a. Attach a multimeter in parallel with a 600-ohm non-inductive load to the receiver "PHONES" jack J-503.

Step b. Connect a short test lead with clip to the output of the standard signal generator through a 500-micromicrofarad capacitor.

Step c. Make the following receiver control adjustments:

(a) Adjust the "GAIN" control so that the potential between the chassis and pin No. 3 or pin No. 5 of tubes V-504 and V-505 is 3.0 volts.

(b) Set the "RECEPTION" control to "MOD".

(c) Set the "NOISE LIMITER" switch to "OFF".

(d) Set the "SELECTIVITY" control to "SHARP".

(e) Set the "FREQ BAND" to 1.

(f) Adjust the "TUNING" control to 3.6 megacycles.

2. INTERMEDIATE FREQUENCY AMPLIFIER ALIGNMENT.

Step a. Connect the signal generator clip to converter grid, pin No. 4 of V-502.

Step b. Adjust the signal generator to supply a 1255 kilocycles signal modulated 30 per cent at 1000 cycles.

Step c. Align trimmer capacitors C-551A, C-551B, C-545A, C-545B, C-540A and C-540B (Figure 7-19) in the order listed, for maximum receiver output. Reduce the signal input, keeping the receiver output below 5.5 volts during alignment of the trimmers so as to prevent overloading.

Step d. This alignment is effective for both the "BROAD" and "SHARP" positions of the "SELECTIVITY" control. After alignment, the intermediate-frequency stage gain should fall within the values given

in the Stage Gains Chart. (Refer to Table 1 of this section.)

3. HETERODYNE OSCILLATOR AND R.F. AMPLIFIER ALIGNMENT TABLE.—The following table gives the frequencies for alignment of the heterodyne oscillator and the R.F. amplifier, in accordance with the procedure outlined in paragraphs 4 and 5 of this section.

HETERODYNE OSCILLATOR ALIGNMENT

<u>Band</u>	<u>Adjust Trimmer</u>	<u>At Freq. (MC)</u>	<u>Adjust Induc.</u>	<u>At Freq. (MC)</u>
1	C-536	3.6	L-516	2.05
2	C-535	6.5	L-515	3.70
3	C-534	11.4	L-514	6.50
4	C-533	19.5	L-513	11.75

R. F. AMPLIFIER ALIGNMENT

<u>Band</u>	<u>Adjust Trimmers</u>	<u>At Freq. (MC)</u>
1	C-511, C-517, C-522	3.6
2	C-510, C-516, C-521	6.5
3	C-509, C-515, C-520	11.4
4	C-508, C-514, C-519	19.5

4. HETERODYNE OSCILLATOR ALIGNMENT.

Step a. Connect the signal generator test clip to the converter grid, pin No. 4 of V-502.

Step b. Adjust the generator to supply 3.6 megacycles modulated 30 per cent at 1000 cycles.

Step c. With the receiver dial set to 3.6 megacycles, align capacitor C-536 for maximum receiver output and reduce the signal input, keeping the receiver output below 5.5 volts during alignment of the trimmer, so as to prevent overloading.

Step d. Set the generator frequency to 2.05 megacycles and tune the receiver to this signal.

Step e. Adjust the oscillator inductance L-516 for maximum receiver output. This adjustment is controlled by a fillister-head screw on the back of transformer T-503. (See Figure 2-9).

Step f. Tune the receiver slightly both above and below 2.05 megacycles, adjusting L-516 at the same time until the simultaneous tuning and adjustment result in maximum receiver output.

Step g. Set the generator to 3.6 megacycles and repeat the operations in Step c. above.

Step h. Repeat the procedure of steps d to g

above until 3.6 megacycles is on frequency. This completes the alignment of the heterodyne oscillator on band 1.

Step i. Align the heterodyne oscillator on bands 2, 3 and 4 in accordance with the procedure described in Steps a. to h. above and Heterodyne Oscillator Alignment Table in this section, paragraph 3.

5. RADIO FREQUENCY AMPLIFIER ALIGNMENT.

Step a. Set the "ANT. COMP" control to + 5.

Step b. Attach the signal generator directly to the receiver "ANT" post, using a standard dummy antenna, and tune the signal generator to resonance with the receiver.

Step c. Adjust trimmer capacitors C-511, C-517 and C-522 in the order given, for maximum output. Reduce the signal input continuously to keep the receiver output below 5.5 volts, during alignment of the trimmers.

Step d. Align bands 2, 3 and 4 in accordance with the procedure described in Steps a. to c. immediately preceding, and in the R.F. Amplifier Alignment Table in this section, paragraph 3.

6. BEAT FREQUENCY OSCILLATOR ALIGNMENT.

Step a. Connect the generator test clip to pin No. 4 of the converter tube V-502.

Step b. Tune the generator to resonance with the receiver at approximately 1255 kilocycles and adjust the generator attenuator for a 2.4 volts receiver output.

Step c. Detune the signal generator both above and below 1255 kilocycles until the receiver output is reduced to 1.2 volts. Record the signal generator dial settings at these two points and set the generator dial to the average value.

Step d. Switch the "RECEPTION" control to "CW".

Step e. Replace the 600-ohm load with a pair of headphones.

Step f. Set the "BEAT NOTE" control exactly at zero.

Step g. Adjust the trimmer capacitor V-572 counterclockwise, from zero beat with the carrier to zero beat with the 1000 cycle modulation from the generator. A pulsing effect will be heard in the headphones when the amplitude of each 1000 cycle note is equal.

Step h. To check the alignment, take off the signal generator modulation. A 1000-cycle note should be heard in the headphones.

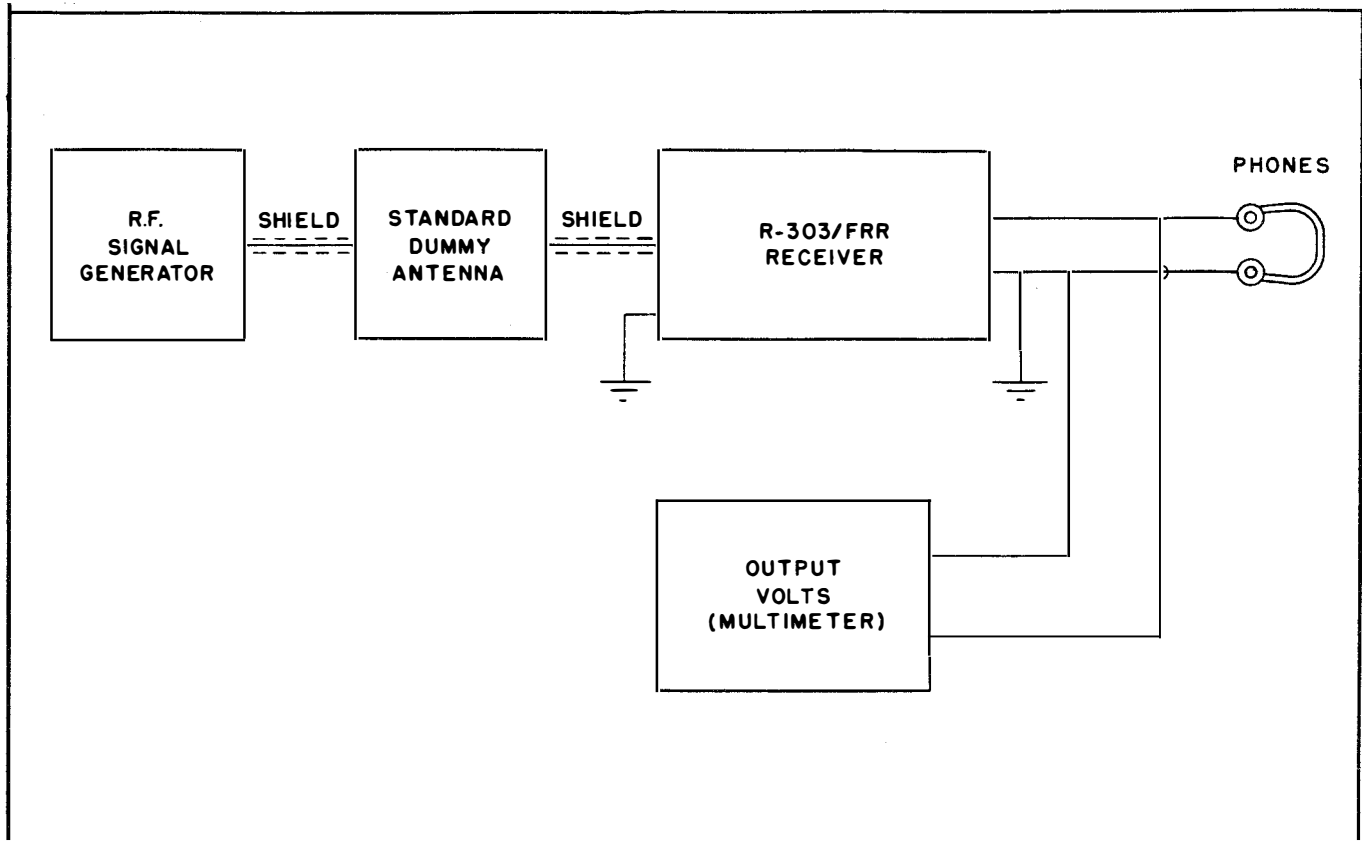

Figure 7-5. Test Assembly for Sensitivity Tests

(b) SENSITIVITY TESTS.

1. TEST LIMITS.—After the radio receiver has been restored to operation condition, and before any complete realignment is made, the sensitivity of the receiver should be measured for both C.W. and M.C.W. signals. The microvolts antenna signal input required to produce a reading of 1.9 volts across a 600-ohm non-inductive load resistor connected across the "PHONES" jack, J-503, is defined as the sensitivity of the receiver. The required microvolts should not exceed the values given in the following table:

<i>Band</i>	<i>Frequency (in megacycles)</i>	<i>Test Limits (in microvolts)</i>
1	2.0 — 3.6	8
2	3.6 — 6.5	8
3	6.5 — 11.4	15
4	11.4 — 20.0	25

2. SETTING UP RECEIVER FOR SENSITIVITY TESTS.

Step a. Connect a multimeter such a Multi-meter AN/PSM-4 Series, set up to measure volts, in parallel with 600-ohm headphones to the receiver "PHONE" jack, J-503.

Step b. Connect a standard Dummy Antenna to the receiver input. (For testing and alignment purposes, the Dummy Antenna is a substitute for the antenna system used in receiving communication signals.) See Figure 7-5.

Step c. Feed a signal from an R.F. signal generator to the Dummy Antenna.

Step d. At the high frequency end of the band being checked, adjust the "ANT COMP" control for maximum noise output as heard in the headphones.

Step e. Set the "SELECTIVITY" control to "BROAD".

Step f. Set the "BEAT NOTE" control to zero.

Step g. Set the "OUTPUT LEVEL" control to 100.

3. CHECKING M.C.W. SENSITIVITY.

Step a. Set "RECEPTION" control to "MOD".

Step b. Set "FREQ BAND" to the first band.

Step c. Set the signal generator to 3.6 mc. and modulate 30 per cent with 1000 cycles.

Step d. Tune receiver to 3.6 mc. Vary the tuning control so that needle on the multimeter deflects

maximum even though the tuning dial may not read precisely 3.6 mc.

Step e. Adjust the signal generator output to obtain a receiver output of 1.9 volts, measured on the multimeter connected across the headphones, with the receiver "GAIN" control set to 100.

Step f. Remove the modulation from the signal generator carrier. The residual output is noise from the receiver. If the noise level is less than 0.6 volts, then the signal generator microvolts reading is the measure of the receiver sensitivity. If the noise level is greater than 0.6 volts, as read on the multimeter connected across the headphones, continue as instructed in Steps g. to i. directly below.

Step g. Adjust the "GAIN" control until the noise level of the receiver output is 0.6 volts.

Step h. Turn the signal generator modulation on and adjust the attenuator until the receiver output is again 1.9 volts. (See Step e. of this paragraph.)

Step i. Turn off the modulation and see if the noise reading is still 0.6 volt. If the noise reading has changed, readjust the "GAIN" control until the noise level is again 0.6 volt.

Step j. Turn modulation on in the signal generator and adjust its output until the receiver output is again 1.9 volts.

Step k. Repeat Steps g. and h. until a signal to noise voltage ratio of 1.9 to 0.6 volts is obtained. The required signal generator output in microvolts is the measure of receiver sensitivity for M.C.W. reception.

Step l. Repeat for bands 2, 3 and 4 the Steps given from e. through h., setting the tuning controls to the high end of each band (compare with Steps c. and d.)

4. CHECKING C.W. SENSITIVITY.

Step a. Set "RECEPTION" control to "CW".

Step b. Set "FREQ BAND" to the first band.

Step c. Set "SELECTIVITY" control to "BROAD".

Step d. Tune the unmodulated signal from the signal generator to the high end of the first band of the receiver, which is 3.6 mc.

Step e. Set "BEAT NOTE" control on receiver to zero.

Step f. Set the tuning control of the receiver to 3.6 mc. Vary the tuning control so that the whistle heard in the headphones becomes lower in pitch and finally disappears.

Step g. Adjust the "BEAT NOTE" control until approximately 1000 cycles is heard in the headphones.

Step h. Remove the signal generator connection and short the input to the standard Dummy Antenna.

Step i. Adjust the "GAIN" control until the noise output of the receiver, as measured on the multimeter connected across the headphones, is 0.19 volt.

Step j. Remove the short from the standard Dummy Antenna, reconnect the signal generator, and adjust the generator attenuator to obtain a receiver output of 1.9 volts. The signal generator reading in microvolts is the measure of receiver sensitivity for C.W. reception.

Step k. Repeat for bands 2, 3 and 4, the Steps in this paragraph with corresponding settings of frequencies for the band involved. Always use the higher end of the band.

(2) MECHANICAL ADJUSTMENTS.

(a) MAINTENANCE AND REPAIR OF TUNING DIAL ASSEMBLY U-501.

1. GENERAL.—The tuning dial assembly is a precision mechanism, the parts of which are machined to extremely close tolerances. It has been carefully adjusted and aligned at the factory and, given reasonable care, should remain in proper adjustment over long periods of time.

Caution

Major adjustments and repairs to the dial mechanism should be made only by authorized members of maintenance personnel.

2. REMOVAL OF TUNING DIAL ASSEMBLY.—To remove the tuning dial assembly from the radio receiver proceed as follows:

Step a. Expose the receiver chassis by removing the dust cover. (Refer to section 6, paragraph 3b).

Step b. Remove the dial cover, calibration chart cover, and the type name plate from the front panel.

Step c. Remove all knobs from the front panel.

Step d. Remove all nuts on switches and other controls from the front panel.

Step e. Remove all screws securing the large name plate which covers the lower half of the panel.

Step f. Remove all panel mounting screws except one in each lower corner.

Step g. Set the band switch shaft to band 4. Remove the switch shaft through the R.F. transformer assemblies by releasing the spring on the rear of the oscillator transformer assembly and drawing the shaft toward the rear through the hole in the back of the chassis.

Note

On some receivers a set screw secures the band switch shaft to the band switch shaft coupling. (See Figure 6-1). Examine the coupling and if a set screw is present, loosen it before attempting to withdraw the shaft.

Step h. Unsolder the resistor R-501 from the ground connection behind the panel.

Note

Before unsoldering joints which have been treated with red tinted fungicidal lacquer, a suitable lacquer solvent should be used to remove the lacquer.

Step i. Remove the two screws on the front side of the ceramic coupling for the main tuning capacitor C-512. (See Figure 1-4).

Note

Follow the instructions in the preceding subparagraph above when replacing the original dial assembly. If a new dial assembly is to be installed, remove the taper pin in the ceramic coupling hub instead of removing the two screws from the ceramic coupling as in Step i. above.

Step j. Remove the "C" washers from the "ANT. COMP", "BEAT NOTE" and "SELECTIVITY" shafts and remove bushings.

Step k. Loosen the two lower corner screws of the panel and tilt the panel forward.

Step l. Remove the two upper screws which secure the dial assembly to the panel, and remove the dial assembly.

(b) INSTALLATION OF A NEW TUNING DIAL ASSEMBLY.—Installation of a new dial assembly is accomplished as follows:

Step 1. Mount the new dial assembly loosely on the panel by four screws (See Figure 4-2).

Step 2. Secure the panel to the chassis with at least four screws, one in each corner.

Step 3. Temporarily assemble the tuning knob to the dial drive and the band-switch shaft knob to the band switch shaft drive.

Step 4. Assemble the band-switch shaft, shift-

ing the dial to the proper position for location into the band-switch shaft coupling.

Step 5. Turn the tuning knob to determine the freeness of the capacitor gear shaft in the bushing of the ceramic coupling on the capacitor.

Step 6. When the proper location is determined Steps 4 and 5, tighten the four screws which secure the dial, then check the dial throughout its full rotation, examining the point of coupling for binding. With the detent spring (58) removed from the two arms (59), check the band-switch shaft throughout its full rotation for freeness. (See Figure 7-22).

Step 7. Replace the detent spring and assemble a set screw to the ceramic coupling on the capacitor.

Step 8. Remove the covers from the main tuning capacitor.

Step 9. Set the dial to "O", and, with a .007" shim between the capacitor rotor stop and the top of the stator plates, tighten the set screw in the ceramic coupling.

Step 10. Drill and ream the coupling bushing midway between the set-screw hole and the existing pin hole, using a No. 48 drill and a 5/0 taper reamer. Pin and remove the set screw.

Step 11. Using the pilot holes in the panel, drill two holes in the front plate (46) of the dial assembly with a No. 48 drill. (See Figure 7-10).

Step 12. Drive two straight pins into the front plate below, flush to panel.

Step 13. Remove the two lower screws holding the dial and replace all panel screws. Apply glyptal to all screws not secured by nuts.

Step 14. Tighten the bushings and replace the "C" washers on "ANT. COMP", "BEAT NOTE" and "SELECTIVITY" shafts.

Step 15. Reassemble the name plates, controls and knobs, applying glyptal to all nuts securing switches and controls, as well as to set screws and nameplate screws.

Step 16. Attach and solder resistor R-501 to the ground connection. Apply fungicidal lacquer to the joint.

(c) TYPICAL REPAIR OF TUNING DIAL MECHANISM. (See Figure 7-22).

1. REPLACEMENT OF VERNIER IDLER GEAR.—The following instructions for the replacement of the vernier idler gear (9) constitutes a typical repair procedure for the mechanism of the tuning dial assembly U-501. (See Figures 4-2 and 6-1).

Step a. Assemble a set screw into the hub of dial pinion gear (47).

Note

There are two identical dial pinion gears, both designated by index number 47. The set screw is assembled into the one riding on the capacitor drive gear (28) and this particular gear will hereafter be referred to as the capacitor pinion gear.

Step b. Remove the taper pin (32) in the collar (43) and the taper pin (45) in the dial-lock hub (44).

Step c. Remove the pin (12) in the capacitor pinion gear.

Step d. Remove the three screws (26) holding the rear plate (63) to the front plate (46).

Step e. Set the dial (42) to "0" and the masking plate (40) to band 1. Clamp the stop arm (66) to prevent rotation of the driver shaft.

Step f. Separate the rear plate (63) from the front plate (46).

Step g. Loosen the set screw on the capacitor pinion gear.

Step h. Remove the dial pinion gear and its shaft assembly from the rear plate. Apply tension to the teeth of the vernier idler gear (49) when passing through the teeth of the dial drive gear (56).

Step i. Obtain a new shaft to replace the vernier idler shaft (48), a new gear to replace the vernier idler gear (49) and a new gear to replace the dial pinion gear (47). Assemble the gears (49 and 47) in their approximate positions with set screws.

Step j. Assemble the spring washer (52) over the shaft (48) and assemble the shaft to the rear plate, placing tension of two teeth on the dial drive gear (56). Oil the bearing surfaces with lubricant conforming to Navy Spec. 14-0-20 (ORD).

Step k. Place the washer (24) over the detent shaft (31) and assemble the capacitor pinion gear (47) with a set screw.

Step m. With the vernier and dial set to "0" and the masking plate centered to band 1, position the rear plate (63) with respect to the front plate (46). Place tension of one tooth on the dial gear (7), and tension of half a tooth on the vernier idler gear (49). Adjust the position of the capacitor pinion gear (47) on the vernier idler shaft (48) so that the base of chamfer on the shaft is flush with the outside face of the hub. Check the alignment of the capacitor pinion gear with the capacitor drive gear (28). Align the

vernier idler gear with the vernier gear (11) so that their rear surfaces are flush. Align the dial pinion gear (47) with the dial gear (7) so that both teeth of the dial gear ride equally on the dial pinion gear.

Step n. Release the clamp, referred to in the preceding step e. and assemble the three screws (26) to hold the rear plate (63) to the front plate (46). Check all gears for alignment throughout their full rotation.

Step o. Check the position of the stop pin (65) on the long stop arm (66). If the stop arm does not hit the pin and its hub at the same time, shift the position of the capacitor pinion gear. The dial must check on "0". If this is not correct shift the position of the dial pinion gear. Check alignment of gears as instructed in preceding steps m. and n.

Step p. Replace the collar (43) and the dial lock-hub (44). Drill, ream and pin the collar and hub, using a No. 48 drill and a 5/0 tapered reamer.

Step q. Drill, ream and pin the three gears, using a No. 52 drill and 6/0 tapered reamer.

Caution

If the old collars and gears must be used, drill a new pin hole in the gear midway between the set screw hole and the existing pin hole.

Step r. Remove all set screws and apply glyptal to all replaced pins.

Step s. Check for smoothness of operation and gear alignment.

2. FREQUENCY BACKLASH.—Frequency backlash or mechanical backlash in the gears, is the result of improper adjustment or misalignment of the tuning dial mechanism. To check the mechanism for this condition use a beat frequency oscillator. Tune to zero beat in one direction and then in the opposite direction. The difference in readings on the vernier scale should not be greater than one-half of one scale division. If this requirement is not met, this faulty condition can be remedied by completely re-oiling all bearings with lubricant conforming to Navy Specifications 14-0-20 (ORD), working the oil well into the bearing surfaces, checking all gear springs for proper tension, and checking all taper pins for tight fit. If any spring appears weak, replace it with a new one from the spare parts. If any taper pin is loose when checked for torque strain, redrive it (making sure the hub is firmly supported). If the backlash condition is not remedied after redriving, replace the defective pin.

8. COIL WINDING DATA.—The coil winding data consists of information helpful to the technician when new coils are to be prepared.

COIL DATA

Symbol Designation	See Fig. No.	Winding	Type of Winding	Wire Size	Turns	Number of Turns To Tap	Cam	Driver Gear	Driven Gear	D.C. Resist. in ohms	Inductance in microhenries, 1000 cycles	Q information		See Note	Pri. coil loaded with	
												Frequency in Mega-cycles	Capacity in microfarads			
L-501	7-6-A	PRI. SEC.	universal spaced solenoid	#36SSE #20 silver	28½ 8		.062	72	35	2.17 0.002	23 less than 1 20.0 11.5 73.5 222 79 52	1,5	400 ohms
L-502	7-6-B	PRI. SEC.	universal spaced solenoid	#36SSE #24E	31½ 14½		.062	72	35	2.3 0.083	27.5 2 11.5 6.5 70 220 110 65	1,5	400 ohms
L-503	7-6-C	PRI. SEC.	universal close solenoid	#36SSE 19-44 Litz	78½ 28		.062	72 73	35 50	6.23 0.73	168 10 6.5 3.6 65 217 60 50	2,5	400 ohms
L-504	7-6-D	PRI. SEC.	universal universal	#38SSE 30-44 Litz	144 37		.125 .157	37 71	36 30	17.8 0.83	532 32 3.6 2.0 56 195 50 75	4,5	200 MMF
*L-505 *L-509	7-6-E	PRI. SEC.	close solenoid spaced solenoid	#28E #20 soft silver	⅔ 8		0.014 0.018	less than 1 less than 1 20 11.5 65 220 168 130	1,3,5,6	
L-506 L-510	7-6-F	PRI. SEC.	close solenoid spaced solenoid	#28E #24E	1⅔ 14⅓		0.027 0.066	less than 1 3 11.5 6.5 67.6 216 145 120	1,3,5	

NOTES

1. Start at bottom hole and wind all except 1 turn in groove then cross over two grooves and wind the last turn to hole in coil form.
2. Start at hole and wind all except 1 turn then skip approximately 3/32" and wind last turn to hole on coil form.
3. Wind primary between holes.
4. Bring tap lead through hole to terminal. Do not twist.
5. Vacuum impregnate with an approved fungicidal wax by an approved process.
6. *L-509 is identical to L-505 except for "Q Information" which is as follows

	f	Cap	Q
	20	71	162
	11.5	217	125

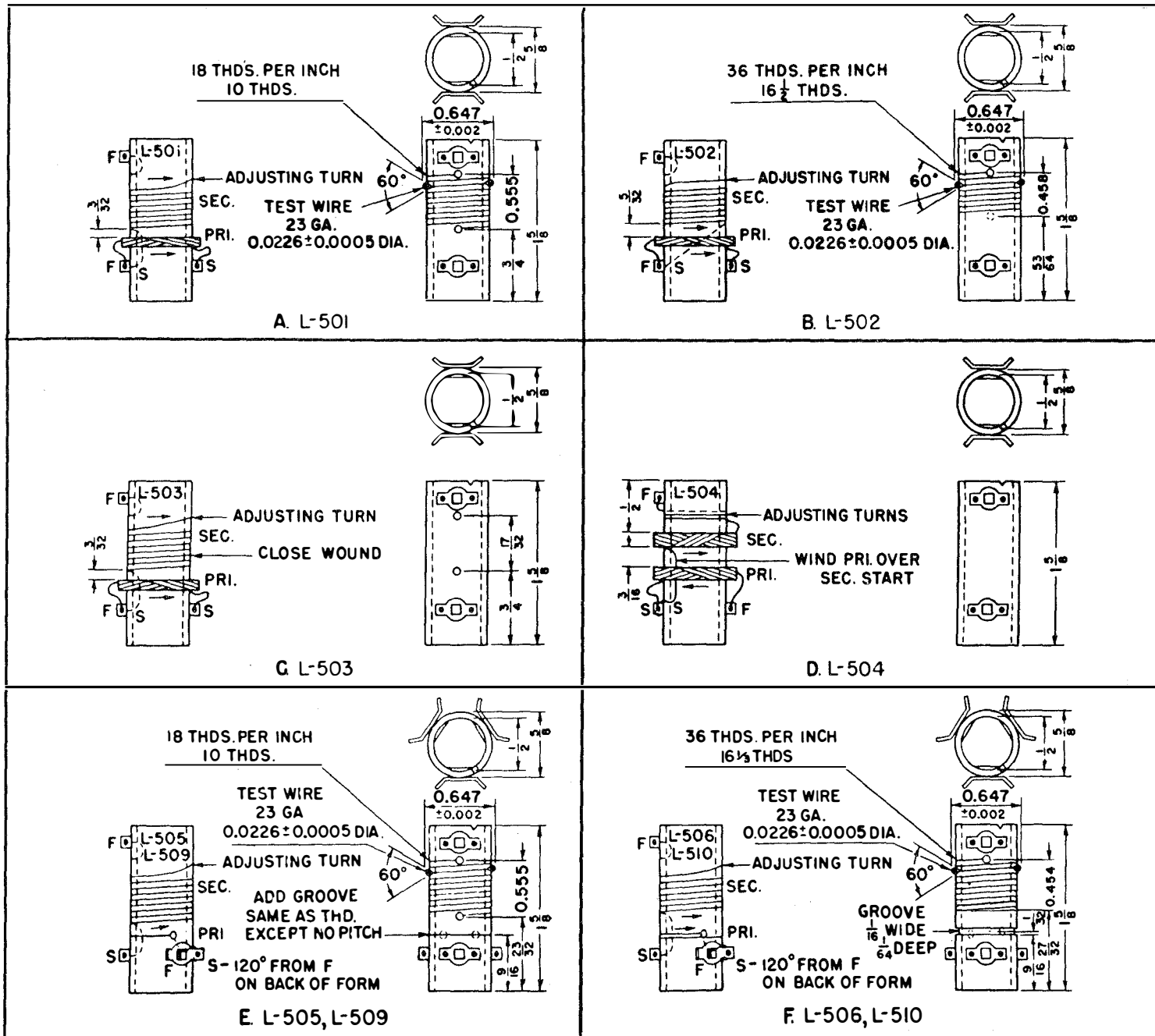

Figure 7-6. Coil Winding Diagrams.

COIL DATA

Symbol Designation	See Fig. No.	Winding	Type of Winding	Wire Size	Turns	Number of Turns To Tap	Cam	Driver Gear	Driven Gear	D.C. Resist. in ohms	Inductance in microhenries, 1000 cycles	Q information		See Note	Pri. coil loaded with
												Frequency in Mega-cycles	Capacity in microfarads		
L-507 L-511	7-7-A	PRI.	close solenoid	#32E	2 $\frac{2}{3}$		0.088	less than 1	
		SEC.	universal	30-44 Litz	21		.157	71	30	0.38	10	6.5 3.6	59 205	52 77	3,5
L-508 L-512	7-7-B	PRI.	close solenoid	#32E	4 $\frac{2}{3}$		0.135	less than 1	3,5,7
		SEC.	universal	7-41 Litz	38		.157	62	66	1.21	31	3.6 2.0	50 185	52 80	
L-513	7-7-C	single	spaced solenoid	#24E	7 $\frac{1}{2}$	2 $\frac{1}{2}$ 5	0.050	less than 1	20.0 11.5	88 270	107 85	1,4,5,6
L-514	7-7-D	single	spaced solenoid	#24E	13 $\frac{1}{2}$	3 $\frac{1}{2}$ 10	0.082	2	11.5 6.5	85 267	133 105	1,4,5,6
L-515	7-7-E	single	spaced solenoid	#24E	25 $\frac{1}{4}$	7 $\frac{1}{2}$ 15	0.133	7.5	6.5 3.6	104 344	132 104	1,4,5 6
L-516	7-7-F	single	close solenoid	#30E	34 $\frac{1}{2}$	9 $\frac{1}{2}$ 15	55	48	0.75	18	3.6 2.0	130 425	65 55	2,4,5 6

NOTES

1. Start at bottom hole and wind all except 1 turn in groove then cross over two grooves and wind the last turn to hole in coil form.
2. Start at hole and wind all except 1 turn then skip approximately 3/32" and wind last turn to hole in coil form.
3. Wind primary between holes.
4. Bring tap lead through hole to terminal. Do not twist.
5. Vacuum impregnate with an approved fungicidal wax by an approved process.
6. Remove wax from mounting holes.
7. *L-512 is identical to L-508 except for "Q Information" which is as follows

<i>f</i>	<i>Cap</i>	<i>Q</i>
3.6	51	51
2.0	188	82

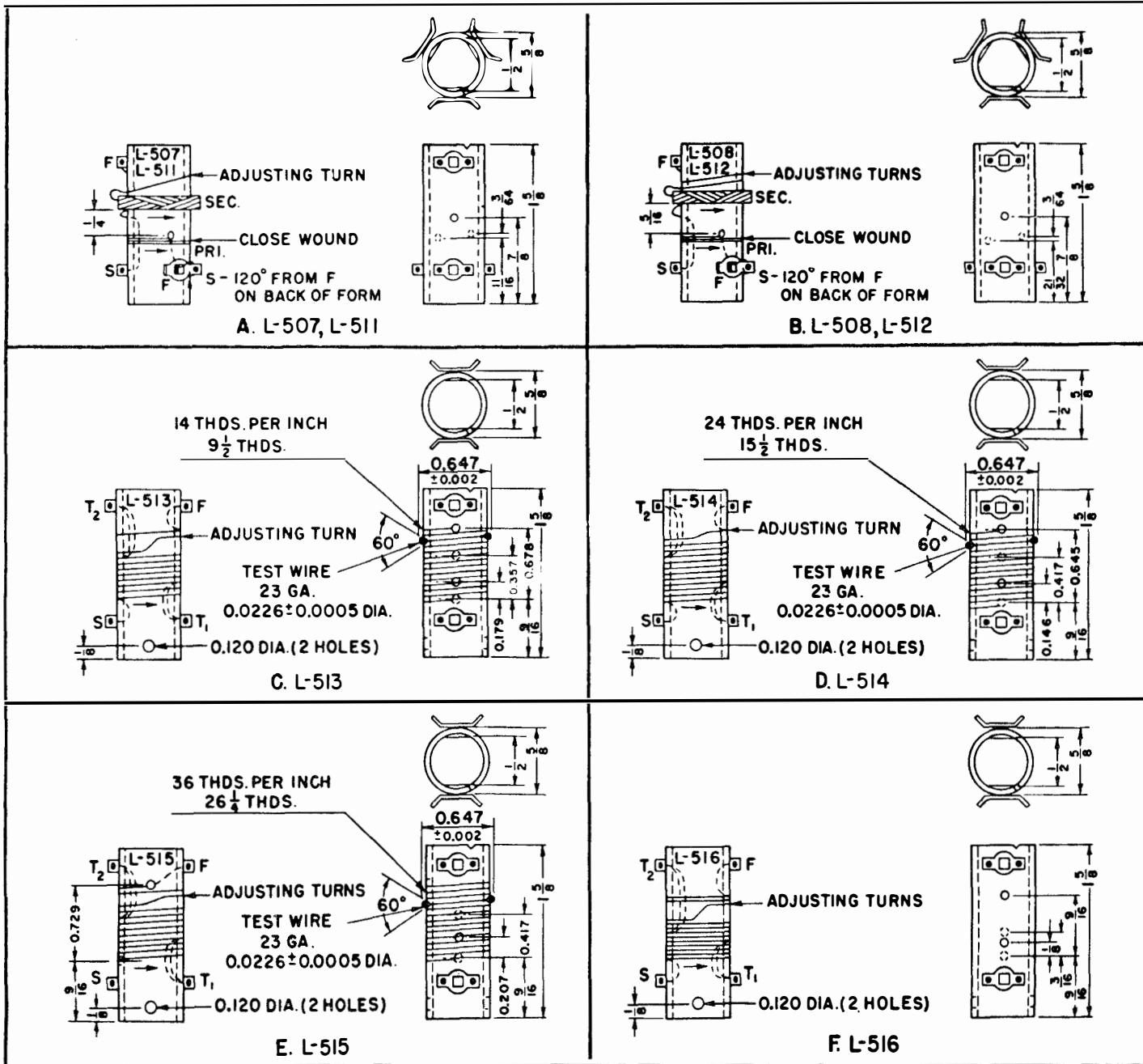

Figure 7-7. Coil Winding Diagram.

COIL DATA

Symbol Designation	See Fig. No.	Winding	Type of Winding	Wire Size	Turns	Number of Turns To Tap	Cam	Driver Gear	Driven Gear	D.C. Resist. in ohms	Inductance in microhenries, 1000 cycles	Q information		See Note	Pri. coil loaded with
												Frequency in Megacycles	Capacity in microfarads		
L-517	7-8	PRI.	universal	30-44	45/45		.157	62	24	1.52	108	1.250	147	135	1,2,3,5
		SEC.	universal	Litz 30-44	45/45	45	.157	62	24	1.48	111	1.250	143	135	
		TERT.	random	Litz 36DCC	6½						0.43				
L-518	7-9	PRI.	universal	30-44	45/45		.157	62	24	1.49					1,2,3,5
		SEC.	universal	Litz 30-44	45/45	45	.157	62	24	1.53	113	1.250	142	138	
		TERT.	random	Litz 36DCC	6½						0.43				
L-519	7-10	PRI.	universal	30-44	45/45		.157	62	24	1.49	108	1.250	147	138	2,3,5
		SEC.	universal	Litz 30-44 Litz	45/45	68	.157	62	24	1.47	111	1.250	143	138	
L-520	7-11	single	universal	36DCC	34/34	12½	.157	71	30	5.75	75	1.50 0.90	149 416	74 59	4

NOTES

1. Wind tertiary (tert.) winding in groove.
2. All leads 1¼" long skin and tin ½".
3. Vacuum impregnate with an approved fungicidal wax by an approved process.
4. Vacuum impregnate with an approved fungicidal lacquer by an approved process. The lacquer should be thinned with toluol to a specific gravity of approximately 0.93 at 24° C.
5. Remove wax from mounting holes.

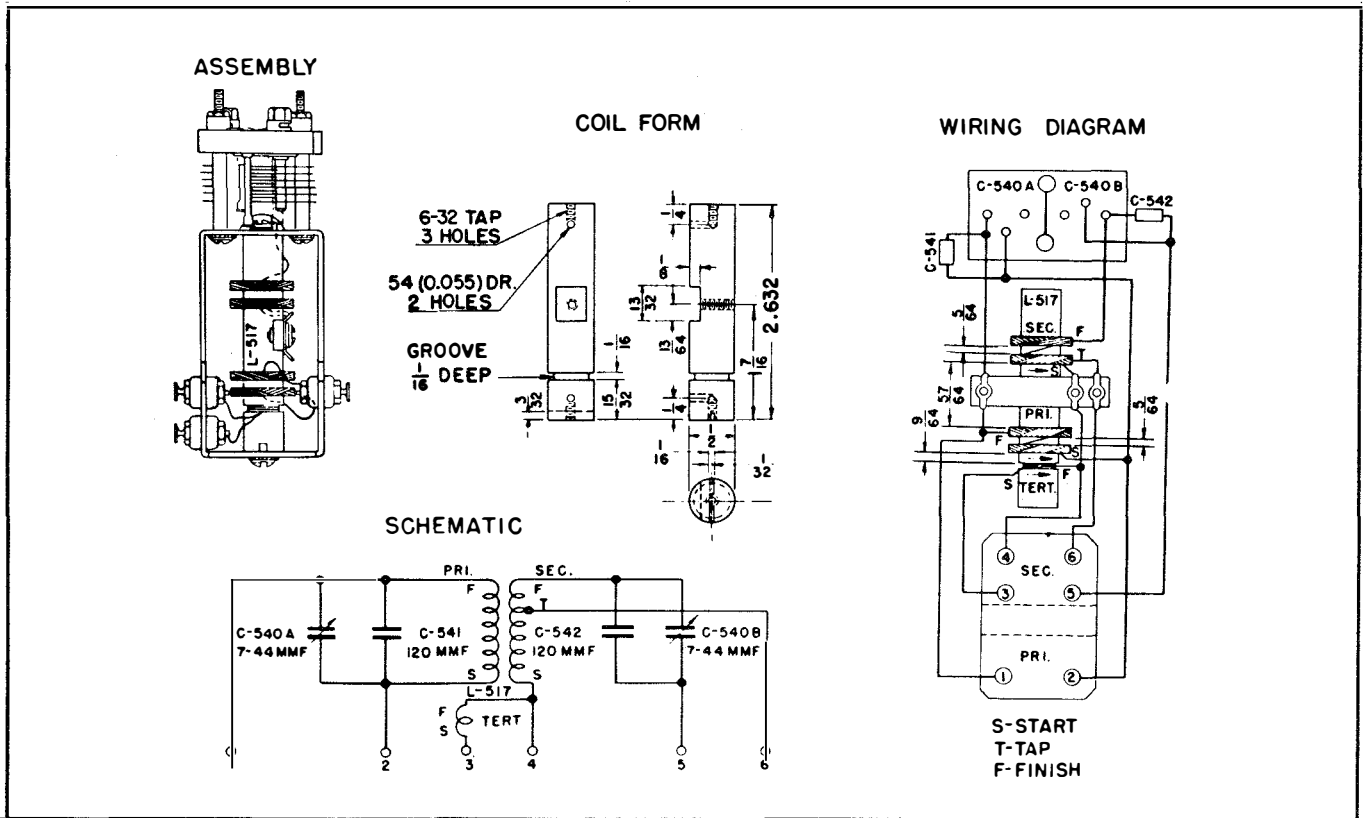

Figure 7-8. 1st I.F. Transformer Details

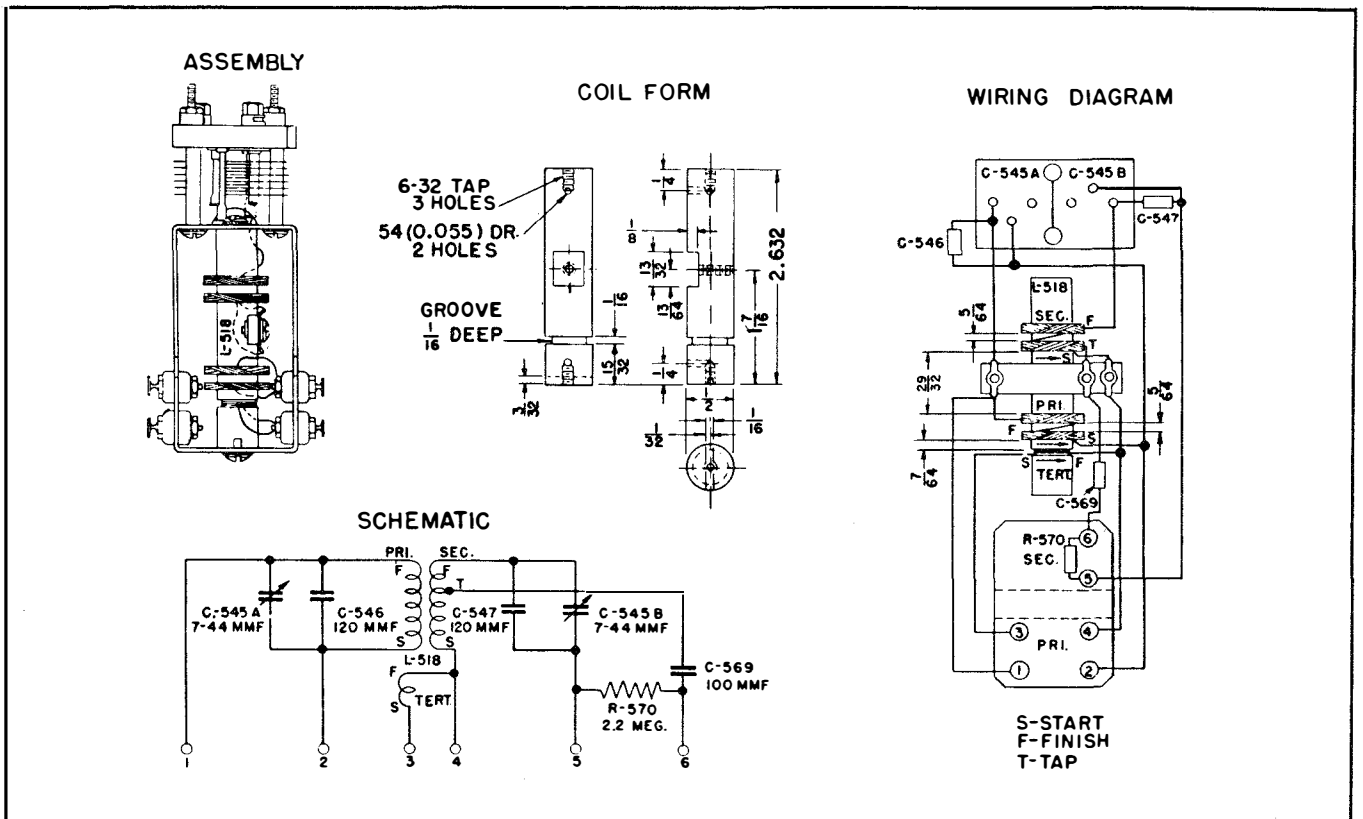

Figure 7-9. 2nd I.F. Transformer Details

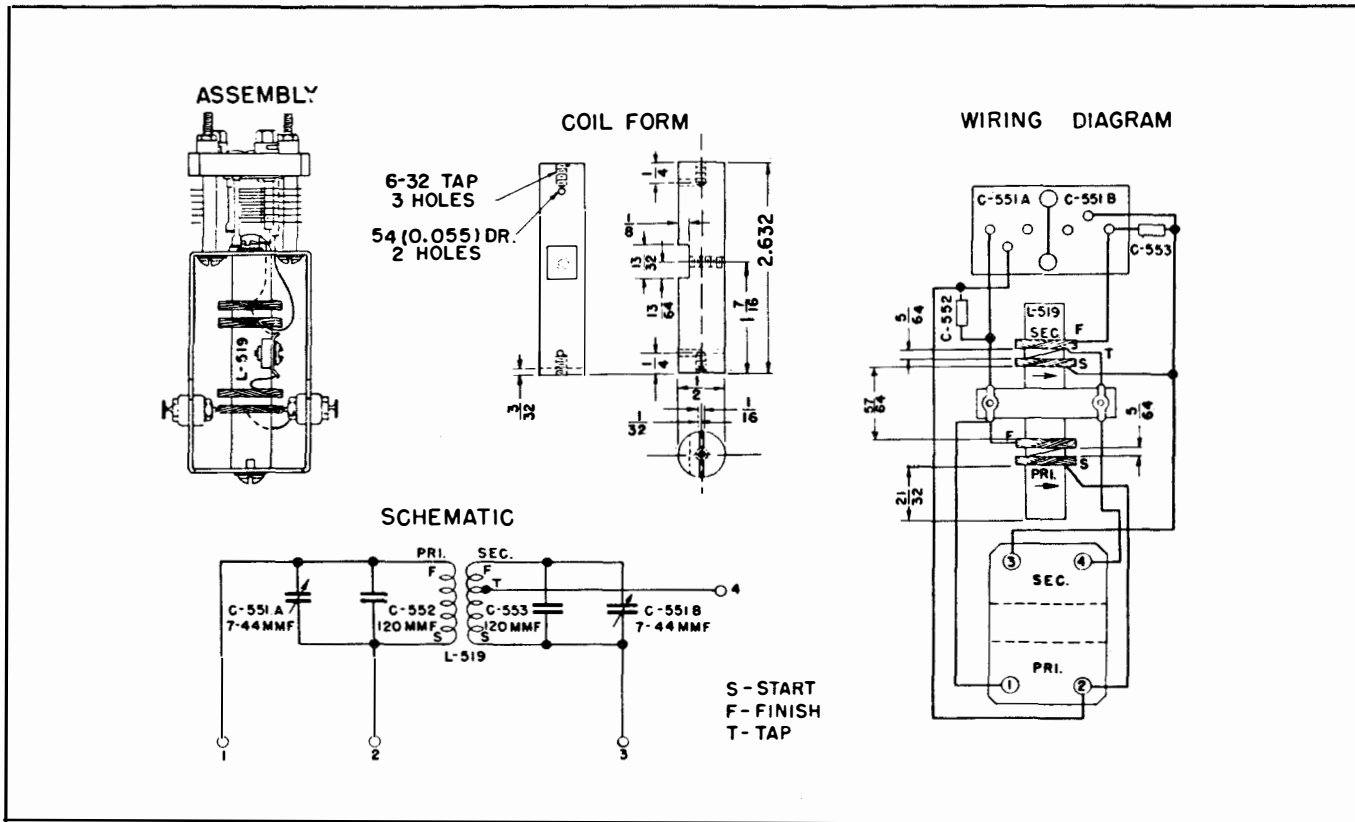

Figure 7-10. 3rd I.F. Transformer Details

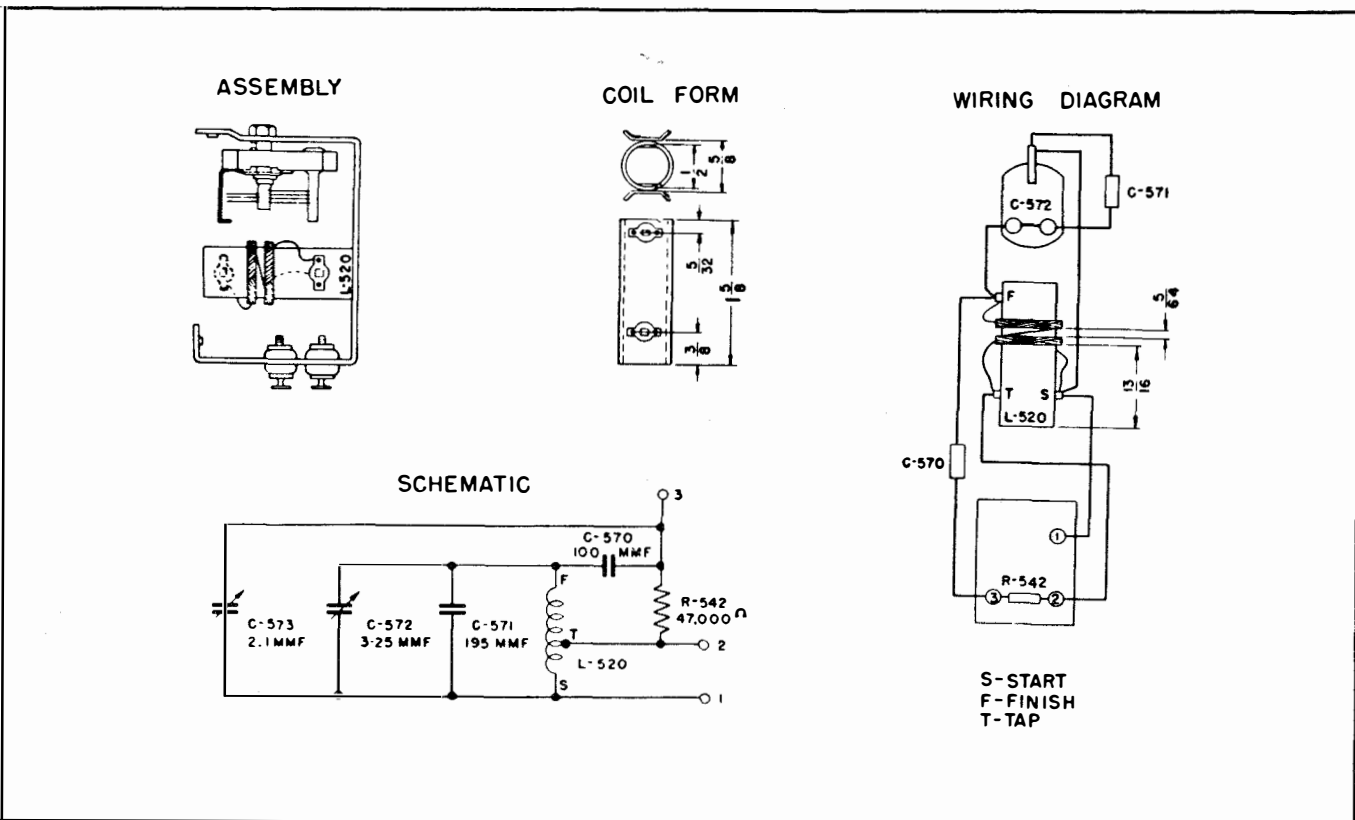

Figure 7-11. B.F.O. Transformer Details

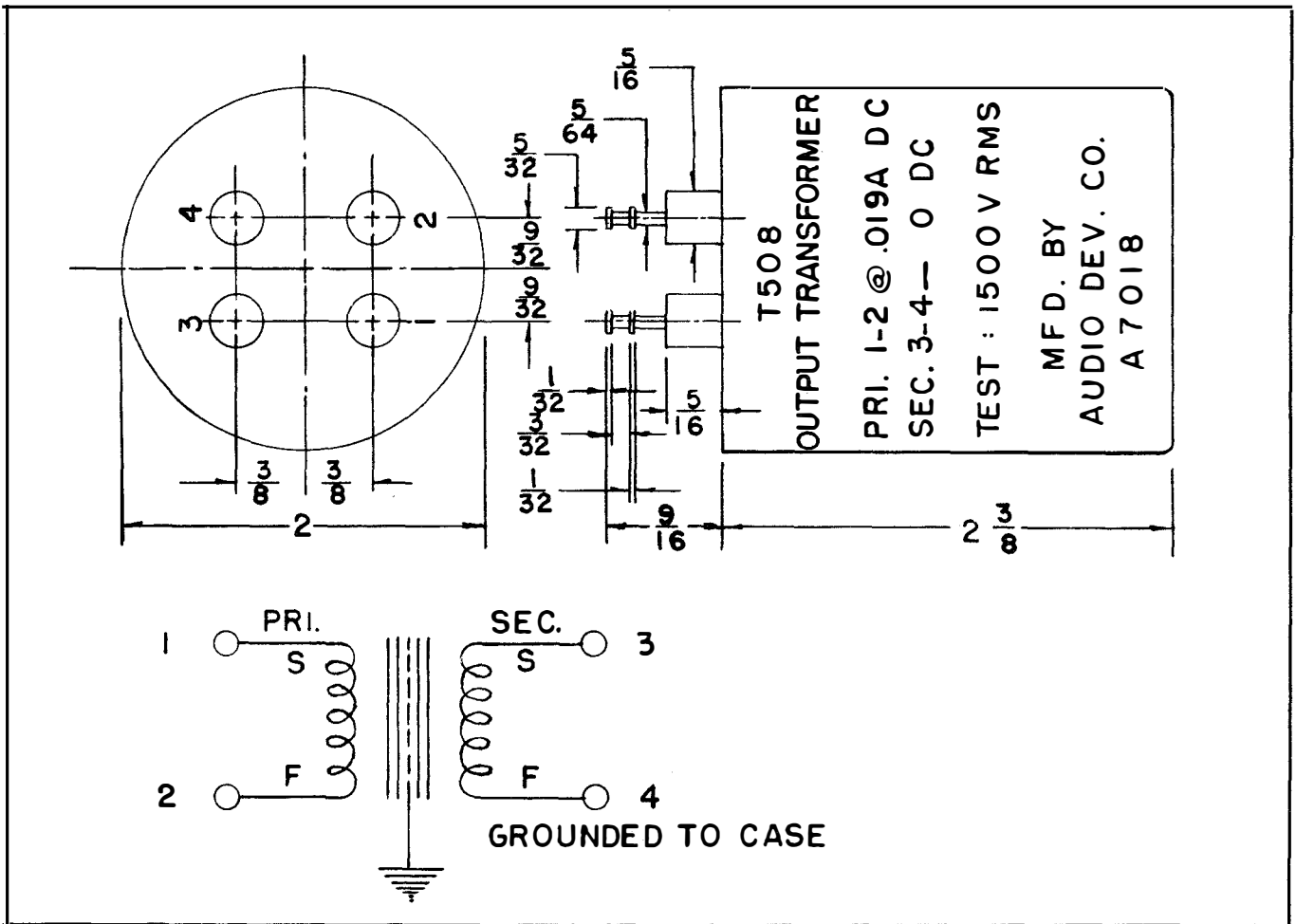

Figure 7-12. Receiver Output Transformer, T-508

	<u>PRIMARY</u>	<u>SECONDARY</u>
Turns:	3000	784
Taps:	—	—
T/Layer:	144	80
Wire Size:	38 en	33 en
No. of Layers:	21	10
Lead Wire Colors:	S-1 Yellow F-2 Green	S-3 Blue F-4 Black
Tube Size	5/8" x 5/8"	
Layer Ins.:	0.0007 Glassine	0.001 Glassine
Wrapper:	2 layers 0.005 Kraft	1 layer 0.005 Kraft 1 layer 0.005 gummed Kraft
Core Stack and Thickness:	5/8 — 0.014"	
Test Volts:	1500 V RMS	1500 V RMS
DCR:	567 ohms ±15 o/o	56 ohms ±15 o/o
Test:	L ₁₋₂ = 7 henrys min.	at 5V — 1000 cps., 0.0185 A. DC

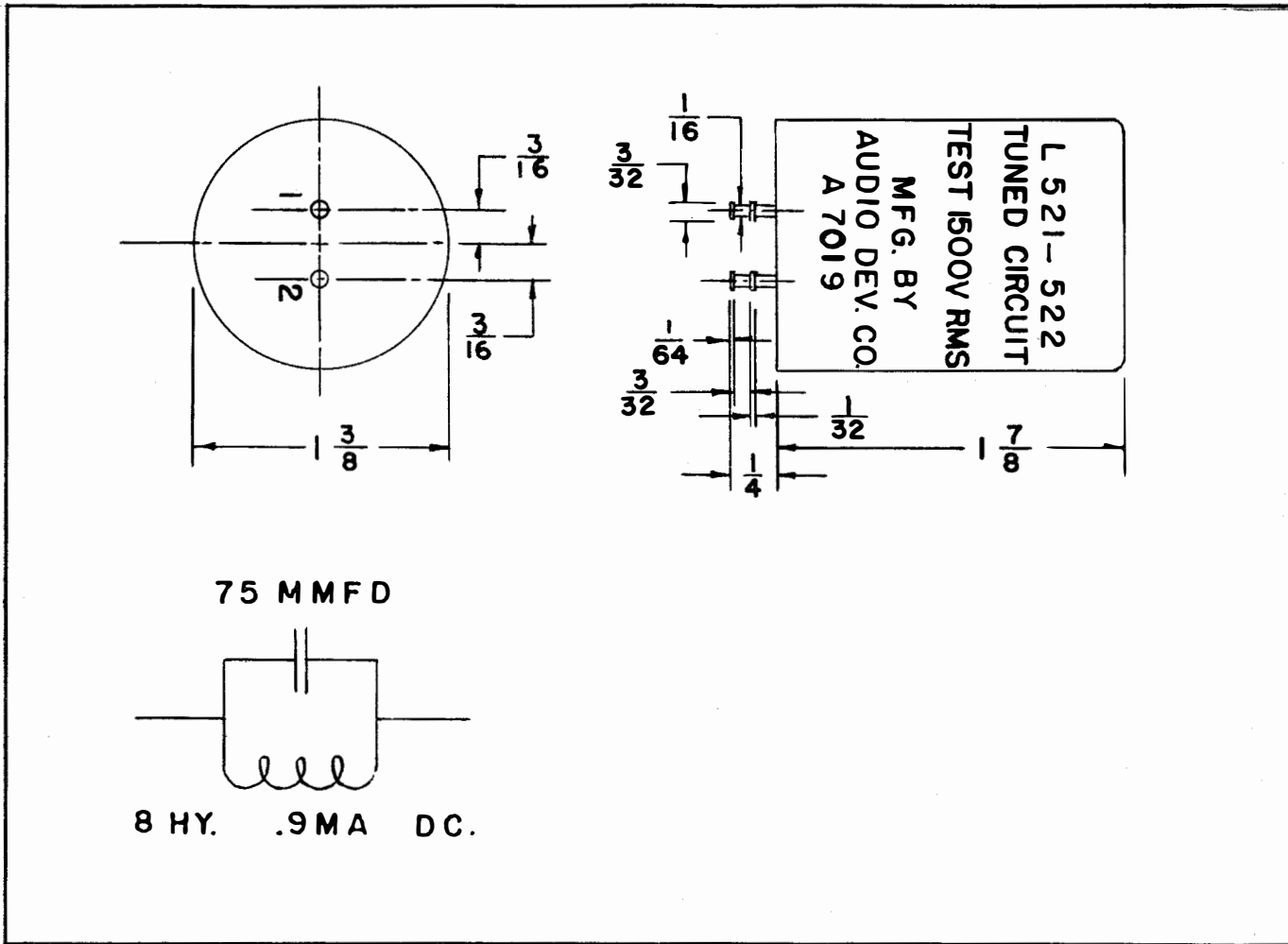

Figure 7-13. Low Pass Filter Reactor, L-521

Turns:	7340 in parallel with 75 mmf. condenser
Taps:	—
Wire Size:	No. 42 en
T/L:	165
No. of Layers:	45
Lead Wire Colors:	S — 1 Brown F — 2 Red
Tube Size:	7/16" x 3/8"
Layer Ins.:	0.0005 Kraft
Wrapper:	1 L 0.007" Flatback Type ± 1 L 0.005 Gummed Kraft
Core Stack and Thickness:	3/8" — 0.007"
Test Volts:	1500 V RMS
Test:	Tuned to series resonance with 75 mmf., 500V, mica condenser at 6500 cps ±3 o/o.

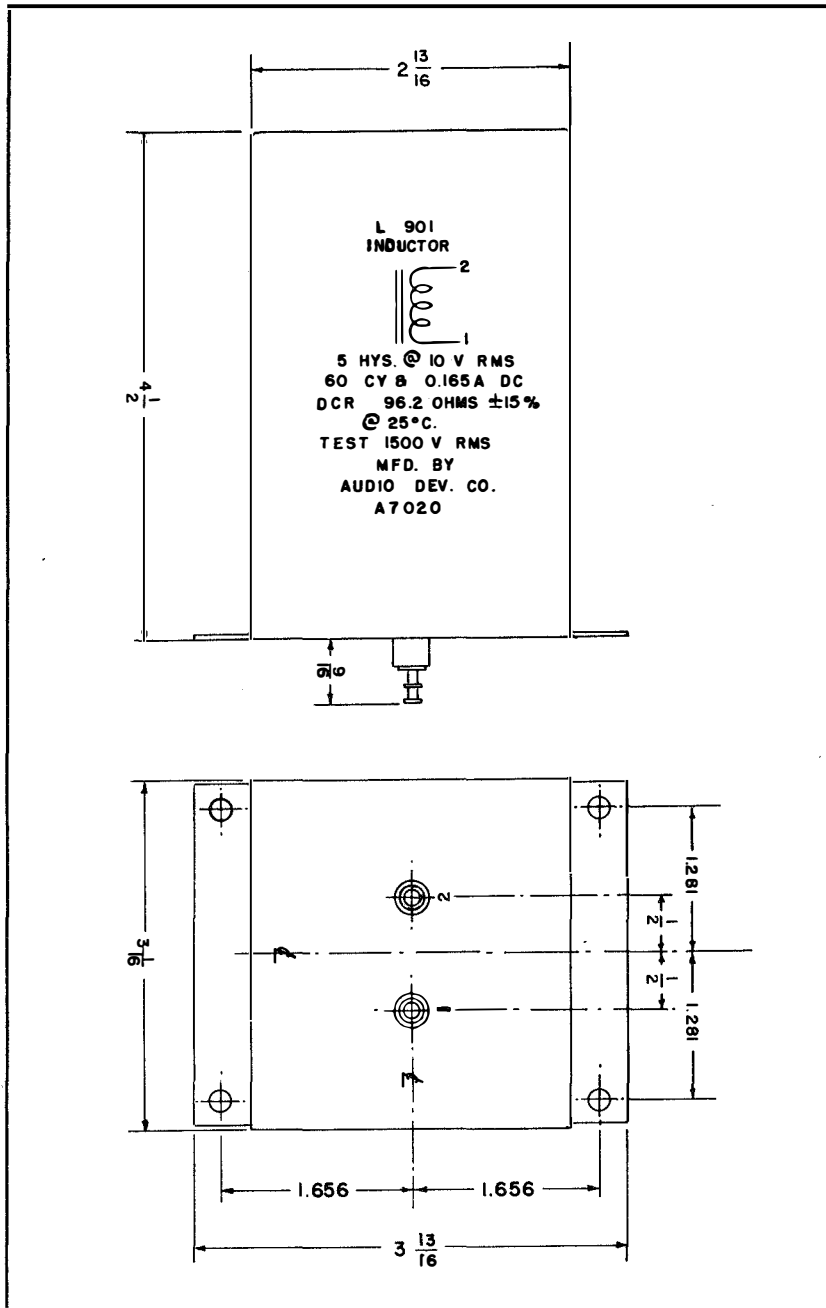

Figure 7-14. Power Supply Filter Choke, L-901

Turns:	2460
Taps:	—
Wire Size:	No. 29 en.
T/Layer:	88
No. of Layers:	28
Lead Wire Colors:	S — 1 Black F — 2 Red
Tube Size:	1" — 1"
Layer Ins.:	0.0015 Glassine
Wrapper:	3 layers 0.005 Kraft 2 layers 0.005 K 1 layer 0.005 GK
Core Stack and Thickness:	1" — 0.019"
Test Volts:	1500 V RMS
DCR:	96.2 ohms ±15 o/o at 25°C
Test:	L = 5 hys min at 10 V 60 cps 0.165 A. DC

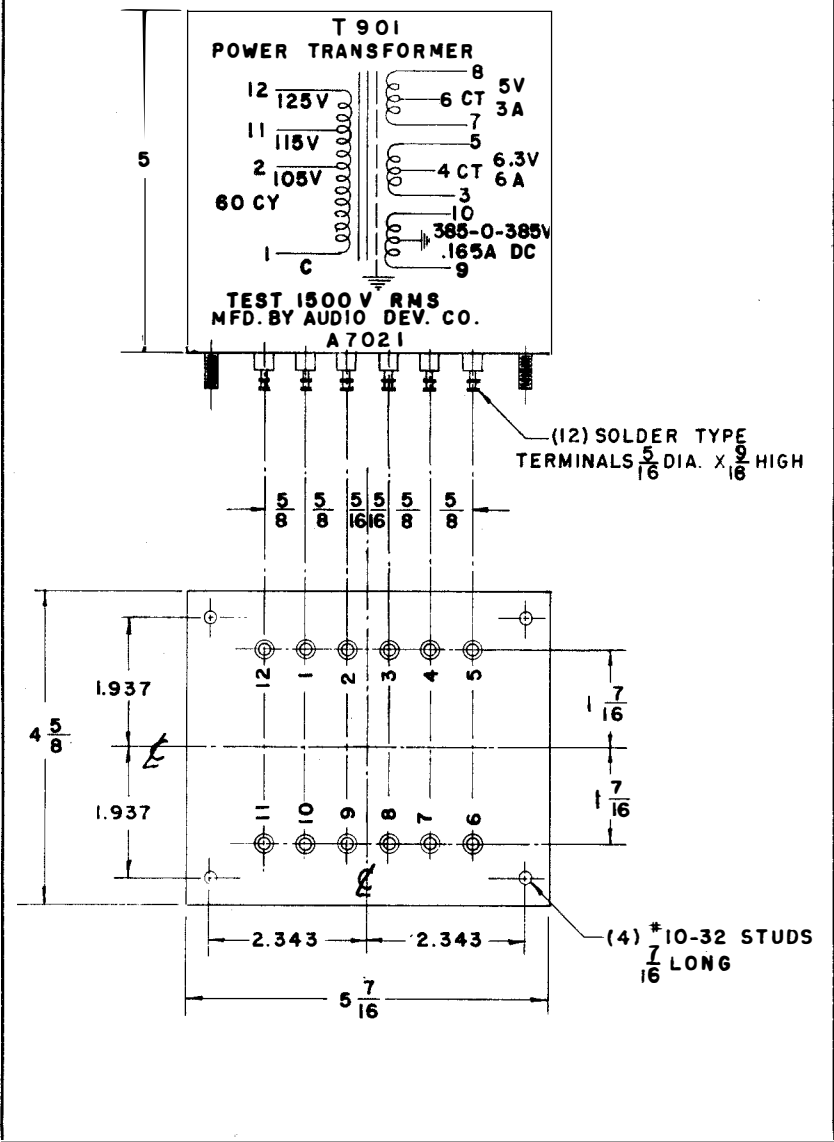

Figure 7-15. Power Supply Transformer, T-901

	<u>PRIMARY</u>	<u>SECONDARY 1</u>	<u>SECONDARY 2</u>	<u>SECONDARY 3</u>
Turns:	261	1671	14	11
Taps:	220V 240½	835½V	7V	5½
Wire Size:	No. 20 en.	No. 28 en.	(2) No. 15 en.	(2) No. 18 en.
T/Layer:	48	120	14	11
Layers:	6	14	1	1
Lead Wire Colors:	S — 1 BK T — 2 BK-R T — 11 BK-Y F — 12 OR	S — 9 R T GND F — 10 BL	S — 3 GR-Y T — 4 R-Y F — 5 GR-Y	S — 7 GR T — 6 BL-Y F — 8 GR
Tube Size:	1½" x 2⅛"			
Layer Ins.:	0.003" Glassine	0.0015" Glassine	—	—
Wrapper:	3 layers 0.005 Kraft	3 layers .005 Kraft	2 layers 0.007 Fiberoid	2 layers 0.007 F and 1 layer .005 Gummed
Core Stack and Thickness:	2⅛" — 0.019			
Test Volts:	1500 V RMS	1500	1500	1500
Test:	Maximum core loss = 7.5 watts 1 power factor = 80 o/o min. between 103.5V and 126 V line with Secondary 1 loaded with 24 ma. and Secondary 2 loaded at 1.8A at 115V line.			

NAVSHIPS 91944
RBS-3

CORRECTIVE
MAINTENANCE

ORIGINAL

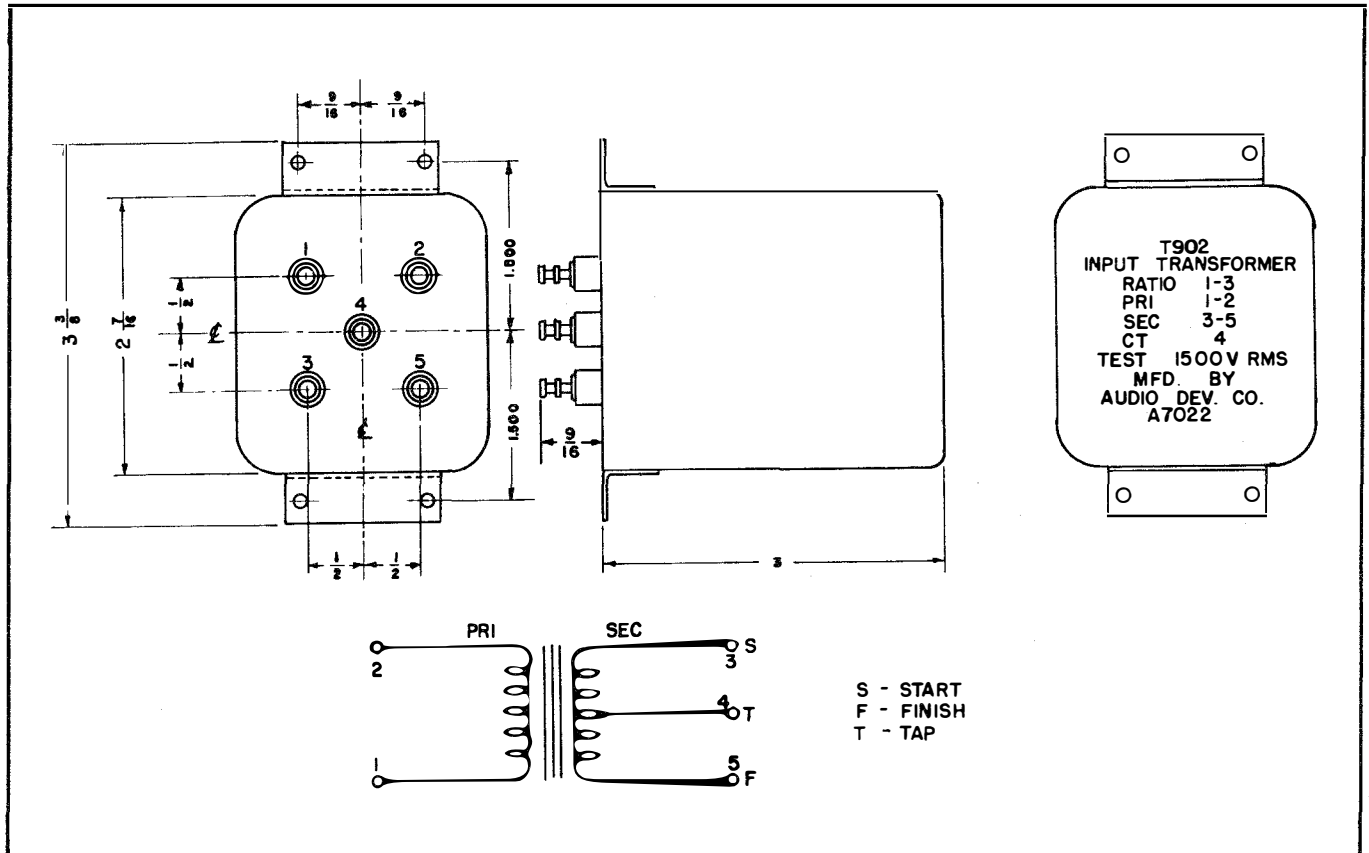

Figure 7-16. Input Transformer, T-902

	<u>PRIMARY</u>	<u>SECONDARY</u>
Turns:	550	1650
Taps:	—	825
Wire Size:	No. 32 en.	No. 35 en.
T/Layer:	75	104
Layers:	8	16
Lead Wire Colors:	S — 1 Black F — 2 Blue	S — 3 Green T — 4 Yellow F — 5 Red
Tube Size:	5/8" x 5/8"	
Layer Ins.:	0.0015 Glassine	0.001 Glassine
Wrapper:	2 layers 0.005 Kraft	1 layer 0.005 Kraft and 1 layer 0.005 Gummed Kraft
Core Stack and Thickness:	5/8 — 0.014"	
Test Volts:	1500 V RMS	1500 V RMS
DCR:	25 ohms ± 15 o/o	170 ohms ± 15 o/o
Test:	Voltage Ratio = 1 — 3 at 3V — 1000 cps. L ₁₋₂ = 2.5 hys. min. at 10V — 60 cps.	

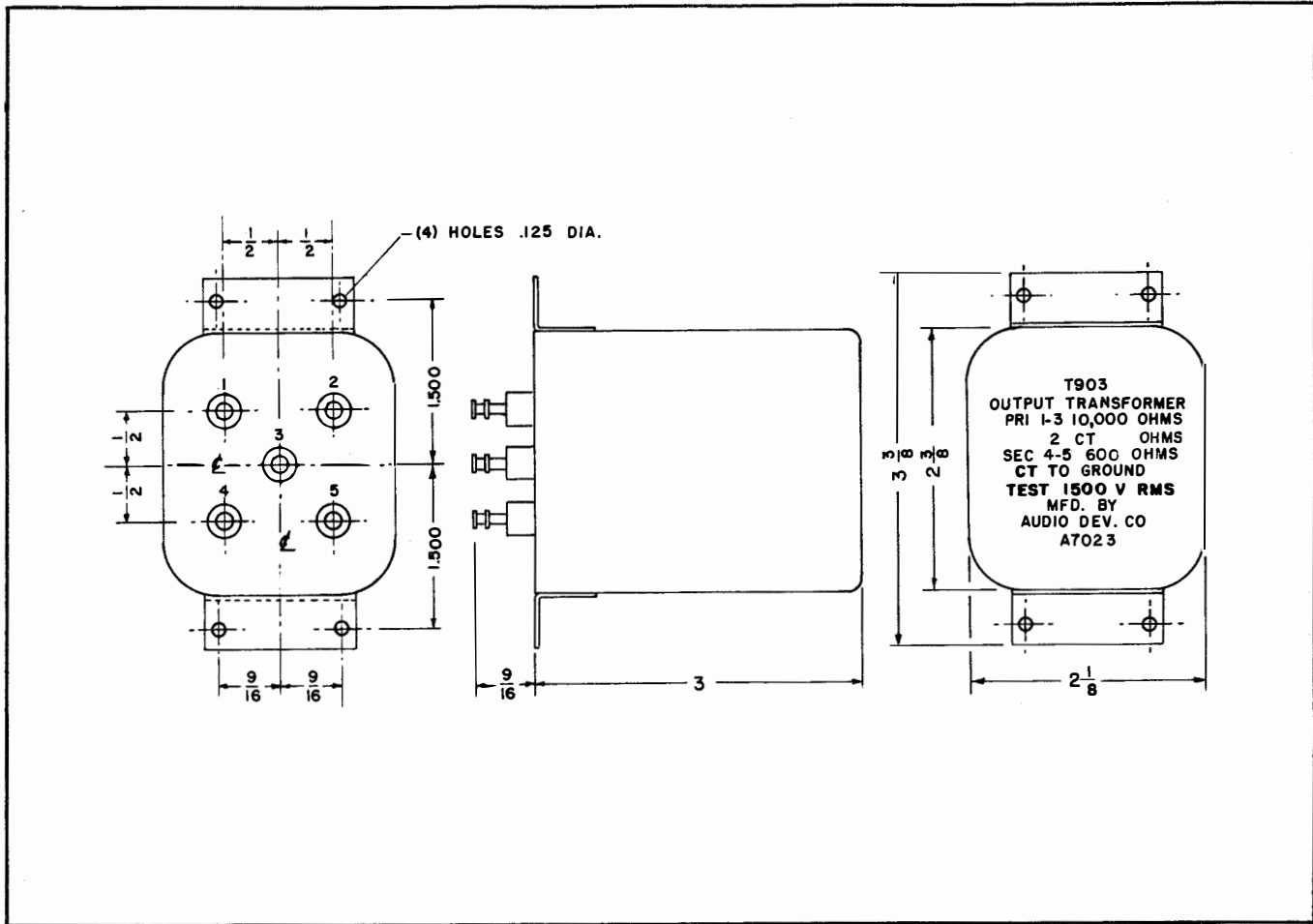

Figure 7-17. Output Transformer, T-903

	<u>PRIMARY</u>	<u>SECONDARY</u>
Turns:	2226	550
Wire Size:	No. 35 en.	No. 34 en.
Taps:	1113	275
T/Layer:	104	95
Layers:	22	6
Lead Wire Colors:	S — 1 Black T — 2 Red F — 3 Blue	S — 4 Yellow T — GND F — 5 Green
Tube Size:	5/8" x 5/8"	
Layer Ins.:	0.001 Glassine	0.0015 Glassine
Wrapper:	2 layers 0.005 Kraft	2 layers 0.005 Gummed Kraft
Core Stack and Thickness:	5/8 — 0.014"	
Test Volts:	1500 V RMS	1500 V RMS
DCR:	200 ohms ± 15 o/o	47 ohms ± 15 o/o
Test:	L ₄₋₅ = 2.5 hys. min. at 10V — 60 cps.	

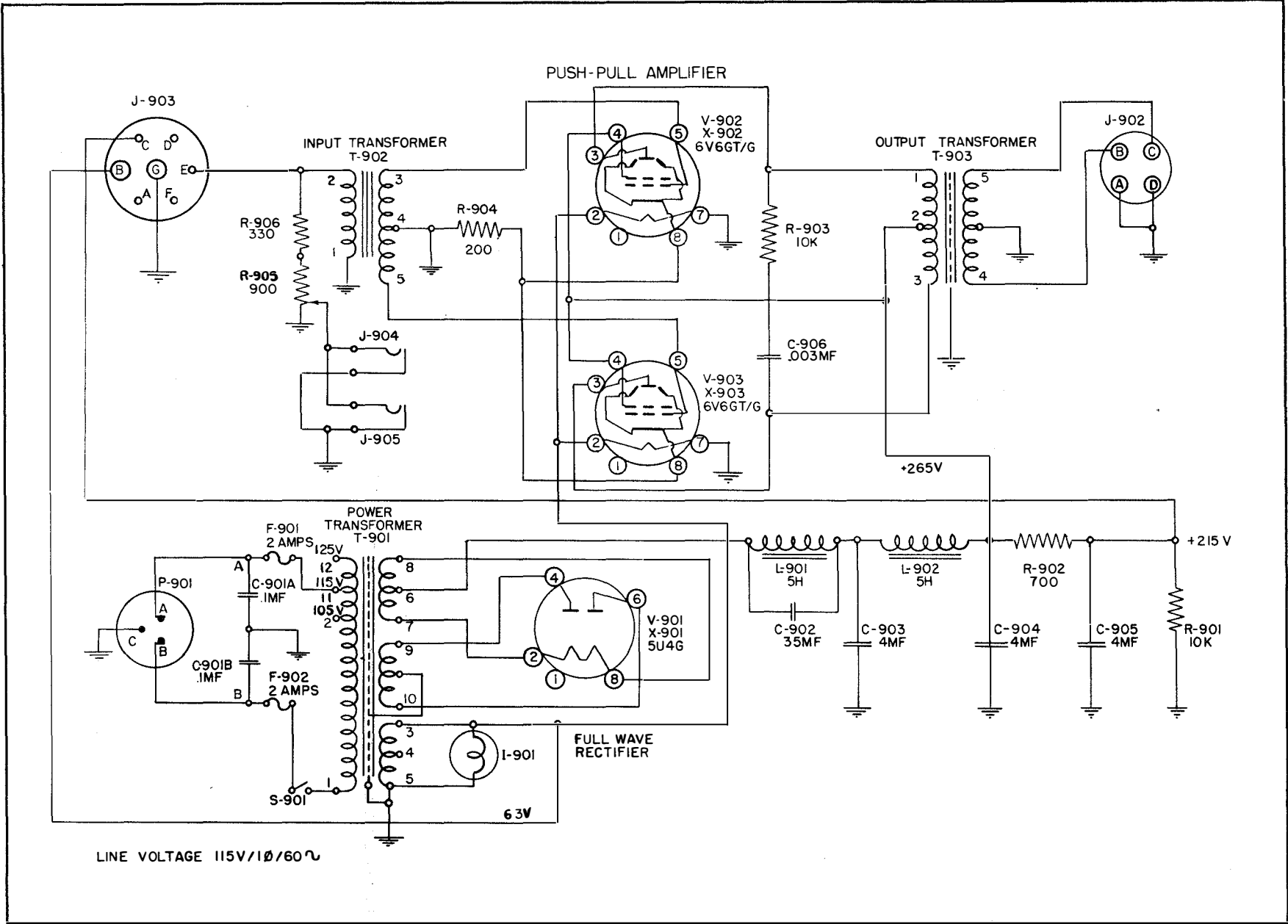

Figure 7-18. Complete Schematic Diagram of Rectifier Power Supply Unit Navy Type PP-445/FRR



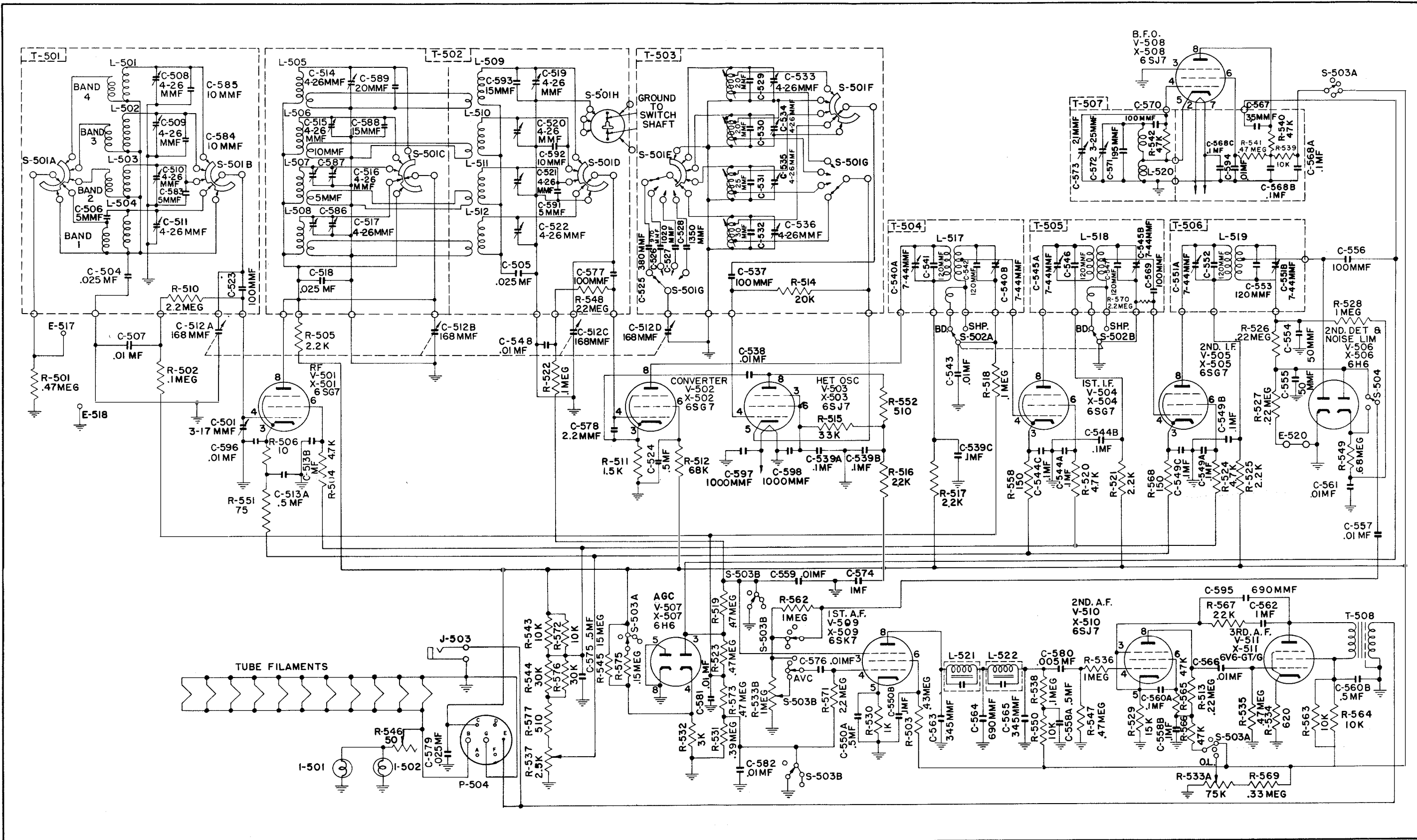

Figure 7-19. Complete Schematic Diagram of Radio Receiver Navy Type R-303/FRR

ORIGINAL

7-31, 7-32

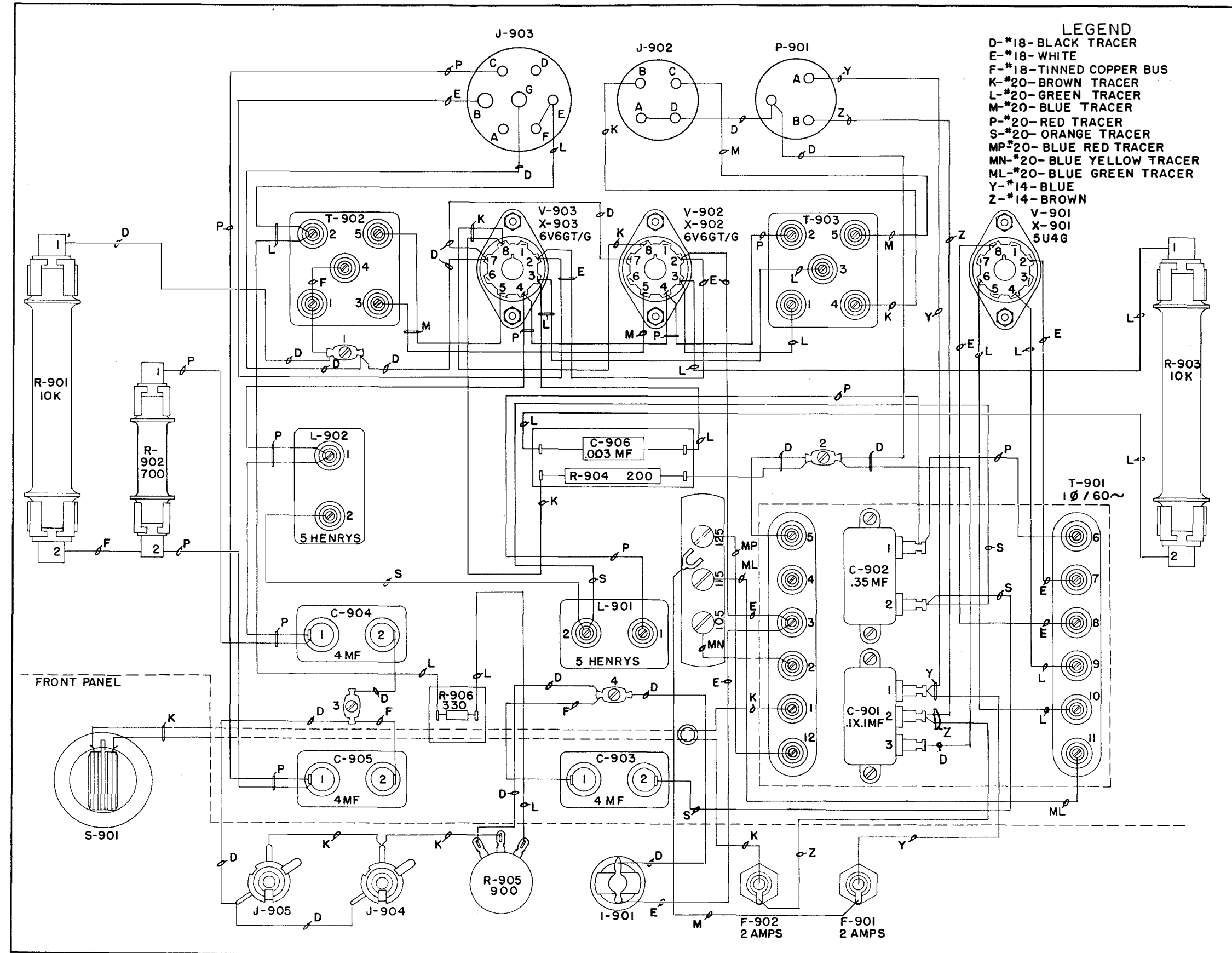

Figure 7-20. Rectifier Power Amplifier, Wiring Diagram

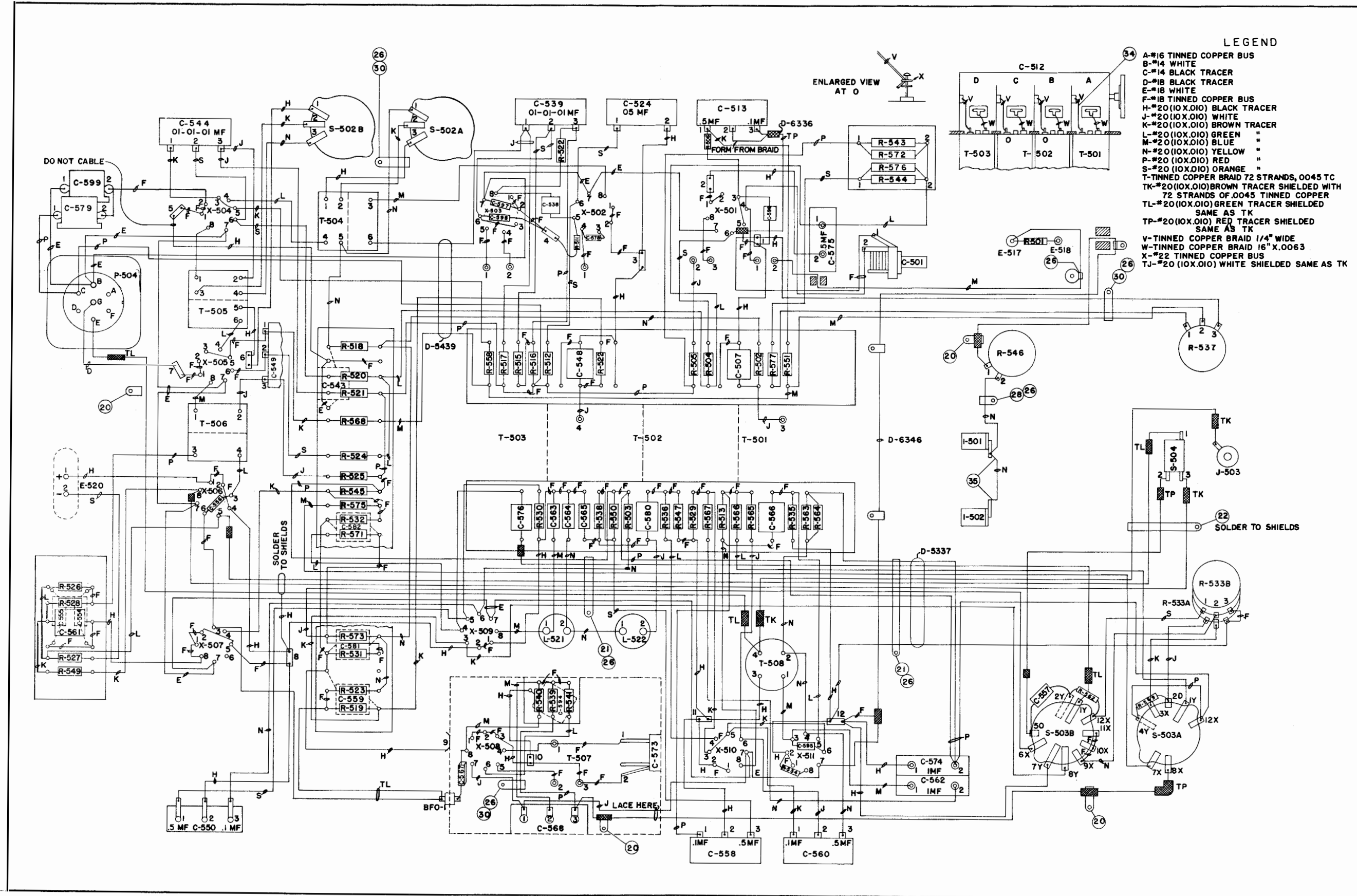
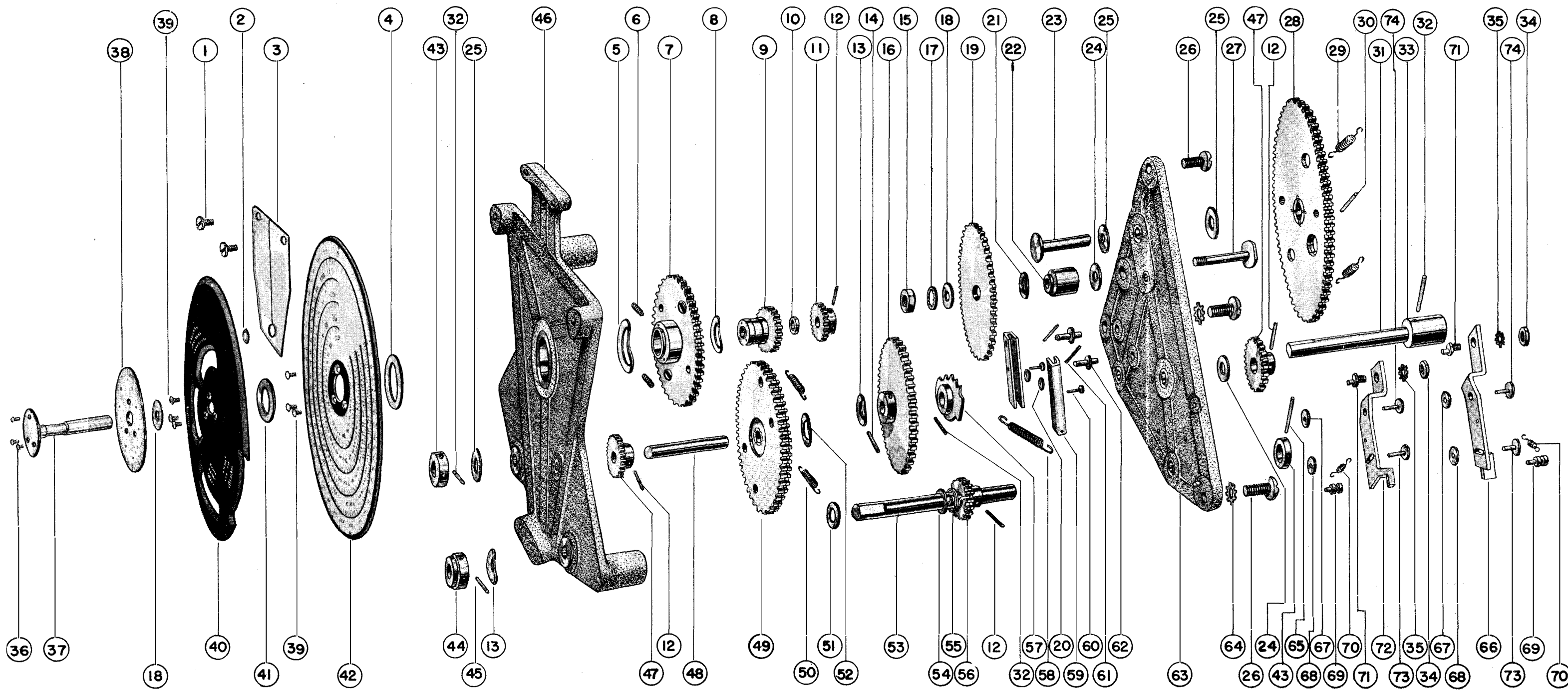

Figure 7-21. Radio Receiver, Wiring Diagram

ORIGINAL

7-35, 7-36



ITEM	CONTRACTOR'S DWG. OR PART NO.	DESCRIPTION
55	100109	St. Steel Spring Wire
56	100110, 100111	Dial Drive Gear
57	100102	Detent
58	100141	Detent Spring
59	100038	Arm

ITEM	CONTRACTOR'S DWG. OR PART NO.	DESCRIPTION
60	120022-1	Rivet
61	100951	St. Steel Wire
62	100097	Stud
63	300786-A-2	Rear Plate
64	D16CX	Shakeproof Lockwasher

ITEM	CONTRACTOR'S DWG. OR PART NO.	DESCRIPTION
65	3-110155-3	Taper Pin
66	100095	Stop Arm
67	120146-1	Washer
68	120146-2	Washer
69	100099	Post

ITEM	CONTRACTOR'S DWG. OR PART NO.	DESCRIPTION
70	100142	Spring
71	100100	Eccentric
72	100094	Stop Arm
73	100098	Guide Pin
74	100101	Fulcrum Pin

Figure 7-22. Tuning Dial Assembly U-501 Exploded View

ORIGINAL

ITEM	CONTRACTOR'S DWG. OR PART NO.	DESCRIPTION
1	11CKBF8	BHBM Screw
2	100143	Felt Pad
3	100096	Indicator
4	1-120145-1	Washer
5	120147-1	Spring Washer
6	100128	Gear Spring
7	200163-A	Dial Gear
8	120147-2	Spring Washer
9	100125	Masking Plate Gear
10	100138	Washer
11	100139	Vernier Gear
12	2-110155-1	Taper Pin
13	120147-3	Spring Washer
14	2-110155-2	Taper Pin
15	H19CBF	Tex Brass Nut
16	100144	Masking Plate Driver Gear
17	C19CX	Shakeproof Lockwasher
18	1-120145-4	Washer
19	100118	Masking Plate Idler Gear
20	100021	Washer
21	120147-4	Washer
22	100119	Spacer
23	100023	Shaft
24	1-120145-4	Washer
25	1-120145-9	Washer
26	16CKBF16	BHBM Screw
27	100024	Stud
28	200131-A	Condenser Drive Gear
29	100132	Spring
30	2-110155-3	Taper Pin
31	100133	Detent Shaft
32	3-110155-2	Taper Pin
33	100140	Collar
34	H14CBF	6-40 x 1/4" Nut
35	D14CX	Shakeproof Lockwasher
36	1-110148-1	Rivet
37	100115	Shaft
38	120107	Vernier Dial
39	09CACX8	FH St. Steel Screw
40	100116	Masking Plate
41	1-120145-5	Washer
42	220151	Dial
43	100112	Collar
44	100114	Dial Lock Hub
45	3-110155-2	Taper Pin
46	300786-A-1	Front Plate
47	100159	Dial Pinion Gear
48	100130	Vernier Idler Shaft
49	200152-A	Vernier Idler Gear
50	100132	Idler Gear Spring
51	1-120145-9	Washer
52	120147-5	Spring Washer
53	100113	Dial Drive Shaft
54	110952	"C" Washer

SECTION 8
PARTS LIST

TABLE 8—1. WEIGHTS AND DIMENSIONS OF SPARE PARTS BOXES

EQUIPMENT SPARES					
SPARE PARTS BOX	OVERALL DIMENSIONS				
	HEIGHT	WIDTH	DEPTH	VOLUME	WEIGHT
RBS-3	9 $\frac{1}{4}$	19 $\frac{1}{4}$	13	1.34	56

TABLE 8—2. SHIPPING WEIGHTS AND DIMENSIONS OF SPARE PARTS BOXES

EQUIPMENT SPARES						
SHIPPING BOX NUMBER	SPARE PARTS BOX	OVERALL DIMENSIONS				
		HEIGHT	WIDTH	DEPTH	VOLUME	WEIGHT
2	RBS-3	11 $\frac{3}{8}$	23 $\frac{3}{4}$	14 $\frac{7}{8}$	2.27	75

TABLE 8—3. LIST OF MAJOR UNITS

SYMBOL GROUP	QUANTITY 115/1/60	NAME OF MAJOR UNIT	NAVY TYPE
101-199	1	Interconnecting Cable Assy.	
501-599	1	Radio Receiver	R-303/FRR
901-999	1	Power Supply	PP-445/FRR

TABLE 8-4. COMBINED PARTS & SPARE PARTS LIST

SYM- BOL DESIG.	NAME OF PART AND DESCRIPTION	FUNCTION	JAN AND NAVY TYPE NO.	STOCK NO. STANDARD NAVY	MFG. & MFGRS. DESIG- NATION	CON- TRACTOR DWG. & PART NO.	ALL SYMBOLS DESIGNATION INVOLVED	TOTAL ON PER EQUIP.	SPARE PARTS						
									ITEM NO.	EQUIP		TEN- DER		STOCK	
										QUAN. BOX	QUAN. BOX	QUAN. BOX	QUAN. BOX		
A-501	Cabinet, receiver:	Drip proof cover		Shop Manufacture	The Sealtron Co.	500030	A-501	1	0						
A-502	Cover assembly: dial	Dial cover		Shop Manufacture	The Sealtron Co.	200311-A	A-502	1	0						
A-503	Cover assembly: calibration card	Calibration card cover and retainer		Shop Manufacture	The Sealtron Co.	200418-A	A-503	1	0						
A-504	Mount: vibration	Receiver cabinet shock mounting		N17-M-75034-3431	Lord No. 102P10	120268-1	A-504	4	0						
A-505	Mounting Plate	Receiver mounting		Shop Manufacture	The Sealtron Co.	300422-A	A-505	1	0						
A-901	Cover: phone jack	For J-904 & J-905		*	Croname No. 23559-2	110370	A-901	2	0						
A-902	Cap Assembly	Access for adjustment of R-905		*	The Sealtron Co.	100351-A	A-902	1	0						
A-903	Cover: dust; captivated	Cover for P-902		*	Amphenol 9760-18(6-4M)	100726	A-903	1	0						
A-904	Mount, vibration	Power amplifier shock mounting		N17-M-75051-3501	Lord No. 102P12	110262-1	A-904	6	0						
A-905	Cabinet, power supply	Drip proof cover		Shop Manufacture	The Sealtron Co.	500165	A-905	1	0						
A-906	Mounting plate	Power amplifier mtg.		Shop Manufacture	The Sealtron Co.	300211	A-906	1	0						
C-501	Capacitor, variable: air dielectric, plate meshing type: single section; 3-17 mmf SLC; 600 VDCW	Antenna compensator		N16-C-57601-8939	F. W. Sickles Co No. ARL-23	220483	C-501	1	0						
C-504	Capacitor, fixed: mica dielectric .025 MF ±10%, 600 VDCW	Tracking, antenna stage	48591B10	For Replacement use N16-C-34514-5977	Aerovox Corp. No. 1445 LS	3-110443-1	C-504, C-505 C-518, C-579	4	0						
C-505	Capacitor, same as C-504	Tracking converter- grid.													
C-506	Capacitor, fixed: mica dielectric: 5mmf ±10%, 500 VDCW	Antenna coupling Band 1	48771B10	For Replacement use N16-C-25107-8756	Aerovox Corp. No. 1468 LS	110570-23	C-506	1	0						
C-507	Capacitor, fixed: mica dielectric: .01 mf ±10%, 300 VDCW	Bypass, RF AVC	CM35B103K	For Replacement use N16-C-3362-5588	Aerovox Corp. No. 1467 LSX	110570-2	C-507, C-538 C-543, C-548 C-557, C-559 C-561, C-576 C-581, C-582 C-594, C-596 C-566	13	0						

*If required will be procured by nearest Naval Shore Supply Activity on demand.

ORIGINAL

TABLE 8-4. COMBINED PARTS AND SPARE PARTS LIST — CONTINUED

ORIGINAL

SYM- BOL DESIG.	NAME OF PART AND DESCRIPTION	FUNCTION	JAN AND NAVY TYPE NO.	STOCK NO. STANDARD NAVY	MFGR. & MFGRS. DESIG- NATION	CON- TRACTOR DWG. & PART NO.	ALL SYMBOLS DESIGNATION INVOLVED	TOTAL ON PER EQUIP.	SPARE PARTS						
									ITEM NO.	EQUIP		TEN- DER		STOCK	
										QUAN.	BOX	QUAN.	BOX	QUAN.	BOX
C-508	Capacitor, variable air dielectric; plate meshing type single section 4-26 mmf; SLC 600 VDCW	Trimmer RF grid Band 4		For Replacement use N16-C-58941-1500	F. W. Sickles Co. No. ARL 21 Spl.	120438	C-508, C-509 C-510, C-511 C-514, C-515 C-516, C-517 C-519, C-520 C-521, C-522 C-533, C-534 C-535, C-536	16	0						
C-509	Capacitor, same as C-508	Trimmer RF grid Band 3													
C-510	Capacitor, same as C-508	Trimmer RF grid Band 2													
C-511	Capacitor, same as C-508	Trimmer RF grid Band 1													
C-512	Capacitor, variable air dielectric; plate meshing type four section 12.5-168 mmf each section 600 VDCW		482509	N16-C-60952-2201	Radio Condenser Co. CN-886831	320081	C-512	1	0						
C-512A	Capacitor, part of C-512	Main tuning RF grid		For Reference Only											
C-512B	Capacitor, part of C-512	Main tuning RF plate		For Reference Only											
C-512C	Capacitor, part of C-512	Main tuning converter		For Reference Only											
C-512D	Capacitor, part of C-512	Main tuning heterodyne oscillator		For Reference Only											
C-513	Capacitor, fixed; paper dielectric; 2 section: .5 mfd-common- .1mf ±10% - 3%; 400 VDCW		481464	N16-C-53106-8805	Aerovox Corp. No. 430	120466	C-513, C-550 C-558	3	0						
C-513A	Capacitor, part of C-513 .5 mfd; ±10% - 3%; 400 VDCW	Bypass RF cathode		For Reference Only			C-513A, C-550A C-558A								
C-513B	Capacitor, part of C-513 ±10% - 3%; 400 VDCW	Bypass RF screen		For Reference Only			C-513B, C-550B C-558B								
C-514	Capacitor, same as C-508	Trimmer, RF plate Band 4													
C-515	Capacitor, same as C-508	Trimmer, RF plate Band 3													

PARTS LIST

NAVSHIPS 91944

RBS-3

Section 8
C-508—C-515

8-3

TABLE 8-4. COMBINED PARTS & SPARE PARTS LIST — CONTINUED

SYM- BOL DESIG.	NAME OF PART AND DESCRIPTION	FUNCTION	PARTS					SPARE PARTS									
			JAN AND NAVY TYPE NO.	STOCK NO. STANDARD NAVY	MFGR. & MFGRS. DESIG- NATION	CON- TRACTOR DWG. & PART NO.	ALL SYMBOLS DESIGNATION INVOLVED	TOTAL ON PER EQUIP.	ITEM NO.	EQUIP		TEN- DER		STOCK			
										QUAN.	BOX	QUAN.	BOX	QUAN.	BOX		
C-516	Capacitor, same as C-508	Trimmer, RF plate Band 2															
C-517	Capacitor, same as C-508	Trimmer, RF plate Band 1															
C-518	Capacitor, same as C-504	Filter, RF plate															
C-519	Capacitor, same as C-508	Trimmer, converter grid, Band 4															
C-520	Capacitor, same as C-508	Trimmer, converter grid, Band 3															
C-521	Capacitor, same as C-508	Trimmer, converter grid, Band 2															
C-522	Capacitor, same as C-508	Trimmer, converter grid, Band 1															
C-523	Capacitor, fixed mica dielectric; 100 mmf $\pm 10\%$; 500 VDCW	Coupling RF grid	CM20B101K 48674B10	N16-C-28558-1676	Aerovox Corp. No. 146B LS	110570-3	C-523, C-556 C-569, C-570 C-577, C-537	6		0							
C-524	Capacitor, fixed: paper dielectric; .5 mf $\pm 10\%$; 600 VDCW	Bypass converter screen	481223	N16-C-47297-2870	Aerovox Corp. No. 630	120468	C-524	1		0							
C-525	Capacitor, fixed: silvered mica dielectric; 380 mmf $\pm 2\%$; 500 VDCW	Series tracking osc. Band 1	481492-D2	For Replacement use N16-C-29866-2126	Aerovox Corp. No. 1469 T	110570-4	C-525	1		0							
C-526	Capacitor, fixed: silvered mica dielectric; 970 mmf $\pm 2\%$ 500 VDCW	Series tracking osc. Band 2		N-16-C-30447-1527	Aerovox Corp. No. 1469 T	120542-10	C-526	1		0							
C-527	Capacitor, fixed: silvered mica dielectric; 1020 mmf $\pm 2\%$; 500 VDCW	Series tracking osc. Band 3		N16-C-31105-7677	Aerovox Corp. No. 1464 T	110570-6	C-527	1		0							
C-528	Capacitor, fixed: silvered mica dielectric; 1350 mmf $\pm 2\%$; 500 VDCW	Series tracking osc. Band 4	481495-D2	N16-C-31396-7014	Aerovox Corp. No. 1464 T	110570-7	C-528	1		0							
C-529	Capacitor, fixed: ceramic dielectric 20 mmf $\pm 5\%$ negative temp coef	Compensator osc. Band 4	CC20SH200J	N16-C-16083-5836	Hi-Q Div. Aerovox Corp. Type CN-1	120446-4	C-529, C-530	2		0							
C-530	Capacitor, same as C-529	Compensator osc. Band 3															
C-531	Capacitor, fixed: ceramic 24 mfd $\pm 2\%$ negative temp coef	Compensator osc. Band 2	CC20RH240G	N16-C-16211-6101	Hi-Q Div. Aerovox Corp. Type CN-1	120446-1	C-531	1		0							

ORIGINAL

ORIGINAL

TABLE 8-4. COMBINED PARTS & SPARE PARTS LIST — CONTINUED

SYM- BOL DESIG.	NAME OF PART AND DESCRIPTION	FUNCTION	PARTS					SPARE PARTS							
			JAN AND NAVY TYPE NO.	STOCK NO. STANDARD NAVY	MFGR. & MFGRS. DESIG- NATION	CON- TRACTOR DWG. & PART NO.	ALL SYMBOLS DESIGNATION INVOLVED	TOTAL ON PER EQUIP.	ITEM NO.	EQUIP		TEN- DER		STOCK	
										QUAN.	BOX	QUAN.	BOX	QUAN.	BOX
C532	Capacitor, fixed ceramic dielectric; 30 mmf $\pm 5\%$, negative temp coef	Compensator osc. Band 1	CC20PH300J		Hi-Q Div. Aerovox Corp. Type CN-1	120446-5	C-532	1		0					
C-533	Capacitor, same as C-508	Trimmer osc. Band 4													
C-534	Capacitor, same as C-508	Trimmer osc. Band 3													
C-535	Capacitor, same as C-508	Trimmer osc. Band 2													
C-536	Capacitor, same as C-508	Trimmer osc. Band 1													
C-537	Capacitor, same as C-523	Coupling osc. to grid.													
C-538	Capacitor, same as C-507	Coupling osc. to converter													
C-539	Capacitor, fixed: paper dielectric; 3 section .1 mf per section $\pm 10\%$ 3% 600 VDCW		481466	For Replacement use N16-C-54432-8720	Aerovox Corp. No. 630	120469	C-539, C-544 C-549, C-568	4		0					
C-539A	Capacitor, part of C-539; .1 mf $\pm 10\%$ - 3%; 600 VDCW	Bypass osc. screen		For Reference Only			C-539A, C-544A C-549A, C-568A								
C-539B	Capacitor, part of C-539; .1 mf $\pm 10\%$ - 3%; 600 VDCW	Filter osc. plate		For Reference Only			C-539B, C-544B C-549B, C-568B								
C-539C	Capacitor, part of C-539; .1 mf $\pm 10\%$ - 3%; 600 VDCW	Filter converter plate		For Reference Only			C-539C, C-544C C-549C, C-568C								
C-540	Capacitor, variable: air dielectric; 2 section 7-44 mmf each; 500 VDCW		482501	N16-C-62388-2962	F. W. Sickles Co ATF14F Sp	220565	C-540, C-545 C-551	3		0					
C-540A	Capacitor, part of C-540; 7-44 mmf; 500 VDCW	Trimmer variable 1st IF primary		For Reference Only			C-540A, C-545A C-551A								
C-540B	Capacitor, part of C-540; 7-44 mmf; 500 VDCW	Trimmer variable 1st IF secondary		For Reference Only			C-545B, C-551B C-540B								
C-541	Capacitor, fixed: silvered mica dielectric; 120 mmf $\pm 2\%$; 500 VDCW	Trimmer, fixed 1st IF primary	CM20C121G 481496-C3	N16-C-28732-5521	Aerovox Corp. No. 1469 T	110570-11	C-541, C-542 C-546, C-547 C-552, C-553	6		0					
C-542	Capacitor, same as C-541	Trimmer, fixed 1st IF secondary													
C-543	Capacitor, same as C-507	Bypass 1st IF AGC													

PARTS LIST

NAVSHIPS 91944
RBS-3Section 8
C-532—C-543

8-5

TABLE 8-4. COMBINED PARTS & SPARE PARTS LIST — CONTINUED

PARTS								SPARE PARTS							
SYM- BOL DESIG.	NAME OF PART AND DESCRIPTION	FUNCTION	JAN AND NAVY TYPE NO.	STOCK NO. STANDARD NAVY	MFGR. & MFGRS. DESIG- NATION	CON- TRACTOR DWG. & PART NO.	ALL SYMBOLS DESIGNATION INVOLVED	TOTAL ON PER EQUIP.	ITEM NO.	EQUIP		TEN- DER		STOCK	
										QUAN. BOX	QUAN. BOX	QUAN. BOX	QUAN. BOX		
C-544	Capacitor, same as C-539														
C-544A	Capacitor, same as C-539A	Bypass 1st IF screen													
C-544B	Capacitor, same as C-539B	Filter 1st IF plate													
C-544C	Capacitor, same as C-539C	Bypass 1st IF cathode													
C-545	Capacitor, same as C-540														
C-545A	Capacitor, same as C-540A	Trimmer variable 2nd IF primary													
C-545B	Capacitor, same as C-540B	Trimmer variable 2nd IF secondary													
C-546	Capacitor, same as C-541	Trimmer, fixed 2nd IF primary													
C-547	Capacitor, same as C-541	Trimmer, fixed 2nd IF secondary													
C-548	Capacitor, same as C-507	Bypass, converter AGC													
C-549	Capacitor, same as C-539														
C-549A	Capacitor, same as C-539A	Bypass, 2nd IF screen													
C-549B	Capacitor, same as C-539B	Filter, 2nd IF plate													
C-549C	Capacitor, same as C-539C	Bypass, 2nd IF cathode													
C-550	Capacitor, same as C-513														
C-550A	Capacitor, same as C-513A	Bypass, 1st AF cathode													
C-550B	Capacitor, same as C-513B	Bypass, 1st AF screen													
C-551	Capacitor, same as C-540														
C-551A	Capacitor, same as C-540A	Trimmer, variable 3rd IF primary													
C-551B	Capacitor, same as C-540B	Trimmer, variable 3rd IF secondary													
C-552	Capacitor, same as C-541	Trimmer, fixed 3rd IF primary													
C-553	Capacitor, same as C-541	Trimmer, fixed 3rd IF secondary													

ORIGINAL

TABLE 8-4. COMBINED PARTS & SPARE PARTS LIST — CONTINUED

SYM- BOL DESIG.	NAME OF PART AND DESCRIPTION	FUNCTION	PARTS					SPARE PARTS							
			JAN AND NAVY TYPE NO.	STOCK NO. STANDARD NAVY	MFR. & MFRS. DESIG- NATION	CON- TRACTOR DWG. & PART NO.	ALL SYMBOLS DESIGNATION INVOLVED	TOTAL ON PER EQUIP.	ITEM NO.	EQUIP		TEN- DER		STOCK	
										QUAN.	BOX	QUAN.	BOX	QUAN.	BOX
C-554	Capacitor, fixed mica dielectric; 50 mmf $\pm 10\%$ 500 VDCW	Filter, signal diode	48895-B10	For Replacement use N16-C-27656-2601	Aerovox Corp. No. 1468 LS	110570-12	C-554, C-555	2		0					
C-555	Capacitor, same as C-554	Filter, signal diode													
C-556	Capacitor, same as C-523	Coupling, AGC diode													
C-557	Capacitor, same as C-507	Coupling, volume control													
C-558	Capacitor, same as C-513														
C-558A	Capacitor, same as C-513A	Filter, 1st AF plate													
C-558B	Capacitor, same as C-513B	Filter, 2nd AF plate and screen													
C-559	Capacitor, same as C-507	Filter AGC													
C-560	Capacitor, fixed; paper dielectric 2 section .5 - .1 mf $\pm 10\%$ - 3%, 400 VDCW		481482	N16-C-53106-8815	Aerovox Corp. No. 430	120471	C-560	1		0					
C-560A	Capacitor, part of C-560; .5 mf $\pm 10\%$ - 3%, 400 VDCW	Bypass 2nd AF screen													
C-560B	Capacitor, part of C-560; .5 mf $\pm 10\%$ - 3%, 400 VDCW	Filter 3rd AF plate and screen													
C-561	Capacitor, same as C-507	Bypass peak limiter load													
C-562	Capacitor, fixed; paper dielectric .1 mf $\pm 10\%$ 3%, 400 VDCW	Feedback coupling	481469	N16-C-48792-9198	Aerovox Corp. No. 418B	120488	C-562, C-574	2		0					
C-563	Capacitor, fixed; mica dielectric, 345 mmf $\pm 5\%$; 500 VDCW	Filter, low pass	481490-B5	For Replacement use N16-C-29819-2406	Aerovox Corp. No. 1468 LS	110570-13	C-563, C-565	2		0					
C-564	Capacitor, fixed; mica dielectric; 690 mmf $\pm 5\%$; 500 VDCW	Filter, low pass	481491-B5	For Replacement use N16-C-30531-4294	Aerovox Corp. No. 1468 LS	110570-14	C-564, C-595	2		0					
C-565	Capacitor, same as C-563	Filter, low pass													
C-566	Capacitor, same as C-507	Coupling, 3rd AF grid													

TABLE 8-4. COMBINED PARTS & SPARE PARTS LIST — CONTINUED

SYM- BOL DESIG.	NAME OF PART AND DESCRIPTION	FUNCTION	JAN AND NAVY TYPE NO.	STOCK NO. STANDARD NAVY	MFG. & MFGS. DESIG- NATION	COM- TRACTOR DWG. & PART NO.	ALL SYMBOLS DESIGNATION INVOLVED	TOTAL ON PER EQUIP.	SPARE PARTS						
									ITEM NO.	EQUIP.		TENDER		STOCK	
										QUAN.	BOX	QUAN.	BOX	QUAN.	BOX
C-567	Capacitor, fixed; mica dielectric; 3.5 mmf $\pm 14\%$; 500 VDCW	Coupling CW osc.	481497-B14	N16-C-24737-7903	Aerovox Corp. No. 1468 LS	110570-15	C-567	1	0						
C-568A	Capacitor, same as C-539A	Bypass CW osc. +B													
C-568B	Capacitor, same as C-539B	Filter CW osc.													
C-568C	Capacitor, same as C-539C	Bypass CW osc. heater													
C-569	Capacitor, same as C-523	Coupling, 2nd IF grid													
C-570	Capacitor, same as C-523	Coupling CW osc. grid													
C-571	Capacitor, fixed; silvered mica dielectric 195 mmf $\pm 3\%$; 500 VDCW	Trimmer fixed CW oscillator	481498-D3	N16-C-29238-1123	Aerovox Corp. No. 1469 T	110570-16	C-571	1	0						
C-572	Capacitor, variable; air dielectric; plate meshing type; single section 4-26 mmf; SLC 600 VDCW	Trimmer, variable CW oscillator	482502	For Replacement use N16-C-59025-5721	F. W. Sickles Co. ARL-21-N SP	220779	C-572	1	0						
C-573	Capacitor, variable; air dielectric; plate meshing type single section 2.1 mmf $\pm .2$ mmf; SLC; 600 VDCW	Vernier CW osc.	482505	N16-C-57980-1549	F. W. Sickles ARL-O Spcl	220481	C-573	1	0						
C-574	Capacitor, same as C-562	Bypass high voltage													
C-575	Capacitor, fixed; paper dielectric; .5 mf +10% — 3%; 400 VDCW	Filter, screen supply	481470A	N16-C-47272-9445	Aerovox Corp. No. 430	120486	C-575	1	0						
C-576	Capacitor, same as C-507	Coupling, 1st AF grid													
C-577	Capacitor, same as C-523	Coupling, converter grid													
C-578	Capacitor, fixed; ceramic dielectric, 2.0 mmf $\pm .25$ mmf; negative temp. coef.; 500 VDCW	Fixed trimmer converter grid	CC20HK020C		Hi-Q Div. Aerovox Corp. Type CN-1	120446-3	C-578	1	0						
C-579	Capacitor, same as C-504	Bypass +B													

ORIGINAL

TABLE 8-4. COMBINED PARTS & SPARE PARTS LIST — CONTINUED

SYM- BOL DESIG.	NAME OF PART AND DESCRIPTION	FUNCTION	JAN AND NAVY TYPE NO.	STOCK NO. STANDARD NAVY	MFR. & MFRS. DESIG- NATION	CON- TRACTOR DWG. & PART NO.	ALL SYMBOLS DESIGNATION INVOLVED	PARTS							
								TOTAL ON PER EQUIP.	ITEM NO.	EQUIP		TEN- DER		STOCK	
										QUAN.	BOX	QUAN.	BOX	QUAN.	BOX
C-580	Capacitor, fixed; mica dielectric .005 mfd $\pm 10\%$; 500 VDCW	Coupling, 2nd AF grid	481037-B10	For Replacement use N16-C-32720-7670	Aerovox Corp. No. 1467 LS	110570-18	C-580	1		0					
C-581	Capacitor, same as C-507	Filter, RF and IF AGC													
C-582	Capacitor, same as C-507	Filter, 1st AF AGC													
C-583	Capacitor, fixed; silvered mica dielectric; 5 mmf $\pm 20\%$; 500 VDCW	Fixed, trimmer ant. Band 2	CM20B050M 48771-B20	N16-C-25107-8756	Aerovox Corp. No. 1468 LS	110570-19	C-583, C-586 C-591	3		0					
C-584	Capacitor, fixed; silvered mica dielectric 10 mmf $\pm 10\%$; 500 VDCW	Fixed, trimmer ant. Band 3	487710-D10	N16-C-26025-8281	Aerovox Corp. No. 1469T	110570-20	C-584, C-585 C-587, C-592	4		0					
C-585	Capacitor, same as C-584	Fixed, trimmer ant. Band 4													
C-586	Capacitor, same as C-583	Fixed, trimmer RF plate Band 1													
C-587	Capacitor, same as C-584	Fixed, trimmer RF plate Band 2													
C-588	Capacitor, fixed; silvered mica dielectric 15 mmf $\pm .1$ mmf; 500 VDCW	Fixed, trimmer RF plate Band 3	48840-B7	For Replacement use N16-C-26442-8196	Aerovox Corp. No. 1468 LS	110727-1	C-588, C-593	2		0					
C-589	Capacitor, fixed; silvered mica dielectric; 20 mmf $\pm 5\%$; 500 VDCW	Fixed, trimmer RF plate Band 4	CM20B200J 48783-C5	N16-C-26732-9601	Aerovox Corp. No. 1469	110570-21	C-589	1		0					
C-590	Not used														
C-591	Capacitor, same as C-583	Fixed, trimmer converter grid Band 2													
C-592	Capacitor, same as C-584	Fixed, trimmer converter grid Band 3													
C-593	Capacitor, same as C-588	Fixed, trimmer converter grid Band 4													
C-594	Capacitor, same as C-507	Bypass CW osc. screen													
C-595	Capacitor, same as C-564	Compensator, feed back													
C-596	Capacitor, same as C-507	Bypass RF cathode													

TABLE 8-4. COMBINED PARTS & SPARE PARTS LIST — CONTINUED

SYM- BOL DESIG.	NAME OF PART AND DESCRIPTION	FUNCTION	JAN AND NAVY TYPE NO.	STOCK NO. STANDARD NAVY	MFGR. & MFGRS. DESIG- NATION	CON- TRACTOR DWG. & PART NO.	ALL SYMBOLS DESIGNATION INVOLVED	SPARE PARTS							
								TOTAL ON PER EQUIP.	ITEM NO.	EQUIP		TEN- DER		STOCK	
										QUAN.	BOX	QUAN.	BOX	QUAN.	BOX
C-597	Capacitor, fixed; mica dielectric; 1000 mmf $\pm 10\%$; 300 VDCW	Bypass osc. heater	CM25B102K 481070-B10	For Replacement use N16-C-31090-4164	Aerovox Corp. No. 1468 LS	110570-22	C-597, C-598	2		0					
C-598	Capacitor, same as C-597	Bypass osc. screen													
C-599	Capacitor, fixed; mica dielectric; 10,000 mmf, 10%; 1200 VDCW	Bypass, tube heaters at P-504	CM50B103K	For Replacement use N16-C-33618-2690	Aerovox Corp. No. 1445 LS	4-110443-2	C-599	1		0					
C-901	Capacitor, fixed; paper dielectric; 2 section; .1 mf $\pm 10\%$; 600 VDCW		481465-B10	N16-C-53148-7754	Aerovox Corp. No. 430	120368	C-901	1		0					
C-901A	Capacitor, part of C-901	Filter, line		For Reference Only											
C-901B	Capacitor, part of C-901	Filter, line		For Reference Only											
C-902	Capacitor, fixed; paper dielectric; .35 mf $\pm 10\%$ - 3%; 400 VDCW	(120 cycles) Reactor, tuning	481483	N16-C-46702-9445	Aerovox Corp. No. 430	120367	C-902	1		0					
C-903	Capacitor, fixed; paper dielectric; 4 mf $\pm 10\%$, 600 VDCW	Filter, +B (first)		N16-C-49957-5925	Aerovox Corp. No. 609 R	120349	C-903, C-904 C-905	3		0					
C-904	Capacitor, same as C-903	Filter, +B (second)													
C-905	Capacitor, same as C-903	Filter, +B (third)													
C-906	Capacitor, fixed; mica dielectric; .003 mf $\pm 5\%$; 500 VDCW	AF limiting	CM30B302J	For Replacement use N16-C-32194-2494	Aerovox Corp. No. 1467	110570-24	C-906	1		0					
E-501	Board, terminal; 30 terms	Mounting for misc. capacitors and resistors		Shop Manufacture	The Sealtron Co.	200285-A	E5-01	1		0					
E-502	Board, terminal; 38 terms	Mounting for misc. capacitors and resistors		Shop Manufacture	The Sealtron Co.	200284-A	E-502	1		0					
E-503	Board, terminal; 32 terms	Mounting for misc. capacitors and resistors		Shop Manufacture	The Sealtron Co.	200283-A	E-503	1		0					
E-504	Board, terminal; 7 terms	Mounting for misc. capacitors and resistors		Shop Manufacture	The Sealtron Co.	100282-A	E-504	1		0					

ORIGINAL

TABLE 8-4. COMBINED PARTS & SPARE PARTS LIST — CONTINUED

SYM- BOL DESIG.	NAME OF PART AND DESCRIPTION	FUNCTION	JAN AND NAVY TYPE NO.	STOCK NO. STANDARD NAVY	MFG. & MFGRS. DESIG- NATION	CON- TRACTOR DWG. & PART NO.	ALL SYMBOLS DESIGNATION INVOLVED	TOTAL ON PER EQUIP.	SPARE PARTS						
									ITEM NO.	EQUIP		TEN- DER		STOCK	
										QUAN.	BOX	QUAN.	BOX	QUAN.	BOX
E-505	Board, terminal; 12 terms	Mounting for misc. capacitors and resistors		Shop Manufacture	The Sealtron Co.	100281-A	E-505	1	0						
E-506	Board, terminal; 4 terms	Mounting for misc. resistors		Shop Manufacture	The Sealtron Co.	100280-A	E-506	1	0						
E-507	Knob, round, black bakelite; with level bar	Band switch		*	Molded Insulation Co. RE10F479C Type E; lever	110474	E-507	1	0						
E-508	Knob, round, black bakelite; with crank	Band tuning		*	Molded Insulation Co. RE10F479C Type E; crank	110475	E-508	1	0						
E-509	Knob, round, black bakelite; with pointer 1 1/8 dia	Gain control		*	Molded Insulation Co. RE10F494C, Type A	110426-1	E-509, E-510 E-511, E-512	4	0						
E-510	Knob, same as E-509	Output level control													
E-511	Knob, same as E-509	Antenna compensator													
E-512	Knob, same as E-509	B.F.O. Vernier control													
E-513	Knob, round; black bakelite; with pointer 1 1/2 dia.	Selectivity switch		*	Molded Insulation Co. RE10F479C Type B	110426-2	E-513, E-514	2	0						
E-514	Knob, same as E-513	Reception switch													
E-515	Knob, round, black bakelite; brass insert	Facilitate removal		*	Harry Davis Moulding Co. No. 3003	110476-1	E-515	2	0						
E-516	Insulator, bushing, glazed steatite	B.F.O. Terminal		*	Stupakof Ceramic Mfg. No. SE79-0350	110411	E-516	4	0						
E-517	Post, binding push type 1" stud; .066 x 3/8" pin; engraved head	Antenna terminal		*	American Radio Hardware Sp. No. 1756	1-110182-2	E-517	1	0						
E-518	Post, binding push type 3/8" stud; .066 x 3/8" pin; engraved head	Ground terminal		*	American Radio Hardware Sp. No. 1756	2-110182-1	E-518	1	0						

*If required will be procured by nearest Naval Shore Supply Activity on demand.

TABLE 8-4. COMBINED PARTS & SPARE PARTS LIST — CONTINUED

SYM- BOL DESIG.	NAME OF PART AND DESCRIPTION	FUNCTION	PARTS					SPARE PARTS							
			JAN AND NAVY TYPE NO.	STOCK NO. STANDARD NAVY	MFGR. & MFGRS. DESIG- NATION	CON- TRACTOR DWG. & PART NO.	ALL SYMBOLS DESIGNATION INVOLVED	TOTAL ON PER EQUIP.	ITEM NO.	EQUIP		TEN- DER		STOCK	
										QUAN.	BOX	QUAN.	BOX	QUAN.	BOX
E-519	Knob, round, seriated, 1/2" dia. x 1 1/8" long, with dot pointer	Dial lamp dimmer control		Shop Manufacture	Z&W Mach. Prod. Inc.	100575	E-519	1		0					
E-520	Board, terminal; 2 brass nickel plated screw terminal on a moulded phenolic board	2nd detector diode current terminals		N17-B-77536-1105	H. B. Jones No. 2-76	110484	E-520	1		0					
E-521	Adapter, male contact; coaxial cylindrical contact	Intermediate antenna connector		Shop Manufacture	National Elec. Machine Shop CN-49120	200299-A	E-521	1		0					
E-522	Adapter, female contact; coaxial cylindrical con- tact with a binding post adapter	Antenna input adapter to E-521		Shop Manufacture	National Elec. Machine Shop	110260	E-522	1		0					
E-901	Holder, fuse, extractor type; panel mounting for cartridge fuse	AC line		For Replacement use N17-F-74267-6775	Littlefuse No. 341001	110560	E-901, E-902 E-903, E-904	4		0					
E-902	Holder, same as E-901	AC line													
E-903	Holder, same as E-901	Spare fuse holder													
E-904	Holder, same as E-901	Spare fuse holder													
E-905	Board, terminal; 4 terms	Mounting for R-904 and C-906		Shop Manufacture	Z&W Mach. Prod. Inc.	100274-A	E-905	1		0					
E-906	Board, terminal; 2 terms	Mounting for R-906		Shop Manufacture	Z&W Mach. Prod. Inc.	100244-A	E-906	1		0					
E-907	Board, terminal; 3 screw terms	Mounting for power transformer primary taps		Shop Manufacture	The Sealtron Co.	110870	E-907	1		0					
E-908	Board, terminal; 2 clip terms	Mounting for filter resistor, R-902		Shop Manufacture	The Sealtron Co.	200240-A	E-908	1		0					
E-909	Board, terminal; 2 clip terms	Mounting for bleeder resistor, R-901		Shop Manufacture	The Sealtron Co.	200401-A	E-909	1		0					
E-910	Board, terminal; 2 clip terms	Mounting for bleeder resistor, R-903		Shop Manufacture	The Sealtron Co.	200229-A	E-910	1		0					
F-901	Fuse, cartridge; 2 amp. 250 volts; extractor type	AC line		G17-F-16302-100	Littlefuse No. 312002	110576	F-901, F-902	4		0					
F-902	Fuse, same as F-901	AC line													

ORIGINAL

TABLE 8-4. COMBINED PARTS & SPARE PARTS LIST — CONTINUED

SYM- BOL DESIG.	NAME OF PART AND DESCRIPTION	FUNCTION	JAN AND NAVY TYPE NO.	STOCK NO. STANDARD NAVY	MFGR. & MFGRS. DESIG- NATION	CON- TRACTOR DWG. & PART NO.	ALL SYMBOLS DESIGNATION INVOLVED	TOTAL ON PER EQUIP.	SPARE PARTS						
									ITEM NO.	EQUIP		TEN- DER		STOCK	
										QUAN.	BOX	QUAN.	BOX	QUAN.	BOX
H-501	Stud, dial lock	Dial locking plate retainer		Shop Manufacture	Z&W Mach. Prod. Inc.	100162	H-501	1	0						
H-502	Plate, dial locking	Dial locking brake		Shop Manufacture	Z&W Mach. Prod. Inc.	100160	H-502	1	0						
H-503	Tool, tuning	Trimmer tuning		*	American Radio Hardware	110414	H-503	1	0						
H-504	Clamp, cable; waterproof	Cable clamp for interconnecting cable W-101		*	Amphenol 9767- 28-10(6-4M)	110771	H-504, H-903	2	0						
H-505	Wrench, Allen head No. 8	Dial wrench		G41-W-2445	Allen Mfg.	110413-3	H-505	1	0						
H-506	Clamp, tube	Securing V-501 to V-511 inclusive		N16-C-300442-625	Birtcher Corp. No. 926-B-2	110261-3	H-506	11	0						
H-507	Wrench, Allen head No. 6	Dial wrench		G41-W-2446	Allen Mfg.	110413-2	H-507	1	0						
H-901	Clamp, tube	Securing of V-901		N16-C-300798-866	Birtcher Corp. No 926-C	110261-1	H-901	1	0						
H-902	Clamp, tube	Securing of V-902 903		N16-C-300798-621	Birtcher No. 926-B	110261-2	H-902	2	0						
H-903	Clamp, cable; waterproof same as H-504	Cable clamp for W-101 at P-903													
I-501	Clamp, incandescent; 6-8V; .15 amp; bulb T3/4; clear, bayonet base	Receiver, dial lamp		G17-L-6297	General Electric No. 47	110574	I-501, I-502 I-901	3	0						
I-502	Lamp, same as I-501	Receiver, dial lamp													
I-503	Indicator Assembly, vernier dial	Vernier indicator		Shop Manufacture	Z&W Mach. Prod. Inc.	100307-A	I-503	1	0						
I-901	Lamp, same as I-501	Power supply pilot light													
J-501	Connector, female contact; cylindrical brass tubing, phenolic insulated with a coaxial female con- tactor	Antenna input to J-502	49121	For Replacement use N17-C-71120-4869	Electrical Mach. Shops Inc. CN49121	110263	J-501	1	0						
J-502	Connector, female contact, cylindrical brass with a 90° offset phenolic insulated with a coaxial female contactor	Antenna input to E-521 with an offset adapter	49151	N17-C-67446-3796	Electrical Mach. Shops Inc. CN-49151	110264	J-502	1	0						

*If required will be procured by nearest Naval Shore Supply Activity on demand.

TABLE 8-4. COMBINED PARTS & SPARE PARTS LIST — CONTINUED

SYM- BOL DESIG.	NAME OF PART AND DESCRIPTION	FUNCTION	JAN AND NAVY TYPE NO.	STOCK NO. STANDARD NAVY	MFGR. & MFGS. DESIG- NATION	CON- TRACTOR DWG. & PART NO.	ALL SYMBOLS DESIGNATION INVOLVED	PARTS							
								TOTAL ON PER EQUIP.	ITEM NO.	EQUIP		TEN- DER		STOCK	
										QUAN.	BOX	QUAN.	BOX	QUAN.	BOX
J-503	Jack, telephone; single circuit for 0.25" diameter plug 1 $\frac{3}{16}$ " long	Receiver phones jack	49025B	For Replacement use N17-J-39209-8020	Switchcraft	110954	J-503, J-904 J-905	3		0					
J-504	Connector, female contact; 7 cylindrical contacts, phenolic insulated; input end at right angles to the output	Interconnecting cable connector on receiver end of W-101 to P-504			Amphenol AN-3108A-24-3S(6-4M)	110770	J-504	1		0					
J-505	Lampholder; miniature bayonet base with sp. angle bracket; two 4-40 handles, $\frac{5}{16}$ " between centers	Holder for I-501		N17-L-51623-3790	Dial Light Co. America, Spcl.	120316	J-505, J-506	2		0			20		
J-506	Lampholder; same as J-505	Holder for I-502													
J-901	Connectors, female contact; 3 cylindrical contacts melamine insulated	AC line cable connector to P-901 on power supply		N17-70328-8589	Amphenol AN-3106-A-18-22S(6-4M)	110768	J-901	1		0					
J-902	Connector, female contacts; 4 cylindrical contacts, melamine insulated	Speaker cable connector on power amplifier, power supply to P-902 on speaker cable		N17-C-72247-3125	Amphenol AN-3102A-18-4S	110764	J-902	1		0					
J-903	Connector, female contact; 7 cylindrical contacts melamine insulated	Interconnecting cable connector on power amplifier power supply to P-903 on cable W-101		N17-C-72260-6714	Amphenol AN-3102A-24-3S	110763	J-903	1		0					
J-904	Jack telephone; same as J-503	Rectifier power amplifier unit phones													
J-905	Jack telephone; same as J-503	Rectifier power amplifier unit phones													
J-906	Lampholder, pilot lamp assembly in power supply; composed of J-906A and J-906B	Power ON-OFF indicator			Dial Light Co. of America 810B-431	110953	J-906	1		0					
J-906A	Lampholder, body			For Reference Only											
J-906B	Lampholder, lens			For Reference Only											

TABLE 8-4. COMBINED PARTS & SPARE PARTS LIST — CONTINUED

PARTS								SPARE PARTS						
SYM- BOL DESIG.	NAME OF PART AND DESCRIPTION	FUNCTION	JAN AND NAVY TYPE NO.	STOCK NO. STANDARD NAVY	MFGR. & MFGRS. DESIG- NATION	CON- TRACTOR DWG. & PART NO.	ALL SYMBOLS DESIGNATION INVOLVED	TOTAL ON PER EQUIP.	EQUIP		TEN- DER		STOCK	
									ITEM NO.	QUAN. BOX	QUAN. BOX	QUAN. BOX		
L-501	Coil, RF antenna, band-pass; primary: Universal winding 28½ turns No. 36 AWG SSE copper wire; secondary solenoid winding 8 turn No. 20 AWG soft silver wire	Antenna tuning Band 4			The Sealtron Co.	220376-A	L-501	1	1	1			44	
L-502	Coil, RF antenna; band-pass; primary: Universal winding 31½ turns No. 36 AWG SSE copper wire; secondary solenoid winding 14½ turns No. 24 AWG En. copper wire	Antenna tuning Band 3			The Sealtron Co.	220377-A	L-502	1	2	1			44	
L-503	Coil, RF antenna; band-pass; primary: Universal winding 78½ turns No. 36 AWG En. copper wire; secondary: solenoid winding 28 turns of 19 stranded No. 44 SWG SSE Litz wire	Antenna tuning Band 2			The Sealtron Co.	220378-A	L-503	1	3	1			44	
L-504	Coil, RF antenna; band-pass; primary: Universal winding 144 turns No. 38 AWG SSE copper wire; secondary Universal winding 37 turns of 30 stranded No. 44 AWG SSE Litz wire	Antenna tuning Band 1			The Sealtron Co.	220379-A	L-504	1	4	1			44	
L-505	Coil, RF; RF transformer; primary; solenoid winding 2⅓ turn No. 28 AWG En. copper wire; secondary: solenoid winding 8 turns No. 20 AWG soft solid silver wire	RF plate tuning Band 4			The Sealtron Co.	220380-1	L-505	1	5	1			44	
L-506	Coil, RF; RF transformer; primary; solenoid winding 12⅓ turns No. 28 AWG En. copper wire; secondary; solenoid winding 14 turns No. 24 AWG En. copper wire	RF plate tuning Band 3			The Sealtron Co.	220381-A	L-506, L-510	2	6	2			88	

TABLE 8-4. COMBINED PARTS & SPARE PARTS LIST — CONTINUED

SYM- BOL DESIG.	NAME OF PART AND DESCRIPTION	FUNCTION	JAN AND NAVY TYPE NO.	STOCK NO. STANDARD NAVY	MFGR. & MFGRS. DESIG- NATION	CON- TRACTOR DWG. & PART NO.	ALL SYMBOLS DESIGNATION INVOLVED	SPARE PARTS							
								TOTAL ON PER EQUIP.	ITEM NO.	EQUIP		TEN- DER		STOCK	
										QUAN.	BOX	QUAN.	BOX	QUAN.	BOX
L-507	Coil RF; RF transformer primary; solenoid winding $2\frac{2}{3}$ turns No. 32 AWG En. copper wire; secondary universal winding; 21 turns 30 strands No. 44 AWG SSE Litz wire	RF tuning plate Band 2			The Sealtron Co.	220382-A	L-507, L-511	2	7	2				88	
L-508	Coil, RF; RF transformer; primary: solenoid winding $4\frac{2}{3}$ turns No. 32 AWG En. copper wire secondary: Universal winding 38 turns 7 stranded No. 41 AWG SSE Litz wire	RF plate tuning			The Sealtron Co.	220383-1	L-508	1	8	1				44	
L-509	Coil, RF same as L-505 except for slight difference in "Q" characteristics	Converter grid tuning, Band 4				220380-2	L-509	1	15	1				44	
L-510	Coil, RF same as L-506	Converter grid tuning, Band 3													
L-511	Coil, RF same as L-507	Converter grid tuning, Band 2													
L-512	Coil, RF same as L-508 except for slight differences in "Q" characteristics	Converter grid tuning, Band 1				220383-2	L-512	1	16	1				44	
L-513	Coil, RF; oscillator; solenoid winding $7\frac{1}{2}$ turns; tapped at $2\frac{1}{2}$ and 5 turns; No. 24 AWG En. copper wire	Heterodyne oscillator Band 4			The Sealtron Co.	220384-A	L-513	1	9	1				44	
L-514	Coil, RF; oscillator; solenoid winding $13\frac{1}{2}$ turns; tapped $3\frac{1}{2}$ and 10 turns No. 24 AWG En. copper wire	Heterodyne oscillator Band 3			The Sealtron Co.	2220385-A	L-514	1	10	1				44	
L-515	Coil, RF; oscillator; solenoid winding $25\frac{1}{4}$ turns; tapped at $7\frac{1}{2}$ and 15 turns; No. 24 AWG copper wire	Heterodyne oscillator Band 2			The Sealtron Co.	220386-A	L-515	1	11	1				44	

ORIGINAL

TABLE 8-4. COMBINED PARTS & SPARE PARTS LIST — CONTINUED

SYM- BOL DESIG.	NAME OF PART AND DESCRIPTION	FUNCTION	JAN AND NAVY TYPE NO.	STOCK NO. STANDARD NAVY	MFGR. & MFGRS. DESIG- NATION	CON- TRACTOR DWG. & PART NO.	ALL SYMBOLS DESIGNATION INVOLVED	PARTS							
								TOTAL ON PER EQUIP.	ITEM NO.	EQUIP		TEN- DER		STOCK	
										QUAN. BOX	QUAN. BOX	QUAN. BOX	QUAN. BOX		
L-516	Coil, RF; oscillator; sole- noid winding 34½ turns; tapped at 9½ and 15 turns; No. 30 AWG En. copper wire	Heterodyne oscillator Band 1			The Sealtron Co.	220387-A	L-516	1	12	1				44	
L-517	Coil, IF; transformer pri- mary; universal winding 90 turns; wound in two Pi with 30 stranded No. 44 AWG SSE Litz wire; secondary; universal winding 90 turns; two Pi wound with a tap at 45 turns; using 30 stranded No. 44 AWG SSE Litz wire; tertiary; random winding 6½ turns No. 36 AWG DDC wire	1st IF coil	47420	N17-T-82062-9981	F. W. Sickles	220566-A	L-517	1	13	1					
L-518	Coil, IF; transformer; pri- mary universal winding 90 turns; two Pi wound with 30 stranded No. 44 AWG SSE Litz wire; secondary; universal wiring 90 turns; two Pi wound with a tap at 45 turns using 30 stranded No. 44 AWG SSE Litz wire; tertiary; random winding 7½ turns No. 36 AWG DCC wire	2nd IF coil	47429		F. W. Sickles	220567-A	L-518	1	14	1				50	
L-519	Coil, IF transformer pri- mary; universal winding 90 turns; two Pi wound with 30 stranded No. 44 AWG SSE Litz wire; secondary univer- sal winding 90 turns two Pi wound with a tap at 68 turns; using 30 stranded No. 44 AWG SSE Litz wire	3rd IF coil	47430	N17-T-67740-4508	F. W. Sickles	220568-A	L-519	1	17	1					

ORIGINAL

8-17

PARTS LIST

NAVSHIPS 91944
RBS-3

Section 8
L-516—L-519

TABLE 8-4. COMBINED PARTS & SPARE PARTS LIST — CONTINUED

SYM- BOL DESIG.	NAME OF PART AND DESCRIPTION	FUNCTION	JAN AND NAVY TYPE NO.	STOCK NO. STANDARD NAVY	MFG. & MFGRS. DESIG- NATION	CON- TRACTOR DWG. & PART NO.	ALL SYMBOLS DESIGNATION INVOLVED	PARTS								
								TOTAL ON PER EQUIP.		EQUIP		TEN- DER		STOCK		
								ITEM NO.	QUAN.	QUAN.	BOX	QUAN.	BOX	QUAN.	BOX	
L-520	Coil, RF; oscillator; uni- versal winding; 68 turns No. 36 AWG wound in two Pi's tapped at 12½ turns	Beat frequency oscillator	47428	N16-C-73537-9308	F. W. Sickles	220569-A	L-520	1	18	1						
L-521	Filter Assembly; low pass; coil 7.5 henries at 0.9 m.s. DC; 6500 turns No. 42 En. copper wire; 2300 ohms D.C. resistance; capacitor 75 mmf ±2% 500 VDCW	Low pass filter 1st IF			Audio Devel. Co. A-7019	120347	L-521, L-522	2	19	1				50		
L-522	Filter Assembly; low pass same as L-521	Low pass filter 1st IF														
L-901	Reactor; 50 henries ±10% 10 volts; 60 cps and 165 ma; DC resist- ance 97 ohms	Filter choke, power supply		N16-R-29486-1865	Audio Devel. Co. A-7020	120329	L-901, L-902	2	20	1				50		
L-902	Reactor; same as L-901	Filter choke, power supply														
N-101	Book, instruction	Operating instructions		Shop Manufacture	The Sealtron Co.		N-101									
O-501	Not used															
O-502	Coupling, flexible phenolic insulated	Ant. compensator coupling			Bud Mfg. Co. No. FC-855	110478	O-502	1		0						
O-503	Coupling, flexible steatite insulated	Tuning condenser coupling		N17-C-98378-4426	Millen Co. No. 39009	110579	O-503	1		0						
O-504	Shaft Assembly, flexible	B.F.O. Vernier coupling			Z&W Machine	200222-A	O-504	1		0				20		
O-505	Coupling, rigid	Selectivity switch to shaft coupling		Shop Manufacture	Z&W Machine	100230	O-505	1		0						
O-506	Spring, tension	Vernier idler gear anti-backlash			Wakefield	100132	O-506, O-508	4		0				100		
O-507	Spring, compression	Dial gear, anti- backlash			Wakefield	100128	O-507	2		0				50		
O-508	Spring, tension, same as O-506	Condenser gear anti-backlash														
O-509	Spring, tension	Stop arm tension			Wakefield	100142	O-509	2		0				50		
O-510	Spring, tension	Detent tension			Wakefield	100141	O-510	1		0				50		

ORIGINAL

TABLE 8-4. COMBINED PARTS & SPARE PARTS LIST — CONTINUED

SYM- BOL DESIG.	NAME OF PART AND DESCRIPTION	FUNCTION	JAN AND NAVY TYPE NO.	STOCK NO. STANDARD NAVY	MFGR. & MFGRS. DESIG- NATION	CON- TRACTOR DWG. & PART NO.	ALL SYMBOLS DESIGNATION INVOLVED	SPARE PARTS										
								TOTAL ON PER EQUIP.	ITEM NO.	EQUIP		TEN- DER		STOCK				
										QUAN. BOX	QUAN. BOX	QUAN. BOX	QUAN. BOX					
O-511	Lever, dial lock			Shop Manufacture	The Sealtron Co.	100580	O-511	1										
P-504	Connector, male contact 7 cylindrical contact phenolic	Receiver power input and audio on rear of receiver, con- nects with J-504 on interconnecting cable W-101		N17-C-72624-6365	Amphenol AN-3102A-24- 3P(02-4M)	110766	P-504	1										
P-501	Connector, male contact 3 cylindrical contact	AC line connector on rear of rectifier power amplifier, connects to J-901		N17-C-72604-8583	Amphenol AN-3102A- 18-22P	110765	P-901	1										
P-902	Connector, male contact 4 cylindrical contacts	Audio output con- nector on speaker cable connects to J-902		For Replacement use N17-C-70595-3132	Amphenol AN-3106A- 18-4P	110767	P-902	1										
P-903	Connector, male contact	Plug on cable W-101 connecting to J-903 of rectifier power amplifier		N17-C-70608-6365	Amphenol AN-3106A- 24-3P	110769	P-903	1										
R-501	Resistor, fixed; composi- tion; .47 megohms; $\pm 10\%$; $\frac{1}{2}$ watt	Bleeder, antenna	RC-20BE474K 63360-474	For Replacement use N16-R-50822-811	International Resistor Co. type BTS	110581-1	R-501, R-535 R-541, R-547 R-573	5										
R-502	Resistor, fixed; composi- tion; .1 megohms; $\pm 10\%$; $\frac{1}{2}$ watt	Filter, RF AVC	RC20BF104K 63360-104	N16-R-50633-811	IRC BTS	110581-2	R-502, R-518 R-522, R-538	4										
R-503	Resistor, fixed; composi- tion; .43 megohms; $\pm 5\%$; $\frac{1}{2}$ watt	Screen dropping 1st AF	RC20BE434J 63355-434	For Replacement use N16-R-50803-431	IRC BTS	110581-3	R-503	1										
R-504	Resistor, fixed; composi- tion; 4700 ohms; $\pm 10\%$; $\frac{1}{2}$ watt	Screen dropping RF	RC20BE472K 63360-472	For Replacement use N16-R-50129-811	IRC BTS	110581-4	R-504, R-520 R-524	3										
R-505	Resistor, fixed; composi- tion; 2200 ohms $\pm 10\%$; $\frac{1}{2}$ watt	Filter, RF plate	RC20BE222K 63360-222	For Replacement use N16-R-50012-811	IRC BTS	110581-5	R-505, R-516 R-517, R-521 R-525	5										
R-506	Resistor, fixed; composi- tion; 10 ohms $\pm 10\%$; $\frac{1}{2}$ watt	Filter, RF cathode	RF20BE100K 63360-100	For Replacement use N-16-R-49238-811	IRC BTS	110581-6	R-506	1										
R-510	Resistor, fixed; composi- tion; ceramic case 2.2 megohms $\pm 10\%$; $\frac{1}{2}$ watt	Leak, RF grid		N16-R-51065-811	IRC BTS	110581-32	R-510, R-548 R-570, R-571	4										

8-20

TABLE 8-4. COMBINED PARTS & SPARE PARTS LIST — CONTINUED

SYM- BOL DESIG.	NAME OF PART AND DESCRIPTION	FUNCTION	PARTS					SPARE PARTS							
			JAN AND NAVY TYPE NO.	STOCK NO. STANDARD NAVY	MFGR. & MFGRS. DESIG- NATION	CON- TRACTOR DWG. & PART NO.	ALL SYMBOLS DESIGNATION INVOLVED	TOTAL ON HAND PER EQUIP.	ITEM NO.	EQUIP		TEN- DER		STOCK	
										QUAN.	BOX	QUAN.	BOX	QUAN.	BOX
R-511	Resistor, fixed; composi- tion; 1500 ohms $\pm 10\%$; $\frac{1}{2}$ watt	Bias converter cathode	RC20BE152K 63360-152	For Replacement use N16-R-49967-811	IRC BTS	110581-8	R-511	1	0						
R-512	Resistor, fixed; composi- tion; 68,000 ohms $\pm 10\%$; $\frac{1}{2}$ watt	Screen dropping converter	RC20BE683K 63360-683	For Replacement use N16-R-50552-811	IRC BTS	110581-9	R-512	1	0						
R-513	Resistor, fixed; composi- tion; .22 megohm $\pm 10\%$; $\frac{1}{2}$ watt	Load, 2nd AF plate	RC20BE224K 63360-224	For Replacement use N16-R-50714-811	IRC BTS	110581-10	R-513, R-526 R-527	3	0						
R-514	Resistor, fixed; composi- tion; 20,000 ohms $\pm 5\%$; $\frac{1}{2}$ watt	Leak osc. grid	RC20BE203J 63360-203	For Replacement use N16-R-50362-431	IRC	110581-11	R-514	1	0						
R-515	Resistor, fixed; composi- tion; 33,000 ohms $\pm 10\%$; $\frac{1}{2}$ watt	Screen dropping osc.	RC20BE333K 63360-333	For Replacement use N16-R-50417-811	IRC BTS	110581-12	R-515	1	0						
R-516	Resistor, same as R-505	Filter osc. plate													
R-517	Resistor, same as R-505	Filter converter plate													
R-518	Resistor, same as R-502	Filter, 1st IF AGC													
R-519	Resistor, fixed; composi- tion, ceramic case; .47 megohm $\pm 10\%$; $\frac{1}{2}$ watt	Filter AGC	RC21BE474K	For Replacement use N16-R-50822-811	IRC	110581-13	R-519, R-523	2	0						
R-520	Resistor, same as R-504	Screen dropping 1st IF													
R-521	Resistor, same as R-505	Filter, 1st IF plate													
R-522	Resistor, same as R-502	Filter, converter AGC													
R-523	Resistor, same as R-519	Load and filter AGC diode													
R-524	Resistor, same as R-504	Screen dropping 2nd IF													
R-525	Resistor, same as R-505	Filter 2nd IF plate													
R-526	Resistor, same as R-513	Filter signal diode													
R-527	Resistor, same as R-513	Load signal diode													
R-528	Resistor, fixed; composi- tion; 1 megohm $\pm 10\%$	Return noise peak limiter	RC20BE105K 63360-105	For Replacement use N16-R-50975-811	IRC BTS	110581-14	R-528, R-536 R-562	3	0						

ORIGINAL

Section
8
R-511—R528NAVSHIPS 91944
RBS-3

PARTS LIST

ORIGINAL

TABLE 8-4. COMBINED PARTS & SPARE PARTS LIST — CONTINUED

SYM- BOL DESIG.	NAME OF PART AND DESCRIPTION	FUNCTION	PARTS					SPARE PARTS						
			JAN AND NAVY TYPE NO.	STOCK NO. STANDARD NAVY	MFGR. & MFGRS. DESIG- NATION	CON- TRACTOR DWG. & PART NO.	ALL SYMBOLS DESIGNATION INVOLVED	TOTAL ON PER EQUIP.	EQUIP		TEN- DER		STOCK	
									ITEM NO.	QUAN. BOX	QUAN. BOX	QUAN. BOX		
R-529	Resistor, fixed; composi- tion; 15,000 ohms $\pm 10\%$; $\frac{1}{2}$ watt	Bias 2nd AF cathode	RC20BE153K 63360-153	For Replacement use N16-R-50336-811	IRC BTS	110581-15	R-529	1	0					
R-530	Resistor, fixed; composi- tion; 1000 ohms $\pm 5\%$; $\frac{1}{2}$ watt	Bias 1st AF cathode	RC20BE102J 63355-102	For Replacement use N16-R-49921-431	IRC BTS	110581-16	R-530	1	0					
R-531	Resistor, fixed; composi- tion .39 megohm $\pm 10\%$; $\frac{1}{2}$ watt	Load, AGC diode	RC20BE394K 63360-394	For Replacement use N16-R-50786-811	IRC BTS	110581-17	R-531	1	0					
R-532	Resistor, fixed; composi- tion 3,000 ohms $\pm 5\%$; $\frac{1}{2}$ watt	Delay, AGC diode	RC20BE302J 63355-302	For Replacement use N16-R-50047-431	IRC BTS	110581-18	R-532	1	0					
R-533	Resistor, variable; compo- sition composed of R-533A and R-533B			N16-R-88999-9180		120460	R-533	1	0					
R-533A	Resistor, variable; part of R-533, 7,500 ohms $\pm 10\%$ 2 watt log taper	Output level control 2nd AF plate and screen control (operation with reception control on "OL")		For Reference Only										
R-533B	Resistor, variable; compo- sition, 1 megohm $\pm 10\%$ 2 watt log taper part of R-533	Output level control 1st AF signal volt- age control (oper- ation with "Recep- tion" control on "AGC", "MOD" and "CW")		For Reference Only										
R-534	Resistor, fixed; composi- tion; 620 ohms	Bias, 3rd AF cathode	RC20BE621J 63355-621	For Replacement use N16-R-49822-431	IRC BTS	110581-19	R-534	1	0					
R-535	Resistor, same as R-501 $\pm 5\%$; $\frac{1}{2}$ watt	Leak, 3rd AF grid												
R-536	Resistor, same as R-528	Current limiter, 2nd AF grid												
R-537	Resistor, variable; compo- sition 2000 ohms $\pm 10\%$; 2 watt special taper	RF & IF gain control		N16-R-87419-4201	Allen Bradley special	120462	R-537	1	21	1		50		
R-538	Resistor, same as R-502	Load, 1st AF plate												

PARTS LIST

NAVSHIPS 91944
RBS-3Section
8
R-529—R-538

8-21

TABLE 8-4. COMBINED PARTS & SPARE PARTS LIST — CONTINUED

SYM- BOL DESIG.	NAME OF PART AND DESCRIPTION	FUNCTION	JAN AND NAVY TYPE NO.	STOCK NO. STANDARD NAVY	MFGR. & MFGRS. DESIG- NATION	CON- TRACTOR DWG. & PART NO.	ALL SYMBOLS DESIGNATION INVOLVED	TOTAL ON PER EQUIP.	SPARE PARTS						
									ITEM NO.	EQUIP		TEN- DER		STOCK	
										QUAN.	BOX	QUAN.	BOX	QUAN.	BOX
R-539	Resistor, fixed; composi- tion; 10,000 ohms $\pm 10\%$ $\frac{1}{2}$ watt	Filter CW osc.	RC20BE103K 63360-103	For Replacement use N16-R-50282-811	IRC BTS	110581-20	R-539, R-550	2	0						
R-540	Resistor, fixed; composi- tion, 47,000 ohms $\pm 10\%$ $\frac{1}{2}$ watt	Load CW osc. plate	RC20BE473K 63360-473	For Replacement use N16-R-50480-811	IRC BTS	110581-21	R-540, R-542 R-565, R-566	4	0						
R-541	Resistor, same as R-501	Screen dropping CW osc.													
R-542	Resistor, same as R-540	Leak CW osc. grid													
R-543	Resistor, fixed; composi- tion; 10,000 ohms $\pm 10\%$ 2 watt	Bleeder plate to screen bus	RC41BE103K	For Replacement use N16-R-50283-535	IRC BTS	110581-22	R-543, R-572	2	0						
R-544	Resistor, fixed; composi- tion; 30,000 ohms $\pm 5\%$	Bleeder screen bus to gain control	RC41BE303J	For Replacement use N16-R-50408-140	IRC BTS	110581-23	R-544, R-576	2	0						
R-545	Resistor, fixed; composi- tion, .15 megohm $\pm 5\%$ $\frac{1}{2}$ watt	Delay supply (AVC)	RC20BE154J 63355-154	For Replacement use N16-R-50677-431	IRC BTS	110581-24	R-545, R-575	2	0						
R-546	Resistor, variable; compo- sition; 50 ohms $\pm 10\%$ 2 watt	Dial light dimmer	CBZ631217-10		Allen Bradley CBZ-631217	120463	R-548	1	0						
R-547	Resistor, same as R-501	Leak, 2nd AF grid													
R-548	Resistor, same as R-510	Leak, converter grid													
R-549	Resistor, fixed; composi- tion; .68 megohms $\pm 10\%$ $\frac{1}{2}$ watt.	Load, noise peak limiter	RC20BE684K 63360-684	For Replacement use N16-R-50894-811	IRC BTS	110581-25	R-549	1	0						
R-550	Resistor, same as R-539	Filter 1st AF plate													
R-551	Resistor, fixed; wire wound 75 ohms $\pm 5\%$ $\frac{1}{2}$ watt	Bias RF cathode	RU3C750J	N16-R-68349-7911	IRC BW	110581-26	R-551	1	0						
R-552	Resistor, fixed; composi- tion; 510 ohms $\pm 5\%$; $\frac{1}{2}$ watt	Load osc. plate	RC20BE511J 63355-511	For Replacement use N16-R-49786-431	IRC BTS	110581-27	R-552, R-577	2	0						
R-558	Resistor, fixed; wire wound 150 ohms $\pm 10\%$ $\frac{1}{2}$ watt	Bias 1st IF cathode	RU3C151K 63678-151	For Replacement use N16-R-68363-1666	IRC BW	110581-28	R-558, C-568	2	0						
R-562	Resistor, same as R-528	CW audio divider													
R-563	Resistor, fixed; composi- tion; 20,000 ohms $\pm 5\%$ 1 watt	Filter, 3rd AF plate and screen	RC30BE203J 63288-203	For Replacement use N16-R-50362-751	IRC BTA	110581-29	R-563, R-564	2	0						

ORIGINAL

ORIGINAL

TABLE 8-4. COMBINED PARTS & SPARE PARTS LIST — CONTINUED

PARTS LIST

NAVSHIPS 91944
RBS-3Section 8
R-564—R-904

SYM- BOL DESIG.	NAME OF PART AND DESCRIPTION	FUNCTION	PARTS					SPARE PARTS									
			JAN AND NAVY TYPE NO.	STOCK NO. STANDARD NAVY	MFGR. & MFGRS. DESIG- NATION	CON- TRACTOR DWG. & PART NO.	ALL SYMBOLS DESIGNATION INVOLVED	TOTAL ON PER EQUIP.	ITEM NO.	EQUIP		TEN- DER		STOCK			
										QUAN.	BOX	QUAN.	BOX	QUAN.	BOX		
R-564	Resistor, same as R-563	Filter, 3rd AF plate and screen															
R-565	Resistor, same as R-540	Screen dropping 2nd AF															
R-566	Resistor, same as R-540	Filter, 2nd AF plate															
R-567	Resistor, fixed; composition; 22,000 ohms ±5%; 1/2 watt	Feedback, 3rd AF to 2nd AF	RC20BE223J 63355-223	For Replacement use N16-R-50371-431	IRC BRS	110581-30	R-567	1		0							
R-568	Resistor, same as R-558	Bias 2nd IF cathode															
R-569	Resistor, fixed; composition; .33 megohms ±10%; 1/2 watt	Series resistance output level cont.	RC20BE334K 63360-334	For Replacement use N16-R-50759-811	IRC BTS	110581-31	R-569	1		0							
R-570	Resistor, same as R-510	Leak, 2nd IF grid															
R-571	Resistor, same as R-510	Leak, 1st AF grid															
R-572	Resistor, same as R-543	Bleeder, plate to screen															
R-573	Resistor, same as R-501	Load and filter AVC diode															
R-575	Resistor, same as R-545	Delay supply AVC															
R-576	Resistor, same as R-544	Bleeder, screen B+ to gain control															
R-577	Resistor, same as R-552	Bias fixed in gain control R-537															
R-901	Resistor, fixed; wire wound; 10,000 ohms ±5%; 40 watt ferrule terminals	Bleeder voltage divider	RW14G103	For Replacement use N16-R-62072-1995	Sprague	110581-37	R-901, R-903	2		0							
R-902	Resistor, fixed; wire wound; 710 ohms ±5%; 14 watt ferrule terminals	Filter, +B	RW16G711		Sprague	110581-38	R-902	1		0							
R-903	Resistor, fixed; wire wound; same as R-901	Audio limiting															
R-904	Resistor, fixed; wire wound; 200 ohms ±5%; 2 watt	Power amplifier bias	RU6B201J	N16-R-49706-5046	IRC BW-2	110581-39	R-904	1		0							

8-23

TABLE 8-4. COMBINED PARTS & SPARE PARTS LIST — CONTINUED

SYM- BOL DESIG.	NAME OF PART AND DESCRIPTION	FUNCTION	JAN AND NAVY TYPE NO.	STOCK NO. STANDARD NAVY	MFRG. & MFRS. DESIG- NATION	CON- TRACTOR DWG. & PART NO.	ALL SYMBOLS DESIGNATION INVOLVED	SPARE PARTS							
								TOTAL ON PER EQUIP.	ITEM NO.	EQUIP		TEN- DER		STOCK	
										QUAN.	BOX	QUAN.	BOX	QUAN.	BOX
R-905	Resistor, variable compo- sition, 900 ohms $\pm 20\%$; 2 watt special taper	Headphone level		N16-R-87332-5306	A. Bradley D-5948	120374	R-905	1		0					
R-906	Resistor, fixed; composi- tion, 330 ohms $\pm 10\%$; 1/2 watt	Headphone control circuit	RC20BE331K 63360-331	For Replacement use N16-R-49706-811	IRC BTS	110581-36	R-906	1		0					
S-501	Switch, rotary; 8 wafer listed for reference only			Assemble from component parts			S-501								
S-501A	Switch, rotary; wafer type, single pole, 4 position; silver plated contacts	Band switch section antenna primary		N16-S-16083-33	P. R. Mallory	120520	S-501A, S-501B S-501C, S-501D S-501F	5	22	2					
S-501B	Switch, rotary; same as S-501A	Band switch section antenna secondary													
S-501C	Switch, rotary; same as S-501A	Band switch RF plate coils													
S-501D	Switch, rotary; same as S-501A	Band switch section conv. grid.													
S-501E	Switch, rotary; wafer type, double pole, 4 position, silver plate contacts	Band switch section osc. coils and padders		N16-S-16083-22	P. R. Mallory	120519	S-501E	1	23	1					
S-501F	Switch, rotary; same as S-501A	Band switch section osc. grid													
S-501G	Switch, rotary; wafer type, double pole 4 position; silver plated contacts	Band switch section osc. cathode and padders		N16-S-16083-11	P. R. Mallory	120518	S-501G	1	24	1					
S-501H	Switch, rotary; wafer type, single pole 4 position; silver plated contacts	Band switch section shaft ground con- tactor		N16-S-16083-44	P. R. Mallory	220781-A	S-501H	1	25	1					
S-502	Switch, rotary; 2 wafer type; composed of S-502A and S-502B			N16-S-64316-3017	P. R. Mallory	220255	S-502	1	26	1					
S-502A	Switch, rotary; wafer type; double pole; 2 position, silver plated contacts part of S-502	1st IF selectivity switch		For Reference Only			S-502A, S-502B								
S-502B	Switch, rotary; same as S-502A	2nd IF selectivity switch													

TABLE 8-4. COMBINED PARTS & SPARE PARTS LIST — CONTINUED

ORIGINAL

PARTS LIST

PARTS								SPARE PARTS							
SYM-BOL DESIG.	NAME OF PART AND DESCRIPTION	FUNCTION	JAN AND NAVY TYPE NO.	STOCK NO. STANDARD NAVY	MFGR. & MFGRS. DESIGNATION	CONTRACTOR DWG. & PART NO.	ALL SYMBOLS DESIGNATION INVOLVED	TOTAL ON PER EQUIP.	ITEM NO.	EQUIP		TENDER		STOCK	
										QUAN.	BOX	QUAN.	BOX	QUAN.	BOX
S-503	Switch, rotary; 2 wafer; composed of S-503A and S-503B				P. R. Mallory	220254	S-503	1	27	1				60	
S-503A	Switch, rotary; wafer type; 7 pole, 4 position; silver plated contacts	Reception control for the B.F.O.; output AVC delay 2nd AF screen and plate supply					S-503A, S-503B								
S-503B	Switch, rotary; same as S-503A	Reception control for AVC and audio input to 1st AF													
S-504	Switch, toggle; single pole double throw	Noise limiter	24113		For Replacement use N16-S-71981-7519	Carling Elec. Inc. 112/7/16	S-504	1		0					
S-901	Switch, toggle; single pole; single throw; 3 amps; 250 volts	Power, on-off			N17-S-71981-7519	Carling Elec. Inc. 110-5/16	S-901	1		0					
T-501	Transformer Assembly; Antenna, consisting of 4 coils, 6 fixed capacitors, 4 variable capacitors, 1 fixed resistor, and 1 band switch	Antenna transformer			*	The Sealtron Co.	400429A	T-501	1	28	1			60	
T-502	Transformer Assembly; RE, consisting of 8 coils, 10 fixed capacitors, 8 variable capacitors, 1 fixed resistor and 1 band switch	RF transformer			*	The Sealtron Co.	400435A	T-502	1	29	1			60	
T-503	Transformer Assembly; oscillator, consisting of 4 coils, 9 fixed capacitors, 4 variable capacitors and 1 band switch	RF oscillatot			N16-O-66007-4939	The Sealtron Co.	400430A	T-503	1	30	1			44	
T-504	Transformer Assembly; IF consisting of 1 coil, 3 fixed capacitors, 2 two section variable capacitor and a fixed resistor, tuned to 1255 Kc.	1st IF transformer	47219		N17-T-67740-4639	F. W. Sickles	320432A	T-504	1	31	1				
T-505	Transformer Assembly; consisting of 1 coil, 3 fixed capacitors, a two section variable capacitor, and a fixed resistor tuned to 1255 Kc.	2nd IF transformer	47215		N17-T-67740-4659	F. W. Sickles	320434A	T-505	1	32	1				

*If required will be procured by nearest Naval Shore Supply Activity on demand.

NAVSHIPS 91944
RBS-3

Section 8
S-503-T-505

8-25

8-26

TABLE 8-4. COMBINED PARTS & SPARE PARTS LIST — CONTINUED

SYM- BOL DESIG.	NAME OF PART AND DESCRIPTION	FUNCTION	JAN AND NAVY TYPE NO.	STOCK NO. STANDARD NAVY	MFGRS. & MFGRS. DESIG- NATION	CON- TRACTOR DWG. & PART NO.	ALL SYMBOLS DESIGNATION INVOLVED	SPARE PARTS								
								TOTAL ON PER EQUIP.	ITEM NO.	EQUIP		TEN- DER		STOCK		
										QUAN.	BOX	QUAN.	BOX	QUAN.	BOX	
T-506	Transformer Assembly; IF consisting of 1 coil, two fixed capacitors, a two section variable capacitor, tuned to 1255 Kc.	3rd IF transformer	47213	N17-T-67740-4689	F. W. Sickles	320431A	T-506	1	33	1						
T-507	Transformer Assembly; B.F.O. consisting of a coil, 7 fixed capacitors, 2 variable capacitors, 4 fixed resistors tuned to 1256 Kc.	Beat frequency oscillator transformer	47217		F. W. Sickles	320433-A	T-507	1	34	1			60			
T-508	Transformer Receiver; output: ratio of primary to secondary 3700 to 965 turns current rating 185/20 ma. DC resistance 570/55 ohms wire size, No. 38/No. 32, voltage rating 74/10 AC RMS, frequency limits 200-3000. Primary inductance 7 henries includes electrostatic shield between primary and secondary	Audio output		N17-T-64658-4551	Audio Devel. Co. A-7018	120348	T-508	1	35	1						
T-901	Transformer, power; primary tapped for 105/115/125 volts single phase, 60 cy. Secondary: 6.3 CT/5.0 CT/770 CT volts at 3.35/3.0/0.165 amps; electrostatic shield between primary and secondary; case grounded	Filament and B+ supply		N17-T-73708-2387	Audio Devel. Co. A-7021	220346	T-901	1	36	1			80			
T-902	Transformer, Input Audio primary/secondary; turns ratio 550/1650 CT; DC resistance 9.8/108 ohms; wire size No. 28/32 AWG terminals 1-2/3-4/5	Input transformer		N17-T-61576-7052	Audio Devel. Co. A-7022	120330	T-902	1	37	1						

ORIGINAL

8 Section
T-506—T-902NAVSHIPS 91944
RBS-3

PARTS LIST

TABLE 8-4. COMBINED PARTS & SPARE PARTS LIST — CONTINUED

SYM- BOL DESIG.	NAME OF PART AND DESCRIPTION	FUNCTION	JAN AND NAVY TYPE NO.	STOCK NO. STANDARD NAVY	MFGR. & MFGRS. DESIG- NATION	CON- TRACTOR DWG. & PART NO.	ALL SYMBOLS DESIGNATION INVOLVED	PARTS								SPARE PARTS			
								TOTAL ON PER EQUIP.	ITEM NO.	EQUIP		TEN- DER		STOCK		QUAN.	BOX	QUAN.	BOX
										QUAN.	BOX	QUAN.	BOX	QUAN.	BOX				
T-903	Transformer output Audio; primary/secondary; impedance ratio 10,000/600 ohms turns ratio 2225 CT/550 CT; DC resistance 109/25 ohms wire size No. 32/No. 30 AWG; terminals 1-3/2/4-Case 5; includes electrostatic shield between primary and secondary grounded to case	Output transformer		N17-T-65498-4581	Audio Devel. Co. A-7023	120331	T-903	1	38	1									
U-501	Tuning Unit, RF	Tuning, band indicating, and dial mechanism		F16-D-46592-9790	The Sealtron Co.	400400A	U-501	1		0					2				
V-501	Tube, electron: RMA No. 6SG7, pentode	RF amplifier		N16-T-56655	RCA 6SG7	6SG7	V-501, V-502 V-504, V-505	4		0									
V-502	Tube, electron; same as V-501	Converter																	
V-503	Tube, electron: RMA No. 6SJ7, pentode	Heterodyne oscillator		N16-T-56665	RCA 6SJ7	6SJ7	V-503, V-508 V-510	3		0									
V-504	Tube, electron; same as V-501	1st IF amplifier																	
V-505	Tube, electron; same as V-501	2nd IF amplifier																	
V-506	Tube, electron: RMA No. 6H6, double diode	2nd detector and noise limiter		N16-T-56346	RCA 6H6	6H6	V-506, V-507	2		0									
V-507	Tube, electron; same as V-506	AVC diode																	
V-508	Tube, electron; same as V-503	CW oscillator																	
V-509	Tube, electron; RMA No. 6SK7, pentode	1st AF amplifier		N16-T-56670	Gen. Elec. 6SK7	6SK7	V-509	1		0									
V-510	Tube, electron; same as V-503	2nd AF amplifier																	
V-511	Tube, electron; RMA No. 6V6GT/G beam power pentode	3rd AF amplifier		N16-T-56758	Gen. Elec. 6V6GT/G	6V6 GT/G	V-511, V-902 V-903	3		0									

ORIGINAL

8-27

PARTS LIST

NAVSHIPS 91944
RBS-3

Section 8
T-903—V-511

TABLE 8-4. COMBINED PARTS & SPARE PARTS LIST — CONTINUED

SYM- BOL DESIG.	NAME OF PART AND DESCRIPTION	FUNCTION	JAN AND NAVY TYPE NO.	STOCK NO. STANDARD NAVY	MFGR. & MFGRS. DESIG- NATION	CON- TRACTOR DWG. & PART NO.	ALL SYMBOLS DESIGNATION INVOLVED	TOTAL ON PER EQUIP.	SPARE PARTS						
									ITEM NO.	EQUIP		TEN- DER		STOCK	
										QUAN.	BOX	QUAN.	BOX	QUAN.	BOX
V-901	Tube, electron; RMA No. 5U5G rectifier	Rectifier		N16-T-55464	Gen. Elec. 5U4G	5U4 G	V-901	1	0						
V-902	Tube, electron; same as V-511	Push-pull amplifier													
V-903	Tube, electron; same as V-511	Push-pull amplifier													
W-101A	Cable	Interconnection cable for power and AF to receiver				300785-A	W-101A	1	0						
W-101	Cable, assembly special purpose; AF and power with W-101A, J-504 and P-903	Interconnecting power supply and receiver units		Assemble from component parts		110496-5	W-101	1	0						
X-501	Socket, tube; octal replace- ment type steatite	RF amplifier	49373	For Replacement use N16-S-63524-6480	Amphenol 49RSS8	110178 X-503	X-501, X-502 X-503, X-504 X-505, X-506 X-507, X-508 X-509, X-510 X-511, X-901 X-902, X-903	14	0						
X-501A	Socket, shield; silver plated copper sheet .0148 thick	Grid shield		Shop Manufacture	The Sealtron Co.	100405	X-501A X-504A X-505A	3	0						
X-502	Socket, tube; same as X-501	Converter													
X-503	Socket, tube; same as X-501	Heterodyne oscillator													
X-504	Socket, tube; same as X-501	1st IF amplifier													
X-504A	Socket, shield; same as X-501A	Grid shield													
X-505	Socket, tube; same as X-501	2nd IF amplifier													
X-505A	Socket, shield; same as X-501A	Grid shield													
X-506	Socket, tube; same as X-501	2nd det. and noise limiter													

ORIGINAL

ORIGINAL

TABLE 8-4. COMBINED PARTS & SPARE PARTS LIST — CONTINUED

SYM- BOL DESIG.	NAME OF PART AND DESCRIPTION	FUNCTION	JAN AND NAVY TYPE NO.	STOCK NO. STANDARD NAVY	MFGR. & MFGRS. DESIG- NATION	CON- TRACTOR DWG. & PART NO.	ALL SYMBOLS DESIGNATION INVOLVED	TOTAL ON PER EQUIP.	SPARE PARTS											
									ITEM NO.	EQUIP		TEN- DER		STOCK						
										QUAN.	BOX	QUAN.	BOX	QUAN.	BOX					
X-507	Socket, tube; same as X-501	AVC diode																		
X-508	Socket, tube; same as X-501	Best frequency oscillator																		
X-509	Socket, tube; same as X-501	1st AF amplifier																		
X-510	Socket, tube; same as X-501	2nd AF amplifier																		
X-511	Socket, tube; same as X-501	3rd AF amplifier																		
X-901	Socket, tube; same as X-501	Rectifier																		
X-902	Socket, tube; same as X-501	Output amplifier																		
X-903	Socket, tube; same as X-502	Output amplifier																		

PARTS LIST

NAVSHIPS 91944
RBS-3Section 8
X-507—X-903

8-29

TABLE 8-5. CROSS REFERENCE PARTS LIST

JAN DESIGNATION	KEY SYMBOL	JAN DESIGNATION	KEY SYMBOL	NAVY TYPE	KEY SYMBOL	STANDARD NAVY STOCK NO.	KEY SYMBOL
CBZ631217-10	R-546	RC41BE303J	R-544	63360-104	R-502	F16-D-46592-9790	U-501
CC20HK020C	C-578	RU3C151K	R-558	63360-105	R-528	G17-F-16302-0100	F-901
CC20PH300J	C-532	RU3C750J	R-551	63360-152	R-511	G17-L-6297	I-501
CC20RH240G	C-531	RU6B201J	R-904	63360-153	R-529	G41-W-2445	H-505
CC20SH200J	C-529	RW14G103	R-901	63360-203	R-514	G41-W-2446	H-507
CM20B505M	C-583	RW16G711	R-902	63360-222	R-505	N16-C-16083-5836	C-529
CM20B101K	C-523			63360-224	R-513	N16-C-16211-6101	C-531
CM20B200J	C-589			63360-331	R-906	N16-C-24737-7903	C-567
CM20C121G	C-541			63360-333	R-515	N16-C-25107-8756	C-506
CM25B102K	C-597			63360-334	R-569	N16-C-25107-8756	C-583
CM30B302J	C-906			63360-394	R-531	N16-C-26025-8281	C584
CM35B103K	C-507			63360-434	R-503	N16-C-26442-8196	C-588
CM50B103K	C-599	24113	S-504	63360-472	R-504	N16-C-26732-9601	C-589
RC20BE100K	R-506	47213	T-506	63360-473	R-540	N16-C-27656-2601	C-554
RC20BE102J	R-530	47215	T-505	63360-474	R-501	N16-C-28558-1676	C-523
RC20BE103K	R-539	47217	T-507	63360-474	R-501	N16-C-28558-1676	C-523
RC20BE104K	R-502	47219	T-504	63360-683	R-512	N16-C-28732-5521	C-541
RC20BE105K	R-528	47420	L-517	63360-684	R-549	N16-C-29238-1123	C-571
RC20BE152K	R-511	47428	L-520	63678-151	R-558	N16-C-29819-2406	C-563
RC20BE153K	R-529	47429	L-518	481037-B10	C-580	N16-C-29866-2126	C-525
RC20BE154J	R-545	47430	L-519	481070-B10	C-597	N16-C-30447-1527	C-526
RC20BE203J	R-514	48591-B10	C-504	481223	C-524	N16-C-30531-4294	C-564
RC20BE222K	R-505	48674-B10	C-523	481464	C-513	N16-C-31090-4164	C-597
RC20BE223J	R-567	48771-B10	C-506	481465-B10	C-901	N16-C-31105-7677	C-527
RC20BE224J	R-513	48771-B20	C-583	481466	C-539	N16-C-31396-7014	C-528
RC20BE302J	R-532	48783-C5	C-589	481469	C-562	N16-C-32194-2494	C-906
RC20BE331K	R-906	48840-B7	C-588	481470A	C-575	N16-C-32720-7670	C-580
RC20BE333K	R-515	48895-B10	C-554	481482	C-560	N16-C-33622-5588	C-507
RC20BE334K	R-569	49025B	J-503	481483	C-902	N16-C-33623-3169	C-599
RC20BE394K	R-531	49120	E-521	481490-B5	C-563	N16-C-34514-5977	C-504
RC20BE434J	R-503	49121	J-501	481491-B5	C-564	N16-C-46702-9445	C-902
RC20BE472K	R-504	49151	J-502	481492-D2	C-525	N16-C-47272-9445	C-575
RC20BE473	R-540	49373	X-501	481494-D2	C-527	N16-C-47297-2870	C-524
RC20BE474K	R-501	63288-203	R-563	481495-D2	C-528	N16-C-48792-9198	C-562
RC20BE511J	R-552	63355-154	R-545	481496-C3	C-541	N16-C-49957-5925	C-903
RC20BE621J	R-534	63355-223	R-567	481497-B14	C-567	N16-C-53106-8805	C-513
RC20BE683K	R-512	63355-302	R-532	481498-D3	C-571	N16-C-53106-8815	C-560
RC20BE684K	R-546	63355-511	R-552	482501	C-540	N16-C-53148-7754	C-901
RC21BE474K	R-519	63355-621	R-534	482502	C-572	N16-C-54432-8720	C-539
RC30BE203J	R-563	63360-100	R-506	482505	C-573	N16-C-57980-1549	C-573
RC41BE103K	R-543	63360-102	R-530	482509	C-512	N16-C-58601-8939	C-501
		63360-103	R-539	487710-D10	C-584	N16-C-59025-5721	C-572

TABLE 8-5. CROSS REFERENCE PARTS LIST — CONTINUED

STANDARD NAVY STOCK NO.	KEY SYMBOL	STANDARD NAVY STOCK NO.	KEY SYMBOL	STANDARD NAVY STOCK NO.	KEY SYMBOL	ITEM NO.	KEY SYMBOL
N16-C-60952-2201	C-512	N16-R-68349-7911	R-551	N17-T-67740-4689	T-506	1	L-501
N16-C-62388-2962	C-540	N16-R-68363-1666	R-558	N17-T-3708-2387	T-901	2	L-502
N16-C-73537-9308	C-520	N16-R-87012-5388	R-546	N17-T-82062-9981	L-517	3	L-503
N16-C-300442-625	H-506	N16-R-87332-5306	R-905			4	L-504
N16-C-300798-621	H-902	N16-R-87419-4201	R-537			5	L-505
N16-C-300798-866	H-901	N16-R-88999-9180	R-533			6	L-506
N16-O-66007-4939	T-503	N16-S-16083-11	S-501G			7	L-507
N16-R-29486-1865	L-901	N16-S-16083-22	S-501E			8	L-508
N16-R-49238-811	R-506	N16-S-16083-33	S-501A			9	L-513
N16-R-49706-811	R-906	N16-S-16083-44	S-501H			10	L-514
N16-R-49706-5046	R-904	N16-S-63524-6480	X-501			11	L-515
N16-R-49786-431	R-552	N16-S-64316-3017	S-502			12	L-516
N16-R-49822-431	R-534	N16-S-71981-7519	S-504			13	L-517
N16-R-49921-431	R-530	N16-T-55464	V-901			14	L-518
N16-R-49967-811	R-511	N16-T-56346	V-506			15	L-509
N16-R-50012-811	R-505	N16-T-56655	V-501			16	L-512
N16-R-50047-431	R-532	N16-T-56665	V-503			17	L-519
N16-R-50129-811	R-504	N16-T-56670	V-509			18	L-520
N16-R-50282-811	R-539	N16-T-56778	V-511			19	L-521
N16-R-50283-535	R-543	N17-B-77536-1105	E-520			20	L-901
N16-R-50336-811	R-529	N17-C-67446-3796	J-502			21	R-537
N16-R-50362-431	R-514	N17-C-70328-8589	J-901			22	S-501A
N16-R-50362-751	R-563	N17-C-70595-3132	P-902			23	S-501E
N16-R-50371-431	R-567	N17-C-70608-6365	P-903			24	S-501G
N16-R-50408-140	R-544	N17-C-71120-4869	J-501			25	S-501H
N16-R-50417-811	R-515	N17-C-72247-3125	J-902			26	S-502
N16-R-50480-811	R-540	N17-C-72260-6174	J-903			27	S-503
N16-R-50552-811	R-512	N17-C-72604-8483	P-901			28	T-501
N16-R-50633-811	R-502	N17-C-72624-6365	P-504			29	T-502
N16-R-50677-431	R-545	N17-F-74267-6775	E-901			30	T-503
N16-R-50714-811	R-513	N17-J-39209-8020	J-503			31	T-504
N16-R-50759-811	R-569	N17-L-51623-3790	J-505			32	T-505
N16-R-50786-811	R-531	N17-M-75034-3431	A-504			33	T-506
N16-R-50803-431	R-503	N17-M-75051-3501	A-904			34	T-507
N16-R-50822-811	R-501	N17-S-71981-7519	S-901			35	T-508
N16-R-50822-811	R-519	N17-T-61576-7052	T-902			36	T-901
N16-R-50894-811	R-549	N17-T-64658-4551	T-508			37	T-902
N16-R-50975-811	R-528	N17-T-65498-4581	T-903			38	T-903
N16-R-51065-811	R-510	N17-T-67740-4508	L-519				
N16-R-62072-1995	R-901	N17-T-67740-4639	T-504				
		N17-T-67740-4659	T-505				

TABLE 8—6
APPLICABLE COLOR CODES
FOR
NAVY MODEL RBS-3
RADIO RECEIVING EQUIPMENT

RMA COLOR CODE FOR RESISTORS

COLOR	1st DIGIT	2nd DIGIT	DECIMAL MULTIPLIER	TOLERANCE
	A	B	C	D
Black	0	0	1	
Brown	1	1	10	
Red	2	2	100	
Orange	3	3	1,000	
Yellow	4	4	10,000	
Green	5	5	100,000	
Blue	6	6	1,000,000	
Violet	7	7	10,000,000	
Gray	8	8	100,000,000	
White	9	9	1,000,000,000	
Gold	—	—	0.1	±5%
Silver	—	—	0.01	±10%
No Color	—	—	—	±20%

ORIGINAL COLOR ARRANGEMENT FOR AXIAL LEADS

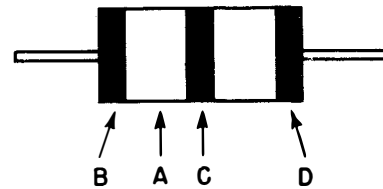

NEW COLOR ARRANGEMENT FOR AXIAL LEADS

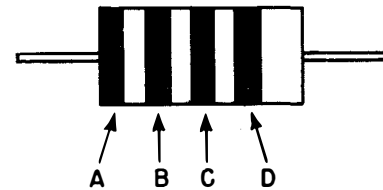

Example: If the order of the color bands from one end should be orange, blue, yellow and gold, the resistor value is 360,000 Ohms, ±5%.

RMA COLOR CODE FOR CAPACITORS IN MMFD

COLOR	1st DIGIT	2nd DIGIT	DECIMAL MULTIPLIER	TOLERANCE
	A	B	C	D
Black	0	0	1	—
Brown	1	1	10	±1%
Red	2	2	100	±2%
Orange	3	3	1,000	±3%
Yellow	4	4	10,000	±4%
Green	5	5	100,000	±5%
Blue	6	6	1,000,000	±6%
Violet	7	7	10,000,000	±7%
Gray	8	8	100,000,000	±8%
White	9	9	1,000,000,000	±9%
Gold	—	—	0.1	±5%
Silver	—	—	0.01	±10%
No Color	—	—	—	±20%

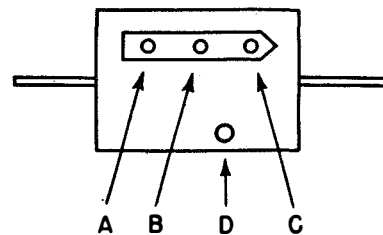

Example: 200 Micromicrofarads (.0002 Mfd) would have a red dot, a black dot and a brown dot, reading from left to right.

TABLE 8—6 (Cont'd)
APPLICABLE COLOR CODES
FOR
RADIO RECEIVING EQUIPMENT
RBS-3
TOLERANCE AND VOLTAGE RATINGS FOR CAPACITORS

RMA (M4-718) 6 DOT COLOR CODE

Capacitors are sometimes identified by a second (lower) row of three dots. The upper three indicates the digits of the Capacitance, and the lower right hand marker indicates the number of following ciphers. The middle marker of the lower three indicates the tolerance, and the lower left hand marker indicates the voltage rating.

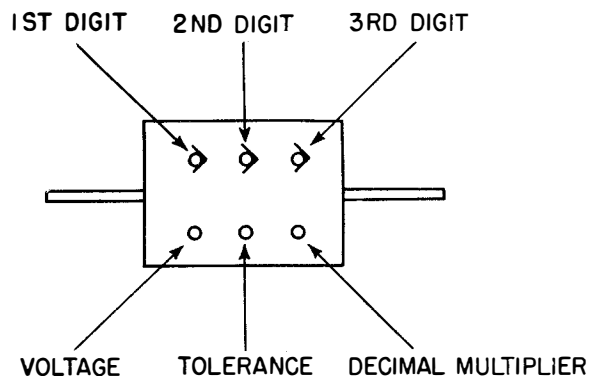

COLOR	SIGNIFICANT FIGURE	DECIMAL MULTIPLIER	TOLERANCE	VOLTAGE RATING
Black	0	1	—	—
Brown	1	10	±1 %	100 Volts
Red	2	100	±2 %	200 Volts
Orange	3	1,000	±3 %	300 Volts
Yellow	4	10,000	±4 %	400 Volts
Green	5	100,000	±5 %	500 Volts
Blue	6	1,000,000	±6 %	600 Volts
Violet	7	10,000,000	±7 %	700 Volts
Gray	8	100,000,000	±8 %	800 Volts
White	9	1,000,000,000	±9 %	900 Volts
Gold	—	0.1	±5 %	1000 Volts
Silver	—	0.01	±10 %	2000 Volts
No Color	—	—	±20 %	500 Volts

TABLE 8-6 (Cont'd)

APPLICABLE COLOR CODES
FOR

RADIO RECEIVING EQUIPMENT
RBS-3

ASA TYPE DESIGNATION
AND
COLOR CODE FOR FIXED MICA-DIELECTRIC CAPACITORS

Capacitance Value—The nominal capacitance value in microfarads is indicated by a 3-digit number. The first two digits are the first two digits of the capacitance value. The final digit specifies the number of zeros which follow the first two digits. If more than two significant figures are required, additional digits may be used, the last digit always indicating the number of zeros.

Capacitance Tolerance—The symmetrical capacitance tolerance in per cent is designated by a letter shown below:

TOLERANCE	DESIGNATION LETTER
± 2 per cent	G
± 5 per cent	J
±10 per cent	K
±20 per cent	M

Color Coding—Where marking of type designation is not permitted by space or existing molds, the capacitance, characteristic, and tolerance is indicated by color coding as in Table II.

TABLE II

COLOR	SIGNIFICANT FIGURE	DECIMAL MULTIPLIER	TOLERANCE	CHARACTERISTIC
Black	0	1	± 2 per cent (G)	A
Brown	1	10		B
Red	2	100		C
Orange	3	1,000		D
Yellow	4	10,000		E
Green	5			F
Blue	6			G
Violet	7			
Gray	8			
White	9			
Gold	—	0.1	± 5 per cent (J)	
Silver	—	0.01	±10 per cent (K)	
Black	—		±20 per cent (M)	

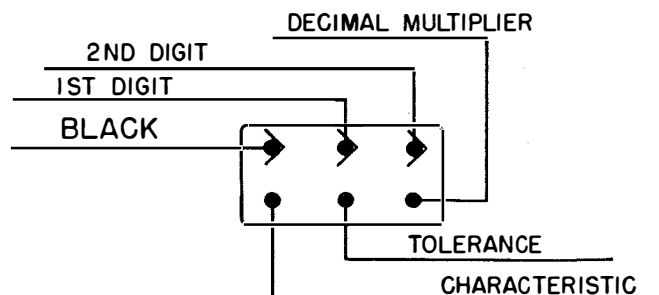

TABLE 8—7. LIST OF MANUFACTURERS FOR
NAVY MODEL RBS-3 RADIO RECEIVING EQUIPMENT

CODE NUMBER	NAME	ADDRESS
1.	Aerovox Corp.	New Bedford, Mass.
2.	Allen-Bradley Co.	1326 S. 2nd Street, Milwaukee, Wis.
3.	Allen Mfg. Co.	133 Sheldon Street, Hartford, Conn.
4.	American Phenolic Corp.	1250 Van Buren Street, Chicago, Ill.
5.	American Radio Hardware	152 MacQuesten Pky., Mt. Vernon, N.Y.
6.	Audio Development Co.	2855 S. 13th Ave., Minneapolis, Minn.
7.	Birtcher Corp.	5087 N. Huntington Dr., Los Angeles, Cal.
8.	Bud Mfg. Co.	2118 E. 55th St., Cleveland, Ohio
9.	Carling Electric, Inc.	505 New Park Ave., W. Hartford, Conn.
10.	Croname	1765 Grace Street, Chicago, Ill.
11.	H. Davies Moulding Co.	1356 N. Wells St., Chicago, Ill.
12.	Dial Light Co. of America	900 Broadway, N.Y. 3, N.Y.
13.	Electrical Reactance Corp.	3444 Elm St., Franklinville, N.Y.
14.	General Electric Co.	Bridgeport, Conn.
15.	International Resistance Co.	401 N. Broad St., Philadelphia, Pa.
16.	Howard B. Jones	1026 S. Homan Ave., Chicago 24, Ill.
17.	Littlefuse, Inc.	4757 N. Ravenswood, Chicago 40, Ill.
18.	Lord Mfg. Co.	Erie, Pa.
19.	P. R. Mallory & Co., Inc.	Indianapolis, Ind.
20.	James Millen Co., Inc.	Malden, Mass.
21.	Moulded Insulation Co.	Philadelphia, Pa.
22.	National Electric Machine Shops	Washington, D.C.
23.	Radio Condenser Co.	Camden, N.J.
24.	R.C.A. Manufacturing Co.	Camden, N.J.
25.	The Sealtron Co.	9701 Reading Rd., Cincinnati, Ohio
26.	The F. W. Sickles Co.	300 Main St., Springfield, Mass.
27.	Sprague Specialties Co.	North Adams, Mass.
28.	Stupakof Ceramic Mfg. Co.	Latrobe, Pa.
29.	Switchcraft	1328-30 N. Halsted St., Chicago 22, Ill.
30.	Wakefield Spring Co.	6542 Cedar Ave., Cleveland, Ohio
31.	Z & W Machine Products	5100 St. Clair Ave., Cleveland 3, Ohio



INDEX

SUBJECT	PAGE NUMBER	FIGURE NUMBER	TABLE NUMBER
A			
Adapter			
Antenna	4—0
Coaxial Cable	4—0
Single Wire	4—0
Alignment			
Beat Frequency Oscillator	7—11
Heterodyne Oscillator	7—11
Intermediate Frequency Amplifier	7—10
Radio Frequency Amplifier	7—11
Setting Up Equipment for	7—10
Amplifier			
Audio	2—9
Intermediate Frequency	2—7	2—10
Push-Pull Audio	2—10	2—14
Radio Frequency	2—3	2—2
Antenna			
Adapter	4—0
Coaxial Lead-In	4—0
Single Wire Lead-In	4—0
Atmospheric Static, Reception With	4—5
Audio Amplifier			
General Information	2—9
Phones Jacks	2—10	2—13
Push-Pull	2—10	2—14
Response of	1—8
Trouble Shooting	7—5
Automatic Gain Control	2—9
B			
Backlash, Frequency or Mechanical	7—15
Beat Frequency Oscillator			
Alignment	7—11
General Information	2—9	2—11
Trouble Shooting	7—9
C			
Cable			
Antenna, Connection for	4—0	3—5
Interconnecting	3—2
Loudspeaker	4—0	3—6
Power, A.C.	4—0	3—7
Characteristics, Electron Tube	7—5
Coils, Winding Data	7-16,7-18,7-20
Color Codes	8—6
Communications, Frequency Range of Receiver	1—1
Controls			
Beat Frequency Oscillator	4—2
Frequency Band	4—2

SUBJECT	PAGE NUMBER	FIGURE NUMBER	TABLE NUMBER
"Gain"	4-1
"Headphone Level"	4-0
Noise Limiter	4-1
"Output Level"	4-1
"Reception"	4-1
"Selectivity"	4-1
Tuning	4-2
Converter, Electronic	2-4	2-2, 2-3
Corrective Maintenance	7-1
D			
Data			
Coil Winding	7-16,7-18,7-20
Electron Tube	7-5
Detector, Electron Tube Diode	2-8
Dial			
Calibration	4-3	4-2
Mechanism of	7-22
Diode			
Automatic Gain Control	2-9	2-6
Detector	2-8
Noise Limiter	2-8
Distortion	2-0
E			
Electrical Constants			
Power Amplifier	7-20
Receiver	7-21
Electron Tubes			
Characteristics	7-5
Included in Equipment	1-2
Replacement of	5-1, 5-2
Emergency Maintenance	5-1
F			
Failure Report Instructions	7-0
Filter,			
Audio	2-12
Power	2-15
Frequency Range of Equipments	1-1
Fuse Failure	5-1	5-2
Fuse Locations	5-1	5-3
G			
"GAIN" Control			
Automatic	4-1
Manual	4-1
General Description of Equipment	1-1
H			
"HEADPHONE LEVEL" control	4-0
Heterodyne Oscillator			
Alignment	7-11
General Information	2-7	2-3, 2-9
Trouble Shooting	7-9

SUBJECT	PAGE NUMBER	FIGURE NUMBER	TABLE NUMBER
I			
Initial Adjustments	4—3
Installation of Equipments	3—1
Interconnecting Cable	3—2
Interference			
Atmospheric	4—5
CW	4—4
Modulated Signal	4—5
Intermediate Frequency Amplifier			
Alignment	7—10
General Information	2—7
Trouble Shooting	7—8
J			
Jacks, Phones	2—10	2—13
L			
Loudspeaker Cable Connections	3—6
Lubrication			
Dial Mechanism	6—4	6—1
Rotating Shafts	6—5
M			
Maintenance			
Check Chart, Routine	6—1
Corrective	7—1
Emergency	5—1
Operator's	5—0
Preventive	6—1
Major Units, List of	8—1
Manufacturers, List of	8—7
Modulated Wave			
Interfering Signal	4—5
Reception of	4—3
N			
Noise Limiter	2—8
O			
Operation of Equipments	4—0
Operator's Maintenance	5—0
Oscillator			
Beat Frequency	2—9
Heterodyne	2—7
P			
Phones Jacks	2—10	2—13
Power Amplifier			
Installation	3—1
Interconnection with Receiver	3—2
Physical Description	1—5
Power Requirements of Equipments	1—1

RBS-3

SUBJECT	PAGE NUMBER	FIGURE NUMBER	TABLE NUMBER
Preventive Maintenance	6—1
Push-Pull Amplifier			
General Information	2—10
Trouble Shooting	7—4
R			
Radio Frequency Amplifier			
Alignment	7—11
General Information	2—3
Trouble Shooting	7—9
Receiver			
Installation	3—1
Interconnection with Power Amplifier	3—2
Physical Description	1—3, 1—5
Reception Control	4—1
Reception, Types of	1—1
Rectifier	1—5
Replacement of Electron Tubes	7—1
Report of Failure	7—0
Resistance Measurements			
Power Amplifier	7—2
Receiver	7—4
S			
“SELECTIVITY” control	4—1
Sensitivity			
Limits	7—12
Testing	7—12	7—5
Shipping Data	1—1
Sockets, Electron Tube			
Diagrams	7—3, 7—4
Relative Locations of	7—20, 7—2
Spare Parts Box			
Shipping Weights and Dimensions	1—1
Static, Reception With	4—5
Stage Gain	7—4	7—1
System Trouble Shooting	7—3	7—2
T			
Tables			
Annual Maintenance Check Chart	6—5
Daily and Weekly Maintenance Check Chart	6—1
Fuse Failure	5—2
Fuse Location	5—3
Monthly Maintenance Check Chart	6—2
Quarterly Maintenance Check Chart	6—3
Resistance Chart for Receiver	7—4
Routine Check Chart	5—1
Semi-Annual Maintenance Check Chart	6—4
Stage Gains Chart	7—1
Test Equipment	6—6
Tube Characteristics	7—5
Voltage Chart for Receiver	7—3
Voltage and Resistance Chart for Power Amplifier	7—2

SUBJECT	PAGE NUMBER	FIGURE NUMBER	TABLE NUMBER
Trouble Shooting			
Audio Amplifier	7—5
Beat Frequency Oscillator	7—9
Chart	7—1
Heterodyne Oscillator	7—9
Intermediate Frequency Amplifier	7—8
Push-Pull Amplifier	7—4
Radio Frequency Amplifier	7—9
Systematic	7—3	7—2
V			
Voltage Measurements			
Power Amplifier	7—2
Radio Receiver	7—3
W			
Weights			
Equipments, Shipping	1—1
Spare Parts Box	1—1
Winding Data for Coils	7-16,7-18,7-20

