

RESTRICTED

BUREAU OF SHIPS
RADIO AND SOUND BULLETIN

No. 17

(NAVSHIPS 900,011.17)



	Page
Removing the mystery from AN nomenclature.....	1
Maintenance stocks of Ordnance-type synchros.....	7
Elimination of interference by directional antennas.....	10
Care and maintenance of relays.....	13
Radio interference elimination.....	20
Arthur O'Brien retires.....	28
The Electronic Field Service Group.....	30
Obsolete solid dielectric cables.....	31
Standard types of dry batteries.....	31
Circuit changes in Carpet (AN/APT-2) and Modified Carpet (AN/UPT-T1) transmitters.....	38
Revised security classification of vacuum tubes.....	42
Use of Link meter with Galvin FM equipment.....	43
Publication News.....	44
The Forum: Cole and Sanders—Connecting American teletypewriter to British teleprinter circuit.....	47
Index to Radio and Sound Bulletins 13 to 16.....	50

JANUARY 1945

REMOVING THE MYSTERY FROM "AN" NOMENCLATURE

The following article was prepared by the Bureau of Ships for C. I. C. magazine. It is reprinted here to permit wider distribution. The AN chart is duplicated on a separate page so that it may be removed for ready reference.

For a long time we have tried to ignore the "AN" nomenclature system on the grounds that it pertained only to airborne equipment and was mainly the Army's worry. But more and more ship and shore gear is appearing with AN numbers, so let's lift the veil of mystery and get the system straight once and for all. We can't play ostrich forever.

The purpose of the system is to make the name tell you as much about the equipment as possible. "A rose by any other name would smell as sweet." That's all right for a rose maybe, but it just doesn't apply to electronic gear. We want a name which tells us at a glance a lot of things, such as where is it used, what kind of equipment it is, and what it is for. That's what the AN system does. So let's see how it works.

The first signal is the opening group of letters—"AN". That means the designating number of the equipment has been assigned jointly by the Army and Navy. It doesn't necessarily mean they both will use the equipment. It does mean that we are concerned with a major equipment and not some component of an equipment. This is parallel to the use of Navy model letters as opposed to Navy type numbers.

The "AN" is followed by a slant line and then come three letters. These letters indicate (1) where used, (2) general type, (3) purpose. Having established the category of the equipment a number is added.



1	2	3	4	5	6
1st Letter, Installation	2nd Letter, Type of Equipment	3rd Letter, Purpose	Model No.	Modification Letter	Miscellaneous Identification
A Airborne (installed & operated in aircraft)	B Pigeon	A Auxiliary assemblies (not complete operating sets)	1	A X	Change in input voltage, phase, or frequency
C Air transportable (designed to be air transportable as stated in specifications or military characteristics)	C Carrier (Wire)	C Communications (receiving & transmitting)	2	B Y	
F Ground, fixed	F Photographic	D Direction Finder	3	C Z	
G Ground, general ground use (includes two or more ground installations)	G Telegraph or Teletype (Wire)	G Gun Directing	4	D	
M Ground, mobile (installed as operating unit in a vehicle which has no function other than transporting the equipment)	M Meteorological	M Maintenance and test assemblies (including tools)	Etc.	Etc.	Experimental Development
P Ground, pack or portable (horse or man)	N Sound	N Navigational aids (including altimeters, beacons, compass & instrument landing)		XA Aircraft Radio Laboratory	
S Shipboard	P Radar	Q Special		XC Camp Coles Signal Laboratory	
T Ground, transportable	R Radio	R Receiving		XE Camp Evans Signal Laboratory	
U General utility (includes two or more general installation classes, airborne, shipboard & ground)	S Special types	S Search and/or detecting		XM Fort Monmouth Signal Laboratory	
V Ground, vehicular (installed in vehicle designed for functions other than carrying radio equipment, etc. such as tanks)	T Telephone (Wire)	T Transmitting		XN Navy	
	R Radio	R Receiving		XO Eatontown Signal Laboratory	
	S Special types	S Search and/or detecting		XT Toms River Signal Laboratory	
	V Visual and Light	W Remote control		T Training Set	
	X Facsimile or Television	X Identification & Recognition		★ Used by Army or Navy and an Allied Government	

This number indicates a specific equipment for the general purpose established by the letters. Let's see how this works on a special case. What is the AN/APS-2? Write it big and use the chart.

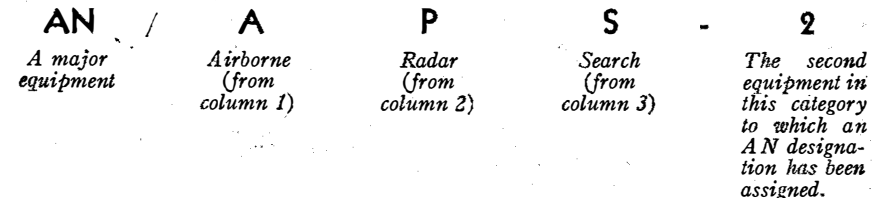

Thus the AN/APS-2 is a radar search equipment used in aircraft. Another equipment in the same category would be the AN/APS-4 or the AN/APS-6. It is very important to note that these numbers do not represent minor design changes in the same series of equipments as you would expect under the Navy model letter system. The RBO-2 is assumed to be an RBO-1 with minor modifications, but an AN/APS-3 may be an entirely different equipment from the AN/APS-2.

How do we distinguish slightly different equipments of the same basic design? Here we pass to column 5 of the chart. If we modify the AN/APS-2 it becomes the AN/APS-2A. The next in the series would be the AN/APS-2B and so on. Now if we keep the same basic design, but merely change the input power of the system as, for example, from 13 volts to 26 volts, then we pass to column 6 and add the letter X for the first change, Y for the second, and so on. Thus the AN/APS-2B becomes the AN/APS-2BX when its operating power is changed.

There are a few more miscellaneous uses for letters tacked on the tail end as shown in column 6 of the chart. An experimental airborne search radar in development at the Naval Research Laboratory might be, for example, the AN/APS-2 (XN). The letter T tacked on the end means a training device for a specific equipment. The first trainer developed for the AN/APS-2A would be the AN/APS-2A-T1.

And that is about all there is to it—except for practice. Try your hand out on the chart using these examples.

What is your AN nomenclature IQ?

- (a) AN/ARC-4X
- (b) AN/ARN-6
- (c) AN/SPT-1
- (d) AN/ARN-T1
- (e) AN/CRT-1A
- (f) AN/APX-1

Answers are printed on page 4.

IDENTIFYING EQUIPMENT COMPONENTS

So far we have talked only of major equipments—the field covered by Navy model letters. Now we will mention briefly the designations for major components of the equipment—the equivalent of Navy type numbers. Components carry indicating letters which tell what type of component it is, a number which identifies the particular component, and finally the AN designation of the equipment of which it is a part.

RESTRICTED

Listed below are the indicating letters and a description of what they stand for.

Component Indicator	Description	Component Indicator	Description
AB	Antenna Base	MT	Mountings
AM	Amplifier	MX	Miscellaneous
AS	Antenna System	O	Oscillator
AT	Antenna	PG	Pigeon articles
BA	Battery, dry	PH	Photographic articles
BB	Battery, storage	PP	Power pack
C	Control Box	PU	Power Units and Motors
CG	Radio frequency cable transmission lines and wave guides with terminals.	R	Radio Receiver
CM	Comparator	RD	Recorder
CN	Compensators, regulators	RE	Relay Assembly
CP	Computer	RF	Radio Frequency Unit
CR	Crystal Units	RG	Radio frequency cables, transmission lines and wave guides.
CU	Coupling Units	RL	Reel Assembly
CV	Converter (electronic)	RT	Receiver & Transmitter
CW	Cover	S	Shelter
CX	Cord	SA	Switching Assembly
CY	Case	SB	Switchboard
DT	Detector (non-electronic) (See CV)	SN	Synchronizer
DY	Dynamotor Unit	T	Radio Transmitter
F	Filters	TA	Telephone Apparatus
G	Generator (See PU)	TD	Timing Device
GO	Goniometer	TH	Telegraph Apparatus
H	Headsets, Handsets, Head & Chest Sets	TK	Tool Kits
ID	Indicator	TN	Tuning Unit
J	Junction, Jack & Terminal Boxes	TS	Test & Measuring Apparatus
KY	Keys, Coders & Interrupters	TT	Teletypewriter & Wire Facsimile Apparatus
LS	Loudspeaker	U	Unions, connectors, plugs, sockets, etc.
M	Microphone	UG	Unions, connectors, plugs, sockets, etc., designed for radio frequencies.
MD	Modulator	V	Vehicles
MK	Maintenance Kit	VS	Visual Signalling Equipment
ML	Meteorological apparatus		

Let's see how this works. What is the RT-22/APX-1? From the above table we find that "RT" denotes "receiver and transmitter." Thus the component we are checking is the transmitter-receiver for an airborne radar I.F.F. equipment. The antenna coupling unit for the same equipment is known as the CU-13/APX-1.

And that's the whole story. A little practice and what seems like a long string of letters and numbers unfolds itself into a pretty complete story of what the equipment is. If all this appeals to you, maybe a rose by some other name would actually smell sweeter. How about renaming the rose "AN/GVW"—a visual type remote control for general ground use. A lot of roses are used that way.

Answers to Quiz on page 3:

- (a) Airborne radio transmitting and receiving equipment. Differs from the AN/ARC-4 in power supply.
- (b) Airborne radio navigation equipment.
- (c) Shipboard radar transmitter.
- (d) Trainer for airborne radio navigation equipment.
- (e) An air transportable radio transmitter—a modified version of the AN/CRT-1.
- (f) Airborne radar I.F.F.

RESTRICTED

1	2	3	4	5	6
1st Letter, Installation	2nd Letter, Type of Equipment	3rd Letter, Purpose	Model No.	Modification Letter	Miscellaneous Identification
A Airborne (installed & operated in aircraft)	B Pigeon	A Auxiliary assemblies (not complete operating sets)	1	A	X
C Air transportable (designed to be air transportable as stated in specifications or military characteristics)	C Carrier (Wire)	C Communications (receiving & transmitting)	2	B	Y
F Ground, fixed	F Photographic	D Direction Finder	3	C	Z
G Ground, general ground use (includes two or more ground installations)	G Telegraph or Teletype (Wire)	G Gun Directing	4	D	XA Aircraft Radio Laboratory
M Ground, mobile (installed as operating unit in a vehicle which has no function other than transporting the equipment)	I Interphone and public address	L Search Light Control			XC Camp Coles Signal Laboratory
P Ground, pack or portable (horse or man)	M Meteorological	M Maintenance and test assemblies (including tools)	Etc.	Etc.	XE Camp Evans Signal Laboratory
S Shipboard	N Sound	N Navigational aids (including altimeters, beacons, compass & instrument landing)			XM Fort Monmouth Signal Laboratory
T Ground, transportable	P Radar	Q Special			XN Navy
U General utility (includes two or more general installation classes, airborne, shipboard & ground)	R Radio	R Receiving			XO Eatontown Signal Laboratory
V Ground, vehicular (installed in vehicle designed for functions other than carrying radio equipment, etc. such as tanks)	S Special types	S Search and/or detecting			XT Toms River Signal Laboratory
	T Telephone (Wire)	T Transmitting			T Training Set
	V Visual and Light	W Remote control			★ Used by Army or Navy and an Allied Government
	X Facsimile or Television	X Identification & Recognition			

Experimental Development

MAINTENANCE STOCKS OF ORDNANCE-TYPE SYNCHROS

The joint circular letter (BuOrd No. F6-44, Buships No. 39, BuAer No. 60-44), dated 17 May 1944, on Maintenance Stocks of Ordnance-type Synchronos is quoted below for information:

Subj: Maintenance Stocks of Ordnance Type Synchronos.

Ref: (a) BuOrd and BuSandA Joint Circular Ltr. (Rest.) of 12 May 1943, BuOrd File S31-3(Mnle), BuSandA File L8/S31 over L4/JJ-2(4).

Encl: (A) List of Ordnance Type Synchronos and Applicable BuOrd Drawing Numbers.

1. The Bureau of Ordnance has cognizance of the procurement of all Ordnance-type synchro units listed in enclosure (A) and any new synchronos that may be developed and procured by the Bureau of Ordnance in accordance with Ordnance Specification 671, including those which are required for installation in instruments and equipments under the cognizance of the Bureau of Ships and the Bureau of Aeronautics. The Bureau of Ships and the Bureau of Aeronautics have cognizance of the procurement and distribution of synchronous units other than Ordnance-type synchronos, which are designed for, or by, the respective Bureaus to meet specific requirements peculiar to the respective Bureaus. Ordnance-type synchronos and applicable Bureau of Ordnance drawing numbers are listed in enclosure (A), for information.
2. Maintenance stocks of spare Ordnance-type synchronos and synchro spare parts required for routine replacement, emergency replacement, and test purposes are currently being supplied to navy yards, naval stations, bases, and forces afloat in quantities commensurate to the total number of Ordnance-type synchronos procured and under procurement for the purpose indicated in paragraph (1) above. Distribution of this stock is being made as follows, and conforms with the policy previously established by reference (a):

A. *Major Source of Reserve Supply:*

- (1) *Material*—Ordnance-type synchronos and synchro spare parts.
 - (a) *Purpose*—Replenishment of stock at primary sources of supply.
 - (b) *Assignment*—Naval Ammunition Depot, Crane, Indiana.

B. Primary Source of Supply:

- (1) Material—Ordnance-type synchros and synchro spare parts.
 - (a) Purpose—Replenishment of stock at navy yards, naval stations, bases and forces afloat.
 - (b) Assignment—Navy Yard, Washington, D. C., and Navy Yard, Mare Island, California.

C. Navy Yards, Naval Stations, Bases and Forces Afloat:

- (1) Material—Ordnance-type synchros and synchro spare parts.
 - (a) Purpose—Routine and emergency replacement of expended or defective synchros and synchro spare parts.

(b) Assignment:

(aa) Navy Yards:

- Navy Yard, Pearl Harbor, T. H.
- Navy Yard, Charleston
- Navy Yard, New York
- Navy Yard, Puget Sound
- Navy Yard, Portsmouth
- Navy Yard, Philadelphia
- Navy Yard, Norfolk
- Navy Yard, Boston
- U. S. Naval Drydocks, Hunter's Point, San Francisco 24, California
- U. S. Naval Drydocks, Terminal Island (San Pedro), California

(bb) Shore Stations:

- U. S. Naval Repair Base, San Diego, California
- Industrial Manager, 15th N. D., Balboa, Canal Zone

(cc) Forces Afloat:

*Major Combatant Vessels (DD's and larger)

- Destroyer Tenders (AD's)
- Repair Ships (AR's)
- Submarine Tenders (AS's)

*-Supplied only complete spare synchros and no spare parts.

3. It is advised that Ordnance synchros of the same Type and Mark are interchangeable regardless of the modification number.

4. Requests for routine replacements of Ordnance-type synchro units and spare parts should be the subject of a requisition, on an approved Supplies and Accounts Form, to one of the primary sources of supply indicated in paragraph 2B above. Emergency requests by letter, dispatch or teletype can be made to the nearest source of supply indicated in paragraphs 2B and 2C above to fill actual emergency replacement requirements.

Enclosure (A)

List of Ordnance-type synchros and applicable Bureau of Ordnance drawing numbers

Unit	Type	Mk. & Mod.	Buord. Dwg. No.	Unit	Type	Mk. & Mod.	Buord. Dwg. No.																																										
Generator	5G	1-0	164360	Motor	5N	5-1A	212774																																										
		1-1	184713			5-2	109419																																										
		1-1A	212818			5-3	172905																																										
		1-2	109659			5-3	172904																																										
		1-3	173105			6-0	164368																																										
		1-3	173104			6-1	184729																																										
		1-4				6-1A	212781																																										
		1-5	300051			6-2	109662																																										
		2-0	164361			6-3																																											
		2-1	184717			6-5	300050																																										
		2-1A	212827			8-0	214972																																										
		2-2	109383			8-1	212871																																										
		2-3	185004			8-2	228604																																										
		2-2A	280348			8-3 R.E.	3890																																										
		2-5	300054			8-3	173150																																										
Generator	7G	3-0	164362	Differential Motor	5D	8-4	264477																																										
		3-1	184725			8-4A	292804																																										
		3-1A	212839			8-2A	265343																																										
		3-2	109385			7-0	164369																																										
		3-2A	228634			7-1	184728																																										
		3-3	173204			7-1A	212811																																										
		3-2B	298368			7-2	109663																																										
		Generator	8G			4-0	164363	Capacitor	3C	7-3	184905																																						
						4-1	184735			7-3	184906																																						
						4-2	109387			7-5	300053																																						
						4-2A	228636			1-0	216891																																						
						4-3	192202			1-1	212798																																						
						Generator	1G			5-1	213036	Capacitor	6C	1-2	265073																																		
										5-0	233879			1-3																																			
										5-2	279675			2-0	216891																																		
Diff. Generator	1DG			1-0	238008					Capacitor	9C			2-1	212932																																		
				1-1	212863									2-2	265073																																		
				4-0	233814									2-3																																			
				4-1	212919									3-0	216891																																		
				4-2	280374									3-1	212934																																		
				Diff. Generator	6DG									5-0	164359	Capacitor	15C	3-2	265073																														
														5-1	184714			3-3																															
		5-2	109384					4-0	216891																																								
		5-3	185114					4-1	212933																																								
		5-3	185105					4-2	265073																																								
		5-2A	280349					4-3																																									
		5-5	300055					Motor	5SDG					-1A	212973																																		
		5-2B	298369			Special Motor	5SN					-1	212983																																				
		Diff. Generator	7DG															6-0	164364	Cont. Transformer	5CTB	-1	164367																										
																		6-1	184734					Special Motor	5SB	-1	212907																						
6-2	109386									-1A	212974																																						
6-2A	228635																	-2	228693																														
6-3	185214																											-2	279966																				
6-2B	298369																													-3	173190																		
Motor	5F																															4-0	164366	Cont. Transformer	1CT	-2	279966												
				4-1	184701											Cont. Transformer	5CT															3-2	113731																
				4-1A	212767																																	Cont. Transformer	6CT	2-2	109759								
				4-2	109661																																					2-2A	280350						
				4-3	173004																																							8-2	109709				
				4-3	173005																																									Special Generator	7SG	8-2	109709
				4-4	233832																																												
				4-5	300052			Cont. Transformer	1CTB					-2	280228																																		
				Motor	5B	5-0	164367					Cont. Transformer	5SB1																																				
		5-1	184709			5CT	1-3													185302																													
																					1-3	185305																											

ELIMINATION OF INTERFERENCE BY DIRECTIONAL ANTENNAS

In a recent "Signal Corps Technical Letter" an article appears on the use of field-constructed directional antennas as a means of eliminating interference in the operation of certain FM equipments. Because these equipments have wide usage in the Naval Service and because the method of approach has considerable practical application, this article is summarized here.

By proper orientation of directional antennas unwanted signals may be eliminated or reduced thus permitting operation under conditions of interference which would be difficult to work through with a whip antenna. The two antennas discussed can be constructed from material readily available in the field, and their dimensions are not so critical as to prevent operation over a practical bandwidth. The whole system can be taken down and erected in a short time. Further they are sufficiently portable to permit trial and error orientation. In other words, the antenna system may be rotated to find optimum operating conditions—and this position may be changed as needed. These antennas are equally effective for directional transmitting or receiving.

Figure 1 shows an antenna planned for use with the SCR 509 and 510. The Army specifies Field Wire W-110-B although any insulated copper wire should operate effectively. The wire is held firmly to the pole by such means as friction tape or pieces of insulated wire. With one man holding each pole the antenna is rotated about the set until the best conditions obtain. It is better to orient the antenna when both interference and the desired signals are being received. After the best position is found, the poles are placed in the ground and held by means of ropes. Wire guys are not recommended.

The pattern in the horizontal plane to be expected in this type of antenna is shown in figure 2. Since the two verticals are one half wave length apart, signals coming from the direction parallel to the plane of the two poles will induce voltages 180 degrees out of phase. But signals from the direction perpendicular to the plane will produce in-phase voltages in the verticals. This accounts for the pattern shown. Actually the half-wave separation is not critical thus permitting the use of a single antenna over a band of frequencies.

In figure 3 we have another type directional antenna readily constructed in the field. It is a vertical half-rhombic and the dimensions shown are for use with the SCR 609 or 610.

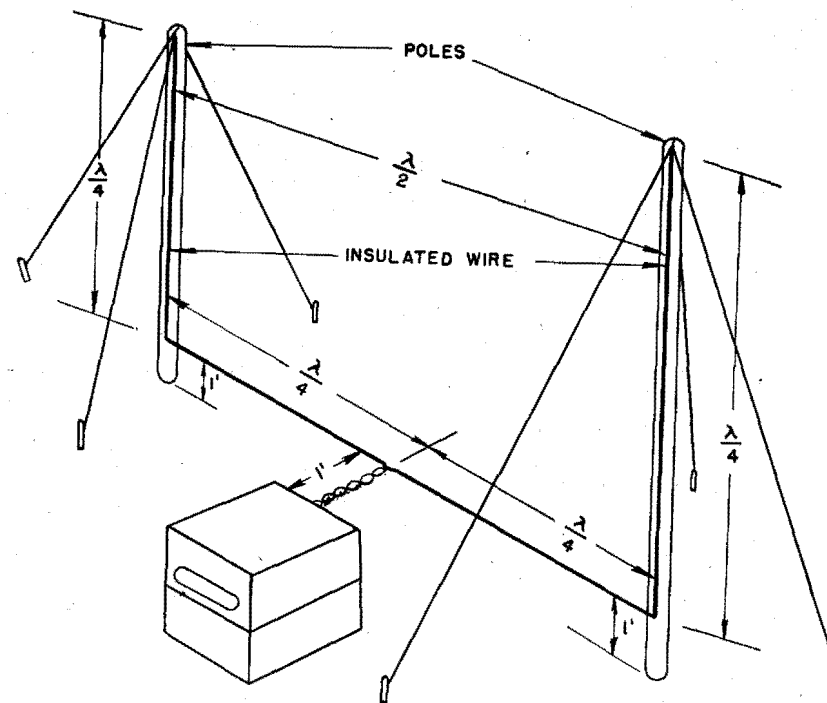

Figure 1.—Directional Antenna for the Model SCR 509 and 510 equipments. This antenna can be erected in the field to overcome conditions of interference.

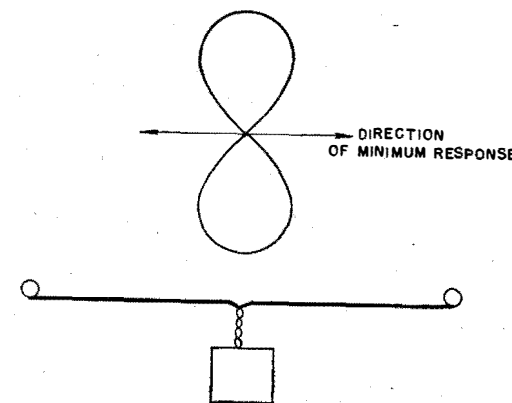

Figure 2.—Field pattern of antenna shown in figure 1. Minimum response is in the direction parallel to the plane of the loop.

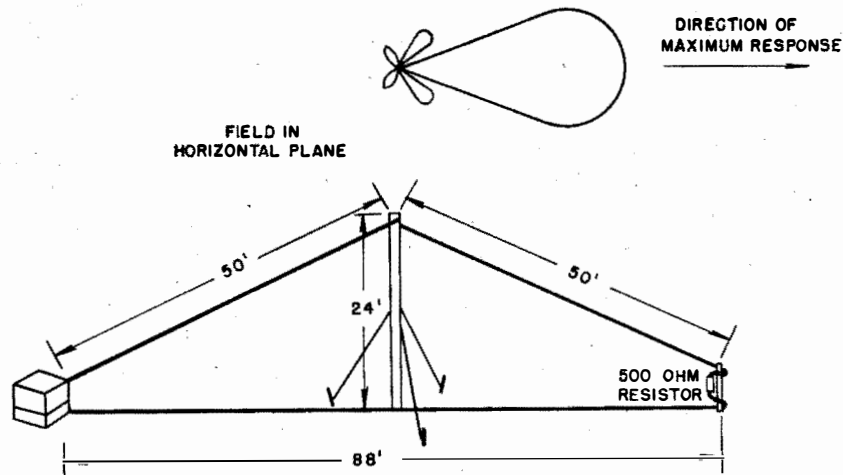

Figure 3.—Another form of directional antenna. The dimensions are for use with the SCR 609 or 610 equipments.

Here again Army Field Wire W-110-B is specified but may be replaced by insulated copper wire. The resistor should be of a non-inductive type between 400 and 700 ohms and rated at two watts or more.

If the direction of the operation is known in advance the antenna is set up with the resistor towards the desired point of communication. However, if the conditions of interference are confused, the best position may be determined by trial. To do this, rotate the stake and pole around the set as a center until the best situation is established. The width of the antenna's field pattern is approximately 40 degrees, so that the placement of the antenna is not critical.

The function of the resistor is to decrease radiation and reception in one direction. By eliminating the resistor the antenna becomes bi-directional. This is of course an important feature since communication in the reverse direction can be set up or eliminated with ease, depending upon conditions of interference.

CARE AND MAINTENANCE OF RELAYS

The number of relays now used in all classes of electronic equipment makes it necessary to give special attention to their care and maintenance. There never was a field in which the "ounce of prevention" was a truer proverb. A great deal of trouble can be avoided if relays are regularly and carefully inspected and if they are properly serviced.

TYPES OF RELAYS

Two major types of relays—adjustable and non-adjustable—are used in radio equipments. Each of these types has a number of subtypes, determined mainly by the application.

Non-adjustable Relays.—A non-adjustable relay has a current coil which drives a contact-carrying armature over a pre-determined distance. This distance cannot be changed; it is fixed by a stop cast into the relay frame at the time of manufacture. In this category the following relays may be classed:

Contactors Relays.—A contactor relay usually is employed to close a power circuit. Its contacts are designed to carry large amounts of current, and its coil has a low d-c resistance.

Interlock Relays.—Interlock relays are used to associate two different components in such a way that one will not operate unless the other is operating.

Sensitive Relays.—Sensitive, permanently sealed relays operate on small amounts of current. The coil used in such relays is wound with very fine wire, has many turns, and consequently has a high d-c resistance. Being hermetically sealed, the relays require no service. If found defective, they must be replaced.

Protective Relays.—Protective relays, are used to short the terminals of high voltage devices such as capacitors, whenever the equipment is shut down. They give maximum protection to the operating and maintenance personnel.

Adjustable Relays.—An adjustable relay has an adjusting screw which controls the distance the armature travels when the current coil is energized. Usually, the moving and the stationary contacts are mounted on leaf springs, and the amount of tension determines the instant of "make" or "break". There are two kinds of adjustable relays:

(a) *Overload Relays.*—Overload relays, operate when the current in the circuit exceeds a pre-determined value.

(b) *Telephone Type Relays.*—This type of relay, is used to close one circuit and open another simultaneously.

INSPECTION OF RELAYS

In general relay trouble will result from two major causes. Where sparking occurs the relay contacts may weld together and thus become inoperative. The other extreme is the creation of high resistance contacts as a result of films forming on the contact surfaces. These films may form from the oxidizing action of air on the metal or from grease. The latter type is most troublesome. In addition, carbon rings will form from the burning of grease films and eventually these rings may build up to the point that the contacts are unable to close.

Another common source of trouble is when the contacts "cone and crater". This results from current flow in one direction through a relay and the resultant removal of metal from one contact (crater) and the depositing of it on the other (cone).

The troubles which these conditions will cause can to a large extent be prevented by regular inspection. When this is done potential difficulties will be noted in time to take corrective action—before the equipment fails.

So inspect relays at regular intervals to detect abnormalities. If the contacts are not readily accessible, they should be examined with the aid of a flashlight and mirror. Many relays can be inspected and cleaned, and have their contacts dressed and cleaned, without being removed from their mounting, or being taken apart.

The mechanical action of the relays should be checked to make certain that the moving and stationary contacts come together in a positive manner and that they are directly in line with each other. The armature or plunger mechanism should move freely, without binding or dragging. Care should be taken during inspection so as not to damage or misalign the relay mechanism.

In general follow these rules. Inspect—

1. The relay assemblies.
2. The connections to the relays and the relay mounting screws.
3. The condition of the contact surfaces. Never open the micro-switches.
4. The operating mechanism and adjustment settings.

TOOLS FOR MAINTENANCE

When inspection discloses that positive action is necessary, the right tools will greatly assist in the maintenance of relays. A few of the most useful tools are described:

The burnishing tool.—One form of burnishing tool consists of a thin hard metal blade about 5 mils thick and $2\frac{1}{4}$ " long fitted with a knurled hard rubber handle. It should be used on telephone type relays which have extremely hard contacts made of palladium or elkonium. A con-

tact should not be burnished unless it is found to be pitted or oxidized and then not any more than is necessary to restore a smooth clean surface. *The burnishing tool must be kept clean.* Otherwise the grease film which it deposits will offset the work performed. Press the contacts together while burnishing them.

Small fine cut files.—Files are used only on large contacts if they become badly burned or pitted and only then if replacement is not available.

Crocus cloth.—This maintenance aid, available in two forms, as a tool and as a strip of material, serves a two-fold purpose. It may be used to remove corrosion from all relay contacts and it may be applied to contacts following the use of the fine file or No. 0000 sandpaper. Neither the file nor sandpaper leaves a finish which is considered smooth enough for proper relay operation. The use of crocus cloth is needed to bring the surface of the contact to a polish. The choice between the stick and the piece of cloth should depend upon accessibility. If the location of the relay and the position of the contacts permit the use of the crocus cloth stick, then it should be used. Otherwise, the strip of crocus cloth must serve. In both cases, the aid is inserted between the contacts and drawn through them while the contacts are gently pressed together with the fingers. The aids also are useful when the relay has been disassembled.

The No. 0000 sandpaper stick.—This tool is made in the same way as the crocus stick except that sandpaper is used instead of crocus cloth. The use of sandpaper is limited, as is the use of the fine cut file, to the treatment of badly burned or pitted contacts on larger relays or contactors. Sandpaper is not used on silver-plated contacts except under extreme circumstances. It should be followed by crocus cloth. All contacts should be wiped, finally, with a clean cloth.

The Cloth aid.—This relay service aid is a narrow piece of folded cloth (or canvas, if cloth is not available). It serves a two-fold purpose. It is suitable for polishing a clean surface, and it is used as a follow-up to crocus cloth. It is intended to remove grains of pumice which come off the crocus cloth and adhere to the contact surface. Use lint-free material.

Chamois stick.—A convenient cleaning and drying tool can be made by mounting a small piece of chamois on a thin strip of bakelite.

CLEANING AND SHAPING

Even though inspection indicates normal relays, periodic cleaning with carbon tetrachloride is recommended. The chamois stick is excellent for this purpose. However, remember that any cleaning fluid but the freshest will normally leave a residue. Therefore, after cleaning always wipe the contact and for this purpose a second dry chamois stick is excellent.

Cleaning relay case.—The relay case should be kept clean by wiping it with a dry or damp cloth. If it is very dirty, clean it with a cloth or brush dipped in carbon tetrachloride. Then wipe the surface with a dry cloth to remove the white deposit left by the solvent when it dries. If loose connections are found, they should be inspected. If inspection shows them to be dirty or corroded, they should be removed and cleaned, and then carefully replaced.

Where it is necessary to remove the relay follow these steps:

Examine the base of the relay to determine the location of the mounting screws. If possible examine the other side of the panel and determine how the screws are fastened in place. Panels, covers, or other parts must often be removed prior to the removal of the relay. *Determine what must be done* before attempting to do it. It will save time and prevent damage to the equipment.

Attach a tag to each relay terminal, with a number or letter on it, and attach a tag to the associated connecting lead with the same number on it.

Remove each lead from the terminal and bend it carefully out of the way. When the leads are reconnected, terminals and leads having corresponding numbers are matched.

Some relays will require disassembly for inspection and maintenance. When this is done, remember the following:

1. Tag and identify all of the leads connected to the relay.
2. Remove all leads connected to the relay.
3. If there is a small micro-switch attached to the relay, remove it.
4. Remove the screws at the base of the coil frame that hold the plunger retaining yoke.
5. Pull the metal yoke away from the frame, lifting it slightly at the same time.
6. The armature, plunger and moving contacts will drop when the yoke is pulled away; so hold the assembly with the hand and move it carefully from the relay. The stationary and moving contacts can easily be removed for inspection and cleaning.
7. The relay is reassembled in the reverse order. Care must be exercised to insure that the connections have been replaced properly, in order to prevent damage to the equipment.

Be extremely careful while working on relays and contactors, so as not to damage the relay mechanisms or to change their adjustment.

Types of relay contacts.—In general, relay contacts are of two varieties—"hard" surface and "soft" surface. Hard surface contacts make use of different kinds of alloys, among which are palladium and elkonium, the material forming the contacts in the telephone type relays. The soft surface contacts are of two kinds. Both are silver, one being solid silver while the other is silver-plated.

Knowledge of the kind of material in the contacts is important. Improper cleaning of the silver-plated relay contacts will soon remove the plating and thus reduce their effectiveness. Study the special techniques described later under "cleaning relay contact".

The care of solid silver contacts also deserves special attention. Although they are not as vulnerable as silver-plated contacts, they are made of soft material and the metal will wear away at an excessive rate if carelessly cleaned.

Telephone relays require a special cleaning technique as described later.

Shapes of relay contacts.—Relay contacts are of various shapes, depending on their size and application. In some instances, both contacts are flat; in others, one contact is convex while the other is flat. The original shape of a contact must be retained during cleaning. If burning or pitting has distorted the contact so that it must be re-shaped, the original shape must be restored. It is essential that the maintenance personnel familiarize itself with all details of the relays by examining them while they are in good condition. In this way, they will be prepared to do their work well.

Whether a relay contact should be left highly polished following cleaning and shaping will depend to a large extent on the application. Where sparking is a problem, a smooth contact will probably be best. However, a rough surface helps to break grease films, so that where films constitute the major source of trouble polished contacts should be avoided.

The following information on cleaning contacts is broken down by various types:

Hard alloy contacts (as in telephone type relays).

(a) *Dirty Contacts.*—Hard alloy contacts are cleaned, when dirty, by drawing a strip of clean wrapping paper between them while holding them together. It may be necessary, in some cases to moisten the paper with carbon tetrachloride. A dry paper or paper strip is used for polishing.

(b) *Corroded, burned or pitted contacts* must be cleaned with the crocus cloth strip or the burnishing tool as described previously.

Solid silver contacts.

(a) *Dirty contacts.*—Dirty solid silver contacts are easily cleaned with a cloth or brush dipped in carbon tetrachloride. After being cleaned, the contacts are polished with a dry cloth.

The brown discoloration that is found on silver and silver-plated relay contacts is silver oxide and is a good conductor. It should be left alone unless the contacts must be cleaned for some other reason. It may be removed, at any time, with a cloth moistened with carbon tetrachloride.

(b) *Corroded contacts.*—Dress the contacts first with crocus cloth, using either the stick or the strip of material. When all of the corrosion has been removed, wipe with a clean cloth moistened with carbon tetrachloride, and polish with a piece of folded lint-free cloth. Make certain that the shape of the contacts has not been altered from the original.

(c) *Burned or pitted contacts.*—Re-surface the contacts, if necessary, with No. 0000 sandpaper, making certain that when the work is done, the shape of the contact has not been changed. Then smooth the surface with crocus cloth. After a high polish has been obtained, wipe thoroughly with a clean lint-free cloth, using carbon tetrachloride when required.

(d) *Very badly burned or pitted contacts.*—If replacements are not available use a small fine cut file or No. 0000 sandpaper as previously described.

Silver plated contacts.

(a) *Dirty contacts.*—Dirty silver-plated contacts are cleaned with a cloth or brush dipped in carbon tetrachloride. After being cleaned, the contacts are polished with a dry lint-free cloth.

(b) *Corroded contacts.*—Dress first with crocus cloth, using either the stick or strip of material. The work must be done very carefully so as not to remove an excessive amount of silver plating. When all of the corrosion has been removed, polish with lint-free cloth. Make certain that the shape of the contacts has not been changed.

(c) *Burned or pitted contacts.*—Dress the contacts with crocus cloth until the burned or pitted spots are removed. This may require an appreciable amount of time, but it is to be preferred to the use of a file or sandpaper. If it is found that crocus cloth does not remove the burns or the pits, then use the sandpaper tool very carefully. If the sandpaper is used, follow with crocus cloth to polish the contact, wipe thoroughly with a cloth moistened with carbon tetrachloride, and dry with a clean lint-free cloth.

Warning: Never use highly abrasive materials such as emery cloth, coarse sandpaper, or carborundum paper for surfacing relay contacts. They will damage the contacts.

ADJUSTMENT OF RELAYS

The adjustable relays in radio equipment are of two kinds—overload relays and switching relays. Each relay has its own method of adjustment. Overload relays are adjusted by varying the amount of current flowing through the coil; switching relays by varying the spacing between the contacts.

Adjusting calibrated overload relays: The following steps should be taken to adjust calibrated overload relays:

1. Remove the glass cover by unscrewing the knurled nut in the center.
2. Examine the bottom of the relay assemblies to locate a cylinder with a beveled and knurled grip. This is the adjusting sleeve. It bears

a horizontal line near its lower end which must be aligned with a point on the scale immediately to the left. The scale is calibrated in amperes. On the left side of the solenoid, there is a small release lever which extends toward the front of the relay. Pressing this lever to the right releases the adjusting sleeve and permits the rotation.

Under all ordinary circumstances, there will be no need for adjustments in the field because the factory settings should never be deliberately altered.

3. Adjust the position of the stationary contacts, if it has been altered. The relay contacts are open when the coil is de-energized. The stationary contacts should be adjusted so that they barely touch the moving contacts when the latter are raised $\frac{1}{32}$ " above their de-energized position.

4. To re-set the indicator (or flag) which shows when the relay has been energized, pull out the knurled stud projecting through the cover nut.

Adjusting telephone relays.—Telephone type relays are adjusted at the factory. It should not be necessary to adjust them in the field. However, if for some reason the adjustment has been lost and a replacement is not available, the following procedure may be applied:

(a) Loosen the screw which passes through the armature and withdraw it until it does not extend past the armature.

(b) Insert a piece of paper (V-mail or notebook) between the core of the coil and the armature.

(c) Press the armature against the paper and turn the screw down until it touches the paper. Draw the screw down tight enough to compress the paper but not hard enough to punch a hole in it. Tighten the lock nut on the screw.

(d) Insert three sheets of paper between the armature and the core, and press the armature down. The breaking contacts should just open.

(e) Remove one of the three pieces of paper and press the armature down against the remaining two pieces. The making contacts should just close.

(f) If the contacts do not close and open properly, the tension of the contact springs must be adjusted until they do. Do not bend the contact springs. Grip the spring near its mounting, with a pair of long-nose pliers. Twist the pliers slightly in the direction that tension is required. Move the pliers along the spring toward the contacts, twisting slightly in three or four places. The result will be a slight bow in the spring.

Repeat the foregoing operations until the contacts open and close properly.

RADIO INTERFERENCE ELIMINATION RADIO NOISE METERS

A radio noise meter is essentially a sensitive portable receiver capable of measuring noise levels and field strength. It may be used as a radio frequency voltmeter to measure voltage between two points, or when equipped with a whip antenna it will measure the strength of a radiated field. It differs from a conventional receiver, however, in several important respects. A time delay is introduced in the A.V.C. circuit so that the output meter will measure the quasi-peak value of the noise since this value is more significant than the average. This circuit is known as the detector weighting circuit. Further, the receiver gain must be adjusted to previously calibrated levels in order that measurements will be uniform for all frequencies. A calibrating signal source is included in the equipment for this purpose. There is also an input attenuator to increase the range of the equipment.

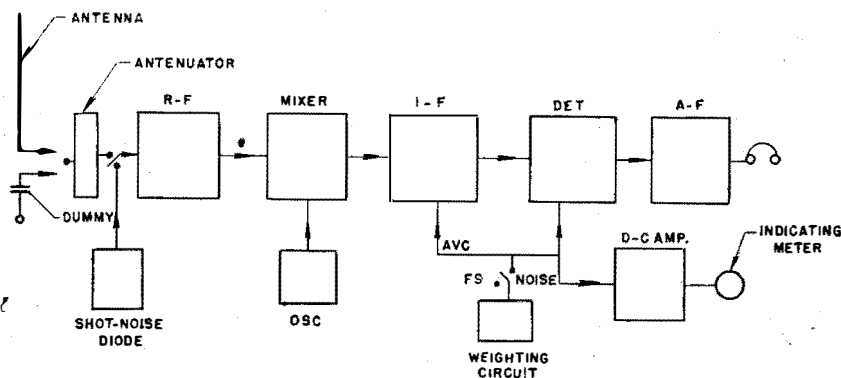

Figure 1.—Block diagram of typical noise meter.

A block diagram of a typical noise meter is shown in figure 1. The single meter shown in this figure serves to measure the battery voltages, adjust the calibrating diode current, set the calibration control, and read the value of the noise or signal intensity.

In an earlier article in this series it was pointed out that noise measurements depended, among other factors, upon the time constant of the integrating circuit (detector weighting circuit), indicating meter

constants, calibrating circuit, type and size of antenna, and receiver bandwidth. These considerations have been standardized by specifications issued by the Joint Coordination Committee on Radio Reception of the Edison Electric Institute, the National Electrical Manufacturers Association and the Radio Manufacturers Association. These specifications apply to equipments covering a range of 150 to 350 kilocycles and 540 kilocycles to 18 megacycles. (The interval between 350 and 540 kc. is provided to accommodate the intermediate frequencies of the meters). The Navy has established parallel specifications and the following significant excerpts are quoted:

(a) The instrument shall have a collapsible vertical rod antenna not exceeding 7 feet in length.

(b) The weighting detector circuit shall have a charge time constant of 10 milliseconds ($\pm 20\%$) and a discharge time constant of 600 milliseconds ($\pm 20\%$). The time constant of the unweighted A.V.C. circuit shall be short compared with that of the weighting circuit.

(c) The indicating meter shall have a damping factor of not less than 10 nor more than 100. It shall have a time constant of not less than 200 milliseconds nor greater than 500 milliseconds.

(d) The receiver bandwidth shall be between 8 and 10 kilocycles.

(e) The self-contained calibrating signal source shall be calibrated in terms of a sine-wave standard, and shall be capable of maintaining the accuracy of the radio noise meter to within $\pm 15\%$ in the frequency range of 540 to 1600 kc. The accuracy at all other frequencies shall be within $\pm 15\%$.

The following equipments have been built around these specifications:

Ferris Model 32A	or	Navy Model OF
Ferris Model 32B	or	Navy Model OF-3
RCA Model 312A	and	RCA Model 312B
Navy Model OF-1 (modified)	and	Navy Model OF-2

It has been pointed out that in order to obtain comparable noise measurements, the receiver gain of the meter must be set at a predetermined level in accordance with the frequency of the noise being measured. A standard noise source is provided for this purpose and is built into the equipment. It consists of a diode (or diode-connected) vacuum tube operating at saturation. The shot noise of the tube when operating at saturation provides a sufficiently constant source of noise for calibration purposes. To maintain the space current at saturation a filament rheostat is provided.

In general, the procedure for calibrating the instrument is as follows: A standard signal generator is connected to the antenna terminal through a dummy antenna equal in capacity to that of the antenna normally used with the equipment. This dummy should be located directly at the antenna terminal. The output of the signal generator is adjusted to supply a given input to the noise meter (e.g. 100 microvolts) and the noise meter is then tuned to the signal generator frequency and

RESTRICTED

its gain adjusted to produce this reading on the indicating instrument. The signal generator is then cut off and the output of the calibrating diode is connected across the first tuned circuit (by means of a switch on the panel—"Cal Pos"). The meter reading now gives the calibration setting for the particular frequency being used. The instrument should be calibrated for a series of frequencies on each band and a calibration curve plotted. To calibrate the instrument with the internal calibrator, it is then only necessary to turn the switch to "Cal Pos", and adjust the gain control until the meter reads the calibration value as determined above. The instructions that accompany each equipment should however be followed in detail. One company produces an "external calibrator" which can be fastened on the noise meter. It is essentially a signal generator covering the same range of frequencies as the noise meter and an output adjustable to 1000 microvolts. It is more accurate than the internal calibrator and not as bulky as a regular signal generator.

In order to provide sufficient gain for calibrating the meter at all frequencies and to obtain correct meter scale over the range of the indicating instrument, it is usually necessary to use specially selected tubes in the r-f and i-f positions. It may also be impossible to obtain correct calibration if the battery voltages are too low. These instruments require extreme care and careful maintenance in order that they shall give reliable service. Realignment and recalibration are necessary at frequent intervals if the equipments are often transported from place to place.

In the frequency range of 15 mc. to 150 mc. there is at present only one suitable equipment available, the Measurements Model 58. This equipment follows the same general pattern as the lower frequency type except that it is arranged for low impedance line input and can be used either with dipole or loop antennas. The bandwidth of the receiver is approximately ten times that of the lower frequency equipments. Since both the bandwidth and type of antenna affect the reading which will be obtained on noise fields measured near the source, it is necessary to use care in interpreting the results obtained. This equipment operates from a built-in combination 115 volt a-c and 6 volt d-c vibrator power supply.

It can be seen that a noise meter is essentially a radio-frequency voltmeter with a special time-constant weighting circuit. It can be used either to measure the voltage between two points, such as across a line, or the voltage developed in an antenna. When used as a two terminal voltmeter, some types of equipments require a dummy antenna placed at and in series with the antenna terminal. This dummy is a condenser having a capacity equal to that of the antenna normally used with the equipment and is necessary in order that the tuning of the first tuned circuit does not change when connecting the instrument across lines. In some equipments the first tuned circuit is not affected

RESTRICTED

and it is possible to calibrate and use the equipment without the dummy for conducted measurements. The instrument requires two calibrations in this case, one with the dummy for antenna measurements and one without the dummy for conducted measurements. The instruction book accompanying each instrument will describe the correct procedure.

If measurements are being made on high-voltage lines, it is also desirable to use series blocking condensers of about 0.01 microfarad capacity between the instrument and the line to keep the line voltage off the instrument. Measurements made on lines are referred to as *conducted measurements* and the noise voltage so measured is called the *conducted voltage* or the radio-influence-voltage (R.I.V.). The term derives from the distinction of voltages on the line due to sources at radio frequencies as opposed to voltages at power frequencies. The value of the voltage thus measured will depend upon the impedance across which the voltage is measured. This varies from a few ohms to several hundred ohms, depending upon the characteristics of the line and the load. In many cases of interference investigation, it is immaterial what the value of this impedance is. However, if measurements are being taken for the purpose of comparing different interference producing equipments that may operate under different load and line characteristics it becomes necessary to specify the conditions of measurement.

Radiation measurements are usually made at a specified distance from the source and with the antenna normally supplied with the outfit. The antennas for the lower frequency equipments are designed to have an effective height of either one meter (79" in length) or one-half meter (41" in length). The reading of the indicating instrument must be divided by the effective height of the antenna used to obtain the field strength in microvolts per meter. The effective height of loop antennas or adjustable dipoles varies with frequency. A table or graph is supplied with these antennas giving the values of effective height for all frequencies within range of the equipment with which they are used. Sometimes these values are converted to multiplying factors to facilitate computation of field strengths.

ELECTROMAGNETIC FIELDS

There are two components of the field set up by a source of interference; one called the electric and the other the magnetic. At distances of several wavelengths or more from the source, the fields are in time phase and space quadrature with each other. They bear a definite relation to each other and either may be used for measurements of the field intensity. They are related by the equation

$$E = 300 H,$$

where E is the electric field intensity measured in volts per centimeter and H is the magnetic field intensity in lines per square centimeter (Gauss). An electric field intensity of 2 millivolts per meter would induce a voltage of 6 millivolts in an antenna of 3 meters effective

height. The antenna is to be oriented for maximum pickup, that is, parallel to the electric lines of force. The direction of the electric lines is referred to as the direction of polarization of the wave.

Since the above relationship for the electric and magnetic fields is considered to hold at distances greater than one wavelength from the radiator, measurements made on the magnetic field by using a loop receiving antenna can be, and usually are, given in volts per meter or some submultiple, such as millivolts or microvolts per meter. Magnetic units are seldom employed in practice.

The relation between the electric and magnetic fields discussed above does not, in general, hold in the immediate vicinity of the radiating source. In this area, measurements made on the electric field may give values larger or smaller than measurements made on the magnetic field, depending on the type and configuration of the radiator. This is an important point because it partially explains discrepancies between measurements made with noise meters using different types of pickup antennas.

Important also is the fact that near the source of the electric field strength decreases inversely with the square of the distance while at distances greater than about one wavelength it decreases inversely with the first power of the distance, neglecting ground attenuation and any reflection of the wave from any of the various possible reflecting surfaces such as hills, buildings or the Heaviside layer.

Because of these differences in the nature of the field at different distances from the source, it is convenient to divide the field into two parts, namely, that part near the radiator which is called the *induction* field, and that part more remote from the radiator which is called the *radiation* field. At distances equal to the wavelength divided by 2π , the two fields are equal. The radiation field is sometimes thought of as the field that leaves the radiator never to return (unless reflected back) while the induction field is the field that stays at home. Either field will induce voltage in antennas. The term "radiated measurement" is used in interference work regardless of how far away from the source the interference is measured.

The amount of interference produced in a certain piece of equipment by any given source will depend upon three factors. They are sometimes referred to as: (a) the influence factor, (b) the coupling factor and (c) the susceptibility factor. The influence factor is determined by the amount of power radiated and the bandwidth or spectrum of the radiation. The coupling factor is governed by the physical separation of the source and receiver, the frequency separation and the nature of the intervening mediums. The susceptibility factor is a function of the type of equipment used in the receiving installation.

Interference usually originates at some point-source, such as motor brushes, vibrating contacts, etc. In order to radiate much power, this source must be more or less efficiently coupled to some radiator such as

connecting wires or the mass of the machine. Point-sources, in themselves, may be troublesome at very close range but they are usually coupled to more efficient radiating mediums. Interference has been known to travel for miles over power lines and may actually be of greater intensity at a point remote from the source than near the source itself. Another important radiator not to be overlooked is any current path formed by multiple grounds. In general, it may be said that the source must be shielded, the connecting lines filtered near the source, and ground loops avoided. More will be said about this later.

When is interference suppression necessary? In general, it may be said that suppression is required on any equipment that is a potential source of interference if there is any possibility of any detectable radiation from that source external to the ship's hull or within the hull in such a manner as to couple to any leads that may in turn couple to some portion of a receiving system. In practice some compromise between cost (and perhaps bulkiness and weight) of the suppression devices and the complete suppression of the interference may be necessary. The question of limits will be discussed later.

GENERAL RULES FOR INTERFERENCE SUPPRESSION

1. *Maintenance of equipment.*—Experience has shown that there is often a definite relation between the mechanical condition of the equipment and the radio noise output resulting therefrom. This is particularly true of rotating and vibrating machinery. All commutators, slip rings, brushes and brush holders must be kept in good condition. All normal ground connections to the frame or housing should be kept clean and tight. Movable contacts such as switch points, relay contacts, etc., should be clean and adjusted for minimum arcing. All shielded connections and bonding must make clean and tight electrical contact. A very frequent source of trouble is that caused by painted contact surfaces instead of clean metal to metal contact.

2. *Shielding and bonding.*—Direct radiation or induction from a source of interference is eliminated by proper shielding and bonding. Naval equipment should be designed and installed with this in mind. Wherever possible, all leads, both power and control, should be run in shielded cable. In some cases double shielded cable is required. All cover plates must fit tightly and make good electrical contact *along the entire edge*. Solid metal is the best form of shield but copper mesh or hardware cloth is effective and can be used where ventilation is required. Bonding between units should be done with large size conductors and the lengths should be kept to a minimum.

The cardinal principle in good shielding is that current shall not be permitted to flow on the outside surface of the shield. If it does, radiation will take place. This principle can best be illustrated by reference to figures 2 in which a load is connected to a high frequency generator by means of a shielded cable. In figure 2 (a), the cable is joined to the

RESTRICTED

two units by suitable coupling units which insure clean and tight electrical contact around the whole periphery of the end of the cable. In this case the high frequency currents are confined to the interior surface of the shielded system as shown by the arrows.

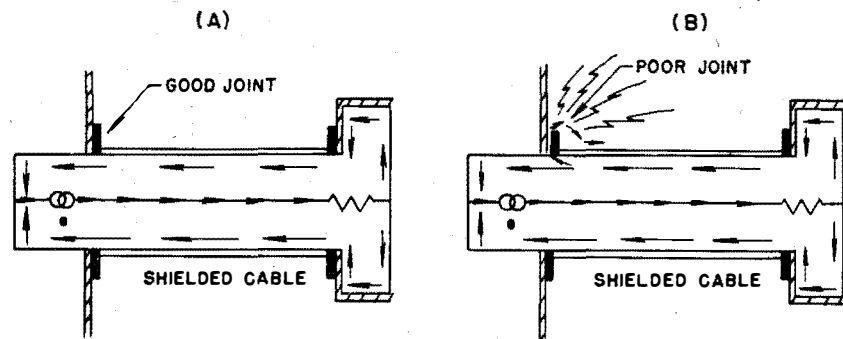

Figure 2.—High frequency generator connected to a load by means of a shielded cable. Drawing (a) shows good joint with current confined entirely to the inner surfaces of the conductor. Drawing (b) shows radiation resulting from poor joint.

In figure 2 (b) a poor joint, possibly caused by a dirty or poorly fitting mating surface, allows current to get out to the exterior surface thereby allowing radiation to occur. This is a practical example that is very frequently found in practice. Numerous cases have occurred where an additional quarter-turn of a coupling nut on an ignition cable has meant the difference between a "quiet" system and one that could not be tolerated. It should be pointed out here that longitudinal breaks in a cable are far less serious than transverse breaks.

3. *Filtering.*—The type of filter to be applied to a source of interference is governed by the type of disturbance, the characteristics of the circuits, the voltage, the current, the power frequency, the amount of attenuation desired, and the frequency range to be suppressed. In all cases, the filter should be mounted as close to the actual source as conditions permit and should be shielded. The output leads of the filter must be kept segregated from the input leads since any capacitive coupling around the filter will destroy its effectiveness. Simple capacitor filters are effective over limited ranges of frequencies if their reactances at these frequencies are low compared with the impedance of the line or device into which the filter is to work. Wide-band attenuation demands that well designed choke-condenser filters be used. In any case, the lead length must be kept short in order to keep the inductance low.

It is not the purpose of these articles to discuss the mathematical design of filters but to indicate the requirements of a good filter from a practical standpoint and to give a few pointers on the proper installation technique. A typical problem is illustrated in figure 3 in which a d-c generator is supplying plate voltage to a receiver through a power cable.

RESTRICTED

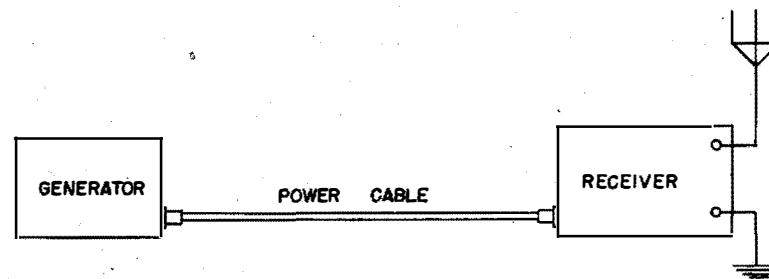

Figure 3.—Typical interference problem requiring filters for solution.

There are three ways by which interference voltage from the commutator of the generator may reach the receiver circuits in such a manner as to produce noise in the output.

- (a) Radiation from the source and lines to the antenna.
- (b) Induction from the "noisy" lines inside of the receiver into the tuned circuits.
- (c) Modulation of the plate currents of the various tubes in the receiver due to the interference voltages of the supply lines.

The effect of (a) may be eliminated by adequate shielding of the source and lines. That of (b) may be eliminated by careful shielding and compartmenting within the receiver. To eliminate (c) requires filtering at the source of the receiver. When filtered at the source, the shielding requirements are somewhat less rigid.

Assuming that the filter is to be applied to the source, it is next necessary to decide upon the type to be used. This will be the subject of another article.

(EDITOR'S NOTE: This is the second of a series of articles on interference elimination.)

ARTHUR O'BRIEN RETIRES

To the "old timers" handling the naval radio circuits between 1912-1916, the sign of "O'B" was synonymous with rhythmic, smooth, and perfect sending which characterized the "man behind the key".

It is, therefore, fitting on the occasion of his retirement that a few of the "old timers" who have enjoyed the pleasure of listening to such harmony by Mr. Arthur O'Brien in those days and who have had the added pleasure of daily association with him since, should endeavor to



Photograph of Mr. O'Brien taken on a recent inspection trip to Pearl Harbor. With him are Captain A. L. Becker, Radio Material Officer at Pearl Harbor, and Mr. Fred Mason, Western Electric engineer.

raise their feeble voices in an inadequate though sincere tribute to his loyalty, devotion and proven ability.

"O'B's" first job was with the Lehigh Valley Railroad. There he served for twelve years as telegraph operator, agent and accountant. In 1912 he enlisted in the Navy, and using his previous training he soon was acting as radio operator and maintenance man. By the time he was discharged four years later he had achieved a rating of RM 1/c.

Shortly after his discharge from the Navy Mr. O'Brien reported to the then Bureau of Steam Engineering as a radio inspector under the Civil Service. At that time, Rear Admiral S. C. Hooper (then Lieutenant Hooper) was officer in charge of the Radio Division. The Radio Division at that time employed only twelve persons. Mr. O'Brien's ability to apply to his new duties that same degree of thoroughness, smoothness, and concentration which gained him recognition as an expert radio man in the Fleet soon earned him the implicit confidence and respect of the officer under whom he served.

Within a year Mr. O'Brien was promoted to fill the vacancy of Expert Radio Aide caused by the resignation of Mr. A. A. Isbell. From the date of assuming these duties until the date of his retirement, Mr. O'Brien was identified with the Shore Radio Station group of the Bureau. He progressed through the various grades of radio engineer reaching that of Principal Radio Engineer in March 1943.

During his years of faithful and devoted service, Mr. O'Brien has been the "guiding hand" in all matters pertaining particularly to installation and maintenance matters for Naval Shore Radio activities. His active handling of such matters affecting the West Coast and Pacific areas and supervision of shore activities elsewhere has contributed much to the Naval communication system in general and to no little extent to the successful prosecution of this war.

A few of Mr. O'Brien's many achievements during his career with the Navy Department are:

- (1) Adjustment of commercial claims for radio stations taken over during the first World War.
- (2) Work in connection with high power low frequency transmitter at radio station Lyons, France, during the first World War.
- (3) Procurement, installation and test of high power, low frequency transmitters at Lualualei and Cavite, and public work items in connection therewith.
- (4) Writing and arrangement of form 25A which gives many details of the conditions and facilities available at all Naval shore radio stations.
- (5) Rewriting and revision of Chapter 31 superseded by Chapter 67, BuShips Manual.

On 26 September 1944 a testimonial farewell dinner was given for Mr. O'Brien. This pleasant affair was attended by a total of fifty persons which included Capt. J. B. Dow, Capt. A. R. Taylor and Comdr. C. L. Engleman. Each of these officers gave voice to the outstanding service, the loyalty, the faithfulness and exemplary character of Mr. O'Brien.

The high regard and esteem in which "O'B" was held by his associates, officers and civilians, was attested to in no uncertain manner by the large gathering which turned out on this occasion to pay their respects.

All hands are sorry to see "O'B" leave. His absence will be felt in many ways, but we are happy to know that he leaves under "his own steam", enjoying the best of health, alert in mind as well as in body.

"O'B" has set a high standard of achievement for all the associates he leaves. He set not only a high standard for others to follow, but one

which he, by precept and example, followed with seeming ease and assurance. Although no marble shaft will be erected as a reminder of "O'B" 's years of conscientious efforts, the splendid work he has done in each task assigned him will serve as a better monument. Truly here's one man who has earned the right to the flag hoist "Well Done". He leaves with our best wishes for continued good health and many years of a happy and well-earned retired life.



THE ELECTRONIC FIELD SERVICE GROUP

The Electronic Field Service Group, an organization of engineers and technicians with special training and practical experience in the field of electronic equipments, has been established to assist RMO's and Fleet Maintenance organizations in site-selection, installation and maintenance of radio, radar, sonar and navigational aids equipments and in the training of field personnel in the maintenance and operation of these equipments.

One of the important services the EFSG offers is assistance in relieving temporary bottlenecks caused by rush projects at RMO activities on the installation and modification of electronic equipments.

The radar section of EFSG has a complement of officers and technicians who are now available for temporary assignment to assist navy yards, naval depots and bases in the complete modernization of search and fire control radar equipments.

Typical problems on which the radar section is ready to offer assistance are the complete shipboard or shore installation of new equipments such as the SR and SM as well as the older types of radar, checkouts of previously installed equipments, testing and checkout of equipments on shakedown cruises, research problems requiring field work, and maintenance work of an emergency nature.

Requests for service should be addressed to Commanding Officer, Electronic Field Service Group (Code 800), Naval Research Laboratory, Washington 20, D. C., with copy to Bureau of Ships (Code 970). Requests should contain the following information: period for which service is required; nature of service; status of installation; number and type of personnel desired; number and type of local personnel available for assignment to the project.

Activities concerned are invited to make immediate and full use of the Electronic Field Service Group.

OBSOLETE SOLID DIELECTRIC CABLES

Until July 1943, all solid dielectric cables employed as dielectric one or another of several compounds which were supplied by the several cable manufacturers. These insulations were the best available at the time and were put into extensive use. The jackets used on these cables were for the most part flexible to -20°C.

By July 1943, American sources of polyethylene insulations were in full production and all new cable production was required to use this new dielectric. Simultaneously, cable designations were changed to the RG/U system, and cable jackets flexible to -40° were made mandatory.

The pre-polyethylene cables are still available in many yards. Since they are at least 1½ years old, and since their electrical loss (attenuation) increases with age, they are no longer desirable for use in circuits carrying radio frequency power or in circuits in which attenuation of any magnitude cannot be tolerated. The present RG/U cables have lower loss, higher dielectric strength, and far superior mechanical and ageing characteristics.

Since the RG/U cables are in adequate supply, it is recommended that all pre-polyethylene coaxial cables not using rubber insulations be segregated and be either marked "for non-radio use" or scrapped.

These cables include CASSF-50-1, CASSF-50-1A, TCSSSF-95-1, TCSSSF-95-1A, CASSF-70-1, CASSF-70-1A. They may be recognized on reels by the reel markings and in coils by the color and hardness of the insulations. The color is white or amber and the material is soft. Polyethylene is grey, translucent, hard, and has a softening point 34-40°F higher than the others. In case of doubt, touch the insulation with a hot soldering iron. The polyethylene melts sharply, but the pre-polyethylene materials become gummy and rubbery.



STANDARD TYPES OF DRY BATTERIES

The following table is a list of present standard types of Army and Navy dry batteries together with commercial equivalents. It should be helpful in eliminating confusion due to numerous designations used. As a further aid to standardization, all Army and Navy types which are equivalent are being labelled with both Army and Navy numbers.

The Army and Navy type batteries may be substituted for commercial types. However, serious difficulty may be encountered if commercial batteries are substituted for Army-Navy types.

TABLE I

Army Type	Navy Type	Dimensions in Inches (See Note "A")				Nominal Voltage	Weight
		Length	Width	Height	Overall Height		
BA-1		1 1/8 ± 1/32 diam.			5 1/8 + 1/8 - 1/16	3.0	10 oz. max.
BA-2	19033	3 1/16 ± 1/16	2 1/8 ± 1/16	2 1/8 ± 1/16		22.5	1 lb max.
BA-8		6 1/16 ± 1/8	4 ± 1/8	3 ± 1/8		22.5	4.5 lb max.
BA-9		2 7/16 ± 1/16	1 3/16 ± 1/16	2 3/16 ± 1/16	3 ± 1/16	4.5	6 oz. max.
BA-15A		2 3/8 ± 1/16	1 3/8 ± 1/16	4 ± 1/16		1.5	14 oz. max.
BA-23	Type A	2 3/8 ± 1/16 diam.		6 ± 1/8		1.5	2 lb 6 oz. max.
BA-26	19004A	8 1/2 ± 1/8	4 3/8 ± 1/8	7 1/4 ± 1/8	7 1/8 max.	45	12.75 lb max
BA-27	19014	4 ± 1/16	1 1/8 ± 1/16	3 1/8 ± 1/16		4.5	1 lb max.
BA-28		1 3/16 ± 1/16	1 1/8 ± 1/16	2 1/4 ± 1/16		4.5	4 oz. max.
BA-30	Type C (19031)	1 1/8 ± 1/32 diam.			2 3/8 + 1/8 - 1/16	1.5	4 oz. max.
BA-31	19013	2 1/16 ± 1/16	1 3/16 ± 1/16	2 1/16 ± 1/16		4.5	6 oz. max.
BA-32	19015	8 + 0 - 1/16	5 + 0 - 1/16	6 1/16 nom.	7 7/16 max.	A 3.0	14.0 lb max.
						B 144.0	
						C -13.5	
						M 4.5	
BA-33		6 1/8 + 1/8 - 1/16	3 1/2 ± 1/16	5 1/8 + 1/8 - 1/16		135	6 lb max.
BA-34	19011	4 1/16 ± 1/16	7/8 ± 1/16	2 13/16 ± 1/16		7.5	10 oz. max.
BA-35	19010	2 3/8 ± 1/16	2 3/8 ± 1/16	3 15/16 ± 1/16		1.5	1 lb 8 oz. max.
BA-36	19005	4 3/16 ± 1/16	2 1/2 ± 1/16	5 7/8 max.		45.0	3 lb 6 oz. max.
BA-37	19037	1 1/16 + 0 - 1/16 diam.		6 nom.	6 1/8 ± 3/16	1.5	10 oz. max.
BA-38	19038	11 1/16 + 0 - 1/16	11 1/16 + 0 - 1/16	11 1/8 nom.	11 23/32 + 0 - 3/32	103.5	1 lb 4 oz. max.
BA-39		6 1/16 ± 1/16	3 3/4 ± 1/16	7 1/8 ± 1/16	7 1/2 ± 1/16	A 7.5	8 lb 12 oz. max.
						B 150.0	
BA-40		5 1/4 ± 1/16	4 3/8 ± 1/16	6 15/16 ± 1/16	7 3/8 ± 1/16	A 1.5	7 lb 12 oz. max.
						B 90	
BA-41		2 3/8 + 0 - 1/8	2 1/8 + 0 - 1/8	3 1/2 + 0 - 1/8	A 4.5 B ¹ 25.5 B ² 60	1 lb max.	
BA-42		1 ± 1/32 diameter		1 15/16 nom.	1 7/8 ± 1/16	1.5	2 oz. max.
BA-43		3 13/16 + 1/16 - 1/8	3 31/32 + 0 - 1/8	7 1/8 + 0 - 1/8	A 1.5 B 90 C 45	5 lb 2 oz. max.	
BA-44		10 3/8 ± 1/8	2 11/16 ± 1/16	6 1/16 ± 1/8		6	10 lb max.
BA-48		10 + 0 - 1/8	2 3/8 + 1/16 - 1/16	4 7/8 + 0 - 1/8	A 1.5 B 90	5.5 lb max.	

Dry battery types

Terminals	Cells Number & Size or Equal (See Note "B")	Commercial Type Designations							
		Bond Electric	Bright Star	Burgess	General Dry	Marathon	National Carbon (Eveready)	Ray-O-Vac	U. S. Elec.
Flat Surface	2 E	321	T2E	322			777	321	
Wire Lead	15 A	1215	15-50W	4156FL	H15A	1540W	763	4151	
Wire Lead	15 D	1512	15-90W	2156FL	H15D			2151	
Flat Springs	3 B	117	03-17	532	H3BF	350	703	531	
Knurled Nuts	F 2	261 Spec	260S	2FBP	H2F		X226	921	
Knurled Nuts	1 No. 6	No. 6	No. 6 Ind		No. 6	No. 6	No. 6 7111	No. 6	No. 6
Spring Clips	30 F	3061 Spec	30-60C		V30F	3090		9303	660
Knurled Nuts	3 D	312 Spec	71-17S	2370	H3D	3201	761T		
Flat Springs	3 A	116	51-17	432	H3AF	340	751	431	
Flat Surface	1 D	102	10M or 10MC	2	D	120 or 2NL	950 or 1050	2LP	995
Knurled Nuts	3 B	317	03-17S	B3SPG	H3B	350ST	781	531R	
	2G3								
	96B				108B6F		X176		
	9B								
	3B								
Insulated Nuts	90A			A90	90A2		X175		
Knurled Nuts	5 B	517	51-03	5540	V5R	5501	773	551	606
Knurled Nuts	F-4		462S	4FH	4FIS	491ST		94-IS	
Knurled Nuts	30 B	3017	30-03BP	5308	V30B	3050ST	762S		623
Flat Surface	1 J				L	L			
Flat Surface	69N			XX69					
Socket	5 F			F5A100	100A5F5		X349		
	100A								
Socket	G 4			4GB60	60B4H		X371		
	60B								
	3 N				60BP		X398		
Socket	17 N								
	45 N								
Flat Surface	1 C	101	11M IND	I	C	110	935	1LP	5
Socket	F 5								
	60 BB						X437		
	30 N								
Insulated Nuts	4 No. 6	5141	146 IND		641	640	1461 141	641	
Socket	CD 6			6TA60	60A6CF			AR-04	
	60 A								

TABLE I

Army Type	Navy Type	Dimensions in Inches (See Note "A")				Nominal Voltage	Weight
		Length	Width	Height	Overall Height		
BA-49		$5\frac{1}{2} \pm \frac{1}{16}$	$1\frac{1}{8} \pm \frac{1}{16}$		$6\frac{1}{2} \pm \frac{1}{16}$	A 1.5	2.5 lb max.
						B ¹ 67.5	
						B ² 67.5	
BA-50		$1\frac{1}{8} \pm \frac{1}{32}$	$\frac{9}{16} \pm \frac{1}{32}$	$2 \pm \frac{1}{16}$	2 $\frac{3}{8}$ nom.	3	1.5 oz. max.
BA-51	19032	$2\frac{1}{16} \pm \frac{3}{32}$	$1\frac{3}{8} \pm \frac{1}{16}$	3 $\frac{1}{16}$ nom.	$3\frac{1}{16} \pm \frac{1}{16}$	67.5	14 oz. max.
BA-53		$3 \pm \frac{1}{16}$	$1\frac{1}{8} \pm \frac{1}{16}$	$4\frac{9}{16} \pm \frac{1}{16}$		45	1 lb 10 oz. max.
BA-56		$2\frac{13}{32} \pm \frac{1}{32}$	$\frac{3}{16} \pm \frac{1}{32}$	3 $\frac{1}{16}$ nom.	$3\frac{11}{16} + 0 - \frac{1}{16}$	45	.10 oz. max.
BA-57		4 $\frac{1}{8}$ max.	1 $\frac{15}{16}$ max.		4 $\frac{9}{16}$ max.	A 1.5	1.5 lb max.
						B 90	
BA-58		$\frac{37}{64}$ max. diam.		1 $\frac{1}{8}$ nom.	$1\frac{15}{16} \pm \frac{1}{32}$	1.5	0.6 oz. max.
BA-59	19021	$3\frac{1}{2} + \frac{3}{32}$	$1\frac{3}{32} \pm \frac{3}{32}$		$5\frac{1}{16} \pm \frac{1}{16}$	45	2 lb max.
BA-63		$2\frac{15}{16} \pm \frac{1}{16}$	$2\frac{1}{4} \pm \frac{1}{16}$		$4\frac{1}{8} \pm \frac{1}{16}$	45	1.5 lb max.
BA-65		$2\frac{3}{8} \pm \frac{1}{16}$	$2\frac{3}{8} \pm \frac{1}{16}$		$4 \pm \frac{1}{16}$	1.5	1.5 lb max.
BA-67	19028	4 $\frac{1}{8}$ max.	1 $\frac{15}{16}$ max.		4 $\frac{9}{16}$ max.	A 3.0	1 lb 9 oz. max.
						B 90	
BA-70		$10\frac{5}{16} \pm \frac{1}{16}$	$4\frac{1}{2} \pm \frac{1}{16}$	$7\frac{3}{4} \pm \frac{1}{8}$	$8\frac{1}{16} \pm \frac{3}{16}$	A 4.5	16 lb max.
						B ¹ 90	
						B ² 60	
BA-80		$10\frac{5}{16} \pm \frac{1}{16}$	$4\frac{1}{2} \pm \frac{1}{16}$	4 $\frac{3}{4}$ max.	5 $\frac{1}{16}$ nom.	A 4.5	10 lb max.
						B ¹ 90	
						B ² 60	
BA-102		$3\frac{1}{8} \pm \frac{1}{16}$	$2\frac{1}{2} \pm \frac{1}{16}$		$2\frac{13}{32} \pm \frac{1}{16}$	22.5	1 lb max.
BA-127		$4 \pm \frac{1}{16}$	$1\frac{1}{8} \pm \frac{1}{16}$	$3\frac{1}{8} + \frac{1}{16}$		4.5	1 lb max.
BA-130		$1\frac{1}{8} \pm \frac{1}{32}$ diameter			$2\frac{3}{8} + \frac{1}{32} - \frac{1}{16}$	1.5	4 oz. max.
BA-138		$1\frac{11}{32} + 0 - \frac{1}{32}$	$1\frac{11}{32} + 0 - \frac{1}{32}$	11 $\frac{3}{8}$ nom.	$11\frac{23}{32} + 0 - \frac{3}{32}$	103.5	1.25 lb max.
BA-139		$6\frac{1}{8} \pm \frac{1}{16}$	$3\frac{3}{4} \pm \frac{1}{16}$	$7\frac{1}{16} \pm \frac{1}{16}$	$7\frac{1}{2} \pm \frac{1}{16}$	A 7.5	8.75 lb max.
						B 150	
BA-140		$5\frac{1}{4} \pm \frac{1}{16}$	$4\frac{3}{8} \pm \frac{1}{16}$	$6\frac{13}{16} \pm \frac{1}{16}$	$7\frac{3}{8} \pm \frac{1}{16}$	A 1.5	7.75 lb max.
						B 90	
BA-200/U		$2\frac{3}{8} \pm \frac{1}{16}$	$2\frac{3}{8} \pm \frac{1}{16}$	$3\frac{3}{8} \pm \frac{1}{16}$	$4\frac{1}{4} \pm \frac{1}{8}$	6	1.5 lb max.
BA-202/UF		$1\frac{3}{8} \pm \frac{1}{32}$ diam.		2 $\frac{1}{4}$ nom.	$2\frac{3}{8} \pm \frac{1}{16}$	1.5	4 oz. max.
BA-203/U	19020	$3\frac{3}{8} \pm \frac{1}{16}$	$2\frac{3}{32} \pm \frac{1}{16}$		$5\frac{1}{2} \pm \frac{1}{16}$	6	3.25 lb max.
BA-204/U		$2\frac{3}{8} \pm \frac{1}{16}$	$1\frac{3}{8} \pm \frac{1}{16}$	4 $\frac{3}{8}$ nom.	$4\frac{3}{8} \pm \frac{1}{16}$	3	14 oz. max.
BA-205/U		$2\frac{3}{8} \pm \frac{1}{16}$	$1\frac{3}{8} \pm \frac{1}{16}$	$3\frac{15}{16} \pm \frac{1}{16}$		3	14 oz. max.
BA-206/U		$7\frac{13}{16} \pm \frac{1}{16}$	$5\frac{1}{4} \pm \frac{1}{16}$	$6\frac{3}{4} \pm \frac{1}{16}$		9	15.5 lb max.
BA-207/U	6F4	$8\frac{1}{2} \pm \frac{1}{16}$	$4 \pm \frac{1}{16}$	$5\frac{3}{8} \pm \frac{1}{16}$		9	9.5 lb max.

Dry battery types—Cont.

Terminals	Cells Number & Size or Equal (See Note "B")	Commercial Type Designations							
		Bond Electric	Bright Star	Burgess	General Dry	Marathon	National Carbon (Eveready)	Ray-O-Vac	U. S. Elec.
Socket	E 2								
	45 N							AB 39716	
	45 N								
Special	2 AA					X91			
Snap-on	45 N			XX45	W45A	467	P4367		
Insulated Nuts	30 AA			Z30N	V-30-AA-2		P7R30N		
Snap-on	30 N			XX30		455			
Socket	R 8			8XW60		X537			
	60 P								
Flat Surface	1 AA	103	59 Ind	Z	AA	170	915	7R	908
Socket	30 BB	6220	30-33	M30			482	P7R30	640
Socket	30 AA			Z30	V30AA		738	P7R30	620
Socket	F 4	4826	462	4F	4F1	491	742	P94A	634
Socket	2 R 4			4X2W60			X538		
	60 P								
Socket	3 G 3								
	60 B				100B15CF	12G100B			
	40 B								
Socket	3 F 3								
	60 A				100A15CF	9F100A			
	40 A								
Wire Lead	15 A	This battery is identical to the BA-2 except that it is specially constructed for low temperature operation							
Knurled Nuts	3 D	This battery is identical to the BA-27 except that it is specially constructed for low temperature operation							
Flat Surface	1 D	This battery is identical to the BA-30 except that it is specially constructed for low temperature operation							
Flat Surface	69 N	This battery is identical to the BA-38 except that it is specially constructed for low temperature operation							
Socket	5 F	This battery is identical to the BA-39 except that it is specially constructed for low temperature operation							
	100 A								
Socket	G 4	This battery is identical to the BA-40 except that it is specially constructed for low temperature operation							
	60 B								
Spring Type	4 F	123	460 HD460	F4H	V4F	490	409 509	941	
Flat Surface	1 D		10P						
Socket	4 F 2	4827	866	2F4	8F4	896	718	P698A	638
Flat Surface Recessed Type	2 F			F2RT			704		
Insulated Nuts	2 F		260BP	F2BP					
Insulated Nuts	6 No. 6	5162	166			662	1662	661B	
Insulated Nuts	6 F 4			4F6H					

TABLE I

Army Type	Navy Type	Dimensions in Inches (See Note "A")				Nominal Voltage	Weight
		Length	Width	Height	Overall Height		
BA-208/U		$1\frac{3}{8} \pm \frac{1}{16}$	$1\frac{1}{8} \pm \frac{1}{16}$	$2\frac{1}{4} \pm \frac{1}{16}$	$2\frac{1}{2} \pm \frac{1}{16}$	3.0	2.5 oz. max.
BA-209/U		1 ± 1/8 diameter		3 3/4 nom.	$3\frac{7}{8} \pm \frac{1}{16}$	3.0	3.5 oz. max.
BA-210/U		$2\frac{1}{16} \pm \frac{1}{16}$	$2\frac{1}{16} \pm \frac{1}{16}$		$4 \pm \frac{1}{16}$	6.0	1.5 lb max.
BA-211/U		$4\frac{1}{16} \pm \frac{1}{16}$	$2\frac{17}{32} \pm \frac{1}{16}$		$2\frac{1}{16} \pm \frac{1}{16}$	22.5	1.75 lb max.
BA-212/U		$15\frac{3}{16} \times$	$4\frac{1}{16}$	$7\frac{1}{16}$	A	1.5	23.5 nom.
					B	90	
BA-213/U		$8\frac{1}{2}$ max.	$4\frac{1}{16}$ max.	$4\frac{1}{8}$ max.	LT	3.0	8.5 lb max.
					HT	162	
BA-214/U		$3\frac{23}{32} \pm \frac{1}{16}$	$1\frac{23}{32} \pm \frac{1}{16}$	$2\frac{13}{32} \pm \frac{1}{16}$		12.0	12 oz. max.
BA-215/U		$6\frac{1}{8}$ max.	$5\frac{3}{16}$ max.		$3\frac{3}{16}$ max.	63.0	4.75 lb max.
BA-216/U	19016	$3\frac{3}{8} \pm \frac{1}{16}$	$3\frac{3}{8} \pm \frac{1}{16}$	$5\frac{3}{8} \pm \frac{1}{16}$	$5\frac{7}{8} \pm \frac{1}{16}$	4.5	4.5 lb max.
BA-217/U	19003	$4\frac{3}{16} \pm \frac{1}{16}$	$2\frac{3}{16} \pm \frac{1}{16}$		$2\frac{3}{4} \pm \frac{1}{16}$	22.5	1.25 lb max.
BA-218/U	19018B	$9\frac{3}{16} + 0 - \frac{1}{16}$	$6\frac{3}{16} + 0 - \frac{1}{16}$	$4\frac{3}{8} + 0 - \frac{1}{16}$	A ¹	3	15 lb max.
					A ²	1.5	
					B	156	
					C	-7.5	
BA-219/U	19006	$4\frac{3}{16} \pm \frac{1}{16}$	$2\frac{3}{16} \pm \frac{1}{16}$	$2\frac{3}{4} \pm \frac{1}{16}$	$3\frac{3}{8} \pm \frac{1}{16}$	22.5	1.25 lb max.
BA-220/U	19045	$8\frac{3}{16} \pm \frac{1}{16}$	$2\frac{3}{16} \pm \frac{1}{16}$	$4\frac{23}{32} \pm \frac{1}{16}$	A	1.5	5 lb max.
					B	90	
BA-221/U	19027	$3\frac{3}{8} \pm \frac{1}{16}$	$1\frac{1}{16} \pm \frac{1}{16}$	$6\frac{1}{2} \pm \frac{1}{16}$	A	1.5	2.25 lb max.
					B ¹	67.5	
					B ²	135	
					C	-6.0	
BA-222/U	19043	$8\frac{3}{16} \pm \frac{1}{16}$	$2\frac{1}{16} \pm \frac{1}{16}$	$5\frac{3}{4} \pm \frac{1}{16}$		6.0	5 lb 6 oz. max.

TABLE II—Index of Navy types and their equivalent Army types

Navy Type	Army Type	Navy Type	Army Type	Navy Type	Army Type	Navy Type	Army Type
Type A	BA-23	19010	BA-35	19020	BA-203/U	19031	BA-30
Type C	BA-30	19011	BA-34	19021	BA-59	19032	BA-51
6F4	BA-207/U	19013	BA-31	19027	BA-221/U	19033	BA-2
19003	BA-217/U	19014	BA-27	19028	BA-67	19037	BA-37
19004A	BA-26	19015	BA-32			19038	BA-38
19005	BA-36	19016	BA-216/U			19043	BA-222/U
19006	BA-219/U	19018B	BA-218/U			19045	BA-220/U

Dry battery types—Cont.

Terminals	Cells Number & Size or Equal (See Note "B")	Commercial Type Designations							U. S. Elec.
		Bond Electric	Bright Star	Burgess	General Dry	Marathon	National Carbon (Eveready)	Ray-O-Vac	
Flat Springs	2 A	115	50-17	422	2A	240	750	421	950
Flat Surface	2 C	110	91-17M	122	C2	210	791 791-A	121	991
Socket	4 F		646	F4P1	4F4	496		P694A	639
Socket	15 B				H15B5		768		
Socket	G 17	0528	61-05	17GD60	60DL-11L		748	AB82	AB666
	60 D								
Socket	2CD3				100 A8CF				
	108A								
Knurled Nuts	8 B				8B				
Spec Socket	42B				42B				
Spring Clips	3F4			4F3H					
Wire Leads	15B		1503W		H15B(3)				
Socket	2F3								
	B15				105B9G				
	104B								
	5B								
Spring Clips	15B	1519		5156SC	H15B	1550SC	778-1		
	CD4								
Socket	60B			4TA60					
	AA6								
Socket	Tapped from B2			8MXX 90M4		X444			
	90N								
	4AA								
Insulated Nuts	4F4			4F4H					

Note "A": All dimensions shown without tolerances are either maximum or nominal as indicated.

Note "B": In the column "Cells, Number & Size", Bureau of Standards cell size designations are used. The number preceding the letter shows the number of 1.5 volt units connected in series. The number following the letter shows the number of cells connected in parallel in each 1.5 volt unit. Where no number is shown, unity is understood. Examples: "3D" indicates 3 size D cells connected in series to give a 4.5 volt battery; "F4" indicates 4 size F cells connected in parallel to give a 1.5 volt battery; "3F4" indicates a total of 12 size F cells with 3 units connected in series to give 4.5 volts, each unit containing 4 size F cells connected in parallel.

CIRCUIT CHANGES IN CARPET (AN/APT-2) AND MODIFIED CARPET (AN/UPT-T1) TRANSMITTERS

Considerable difficulty has been experienced in tuning Carpet Transmitters between 520 and 560 megacycles. This difficulty has been characterized by frequency jumps, critical antenna adjustment, unbalanced oscillator tube plate currents, and generally low power output through this range. This article describes circuit changes developed by Radio Research Laboratory, Harvard University, which eliminate these difficulties to a large extent.

The trouble is due, at least in part, to the fact that when the plate and grid line shorting bars are at the approximate electrical center of the oscillator circuit there are two possible modes of oscillation. One of these modes is push-pull (the desired condition), and the other is a parallel condition of oscillation.

When the set is oscillating as a push-pull system, the part of the lines back of the shorting bars should be relatively free of r.f. potential. However, when the parallel condition prevails, the whole of the grid and plate lines becomes an important part of the oscillatory circuit and the point of maximum r.f. potential is at the fixed shorting bar on the back of the lines. The shift from one oscillatory system to the other is usually accompanied by a slight shift in frequency and a change in power output due to a change in optimum coupling position. Under certain conditions of tuning, the oscillator will shift rapidly from one mode to the other, giving the appearance of two oscillator frequencies and other phenomena normally associated with quenching.

It would seem then that a logical remedy would be to maintain the back ends of the oscillator lines at ground potential and thus eliminate the parallel oscillation. Unfortunately, at the higher frequencies, the lines back of the shorting bars, in the Carpet oscillator, are necessary in order to provide proper excitation for the grid circuit to maintain push-pull oscillation. It has been found that if the end of the lines are maintained at r.f. ground potential, the circuit will not oscillate at the higher frequencies. The remedy actually adopted represents a compromise. Condensers are connected to the back of the lines to reduce the r.f. potential but still offer enough impedance to allow the transmitter to oscillate satisfactorily at the higher frequencies.

Another possible system of oscillation is for the entire lines to operate as quarter wave lines in a system of parallel oscillation. On Carpet trans-

mitters this operation would give a frequency of 400 mc. substantially independent of the position of the shorting bars. Tying condensers from the back of the lines to ground has a tendency to increase the likelihood of oscillation in this mode. Therefore considerable care must be undertaken to use the proper valued condenser and in its manner of installation. With the values and the manner of installation herein given no trouble has yet been encountered in any of the sets thus far converted.

MODIFICATION INSTRUCTIONS

1. Connect a 10 micromicrofarad Erie Ceramicon Type N750K condenser from the dead end of each plate and grid line to ground in the manner shown in figures 1 and 2. Four (4) condensers are required for each transmitter. It is important that only 10 micromicrofarad Erie Ceramicon Type N750K condensers be used. Capacities greater or less than this value are likely to cause improper operation as explained in the paragraph above. There are no substitutes. The condensers must be connected exactly as shown in figures 1 and 2. The condensers must

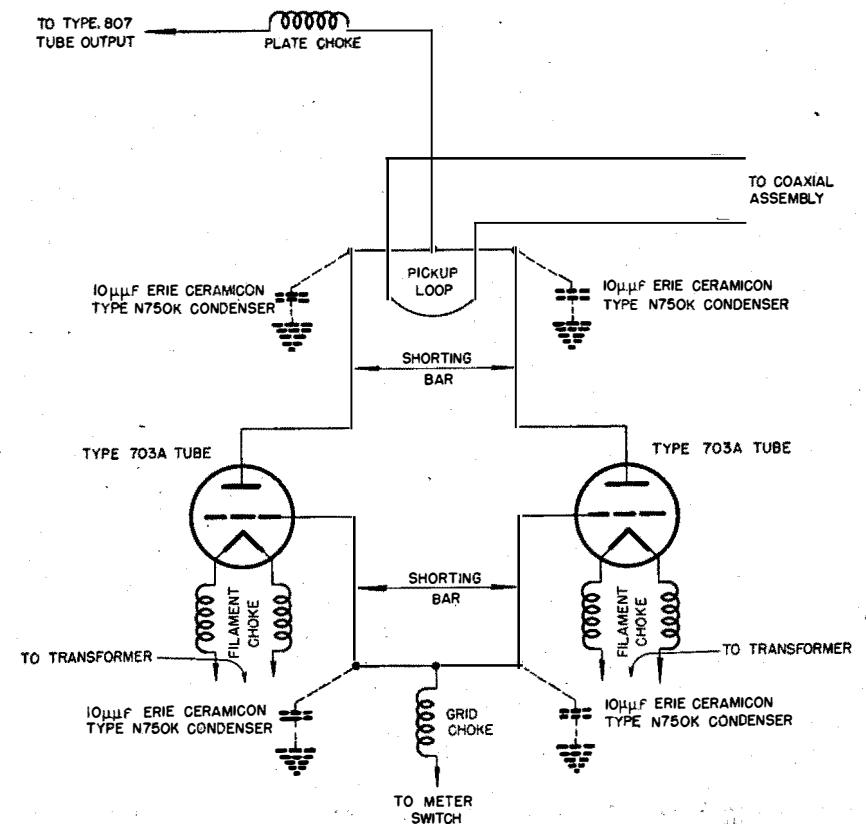

Figure 1.—Schematic diagram of modified oscillator. Four added condensers shown in dotted lines.

be on the tube side of the fixed short and bakelite block rather than back of the block.

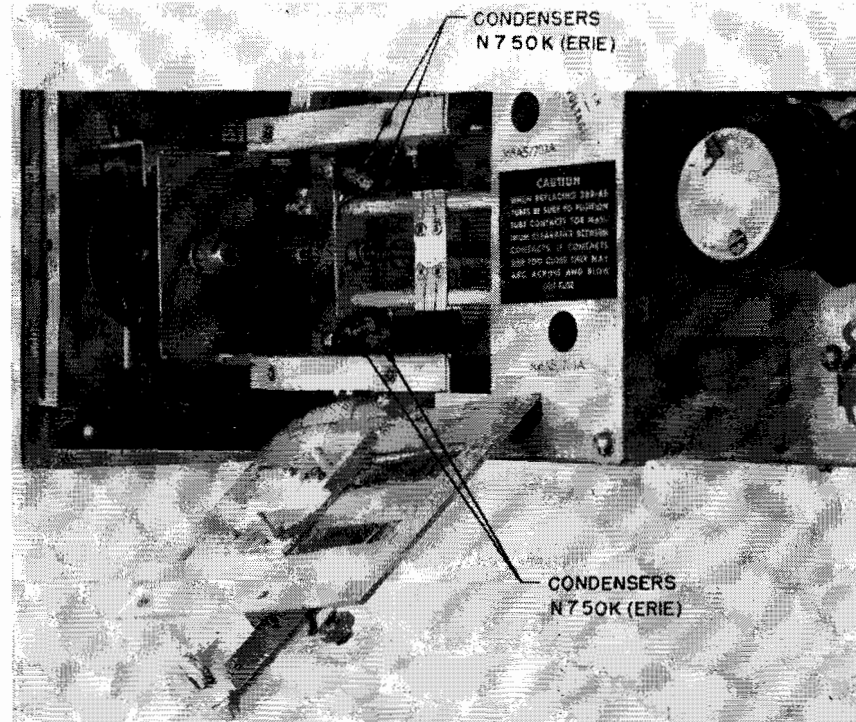

Figure 2.—Photograph of oscillator section showing ceramic condensers installed

2. Frequency skips and greatly unbalanced oscillator tube plate currents are eliminated in the modified sets. The output drop in the 520 to 560 mc. portion of the frequency is almost entirely eliminated, giving a relatively high level output performance over the normal range of Carpet transmitters. In all cases tried, the overall output is higher over the specified range of Carpet transmitters.

3. The 10 micromicrofarad Erie Ceramicon Type N750K condenser has the Navy Type Number CER-481692. It is available from Naval Supply Depots.

4. Figure 3 is a set of curves which gives a typical example of the advantages possible when modification is made in accordance with instructions given here-in. It will be noted that the big dip in performance in the range 520-600 mc. is much improved. Also, there is a general increase in power through-out the frequency range.

5. The advantages brought about by this circuit change indicate the desirability of modifying all Carpet (AN/APT-2) and Modified Carpet (AN/UPT-T1) Transmitters immediately.

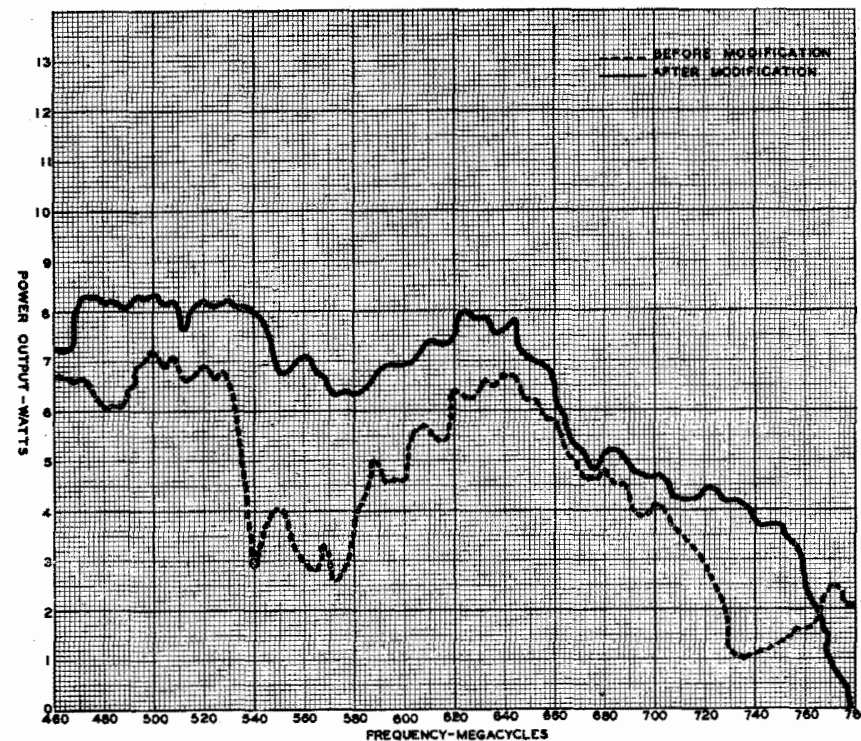

Figure 3.—Graph of power as a function of frequency before and after modification showing typical improvement.

PUBLICATION NEWS



NEW BOOKS OUT

In Radio and Sound Bulletin No. 16 a list of Bureau publications was printed. Some additions to this list have since come out.

Catalogue of Naval Radio Equipment.—Confidential—SHIPS 275 (RPS). This is a new edition and replaces the two earlier volumes, ENG 175 and SHIPS 207. Holders of these catalogues should replace them with the new edition. 228 pages.

Advance Base Teletype Installation and Maintenance Practices.—Not Classified—Navships 900,031. This pamphlet contains much valuable practical information on the installation, care, and operation of teletypewriter systems. 68 pages.

Servo-Synchro Block Diagrams for Shipboard Radar Equipments.—Confidential—Navships 900,048. Servo-synchro systems of shipboard radars are presented as block diagrams. Distributed to maintenance activities, repair ships, tenders, and schools. 114 pages.

Photographs of Shipboard RCM Equipment.—Confidential—Navships 900,054. Contains photographs of production models of RCM equipment. Provides information on weight and dimensions of the equipment. Distributed only to installing activities. 40 pages.

Instructions for Operation of SA2-PPI Radar.—Confidential—Navships 900,041. Another in the series of operational pamphlets. Distributed to all SA-2 equipped ships. 80 pages.

RECENT INSTRUCTION BOOK DISTRIBUTIONS

Instruction books are now becoming available in sufficiently large quantities to place stocks in the hands of Radio Material Officers. Those books listed in the following table have been distributed recently. *With the exception of books having short titles starting with SHIPS, they may be obtained from the nearest RMO. Books carrying SHIPS titles are available through Registered Publications Issuing Offices. Look particularly for finals books on equipments you have aboard, and replace your preliminary editions.*

Model	Short Title	Edition ¹
ABK Suppressor Kit	Navships 900,243-IB	F
AN/UPT-T1	Ships 256	F
BO-1	Ships 253	P
BO-1 (Installation)	Navships 900,239-IB	P
CAOD-10345 Vector Computer	Navships 900,476-IB	F
CC-211133 MG Set	Navships 900,475-IB	F
CG-21ABP Step x Step Converter	Navships 900,265-IB	F
CHC-60ACU	Navships 900,465-IB	F
CNR-23442 Transmitter Control and Keying Unit	Navships 900,343-IB	F
CRV-29248 BDI Adapter/CRV-53191 Filter Junction Box	Navships 900,372-IB	P
CRV-55149 BDI	Navships 900,371-IB	P
CTU-62153 Voltage Divider Probe	Navships 900,396-IB	F
CW-49499/49500 Wave Guide Adapters	Navships 900,283-IB	F
CW-49507A Headset Assembly/CW-51071 Microphone Assembly/CW-10327 Gas Mask Adapter		F
DAS-3	Navships 900,254-IB	P
Gaston 443 MG Set		F
JP-2		P
JP-3		P
LO-3	Navships 900,285-IB	F
MAN		F
Mark 8, Mod 2	Ships 265	F
NK-5	Navships 900,219-IB	P
OAA-2	Ships 227	F
QCU	Navships 900,299-IB	P
QGB Maintenance	Navships 900,341-IB	P
QGB Operation	Navships 900,267-IB	P
QJB	Navships 900,238-IB	F
Range Recorder Kits for QJA and QBF		F
RBM/1/2/3		P
RCK	Navships 900,228	F
SJ-1	Ships 258	F
SLa	Ships 255	F
SO-3	Ships 260	P
TAB-7		P
TBA-8	Navships 900,290-IB	F
TBL-10		P
TBL-11		P
TBL-12		P
TBS-7		P
TBW-4		P
TCS-6	Navships 900,269-IB	F
TS-15A/AP	CO-AN-35TS15-2	F
TVG for QCL-7, QCJ-8		F
UE-1	Navships 900,427-IB	P
YE-1 Antenna		F
YG-1/YG-2	Navships 900,252-IB	F

¹ "F" equals "Final"; "P" equals "Preliminary"

SONAR BULLETIN GOES LOOSE-LEAF

The fifth edition of the Sonar Bulletin will be out soon—estimated about 15 January. It will be loose leaf and contained in a binder similar to the CEMB and RMB. Monthly supplements of about thirty-two pages each will be published to keep it up to date. All new material in these supplements will be set off with arrows. The purpose of this is to enable you to find the new items quickly among the other material, some of which will be reprinted articles. We suggest that these supplements be passed about when received to interested individuals, so that they can learn what's new. Then file the supplement in the binder according to directions.

DISTRIBUTION OF CONFIDENTIAL INSTRUCTION BOOKS THROUGH THE REGISTERED PUBLICATION SYSTEM

The Bureau of Ships uses the facilities of the Registered Publications System to distribute most of its confidential instruction books on electronic equipment. None of these books, however, is registered, and no accounting is required.

Equipments are always shipped with the preliminary instruction books placed in the crate containing the main unit. The Report of Material Shipped will indicate the package in which the books will be found. However, final instruction books will not usually be available until after the equipments have been delivered. These books are then made available through the Registered Publications Issuing Offices. No authorization from the Bureau of Ships is required to draw these books when they are for use by a command having the equipment. The same rule would hold for preliminary books should they become damaged, worn out, or missing from the equipment.

In order to make sure that they have the latest edition of confidential instruction books on board, ships should check with the RPIO's after arrival and prior to departure from yards or bases. Other books are distributed through RMO's, and their offices should be visited in the same manner.

DISPOSITION OF REPLACED INSTRUCTION BOOKS

As soon as preliminary instruction books are replaced by the final edition, they become obsolete and should be destroyed in order to eliminate needless storage. However, activities having a definite use for the superseded books, may retain them at their own discretion.

Confidential publications must be destroyed by burning. Restricted books may be torn, shredded, or reduced by any convenient means to illegible form.

THE FORUM



THE FORUM is a means of exchanging views on an informal basis. In this column new ideas, personal opinions, and comments are always welcome. Send them via your commanding officer to The Editor, Radio and Sound Bulletin, Bureau of Ships (Code 993), Navy Department, Washington, D. C.

GRIPES AND PRAISE

We recently received a letter from a CRM which we print below. We like this kind of letter, because it lets us know what's good and bad. Here in the Bureau we are doing our best to put out the type of information which will be most useful to the fleet in the installation, maintenance, and operation of its electronic gear. Some of the information is very specific, other is more general in nature and designed to give the man with a little spare time a broader background in his work. But whatever it is, we like to know whether it is ringing the bell. So don't hesitate to send in your gripes—and naturally we aren't adverse to a few kind words if you mean them.

The Editor
Communications Equipment Maintenance Bulletin.
Dear Sir:

I am writing to you to register a few personal gripes, as well as to hand out a few compliments, concerning your CEMB (NAVSHIPS 900,020).

To begin with, in the line of gripes, we don't seem to be getting all these bulletins and changes. The most recent one I've received is the one of 15 August, 1944. It is CEMB No. 11. CEMB No. 9 and CEMB No. 10 have to date failed

to put in their appearance. Whether the fault lies with the Postal Service or some where else, we don't have them and we'd very much like to be able to have the information they contain.

The second gripe I have to get off my chest is this. Whoever punched the pages of CEMB No. 11 made a slight mis-calculation. The holes are spaced differently from all previous bulletins, and they are punched in such a manner that it isn't possible to re-punch them so they will fit the binder neatly. A bit more care on lining up the holes will help a lot, and will save a lot of profanity, I'm sure!

As for the compliments—I believe that this CEMB idea is one of the best I've run into in 18 years of Naval service; it is something that we have been needing for many years, and I'm glad to see it has come to be. I have obtained a lot of help and good information from it and so have the men working with me. Whoever is responsible for the idea deserves a lot of praise and credit. I route this bulletin around to all the men connected with material and maintenance and I know they too have obtained a lot of good from reading it. I hope to see the CEMB continue to thrive and prosper.

Since the points raised in this letter are probably pertinent to several thousand other activities, we'll answer them here:

Paragraph 1.—The mailing of these publications is subject to all the hazards of mishandling and wrong delivery that go with long-distance mail communication. However, before you write us that issue so-and-so is missing, check your ship or station carefully. Someone may have popped it into a safe to be read at his leisure—which never quite arrived. This and all other publications should be passed around for a quick look and then left permanently in a place where every one concerned can get at them readily.

Paragraph 2.—We'd like to have a record of all the profanity which this punching error caused. However, the printer's mistake was not discovered till the copies had all been mailed. We hope it won't happen again.

Paragraph 3.—The business about routing the bulletin to all the material and maintenance men is great. Note comments under paragraph 1.



CONNECTING AMERICAN TELETYPEWRITER TO BRITISH TELEPRINTER CIRCUIT

J. F. COLE, RT/1c, USNR and E. P. SANDERS, RT/1c USNR
U.S.S. Ancon

British teletypewriter nets employ polarized method of signal transmission. In order to permit the model M15 and M19 teletypewriters to send and receive polar signals, Radio Technicians first class J. F. Cole and E. P. Sanders of the U. S.S. Ancon have constructed an adapter which can be built in the field from readily available parts. Laboratory tests of the circuit showed it to be of sound design. However a few minor modifications were made to improve operation. A schematic drawing of the adapter is shown as figure 1.

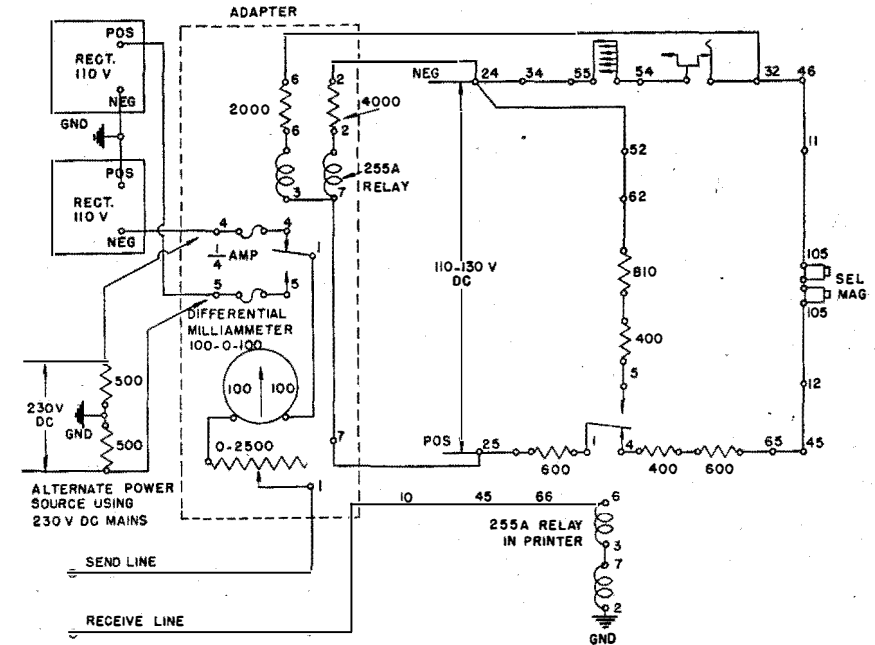

Figure 1.—Adapter to permit operation of American teletypewriter with British teleprinter circuits.

In order to connect American teletypewriters to British teleprinter circuits the following basic provisions must be made:

- A device for the exchange of two-path polar signals and neutral signals must be provided. This is accomplished by the adapter.
- The motor speed of the American teletypewriter must be increased to 2308 r.p.m. Check with the No. 104984 Tuning Fork (96.19 v.p.s.) or a tachometer.
- Adjust sending line current to a value between 2 and 10 milliamperes and receiving line current to a value between 10 and 30 milliamperes.
- Adjust the Right Margin Screw to allow a carriage-travel of 70 characters and adjust signal bell to operate on the sixty-fourth character.
- The unshift-on-space feature present in some machines must be made inoperable.

When using the adapter shown in figure 1 the following wiring changes must be made:

- Interchange power leads from terminals 24 to 25 and 25 to 24 in Teletypewriter.
- Connect send line to No. 1 terminal of adapter.
- Connect receive line to No. 10 terminal in XRT-115 Table.
- Remove wire from No. 7 punching of 255-A relay in Printer and tape.
- Remove wire from No. 3 punching of 255-A relay in Printer and tape.
- Strap No. 7 and No. 3 punchings of 255-A relay in Printer.
- Remove wire from No. 2 punching of 255-A relay and tape.
- Connect ground to No. 2 punching of 255-A relay.
- Strap No. 34 terminal to No. 24 terminal in Printer.
- Connect wire from No. 6 terminal of adapter to No. 32 terminal in Printer.
- Connect No. 7 terminal of adapter to No. 25 terminal in Printer.
- Strap No. 3 and No. 7 terminals in adapter.
- Remove yellow wire from 46 going to 62 and tape.
- Strap 32 and 46.

RESTRICTED

The foregoing wiring changes are correct only for the model 15 typewriter with associated XRT-115 table. However, the modification can be made by similar changes to the model M19.

It should be pointed out that the adapter is for emergency use only, for there is inherent bias present which will result in unsatisfactory operation under certain line conditions. Where permanent interoperation is contemplated, a standard polar-neutral adapter should be provided, such as Repeater Set TC18 (Terminal).



INDEX TO RADIO AND SOUND BULLETINS NOS. 13 TO 16

	<i>Bulletin</i>	
	<i>No.</i>	<i>Page</i>
ANESA.....	14	4
AN/FGC-1A Keyer, replacement of coaxial cables and connectors.....	15	27
Antennas, recommendation for low frequency transmitting.....	15	29
BC-639A, modification of.....	14	43
Boehme high-speed keying heads and ink recorders, care and adjustment of.....	14	36
Catalogue of Naval Radio Equipment.....	13	39
Connectors for radio frequency cable, standardization of.....	13	16
Copper oxide rectifier.....	13	1
Direction finder receivers, radiation from.....	15	41
Failure report form, revised.....	15	25
FM equipment, maintenance notes on.....	15	43
FM equipments, correction to article on.....	16	26
Haslett, retirement of.....	13	37
Instruction books, distribution of.....	13	8
Instruction books, distribution of final.....	14	20
Instruction books, field distribution of.....	16	27
Ink recorders and keying heads, care and adjustment of.....	14	36
Joint Army-Navy specifications for radio and radar components.....	16	21
Keying heads and ink recorders, care and adjustment of.....	14	36
LD-4 temperature control circuits.....	14	45
Low frequency transmitting antennas, recommendation for.....	15	29
MAA and MZ equipments, prevention of ammeter burn-out.....	13	47
Modulator-Adaptor, Type RF-9/UPT, correction to preliminary instruction book.....	16	25
MZ and MAA equipments, prevention of ammeter burn-out.....	13	47
Noise and interference, design requirements for elimination in aircraft communication equipment.....	14	10
Noise, effect of on intelligibility on radio reception.....	13	38
Noise limiters, effectiveness of type CBK-50142.....	15	27
"Notes on Servicing" and "Sound Material Handbook", distribution of OF-1 equipment, field modification of.....	14	20
OF-1 equipment, field modification of.....	16	17
OQ series vacuum tube testing equipment, test data for.....	14	21
OZ tube analyzer, additional tube test data for.....	16	14
Publications, availability of confidential.....	13	27
Publications, electronic of Bureau of Ships.....	16	9
Radio Division, history of.....	15	1
Radio Division, organization chart of.....	13	28
Radio frequency cables, list of Army-Navy.....	13	11
Radio frequency cables, standardization of connectors for.....	13	16
Radio instruction panel.....	16	28
Radio interference, elimination of.....	16	1
RAS series receivers, broadening selectivity of.....	14	7
RCK receiving equipment, description of.....	14	3
Report, revised failure form.....	15	25

RESTRICTED

	<i>Bulletin</i>	
	<i>No.</i>	<i>Page</i>
Requisitions for Class 16 replacement.....	15	28
R.F. cables, instructions for assembling connectors to.....	13	21
SCR-399, reinforcement to prevent damage in shipment.....	13	40
SCR-573-A and SCR-574-A equipments, description of.....	13	29
Soldering, note on.....	15	48
Sonar, use of term.....	13	27
"Sound Material Handbook" and "Notes on Servicing", distribution of Standard frequency broadcast service of National Bureau of Standards, changes in.....	14	9
TBC-3 transmitters, electrical alignment of filament induction voltage regulators in.....	15	38
TBS equipment, comments on.....	15	49
TBS series, modification.....	14	16
TBX series transmitters, extending frequency range of.....	14	32
TBY series, repair of switches in.....	15	38
TCM-2 equipments, correction of microphone jack wiring.....	14	21
TDQ transmitting equipment, description of.....	14	1
Tropical conditions, effect of on R.F. transmission lines.....	16	6
Type CBK-50142 noise limiters, effectiveness of.....	15	27
Type CWL-861 tubes, new containers for.....	16	23
Type 861 vacuum tube, storage of spares.....	13	49
Vacuum tubes, instructions on.....	14	17
Vacuum tube test data for Model OQ test equipment.....	14	21
U. S. Navy Radio and Sound Laboratory, San Diego, facilities of.....	15	47
YG and YG-1, modification to control unit drive motor.....	14	31