

TECHNICAL MANUAL
FOR
RADIO RECEIVER
TRANSFER SWITCHBOARD
SB-82/SRR

Manufactured by
TABET MANUFACTURING CO.
1336 Ballentine Blvd.
Norfolk, Virginia

For
ELECTRONICS SUPPLY OFFICE
GREAT LAKES, ILLINOIS

**TECHNICAL MANUAL
FOR
RADIO RECEIVER
TRANSFER SWITCHBOARD
SB-82/SRR**

Manufactured by
**TABET MANUFACTURING CO.
1336 Ballentine Blvd.
Norfolk, Virginia**

For
**ELECTRONICS SUPPLY OFFICE
GREAT LAKES, ILLINOIS**

Contract: N126s-85538

TABLE OF CONTENTS

<u>ITEM</u>		<u>PAGE</u>
1.	Figure 1. Radio Receiver Transfer Switchboard SB-82/SRR, exterior view.	1
2.	Section I. General Description .	2
3.	Figure 2. Radio Receiver Transfer Switchboard, cover open to show interior.	4
4.	Section II. Installation	5
5.	Replacement Parts List	7
6.	Wiring Diagram	8

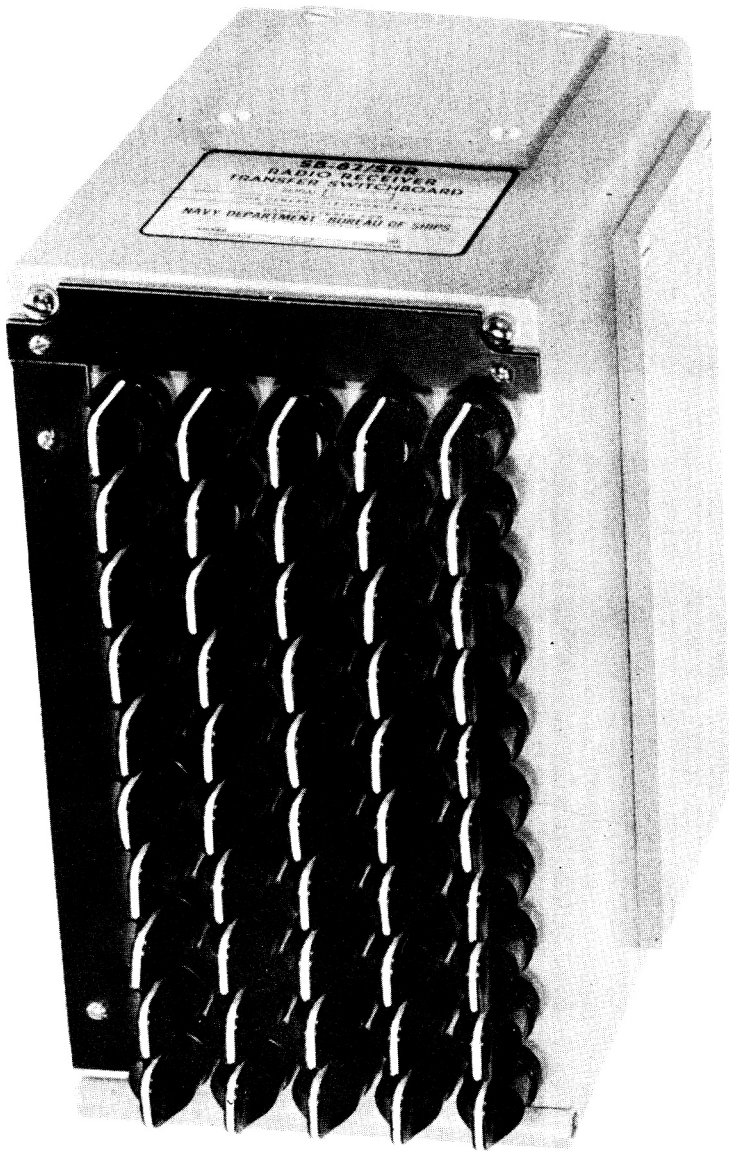

FIGURE 1. Radio Receiver Transfer Switchboard, SB-82/SRR, exterior view.

Section 1

General Description

1. Purpose.

Radio Receiver Transfer Switchboard SB-82/SRR is intended for general electronics use in shipboard installations. It is used to transfer the outputs of one to five receivers to one to ten remote stations.

Figure 1 illustrates the complete unit.

2. Description

Radio Receiver Transfer Switchboard SB-82/SRR consists of an aluminum cabinet containing 50 double pole, single throw switches and a terminal block.

Figure 2 shows an interior view with the panel opened.

It operates on a highly flexible principle, i. e., cross-mat parallel wiring of the switches. The switchboard has five vertical rows of ten double pole, single throw switches, continuously rotatable in either direction.

One side of each switch in a vertical row is wired in parallel with the same sides of the other nine switches in that row. Similarly, the side of each switch that is not wired in parallel vertically, is wired in parallel horizontally with the other sides of each of the other four switches in the same horizontal row — hence the term cross-mat paralleling.

It may readily be seen that with an equipment connected to each horizontal row of switches, any or all equipments may be switched to any or all remote units merely by a turn of the proper switch or switches. The knob of each switch is marked with a heavy white line, providing instant and positive information as to the communication setup. Since in almost every instance a vessel's communication remote control system requires more remote stations than there are equipments, the standard installation of the switchboards will be in a vertical position. Switchboards are furnished with the knobs in the off position when the white line is vertical. This provides for five equipments (vertical rows) and ten remote station (horizontal rows). However, by the simple expedient of turning the switchboard to a horizontal position and rotating each switch knob 90° with respect to its shaft, the switch panel provides for ten equipments and five remotes. The purpose of rotating the switch knobs with respect to the shafts is to standardize on switches being in the off position when vertical. Also for further standardization in every installation, equipments should be connected to the vertical rows of switches, and remote stations connected to horizontal rows, after the position of the switchboard has been determined.

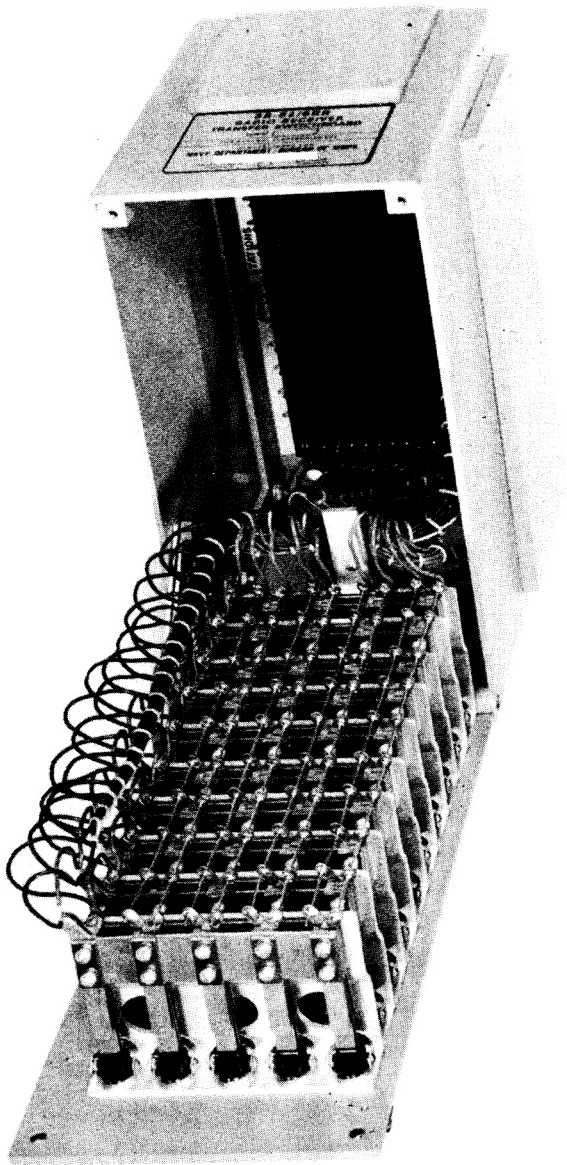

FIGURE 2. Radio Receiver Transfer Switchboard, cover open to show interior.

Section II

Installation

The Radio Receiver Transfer Switchboard is 9" high X 4-5/8" wide X 6" deep. Four 9/32" diameter mounting holes are located on the back of the unit on 3-3/8" X 7-5/8" mounting centers.

All external wiring is brought into the panel through terminal tubes and is connected to a terminal block located in the back of the cabinet. The panels themselves are designed as units and as many units as required for a particular installation may be mounted together on a common bracket. To facilitate interconnections for group installations, two types of cable harnesses for each type panel are provided, one for vertical and one for horizontal interconnections of each type panel.

The number of panels of each type required for a particular installation should be determined by judicious choice of equipments and remote stations. Proper grouping of equipments and remote stations will reduce considerably the number of panels required in the larger vessels.

The fabrication of group panels should be accomplished in the shop. The proper number of panels should be bolted to an appropriate frame and the panels wired together, using the cable harnesses furnished. A 1/32" washer should be inserted between each horizontal switchboard in order to provide clearance for opening the front panels. Switch-

boards should be bolted together utilizing the bolt holes available when the terminal tube plates are removed. To facilitate wiring, the bott screw in the front panel step should be removed and the panel dropped down. Care should be exercised to avoid injury to knobs when the front panel is dropped.

**REPLACEMENT PARTS LIST, RADIO RECEIVER
TRANSFER SWITCHBOARD SB-82/SRR**

REF. DESIG.	NOTES	NAME AND DESCRIPTION	LOCATING FUNCTION	FEDERAL STOCK NUMBER	NO. PER EQPT.
0-101 thru 0-150		KNOB: Set screw type; positive gripping surface; round black phenolic body .875 in. lg by .687 dia; integrally molded skirt; straight shank; accommodates 1/4" dia round shaft; shaft hole 7/16 in. dp; 1 socket-type set screw, #4-40; brass insert .437 in. dia by .265 in. dp; per Department of Navy Electronics dwg RE B 10087.	Switch knob for S-101	N5355-644-1485	50
S-101 thru S-110		SWITCH ASSEMBLY: Rotary; 5 sections; 5 control knobs; 2 switching positions each section, 90 deg apart; per Department of Navy Electronics dwg no. RE B 24000.	Audio Output Transfer Switch	N5930-636-3150	10
W-101		CABLE ASSEMBLY: wiring harness; type "A" for Radio Receiver Transfer Switchboard SB-82/SRR.	--	N5820-643-8166	1
W-102		CABLE ASSEMBLY: wiring harness; type "B" for Radio Receiver Transfer Switchboard SB-82/SRR.	--	N5820-699-2933	1

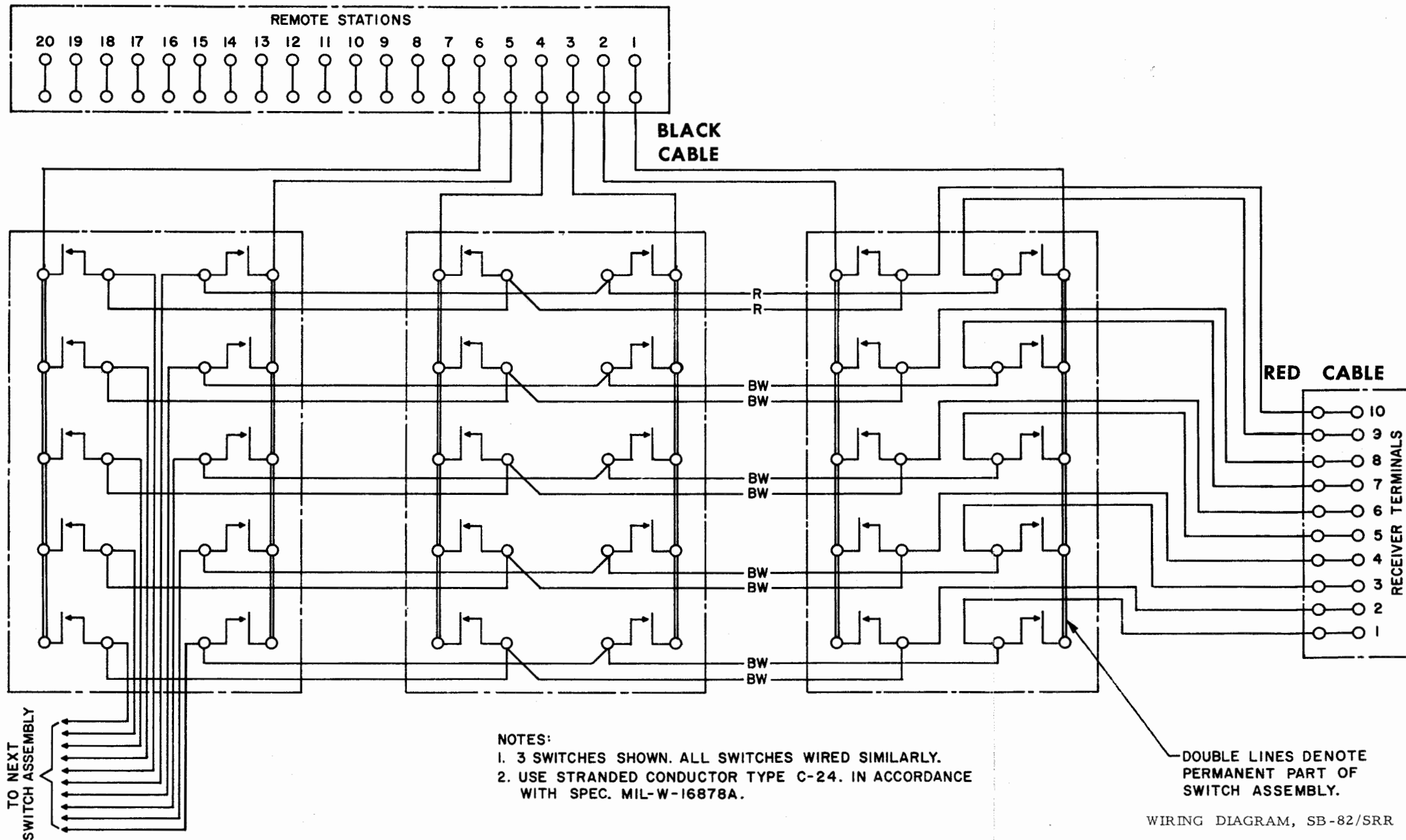

NOTES:

1. 3 SWITCHES SHOWN. ALL SWITCHES WIRED SIMILARLY.
2. USE STRANDED CONDUCTOR TYPE C-24. IN ACCORDANCE WITH SPEC. MIL-W-16878A.

DOUBLE LINES DENOTE PERMANENT PART OF SWITCH ASSEMBLY.

WIRING DIAGRAM, SB-82/SRR