

BULLETIN 138B

ADJUSTMENTS

TYPE BAR PAGE PRINTER

MODELS 15 AND 20



TELETYPE[®]
CORPORATION

5555 TOUHY AVENUE, SKOKIE, ILLINOIS

LIST OF EFFECTIVE PAGES

FEBRUARY, 1964

(Supersedes Issue dated November, 1961)

Page Number	Change In Effect
A	Change 3
Aa	Change 1
B	Original
C to H	Change 2
1-1 to 1-3	Change 1
1-4 to 1-6	Change 2
1-7	Original
1-8 to 1-18	Change 1
1-19 to 1-21	Change 2
1-22 to 1-31	Change 1
1-32	Change 2
1-33	Change 1
1-34	Change 2
1-35 to 1-36B	Change 1
1-37 to 1-40	Original
1-41	Change 2
1-42 to 1-54	Original
1-55 to 1-57	Change 2
1-58 to 1-63	Original
1-64	Change 1
1-64A	Change 3
2-0 to 2-1	Change 2
2-2 to 2-4	Change 1
2-5	Change 2
3-1	Original
3-2	Change 3
3-3 to 3-5	Original
3-6	Change 1
3-7 to 3-8	Original
3-9	Change 1
3-10 to 3-26	Original
3-27 to 3-28	Change 1
3-29	Change 2

The above list indicates the effective pages as of the date of issue. Upon receipt of change pages, insert them numerically and discard any superseded pages.

138B

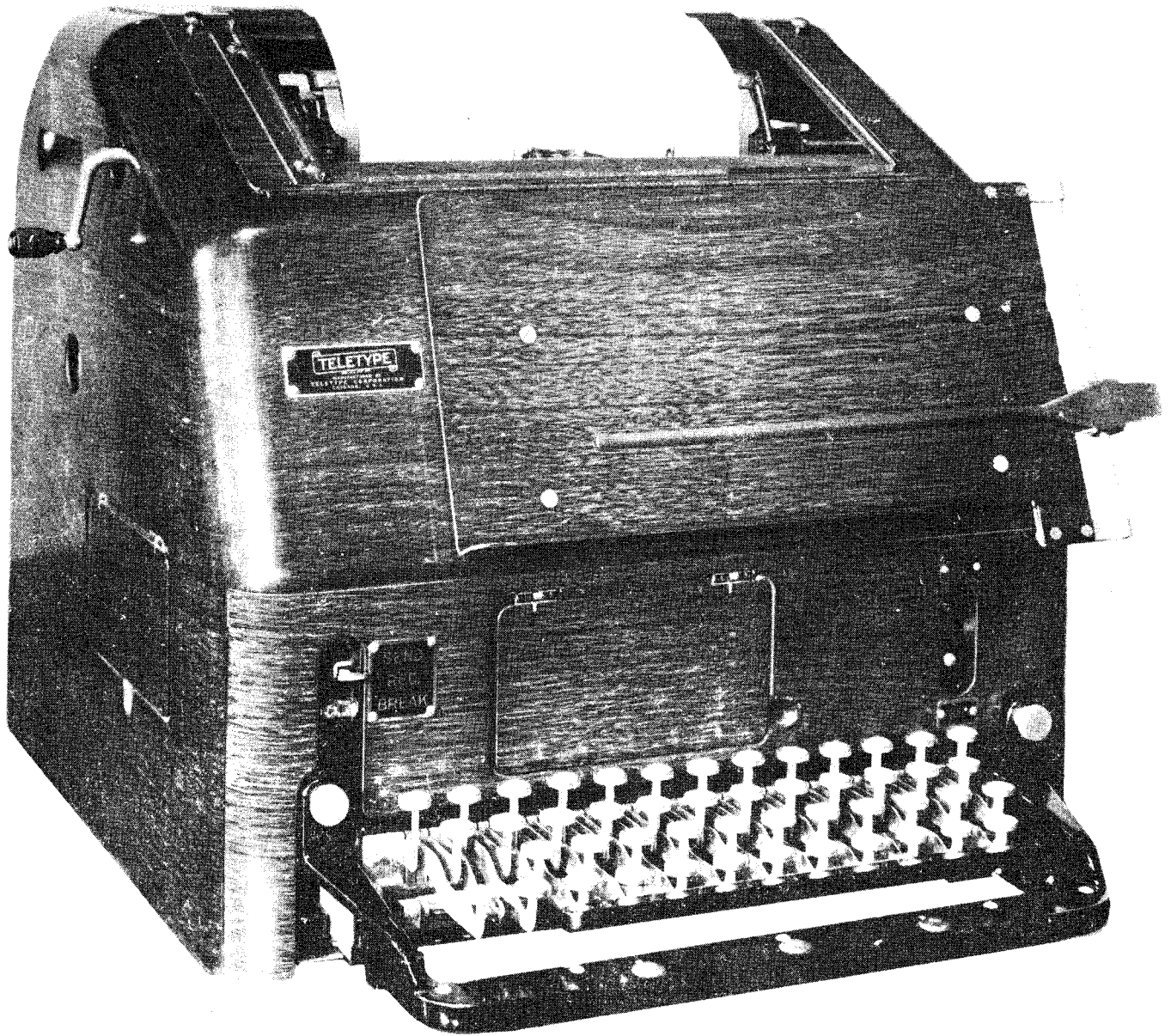

MODEL 20 TYPE BAR PAGE PRINTER

CHANGE 1

Aa

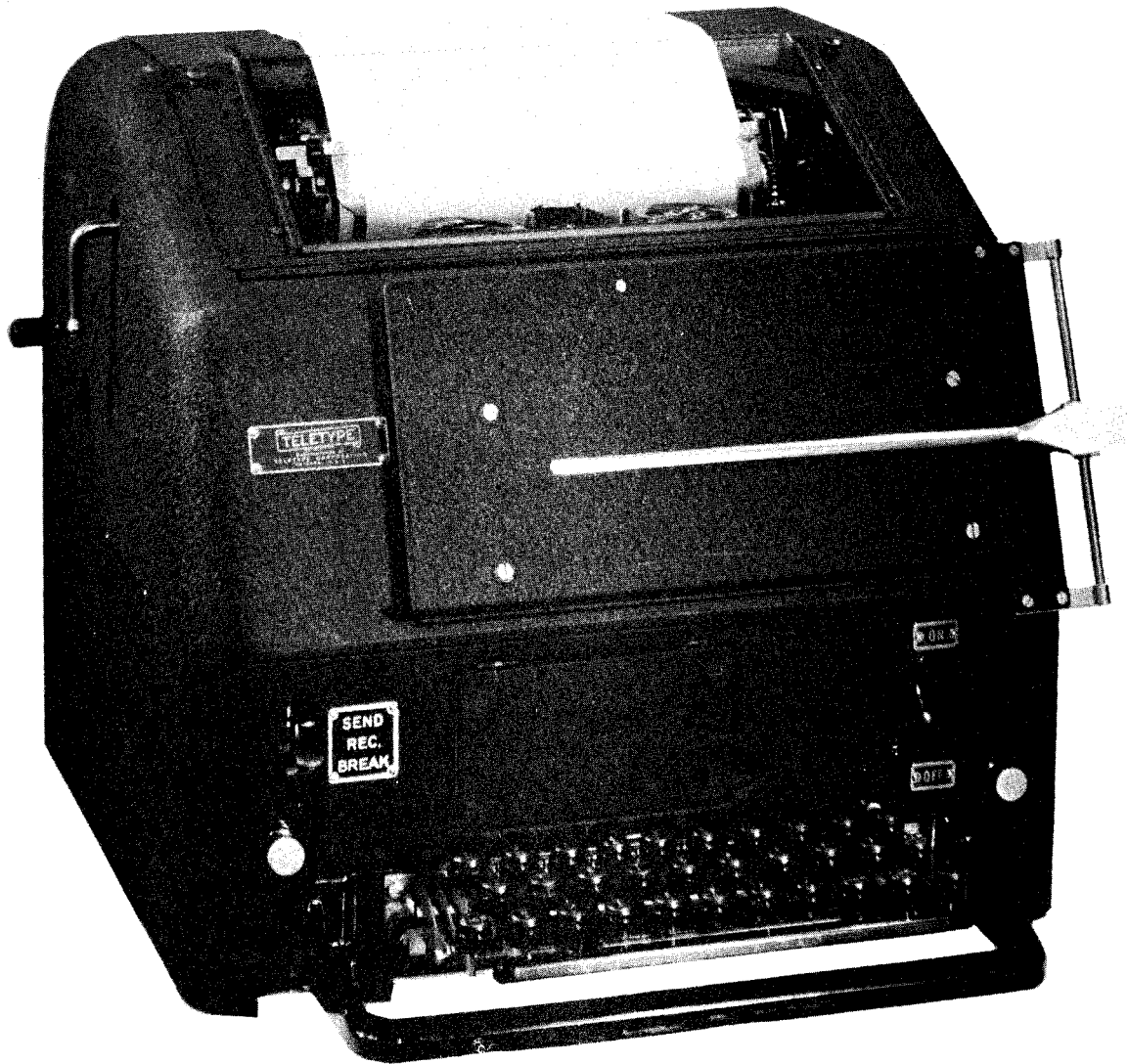

MODEL 15 TYPE BAR PAGE PRINTER

TABLE OF CONTENTS

Paragraph	Page	Paragraph	Page
SECTION 1 - ADJUSTMENTS			
1. General	1-1	30. Ribbon Oscillator Lever Spring Torsion	1-8
2. Miscellaneous Instructions		31. Ribbon Shift Lever Spring Tension	1-8
a. Manual Selection of Characters or Functions	1-1	32. Margin Bell Pawl Spring Tension	1-8
b. Adjusting Motor Speed	1-1	33. Ribbon Lockout Bar Detent Spring Pressure	1-8
c. Orientation	1-1	34. Ribbon Lockout Bar Detent Spring Pressure	1-8
d. Removal of Type Bar Carriage from Typing Unit	1-2	35. Right Pull Bar Spring Bracket	1-8
e. Removal of Type Bar Segment from Type Bar Carriage	1-2	36. Left Pull Bar Spring Bracket	1-9
f. Removal and Replacement of Type Bars	1-2	37. Margin Adjusting Screw Arm Spring Pressure	1-9
g. Removal and Replacement of Code Bars	1-3	38. Carriage Support and Pull Bar Bail Plunger Rollers	1-9
h. Mounting the Bell Crank Assembly	1-3	39. Main Shaft	1-9
i. Replacing the Type Bar Carriage	1-3	40. Main Shaft Jaw Clutch Throwout Lever	1-9
TYPING UNIT			
3. Plunger Guide Roller Bracket Preliminary	1-4	41. Main Shaft Jaw Clutch Throwout Lever Spring Tension	1-9
4. Flanged Guide Roller	1-4	*42. Main Shaft Jaw Clutch Spring Tension	1-9
5. Plunger Guide Roller Bracket Final	1-4	43. Spacing Shaft Lower Bearing Bracket	1-10
6. Plunger Roller Eccentric Mounting Stud	1-4	44. Printing Bail Shaft Right Bearing	1-10
7. Pull Bar Spring Tension	1-4	45. Printing Bail	1-10
8. Ribbon Feed Pawl Spring Tension	1-4	46. Function Lever Bail	1-10
9. Code Bar Mounting Plate (Pull Bar Guide)	1-4	47. Blocking Plate	1-10
10. Ribbon Feed Shaft Bearing Plates	1-5	48. Function Lever Bail - One Piece	1-11
11. Ribbon Feed Shaft Detent Spring	1-5	49. Sixth Vane Extension Spring Compression	1-11
12. Ribbon Feed Shaft Detent Spring Pressure	1-5	50. Sixth Vane	1-11
*12.1 Ribbon Ratchet Shaft Gears Backlash	1-5	51. Selector Vanes	1-12
13. Vertical Ribbon Feed	1-5	52. Function Bail Spring Tension	1-12
14. Ribbon Spool Brackets	1-5	*53. Printing Bail Spring Tension	1-12
15. Ribbon Spool Shaft Spur Gears	1-5	54. Selector Armature Bracket Link Friction	1-12
16. Vertical Ribbon Feed Shaft Spur Gears	1-5	55. Selector Lever Spring	1-12
17. Ribbon Spool Cups	1-6	56. Selector Separator Plate	1-12
*18. Vertical Ribbon Feed Shaft Spring Tension	1-6	57. Selector Armature	1-12
19. Ribbon Reverse Arms Ribbon Guide Slot	1-6	58. Selector Armature Bracket Link	1-13
20. Ribbon Reverse Shafts	1-6	59. Selector Armature Bracket	1-13
21. Ribbon Reverse Shafts Collars	1-6	60. Armature Stops	1-14
22. Ribbon Reverse Shafts Links	1-6	61. Armature Locking Wedge	1-14
23. Ribbon Spool Cups and Ribbon Reverse Arm Backstop	1-7	62. Armature Locking Lever Spring Tension	1-15
24. Ribbon Reverse Arm Yield Spring Tension	1-7	63. Stop Lever Eccentric Screw	1-15
25. Ribbon Reverse Pawl Spring Tension	1-7	64. Stop Lever Spring Tension	1-15
26. Ribbon Reverse Bail Spring Compression	1-7	65. Trip Latch Spring Compression	1-15
27. Type Bar Backstop (Rigid Type)	1-7	66. Selector Stop Arm and Stop Lever Engagement	1-15
28. Type Bar Backstop (Floating Type)	1-7	67. Armature Trip-Off Eccentric Screw	1-15
29. Ribbon Shift Lever Bracket	1-8	68. Selector Magnet Coil	1-16
		69. Magnet Bracket	1-16
		70. Selector Separator Plate	1-16
		71. Armature Pivot Screw	1-16
		72. Selector Core and Armature Alignment	1-16

*See NOTE (K) on Page 1-4.

Paragraph	Page	Paragraph	Page
73. Selector Arm Pivot Screw	1-17	120. Pressure Roller Release Lever Shafts	1-25
74. Selector Arm Bracket	1-17	121. Paper Chute Spring Tension	1-25
75. Locking Wedge	1-17	122. Paper Chute	1-25
*76. Locking Lever Spring Tension	1-17	123. Paper Fingers	1-25
77. Selector Arm Stop Detent	1-17	124. Paper Fingers Shaft Spring Tension	1-26
*78. Selector Arm Stop Detent Spring Tension	1-18	125. Paper Straightener Rod Stops	1-26
79. Selector Lever Spring Tension	1-18	126. Paper Straightener Rod Spring Tension	1-26
80. Selector Magnet Bracket Position	1-18	127. Paper Guides	1-26
81. Selector Magnet Bracket	1-18	128. Spacing Escapement Pawl Operating Arm	1-26
*82. Armature Lever Spring Tension	1-19	129. Spacing Escapement Pawl Spring Tension	1-26
83. Selector Arm Operating Screw	1-19	130. Margin Bell Hammer	1-26
*84. Selector Arm Spring Tension	1-19	131. Margin Bell Hammer Spring Tension	1-26
85. Stop Lever Eccentric Screw	1-19	132. Signal Bell Hammer Spring Tension	1-26
*86. Trip Latch Spring Compression	1-19	133. Signal Bell Latch Bar Latch Shims	1-26
87. Stop Lever Spring Tension	1-19	134. Signal Bell Latch Bar Latch	1-27
88. Selector Stop Arm and Stop Lever Engagement	1-19	135. Signal Bell Hammer Backstop	1-27
89. Trip-Off Screw	1-20	136. Signal Bell Operating Lever Spring Tension	1-27
89.1 Armature Detent Mounting Bracket	1-20	137. Signal Bell Reset Bar Spring Tension	1-27
89.2 Armature Detent Spring Tension	1-20	138. Bell Function Lever Spring Tension	1-27
90. Platen Unit Pilot Screws	1-20	139. Carriage Return Latch Bar Latch Shims	1-27
91. Platen Shift-Unshift Stop Post	1-20	140. Carriage Return Latch Bar Latch	1-27
*91.1 Letters and Figures Stop Screw	1-20	141. Carriage Return Lock Bar Latch Eccentric Screw	1-27
92. Unshift (Letters) Stop Screw	1-20	142. Carriage Return Lock Bar Latch Spring Tension	1-28
93. Shift (Figures) Stop Screw	1-20	143. Carriage Return Lock Bar	1-28
94. Shift (Figures) Unshift (Letters), and Line Feed Function Lever Spring Tensions	1-21	144. Carriage Return Operating Lever Stop Screw	1-28
95. Space Function Lever Spring Tension	1-21	145. Carriage Return Reset Bar Spring Tension	1-28
96. Blank Printing and Spacing Cutout Function Lever Spring Tension	1-21	146. Carriage Return Function Lever Spring Tension	1-28
97. Function Bail Blade	1-21	147. Carriage Return Operating Lever Spring Tension	1-28
98. Unshift on Space Cutout Lever	1-21	148. Carriage Return Clutch Spring Compression	1-28
99. Shift (Figures) and Unshift (Letters)	1-22	149. Dashpot Lever Spring Tension	1-29
100. Platen Balance Spring Tension	1-22	150. Spacing Stop Lever Bracket	1-29
101. Shift-Unshift Detent	1-22	151. Spacing Stop Lever Spring Tension	1-29
102. Shift-Unshift Detent Spring Tension	1-22	152. Carriage Guide Screws	1-29
103. Sixth Vane Extension	1-22	153. Code Bar Bell Cranks	1-29
104. Unshift (Letters) and Shift (Figures) Push Bar Spring Tensions	1-23	154. Spacing Rack	1-29
105. Platen Shaft	1-23	155. Locking Function Lever Spring Tension	1-30
106. Single-Double Line Feed Detent	1-23	156. Sixth Vane Detent Spring Tension	1-30
107. Single-Double Line Feed Detent Spring Pressure	1-23	157. Carriage Return Spring Drum	1-30
108. Line Feed Detent Lever	1-23	158. Paper Spindle Drag Spring	1-30
109. Line Feed Link Turnbuckle	1-23	159. Platen Friction Assembly	1-30
110. Line Feed Push Bar Spring Tension	1-23	160. Send-Receive T Lever Friction Washer	1-30
111. Line Feed Detent Lever Spring Tension	1-24		
112. Line Feed Pawl Spring Tension	1-24		
113. Line Feed Check Screw	1-24		
114. Line Feed Check Post Stop Screw	1-24		
115. Line Feed Check Lever	1-24		
116. Line Feed Check Lever Spring Tension	1-24		
117. Pressure Roller Release Shaft Collars	1-24		
118. Pressure Roller Release Cams	1-25		
119. Pressure Roller Spring Tension	1-25		

*See NOTE (K) on Page 1-4

Paragraph	Page	Paragraph	Page
161. Universal Function Lever Spring Tension	1-31	201. Line Relay Jack Contact Spring Tension	1-36b
162. Blank Function Lever Spring Tension	1-31	202. Upper Contact Lever Spring Tension	1-36b
163. Send-Receive Mechanism Plate	1-31	203. Lower Contact Lever Spring Tension	1-36b
164. Intermediate Lever Stop Bracket	1-31	204. Safety Pawl Spring Tension	1-36b
165. Intermediate Lever Spring Tension	1-31	205. Send-Receive-Break Contact Springs	1-36b
166. Motor Plate	1-31	206. Stop Lever Plate	1-37
167. Send-Receive Reset Lever Upper Adjusting Screw	1-32	207. Break Lever Adjusting Plate	1-37
168. Left Margin Adjusting Screw	1-32	208. Stop Lug	1-37
169. Right Margin Adjusting Screw	1-33	209. Upper Contact Lever Spring Tension	1-37
169.1 Stop Plate	1-33	210. Stop Lever Spring Tension	1-37
170. Ribbon Oscillator Lever	1-33	211. Send-Receive-Break Contact Springs	1-37
171. Ribbon Lockout Bar	1-33	212. Control Relay	1-37
172. Spacing Clutch Torque	1-33	213. Send-Receive-Break Mechanism (Single Upper Contact)	1-38
173. Margin Signal Bell	1-33	214. Send-Receive-Break Mechanism (Two Upper Contacts)	1-39
173.1 Selector Cam Sleeve Assembly	1-34		
*174. Selector Clutch Torque	1-34	CENTER CONTACT GOVERNOR	
175. Bail Cam Unit Friction Clutch Torque	1-34	215. Alignment and Squareness of Governor Contacts	1-39
176. Dashpot Vent Screw	1-34	216. Speed Adjusting Wheel Friction Washer Spring Tension	1-39
KEYBOARD UNIT		217. Inner and Outer Disc Contact Spring	1-39
177. Lock Loop Spring Tension	1-34	218. Governor Brush Spring Plate Bracket	1-39
178. Locking Lever Shaft Bracket	1-34	219. Governor Brush Spring Pressure	1-40
178.1 Selector Bar Assembly Bracket Shims	1-34	220. Governor Adjusting Bracket	1-40
178.2 Selector Bar Assembly Bracket Position	1-35	221. Speed Adjusting Lever Stop Plate	1-40
*179. Transmitting Contacts Gap	1-35	222. Governor Shims	1-40
180. Contact Spring Pressure	1-35	SYNCHRONOUS MOTOR	
181. Clutch Spring Compression	1-35	223. Synchronous Motors with Three Brush Starting Switch	1-40
182. Clutch	1-35		
183. Lock Loop Roller	1-35	VARIABLE FEATURES SPROCKET FEED PRINTERS	
184. Universal Bar Pilot Screws	1-35	224. Left Pressure Roller Lever	1-41
185. Trip-Off Pawl Stop Plate	1-35	225. Right Pressure Roller Lever Spring Collar	1-41
185.1 Universal Bar Bearing Brackets	1-36	226. Right Pressure Roller Lever Spring Tension	1-41
186. Intermediate Pawl Eccentric	1-36	227. Left Pressure Roller Spring Tension	1-41
187. Clutch Throwout Lever Eccentric	1-36	228. Paper Stripper	1-41
188. Trip-Off Pawl Eccentric	1-36	229. Pulley Collars	1-41
189. Clutch Throwout Lever Spring Tension	1-36	230. Left Margin Adjusting Screw	1-41
190. Trip-Off Pawl Spring Tension	1-36	231. Platen Friction Assembly	1-42
191. Transmitting Cam Cylinder End Play	1-36	232. Platen Roller Sprocket Rings	1-42
192. Key Lever Spring Tension	1-36	233. Paper Guide Posts	1-42
193. Repeat Space Rod	1-36		
194. Repeat Space Rod Bracket	1-36a	*See NOTE (K) on Page 1-4	
195. Repeat Space Rod Spring Tension	1-36a		
BASE UNIT			
196. Motor Unit Slip Connection Springs	1-36a		
197. Line Jack Springs	1-36a		
198. Keyboard Jack Springs	1-36a		
199. Typing Unit Slip Connection Spring	1-36a		
200. Line Relay Jack Contact Gap	1-36b		

Paragraph	Page	Paragraph	Page
234. Cover Paper Guide Posts	1-42	269. Tabulator Bar	1-48
PLATEN INDEXING MECHANISM FOR SPROCKET FEED PRINTERS		270. Contact Lever Screw	1-48
235. Contact Lever Eccentric	1-43	271. Tabulator Latch	1-48
236. Platen Friction Assembly	1-43	272. Tabulator Latch Bar Extension	1-48
237. Removable Gears	1-43	273. Tabulator Stops	1-48
238. Cam Clutch Torque	1-43	274. Transmitter Distributor Control Contact	1-49
239. Contact Lever Spring Tension	1-43	275. Tabulator Function Lever Spring	1-49
MECHANICAL MOTOR STOP		276. Tabulator Latch Bar Spring	1-49
240. Motor Stop Lever Bracket	1-43	277. Tabulator Bar Spring	1-49
241. Motor Stop Lever Eccentric	1-43	278. Front Spacing Escapement Pawl	1-49
242. Motor Stop Lever Backstop Screw	1-44	SWITCH CUT-IN AND AUTOMATIC CUT-OUT OF HORIZONTAL TABU- LATION	
243. Motor Stop Pawl Backstop	1-44	279. Spacing Stop Lever Bracket	1-49
244. Motor Stop Release Lever Eccentric	1-44	280. Blocking Lever Extension Bracket	1-50
245. Motor Stop Pawl Spring Compression	1-44	281. Magnet Bracket Position	1-50
246. Motor Stop Lever Spring Tension	1-44	282. Signal Bell Hammer Backstop	1-50
247. Motor Stop Contact Lever Spring Tension	1-44	283. Locking Contact	1-50
248. Motor Stop Function Lever Spring Tension	1-44	284. Spacing Stop Lever Spring Tension	1-50
249. Right Motor Stop Contact	1-44	285. Blocking Lever Spring Tension	1-50
250. Left Motor Stop Contact	1-45	286. Right Margin Adjusting Screw	1-51
251. Reset Lever Lower Adjusting Screw	1-45	REPERFORATOR MOTOR CONTROL MECHANISM	
252. Reset Lever Downstop Screw	1-45	287. Reperforator Control Plate	1-51
SHIFT-BLANK-STOP MECHANICAL MOTOR STOP		288. Reperforator Control Contact	1-51
253. Adapter Plate (Trigger Assembly)	1-45	289. Contact Pawl Spring Tension	1-51
254. Trigger Guide	1-45	290. Reperforator Control Function Lever Spring Tensions	1-51
255. Blocking Lever Spring	1-46	AUTOMATIC CARRIAGE RETURN AND LINE FEED	
UPPER CASE "H" ELECTRICAL MOTOR CONTROL FOR UNITS EQUIPPED WITH A HOLDING MAGNET SELECTOR		291. Carriage Return Latch Bar Latch Shims	1-51
256. Motor Stop Function Lever Spring Tension	1-46	292. Carriage Return Function Lever Eccentric Screw	1-51
257. Motor Stop Contact	1-46	293. Operating Bail Line Feed Extension	1-52
258. Start Magnet Core	1-46	294. Automatic Carriage Return and Line Feed Function Lever Eccentric Screw	1-52
259. Stop Magnet Core	1-46	295. Mounting Bracket	1-52
260. Start Magnet Bracket	1-47	296. Trigger Guide	1-52
261. Stop Magnet Bracket	1-47	297. Trigger Adjustable Screw	1-52
262. Armature Stop	1-47	298. Carriage Return and Automatic Carriage Return and Line Feed Function Lever Spring Tensions	1-52
263. Latch Backstop Screw	1-47	299. Trigger Spring Tension	1-53
264. Stop Magnet Armature Spring Tension	1-47	300. Bell Crank Retainer Yield Lever Spring Tension	1-53
265. Start Magnet Armature Spring Tension	1-47	301. Line Feed Link Turnbuckle	1-53
266. Latch Spring Tension	1-47	TWO COLOR RIBBON CONTROL	
267. Inner Contact Assembly	1-47	302. Ribbon Oscillator Lever	1-53
268. Outer Contact Assembly	1-47	HORIZONTAL TABULAR MECHANISM	

Paragraph	Page	Paragraph	Page
303. Ribbon Oscillator Lever Latch Bracket	1-53	336. Contact and Backstop Bracket	1-58
304. Ribbon Oscillator Latch Spring Tension	1-53	337. Contact Lever Latch Mounting Screw	1-58
305. Ribbon Oscillator Lever Adjustable Stop	1-53	338. Upper Contact Spring Tension	1-58
306. Parallelogram Bar Brackets	1-53	339. Lower Contact Spring Tension	1-59
307. Magnet Yoke	1-54	340. Contact Gap	1-59
308. Armature Eccentric Backstop	1-54	341. Signal Bell Hammer Backstop Screw	1-59
309. Armature Spring Tension	1-54	342. Contact Lever Latch Adjusting Screw	1-59
310. Contact Operating Lever Bracket	1-54	343. Contact Lever Latch Spring Tension	1-59
311. Contact Springs	1-54		
312. Link	1-55		
313. Contact Operating Lever Spring Tension	1-55	STATION SELECTOR PRINTERS	
314. Two Color Mechanism No. 5 and No. 6 Function Lever Spring Tensions	1-55	344. Call Contacts	1-59
315. Loading Plate	1-55	345. Call Contact Function Lever Spring Tension	1-59
316. Type Bar Guide	1-55	346. Transfer Contacts	1-59
		347. Transfer Contact Lever Spring Tension	1-60
MECHANICAL WORD COUNTER		348. Transfer Contact Function Lever Spring Tension	1-60
317. Star Wheel Tangential Tension	1-55	349. Function Lever Bail	1-60
318. Counter Assembly Position	1-55	350. Disconnect Contact	1-60
319. Operating Linkage	1-56	351. Keylever Link	1-60
320. Slide Lever Spring Tension	1-56	352. Bail Spring Tension	1-60
321. Link Yield Spring Tension	1-56	353. Bail Backstop	1-60
		354. Answer-Back-Magnet Heel Piece Air Gap	1-60
ELECTRICAL WORD AND OPERATIONS COUNTER		355. Bail	1-61
322. Star Wheel Tangential Tension	1-56		
322.1 Operating Lever Position	1-56	100 WPM KEYBOARD	
323. Contact Requirements	1-56	356. Transmitting Contact Gap	1-61
324. Contact and Bracket Assembly	1-56	357. Transmitting Contact Spring Stiffener	1-61
325. Operating Linkage	1-57	358. Lock Loop Backstop Screw	1-61
326. Slide Lever Spring Tension	1-57		
327. Link Yield Spring Tension	1-57	KEYBOARD CAM OPERATED CONTACTS	
		359. Pulsing Contact	1-61
FEEDING FOUR LINES PER INCH			
328. Line Feed Link Turnbuckle	1-57	MECHANISM FOR OPENING AND CLOSING EXTERNAL CIRCUITS	
329. Line Feed Check Screw	1-57	360. Left Contact Assembly	1-61
		361. Left Function Lever Spring Tension	1-61
END OF LINE PRINTING AND SPACING		362. Right Contact Assembly	1-61
330. Printing and Spacing Cutout Mechanism Bracket	1-57	363. Contact Lever Spring Tension	1-62
331. Printing Cutout Latch Eccentric Bushing	1-57	364. Right Function Lever Spring Tension	1-62
332. Right Margin Adjusting Screw	1-58		
333. Printing Cutout Latch Downstop Eccentric	1-58	END-OF-LAST-FORM INDICATING MECHANISM MOUNTED ON TYPING UNIT OF SPROCKET FEED PRINTERS	
334. Spacing Stop Lever Spring Tension	1-58	365. Paper Out Bail	1-62
335. Printing Cutout Latch Spring Tension	1-58	366. Line Feed Detent Lever	1-62
		367. Paper Out Bail Spring	1-62
REMOTE SIGNAL BELL CONTACT (WITH LATCH)			

Paragraph	Page	Paragraph	Page
368.	Vertical Link Eccentric	1-62	
369.	Switch Mounting Plate	1-62	
END-OF-LAST-FORM INDICATING MECHANISM MOUNTED ON COVER OF SPROCKET FEED PRINTERS			
370.	Contact Gap Spring	1-63	
371.	Contact Lever Spring Tension	1-63	
FORM ACCUMULATING SHELF			
372.	Shield Position	1-63	
SPROCKET FEED TEARING EDGE AND PAPER GUIDE			
373.	Paper Stripper	1-63	
374.	Paper Guide Plate	1-63	
375.	Tearing Edge Mounting Bracket	1-63	
376.	Tearing Edge Blade	1-63	
377.	Cover Gap	1-63	
378.	Margin Guide Adjustment	1-63	
PAPER OUT MECHANISM			
379.	Switch Plunger Overtravel	1-64	
380.	Paper Follower Arm	1-64	
381.	Paper Follower Arm Spring Tension	1-64	
382.	Ribbon Oscillator Lever	1-64	
383.	Ribbon Oscillator Adjustable Stop	1-64	
384.	Spring Contacts	1-64	
385.	Contact Lever Adjusting Screw	1-64	
UPPER CASE "H" OR "BLANK" CONTACTS			
386.	Typing Unit Slip Connection Spring	1-64a	
387.	Upper Case "H" Contact Assembly	1-64a	
388.	Upper Case "H" Function Lever Spring Tension	1-64a	
389.	Signal Bell Latch Bar Latch	1-64a	
390.	Carriage Return Latch Bar Latch	1-64a	
391.	Blank Contact Bracket	1-64a	
392.	Blank Contact Assembly	1-64a	
SECTION 2 - LUBRICATION			
1.	General	2-1	
2.	Typing Unit	2-1	
a.	Type Bar Carriage Assembly	2-1	
3.	Typing Unit Less Type Bar Carriage Assembly	2-1	
a.	Platen Unit	2-1	
b.	Main Shaft	2-2	
c.	Selector Unit	2-2	
d.	Bail Unit Assembly	2-2	
e.	Vane Frame Assembly	2-3	
f.	Spacing Shaft Assembly	2-3	
g.	Carriage Return Mechanism	2-3	
h.	Bell Function	2-3	
i.	Shift-Unshift Mechanism	2-3	
j.	Line Feed Function	2-4	
4.	Motor Unit	2-4	
5.	Base	2-4	
6.	Keyboard	2-4	
a.	Bottom Side of Keyboard	2-4	
b.	Top Side of Keyboard	2-4	
7.	Variable Features	2-4	
a.	Sprocket Feed	2-4	
b.	Plate Indexing Mechanism	2-4	
c.	Mechanical Motor Stop Mechanism	2-5	
d.	Electrical Motor Stop Mechanism	2-5	
e.	Horizontal Tabulator Mechanism	2-5	
f.	Switch Cut-In and Automatic Cut-Out of Horizontal Tabulator	2-5	
g.	Reperforator Motor Control Mechanism	2-5	
h.	Two-Color Ribbon Mechanism	2-5	
i.	End-of-Last Form Indicating Mechanism	2-5	
j.	Paper Out Mechanism	2-5	

SECTION 1

ADJUSTMENTS

1. GENERAL

a. The following requirements and adjusting procedures for the maintenance of the Teletype Model 15 or 20 Printer are arranged in a sequence that would be followed if a complete re-adjustment of a unit were undertaken. In following such a procedure, parts or assemblies which are removed to facilitate adjustment should not be replaced until all other adjustments are made which would be facilitated by the removal of these parts. If any adjustment is changed, related adjustments should be checked.

b. The spring tension values indicated in this bulletin are scale readings which should be obtained when Teletype scales are used as specified. Springs which do not meet the requirements specified and for which no adjusting procedure is given, should be replaced by new springs. Ordering information may be obtained from the Teletype Model 15 or 20 Printer parts bulletin.

c. Before proceeding with any adjustment, read the applicable portion of the adjusting text carefully. After the adjustment is completed, be sure to tighten any screws or nuts which may have been loosened. If a part that is mounted on shims is to be dismantled, the number of shims used at each of its mounting screws should be noted so that the same shim pile-ups can be replaced when the part is remounted.

d. In addition to the standard adjustments, a number of variable features appear toward the rear of Section 1. Where adjustments of these variable features affect the adjusting sequence, cross reference information has been included in the standard adjustments. Variable features which do not affect the adjusting sequence may be done at any time.

NOTE

In all the figures of this bulletin, fixed pivot points are designated by solid black circles.

2. MISCELLANEOUS INSTRUCTIONS

a. MANUAL SELECTION OF CHARACTERS OR FUNCTIONS

When the text of any adjustment in this bulletin specifies the setting up of a certain

character or function, the following method should be used. Rotate the main shaft until the printing bail is in its extreme rear position. Hold down the front edges of those vanes which correspond to the marking impulses of the combination to be set up (see Figure 1 for code combination chart). Then rotate the main shaft in accordance with the instructions outlined in the applicable adjustment text.

b. ADJUSTING MOTOR SPEED

(1) When AC or DC governed motor units are used, a tuning fork (speed indicator) is supplied for the purpose of checking the motor speed. The tuning fork is equipped with shutters attached to the ends of the tines. The governor of the motor is equipped with a speed target of alternate black and white spots.

(2) With the motor running and the target well illuminated, tap the tuning fork lightly to start it vibrating. Hold the fork close to the eye and view the spots on the target through the vibrating shutters. If the motor is running at the correct speed, the spots will appear to be stationary. If the motor is running too fast, the spots will appear to be moving in the direction in which the motor is rotating; if too slow, in the opposite direction. The speed may be increased or decreased by momentarily pressing against the speed adjusting lever or the governor adjusting bracket respectively.

NOTE

There is a possibility of setting the speed incorrectly, due to getting a speed multiple; i.e., the speed could be half the desired speed, or two thirds the speed, or some other multiple, even though the spots appeared to be stationary when viewed through the tuning fork shutters. This should be kept in mind if trouble is experienced in the operation of the printer.

(3) No speed setting is required on printers equipped with synchronous motors since they are constant speed motors.

c. ORIENTATION

(1) The range finder assembly, which is used for the purpose of orienting the selector to

the incoming signals, is mounted at the left end of the main shaft. Before measuring the receiving range of a printer equipped with a pulling magnet selector, the armature spring tension should be set as follows:

(a) When a distortion test set is available for measuring the receiving margins of a printer, the armature spring tension should measure from 6 to 7 ounces in order to obtain the specified margins. This tension should be checked with the armature in the marking position and the spring stretched to its position length.

(b) When no distortion test set is available, but the printer is equipped with a line relay, the armature spring tension should measure from 6 to 6-3/8 ounces under the same conditions as in (a) above.

(c) When no distortion test set is available and the printer is not equipped with a line relay, turn the armature spring adjusting screw in a clockwise direction while receiving a test message until errors appear in the copy. Then, from this point, count the number of turns that the adjusting screw can be turned in a counter-clockwise direction before errors again appear in the copy. Turn the adjusting screw backward (clockwise) half this number of turns to a point midway between the two failing points (the middle of the armature spring range) and lock the adjusting screw with its lock nut.

NOTE

To insure reliable clutch release, the armature spring tension should be checked to ascertain that it is not below 4-1/2 ounces.

If no errors appear in the copy throughout the entire range of the spring, set the spring tension at 6 to 6-3/8 ounces and lock the adjusting screw.

(2) Transmit RY (the letters R and Y sent alternately) to the printer continually while the receiving range is being determined as described in the following paragraphs.

(a) While RY is being received, loosen the index arm thumb screw and shift the index arm of the range finder toward 0 until errors appear in the copy. Then move the arm back slowly until errors no longer appear; at least 72 characters should be received without error. This position indicates one limit of the orientation

range. Note the position of the index arm on the scale.

(b) Determine the opposite end of the receiving range by repeating the foregoing procedure with the index arm near the opposite end of the scale. After the two limits of the receiving range have been found, set the index arm of the range scale midway between these two points.

(3) To measure the receiving range of printers equipped with a holding magnet selector, set the armature spring tension as prescribed in paragraph 82, "ARMATURE LEVER SPRING". Then proceed by transmitting RY as described in paragraph c.(2) above.

d. REMOVAL OF TYPE BAR CARRIAGE FROM TYPING UNIT

Operate the carriage return lock bar, and move the carriage to the extreme right. Operate the dashpot lever, locking the carriage in this position. Hold the carriage return spring drum so that the spring cannot unwind. Then unhook the draw strap from the carriage and hook the eyelet of the strap onto the margin bell hammer spring post. Move the right margin adjusting screw arm to the rear. Operate the carriage return lock bar again and remove the carriage by sliding it off to the right. Refer to paragraph 2.i for replacing the type bar carriage.

e. REMOVAL OF TYPE BAR SEGMENT FROM TYPE BAR CARRIAGE

Remove the type bar backstop, unhook the ribbon carrier from the ribbon oscillator lever, and remove the type bar segment mounting screws. Hold the pull bars out of engagement with the code bar mounting plate (as an aid, use a piece of string or wire under the pull bars), and slide the assembly forward.

f. REMOVAL AND REPLACEMENT OF TYPE BARS

CAUTION

The type bar guide adapter plate, located between the type bar guide and the type bar segment, is positioned at the factory for type alignment and should not be disturbed as it may seriously affect the alignment.

Remove the type bar carriage, the ribbon, the two screws and lock washers mounting the type bar guide to the adapter plate, and the

ribbon carrier after disengaging it from the hook on the ribbon oscillator lever, and then lift the type bar guide off its dowels; raise the type bar in question until it passes the ribbon oscillator lever, then raise the selected pull bar until it is disengaged from the type bar and remove the type bar from its slot in the type bar segment. Insert the new typebar in the slot just vacated engaging the teeth on the pull bar so the top of the pull bar is even with that of the other pull bars when the type bar is resting against its back-stop. (New type bars are usually oversize and the section that fits in the segment will probably have to be stoned down to permit it to operate freely. Do not remove more metal than is necessary for freedom of movement.) Reassemble the type bar guide on the adapter plate using the two screws and lock washers previously removed, and the ribbon carrier on the type bar guide by engaging its lower end in the ribbon oscillator lever hook.

g. REMOVAL AND REPLACEMENT OF CODE BARS

If it becomes necessary to remove one or more code bars from the code bar assembly, the following instructions should be followed carefully. Hold the inner nut on the code bar stop with a wrench and remove the outer nut. The inner nut may then be removed. In replacing the nuts, care must be used, as excessive tightening of the nuts may cause the code bar separator collars to become embedded in the separator washers. Such a condition might prevent the code bars from moving freely. To prevent this, tighten the inner nut slightly, just enough to flatten the lock washer. Then, with a wrench, hold the inner nut in this position while tightening the outer nut.

h. MOUNTING THE BELL CRANK ASSEMBLY

Place the bell cranks in their lowest position, with respect to the code bars, by means of their eccentric bushings (see Figure 17). Then mount the bell crank assembly as follows:

First, mount the right end of the bell crank assembly with one of its mounting screws so that it is friction tight. Then rotate the assembly clockwise and engage all bell cranks with their respective code bars. Replace the left mounting screw and tighten both screws. (See paragraph 153 for CODE BAR BELL CRANKS adjustment.)

i. REPLACING THE TYPE BAR CARRIAGE

Shift the platen to the FIGURES position and rotate the main shaft until the printing bail is in its rear position. Then move the right margin adjusting screw arm on the carriage to the rear so that it is approximately 45 degrees from the vertical. Hold the carriage in the right hand and rest the left front carriage support roller on the right end of the front carriage track, making sure that the carriage guide screw engages the slot in the carriage track. Position the upper gear of the spacing shaft so that the first full tooth on the carriage gear rack engages the hollow directly above the numeral "1" of the part number stamped on the upper spacing gear. Move the carriage slowly to the left until the rear carriage support roller rests on the upper track. Operate the carriage return lock bar and move the pull bar bail to its rearmost position by pushing on the right pull bar bail roller with the right thumb. Move the carriage further to the left, making sure that the bell cranks engage their respective vanes, that the right front carriage support roller and guide screw properly engage the front carriage track, and the pull bar bail roller is between the printing bail baldes. When the carriage has been moved far enough to the left to permit the right margin adjusting screw to clear the spacing stop lever, restore the right margin adjusting screw arm to its normal vertical position, and then shift the carriage to its extreme right position and lock it in place by operating the dashpot lever. Hold the carriage return spring drum so that the spring cannot unwind. Then unhook the eyelet of the draw strap from the margin bell hammer spring post, and hook it over its mounting post on the carriage. Operate the carriage return lock bar to permit the carriage to return to its extreme left position.

NOTES

References are made to the following notes in the applicable adjustments.

- (A) These requirements should be checked with the type bar carriage removed. Paragraph 2.d.
- (B) These requirements should be checked with the type bar segment assembly removed from the type bar carriage. Paragraph 2.e.
- (C) Pertains only to printers equipped with the yield mechanism shown in figure 10B.
- (D) Pertains only to printers not equipped with a yield mechanism as shown in figure 10B.

- (E) These requirements should be checked with the range finder assembly removed.
- (F) Pertains only to friction feed printers.
- (G) Pertains only to printers equipped with a send-receive mechanism.
- (H) These requirements should be checked with the governor adjusting bracket, the brush spring plate, and the governor cover removed.
- (I) Applies only to Model 15 Printer.
- (J) Applies only to Model 20 Printer.
- (K) Applies to units operating at 100 W. P. M.

TYPING UNIT

3. PLUNGER GUIDE ROLLER BRACKET PRELIMINARY (Figure 2) See Note (A) on Page 1-3

There should be not more than .010" clearance between either the right or left end of the pull bar bail and stripper plate when the bail is moved to its extreme forward position. To adjust the position of the pull bar bail with relation to the stripper plate, loosen the plunger guide roller bracket mounting screws and move the bracket to the right or left.

4. FLANGED GUIDE ROLLER (Figure 2) See Note (A) on Page 1-3

The flanged guide roller should be parallel, or within .002" of being parallel, to the surface of the plunger, and both guide rollers should rotate freely. To adjust the flanged roller with relation to the plunger, move the roller end of the bracket up or down with the mounting screws friction tight. Tighten mounting screws.

5. PLUNGER GUIDE ROLLER BRACKET FINAL (Figure 2) See Note (A) on Page 1-3

Operate the pull bar slowly and see that all pull bars start to move away from the code bars simultaneously, within .020". If necessary, relocate the plunger guide roller bracket to the left or right to meet this requirement. Check to see that the flange roller is parallel to the surface of the plunger within .002" and that both guide rollers rotate freely.

6. PLUNGER ROLLER ECCENTRIC MOUNTING STUD (Figure 2) See Note (A) on Page 1-3

There should be some play, not more than .004", between the pull bar bail plunger and the rollers. Check for this play throughout the entire travel of the plunger. Adjust the position of the

eccentric mounting stud to obtain this requirement.

7. PULL BAR SPRING TENSION (Figure 3) See Notes (A) and (B) on Page 1-3

With any spring unhooked from its pull bar, hook an 8 oz. scale in the spring eye and pull vertically. It should require 2-1/2 to 3-1/2 ozs. to pull the spring to its position length. Replace the spring.

8. RIBBON FEED PAWL SPRING TENSION (Figure 4) See Notes (A) and (B) on Page 1-3

With the pull bar bail in its extreme rear position and the carriage held in its normal position, unhook the ribbon feed pawl spring from its post. With an 8 oz. scale held in a horizontal position and hooked in the spring eye, it should require 2-1/4 to 3-1/4 ozs. to pull the spring to its position length. Replace spring.

REPLACE THE TYPE BAR SEGMENT ASSEMBLY, THE TYPE BAR BACKSTOP, AND THE RIBBON CARRIER - SEE PARAGRAPH 2.d.

NOTE

Care should be taken to locate the ribbon lockout bar and detent spring, and the ribbon oscillator lever in their respective slots.

9. CODE BAR MOUNTING PLATE (PULL BAR GUIDE (Figure 5)

With the pull bar bail in its extreme rear position, move the code bars to the right. Then move the pull bar bail opposite the pull bar humps. There should be .008" to .020" clearance between the humps on all pull bars (except the blank pull bar) and the pull bar bail. With the code bars moved to the left position, there should be a like clearance between the blank pull bar hump and the pull bar bail.

NOTE

When checking this adjustment all the play of the pull bar bail should be taken up in a direction to make the clearance a minimum.

To adjust remove the bell crank mounting plate assembly from the type bar carriage, being careful not to bend the bell crank retainers.

Position the code bar mounting plate by means of its elongated mounting holes to secure the specified clearance.

10. RIBBON FEED SHAFT BEARING PLATES
(Figures 6 and 7) See Note (A) on Page 1-3

The left end of the ribbon feed shaft should be flush with or extend not more than .015" over the inner end of the left vertical feed shaft bevel gear teeth, when the ribbon feed shaft is in its left position and the left vertical feed shaft bevel gear is held in engagement with the ribbon shaft gear.

A like condition should exist when the ribbon feed shaft is in its right position and the right vertical feed shaft bevel gear is held in engagement with it. To adjust, loosen the mounting screws of both right and left ribbon spool brackets and move the brackets up as far as the elongated mounting holes will permit. Tighten the mounting screws with the brackets vertical. Adjust the right bearing plate by means of its clamping nuts to meet the first requirement. Adjust the left bearing plate in a like manner with the ribbon feed shaft in its right position to meet the latter requirement.

NOTE

Check the lateral movement of the ribbon feed shaft (movement from one detented position to the other); it should measure at least 3/16 inch. If necessary, refine the RIBBON FEED SHAFT BEARING PLATE adjustment above.

11. RIBBON FEED SHAFT DETENT SPRING
(Figure 6) See Note (A) on Page 1-3

The center of the ribbon feed shaft detent roller should be at the same height as the center of the ribbon feed shaft, and the shaft detent should travel equally on either side of the detent roller when the shaft is moved from its extreme left to its extreme right position or vice versa. To adjust, loosen the mounting screws of the ribbon feed shaft detent spring, and position the spring.

12. RIBBON FEED SHAFT DETENT SPRING PRESSURE (Figure 6) See Note (A) on Page 1-3

Move the ribbon feed shaft to its extreme left position. Hook a 32 oz. scale over the detent roller hub and pull horizontally toward the rear of the type bar carriage. It should require 18 to 26 ozs. to start the roller moving away from the detent. Then move the ribbon feed shaft to its extreme right position and check the pressure of the detent spring in the same manner. To

increase or decrease the spring pressure, remove the spring and bend it. To equalize the pressure, position the spring to right or left.

12.1 RIBBON RATCHET SHAFT GEARS BACKLASH

Due to the shorter bail travel on 100 W. P. M. printers there should be a minimum of backlash in the ribbon ratchet shaft gears to insure proper ribbon feeding. To obtain this condition, tighten the 74511 Friction Spring on the ratchet shaft by bending the straight portion of the spring.

13. VERTICAL RIBBON FEED SHAFTS (Figure 7) See Note (A) on Page 1-3

The lower ends of the right and left vertical ribbon feed shafts should be flush with the outside edges of their respective bevel gears. Adjust by means of the bevel gear set screws, being sure that when the set screws are tightened they bear against the flat faces on the shafts.

14. RIBBON SPOOL BRACKETS (Figure 7)

With the ribbon feed shaft in its left position, the left vertical ribbon feed shaft should have some end play, not more than .015", during one revolution of the vertical ribbon feed shaft bevel gear. The right vertical ribbon feed shaft should have a like amount of end play, when the ribbon feed shaft is in the right position.

NOTE

When checking the vertical feed shaft for end play, take up the bearing play of the ribbon feed shaft in a direction to make the end play of the vertical feed shaft a maximum.

Adjust both right and left ribbon spool brackets by means of their elongated mounting holes to meet this requirement, being sure that the brackets are vertical, and at right angle to the casting.

15. RIBBON SPOOL SHAFT SPUR GEARS (Figure 8)

The ribbon spool shafts should have some end play not more than .006". To adjust, loosen the set screws of the vertical ribbon feed shaft spur gears and move the gears out of engagement with their respective ribbon spool shaft spur gears. Then position the ribbon spool shaft spur gears by means of their set screws. When tightening the set screws make certain that they bear against the flat faces on the shafts.

16. VERTICAL RIBBON FEED SHAFT SPUR GEARS (Figure 8)

Both right and left vertical ribbon feed shaft

spur gears should line up with their respective ribbon spool shaft spur gears. To adjust, position the vertical ribbon feed shaft spur gears by means of their set screws making sure that the set screws bear against the flat faces on the shafts.

17. RIBBON SPOOL CUPS (Figure 9) See Note (D) on Page 1-3

The centers of the ribbon rollers should be 3/4" to 7/8" in front of a line through the centers of the ribbon spool shafts. There should be no bind between the ribbon spool shaft spur gears and the vertical ribbon feed shaft spur gears at any point in their engagement. To adjust, position each ribbon spool cup by means of the nut on its ribbon spool cup bushing. When tightening the nut, take up the play between the ribbon spool cup bushing and the bracket in a direction to make the play between the spur gears a maximum. (See Figure 8 for location of parts).

18. VERTICAL RIBBON FEED SHAFT SPRING TENSION (Figure 9)

Move the ribbon feed shaft to the right, thus disengaging its gear from the gear on the left vertical feed shaft. Hook an 8 oz. scale onto the pin on the left ribbon spool shaft and pull in a horizontal direction. It should require 2 to 4-1/2 ozs. (1-1/2 to 2-1/2 ozs. for 100 W.P.M.) to start the shaft turning. Move the ribbon feed shaft to the left and in the same manner check the spring tension of the right vertical ribbon feed shaft. To adjust, position the collars on the vertical feed shafts (Figure 8), by means of their set screws to obtain the proper tension.

19. RIBBON REVERSE ARMS RIBBON GUIDE SLOT (Figure 10)

The ribbon guide slot should be .025" to .035" wide and the straight upright piece should clear the angled arm by .010" to .020". To adjust, bend the upright ends of the ribbon reverse arms.

20. RIBBON REVERSE SHAFTS (Figure 10) See Note (A) on Page 1-3

There should be .040" to .060" clearance between the bottoms of the ribbon spool cups and the upper ends of the ribbon reverse shafts when the ribbon reverse arms are held up against the ribbon spool brackets.

a. See Note (C) on Page 1-3 . To adjust typing units so equipped, loosen the set screw of the left

ribbon reverse arm, and if necessary, the set screws of the collars and the link of the left ribbon reverse shaft. Position the shaft while holding the ribbon reverse arm up against the ribbon spool bracket and then tighten the ribbon reverse arm set screw. Adjust the right ribbon reverse shaft in the same manner.

b. See Note (D) on Page 1-3 . To adjust typing units so equipped, loosen the set screw of the spring block on the left ribbon reverse shaft, and, if necessary, the set screws of the ribbon reverse shaft collar and link. Position the shaft while holding the ribbon reverse arm against the ribbon spool bracket and the spring block up against the reverse arm. Then tighten the spring block set screw. Adjust the right ribbon reverse shaft in the same manner.

21. RIBBON REVERSE SHAFTS COLLARS (Figure 10) See Note (D) On Page 1-3

The ribbon reverse shafts should have from .002" to .010" end play. To adjust, position the collars by means of their set screws, while holding both ribbon reverse arms forward against their stops. Rotate the collars simultaneously so that the set screws are approximately centrally located between the ribbon spool brackets and the casting; gage by eye. Check to see that there is sufficient clearance between the set screws and both the ribbon spool brackets and the casting, when the ribbon reverse arms are against their extreme stops.

22. RIBBON REVERSE SHAFTS LINKS (Figure 11) See Note (A) On Page 1-3

The ribbon reverse bail should clear both left and right ribbon reverse pawls by .015" to .050" when the pull bar bail is in its extreme rear position and both the left and right ribbon reverse arms are held forward against their stops. When checking the .015" clearance between either ribbon reverse pawl and the ribbon reverse bail, the play in the ribbon reverse bail should be taken up in a direction to make the clearance a minimum. When checking for the .050" clearance, the play in the ribbon reverse bail should be taken up in a direction to make the clearance a maximum. To adjust, position the ribbon reverse shafts links by means of their set screws. At the same time, make certain that the ribbon reverse pawl links do not bind at their shoulder screws and that the right ribbon reverse shaft link clamping screw does not interfere with the screw which anchors the ribbon feed ratchet friction spring to the carriage casting.

23. RIBBON SPOOL CUPS AND RIBBON REVERSE ARM BACKSTOP (Figure 10B) - See Note (C) On Page 1-3

The centers of the ribbon rollers should be $3/4$ " to $7/8$ " in front of a line through the centers of the ribbon spool shafts (Figure 9). With the ribbon reverse arms held against their backstops (Figure 10B), approximately $3/4$ of the tooth on each ribbon reverse pawl should be in a position to be engaged by the ribbon reverse bail. There should be no bind between the ribbon spool shaft spur gears and the vertical ribbon feed shaft spur gears at any point in their engagement. To adjust, position the ribbon spool cups and ribbon reverse arm backstops by means of the nuts on the ribbon spool cup bushings. When tightening the nuts, take up the play between the ribbon spool cup bushings and the ribbon spool brackets in a direction to make the play between the spur gears a maximum.

24. RIBBON REVERSE ARM YIELD SPRING TENSION (Figure 10B) - See Note (C) On Page 1-3

Position the ribbon reverse bail so that it will block the full travel of the ribbon reverse arm, and with the ribbon reverse pawl resting against the ribbon reverse bail, apply the push end of an 8 oz. scale, held at a right angle to the ribbon reverse arm at the center where the ribbon is threaded. It should require 1- $1/2$ to 4- $1/2$ ozs. to start the ribbon reverse arm moving. To increase or decrease the tension, remove the spring and adjust by bending.

25. RIBBON REVERSE PAWL SPRING TENSION (Figure 11) - See Note (A) On Page 1-3

With the ribbon feed shaft in its left position and the pull bar bail in its extreme forward position, hold the carriage so that the ribbon spool cups are lowermost. Then hook an 8 oz. scale in the notch of the left reverse pawl and pull horizontally toward the rear of the carriage. It should require 1 to 2 ozs. to start the pawl moving. Move the ribbon feed shaft to its right position and, in the same manner, check the tension of the right ribbon reverse pawl spring.

26. RIBBON REVERSE BAIL SPRING COMPRESSION (Figure 11) - See Note (A) On Page 1-3

With the type bar carriage held so that the ribbon spool cups are lowermost, and the pull bar bail plunger is in its extreme forward

position, hook a 4 lb. scale in the corner at the left end of the ribbon reverse bail and pull horizontally toward the front of the carriage. It should require 2 to 4 lbs. to just start the ribbon reverse bail moving. Measure the right spring compression at the right end of the ribbon reverse bail moving. Measure the right spring compression at the right end of the ribbon reverse bail for this requirement in the same manner.

27. TYPE BAR BACKSTOP (RIGID TYPE) (Figure 12A) - See Note (A) On Page 1-3

With the pull bar bail in its extreme rear position, there should be not less than .010" clearance between the type bar backstop and the pull bars when the type bars are held in the type bar guide. Make this check on the two end pull bars and the middle pull bar. To adjust, set the up and down position of the type bar backstop by means of its elongated mounting holes to meet this requirement.

NOTE

When meeting the clearance requirement between the backstop and the pull bars, the backstop should be positioned low enough to eliminate any interference between adjacent type bar assemblies at the pallet ends which would be likely to cause "light" printing. It is preferable that the end type bars rest against the backstop buffer strip along its entire width. It is permissible, however, to allow a clearance of not more than .010" between the front edge of the buffer strip and the type bars.

28. TYPE BAR BACKSTOP (FLOATING TYPE) (Figure 12B) - See Note (A) On Page 1-3

With the play of the backstop taken up toward the left, the right end of the backstop should overlap the outside end of the formed projection of the supporting spring by $1/64$ " to $1/16$ " as gauged by eye. If necessary, form the right hand spring by bending, keeping the projection in a horizontal plane. Check and adjust the left hand bracket in a similar manner with the play of the backstop taken up toward the right.

With the pull bar bail in its extreme rear position and with the backstop located at the approximate center, with regard to its side play, position the type bar backstop brackets upward or downward by means of the elongated holes, so that the following requirements are met.

Preliminary: The end type bars should rest against the backstop along its entire width within .010".

Preliminary: With the type bars held in the guide against the platen, there should be at least .015" clearance between the backstop and the pull bars.

NOTE

This clearance should be kept towards the minimum side to prevent interference between adjacent type pallets.

With the play of the backstop taken up to the left, raise the type bars and hold them against the platen. There should be at least .010" clearance between the undersurface of the backstop and the closest pull bar. Make this check with the left end type bar and with the center type bar. Repeat this check with the right end and center type bars when the play in the backstop is taken up to the right.

29. RIBBON SHIFT LEVER BRACKET (Figures 13 and 14) - See Note (A) On Page 1-3

The ribbon oscillator lever should move freely in its slot when its spring is unhooked and the ribbon carrier is approximately centrally located with respect to the type bar guide. To adjust, position the ribbon shift lever bracket by means of its enlarged mounting holes. Replace the ribbon oscillator lever spring.

30. RIBBON OSCILLATOR LEVER SPRING TORSION (Figure 13) - See Note (A) On Page 1-3

With the ribbon shift lever spring removed, hook an 8 oz. scale over the lower end of the ribbon oscillator lever and pull horizontally toward the rear of the type bar carriage. It should require 2-1/2 to 3-1/2 ozs. to start the oscillator lever moving. Replace the ribbon shift lever spring.

31. RIBBON SHIFT LEVER SPRING TENSION (Figure 13) - See Note (A) On Page 1-3

With the ribbon oscillator lever spring unhooked from the oscillator lever, apply the push end of a 12 lb. scale, held in a vertical position, to the ribbon shift lever at the place where the ribbon oscillator lever spring is mounted. It should require 1 to 1-3/4 lbs. to start the shift lever moving. Replace the ribbon oscillator lever spring.

32. MARGIN BELL PAWL SPRING TENSION (Figure 14) - See Note (A) On Page 1-3

Hook an 8 oz. scale, held in a horizontal position, over the margin bell pawl, just above the stop, and pull in line with the spring. It should require 1/2 to 1-1/2 ozs. to start the pawl moving.

33. RIBBON LOCKOUT BAR DETENT SPRING PRESSURE (Figure 15)

NOTE

This adjustment applies only to those printers equipped with the standard (non-adjustable) ribbon lockout bar.

With the ribbon oscillator extension held clear of the ribbon lockout bar and the lockout bar pushed inward, hook a 32 oz. scale over the end of the lockout bar and pull directly in line with the bar. It should require 16 to 32 ozs. to pull the lockout bar out to its unoperated position.

34. RIBBON LOCKOUT BAR DETENT SPRING PRESSURE (Figure 16)

NOTE

This adjustment applies only to those printers equipped with the adjustable ribbon lockout bar.

With the ribbon lockout bar in its unoperated position (extreme right) and with the push end of a 12 lb. scale bearing against the ribbon lockout bar and pushing directly in line with the bar, it should require 1-1/4 to 6-1/2 lbs. to disengage the ribbon lockout bar detent spring from its notch in the lockout bar.

REPLACE THE BELL CRANK ASSEMBLY - SEE PARAGRAPH 2.h.

NOTE

The following two adjustments apply only to those printers equipped with a three-section pull bar spring bracket.

35. RIGHT PULL BAR SPRING BRACKET (Figure 18 - Model 15) (Figure 145 - Model 20) - See Note (A) On Page 1-3

With the pull bar bail in its extreme rear position, the right end pull bar and the fourth (Model 15) eighth (Model 20) pull bar from the right end should have some play, not more than .004", between the right spring bracket and the type bar when the type bar is in its guide. To adjust, loosen the mounting screw of the right pull bar spring bracket and position the bracket. Tighten the screw.

NOTE

If the second or third (Model 15) or second through seventh (Model 20) pull bar from the end binds against the spring bracket when their respective type bars are moved to the type bar guide by hand, readjust the spring bracket so that all four (Model 15) eight (Model 20) pull bars are free and so that the end pull bar and at least one of the other three (Model 15) seven (Model 20) pull bars have some play, not more than .004", between the type bars and the spring bracket when their respective type bars are in the type bar guide.

36. LEFT PULL BAR SPRING BRACKET (Figure 18) - See Note (A) On Page 1-3

a. Model 20 typing unit use similar manner as for Right Pull Bar Spring Bracket adjustment above.

b. Model 15 typing unit.

With the pull bar bail in its extreme rear position, the left end pull bar and the third pull bar from the left end should have some play not more than .004", between the left spring bracket and the type bar when the type bar is in the type bar guide. To adjust, loosen the mounting screw of the left pull bar spring bracket and position the bracket. Tighten the screw.

NOTE

If the second pull bar from the left end binds against the bracket, readjust the spring bracket so that the end pull bar and the second pull bar from the left end have some play, not more than .004", between the left spring bracket and the type bar when the type bar is in the type bar guide.

37. MARGIN ADJUSTING SCREW ARM SPRING PRESSURE (Figure 19) - See Note (A) On Page 1-3

With the notch in the right margin adjusting screw arm engaged with the detent spring, hook a 12-lb. scale over the adjusting screw and pull at right angles to the arm toward the rear of the type bar carriage. It should require 2 to 7 lbs. to disengage the arm from the detent spring.

38. CARRIAGE SUPPORT AND PULL BAR BAIL PLUNGER ROLLERS - See Note (A) On Page 1-3

The three carriage support rollers and the pull bar bail plunger roller should turn freely with a barely perceptible amount of end play. To adjust,

loosen the lock nuts and position the cone nuts. The rollers should turn freely with a barely perceptible amount of end play after the lock nuts are tightened. (See Figure 22 for location of parts.)

REST THE TYPING UNIT ON ITS RIGHT SIDE

39. MAIN SHAFT

When the main shaft is rotated, the selector cams on the selector cam sleeve should line up with their respective selector levers. To adjust, loosen the four screws which hold the main shaft bearing caps and position the main shaft. Then tighten the bearing caps mounting screws.

40. MAIN SHAFT JAW CLUTCH THROWOUT LEVER (Figure 20)

With the motor operating, open and close the signal line and then stop the motor. There should be from .010" to .020" clearance between the teeth of the two clutch members. Adjust the clutch throw-out lever by means of its pilot screws to obtain this clearance. After adjusting, the lever should be free, with not more than .002" end play.

41. MAIN SHAFT JAW CLUTCH THROWOUT LEVER SPRING TENSION

Place the typing unit on its left side and rotate the main shaft until the clutch teeth are fully engaged. Hook an 8 oz. scale, held in a horizontal position, over the clutch throwout lever at the spring hole, and pull at right angles to the throwout lever. It should require 2-1/2 to 4 ozs. to start the lever moving. (See Figure 20 for location of parts.)

42. MAIN SHAFT JAW CLUTCH SPRING TENSION (Figure 21)

Place the typing unit on its right side. Rotate the main shaft until the low part of the printing bail cam is toward the bottom of the printer. With the teeth of the clutch driven member resting against the teeth of the driving member, but not engaged, hook a 32 or 64 oz. scale on the driven member in line with the low part of the printing bail cam and pull vertically downward. The tension required to separate the clutch teeth is as follows:

22 to 30 ounces for 60 wpm operation
32 to 42 ounces for 75 wpm operation
46 to 58 ounces for 100 wpm operation

NOTE

After checking the 22 to 30 ounce pull and with the clutch teeth still separated, gradually reduce the tension exerted by the scale on the driven clutch member. The clutch teeth should come to rest against each other, but not engaged, before the scale reading drops to 10 ounces.

43. SPACING SHAFT LOWER BEARING BRACKET (Figure 22)

NOTE

In order to facilitate rotating the spacing shaft gear hold the spacing escapement pawl away from the ratchet (Figure 57).

There should be a minimum amount of play without binding at any point of engagement between the spacing shaft gear and the main shaft spacing gear during one complete revolution of the spacing shaft gear. To adjust, place the typing unit in its normal upright position; unhook the carriage return operating lever spring from the spring post; move the eccentric away from the bearing bracket and position the bracket by means of its elongated mounting holes. Replace the carriage return operating lever spring and reposition the eccentric against the bearing bracket.

44. PRINTING BAIL SHAFT RIGHT BEARING

With the printing bail held toward the right, there should be some, not more than .015" clearance between the end of the printing bail casting and the left bearing of the printing bail shaft. To adjust, remove the printing bail spring and position the right bearing by utilizing its elongated mounting holes. Replace the printing bail springs.

REPLACE THE TYPE BAR CARRIAGE -
SEE PARAGRAPH 2.i.

45. PRINTING BAIL (Figure 23)

The pull bars should clear the code bars .010" to .050" when the main shaft is rotated until the printing bail is in its extreme rear position.

Check this adjustment with the type bar carriage in both its extreme right and left positions and with the play in the pull bars taken up in a direction to make the clearance a minimum. To adjust, position the printing bail by means of its adjusting screw and lock nut, located on the printing bail operating arm.

NOTE

If the clearance at one side is so unequal to the clearance at the other side that the .010" to .050" clearance cannot be obtained, it will be necessary to refine the PULL BAR GUIDE paragraph 9 (Figure 4) in such a way that the clearance between the pull bar bail and the pull bar humps, at the side that had the least clearance, is reduced to a minimum and, at the side that had the most clearance, is increased to a maximum for the PRINTING BAIL.

On units equipped with floating backstops, the clearance between the code bars and any pull bars should be at least .010" when the printing bail is in its rearmost (stop) position and when the play in the type bar backstop is taken up towards the left and towards the right. If necessary, refine, the TYPE BAR BACKSTOP requirements paragraph 28. Check this requirement with the type bar carriage in its extreme right and left positions and with the play of the pull bars taken up in a direction to minimize the clearance.

NOTE

The following two adjustments apply only to printers equipped with a two-piece function lever bail assembly.

46. FUNCTION LEVER BAIL (Figures 24 and 25) - See Note (A) On Page 1-3

There should be .040" to .060" clearance between the rear edge of the No. 1 (Model 15) or No. 0 (Model 20) vane and the front edges of the function levers, except the universal function lever, when the main shaft is rotated until the printing bail is in its rearmost position and the No. 1 (Model 15) or No. 0 (Model 20) vane is held midway between its marking and spacing positions. To adjust, position the function lever bail by means of its elongated mounting holes.

47. BLOCKING PLATE (Figure 24) - See Note (A) On Page 1-3

The position of the blocking plate should be as follows:

a. With the CARRIAGE RETURN combination selected, the line feed push bar (Figure 51B) removed, and the main shaft rotated until the carriage return function lever is drawn completely into selection with the vanes, the travel of the function lever bail should be blocked by

the selected function lever and the front edge of the right projection of the function lever bail should be flush (within .005") with the top front edge of the rear prong of the carriage return function lever. (See Figure 25 for location of parts.)

b. With the LINE FEED combination selected, the line feed pushbar (Figure 51B) removed, and the main shaft rotated until the line feed function lever is drawn completely into selection with the vanes, the travel of the function lever bail should be blocked by the selected function lever and the front edge of the left projection of the function lever bail should be flush (within .005") with the top front edge of the rear prong of the line feed function lever. (See Figure 25 for location of parts.)

To adjust, position the blocking plate by means of its slotted holes. Replace the line feed push bar.

48. FUNCTION LEVER BAIL - ONE PIECE
(Figure 25) - See Note (A) On Page 1-3

On typing units equipped with the one piece function lever bail, the position of the bail should be as follows:

a. With the CARRIAGE RETURN combination selected, the line feed push bar (Figure 51B) removed, and the main shaft rotated until the carriage return function lever is drawn completely into selection with the vanes, the travel of the function lever bail should be blocked by the selected function lever and the front edge of the right projection of the function lever bail should be flush (within .005") with the top front edge of the rear prong of the carriage return function lever.

b. With the LINE FEED combination selected, the line feed push bar (Figure 51B) removed, the main shaft rotated until the line feed function lever is drawn completely into selection with the vanes, the travel of the function lever bail should be blocked by the selected function lever and the front edge of the left projection of the function lever bail should be flush (within .005") with the top front edge of the rear prong of the line feed function lever.

c. There should be .040" to .060" clearance between the rear edge of No. 1 (Model 15) or No. 0 (Model 20) vane and the front edge of the function levers, except the universal function lever, when, with the line feed push bar (Figure 51B) removed, the main shaft is rotated until the printing bail is

in its extreme rear position and the No. 1 (Model 15) or No. 0 (Model 20) vane is held midway between its MARKING and SPACING positions.

To adjust, loosen the function lever bail mounting screw nuts. Move the function lever bail to its rearmost position and tighten the mounting screw nuts. Then select the CARRIAGE RETURN combination and reposition the right end of the function lever bail to meet the requirements specified in paragraph a. Next select the LINE FEED combination and adjust the left end of the function lever bail to meet the requirements specified in paragraph b. Finally, rotate the main shaft until the printing bail is in its extreme rear position and check for the requirements specified in paragraph c. If this latter requirement is not met, it will be necessary to add or remove shims between the function lever bail and its mounting brackets and readjust both ends of the bail. Replace the line feed push bar.

49. SIXTH VANE EXTENSION SPRING COMPRESSION (Figure 26) - See Notes (A), (I) On Pages 1-3, 1-4

On typing units equipped with the new style sixth vane extension, (a formed piece of steel mounted on the sixth vane by means of shoulder screws and compression springs), measure the compression of the springs as follows:

Back off the left pilot screw (Figure 25) and remove the sixth vane from the typing unit. With the vane held in a horizontal position and with the vane extension extending upward, hook an 8 oz. scale over the upper end of the extension. Pulling at right angles and toward the front of the vane, it should require 3/4 to 1-1/4 ozs. to start the extension moving away from the vane. Check this spring compression in the opposite direction by hooking the scale over the end of the extension and pulling toward the rear edge of the vane. Replace the sixth vane.

50. SIXTH VANE (Figure 25) - See Notes (A), (I) On Pages 1-3, 1-4

With the platen in the LETTERS position, there should be .008" to .030" clearance between the right edge of the sixth vane extension and the right end of the slot in the unshift push bar. The vane should have some end play, not more than .004". To adjust, loosen the vane clamping screws and position the sixth vane by means of its pilot screws. Tighten the clamping screws.

NOTE

When checking the .008" to .030" clearance, the forward edge of the sixth vane should be held in its lowermost position but not with sufficient pressure to spring or bend the parts involved.

51. SELECTOR VANES (Figure 25) - See Note (A) On Page 1-3

The forked arm of each vane should line up with its respective T lever. When the printing bail is in its extreme rear position, each vane should have some end play, not more than .004". To adjust, loosen the vane clamping screws and position the vanes by means of their pilot screws. Tighten the clamping screws.

52. FUNCTION BAIL SPRING TENSION (Figure 27) - See Note (A) On Page 1-3

With the function bail in its extreme rear position, unhook the function bail spring from the front spring post and hook a 4 lb. scale in the spring eye. It should require 2 to 3 lbs. to extend the spring to its position length.

53. PRINTING BAIL SPRING TENSION (Figure 28) - See Note (A) On Page 1-3

Rotate the main shaft until the printing bail is in its extreme rear position. Hook a 12 lb. scale over the left end of the adjusting lever, directly behind the spring notch in the lever, and pull in line with the spring. It should require 6-1/2 to 8-1/2 lbs. for 60 or 75 wpm operation, and 4 to 6 lbs. for 100 wpm operation, to start the lever moving. To adjust, position the spring adjusting lever screw.

REPLACE THE TYPE BAR CARRIAGE -
SEE PARAGRAPH 2.i.

NOTE

The following sixteen adjustments apply only to printers equipped with pulling magnet selectors.

PLACE THE TYPING UNIT ON ITS RIGHT
SIDE

54. SELECTOR ARMATURE BRACKET LINK FRICTION (Figure 29)

Remove the selector armature bracket link screw. With an 8 oz. scale hooked in the link

screw hole and pulled at right angles to the link, it should require some tension, not over 8 ozs., to start the link moving. If necessary, remove the link and adjust the slotted end to obtain this friction. Replace the link and screw.

55. SELECTOR LEVER SPRING (Figure 29)

With the code bars in the MARKING position and the main bail in its extreme forward position, move the swords manually to the SPACING position. Hook a 32 oz. scale over the end of each selector lever at the selector cam sleeve and pull radially to the main shaft. It should require 6 to 10 ozs. to start each selector lever moving.

NOTE

When checking the tension of the selector lever springs, make sure that the selector levers are free and without bind.

56. SELECTOR SEPARATOR PLATE (Figure 30)

NOTE

The separator plate leaf springs are adjusted during the initial assembly of the unit and should require attention only if the selector has been damaged or dismantled. If it is found necessary to check the adjustment, extreme care should be exercised in the removal and replacement of the selector lever springs to guard against distorting them. The subsequent selector adjustments will be facilitated if the swords and selector levers are replaced in the identical location they formerly occupied.

The leaf springs should exert a light pressure against the swords. To adjust, bend the leaf springs at the narrow portions so that the ends of the springs are .050" to .060" below the under surface of the straight portions.

57. SELECTOR ARMATURE (Figure 31)

The armature should be free on its pivot screws, with barely perceptible end play. There should be some clearance, not more than .008", between the lower surface of the armature locking wedge and the No. 1 (Model 15) No. 0 (Model 20) sword under the following conditions:

a. No. 1 (Model 15) No. 0 (Model 20) selector lever resting on the peak of its cam.

b. No. 1 (Model 15) No. 0 (Model 20) sword held against the upper separator plate without bending the latter.

c. Armature end play taken up in a direction to reduce the specified clearance to a minimum.

To adjust, proceed as follows: If there is no clearance between the armature locking wedge and the No. 1 (Model 15) No. 0 (Model 20) sword, loosen the lock nut on the upper pivot screw and adjust to obtain clearance, noting that a quarter-turn of the screw is equivalent to approximately .006". Remove the armature bracket and adjust the lower pivot screw to obtain the proper armature end play. Replace the armature bracket.

If there is more than .008" clearance, remove the armature bracket and adjust the lower pivot screw. Replace the bracket and adjust the armature end play by means of the upper pivot screw.

58. SELECTOR ARMATURE BRACKET LINK (Figure 32 and 33) - See Note (E) On Page 1-4

The position of the armature bracket should be such that a line through the center of the No. 1 (Model 15) No. 0 (Model 20) sword extends approximately through the centers of the armature pivot screws when the swords are held midway between the stop posts by means of the No. 72581 gauge pins. To adjust, proceed as follows:

a. Unhook the locking lever spring; loosen the magnet bracket mounting screws, and move the bracket to its rearmost position. Loosen the armature bracket mounting screws, the link screw, and back off the armature stops. Move the bracket eccentric out of the way so that it will not interfere with the adjustment. Rotate the main shaft until the No. 1 (Model 15) No. 0 (Model 20) selector lever rests on the peak of its cam.

b. Hold the swords in a position midway between the two stop posts by means of the gauge pins inserted between the stop posts and the swords. Be sure that both the armature extension arms are between the arms of the swords. With the swords held in this position, place the No. 73370 locating gauge over the end of the No. 1 (Model 15) No. 0 (Model 20) sword, so that the two legs of the gauge are against the ends of the sword arms. Move the bracket to a position where both armature extension arms are against the flat surface between the legs of the gauge.

c. Hold the bracket in this position and tighten the link screw only. Remove the locating gauge and the two gauge pins.

59. SELECTOR ARMATURE BRACKET (Figure 33) - See Note (E) On Page 1-4

a. The position of the armature bracket should be such as to provide some clearance, not more than .040", between each sword and either stop post under the following conditions:

(1) Rotate the main shaft until the No. 1 (Model 15) No. 0 (Model 20) selector lever is resting on the peak of its cam. With the armature in its unoperated (SPACING) position, move the spacing arm of the No. 1 (Model 15) No. 0 (Model 20) sword against the armature extension.

(2) Place a .040" wire gauge against the spacing stop post and rotate the armature slowly toward the MARKING position. The blade of the sword should strike the .040" gauge before the armature leaves the spacing arm of the sword. Under these conditions, the armature will move the sword to not more than .040" of the stop post. Remove the .040" gauge and repeat the above procedure. The armature should leave the spacing arm of the sword before the blade of the sword strikes the spacing stop post. Under these conditions, there will be some clearance between the sword and the stop post.

b. Unhook the armature spring at its adjusting screw and with the selector armature in its operated (MARKING) position, move the marking arm of the No. 1 (Model 15) No. 0 (Model 20) sword against the selector armature extension. Then rotate the armature slowly toward the SPACING position until the armature just leaves the marking arm of the No. 1 (Model 15) No. 0 (Model 20) sword. Check the clearance between the No. 1 (Model 15) No. 0 (Model 20) sword and the marking stop post in the same manner as described in the foregoing.

c. With each selector lever on the peak of its cam, each associated sword should be tried for the foregoing requirement of some clearance, not more than .040", between each sword and the stop posts. To adjust, tighten the armature bracket mounting screws just enough so that the bracket may be moved by tapping it lightly. By rotating the bracket on its pivot, the clearance between the sword and the stop posts may be regulated. If this clearance is more than .040", move the bracket in a direction to bring the armature toward the sword. If there is no clearance, move the bracket in the opposite direction to bring the armature away from the sword.

d. If the clearance between the sword and one stop post is close to zero and the clearance

between the sword and the other stop post is more than .040", it will be necessary to refine the 'SELECTOR ARMATURE BRACKET LINK' as follows:

(1) Loosen the armature bracket mounting screws and the armature bracket link screw and move the armature bracket to the right or left so that the rear end of the link will move in the direction corresponding to the post at which a greater clearance is desired; i.e., if the clearance between the sword and the right stop post is less than that between the sword and the left stop post, move the bracket to the right. Tighten the bracket link screw and proceed to adjust the armature bracket according to the preceding paragraph.

e. After the bracket is set and both screws are tightened, move the bracket eccentric against the bracket and tighten the screw. The eccentric and bracket link will, therefore, determine the position of the bracket. The bracket may be removed by simply removing the two bracket screws. In replacing, the bracket should be held against the eccentric stop, while the two bracket screws are tightened.

60. ARMATURE STOPS (Figures 33 and 34) -
See Note (E) On Page 1-4

a. Model 15 Printer.

The No. 1 sword arms (right and left) should clear the associated arms of the selector armature extension .035" to .037" when the front edge of the opposite sword arm is against its armature extension arm and the No. 1 selector lever is on the high part of its cam. To adjust the clearance of the right arm, remove the locking lever spring and reposition the unoperated stop screw with the armature in its unoperated position. To adjust the clearance of the left arm, reposition the operated stop nut with the armature in its operated position. If necessary, pinch the nut to make it tight on its screw. Recheck the right arm and replace the locking lever spring.

NOTE

The upper limit may be increased up to .042" only if necessary to meet the requirements given under "ARMATURE TRIP-OFF ECCENTRIC SCREW".

b. Model 20 Printer.

(1) The following adjustment applies to printers equipped with or without the armature

detent or armature stop plate and operated at a speed less than 318 operations per minute.

NOTE

If the printer is equipped with an armature stop plate, the stop plate should be positioned so that it is ineffective before making this adjustment.

The No. 0 sword arms (right and left) should clear the associated arms of the selector armature extension .040" to .042" when the front edge of the opposite sword arm is against its armature extension arm and the No. 0 selector lever is on the high part of its cam. To adjust the clearance of the right arm, reposition the armature stop screw with the armature in its unoperated position. To adjust the clearance of the left arm, reposition the armature stop nut with the armature in its operated position. If necessary, pinch the nut to make it tight on its screws. Recheck the right arm and replace the locking lever spring.

(2) The following adjustment applies to printers not equipped with the armature detent but equipped with the armature stop plate and operated at speeds greater than 318 operations per minute.

NOTE

Before making this adjustment, back off the armature stop screw and nut so that they are ineffective.

Turn the main shaft until the No. 0 selector lever is on the peak of its cam. With the spacing arm of the No. 0 sword against the spacing side of the armature extension, there should be a clearance of .056" to .058" between the side of the armature extension and the No. 0 sword on the marking side (See Figure 146A). Now place the armature and sword in the marking position. There should be a clearance of .030" to .034" between the side of the armature extension and the No. 0 sword on the spacing side (See Figure 146B). To adjust, loosen the armature stop plate mounting screws and position the stop plate. Tighten the mounting screws.

61. ARMATURE LOCKING WEDGE (Figure 35)-
See Note (E) On Page 1-4

There should be .006" to .012" clearance between the point of the armature locking wedge and

the point of the locking lever when the locking lever is on the long high part of the locking cam and the two points are inline. To adjust, position the locking wedge forward or backward in its slot in the armature extension by means of the locking wedge lock nut.

NOTE

When making this adjustment on typing units equipped with a mechanical motor stop mechanism, set the motor stop pawl latch so that the shoulder of the latch is against the front face of the armature extension. (See Figure 30).

62. ARMATURE LOCKING LEVER SPRING TENSION (Figure 35) - See Note (E) On Page 1-4

With the locking lever on the high part of the locking cam, hook a 32 oz. scale in the spring hole of the locking lever and pull inline with the spring. It should require 10 to 14 ozs. to start the lever moving.

NOTE

On Model 15 units equipped with a mechanical motor stop mechanism, perform the following adjustments at this time.

- (1) Motor Stop Lever Bracket - Paragraph 240.
- (2) Motor Stop Lever Eccentric - Paragraph 241.
- (3) Motor Stop Lever Backstop Screw - Paragraph 242.
- (4) Motor Stop Pawl Backstop - Paragraph 243.
- (5) Motor Stop Release Lever Eccentric - Paragraph 244.
- (6) Motor Stop Pawl Spring Compression - Paragraph 245.
- (7) Motor Stop Lever Spring Tension - Paragraph 246.
- (8) Motor Stop Contact Lever Spring Tension - Paragraph 247.
- (9) Motor Stop Function Lever Spring Tension - Paragraph 248.

63. STOP LEVER ECCENTRIC SCREW (Figure 36) - See Note (E) On Page 1-4

The stop lever on the range finder assembly should overtravel the latching surface of the trip latch by some clearance, not more than .006". To adjust, position the stop lever eccentric screw by means of its lock nut, making certain

that, when tightening the nut, the adjustment is not disturbed.

64. STOP LEVER SPRING TENSION (Figure 37) - See Note (E) On Page 1-4

NOTE

Be sure that the STOP LEVER ECCENTRIC SCREW has been adjusted before checking this requirement.

With the trip latch plunger held operated, hook an 8 oz. scale at the end of the stop lever on the range finder assembly. It should require 3/4 to 1-1/4 ozs. to start the lever moving.

65. TRIP LATCH SPRING COMPRESSION (Figure 36) - See Note (E) On Page 1-4

When measuring this requirement, the range finder assembly should be held in a horizontal position. Apply the push end of an 8 oz. scale, held in a vertical position, to the trip latch as near to the stop lever as possible and push upward. It should require 1 to 1-1/2 ozs. to start the trip latch moving. Replace the range finder assembly, taking care to avoid jamming the trip latch plunger against the armature trip-off screw when remounting. (See Figure 38).

66. SELECTOR STOP ARM AND STOP LEVER ENGAGEMENT (Figure 38)

With the selector magnet armature in the spacing position, rotate the selector cam sleeve until the stop arm moves the stop lever to its maximum travel beyond the step of the trip latch. Loosen the range finder assembly mounting screws and the positioning link mounting screw just enough to make them friction tight. Position the range finder assembly so that the overtravel of the stop lever beyond the trip latch is at least half but not more than the width of the stop lever. This should be checked with the range indicator set at 0, 60, and 120 on the range scale. Tighten the mounting screws and the positioning link screws.

REPLACE THE RANGE FINDER ASSEMBLY

67. ARMATURE TRIP-OFF ECCENTRIC SCREW (Figure 39)

a. There should be some clearance, not more than .004" between the stop lever and the trip latch when the armature is in the unoperated position and the selector cam sleeve is rotated

until the stopping edge of the stop lever is directly below the latching surface of the trip latch. While checking the above clearance, take up the play in the stop lever with a screwdriver applied axially adjacent to the spring hole as close to the bearing as possible with thrust in the direction of the trip latch. This clearance should be held to a minimum to favor the "at least .002" end play of the trip plunger.

b. The trip latch plunger should have at least .002" end play when the armature is held in the attracted position and when the stop lever is resting against its eccentric stop post. To adjust, loosen the trip-off eccentric screw lock nut and position the eccentric screw to meet the first requirement. The latter requirement serves as a check on the TRIP-OFF ECCENTRIC SCREW and on the ARMATURE STOPS.

68. SELECTOR MAGNET COIL

The left edge of the core of the left magnet coil should align within 1/64" of the left edge of the armature. Adjust by means of the magnet coil mounting screws. (See Figure 33 for location of parts.)

69. MAGNET BRACKET (Figure 33).

There should be .002" to .007" clearance (.003" to .010" for chromium plated armatures) between each magnet core and the armature anti-freeze strip when the magnet coils are energized and the armature is against the marking stop nut. The faces of the cores should be parallel to the face of the armature. To adjust, position the bracket by means of its enlarged mounting holes.

NOTE

The following twenty adjustments apply only to Model 15 printers equipped with holding magnet selectors.

70. SELECTOR SEPARATOR PLATE (See paragraph 56)

71. ARMATURE PIVOT SCREW (Figure 40) - See Note (E) On Page 1-4

With the armature lever spring and the selector arm spring unhooked, the armature lever should be free on its pivots with barely perceptible end play. Adjust by means of the upper pivot screw.

72. SELECTOR CORE AND ARMATURE ALIGNMENT (Figure 41) - See Note (E) On Page 1-4

a. PRELIMINARY

When the armature is in its operated position, it should touch both magnet pole faces approximately at their centers, and the cores should be located equi-distant, with respect to the outer edge of the armature as gauged by eye when a light reflector such as a piece of white paper is held behind the magnet. To adjust, remove the selector magnet bracket from the typing unit and reposition the magnet core assembly with its mounting screws loosened while holding the assembly so that the cores are vertical and the armature, by its own weight, rests against the pole faces. Tighten the magnet core assembly mounting screws and replace the selector magnet bracket.

b. FINAL

With the armature lever spring and the selector arm spring in position (hooked), manually rotate the shaft and selector cam sleeve so that the armature lever slowly moves the armature toward the magnet core. Observe that the armature touches both core ends simultaneously and approximately in the center of curvature; gauge by eye, holding a light reflector such as a piece of white paper behind the magnet and armature assembly. Adjust by repositioning the magnet core by means of its elongated mounting holes and mounting screws. Tighten the screws.

NOTE 1

When the cores are in proper adjustment, it should require at least 3-1/2 pounds pull, with a 64 ounce scale applied at right angle to the armature edge in line with the armature lever, to separate the armature from the cores when a current of .020 amperes is flowing through the magnet coils (coils in series shunted by a 5000 ohm resistor).

NOTE 2

The adjustment may have to be modified in order to obtain the required receiving margins and to prevent slow release of the armature due to oil-seal. The margin requirement and the minimum magnetic pull requirement of 3-1/2 pounds should be considered as "Final Check" for the armature and core alignment.

73. SELECTOR ARM PIVOT SCREW (Figure 42) - See Note (E) On Page 1-4

With the armature lever spring, the selector arm spring, and selector arm stopdetent spring unhooked, the selector arm should be free on its pivots with barely perceptible end play, and the locking lever should overtravel the top and bottom edges of the locking wedge. There should also be a minimum clearance of .008" between the selector arm and the armature lever and a minimum clearance of .010" between the selector arm and the selector arm stop detent when the play in the detent is taken up in a direction to make this clearance a minimum. The end play may be adjusted by means of the left pivot screw. If the minimum clearance requirements are not met, it will be necessary to remove the selector magnet bracket and the selector arm bracket and adjust both pivot screws of the selector arm.

74. SELECTOR ARM BRACKET (Figure 40) - See Note (E) On Page 1-4

a. The position of the selector arm bracket should be such as to provide some clearance, not more than .040", between each sword and either stop post, under the following conditions:

(1) Remove the locking lever spring, the armature lever spring, and the selector arm spring. Rotate the main shaft until the No. 1 selector lever is resting on the peak of its cam. With the selector arm in its unoperated (SPACING) position, move the SPACING arm of the No. 1 sword against the selector arm extension. Then rotate the selector arm slowly toward the MARKING position until the selector arm just leaves the SPACING arm of the No. 1 sword. There should be some clearance, not more than .040", between the No. 1 sword and the SPACING stop post.

(2) With the selector arm in its operated (MARKING) position, move the MARKING arm of the No. 1 sword against the selector arm extension. Then rotate the selector arm slowly toward the SPACING position until the selector arm just leaves the MARKING arm of the No. 1 sword. There should be some clearance, not more than .040", between the No. 1 sword and the MARKING stop post.

b. With each selector lever on the peak of its cam, each associated sword should be tried for the foregoing requirement of some clearance, not more than .040". To adjust, loosen the selector arm bracket mounting screws just

enough to make the bracket friction tight. Then, to equalize the clearance between the swords and the stop posts, loosen the centralizing eccentric screw lock nut and turn the eccentric screw clockwise to provide more clearance on the SPACING side or counterclockwise to provide more clearance on the MARKING side.

NOTE

Be sure that the selector arm stopdetent does not interfere with the adjustment.

c. The centralizing eccentric screw should always be located so that its indicating line is adjacent to the marked scale that has been provided on the bracket to aid in gauging the amount the screw must be turned. Tighten the lock nut when the selector arm has been centralized. To obtain the "some clearance, not more than .040"," requirement between the swords and the stop posts, insert the 90783 adjusting wrench in one of the two holes provided and turn the wrench to move the bracket closer to or farther from the swords as required. Then tighten the selector arm bracket mounting screws. Replace the locking lever spring, selector arm spring, and armature lever spring.

75. LOCKING WEDGE (Figure 43) - See Note (E) On Page 1-4

With the locking lever on a high part of its cam, the front end of the locking wedge should clear the locking lever by .005" to .012" when the end of the wedge is held in line with the locking lever. To adjust, loosen the locking wedge mounting screw and position the locking wedge in its guide; then tighten the mounting screw.

76. LOCKING LEVER SPRING TENSION (Figure 43) - See Note (E) On Page 1-4

With the locking lever on the high part of its cam, hook an 8 oz. scale on the end of the locking lever at the spring hole and pull in line with the spring. It should require 4 to 5-1/2 ozs. for 60 and 75 wpm operation or 7 to 10 ozs. for 100 wpm operation to start the lever moving away from the cam.

77. SELECTOR ARM STOP DETENT (Figure 44) - See Note (E) On Page 1-4

a. With the locking lever on the low part of its cam, there should be an equal amount of clearance, within .003", between the sides of the locking wedge and the locking lever when the selector arm is in the MARKING or SPACING position.

NOTE

When checking the MARKING position, be sure that the selector arm operating screw does not interfere with the movement of the selector arm.

b. To adjust, loosen the screw that mounts the selector arm stop detent eccentric post just enough to make the post friction tight. Position the stop detent by turning the post. Tighten the post mounting screw.

78. SELECTOR ARM STOP DETENT SPRING TENSION (Figure 44) - See Note (E) On Page 1-4

Unhook the stop detent spring from the locking lever guide and hook an 8 oz. scale in the spring eye. It should require 4 to 5 ozs. for 60 and 75 wpm operation or 6-3/4 to 7-3/4 ozs. for 100 wpm operation to pull the spring to its position length.

79. SELECTOR LEVER SPRING TENSION (Figure 43) - See Note (E) On Page 1-4

With the code bars in the MARKING position and the main bail in its extreme forward position, move the swords manually to the SPACING position. Hook a 32 oz. scale over the end of each selector lever at the selector cam sleeve and pull radially to the main shaft. It should require 6 to 10 ozs. to start each selector lever moving.

NOTE

When checking the tension of the selector lever springs, make sure that the selector levers are free and without bind.

80. SELECTOR MAGNET BRACKET POSITION (Figure 45) - See Note (E) On Page 1-4

With the main shaft in the STOP position, rotate the selector cam sleeve until the locking lever just drops off the high part of its cam; then rotate the cam sleeve backward until the rotation is stopped by the locking lever. With the selector arm locked in its MARKING position, there should be a clearance of .060" to .065" between the armature lever and the face of a tooth on the armature lever cam. To adjust, loosen the selector magnet bracket mounting screws and the selector magnet bracket adjusting arm mounting screws just enough to make the bracket and adjusting arm friction tight. Then position the selector magnet bracket by means of the

adjusting arm, using the 90783 adjusting wrench. To do this, insert the adjusting wrench in the hole above the end of the adjusting arm and rotate the wrench. Tighten the bracket and adjusting arm mounting screws.

81. SELECTOR MAGNET BRACKET (Figure 41A and B) - See Note (E) On Page 1-4

NOTE

When making this adjustment the selector arm should be kept in the marking position.

a. With the selector magnet energized, the clearance between the selector arm operating screw and the selector arm should be .004" to .006" greater when the armature lever is on a peak of its cam than when the armature lever is opposite an indent on the cam.

b. To adjust, de-energize the magnet and rotate the selector cam sleeve until the armature lever is resting on a peak of the armature lever cam. Holding the cam sleeve in this position, turn the main shaft to a point where it moves the armature lever the greatest distance.

c. With the selector magnet still de-energized, loosen the selector magnet bracket mounting screws and, by means of its adjusting screw, rotate the selector magnet bracket so that the armature just touches the pole-faces; then turn the adjusting screw an additional one-tenth of a turn counter-clockwise. This will press the armature firmly against the magnet cores. (While making the one-tenth of a turn adjustment, be careful to avoid lost motion due to loose fitting screw threads.)

d. With the selector magnet energized, measure the clearance between the selector arm operating screw and the selector arm and if there is no clearance, back off the selector arm operating screw to provide at least .006" clearance. Then rotate the selector cam sleeve so that the armature lever is opposite an indent of its cam and again measure the clearance between the selector arm operating screw and the selector arm. If the difference in the two clearances exceeds .006", the selector magnet bracket adjusting screw should be turned clockwise. If the difference in the clearance is less than .004", turn the screw counterclockwise. Tighten the selector magnet bracket mounting screws.

82. ARMATURE LEVER SPRING TENSION (Figure 41) - See Note (E) On Page 1-4

a. Unhook the armature lever spring from its spring arm and rotate the main shaft until the armature lever is on a high part of its cam. With a 32 oz. scale hooked in its spring eye, pull the spring to its position length. It should require the following tensions:

(1) If a distortion test set is available, the spring tension should be set at the optimum value within the limits of 13 to 24 ozs.

(2) If no distortion test set is available the spring tension should be 17 to 19 ozs. for 60 and 75 wpm operation or 22 to 26 ozs. for 100 wpm operation. When the coils are connected in parallel without a 1000 ohm shunt, the tension should be 13 to 15 ozs.

b. To adjust, loosen the spring arm mounting nut and position the spring arm. Tighten the mounting nut and rehook the armature lever spring.

83. SELECTOR ARM OPERATING SCREW (Figure 46) - See Note (E) On Page 1-4

With the selector magnet energized and the selector cam sleeve rotated so that the armature lever is opposite an indent of its cam, there should be a clearance of .003" to .006" between the selector arm operating screw and the selector arm. To adjust, loosen the selector arm operating screw lock nut and position the screw; then tighten the lock nut.

84. SELECTOR ARM SPRING TENSION (Figure 47) - See Note (E) On Page 1-4

Unhook the selector arm stop detent spring. With the armature lever on a high part of its cam, and the locking lever held away from the locking wedge, hook an 8 oz scale over the end of the locking wedge and pull parallel to the selector arm spring. It should require 1-1/4 to 1-3/4 ozs. for 60 and 75 W. P. M. operation (1-3/4 to 2-1/4 ozs. for 100 W. P. M. operation) to start the selector arm moving. Reform the outer loop of the selector arm spring, if necessary, to meet this requirement. Rehook the selector arm stop detent spring.

CAUTION

Care should be taken not to nick, crimp, or otherwise deform the spring, or spring wire when reforming the loops.

85. STOP LEVER ECCENTRIC SCREW (Figure 48) - See Note (E) On Page 1-4

The stop lever on the range finder assembly should overtravel the latching face of the trip latch by not more than .006". To adjust, loosen the stop lever eccentric screw lock nut and position the screw; then tighten the nut, making certain that the tightening of the nut does not disturb the adjustment.

86. TRIP LATCH SPRING COMPRESSION (Figure 48) - See Note (E) On Page 1-4

When measuring this requirement, the range finder assembly should be held in a horizontal position. Apply the push end of an 8 oz. scale, held in a vertical position, to the trip latch, as near to the stop lever as possible. It should require 1 to 1-1/2 ozs. for 60 and 75 wpm operation or 2-3/4 to 3-1/4 ozs. for 100 wpm operation, when pushing upward, to start the trip latch moving.

87. STOP LEVER SPRING TENSION (Figure 37) - See Note (E) On Page 1-4

NOTE

Be sure that the stop lever eccentric has been adjusted before checking this requirement.

With the trip latch plunger held operated, hook an 8 oz. scale on the end of the stop lever of the range finder assembly and pull horizontally at right angles to the stop lever. It should require 3/4 to 1-1/4 ozs. to start the lever moving.

REPLACE THE RANGE FINDER ASSEMBLY

88. SELECTOR STOP ARM AND STOP LEVER ENGAGEMENT (Figure 38)

With the selector magnet armature in the spacing position, rotate the selector cam sleeve until the stop arm moves the stop lever to its maximum travel beyond the step of the trip latch. Loosen the range scale assembly mounting screws and the positioning link mounting screw just enough to make them friction tight. Position the range scale assembly so that the overtravel of the stop lever beyond the trip latch is at least half but not more than the width of the stop lever. This should be checked with the range indicator set at 0, 60, and 120 on the range scale. Tighten the mounting screws and the positioning link screw.

89. TRIP-OFF SCREW (Figure 49)

a. There should be some clearance, not more than .004", between the stop lever and the trip latch when the armature is in the unoperated position and the selector cam sleeve is rotated until the stopping edge of the stop lever is directly below the latching surface of the trip latch. While checking the above clearance, take up the play in the lock lever with a screw driver applied axially adjacent to the spring hole as close to the bearing as possible with thrust in the direction of the trip latch. This clearance should be held to a minimum to favor the "at least .002" end play of the trip plunger.

b. The trip latch plunger should have at least .002" end play when the armature is held in the attracted position and when the stop lever is resting against its eccentric stop post.

c. To adjust, loosen the trip-off screw lock nut and position the screw to meet the first requirement. The latter requirement serves as a check on the TRIP-OFF SCREW and on the SELECTOR MAGNET BRACKET.

END OF HOLDING MAGNET SELECTOR
ADJUSTMENTS

89.1 ARMATURE DETENT MOUNTING BRACKET (Figure 147) (For Printers Equipped With Armature Detent)-See Note (J) on Page 1-4

Replace the armature detent spring and remove the armature spring. Depress the trip latch spring so that the trip latch plunger will be away from the armature trip-off eccentric screw. Hook an 8 oz. scale over the armature extension. An equal pull should be required to move the armature detent pin over the armature detent when going to both the marking and spacing positions. To adjust, loosen the detent mounting bracket lock nuts and position the bracket. Tighten the lock nuts and replace the armature spring.

89.2 ARMATURE DETENT SPRING TENSION (Figure 147) (For Printers Equipped With Armature Detent)-See Note (J) on Page 1-4

Unhook the detent spring from the bracket and hook an 8 oz. scale in the spring eye. It should require 3-1/2 to 4-1/2 ozs. to pull the detent spring to its position length. Replace the detent spring.

90. PLATEN UNIT PILOT SCREWS See Note (A) on Page 1-3

The platen unit should be midway between the side frames and should be free on its bearings without end play. To adjust, place the typing unit

in its normal upright position. Disconnect the line feed and shift-unshift vertical link at the upper shoulder screws. (See Figures 50 and 53) Unhook the platen balance spring and the shift-unshift detent spring. Then position the platen unit by means of its pilot screws to meet the first requirement. Then back off one pilot screw until the platen unit has some end play. Turn the pilot screw in just enough to take up the end play. Replace the platen balance spring and shift-unshift detent spring and reconnect the line feed and shift-unshift vertical link. (Care should be taken not to tighten the pilot screws to the extent that they cause a strain on the side frames.)

91. PLATEN SHIFT-UNSHIFT STOP POST-See Note (A) on Page 1-3

The top and bottom surfaces of the platen shift-unshift stop post should be parallel to a line through the center of the platen detent roller screw and the platen pilot screw. To adjust, loosen the platen shift-unshift stop post nut and rotate the post. (See Figure 50 for location of parts.)

91.1 LETTERS AND FIGURES STOP SCREW - See Note (I) on Page 1-4 (Applies to 100 W. P. M. Units)

The "Letters" and "Figures" stop screws shall be adjusted so that the faces of the majority of the "characters" in both the lower and upper positions of the platen conform to the curvature of the platen. The remainder of the pallets must be repositioned by aligning to make their character faces conform to the platen curvature.

NOTE

Slight flattening of faces of characters having less than average area of platen contact, with a strip of aluminum oxide cloth or similar material wrapped around the platen, is permissible.

REPLACE THE TYPE BAR CARRIAGE - SEE PARAGRAPH 2. i

92. UNSHIFT (LETTERS) (Model 15) SHIFT (Model 20) STOP SCREW

With the platen in the UNSHIFT (Model 15) SHIFT (Model 20) position and the letter N type bar held lightly against the platen, the face of the letter N should conform to the curvature of the platen when viewed along the axis of the platen. A further check may be made by inserting a sheet of paper with a carbon in the printer and pressing the letter N firmly against the platen. The impression made on the paper should be of uniform shade. To adjust, raise the UNSHIFT (Model 15) SHIFT (Model 20) stop screw if the shading is

lighter at the bottom of the character and lower it if the shading is lighter at the top. (See Figure 50 for location of parts.)

93. SHIFT (FIGURES) (Model 15) UNSHIFT (Model 20) STOP SCREW

With the platen in the UNSHIFT position (down) for Model 15 or SHIFT position (up) for Model 20, print the letter W on the platen. Then, with the platen in the SHIFT position (up), the figure 2 should be in direct alignment with the letter W when the figure 2 is printed directly on the platen. Adjust by means of the SHIFT (Model 15) UNSHIFT (Model 20) stop screw. (See Figure 50 for location of parts.)

94. SHIFT (FIGURES), UNSHIFT (LETTERS), AND LINE FEED FUNCTION LEVER SPRING TENSIONS (Figure 51) See Note (A) on Page 1-3

Place the typing unit on its right side. Select the BLANK combination and rotate the main shaft until the printing bail is in its extreme forward position. Hood a 32 oz. scale over the rear extension of the SHIFT, UNSHIFT, and line feed function levers just in front of the lobes which engage the push bars and pull horizontally at right angle to the rear extension. It should require 15 to 19 ozs. to start each of these function levers moving. When checking these tensions, the push bars should be held away from the function levers.

95. SPACE FUNCTION LEVER SPRING TENSION (Figure 51)

With the space function lever resting against the vanes, but not selected, hook a 32 oz. scale over the rear extension of the lever, just in front of the lobe, and pull horizontally at right angle to the rear extension. It should require 12 to 16 ozs. to start the space function lever moving. When checking this tension, the UNSHIFT push bar should be held away from the function lever.

96. BLANK PRINTING AND SPACING CUTOUT FUNCTION LEVER SPRING TENSION

NOTE

For Model 15 printers, the following spring tension applies only to printers equipped with a special function lever located in slot 7 in the vane frame to prevent printing and spacing when the BLANK combination is selected.

For Model 20 printers, the following spring tension applies to all function levers, regardless of their location in the typing unit, which block printing and spacing but perform no other function.

Rotate the main shaft until the printing bail is in its extreme rear position. Then unhook the blank printing and spacing cutout function lever spring from the spring plate. Hook a 32 oz. scale in the spring eye. It should require 22 to 30 ozs. to extend the spring to its position length.

97. FUNCTION BAIL BLADE (Figure 52)

NOTE

If the SHIFT-UNSHIFT mechanism has not been adjusted, it will be necessary to loosen the mounting screws of the shift bell crank operating lever bracket and move the bracket to its extreme rear position before proceeding with the "FUNCTION BAIL BLADE" adjustment.

a. With the SHIFT, LINE FEED, AND UNSHIFT function levers (Figure 50) alternately selected and the main shaft rotated until the travel of the function lever bail is blocked by the selected function lever, there should be .004" to .015" clearance between the rear edge of No. 1 vane and the bottom of a notch in the selected function lever. With the unshift on space cutout lever (Figure 50) released from the lower extension of the SPACE function lever, place the platen in the SHIFT position, select the SPACE combination, and rotate the main shaft until the function lever bail roller just leaves the cam surface of the SPACE function lever. Under this condition, there should be .004" to .015" clearance between the rear edge of the No. 1 vane and the bottom of a notch in the SPACE function lever.

b. To adjust, select the SHIFT function lever and adjust the right end of the function bail blade by raising or lowering it by means of its elongated mounting holes to secure the specified clearance between the rear edge of the No. 1 vane and the bottom of a notch in the SHIFT function lever. Then select the LINE FEED function lever and adjust the left end of the function bail blade by raising or lowering it to secure the specified clearance between the rear edge of the No. 1 vane and the bottom of a notch in the LINE FEED function lever. If like requirements are not met when the UNSHIFT and SPACE function levers are selected, it may be necessary to readjust both ends of the function bail blade.

98. UNSHIFT ON SPACE CUTOUT LEVER - See Note (I) On Page 1-4

a. If it is desired that the platen return to the UNSHIFT position when the SPACE combina-

tion is received, the UNSHIFT on space cutout lever should be rotated counterclockwise (as viewed from the bottom of the printer) against its stop. The lock nut should be tightened to hold the cutout lever in this position. (See Figure 97 for location of parts.)

b. If it is desired that the platen should not return to the UNSHIFT position when the SPACE combination is received, the UNSHIFT on space cutout lever should be rotated clockwise (as viewed from the bottom of the printer), so that the hooked end of the cutout lever is to the rear of the SPACE function lever extension and the cutout lever touches the side of the SPACE function lever extension. There should be some clearance, not more than .006" between the rear surface of the SPACE function lever extension and the cutout lever. (See Figure 97.)

c. To adjust, first remove the T lever and attached mechanism (See Figure 98) from its mounting post and loosen the cutout lever eccentric screw nut. Position the cutout lever and the eccentric screw and then tighten the nut. Replace the T lever and attached mechanism.

99. SHIFT AND UNSHIFT

a. With the SHIFT-UNSHIFT detent and platen balance springs removed and the UNSHIFT and SHIFT combinations alternately selected, the SHIFT-UNSHIFT stop post should move to within .010" to .025" of the UNSHIFT stop screw and the SHIFT stop screw respectively, when the main shaft is rotated and the selected push bar is moved to its rearmost position when operated by the function bail blade. The platen should be placed in the SHIFT position (up) before selecting the UNSHIFT combination and in the UNSHIFT position (down) before selecting the SHIFT combination.

b. To adjust, place the shift-unshift link bracket in the middle of the adjustment provided by the elongated mounting holes and tighten the mounting screws. Place the typing unit on its right side and rotate the main shaft until the function bail is in its extreme forward position. Adjust the turnbuckle on the shift-unshift link so as to equalize (within .010") the clearance between the function bail blade and the shoulder on the UNSHIFT (Model 15) SHIFT (Model 20) push bar when the platen is in the FIGURES (Model 15) UNSHIFT (Model 20) position, with the clearance between the function bail blade and the shoulder on the SHIFT (Model 15) UN-

SHIFT (Model 20) push bar when the platen is in the LETTERS (Model 15) SHIFT (Model 20) position. Then select the UNSHIFT and SHIFT combinations alternately and check for the specified clearances between the shift-unshift stop post and the UNSHIFT and SHIFT stop screws. If either of these clearances is greater than .025", move the shift-unshift link bracket toward the front of the unit; if less than .010", move it toward the rear, after which a slight readjustment of the shift-unshift link turnbuckle may be necessary to bring both clearances within the specified limits. Replace the shift-unshift detent spring and platen balance spring. (See Figures 50 and 51 for location of parts.)

100. PLATEN BALANCE SPRING TENSION (Figure 53)

With the platen in the UNSHIFT position, unhook the platen balance spring from the platen unit bracket and hook a 12 lb. scale in the spring eye. It should require 3-1/2 to 5 lbs. to pull the spring to position length on units equipped with cast iron platen brackets, and 1-1/4 to 2 lbs. on units equipped with aluminum platen brackets. Replace the spring.

101. SHIFT-UNSHIFT DETENT

When the platen is shifted to the SHIFT and UNSHIFT positions, the platen detent roller should ride equally on either side of the detent. To adjust, position the shift-unshift detent by means of its eccentric shoulder screw. (See Figure 50 for location of parts.)

102. SHIFT-UNSHIFT DETENT SPRING TENSION (Figure 50)

Hook a 25 lb. scale over the extension on the shift-unshift detent and pull in line with the spring. It should require from 10 to 14 lbs. to start the detent moving.

103. SIXTH VANE EXTENSION - See Note (I) On Page 1-4

NOTE

This adjustment applies only to printers equipped with the old style sixth vane extension (a flat spring formed from spring steel).

Unhook the sixth vane detent spring from the spring plate. When the platen is shifted to the SHIFT and UNSHIFT positions, the sixth vane should travel equally on either side of the detent in the W notch of the locking function lever. Adjust by bending the sixth vane extension. After bending the extension, the UNSHIFT push bar should not bind on the extension in either the UNSHIFT or SHIFT positions. (See Figure 25 for location of parts.)

104. UNSHIFT AND SHIFT PUSH BARS SPRING TENSIONS (Figure 51A)

Select any character and rotate the main shaft until the printing bail is in its extreme forward position. Place the push end of an 8 oz. scale directly beneath the notch on the push bar and push horizontally at right angle to the bar. It should require 3 to 5 ozs. to start the push bar moving.

105. PLATEN SHAFT

The platen shaft should have some end play, not more than .004". To adjust, position the friction assembly on the platen shaft by means of its set screws. (See Figure 64B for location of parts.)

106. SINGLE-DOUBLE LINE FEED DETENT

When the single-double line feed lever is shifted to the SINGLE and DOUBLE line feed positions, the hump on the detent spring should travel equally on either side of the detent. (See Figure 50 for location of parts.) To adjust, position the detent by means of its mounting screw.

107. SINGLE-DOUBLE LINE FEED DETENT SPRING PRESSURE (Figure 50)

With the single-double line feed lever in the SINGLE line feed position (up), hook a 4 lb. scale, held in a horizontal position, over the extension of the lever and pull toward the front. It should require 1-1/4 to 4 lbs. to move the lever to the DOUBLE line feed position.

108. LINE FEED DETENT LEVER

With the single-double line feed lever in the SINGLE line feed position (up), and the line feed bail operated by hand, the line feed pawl, when sliding off the rear edge of the single-double line feed lever, should just miss the edge of a tooth on the ratchet. (See Figure 50 for location of parts.) To adjust, loosen the detent lever

eccentric screw nut (Figure 53) and turn the eccentric screw so as to rotate the platen by means of the detent lever. Tighten the detent lever eccentric screw nut and check the adjustment for all the teeth on the line feed ratchet. For line feed ratchets and detents marked with an "X", see that the holes adjacent to the "X" line up.

NOTE

There are two positions of the detent lever eccentric screw which will provide correct adjustment. Use the position which applies the least tension to the detent lever spring and be sure that the detent roller rests in the bottom of a notch on the detent ratchet.

109. LINE FEED LINK TURNBUCKLE (Figure 50)

a. With the single-double line feed lever in the SINGLE line feed position, select the LINE FEED combination and rotate the main shaft as follows:

(1) Until the line feed push bar is being stripped from the function bail blade on printers not equipped with the automatic carriage return and line feed.

(2) Until the function bail is in its extreme rear position on printers equipped with the automatic (Model 15) combined (Model 20) carriage return and line feed.

b. Under this condition, the turnbuckle should be adjusted so that the platen has rotated one line-space, that the detent roller rests in the hollow between two ratchet teeth and that the feed pawl is still in engagement with a ratchet tooth to such an extent that there is no clearance or not more than .002" clearance between the detent roller and the detenting face of the tooth just above the roller. Check for this condition at 4 positions on the ratchet approximately 90° apart.

110. LINE FEED PUSH BAR SPRING TENSION

With the typing unit on its right side and the printing bail in its extreme rear position, apply the push end of an 8 oz. scale to the line feed push bar just to the rear of the function lever extension and push horizontally at right angles to the bar (See Figure 51A). It should require 1-1/2 to 2-1/2 ozs. to start the push bar moving.

111. LINE FEED DETENT LEVER SPRING TENSION

a. Model 15 (Figure 53)

With the typing unit in its normal upright position, hook a 12 lb. scale over the head of the line feed lever detent roller mounting screw and pull at right angle to the detent lever. It should require 5 to 6 lbs. to start the detent lever moving.

b. Model 20 (Figure 148)

With the typing unit resting in its normal upright position, hook a 4 lb. scale over the end of the detent lever and pull in line with the spring. It should require 2-1/2 to 3-1/2 lbs. to start the detent lever moving.

112. LINE FEED PAWL SPRING TENSION (Figure 50)

With the single-double line feed lever in the DOUBLE line feed position and the line feed pawl in its unoperated position, hook an 8 oz. scale under the line feed pawl just to the rear of the notch and pull up vertically. It should require 2 to 4 ozs. to start the pawl moving.

113. LINE FEED CHECK SCREW (Figure 53, Model 15) (Figure 148, Model 20)

The line feed check screw should drop in the twelfth (Model 15) or fifteenth (Model 20) notch from the detent roller when line feed ratchets having 33 teeth are used, and in the fourteenth (Model 15) or seventeenth (Model 20) notch when ratchets having 37 teeth are used. (When counting the notches, start with the notch just above the detent roller.) There should be some clearance, not more than .020", between the front face of the screw and the face of the tooth at the point of minimum clearance, when the check screw is held in the bottom of a notch on the ratchet. To adjust, loosen the line feed check screw lock nut and position the check screw to meet the foregoing requirements. Tighten the lock nut. Rotate the platen roll and check the clearance in each notch of the ratchet. If necessary, loosen the clamping nut of the line feed check post stop screw and back off the stop screw before making this adjustment.

114. LINE FEED CHECK POST STOP SCREW (Figure 53)

With the line feed check post stop screw held down against the casting, there should be .015"

to .030" clearance between the line feed check screw and each tooth on the detent ratchet, when the platen is rotated. To adjust, loosen the check post clamping nut and position the stop screw. Before tightening the clamping nut, make sure that the line feed check post is against the inner side of the casting and that the end of the line feed check lever shaft (Figure 50) is flush with the outer surface of the casting. Tighten the clamping nut.

115. LINE FEED CHECK LEVER (Figure 53)

With the LINE FEED combination selected and the main shaft rotated until the line feed pawl has reached its farthest travel in rotating the platen, the line feed pawl lever should be in contact with the check lever, and there should be some clearance, not more than .015", between the lower edge of the line feed check screw and the bottom of any notch in the detent ratchet. To adjust, loosen the check lever set screw and position the check lever. (See Figure 50 for location of parts.) Before tightening the set screw see that the shaft has some end play, not more than .008".

NOTE

When checking the clearance between the check screw and the ratchet, the play of the line feed check lever shaft in its right bearing should be taken up to make this clearance a maximum.

116. LINE FEED CHECK LEVER SPRING TENSION (Figure 50)

With the line feed pawl in the forward position, hook an 8 oz. scale under the head of the check lever set screw and pull at right angle to the set screw. It should require 2 to 3 ozs. to start the lever moving.

117. PRESSURE ROLLER RELEASE SHAFT COLLARS (Figure 54) - See Note (F) On Page 1-4

The pressure roller release shaft should have some end play, not more than .004". With the right collar against the casting, there should be 5/32" to 7/32" clearance between the boss just to the rear of the platen shaft boss and the pressure roller release shaft arm when the arm is opposite the boss. Adjust the clearance of the release shaft arm by means of the right locating collar and adjust the end play by means of the left locating collar.

118. PRESSURE ROLLER RELEASE CAMS
(Figure 55) - See Note (F) On Page 1-4

a. On units equipped with six pressure rollers, the following applies. With the pressure roller release shaft arm in its rear position, the camming surfaces should line up with the release levers. With all the travel of the front pressure rollers taken up manually in a downward direction, (so that the rear pressure rollers are resting against the platen), there should be at least .060" between the front pressure rollers and the platen. With all the travel of the rear pressure rollers taken up manually in a downward direction, (so that the front pressure rollers are resting against the platen), there should be at least .060" between the rear pressure rollers and the platen. To adjust, position the cams on the release shaft by means of their set screws.

b. On units equipped with one pressure roller, the following applies. With the pressure roller release shaft arm in its rear position, the pressure roller should be from .015" to .050" away from the platen. To adjust position the cams on the release shaft by means of their set screws.

119. PRESSURE ROLLER SPRING TENSION
(Figure 55) - See Note (F) On Page 1-4

With the release shaft arm in its forward position, hook a 12 lb. scale over the lower end of the spring adjusting lever, just above the spring, and pull in line with the spring. It should require 5 to 6 lbs. to start the adjusting lever moving. Adjust by means of the spring adjusting lever screw.

120. PRESSURE ROLLER RELEASE LEVER SHAFTS

a. Model 15 Typing Unit

With the inner surfaces of the two paper chute mounting extensions touching the outer bosses of the two release lever shafts, the left end of the left release lever shaft (viewed from the rear of the printer) should project beyond the outer surfaces of the left paper chute mounting extension and butt against the platen bracket. The outer end of the right release lever shaft should project beyond the outer surface of the right paper chute extension by not more than 3/64" to 3/32". To adjust, position the release shafts by means of their set screws. (See Figure 54 for location of parts.)

b. Model 20 Typing Unit

With the inner surface of the paper chute mounting extensions against the casting, the outer ends of the release lever shafts should project beyond the outer surfaces of the paper chute mounting extensions by not more than 1/32". (See Figure 149 for location of parts.) To adjust, position the release lever shafts by means of their set screws.

121. PAPER CHUTE SPRING TENSION (Figure 56B) - See Note (F) On Page 1-4

With the pressure roller release shaft arm in its rear position, hook an 8 oz. scale over the rear edge of the paper chute, midway between the side frames, and pull at right angles to the rear flat surface. It should require 2 to 7 ozs. to start the paper chute moving.

122. PAPER CHUTE (See Notes (F), (I) On Page 1-4

With one side of the paper chute touching its associated end boss on the platen cross bar, the other side of the chute should touch or be within .004" of touching its associated end boss; also, when one or both sides of the paper chute are touching their associated end bosses on the platen cross bar, there should be some clearance, not more than .020", between the front edge of the paper chute and the surface of the platen. To adjust, bend the chute manually to meet the above requirements. (Rotate the platen shaft to see that the paper chute does not bind the platen.)

123. PAPER FINGERS (Figure 56B) - See Note (F) On Page 1-4

The paper finger shaft stop arm should clear its stop post .004" to .020" with both paper fingers resting against the platen. When paper 8-1/2" wide is used, the outer edge of the lower portion of each finger should be within 3/32" of the end of the rubber portion of the platen and should not extend beyond the end of the rubber portion. When paper narrower than 8-1/2" is used, the left finger should be moved inward correspondingly. To adjust, first set the lateral position of the right paper finger and secure it to the shaft by means of its set screw with the specified clearance between the stop arm and the stop post. Then set the left paper finger to correspond to the width of the paper.

124. PAPER FINGERS SHAFT SPRING TENSION (Figure 56B) - See Note (F) On Page 1-4

Hook a 32 oz. scale over the paper finger shaft stop arm, just above the stop post, and pull in line with the spring. It should require 16 to 22 ozs. to start the stop arm moving.

125. PAPER STRAIGHTENER ROD STOPS (Figure 56B) - See Note (F) On Page 1-4

When the paper straightener rod is in its extreme upward position, there should be a clearance of .030" to .050" between the straightener rod and the blocking edge of the stops. To adjust, position the stops by means of their elongated holes.

126. PAPER STRAIGHTENER ROD SPRING TENSION (Figure 56B) - See Note (F) On Page 1-4

Hook a 32 oz. scale over the ends of the paper straightener rod levers, where the springs are hooked, and pull in line with the springs. It should require 8 to 12 ozs. to start the levers moving.

127. PAPER GUIDES (Figure 56A) - See Note (F) On Page 1-4

The outer sides of both paper guides should be .040" to .050" from the shoulder on their respective ends of the straightener rod. To adjust, position the guides on the shaft by means of their set screws.

128. SPACING ESCAPEMENT PAWL OPERATING ARM (Figure 57)

With the LINE FEED combination selected and the main shaft rotated until the function lever bail rests on the line feed function lever, there should be .020" to .040" clearance between the rear spacing escapement pawl and the low part of the spacing escapement ratchet. To adjust, loosen the spacing escapement pawl operating arm mounting screws and position the arm. Tighten the mounting screws.

NOTE

On units equipped with a horizontal tabulator mechanism having the adjustable front spacing escapement pawl, perform the following adjustment at this time. (1) Front Spacing Escapement Pawl - Paragraph 278.

129. SPACING ESCAPEMENT PAWL SPRING TENSION (Figure 57)

Rotate the main shaft until the printing bail is in its extreme rear position. Hook a 32 oz. scale under the front spacing escapement pawl at the place where it rests against the escapement pawl operating arm, and pull vertically upward. It should require 10 to 14 ozs. to start the pawl moving.

130. MARGIN BELL HAMMER (Figure 58)

With the bell hammer arm resting against the stop post, there should be .020" to .060" clearance between the bell and the bell hammer. To adjust, loosen the margin bell hammer bracket mounting screws and shift the bracket; if this does not give the required clearance, then bend the bell hammer arm along its entire length, avoiding a sharp bend at any point.

131. MARGIN BELL HAMMER SPRING TENSION (Figure 58)

Hook a 32 oz. scale over the bell hammer arm, directly below the spring, and pull in line with the spring. It should require 10-1/2 to 13-1/2 ozs. to start the arm moving.

132. SIGNAL BELL HAMMER SPRING TENSION (Figure 59A)

With the bell latch bar in its latched position, hook an 8 oz. scale over the upper end of the bell hammer arm extension and pull at right angles to the inner straight edge of the extension. It should require 3 to 5 ozs. to start the bell hammer moving.

133. SIGNAL BELL LATCH BAR LATCH SHIMS (Figure 59A)

a. Set the typing unit on its right side. (1) For Model 15 Typing Unit, with the platen in the UN-SHIFT position (down), the BELL combination selected, (2) For Model 20 Typing Unit, select the letter "J" combinations, rotate the main shaft until the printing bail is in its extreme forward position, there should be .004" to .010" clearance between the bell latch bar and the lobe on the rear extension of the bell function lever. When checking this clearance, the front shoulder of the bell latch bar should be fully latched on its latch.

NOTE

On Model 15 typing units which ring the bell on BLANK, set up the letter T combination and rotate the main shaft until the printing bail is in its extreme forward position.

b. To adjust, add or remove shims between the latch and the function lever comb.

134. SIGNAL BELL LATCH BAR LATCH (Figure 59A)

With the main shaft rotated until the function bail is in its extreme rear position, there should be a clearance of .010" to .020" between the front shoulder of the bell latch bar and its latch. When checking this clearance, the shoulder on the bell reset bar should be fully engaged with the function bail blade. To adjust, position the bell latch bar latch toward the front or rear by means of its elongated mounting holes.

135. SIGNAL BELL HAMMER BACKSTOP (Figure 59A)

With the bell latch bar in its latched position, there should be .020" to .040" clearance between the bell hammer arm extension and the bell operating lever. To adjust, position the bell hammer backstop by means of its elongated mounting holes.

136. SIGNAL BELL OPERATING LEVER SPRING TENSION (Figure 59A)

Remove the bell reset bar spring. With the rear shoulder of the bell latch bar resting against the bell latch bar latch, hook a 4 lb. scale under the head of the bell operating lever screw and pull parallel to the latch bar. It should require 1-1/4 to 2-1/4 lbs. to start the lever moving. Replace the bell reset bar spring.

137. SIGNAL BELL RESET BAR SPRING TENSION (Figure 59B)

Rotate the main shaft until the function bail is in its extreme forward position. With the front shoulder of the bell latch bar resting against the latch, hook an 8 oz. scale over the bell reset bar just in front of the shoulder and pull at right angles to the reset bar. It should require 3 to 5 ozs. to start the reset bar moving.

138. BELL FUNCTION LEVER SPRING TENSION (Figure 59A)

Select any character and rotate the main shaft until the bell function lever rests against the

vaner but is not selected. Hook a 4 lb. scale over the rear extension of the bell function lever just in front of the lobe that engaged the bell latch bar, and pull at right angles to the lever. It should require 1-3/4 to 2-1/4 lbs. to start the lever moving.

139. CARRIAGE RETURN LATCH BAR LATCH SHIMS

With the letter O combination selected and the main shaft rotated until the printing bail is in its extreme forward position, there should be .004" to .010" clearance between the carriage return latch bar and the lobe on the rear extension of the carriage return function lever. When checking this clearance, the shoulder on the carriage return latch bar should be fully latched on the latch. (Similar to "Bell Latch Bar Latch Shims Adjustment" Figure 59A.) To adjust, add or remove shims between the carriage return latch bar latch and the function lever comb. (See figure 60 for location of parts.)

140. CARRIAGE RETURN LATCH BAR LATCH

With the main shaft rotated until the function bail is in its extreme rear position, there should be .010" to .020" clearance between the shoulder on the carriage return latch bar and the latch. When checking this clearance, the shoulder on the carriage return reset bar should be fully engaged with the function bail blade. (Similar to "Bell Latch Bar Latch Adjustment" Figure 59A.) To adjust, position the latch to the front or rear by means of its elongated mounting holes. (See Figure 60 for location of parts.)

141. CARRIAGE RETURN LOCK BAR LATCH ECCENTRIC SCREW (Figure 60B)

With the front end of the dashpot lever held in its extreme left position, there should be .006" to .020" clearance between the lower edge of the lock bar. When checking this clearance, all the play between the lock bar and the shoulder stud should be taken up in a direction to make this clearance a minimum. Adjust by means of the lock bar latch eccentric screw.

NOTE

There are two positions of the eccentric screw at which the proper adjustment can be obtained. Use the position which gives the greater tension to the latch spring.

142. CARRIAGE RETURN LOCK BAR LATCH SPRING TENSION (Figure 60B)

With the carriage return lock bar latch unlatched (resting on the upper part of the carriage return lock bar), hook a 32 oz. scale over the latch just below the spring and pull parallel to the lock bar. It should require 7 to 10 ozs. to start the latch moving.

143. CARRIAGE RETURN LOCK BAR (Figure 60A)

With the carriage return lock bar in its latched position and the shoulder of the lock bar held against the edge of the latch, there should be a clearance of .010" to .020" between the teeth of the carriage return clutch members. Adjust the length of the lock bar by means of its sliding joint to obtain this clearance.

NOTE

Before making the foregoing adjustment, place the typing unit on its back. Rotate the spacing shaft until the mounting screw of the carriage return clutch driven member is accessible. Operate the dash-pot lever to engage the clutch teeth. Loosen the mounting screw and rotate the spacing gear in a clockwise direction (as viewed from the lower end of the shaft) until all the play between the clutch driven member and its mounting screw has been taken up. Tighten the mounting screw.

144. CARRIAGE RETURN OPERATING LEVER STOP SCREW (Figure 60B)

With the typing unit in its normal upright position, select the "CARRIAGE RETURN" combination and rotate the main shaft until the carriage return function lever just trips the carriage return latch bar off its latch. There should be from .002" to .020" clearance between the lock bar shoulder and the inner edge of the lock bar latching lever. When making this adjustment all the play in the mechanism should be taken up in a direction to make the clearance a minimum. This can best be done by applying the hook end of an 8 oz. scale on the lock bar and by pulling and holding the lock bar outward with a tension of 6 ounces. To adjust, set the height of the carriage return operating lever stop screw.

145. CARRIAGE RETURN RESET BAR SPRING TENSION (Figure 60A)

With the typing unit resting on its right side,

the function bail in its extreme forward position, and the carriage return latch bar tripped off its latch, hook an 8 oz. scale over the reset bar just in front of the shoulder and pull horizontally at right angles to the reset bar. It should require 3 to 5 ozs. to start the reset bar moving.

146. CARRIAGE RETURN FUNCTION LEVER SPRING TENSION (Figure 60A) for units not equipped with combined or automatic CR-LF mechanism.

With any character selected and the main shaft rotated until the carriage return function lever is resting against the vanes but not selected, hook a 4 lb. scale over the rear extension of the function lever just in front of the lobe that engages the latch bar, and pull at right angles to the lever. It should require 1-3/4 to 2-1/4 lbs. to start the lever moving.

147. CARRIAGE RETURN OPERATING LEVER SPRING TENSION (Figure 60A)

With the shoulder of the carriage return latch bar against its latch, and the carriage return operating lever spring unhooked from the spring post, hook a 12 lb. scale in the spring eye. It should require 5 to 7 lbs. to extend the spring to position length.

148. CARRIAGE RETURN CLUTCH SPRING COMPRESSION

With the shoulder of the carriage return latch bar resting against its latch and the carriage return lock bar latch held away from the lock bar, apply a 12 lb. push scale to the end of the carriage return clutch fork to which the latch link is assembled and push downward as nearly in line with the latch link as possible. It should require 1-1/2 to 2-1/2 lbs. to start the driving clutch member moving away from the driven member. (See Figure 60 for location of parts.)

NOTE

On units equipped with the automatic carriage return and line feed mechanism, perform the following adjustments at this time.

- (1) Carriage Return Latch Bar Latch Shims - Paragraph 291.
- (2) Carriage Return Function Lever Eccentric Screw - Paragraph 292.
- (3) Operating Bail Line Feed Extension - Paragraph 293.

- (4) Automatic Carriage Return and Line Feed Function Lever Eccentric Screw - Paragraph 294.
- (5) Mounting Bracket - Paragraph 295.
- (6) Trigger Guide - Paragraph 296.
- (7) Trigger Adjustable Screw - Paragraph 297.
- (8) Carriage Return and Automatic Carriage Return and Line Feed Function Levers Spring Tensions - Paragraph 298.
- (9) Trigger Spring Tension - Paragraph 299.
- (10) Bell Crank Retainer Yield Lever Spring Tension - Paragraph 300.

149. DASHPOT LEVER SPRING TENSION

Unhook the dashpot lever spring from the spring post in the dashpot lever and hook a 32 oz. scale in the spring eye. With the front end of the dashpot lever in its extreme right position, it should require 16 to 22 ozs. to extend the spring to its position length.

150. SPACING STOP LEVER BRACKET (Figure 61)

The lower end of the spacing stop lever should clear the driving disc of the main shaft .060" to .080". With the spacing stop lever held against the stop on the bracket by means of its spring, there should be a clearance of .040" to .080" between the lower left edge of the stop lever and the right side of a tooth on the spacing stop sleeve when the tooth is opposite the lever. Adjust the spacing stop lever bracket vertically by means of its enlarged mounting holes to meet the first requirement and adjust it horizontally to meet the latter requirement.

PLACE THE TYPING UNIT IN AN UPRIGHT POSITION

151. SPACING STOP LEVER SPRING TENSION (Figure 61)

With a 32 oz. scale held in a horizontal position and hooked over the upper end of the spacing stop lever, pull toward the right. It should require 8 to 12 ozs. to start the lever moving.

REPLACE THE TYPE BAR CARRIAGE

152. CARRIAGE GUIDE SCREWS (Figure 23)

With the type bar carriage in position on the typing unit and the printing bail in its extreme

rear position, there should be some clearance, not more than .008", between the upper surface of the guide screw heads and the upper surface of the groove in the front carriage track. Check for this clearance over the entire travel of the carriage. Adjust by means of the guide screws and lock nuts.

153. CODE BAR BELL CRANKS

a. The code bars should be carried firmly against their stops in both the MARKING and SPACING positions when the all marking and all spacing combinations are alternately selected and the main shaft is rotated until the function levers are lifted free from the rear edges of the vanes. With the all marking combination selected, move the vanes, one by one, from the marking position to the spacing position and allow them to return to the marking position slowly. Note any of the code bars which are not carried firmly against their stops. (See Figure 62 for location of parts.)

b. Set up the BLANK or all spacing combination on the selector and repeat the foregoing procedure. Again note any of the code bars which are not carried firmly against their spacing stops. If it is found that all the code bars are carried against their stops in the spacing position and not in the marking position, or vice versa, it will be necessary to loosen the mounting screws and adjust the position of the bell crank mounting plate (up and down). If the plate is moved upward, the code bars may be caused to move farther toward the left, which is their marking position. If, however, it is found that only one or two of the code bars fail to be carried firmly against their stops in both the marking and spacing positions, the travel of the code bars may be adjusted by means of the bell crank eccentric bushings.

c. When the bell crank assembly is finally adjusted, all code bars should rest firmly against the marking and spacing stops when the vanes are in their respective marking and spacing positions. Make sure that the upper ends of the bell cranks do not engage the code bars deeply enough to bind.

154. SPACING RACK (Figure 63)

There should be some backlash, not more than .006" between the spacing gear and the spacing rack along the entire travel of the rack. To adjust, remove the type bar carriage draw

strap, loosen the spacing rack mounting screws and position the rack toward the front or rear. Adjust for this backlash with the carriage in its extreme left and right hand positions and also in its center position. Tighten the mounting screws and replace the draw strap.

155. LOCKING FUNCTION LEVER SPRING TENSION (Figure 27)

Rotate the main shaft until the printing bail is in its extreme rear position. Unhook the locking function lever spring from the spring plate and hold the locking function lever against its pivoting shaft. With a 64 oz. scale hooked in the locking function lever spring eye, it should require 40 to 50 ozs. to pull the spring to position length.

156. SIXTH VANE DETENT SPRING TENSION (Figure 25) - See Note (I) On Page 1-4

Hook an 8 oz. scale in the sixth vane detent spring hole and pull in line with the spring toward the rear of the typing unit. It should require 6 to 8 ozs. to start the roller moving away from the sixth vane.

157. CARRIAGE RETURN SPRING DRUM

Rotate the main shaft until the printing bail is in its extreme rear position. Hook a 12 lb. scale over the lower part of the right ribbon spool bracket and pull in a line parallel to the carriage track. It should require 3-3/4 to 4-1/4 lbs. to start the carriage moving away from the extreme left position. When measuring this tension, the carriage return lock bar should be held in approximately its latched position so as to disengage the clutch teeth, and the dashpot lever should be held in its operated position. To adjust, wind up the carriage return spring by rotating the center shaft of the drum to increase the tension, and operate the carriage return drum escapement lever to decrease the tension.

158. PAPER SPINDLE DRAG SPRING (Figure 64A) - See Note (F) On Page 1-4

Insert a paper spindle (without paper) in its bearing slots, and lock it in place with the retaining plates. With both ends of the spindle shaft at the bottom of their slots, apply the push end of a 12 lb. scale to the left end of the spindle shaft and push toward the right side of the typing unit. It should require 5 to 8 lbs. to start the spindle moving. This pressure may be adjusted by bending the spindle drag spring.

159. PLATEN FRICTION ASSEMBLY (Figure 64B) - See Note (F) On Page 1-4

Move the pressure roller release shaft arm (Figure 55) to its extreme rear position. Unhook the line feed detent lever spring (Figure 53) and place the platen crank vertically upward. Hook an 8 oz. scale at the end of the crank handle and pull horizontally toward the front of the typing unit. It should require 5 to 9 ozs. to start the platen rotating. Replace the detent lever spring. This tension may be regulated by means of the adjusting nuts on the friction assembly.

NOTE

On units equipped with a handwheel in place of the platen crank, position the handwheel so that the 1/8 inch diameter hole is located vertically above the platen shaft. Hook the spring scale in the hole and pull horizontally toward the front of the typing unit. Under these conditions the above requirements must be met.

160. SEND-RECEIVE T LEVER FRICTION WASHER (Figure 65A) - See Note (G) On Page 1-4

With the printing bail in its extreme rear position, move the T lever so as to provide .040" to .060" clearance between the T lever and the universal function lever extension. Hook an 8 oz. scale under the right extension of the T lever, just to the left of the universal function lever extension, and pull vertically upward. It should require 5 to 6-1/2 ozs. to start the lever moving. To adjust, replace the friction washer with a new one.

NOTE

On units equipped with the send-receive break mechanism operating on a double blank signal, the friction requirement of 5 to 6-1/2 ozs. may be obtained by adjusting the position of the stop nut when the send-receive "T" lever is equipped with the 119925 elastic stop nut and 71047 shim in place of the 3598 nut and 2191 lock washer previously furnished.

161. UNIVERSAL FUNCTION LEVER SPRING TENSION (Figure 65A) - See Note (G) On Page 1-4

With the printing bail in the extreme rear position, hook a 32 oz. scale under the extreme

front end of the universal function lever extension and pull vertically upward. It should require 14 to 17 ozs. to start the lever moving.

162. BLANK FUNCTION LEVER SPRING TENSION (Figure 65A) - See Note (G) On Page 1-4

a. Model 15 Typing Unit

With the printing bail in its extreme rear position, hook a 12 lb. scale under the extreme front end of the blank function lever extension and pull vertically upward. It should require 4-1/2 to 6 lbs. to start the lever moving.

b. Model 20 Typing Unit

With the printing bail in its extreme rear position, hook a 32 oz. scale over the upper end of the blank function lever and pull horizontally toward the rear of the unit. It should require 10-1/2 to 15-1/2 ozs. to just start the lever moving.

163. SEND-RECEIVE MECHANISM PLATE (Figure 66)

With the left arm of the T lever in contact with the blank function lever extension, there should be some clearance, not more than .008", between the right arm of the T lever and the universal function lever extension when the BLANK or all spacing combination is selected and the main shaft rotated until the blank function lever is completely selected, stopping rotation at the point where the function lever bail roller just leaves the cam surface of the blank function lever. (On typing units equipped with blank printing-spacing cutout function lever, it will be necessary to stop rotation of the main shaft at the point where the function lever bail comes to rest on top of the blank printing-spacing cutout function lever.) To adjust, position the send-receive mechanism plate by means of its elongated mounting holes. When making this adjustment, the intermediate lever should be clear of the blank function lever extension.

NOTE

On typing units where the blank and universal function levers are omitted, the send-receive mechanism plate should be adjusted so as to provide .020" to .030" vertical clearance between both bends of the function lever spring plate and the send-receive mechanism plate.

NOTE

On Model 15 units equipped with a mechanical motor stop mechanism, perform the following adjustments at this time.

- (1) Right Motor Stop Contact - Paragraph 249.
- (2) Left Motor Stop Contact - Paragraph 250.

NOTE

On Model 15 units equipped with a mechanical motor stop mechanism to operate on SHIFT-BLANK-STOP, perform the following adjustments at the times indicated.

- (1) Adapter Plate - Paragraph 253 - at this time.
- (2) Trigger Guide - Paragraph 254 - at this time.
- (3) Blocking Lever Spring - Paragraph 255 - after Send-Receive Reset Lever Upper Adjusting Screw - Paragraph 167.

164. INTERMEDIATE LEVER STOP BRACKET (Figure 66) - See Note (G) On Page 1-4

First select the BLANK combination and rotate the main shaft until the intermediate lever toe is under the blank function lever extension. Make sure that the intermediate lever is approximately vertical. Then select the T combination and rotate the main shaft until the printing bail is in its extreme forward position. During this latter operation the left end of the intermediate lever toe should move to a point at least 1/16" to the right of the blank function lever extension. To adjust, position the intermediate lever stop bracket by means of its elongated mounting holes.

165. INTERMEDIATE LEVER SPRING TENSION (Figure 65A) - See Note (G) On Page 1-4

With the printing bail in its extreme rear position, move the T lever so that its right end is in contact with the universal function lever extension and hold the reset lever so that its upper edge is horizontal. Then hook an 8 oz. scale over the intermediate lever just above the spring arm and pull horizontally toward the left of the typing unit. It should require 3/4 to 1-1/2 ozs. to start the lever moving.

166. MOTOR PLATE

a. There should be a barely perceptible amount of backlash between the motor pinion and

the highest point of the main shaft gear. The lateral alignment of the motor pinion and the main shaft gear should be such that the center line of the gear coincides with a vertical line through the center of the hole in the motor pinion.

b. To check for the lateral alignment, place the typing unit on an adjusted base with a motor assembly and tighten the three typing unit thumb screws. With the keyboard removed from the base, face the front of the unit and make a visual check of the alignment. To adjust, remove the typing unit from the base and loosen the four motor mounting screws. Replace the typing unit on the base and shift the motor by taking up the play in its mounting holes until the two lines previously mentioned coincide.

(1) On printers equipped with motors not having elongated mounting holes, there might be insufficient play in the mounting holes to permit proper alignment. In this case, shift the motor as far as the mounting holes will allow in order to obtain the best possible alignment.

(2) On printers equipped with motors having elongated mounting holes, shift the motor until the lines coincide as nearly as it is possible to determine by eye.

See that the edges of the motor base are parallel to the respective edges of the motor plate. Remove the typing unit and tighten the four motor mounting screws.

c. To adjust for the backlash, loosen the rear motor plate mounting screw and the lock nut on the motor plate adjusting screw. Slightly loosen the two front motor plate mounting screws. Place the typing unit on the base and tighten the three thumb screws. Position the motor plate adjusting screw to obtain the specified backlash. Start the motor and carefully reposition the adjusting screw until the gear noise is reduced to a minimum. Tighten the three motor plate mounting screws and the adjusting screw lock nut. Recheck the backlash.

CAUTION

Care should be exercised in adjusting the vertical position of the motor pinion while the motor is running in order to avoid damaging the main shaft gear or reducing the speed of the motor as a result of too close a mesh between the pinion and the gear.

NOTE

On Model 15 units equipped with a mechanical motor stop mechanism, perform the following adjustments at this time.

- (1) Reset Lever Lower Adjusting Screw - Paragraph 251.
- (2) Reset Lever Downstop Screw - Paragraph 252.

167. SEND-RECEIVE RESET LEVER UPPER ADJUSTING SCREW (Figure 65B) - See Note (G) On Page 1-4

With the printing bail in its extreme rear position and the send-receive lever in the SEND position (up), move the toe of the intermediate lever under the blank function lever extension. Then select the T combination and rotate the motor until the intermediate lever is moved to a position where the blank function lever extension overlaps the toe of the intermediate lever by one half the thickness of the blank function lever extension. Under these conditions, there should be .004" to .006" clearance between the upper edge of the intermediate lever toe and the bottom of the blank function lever extension. To adjust, position the reset lever upper adjusting screw.

168. LEFT MARGIN ADJUSTING SCREW (Figure 60B) - See Note (F) On Page 1-4

The left edge of the letter M should print $7/8$ " (plus or minus $1/16$ "") from the left edge of the platen when used as the first character in lines of 72 character length. When lines of 76 character length are required, or when adjusting typing units that print six characters to the inch instead of the standard ten, the left edge of the letter M should print $11/16$ " (plus or minus $1/16$ "") from the left edge of the platen. To adjust, turn the left margin adjusting screw inward and lock the carriage in place by operating the dashpot lever so that the carriage will be in a position to print the letter M the required distance from the left edge of the platen as specified in the foregoing. Make sure that the carriage clutch members are fully engaged. Then reposition the adjusting screw so that, when the lock nut is slightly tightened so as to take up the end play in the threads and a horizontal pull of 8 lbs. is exerted on the dashpot lever applied with a 12 lb. scale at right angles to the curved surface $1/32$ " behind the margin and adjusting screw, there is a slight clearance (not more than .002") between the end of the screw and the dashpot lever. Turn the left margin adjusting screw $1/6$ th turn in a direction to eliminate this clearance and tighten the lock nut.

NOTE

On sprocket feed printers, perform the following adjustments at this time.

- (1) Platen Roller Sprocket Rings - Paragraph 232.
- (2) Paper Guide Posts - Paragraph 233.

169. RIGHT MARGIN ADJUSTING SCREW (Figure 61)

The printer should normally print seventy-two characters on a line (forty-four characters for typing units that print six characters to the inch instead of the standard ten) before spacing is blocked by the spacing stop pawl. To adjust, return the carriage to the left end of the line and back off the right margin adjusting screw. Then, with the right margin adjusting screw arm in engagement with its detent, space the carriage one less space than the number of characters desired per line: that is, seventy-one spaces for normal lines of seventy-two characters. (The carriage should then be in position to print the last character for desired length of line.) Adjust the stop screw so that the spacing stop lever is moved within .015" to .030" from a projection on the spacing stop sleeve.

NOTE

When printing seventy-two, seventy-six or forty-four characters per line, pile-ups should occur on the seventy-third, seventy-seventh and forty-fifth characters respectively.

169.1 STOP PLATE (For units not equipped with fraction type pallets) Refer to Figure 119 for location of parts)

The stop plate on the plunger, which operates the oscillator lever extension, should be positioned all the way toward the front of the basket and should not be used for any ribbon adjustment.

170. RIBBON OSCILLATOR LEVER

NOTE

This adjustment does not apply to printers equipped with the two color ribbon control mechanism or fraction type pallets.

With the ribbon lockout bar in its unoperated position (pulled outward toward the right), the ribbon should fully cover any character as it is being printed and the top edge of the ribbon should not be above the bottom edge of the printed character when the printing has been completed and the main shaft clutch has disengaged. To adjust, shift the platen to the SHIFT

position (up) and loosen the ribbon oscillator lever clamping screw and nut. Position the ribbon oscillator lever and tighten the clamping screw and nut. Check this adjustment with the platen in the UNSHIFT position (down). See Figure 67.

171. RIBBON LOCKOUT BAR (Figure 68)

NOTE

This adjustment applies only to those printers equipped with the adjustable ribbon lockout bar and does not apply to printers equipped with a two color ribbon control mechanism.

a. Hold the ribbon carrier down and move the ribbon lockout bar to the left against its stop. The ribbon should be locked sufficiently below the printing line to prevent printing of any portion of the characters. To adjust, position the lockout bar extension by means of its adjusting screws so that the ribbon oscillator just fails to operate when the lockout bar is in its operated (extreme left) position and the platen is in the UNSHIFT (Model 15) LETTERS (Model 20) position.

b. With the ribbon lockout bar in its operated position and with a 12 lb. scale hooked over the end of the ribbon lockout bar and pulling directly in line with the bar, it should not require more than 5 lbs. to move the lockout bar to its unoperated position.

172. SPACING CLUTCH TORQUE (Figure 69)

After the motor has run for at least ten minutes, tie the carriage return lock bar in its latched position and hook a 32 oz. scale over a tooth on the spacing escapement ratchet. With the main shaft rotating, hold off the rear escapement pawl and pull horizontally toward the rear of the unit. It should require from 18 to 24 ozs. to hold the spacing escapement ratchet stationary.

173. MARGIN SIGNAL BELL

The bell should ring on the sixty-sixth printed character for lines of seventy-two character length, on the seventieth for lines of seventy-six character length, and on the thirty-ninth for lines of forty-four character length. To adjust, return the carriage to the left end of the line. Then space the carriage sixty-six, seventy or thirty-nine spaces to the right, depending on the length of line being printed. Loosen the margin bell cam thumb screw and adjust the cam so that its right side is in contact with the margin bell pawl and tighten the thumb screw. (See Figure 58 for location of parts.)

173.1 SELECTOR CAM SLEEVE ASSEMBLY -
See Note (I) on Page 1-4 (Applies to 75
W. P. M. Units)

Make certain that the felt washers of the selector cam sleeve assembly do not interfere with the movement of the respective cam follower levers.

174. SELECTOR CLUTCH TORQUE (Figure 70)

a. The torque should be measured after the motor has been running at least ten minutes. With a 32 oz. scale hooked over the selector cam sleeve stop arm, it should require a pull of 14 to 18 ozs. for 60 or 75 wpm operation and 16 to 22 ozs. for 100 wpm operation to hold the cam sleeve stationary. This clutch torque depends on the condition of the felt washers and the clutch spring.

b. On units equipped with the 72515 nut and 72517 keyed nut, the clutch torque may be adjusted by the use of shims which may be placed between the clutch spring and the 72515 nut. The selector clutch spring must be removed from the shaft in order to insert the shims. Shims are available under the following numbers.

96763 Shim (.012" thick)
96764 Shim (.016" thick)
96765 Shim (.020" thick)

c. On units equipped with a 119540 keyed nut, a 122974 capstan nut, and a 122838 spacer in place of the 72515 nut and 72517 keyed nut, the torque may be regulated by positioning the capstan nut in the proper direction with a screwdriver.

NOTE

The 122974 capstan nut is split and the open ends are offset to insure a tight fit on the 119540 slotted nut. When installing the new parts in the field, the offset ends of the capstan nut must be held approximately in line by using a pair of pliers or a clamp in order to thread the capstan nut onto the slotted nut. The slotted nut can then be screwed into place on the main shaft. To prevent the capstan nut from being turned downward against the bearing, the 122838 spacer should be installed between the slotted nut and the bearing.

175. BAIL CAM UNIT FRICTION CLUTCH TORQUE (Figure 70)

Remove the function bail spring and hold the printing bail away from its adjusting screw. With the printer running on a closed line, hook a 32 oz. scale over the screw head on the cam unit and pull horizontally at right angles to the main

shaft. It should require 20 to 24 ozs. to move the cam in a direction opposite to its normal direction of rotation.

CAUTION

To prevent the clutch from engaging, block the clutch throwout lever in such a manner that it prevents the engaging of the clutch members.

176. DASHPOT VENT SCREW

The carriage should return from its right stop to its left stop without bouncing and with minimum shock when the carriage return lock bar is held in its latched position. Adjust by means of the dashpot vent screw and lock nut. (See Figure 60 for location of parts.)

KEYBOARD UNIT

177. LOCK LOOP SPRING TENSION (Figure 71)

Rotate the transmitting cam cylinder until the lock loop roller is resting on the low part of its cam. Hook an 8 oz. scale in the lock loop spring hole and pull in line with the spring. It should require 4 to 5 ozs. to start the lock loop moving.

178. LOCKING LEVER SHAFT BRACKET (Figure 71)

With the locking levers in the spacing position and the contact levers on the high part of their cams, there should be some clearance, not more than .010", between the contact levers and the locking levers when the locking levers are pressed downward by hand to make this clearance a minimum. Also, the locking levers should travel equally on either side of the lock loop blade when the UNSHIFT and BLANK (Model 15) or the "4" and "Y" (Model 20) keys are alternately depressed. To adjust, add or remove shims between the locking lever shaft bracket and the keyboard casting to meet the first requirement and, before tightening the bracket mounting screws, position the bracket laterally to meet the second requirement.

178.1 SELECTOR BAR ASSEMBLY BRACKET SHIMS (Figure 150) - See Note (J) On Page 1-4

When the "Q" key lever is fully depressed, all other key levers should have some play between the leather upstop and the selector bars. There should also be some clearance, not more than .030" between the high portion of the front selector bar (A-1) and the key levers in line with the high portions of the selector bars. To adjust, add or remove shims under the selector bar assembly bracket.

178.2 SELECTOR BAR ASSEMBLY BRACKET POSITION - See Note (J) On Page 1-4

The selector bar assembly bracket should be parallel to the rear key lever guide. The lower ends of the locking levers should fully engage their respective locking lever forks and there should be some clearance between the sides of the locking levers and the adjacent selector bars. To adjust, loosen the selector bar assembly bracket mounting screws and position the bracket. Tighten the mounting screws

179. TRANSMITTING CONTACTS GAP (Figure 71)

With any contact lever on the high part of its cam, the contact gap should be .017" to .025" (.015" to .025" for the start-stop contacts) when using a signal measuring device. If no signal measuring device is available, all contact gaps should be .017" to .023" for 60 or 75 wpm operation and .020" to .025" for 100 wpm operation. To adjust, bend the short contact spring.

180. CONTACT SPRING PRESSURE (Figure 72)

With any contact lever on the low part of its cam, it should require a pressure of 4-1/2 to 5-1/2 ozs. to open the contact when the push end of an 8 oz. scale is applied to the contact spring just above the contact point. To adjust, bend the longer contact springs. Recheck the contact gap adjustment.

181. CLUTCH SPRING COMPRESSION (Figure 73)

Hook a 32 oz. scale to the clutch driven member projection and pull directly in line with the shaft. It should require 9 to 12 ozs. to separate the clutch teeth.

182. CLUTCH (Figure 74)

There should be .005" to .015" clearance between the clutch teeth when the clutch is fully disengaged. To adjust, position the clutch throw-out lever by means of shims placed between the throwout lever post and the bracket.

183. LOCK LOOP ROLLER (See Figure 71 for location of parts)

NOTE

This adjustment applies only to those keyboards equipped with lock loops having an elongated hole for the roller pivot screw.

Rotate the keyboard shaft until the clutch teeth are disengaged. Press the lock loop roller against its cam to fully disengage the clutch teeth and position the locking levers directly below the lock loop blade to make the clearance a minimum. Under these conditions there should be .008" to .015" clearance between the lock loop blade and the locking lever having the least clearance. To adjust, position the roller pivot screw by means of its elongated mounting hole.*

* On some keyboards an eccentric roller pivot screw is used which provides extra adjusting margin. In these cases the shoulder screw should be mounted with the high part of its eccentric extending toward either end of the slot in the lock loop, depending upon in which direction the additional margin of adjustment is required.

184. UNIVERSAL BAR PILOT SCREWS (See Figure 74 for location of parts) - See Note (J) On Page 1-4

The universal bar should have some endplay, not more than .010"; the universal bar extension should be approximately in the middle of the space between the P and CARRIAGE RETURN key levers; and the trip-off pawl should clear the sides of the stop plate mounting screws and the locking lever bracket when the trip-off pawl is operated by depressing a key lever. To adjust, position the universal bar by means of its pilot screws.

185. TRIP-OFF PAWL STOP PLATE

a. Model 15 Typing Unit (Figure 74)

There should be .040" to .060" clearance between all key levers and the universal bar (.040" to .070" between the spacer key lever and the universal bar) when the trip-off pawl is resting against the end of the stop plate. To adjust, position the trip-off pawl stop plate by means of its elongated mounting holes.

b. Model 20 Typing Unit (Figure 150)

With the trip-off pawl resting against the stop plate and the intermediate pawl against its eccentric, there should be .070" to .080" clearance between the trip-off pawl and the intermediate pawl. To adjust, loosen the intermediate pawl eccentric lock nut and position the eccentric until the screw driver slot is in a horizontal position and the high part of the eccentric is toward the front of the unit. Loosen the trip-off pawl stop plate mounting screws and position the stop plate. Tighten the intermediate pawl eccentric lock nut and the trip-off pawl stop plate mounting screws.

185.1 UNIVERSAL BAR BEARING BRACKETS (Figure 150) - See Note (J) On Page 1-4

a. The universal bar bearing brackets should be in their rearmost position and parallel to the front edge of the selector bar assembly bracket. There should be .060" to .080" clearance between the key levers and the universal bar. To adjust, add or remove shims under the universal bar bearing bracket.

NOTE

On units equipped with an 8-1/2" spacer bar, there should be .060" to .090" between the universal bar and the spacer key lever. The .060" to .080" requirement still applies to other key levers.

b. Right Bracket Position

When the universal bar is held against the shoulder on the pilot screw, the universal bar extension should be approximately midway between the 5th and 6th key levers. To adjust, loosen the right bracket mounting screws and position the bracket to the right or left. Tighten the mounting screws.

c. Left Bracket Position

The universal bar should be free on its pivots and should have some end play, not more than .008". To adjust, loosen the left bracket mounting screws and position the bracket. Tighten the mounting screws.

d. After making adjustments (b) and (c) recheck adjustment (a).

186. INTERMEDIATE PAWL ECCENTRIC (Figure 74)

There should be .050" to .060" clearance between the trip-off pawl and the intermediate pawl when the trip-off pawl is resting against the end of the stop plate and the intermediate pawl is against its eccentric. To adjust, position the intermediate pawl eccentric.

187. CLUTCH THROWOUT LEVER ECCENTRIC (See Figure 74 for location of parts)

With the transmitter shaft in the stop position and the clutch fully disengaged, hold the clutch throwout lever against the driven clutch member. Under this condition the intermediate pawl should be held, without perceptible play, between the clutch throwout lever and the intermediate pawl eccentric. To adjust, position the clutch throwout lever eccentric.

188. TRIP-OFF PAWL ECCENTRIC (Figure 75)

With the clutch throwout lever held against the high part of its cam and the clutch throwout lever

eccentric held against the clutch throwout lever, the end of the trip-off pawl should clear the end of the intermediate pawl by not more than .004" when a key lever is slowly depressed. Adjust by means of the trip-off pawl eccentric screw.

NOTE

There are two positions of the eccentric screw that will provide the correct clearance. The high part of the eccentric should be positioned toward the rear of the keyboard in making this adjustment. If necessary, bend the rear extension of the trip-off pawl stop plate so that, with the trip-off pawl in its operated position, there is at least .002" clearance between the formed up end of the stop plate and the lower edge of the trip-off pawl.

189. CLUTCH THROWOUT LEVER SPRING TENSION (See Figure 74 for location of parts)

With the clutch teeth engaged and the clutch throwout lever resting against the low part of the clutch driven member, hold the intermediate pawl against its eccentric; at the same time hook an 8 oz. scale over the throwout lever just above the spring hole and pull in line with the spring. It should require 1-1/2 to 2-1/2 ozs. to start the lever moving.

190. TRIP-OFF PAWL SPRING TENSION (Figure 76)

Unhook the trip-off pawl spring. With an 8 oz. scale hooked in the spring eye, it should require 3-1/2 to 4-1/2 ozs. to pull the spring to position length.

191. TRANSMITTING CAM CYLINDER END PLAY (Figure 77)

The transmitting cam cylinder should have some end play, not more than .002". To adjust, position the bushing in the rear bearing bracket by means of its adjusting nuts.

192. KEY LEVER SPRING TENSION (Figure 78)

The openings between the ends of all key lever springs except the spacer key lever spring should measure 1-3/16". The spacer key lever spring should measure 1-15/16" across the opening between the ends. Adjust by bending the springs.

193. REPEAT SPACE ROD (Figure 79) - See Note (I) On Page 1-4

With the space bar fully depressed by applying

pressure at approximately the center of the bar, there should be .010" to .020" clearance between the clutchthrowout lever and the high part of the throwout cam. To obtain this requirement, adjust the repeat space rod by means of its adjusting nuts. (See Figure 74 for location of parts.)

194. REPEAT SPACE ROD BRACKET (Figure 80) - See Note (I) On Page 1-4

NOTE

This adjustment applies only to keyboards equipped with repeat space rod brackets having enlarged mounting holes (.205" in diameter) and a flat washer under the head of the bracket mounting screw.

With the space bar fully depressed, adjust the repeat space rod bracket so that there is some clearance, not more than .008", between the formed end of the repeat space rod and the flat side of the transmitter rear bracket measured at the closest point. The front face of the repeat space rod bracket should be parallel to the rear surface of the transmitter rear bracket. Adjust by means of the enlarged mounting hole.

195. REPEAT SPACE ROD SPRING TENSION (Figure 80) - See Note (I) On Page 1-4

Hook an 8 oz. scale over the repeat space rod just in front of the spring hole and pull in line with the spring. It should require 1 to 3 ozs. to start the rod moving.

BASE UNIT

196. MOTOR UNIT SLIP CONNECTION SPRINGS

a. With the motor unit in position on the base, hook a 4 lb. scale under one of the end motor unit slip connection springs just above the head of the terminal screw on the motor connection block, and pull toward the front of the base at right angles to the spring. It should require 2 to 4 lbs. to just break contact. Measure the pressure of the opposite end slip connection spring in the same manner. This pressure can be regulated by removing the motor unit and bending the springs.

b. With the motor unit removed and a straight edge placed across the two end springs, there should be some clearance, not more than .015", between the two inner springs and the straight edge. Adjust by bending the two inner springs.

197. LINE JACK SPRINGS

It should require 1 to 2 lbs. pressure, using a 12 lb. scale, on the curved part of the jack spring to just open the contacts. With the typing unit in position on the base, the line jack contacts should be separated .020" to .060". Bend the long contact spring to obtain these requirements.

198. KEYBOARD JACK SPRINGS

a. It should require 1 to 2 lbs. pressure, using a 12 lb. scale, on the curved part of the jack spring to just open the contact. With the keyboard inserted in the base, the keyboard jack springs should be separated .025" to .075". All slip connection springs should be in line.

b. To adjust, first remove the four base plate mounting screws and the base plate. Then remove the four screws that hold the slip connection mounting plate assembly to the base so that the bakelite cover can be removed, and then replace the four screws. Next measure the pressure of the two keyboard jack springs. With the keyboard inserted in the base the keyboard jack springs should now be separated by .005" to .025". This clearance may be measured from above the base by inserting a wire gauge between the contact springs. Bend the long contact spring of the two jack springs to obtain this spring tension and bend the short contact spring to provide this contact gap. (After the bakelite cover is replaced the jack contact springs should be separated by .025" to .075".) Remove the keyboard from the base and with a straight edge laid across the two keyboard jack springs, align the other slip connection contact springs by bending, so that they just touch the straight edge. Remove the four slip connection mounting plate screws and insert the bakelite cover in its original position. Replace the four mounting screws previously removed. Finally, install the base plate on the base by means of its mounting screws.

199. TYPING UNIT SLIP CONNECTION SPRING

Remove the typing unit from the base. Hold a straight edge flush against the left rear milled surface on the base and extend the straight edge over the printer slip connections. There should be 7/8" clearance (plus or minus 1/64") between the straight edge and the curved part of the springs. Bend the slip connection springs to obtain this clearance.

200. LINE RELAY JACK CONTACT GAP (Figure 81B) - See Note (I) On Page 1-4

a. When the jack plunger is held flush with the relay connection block mounting plate, there should be a gap of .010" to .015" between the contact points of No. 3 and No. 4 contact springs. Adjust by bending No. 3 contact spring.

b. When the jack plunger is held flush with the relay connection block mounting plate there should be .020" to .025" clearance between the contact points of No. 1 and No. 2 contact springs. Adjust by bending No. 2 contact spring.

201. LINE RELAY JACK CONTACT SPRING TENSION (Figure 81A) - See Note (I) On Page 1-4

When an 8 oz. scale is hooked to contact springs No. 1 or No. 4 at right angles to the springs, it should require a pull of 5 to 7 ozs. to separate the contact points of contact springs No. 1 and 2 or of contact springs No. 3 and 4, respectively. Adjust by bending No. 1 and 4 contact springs.

NOTE

The following four adjustments apply only to bases with send-receive-break mechanisms having single upper contact.

202. UPPER CONTACT LEVER SPRING TENSION (Figure 82A)

Unhook the upper contact lever spring and the safety pawl spring. With the send-receive lever in the SEND position (up), hook an 8 oz. scale over the spring bar on the upper contact lever and pull up vertically. It should require 5-1/2 to 6-1/2 ozs. to start the lever moving. Replace the safety pawl spring.

203. LOWER CONTACT LEVER SPRING TENSION (Figure 82A)

With the lower contact lever spring unhooked from the mounting bracket and the send-receive lever in the SEND position (up), hook a 32 oz. scale in the spring eye. It should require 9 to 11 ozs. to extend the spring to its position length. Replace the spring.

204. SAFETY PAWL SPRING TENSION (Figure 82B)

Hook an 8 oz. scale over the end of the lower extension on the safety pawl and pull at right

angles to the extension. It should require 1-1/4 to 2-1/4 ozs. to start the pawl moving.

205. SEND - RECEIVE - BREAK CONTACT SPRINGS (Figure 82C)

a. Viewing the base from the front, the send-receive-break contact springs are numbered 1, 2, 3, 4, 5, and 6 from left to right.

b. Move the send-receive lever to the SEND position (up).

(1) All contact points should meet across their entire surface.

(2) There should be some clearance, not more than .004", between the fibre insulator on the lower end of contact spring No. 4 and the lower contact lever to the right of it. Adjust by bending contact spring No. 4.

(3) There should be a clearance of .015" to .020" between contacts No. 3 and No. 4. No. 1 contact should not bear against No. 3. Adjust by bending contact spring No. 3.

(4) Contact No. 1 should exert a pressure against contact No. 2. Hook an 8 oz. scale around contact spring No. 1 just below the contact point and pull horizontally to the left. It should require 3 to 4 ozs. to just separate the contacts. Adjust by bending contact spring No. 1.

(5) There should be a slight clearance, not more than .004", between the fibre insulators on springs No. 1 and No. 3. Adjust by bending contact spring No. 2 and recheck the pressure of spring No. 1.

c. Move the send-receive lever to the RECEIVE position (down).

(1) With the left end of the upper contact lever held against the top of the notch in the safety pawl, there should be at least .008" clearance between the fibre insulator on the No. 6 contact spring and the extension on the upper contact lever. Make certain that contacts No. 5 and No. 6 are separated by at least .015" when the break lever is operated. Adjust by bending contact spring No. 5.

(2) Contact No. 6 should exert a pressure on contact No. 5. Hook an 8 oz. scale around contact spring No. 6 just above the contact point and pull horizontally to the right. It should require 4-1/2 to 5-1/2 ozs. to just open the con-

tacts. Adjust by bending contact spring No. 6. Recheck (1).

NOTE

The following six adjustments apply only to bases with send-receive-break mechanism having two upper contacts.

206. STOP LEVER PLATE (Figure 83A)

With the left end of the upper contact lever held up against the stop lug on the stop lever plate, there should be .004" to .015" clearance between the shoulder in the notch in the upper contact lever and the top of the lower contact lever. To adjust, position the stop lever plate by means of its mounting screw.

207. BREAK LEVER ADJUSTING PLATE (Figure 83B)

There should be some clearance, not more than .015", between the rear upper corner of the beveled edge on the left end of the upper contact lever and the lower front edge of the stop lug on the stop lever plate when the break lever is slowly operated by hand until the two edges are just opposite each other. To adjust, position the break lever adjusting plate by means of its adjusting screw.

208. STOP LUG (Figure 84A)

The upper extension of the stop lever should rest against the stop lug on the mounting bracket when the stop lever is in its unoperated position, and there should be some clearance, not more than .030", between the rear side of the upper contact lever and the front edge of the stop lever plate. Adjust, if necessary, by bending the stop lug on the mounting bracket.

209. UPPER CONTACT LEVER SPRING TENSION (Figure 85B)

With the send-receive lever in the SEND position (up), and the No. 3 contact spring held away from the extension on the upper contact lever, hook an 8 oz. scale under the left end of the contact lever at the spring hole and pull up vertically in line with the spring. It should require 3 to 5 ozs. to start the upper contact lever moving.

210. STOP LEVER SPRING TENSION (Figure 84A)

With the stop lever resting against the stop

lug on the mounting bracket, hook an 8 oz. scale in the spring mounting hole in the stop lever and pull in line with the spring. It should require 1 to 2 ozs. to start the stop lever moving.

211. SEND - RECEIVE - BREAK CONTACT SPRINGS (Figures 83, 84, and 85)

a. Viewing the base from the front, the send-receive-break contact springs are numbered 1, 2, 3, 4, 5, and 6 from left to right.

b. Move the send-receive lever to the SEND position (up).

(1) All contact springs and points should be in line.

(2) There should be some clearance, not more than .008" between the fibre insulator on the lower end of No. 1 contact spring and the extension on the lower contact lever to the right of it. When checking this clearance, the lower contact lever should be held firmly against its stop. Adjust by bending contact spring No. 2.

3. Contact No. 1 should exert a pressure against contact No. 2. Hook an 8 oz. scale around contact spring No. 1, just below the contact point, and pull horizontally toward the left. It should require 1 to 2 ozs. to just separate contacts No. 1 and No. 2. Adjust by bending contact spring No. 1. Recheck (2).

(4) All the clearance requirements, pertaining to contact springs No. 3 to No. 6 inclusive, given in the following paragraphs will most always be met if these 3 preliminary requirements are met:

(a) The stiffeners for contact springs No. 4 and No. 5 should be straight.

(b) Contact springs No. 4 and No. 5 should rest against their respective stiffeners with perceptible tension. There should be no gaps between the ends of the stiffeners and the contact springs when the contacts are open. However, a gap or not more than .004" will be permissible at any other point.

(c) With the send-receive lever in the RECEIVE position (down), the extension on the upper contact lever should be approximately midway between imaginary lines extending up from contact springs No. 4 and 5. If necessary, bend the extension on which the double contact springs are mounted to meet this requirement. It will be permissible to vary this requirement

if necessary, in cases where the clearance requirements given in the following paragraphs cannot be met.

(5) With the send-receive lever in the SEND position (up), there should be a clearance of at least .015" between No. 3 and No. 4 contacts. If necessary to adjust, see (4).

(6) Move the send-receive lever to the RECEIVE position (down) and make sure that No. 3 and No. 4 contacts close.

(7) There should be at least .015" clearance between No. 1 and No. 2 contacts. Adjust by bending contact spring No. 2. Recheck (2).

(8) Contact No. 3 should exert a pressure against contact No. 4. Hook an 8 oz. scale around contact spring No. 3 just above the contact point and pull horizontally toward the left. It should require 1 to 2 ozs. to just separate contacts No. 3 and No. 4. Adjust by bending contact spring No. 3. Recheck (5).

(9) With the left end of the upper contact lever held against the stop lug on the stop lever plate, there should be at least .008" clearance between the fibre insulator on No. 6 contact spring and the extension on the upper contact lever. Make certain that contacts No. 5 and No. 6 are separated by at least .015" when the break lever is operated. If necessary to adjust, see (4).

(10) Contact No. 6 should exert a pressure against contact No. 5. Hook an 8 oz. scale around contact spring No. 6 just above the contact point and pull horizontally toward the right. It should require 4-1/2 to 5-1/2 ozs. to just separate contacts No. 5 and No. 6. Adjust by bending contact spring No. 6. Recheck (9).

212. CONTROL RELAY

a. For BREAK operation the control relay should be adjusted to meet the following requirements: (See Figure 86A)

(1) With the relay plunger held operated, there should be .005" to .015" clearance between the contact surfaces of the outer and middle contact springs. Adjust by bending the outer contact spring.

(2) With the plunger held operated, there should be .025" to .030" clearance between the contact surfaces of the inner and middle contact springs. Adjust by bending the inner contact spring.

(3) With the relay plunger in the unoperated position, hook an 8 oz. scale over the middle contact spring, as close as possible to the wiper contact, and pull at a right angle to the spring. It should require 5 to 6 ozs. to cause the middle contact to break contact with the inside contact. To adjust, bend the middle contact spring. Recheck (2).

b. For MAKE operation the control relay should be adjusted to meet the following requirements: (See Figure 86B)

(1) Hold the relay plunger operated and hook a 32 oz. scale over the end of the outer contact spring and pull horizontally at right angles to the contact spring. It should require 12 to 16 ozs. to cause the outer contact spring to break contact with the middle contact spring. Adjust by bending the outer contact spring.

(2) With the relay plunger held operated, there should be .030" to .040" clearance between the contact surfaces of the inner and middle contact springs. Adjust by bending the inner contact spring.

(3) Hook an 8 oz. scale over the middle contact spring at the side of the contact and pull horizontally at right angles to the contact spring. It should require 1-1/2 to 2 ozs. to cause the middle contact spring to break contact with the inner contact spring. Adjust by bending the middle contact spring. Recheck (2).

c. The operating current for the control relay should be between .050 and .060 ampere when adjusted for either MAKE or BREAK operation.

NOTE

The following two adjustments apply only to bases used with receiving-only printer covers.

213. SEND - RECEIVE - BREAK MECHANISM (SINGLE UPPER CONTACT) Figure 87A.

When the printer is used with a receiving only cover, it is necessary to reposition the send-receive lever to provide clearance for the printer cover. Normally the send-receive handle is positioned below the latch handle with the projecting lug on the operating end pointing upward. Remove the shoulder screw and lock nut used to mount the send-receive lever and break lever to the bracket. Turn the send-receive lever over and position it above the break

lever with the projecting lug on the operating end pointing downward. Insert the shoulder screw and replace the lock nut.

214. SEND - RECEIVE - BREAK MECHANISM (TWO UPPER CONTACTS) Figure 87B.

When the printer is used with a receiving only cover, it is necessary to reposition the send-receive lever, the break lever adjusting plate, the adjusting screw and nut, and the send-receive lever and break lever bushing. Unhook the break lever spring, loosen the mounting screw nut and remove the screw. Loosen the adjusting screw nut and remove the adjusting screw and break lever adjusting plate. Re-mount the break lever adjusting plate making certain that the screw does not extend beyond the break lever. Insert the bushing with the short shoulder on the outside. Place the send-receive lever with the projecting lug to the rear and mount the assembly on the bracket. Replace the break lever spring.

**CENTER CONTACT GOVERNOR
ADJUSTMENTS**

215. ALIGNMENT AND SQUARENESS OF GOVERNOR CONTACTS

a. All governor contacts can be adjusted for alignment of edges; only those governor shells which provide elongated mounting holes for the fixed contact bracket permit adjustment of the contact for height by positioning the contact bracket.

b. The governor contacts should be in line and meet squarely so that maximum contact surface is provided. (Check with the retractile spring tension adjusted so that the contacts just make, or to the limit of the adjusting screw.)

(1) Line up edges of contacts by means of the floating contact hinge mounting screw.

(2) Adjust contacts for squareness from right to left by positioning the height of the fixed contact bracket using the elongated mounting holes in the governor shell.

(3) To adjust from front to back, twist the floating contact hinge, applying pressure to the arm near the contact.

NOTE

Check by use of a .002" gauge (smaller if available). Check with gauge between edges of the contacts to see that the gauge enters (or does not enter) equally on all sides.

216. SPEED ADJUSTING WHEEL FRICTION WASHER SPRING TENSION (Figure 88) See Note (H) on Page 1-4.

a. Turn the adjusting wheel so that the tension on the governor contact is 13 to 14 ozs. Measure by hooking a 32 oz. scale over the contact spring arm next to the contact and pulling parallel to the speed adjusting spring.

b. To measure the pressure of the speed adjusting wheel friction washer, insert a bank pin in the leather rim (radially), and hook a 32 oz. scale over the pin at the periphery of the adjusting wheel and pull at right angles to the radius. It should require 16 to 24 ozs. to start the wheel moving. To adjust this tension, remove the friction washer and bend the large projections.

217. INNER AND OUTER DISC CONTACT SPRING (Figure 89) See Note (H) on Page 1-4.

a. The distance from the inner surface of the governor cover to the highest point on the contact springs should be 25/32" to 27/32".

b. Place a 5/16" socket wrench over the nut located in the center of the governor cover which is used to hold the contact springs in place. With a suitable scale, measure the radial distance from the vertical surface of the wrench to the point where the scale touches the curved surface of the inner disc contact spring. This distance should be 17/32" to 19/32".

c. In a similar manner, measure the distance from the wrench to the point of the contact on the outer disc contact spring. This distance should be 7/16" to 1/2".

d. Adjust by bending the inner and outer disc contact springs.

218. GOVERNOR BRUSH SPRING PLATE BRACKET

a. The spring plate bracket should be positioned to meet the following requirements:

(1) A line established by the center of the outer disc and the center of one of the brushes should pass through some portion of the other brush. (Figure 90A)

(2) The surface of the brush spring plate bracket on which the brush spring plate is mounted should be in line with the outer surface

that part of the governor cover on which the target is mounted. (Figure 90B)

(3) The bracket should be parallel to the edge of the motor base plate.

b. To adjust, position the brush spring plate bracket by means of its enlarged mounting holes.

219. GOVERNOR BRUSH SPRING PRESSURE (Figure 90B)

a. Hook an 8 oz. scale over the inner disc brush spring just to the right of the carbon contact brush, as viewed from the rear of the motor, and pull horizontally away from the motor. It should require 4-1/2 to 5-1/2 ozs. to start the brush moving away from the disc.

b. Apply an 8 oz. push scale against the outer disc brush spring just to the right of the carbon contact brush, as viewed from the rear of the motor, and push horizontally toward the motor. It should require 4-1/2 to 5-1/2 ozs. to start the brush moving away from the disc.

c. To obtain the correct brush spring pressure, remove and bend the brush springs. When the springs are replaced and the spring pressure obtained, see that the contact brushes lie flat against their respective discs and that the outer edges of the brushes are either flush with or not more than 3/64" inside the outer edges of the discs.

220. GOVERNOR ADJUSTING BRACKET (Figure 90B)

There should be .020" to .060" clearance between the speed adjusting wheel and the speed adjusting surface on the bracket. Adjust by bending the governor adjusting bracket.

221. SPEED ADJUSTING LEVER STOP PLATE (Figure 90B)

There should be .006" to .050" clearance between the adjusting lever wearing strip and the governor when the speed adjusting lever is held against the stop plate. To adjust, position the adjusting lever stop plate by means of its elongated mounting holes.

222. GOVERNOR SHIMS (Figure 90B)

With the governor speed adjusting lever in its unoperated position, there should be at least .006" clearance between the adjusting lever wearing strip and the speed adjusting wheel

when the wheel is opposite the wearing strip, the wearing strip is tight against the casting, and all the end thrust of the motor armature is taken up in a direction to make this clearance a minimum. Adjust by means of shims placed on the armature shaft between the governor hub and the end frame casting of the motor. (If wearing strip is not absolutely tight against the casting, bend it until it is.)

SYNCHRONOUS MOTOR ADJUSTMENTS

223. SYNCHRONOUS MOTORS WITH THREE-BRUSH STARTING SWITCH

NOTE

These requirements should not be checked unless there is reason to believe the starting switch is out of adjustment.

a. Remove the motor unit from the base and remove the motor fan and pinion.

b. Remove the switch end shield screws and the switch commutator mounting screws. Remove the switch end shield.

c. Pull out the rotor until the brush holder spring is accessible and remove the spring.

d. The tension of the spring for 60 cycle motors should measure 2 to 2-1/2 ozs. when extended to a length of 5 inches, using an 8 oz. scale. The tension of the spring for 50 cycle motors should measure 1-3/4 to 2 ozs. when extended to a length of 5 inches, using an 8 oz. scale.

e. The brush holders should be mounted by means of the center set of mounting holes and should be free.

f. The brush holder stop pins should be safely within the holes of the fibre disc when all the play in the brush holders has been taken up to make the engagement of the pins with the disc a minimum.

g. Replace the brush holder spring, making certain that the spring eyes are fully engaged with each other.

h. Replace the switch commutator screws and tighten the two screws alternately a little at a time until both screws are tight.

i. Replace the switch end shield screws using the same precaution in tightening as in the foregoing item.

j. Apply the push end of a 12 lb. scale against the fan end of the shaft and push parallel to the shaft. It should require at least 7 lbs. pressure to start the shaft moving.

k. Replace the motor fan and pinion. Replace the motor unit on the base and check the motor plate adjustment.

VARIABLE FEATURES

SPROCKET FEED PRINTER ADJUSTMENTS

224. LEFT PRESSURE ROLLER LEVER (Figure 91)

When an R wrench (.125" thick) is placed between the platen and the knurled surface of the right pressure roller, the left pressure roller should rest against the platen. The centers of the pins on the platen should line up with the center of the groove in the left pressure roller when the roller is at the midpoint of its end play. Adjust by means of the left pressure roller lever clamping screw.

225. RIGHT PRESSURE ROLLER LEVER SPRING COLLAR (Figure 91)

With the right pressure roller lever against the right pressure roller lever spring collar, the centers of the pins on the platen should line up with the center of the groove in the right pressure roller when the roller is at the midpoint of its end play. The right pressure roller lever should have some end play, not less than .002". Adjust by means of the right pressure roller lever spring collar.

226. RIGHT PRESSURE ROLLER LEVER SPRING TENSION (Figure 92)

Hook an 8 oz. scale over the right pressure roller bearing screw nut and pull vertically upward. It should require 5 to 8 ozs. to start the right pressure roller moving away from the platen. The torsion can be varied by rotating the right pressure roller lever spring collar on the shaft.

NOTE

If the right pressure roller lever spring collar is rotated to secure this spring tension, the "Right Pressure Roller Lever Spring Collar" should be rechecked.

227. LEFT PRESSURE ROLLER SPRING TENSION (Figure 92)

Hook an 8 oz. scale over the left pressure roller bearing screw nut and pull vertically upward. It should require 5 to 8 ozs. to start the left pressure roller moving away from the platen.

228. PAPER STRIPPER

a. There should be some clearance, not more than .020", between the top projection of the strippers and the bottom of the platen groove, when the lower projection is held against the bottom of the platen groove. To adjust, bend the strippers to meet this requirement.

b. There should be some clearance between the strippers and the rubber side of the grooves in the platen, when the strippers are held against their locating collars. Under these conditions there should also be some clearance between the strippers and the platen roll sprocket rings. Adjust by means of the locating collars. Check each stripper for one complete revolution of the platen.

229. PULLEY COLLARS (Figure 92)

The left and right pulleys should have some end play, not more than .010". Adjust by means of the pulley collars and set screws.

230. LEFT MARGIN ADJUSTING SCREW (Figure 60)

With the type bar carriage at the left end of the line and the carriage return clutch members fully engaged, the left end of the letter "M" should print 1/64" to 1/8" from the paper stripper groove adjacent to the left sprocket ring (see figure 103). To adjust, turn the left margin adjusting screw in so that it will not interfere with positioning the carriage. Move the carriage to a position where the letter "M" will be printed at the left end of the line within the foregoing specified limits and engage the carriage return clutch by operating the dashpot lever to hold the carriage in this position. Make certain that the carriage return clutch members are fully engaged. Then reposition the adjusting screw so that when the lock nut is slightly tightened to take up the end play in the threads and a horizontal pull of 8 lbs. is exerted on the dashpot lever (new style) applied with a 12 lb. scale at right angles to the curved surface 1/32" behind the margin adjusting screw (10 lbs. on old style

dashpot lever applied just in front of the shoulders), there is a slight clearance, not more than .002", between the end of the screw and the dashpot lever. Turn the left margin adjusting screw one-sixth turn in a direction to eliminate this clearance and tighten the lock nut.

NOTE

When it is desired that the printing be located at a given point with reference to a vertical line on the forms, the platen unit may be shifted as much as .030" to the left or right of its standard adjustment by means of its pilot screws, provided that care is taken to avoid interference by the platen with either side frame. If more than .030" is required, the printing point may be shifted .050" by shifting the spacing shaft gear one tooth with relation to the main shaft gear. To do this, place the carriage in its extreme left position, loosen the spacing shaft top bearing retaining plate, raise the spacing shaft until the gears are disengaged, turn the shaft clockwise one tooth, and re-engage the gears. Tighten the retaining plate mounting screws.

CAUTION

When the printing point is shifted by either or both of the foregoing methods, recheck the left margin adjustment. Also make certain that the line feed link and the shift link do not bind.

231. PLATEN FRICTION ASSEMBLY (Figure 93)

a. Lift the pressure rollers (Figure 91) off the platen. Unhook the line feed detent lever spring and place the platen handle vertically upward. Hook a 32 oz. scale over the end of the handle and pull horizontally toward the front of the printer. When sprocket feed paper forms having 1 to 3 copies are to be used, it should require 14 to 16 ozs. to start the platen rotating. When forms having 4 to 6 copies are to be used, it should require 10 to 12 ozs. to start the platen rotating.

b. This friction can be varied by rotating the adjusting nuts on the friction assembly. Replace the line feed detent lever spring and lower the pressure rollers against the platen.

NOTE

On units equipped with a handwheel in place of the platen crank, position the handwheel so that the 1/8" diameter hole is located vertically above the platen shaft. Hook the spring scale in the hole and pull horizontally toward the front of the typing unit. Under these conditions, the above requirements should be met.

232. PLATEN ROLLER SPROCKET RINGS (Figure 94)

The bottom of a printed line of the letter N should be 1/32" (plus or minus 1/64") above a line drawn horizontally on a sheet of sprocket feed paper between the lower edges of corresponding perforations. To adjust, loosen the three set screws in each sprocket ring and rotate the rings.

233. PAPER GUIDE POSTS (Figure 91)

When sprocket feed paper forms are inserted in the printer, the paper guide posts in the loading plate should just clear the edges of the forms. To adjust, position the two guide posts in their elongated mounting holes.

234. COVER PAPER GUIDE POSTS (Figure 95)

Place the cover on the printer. If multiple copy forms are to be used, align the sprocket holes in the first of a length of forms, and place a paper clip over the leading edge to hold the forms in alignment. Insert the forms in the machine by threading the leading edge between the surface of the paper guide and the guide strip, thence through the slot in the cover, under the center retarding rod on the typing unit and over the surface of the loading plate under the platen; with the leading edge of the forms resting against the ribbon guide and with the pressure rollers in their extreme raised position, press the forms to the platen near the ribbon guide, and turn the platen crank to carry the edge of the forms past the ribbon guide. Set the forms on the sprocket pins, being sure that the pins are in their proper holes so that the paper is straight, and lower the pressure rollers to hold the forms in place. Then take up the slack in the forms by grasping them just below the paper guide and pulling them straight down. The two guide posts on the loading plate to the rear of the platen should be adjusted so that they just clear the sides of the paper when it is straight and taut. The four guide posts on the paper

guide should have a similar clearance. Adjust by positioning the guide posts in their elongated mounting holes.

PLATEN INDEXING MECHANISM ADJUSTMENTS FOR SPROCKET FEED PRINTERS

235. CONTACT LEVER ECCENTRIC (Figure 96)

With the contact lever on the high part of its cam, there should be a clearance of .025" to .035" between the top of the switch plunger and the contact lever. To adjust, loosen the gear adjusting plate clamp screw and raise the plate extension as far as possible; retighten the clamp screw. Under this condition position the contact lever eccentric to meet the above requirement. Check electrical operation of contacts by rotating cam.

NOTE

There are two positions of the eccentric which will meet the above requirement. The position with the high part toward the front of the unit should be used.

236. PLATEN FRICTION ASSEMBLY

This adjustment applies only to units which use form lengths of 5" or less and which use the friction assembly on the right end of the platen shaft. The torque should be measured and adjusted as outlined in paragraph 260 with the gears of the indexing mechanism disengaged.

237. REMOVABLE GEARS

There should be a perceptible amount of backlash in the two outer gears. To adjust, loosen the gear adjusting plate clamp screw and rotate the plate. Retighten the clamp screw.

NOTE

The backlash should be determined by holding the platen stationary and rotating the idler gear assembly. Check this adjustment for one full revolution of the larger removable gear.

238. CAM CLUTCH TORQUE

With the hand wheel rotated counterclockwise and the right-hand stop screw (left side view) against the stop pin it should require a minimum of 44 oz. pull, on a 64 oz. scale applied in a horizontal position at the drop-off point of

the cam, to rotate the cam counterclockwise. To adjust, remove the two stop screws from the hand wheel. Rotate the hand wheel counterclockwise until the cam surfaces are at the top. Hold the cam and rotate the hand wheel until it requires a minimum of 44 oz. tension to start the cam assembly rotating, when applying a 64 oz. scale at the drop-off point of the cam in a horizontal direction toward the rear. Rotate the hand wheel clockwise (if necessary) until the first tapped hole passes to the right side of the stop pin. (Stop pin positioned at the top.) Mount the first stop screw in this tapped hole. Recheck minimum clutch torque requirement of 44 ozs. Mount the second stop screw in the first tapped hole counterclockwise of the first stop screw.

239. CONTACT LEVER SPRING TENSION (Figure 96)

With the contact lever on the high part of the cam, hook a 32 oz. scale on the contact lever, just below the cam following surface, and pull in a horizontal direction. It should require 10 to 14 ozs. to start the lever moving.

MECHANICAL MOTOR STOP ADJUSTMENTS

240. MOTOR STOP LEVER BRACKET (Figure 97)

With the platen in the FIGURES position, set up the motor stop combination and rotate the main shaft slowly until the motor stop function lever is completely selected. The latching surface of the inner motor stop pawl should overtravel the rearmost surface of the motor stop pawl latch .010" to .025" when the armature is held in the MARKING position. To adjust, place the typing unit on its right side and position the motor stop lever bracket by means of its enlarged mounting holes. When making this adjustment, the motor stop pawl backstop should not be in contact with the inner pawl.

241. MOTOR STOP LEVER ECCENTRIC (Figure 97)

Rotate the main shaft until the printing bail is in its extreme rear position and the locking lever is on the high part of the locking cam. Then, with the armature in the MARKING position, engage the inner motor stop pawl with the motor stop pawl latch. The motor stop lever eccentric should be in contact with the lower arm of the motor stop release lever when the release lever stud touches the locking lever. To adjust, position the motor stop lever eccentric.

**MOTOR STOP LEVER BACKSTOP
SCREW (Figure 97)**

With the platen in the LETTERS position, set up the motor stop combination and rotate the main shaft until the printing bail is in its extreme forward position. Make certain that the motor stop pawls are released from the latch. There should be some clearance, not over .002", between the rear extension of the upper case H function lever and the lower edge of the motor stop lever. To adjust, loosen the backstop screw lock nut and position the backstop screw. Tighten the lock nut.

**243. MOTOR STOP PAWL BACKSTOP
(Figure 97)**

With the printing bail in its extreme rear position and the motor stop release lever eccentric moved away from the outer stop pawl, the motor stop pawl latch should clear both motor stop pawls by an approximately equal distance (at least .010") when the armature is moved to the MARKING or SPACING positions. To adjust, loosen the backstop mounting nut and rotate the backstop.

**244. MOTOR STOP RELEASE LEVER EC-
CENTRIC (Figure 97)**

Rotate the main shaft until the printing bail is in its extreme rear position and the locking lever is on the high part of the locking cam. Then, with the armature in the MARKING position, engage the inner motor stop pawl with the motor stop pawl latch. The motor stop release lever eccentric should just touch the outer motor stop pawl when the lower arm of the motor stop release lever is in contact with the motor stop lever eccentric and the outer pawl is against the motor stop pawl backstop. To adjust, position the motor stop release lever eccentric by means of its mounting screw.

**245. MOTOR STOP PAWL SPRING COM-
PRESSION (Figure 97)**

With the printing bail in its extreme rear position, hook an 8 oz. scale, held in a horizontal position, over the inner stop pawl just in front of the backstop, and pull at right angles to the pawl. It should require 1/2 to 1 oz. to start the pawl moving.

**246. MOTOR STOP LEVER SPRING TEN-
SION (Figure 97)**

Unhook the motor stop contact lever spring. With the motor stop lever in the unoperated

position, hook an 8 oz. scale over the head of the screw which mounts the motor stop lever eccentric and pull toward the rear of the printer. It should require 1 to 1-1/2 ozs. to start the lever moving. To adjust, position the spring bracket on the post of the selector unit. Replace the motor stop contact lever spring.

**247. MOTOR STOP CONTACT LEVER
SPRING TENSION (Figure 97)**

Hold off the contact spring if it rests on the motor stop contact lever. Hook an 8 oz. scale in the contact lever spring hole and pull in line with the spring. It should require 4-1/4 to 5-1/4 ozs. to start the contact lever moving.

**248. MOTOR STOP FUNCTION LEVER
SPRING TENSION (Figure 98)**

With the motor stop function lever resting against the rear edges of the names, but not selected, hook a 12 lb. scale under the extreme front end of the lever and pull at right angles to the lever toward the top of the printer. It should require 5 to 6 lbs. to start the lever moving.

**249. RIGHT MOTOR STOP CONTACT (Fig-
ures 97 and 98)**

a. With the printing bail in its extreme rear position, hold the selector armature in the MARKING (operated) position and engage the inner motor stop pawl with its latch. The contact spring mounting surface of the right contact spring bracket should be parallel to the top edge of the send-receive mechanism plate (gauge by eye). There should be either some clearance, not more than .010", between the insulated end of the light contact spring of the right motor stop contacts and the upper end of the contact operating lever, or, there should be not more than 1/2 oz. pressure against the upper end of the contact operating lever from the insulated end of this spring if the insulated end of the spring is bearing against the operating lever. To adjust, position the right contact spring bracket by means of its mounting holes, and, if necessary bend the light contact spring.

NOTE

When adjusting, make certain that the heavy contact spring does not bear against the light spring.

b. With the selector armature in the SPACING (unoperated) position and the outer motor

stop pawl engaged with its latch, there should be a gap of .012" to .020" between the contacts. To adjust, bend the heavy spring of the right motor stop contacts.

250. LEFT MOTOR STOP CONTACT (Figure 98)

a. With the printing bail in its extreme rear position, there should be either some clearance, not more than .010" between the insulated end of the light contact spring of the left motor stop contacts and the lobe on the front extension of the motor stop function lever or, not more than 1/2 oz. pressure against this lobe if the insulated end of the light contact spring is bearing against it. To adjust bend the light contact spring.

NOTE

When adjusting make certain that the heavy spring does not bear against the light spring.

b. With the motor stop function lever selected and the main shaft rotated until the right-hand motor stop contact is just at the point of opening, the left-hand motor stop contact should just close. With the LETTERS combination selected and the main shaft rotated until the printing bail is in its extreme forward position, there should be at least a .010" gap between the left-hand motor stop contacts. To adjust, bend the heavy contact spring of the left-hand motor stop contact.

251. RESET LEVER LOWER ADJUSTING SCREW (Figure 99A)

With the platen in the UNSHIFT position (down), the motor stop combination selected and the motor rotated until the printing bail is in its extreme forward position, there should be some clearance, not more than .002", between the head of the lower adjusting screw and the lower surface of the front extension of the motor stop function lever when the send-receive lever is in the SEND position (up). Adjust the height of the lower adjusting screw to regulate this clearance.

252. RESET LEVER DOWNSTOP SCREW (Figure 99A and 99B)

With the send-receive handle in the SEND position (up) and the toe of the intermediate lever under the blank function lever extension, select the BLANK combination and rotate the

main shaft until the function bail roller just leaves the cam surface of the blank function lever. Then depress the break key and immediately release it. The stop lever plate should just latch the upper contact lever (on bases equipped with send-receive-break mechanism having two lower contacts, the safety pawl should latch the operating lever), and there should be some clearance, not more than .002" between the stop lever plate and the upper contact lever (or between the safety pawl and the operating lever). To adjust, position the reset lever downstop screw.

"SHIFT - BLANK - STOP" MECHANICAL MOTOR STOP ADJUSTMENTS

253. ADAPTER PLATE (TRIGGER ASSEMBLY) (Figure 100)

a. With the SPACE combination set up on the vanes and the main shaft rotated until the function levers rest against the vanes, the blocking surface of the blocking lever should clear the front edge of the motor stop function lever by not more than .002" and its rear extension should be in contact with the right side of the motor stop function lever. To adjust, position the adapter plate or trigger assembly with the mounting screws loosened (the trigger assembly is part of the Automatic Carriage Return and Line Feed Assembly).

b. With the "Figure H" combination selected and the motor stop function lever blocked by its blocking lever, the motor stop function lever should not block the travel of the printing bail. If necessary, refine the position of the adapter plate or trigger assembly.

254. TRIGGER GUIDE (Figure 101) - Applies only to units equipped with the Automatic Carriage Return and Line Feed Mechanism.

a. With the letter "O" combination selected and the main shaft rotated until the printing bail is in its extreme forward position, there should be some clearance, not more than .010", between the carriage return latch bar and the lobe on the carriage return extension of the bail assembly.

b. With the main shaft in the stop position and the play taken up to make the clearance a minimum, there should be at least .005" clearance between the blocking edge of the trigger extension and the front edge of the automatic carriage return and line feed function lever.

c. To adjust, position the trigger guide by means of its elongated mounting holes.

d. Position the 88969 spring above the blocking lever.

255. BLOCKING LEVER SPRING (Figure 102)

a. When the send-receive lever is moved from the "send" to the "receive" position and vice versa, the humps of the spring should travel an equal amount above and below the center of the forward end of the blocking lever. To adjust, position the spring with its clamping screws loosened.

b. With the send-receive lever in the "send" position, set up the BLANK selection and rotate the main shaft until the blank function lever rests against the vanes. See that the intermediate lever is not under the blank function lever. Rotate the "T" lever clockwise until it touches the blank function lever. See that the extension of the blocking lever rests against the line feed function lever. Under these conditions, there should be some clearance, not more than .004", between the hump on the spring and the forward extension of the blocking lever. To adjust, bend the left arm of the spring.

c. With the printing bail in its extreme rear position, rotate the "T" lever clockwise. With the send-receive lever in the "send" position and the "T" selection set up on the names, rotate the main shaft until the printing bail is in its extreme forward position. See that the blocking lever is in front of the motor stop function lever, and that the extension of the blocking lever rests against the side of the motor stop function lever. With the universal function lever in contact with the "T" lever, there should be some clearance, not more than .004", between the hump on the spring and the forward extension of the blocking lever. To adjust, bend the right arm of the spring.

UPPER CASE "H" ELECTRICAL MOTOR CONTROL ADJUSTMENTS FOR UNITS EQUIPPED WITH A HOLDING MAGNET SELECTOR

NOTE

The first two adjustments apply to the typing unit. The remainder apply to the motor stop assembly on the base.

256. MOTOR STOP FUNCTION LEVER SPRING TENSION

With the motor stop function lever against the rear edges of the vanes, but not selected, hook a 12 lb. scale under the extreme front end of the function lever and pull vertically. It should require from 5 to 6 lbs. to start the function lever moving.

257. MOTOR STOP CONTACT

a. With the printing bail in its extreme rear position, there should be some clearance, not more than .006" between the insulated end of the light contact spring and the lobe on the front extension of the motor stop function lever. To adjust, bend the light motor stop contact spring, making sure that the heavy spring does not bear against the light spring.

b. With the platen in the LETTERS position and the "H" combination selected, rotate the main shaft until the motor stop function lever rests against the vanes. There should be a gap of .010" to .015" between the contacts of the light and heavy springs. To adjust, bend the heavy contact spring. Recheck a.

NOTE

If this motor stop mechanism has been installed in the field and if it was necessary to loosen the function lever comb mounting screws when installing the motor stop function lever, the following adjustments should be checked.

SIGNAL BELL LATCH BAR LATCH-
Paragraph 134

CARRIAGE RETURN LATCH BAR
LATCH - Paragraph 140

258. START MAGNET CORE (See Figure 103 for location of parts)

With the start magnet armature held in the operated position, there should be not more than .004" clearance between the start magnet armature and the shorter core. Adjust by varying the number of shims between the start magnet cores and the yoke.

259. STOP MAGNET CORE (See Figure 103 for location of parts)

With the stop magnet armature held in the operated position, there should not be more

than .004" clearance between the stop magnet armature and either the stop magnet core or yoke, if it fails to touch either one. Adjust by varying the number of shims between the stop magnet core and the yoke.

260. START MAGNET BRACKET (Figure 103)

With the start magnet armature held operated and the stop magnet armature held so that its inner edge aligns with the outer shoulder on the start magnet armature, there should be from .004" to .008" clearance between the end of the stop magnet armature and the start magnet armature. To adjust, position the stop magnet bracket by means of its mounting screws.

261. STOP MAGNET BRACKET (Figure 104)

With the stop magnet armature held in the operated position by its latch there should be from .004" to .008" clearance between the stop magnet armature and the outer face of the yoke. To adjust, remove the resistor and position the stop magnet bracket by means of its mounting screws.

262. ARMATURE STOP (Figure 103)

With the stop magnet armature against the armature stop, there should be from .070" to .080" clearance between the stop magnet armature and the outer face of the yoke. Adjust the armature stop by means of its mounting screws.

263. LATCH BACKSTOP SCREW (Figure 105)

With the stop magnet armature held in the operated position by the notch in the start magnet armature, there should be some clearance, not more than .008", between the high part of the latching surface of the latch and the end of the slot in the stop magnet armature. Adjust by means of the latch backstop screw.

264. STOP MAGNET ARMATURE SPRING TENSION (Figure 104)

With the stop magnet armature held operated and the stop magnet armature spring unhooked, hook a 32 oz. scale in the spring eye and pull the spring to its normal position length. It should require from 14 to 16 ozs. Adjust by means of the adjustable spring post.

265. START MAGNET ARMATURE SPRING TENSION (Figure 104)

With the stop magnet armature held against

its pole faces, hook an 8 oz. scale over the end of the spring post on the start magnet armature and pull horizontally in line with the spring. It should require from 3-1/2 to 4-1/2 ozs. to start the armature moving.

266. LATCH SPRING TENSION (Figure 103)

With both armatures released, hook an 8 oz. scale over the latch between the spring and the shoulder and pull horizontally. It should require from 1-1/2 to 2-1/2 ozs. to start the latch moving.

267. INNER CONTACT ASSEMBLY (Figure 105)

a. With the stop magnet armature held in the operated position by the notch in the start magnet armature, hook an 8 oz. scale over the spring alongside of the insulator and pull at right angle to the spring. It should require from 1-1/2 to 2 ozs. to start the long spring moving away from the stop magnet armature. To adjust, remove the outer contact assembly, if necessary, and bend the long contact spring.

b. With the stop magnet armature held in the operated position by the notch in the start magnet armature, there should be a gap of from .015" to .020" between the contacts. To adjust, bend the short contact spring.

268. OUTER CONTACT ASSEMBLY

NOTE

The stop magnet armature should be held operated by the notch in the start magnet armature during each of the following adjustments:

a. The two short contact springs nearest the armature should bear against their stiffeners with perceptible pressure when the other springs are held off. Adjust by bending the short contact springs.

b. There should be some clearance, not more than .006" between the insulator on the long contact spring and the stop magnet armature (See Figure 106). Adjust by bending the spring stiffener nearest the armature. Recheck (a).

c. With an 8 oz. scale hooked over the long contact springs at the contact point and pulled at right angle to the springs, it should require from 1 to 1-1/2 ozs. to separate the contacts when the adjacent springs are held away. Adjust by bending the long contact springs.

d. The long contact spring farthest from the stop magnet armature should bear lightly against the long contact spring nearest the stop magnet armature. Adjust by bending the long contact spring farthest from the armature. Recheck adjustment c.

e. Hook an 8 oz. scale over the short contact spring farthest from the stop magnet armature at the contact and pull at right angle to the spring. It should require from 1 to 2 ozs. to start the spring moving away from its stiffener. There should be a gap of from .015" to .020" between the contacts farthest from the armature. Adjust by bending the short contact spring and stiffener. Recheck b. (See Figure 106)

HORIZONTAL TABULATOR MECHANISM ADJUSTMENTS

269. TABULATOR BAR (Figure 107)

a. The tabulator bar should be parallel to the front carriage rail, within .010", as gauged by measuring the clearance between the tip of the tabulator pawl on the carriage and the tabulator stops located at each end of the tabulator bar, and should be centrally located on the send-receive mechanism plate. On units equipped with the 114239 contact assembly in place of the standard send-receive-break key, there should also be .030" to .060" clearance between the left edge of the tabulator bar extension and the contact lever bracket on the base. The tabulator bar should have some end play, not more than .004".

b. The parallel position of the tabulator bar with relation to the front carriage rail may be adjusted by means of the right hand pivot bushing. The end play and the central location of the tabulator bar (clearance between tabulator bar extension and control lever bracket on units equipped with 114239 contact assembly) may be adjusted by means of the pivot screws.

NOTE

With the typing unit resting on its left side, the tabulator bar should clear the supporting surface on which the typing unit is then resting by at least 1/16". Reposition the pivot screws if necessary to secure this clearance.

270. CONTACT LEVER SCREW (Applies only to units equipped with the 114239 contact assembly).

a. With the tabulator latch bar (Figure 109) in its upper position and the send-receive lever (if present) in the SEND position, there should be some clearance, not more than .008", between the adjusting screw on the contact lever and the tabulator bar extension when the arm of the contact lever is touching the insulator of the long contact spring. To adjust, position the contact lever adjusting screw with its lock nut loosened. Recheck after tightening the lock nut.

b. Recheck the send-receive-break mechanism RESET LEVER UPPER ADJUSTING SCREW - paragraph 167.

271. TABULATOR LATCH (Figure 108A)

a. The top of the front projection of the tabulator latch bar should just touch the top of the opening in the tabulator latch, and there should be .010" to .015" clearance between the rear side of the front projection of the tabulator latch bar and the rear wall of the opening in the tabulator latch under the following conditions.

b. With the typing unit resting on its back and the platen in the LETTERS position, select the tabulator combinations and rotate the main shaft until the tabulator function lever rests against the sixth vane. Move the type bar carriage to approximately the center of its travel and back it in position by operating the dash-pot lever. Position one of the tabulator stops so that the point of the stop is opposite to and meets the point of the pawl on the carriage (Figure 108B). See that the tabulator latch bar is in contact with the lobe of the tabulator function lever and gauge for the specified requirements. To adjust, position the tabulator latch by means of its elongated mounting slot.

272. TABULATOR LATCH BAR EXTENSION.

With the printing bail in its extreme rear position, the tabulator bar unlatched, and the rear spacing escapement pawl resting against the low part of the spacing escapement ratchet, the spacing pawl post should meet the bottom of the slot in the spacing pawl link (see figure 109 for location of parts). Adjust by means of the latch bar extension eccentric and mounting screws.

273. TABULATOR STOPS (Figure 108C)

a. The tabulator stops should be adjusted with the typing unit resting on its back or in the normal upright position and may be located to stop the carriage at any desired position.

b. With the carriage in position for the first character of a tabulated column and the spacing escapement ratchet stopped by the rear spacing escapement pawl, position a tabulator stop to the left of the carriage pawl, allowing .008" to .015" clearance between the stop and the pawl, when the tabulator bar end play has been taken up to make the clearance a maximum. Tighten the tabulator stop clamping screw.

c. Locate the large stop at the extreme right end of the line so that the carriage pawl just rides up on the high part of the stop when the carriage reaches the end of its travel.

NOTE

When forms are employed in the machine, the setting of the tabulator stops should be checked, using the form. It is essential that, on all machines connected to the circuit, the stops are set at exactly the same points in terms of the manual spacing operations from its left margin.

274. TRANSMITTER DISTRIBUTOR CONTROL CONTACT (Applies only to units equipped with the 114239 contact assembly).

a. The contact springs and their contacts should be in line. To adjust, position the springs with the mounting screws loosened.

b. With the tabulator contact lever extension held firmly against the mounting bracket, there should be some clearance, not more than .008", between the insulator on the lower end of the long contact spring and the tabulator contact lever extension. To adjust, bend the short contact spring.

c. With an 8 oz. scale hooked over the long contact spring just below the contact, pull horizontally toward the left. It should require 1 to 2 ozs. to just break the contacts. To adjust, bend the long contact spring.

275. TABULATOR FUNCTION LEVER SPRING (Figure 109A)

With the typing unit resting on its right side and the printing bail in its extreme rear position, hook a 12 lb. scale over the rear extension of the tabulator function lever, just in front of the lobe, and pull at right angles to the function lever extension. It should require 3-1/4 to 4-3/4 lbs. to start the function lever moving.

276. TABULATOR LATCH BAR SPRING (Figure 109A)

With the typing unit resting on its right side and the printing bail in its extreme rear position, lift the rear spacing escapement pawl sufficiently to bring the high part of a tooth to the escapement ratchet under the rear escapement pawl and allow the pawl to rest on a ratchet tooth. With the tabulator bar so held that the tabulator latch bar is free of the tabulator latch, hook an 8 oz. scale over the tabulator latch bar, just to the rear of the tabulator latch bar spring, and pull at right angles to the tabulator latch bar. It should require 1-1/2 to 3 ozs. to start the tabulator latch bar moving.

277. TABULATOR BAR SPRING (Figure 109B)

With the typing unit resting on its right side, the printing bail in its extreme rear position, and the tabulator latch bar in its uppermost position, hook a 32 oz. scale on the tabulator bar at the spring hole and pull in line with the tabulator bar spring. It should require 10 to 14 ozs. to start the tabulator bar moving.

NOTE

This tension is 14 to 18 ozs. on units equipped with a transmitter distributor control from tabulator mechanism.

278. FRONT SPACING ESCAPEMENT PAWL (Applies only to units equipped with an adjustable front spacing escapement pawl).

Rotate the main shaft until the printing bail is in its rearmost position. Disengage the rear spacing escapement pawl from the spacing escapement ratchet and rotate the ratchet assembly until a ratchet tooth is in line with the toe on the front spacing escapement pawl extension. Under these conditions, there should be .040" to .060" clearance between the top of the ratchet tooth and the toe of the extension. To adjust, position the extension with its clamping screw loosened.

SWITCH CUT-IN AND AUTOMATIC CUT-OUT OF HORIZONTAL TABULATION

279. SPACING STOP LEVER BRACKET See note (A) on Page 1-3.

The lower end of the spacing stop lever should clear the driving disk of the mainshaft by .060" to .080". With the spacing stop lever held against the stop on the bracket by means

of its spring, there should be a clearance of .040" to .080" between the lower edge of the stop lever and the right side of a tooth on the spacing stop sleeve when the tooth is opposite the lever. Adjust the spacing stop lever bracket vertically by means of its enlarged mounting holes to meet the first requirement and adjust it horizontally to meet the latter requirement. Also adjust it so that the blocking lever is approximately horizontal. Tighten the mounting screws. Make certain that the lever extension clears the tabulator vertical link.

280. BLOCKING LEVER EXTENSION BRACKET - See Note (A) on Page 1-3.

a. Disconnect the tabulator bar spring to prevent latching. With the printing bail in its extreme rear position, lower the blocking lever extension until it rests lightly on the 86773 space pawl link, then tighten the screws. Select the tabulate character; manually rotate the main shaft until the printing bail is in its extreme forward position and see that the blocking lever extension is in its extreme rear (unoperated) position. Observe the vertical alignment of the front surfaces of the extension and the link. The front surface of the link should be at least as far forward as the front surface of the extension bracket but should not extend beyond it by more than 1/4 the thickness of the bracket. To adjust, add or remove washers between the extension and the blocking lever.

b. With the tabulate character selected and the printing bail in its extreme forward position, there should be .008" to .020" clearance between the top of the tabulator latch bar and the tabulator latch in the unlatched position. To adjust, loosen the blocking lever extension screws, raise or lower the extension (keeping it approximately horizontal), and tighten the screws securely.

281. MAGNET BRACKET POSITION - See Note (A) on Page 1-3.

With the magnet energized, the armature and its loosely linked lever should be approximately parallel. Depress the front of the tabulator latch bar thereby causing the vertical link to rise. There should be some clearance, not more than .015" at the closest point, between the front rear surfaces of the forked top of the vertical link and the blocking lever extension. To adjust, position the 122364 magnet angle bracket on its mounting plate and tighten the mounting screw that does not secure the 122365 plate.

282. SIGNAL BELL HAMMER BACKSTOP - See Note (A) on Page 1-3.

Apply standard adjusting procedure as prescribed in paragraph 135. The last sentence of the adjustment should read: "To adjust, position the 122365 plate and, in so doing, be careful not to shift the magnet angle bracket. Tighten the mounting screw."

283. LOCKING CONTACT - See Note (A) on Page 1-3.

NOTE

The contact bracket mounting holes are oversize in order that the entire contact assembly may be shifted if necessary.

a. With the magnet de-energized, hook an 8 oz. scale behind the insulator on the long contact spring and pull at a right angle to the spring. It should require 1 to 2-1/2 ozs. to start the contact spring moving away from the blocking lever. To adjust, bend the long contact spring.

b. With the magnet de-energized, hook an 8 oz. scale behind the short contact spring just above the contact and pull at a right angle to the spring. It should require 3 to 6 ozs. to start the contact spring moving away from its stiffener. To adjust, bend the short contact spring.

c. With the magnet energized, there should be at least .003" clearance between the short contact spring and its stiffener. With the magnet de-energized, there should be a gap of at least .025" between the contacts. To adjust, bend the stiffener. Recheck preceding paragraph (b).

NOTE

If the .003" requirement cannot be met, increase the armature travel by refining the magnet bracket position adjustment. Replace the signal bell.

284. SPACING STOP LEVER SPRING TENSION - See Note (A) on Page 1-3.

Apply standard adjusting procedure as prescribed in paragraph 151.

285. BLOCKING LEVER SPRING TENSION - See Note (A) on Page 1-3.

Hold the long contact spring away from the blocking lever. Hook an 8 oz. scale on the lever

near the spring hole and pull at a right angle to the lever. It should require 1 to 2 ozs. to start the lever moving.

REPLACE THE TYPE BAR CARRIAGE

286. RIGHT MARGIN ADJUSTING SCREW

Apply standard adjusting procedure as prescribed in paragraph 169. If the margin screw does not fully engage the spacing stop lever, reposition the margin screw arm detent on the carriage by means of its oversize holes, and make certain that the screw still clears the side frame as the carriage moves.

REPERFORATOR MOTOR CONTROL MECHANISM ADJUSTMENTS

287. REPERFORATOR CONTROL PLATE (Figure 110 and 111)

With the BLANK combination selected and the main shaft rotated until the function levers rest against the vanes, there should be some clearance, not more than .008", between the horizontal arm of the contact pawl and its function lever when the contact pawl is in the lower notch of its latch. There should also be some clearance, not more than .008", between the horizontal arm of the contact pawl latch and its function lever when the contact pawl is in the upper notch of its latch. To adjust, position the reperforator control plate with its mounting screws loosened.

288. REPERFORATOR CONTROL CONTACT (Figure 110)

a. With the horizontal arm of the contact pawl in its upper position, there should be some clearance, not more than .008", between the insulator on the lower contact spring and the contact pawl. To adjust bend the upper (heavy) contact spring.

b. Hook an 8 oz. scale over the contact spring at the contact, and pull vertically downward. It should require 3 to 4 ozs. to open the contacts. To adjust, bend the lower (light) contact spring.

289. CONTACT PAWL SPRING TENSION (Figure 110)

With the horizontal arm of the contact pawl in its upper position and the contact spring held clear of the contact pawl, apply the push end of an 8 oz. scale at the right end of the

horizontal portion of the pawl and push outward. It should require 1-1/2 to 3 ozs. to start the pawl moving.

290. REPERFORATOR CONTROL FUNCTION LEVERS SPRING TENSIONS (Figure 111)

Select the BLANK combination and rotate the main shaft until the function levers rest against the vanes. Hook a 32 oz. scale under the forward extension of the function lever in slot No. 13, just to the rear of the lobe, and pull upward. It should require 24 to 32 ozs. to start the lever moving. Check the spring tension on the function lever in slot No. 6 in the same manner.

AUTOMATIC CARRIAGE RETURN AND LINE FEED ADJUSTMENTS

NOTE

On units equipped with the stop bracket (Figure 113), if carriage return only is desired upon receipt of the carriage return selection, remove the stop bracket. The first two adjustments apply only to units equipped with this bracket.

291. CARRIAGE RETURN LATCH - BAR LATCH SHIMS (Figure 114)

a. Remove the spring of the automatic carriage return and line feed function lever. (Figure 118)

b. Set the typing unit on its left side. Rotate the carriage return function lever eccentric so that the high part of the eccentric is away from the casting. With the letter O combination (-, -, -, 4, 5) selected and the main shaft rotated until the printing bail is in its extreme forward position, there should be .004" to .010" clearance between the carriage return latch bar and the lobe on the carriage return extension of the bail assembly. When checking this clearance, the shoulder on the carriage return latch bar should be fully latched on the latch. To adjust, add or remove shims between the carriage return latch-bar latch and the function lever comb.

292. CARRIAGE RETURN FUNCTION LEVER ECCENTRIC SCREW (Figure 114)

a. With the letter O combination (-, -, -, 4, 5) selected and the main shaft rotated until the printing bail is in its extreme forward position, there should be .004" to .010" clearance between the carriage return latch bar and the extension

on the carriage return function lever. When checking this clearance, the shoulder on the carriage return latch bar should be fully latched on the latch. To adjust, position the carriage return function lever eccentric mountingscrew. Tighten the nut.

b. Recheck 277. b.

c. Replace the automatic carriage return and line feed function lever spring.

293. OPERATING BAIL LINE FEED EXTENSION (Figures 115 and 116)

a. With the printing bail in its extreme rear position and the automatic carriage return trigger held in its operated position, rotate the main shaft until the automatic carriage return and line feed function lever just touches the number one vane. There should be some clearance, not more than .010" between the line feed push bar and the bottom of the function bail blade. To adjust, position the line feed extension by means of its enlarged mounting holes. Reposition the function bail blade if necessary.

b. To check the function bail blade adjustment, select the combination for the letter "O" (-,-,4,5) when the printing bail is in its rear-most position, then rotate the main shaft until the printing bail is in its extreme forward position. There should be some clearance between the upper edge of the line feed extension projection of the bail and the lower edge of the line feed push bar.

294. AUTOMATIC CARRIAGE RETURN AND LINE FEED FUNCTION LEVER ECCENTRIC SCREW (Figure 114)

a. There should be an equal amount of clearance (within .010") between the bottom edge of the carriage return latch bar and the latch bar latch when, first the carriage return function lever is fully selected and then the automatic carriage return and line feed function lever is fully operated. To adjust, position the automatic carriage return and line feed function lever eccentric screw.

295. MOUNTING BRACKET (Figure 117)

NOTE

If the shift-blank-stop motor control mechanism is not used on the typing unit on which the automatic carriage return and line feed mechanism is installed, subsequent references to the

motor stop function lever blocking lever may be ignored.

a. With the trigger guide positioned in approximately the middle of its adjustable range, adjust the mounting bracket (a) approximately parallel to the 74019 spring plate, and (b) so that there is some but not more than .002" clearance between the front edge of the motor stop function lever and the blocking end of the blocking lever when the space combination is selected and the main shaft is rotated until the function lever rests against the vanes.

b. With the "Figure H" combination selected and the motor stop function lever blocked by its blocking lever, the motor stop function lever should not block the travel of the printing bail.

296. TRIGGER GUIDE (Figures 114 and 118)

a. With the letter "O" combination (-,-,4,5) selected and the main shaft rotated until the printing bail is in its extreme forward position, there should be some clearance, not more than .010" between the carriage return latch bar and the lobe on the carriage return extension of the bail assembly. To adjust, position the trigger guide by means of its elongated mounting holes.

b. Check: With the main shaft in the stop position, there should be at least .005" clearance between the blocking edge of the trigger extension and the front edge of the automatic carriage return and line feed function lever, when the play is taken up to make this clearance a minimum.

297. TRIGGER ADJUSTABLE SCREW (Figure 118)

a. The automatic carriage return and line feed mechanism is designed to operate on a 72 to 76 character range. To check this adjustment, space the carriage one less than the desired number of characters on the line. There should be a clearance of .006" to .020" between the left-hand edge of the trigger extension and the right-hand edge of the blocking extension on the automatic carriage return and line feed function lever when the play in the function lever is taken up to the left. To adjust for this clearance, loosen the lock nut of the trigger adjustable screw and position the screw. Tighten the lock nut.

298. CARRIAGE RETURN AND AUTOMATIC CARRIAGE RETURN AND LINE FEED FUNCTION LEVER SPRING TENSIONS (Figure 118)

a. CARRIAGE RETURN

With the carriage return combination fully selected and with the carriage return function lever resting against the vanes, unhook the carriage return function lever spring from the spring plate. Insert the hook end of a 12 lb. scale into the free end of the spring. It should require 9 to 11 lbs. to stretch the spring to its position length. Rehook the spring.

b. AUTOMATIC CARRIAGE RETURN AND LINE FEED FUNCTION LEVER

Measure the tension of the automatic carriage return and line feed function lever spring in a similar manner, with the function lever unblocked and resting against the vanes.

299. TRIGGER SPRING TENSION (Figure 118)

a. Hook an 8 oz. scale over the trigger at the spring hole and pull horizontally in line with the spring. It should require a pull of 3-1/2 to 5 ozs. to just start the trigger moving.

300. BELL CRANK RETAINER YIELD LEVER SPRING TENSION (Figure 112)

a. Hook a 32 oz. scale over the end of the yield lever and pull horizontally in line with the spring. It should require 24 to 32 ozs. to start the arm moving.

301. LINE FEED LINK TURNBUCKLE. See paragraph 109.

TWO-COLOR RIBBON CONTROL ADJUSTMENTS

NOTE

All the following adjustments apply to the function lever controlled mechanism. Adjustments 296 through 301 inclusive do not apply to the manually controlled mechanism.

302. RIBBON OSCILLATOR LEVER (Figure 119) - Replaces standard RIBBON OSCILLATOR LEVER ADJUSTMENT, paragraph 170.

Select any character which prints and turn the printer main shaft until the printing bail is in its extreme forward position. Then with the platen in the upper position and the ribbon oscillator lever toward the front of the printer (not held by its latch), make certain that the

ribbon oscillator is not resting against the ribbon oscillator lever adjustable stop. If necessary, loosen the screws and move the adjustable stop out of the way. (Adjustable stop is shown in Figure 121.) Manually place the ribbon oscillator lever in its latched position. Then, with the comma type pallet pushed tightly against the black-red record ribbon to make an imprint of the comma, there should be some clearance, not more than .025", between the bottom edge of the imprint made by the comma and the top edge of the red portion of the ribbon. To adjust, place the platen in the shift position (up). Then loosen the ribbon oscillator lever clamping screw and nut, and position the ribbon oscillator lever by means of its slotted hole. Tighten the clamping screw and nut.

303. RIBBON OSCILLATOR LEVER LATCH BRACKET (Figure 120) See Note (A) on Page 1-3.

With the ribbon oscillator lever held to the rear of the type basket so that it just touches either the carriage frame casting or the lock nut for the upper carriage track roller, there should be at least .030" clearance between the latch and the ribbon oscillator lever. To adjust, loosen the latch bracket mounting screws and position the latch bracket by means of its elongated mounting holes. Tighten the mounting screws.

304. RIBBON OSCILLATOR LATCH SPRING TENSION (Figure 120) See Note (A) on Page 1-3.

With the ribbon oscillator lever held away from its latch, hook an 8 oz. scale over the latch where the spring is hooked and pull in line with the spring. It should require a pull of 1/2 to 2 ozs. to just start the latch moving.

305. RIBBON OSCILLATOR LEVER ADJUSTABLE STOP (Figure 121) See Note (A) on Page 1-3.

With the pull bar bail plunger held so that there is .010" to .050" clearance between the pull bars and the code bars, the ribbon oscillator lever should overtravel the latching surface of the latch .012" to .020". To adjust, loosen the adjustable stop mounting screw and position the adjustable stop by means of its elongated mounting hole. Tighten the mounting screw.

306. PARALLELOGRAM BAR BRACKETS (See Figure 122 for location of parts) See Note (A) on Page 1-3.

With the magnet de-energized and with the armature backstop eccentric positioned to give maximum travel of the armature, the front edge of the parallelogram bar should be parallel with the front edge of the upper track and its front edge should not project beyond the front edge of the upper track by more than .030". To adjust, loosen the right bracket and the magnet bracket mounting screws and position the bracket by means of their large mounting holes. Tighten the mounting screws. When checking this requirement any play in the parts should be taken up by holding parallelogram to the rear.

REPLACE THE TYPE BAR CARRIAGE

NOTE

Check the "RIBBON OSCILLATOR LEVER ADJUSTABLE STOP" adjustment of .012" to .020" overtravel with the main shaft in the stop position and the platen in the LETTERS position. There should also be at least .006" clearance between the oscillator lever and either the carriage frame casting or the lock nut for the upper carriage track roller, whichever is the closest. If necessary, refine the "RIBBON OSCILLATOR LEVER ADJUSTABLE STOP" adjustment.

307. MAGNET YOKE (Figures 122 and 123)

a. With the magnet armature held against the core of the magnet, there should be .010" to .020" clearance between the end of the yoke and the magnet armature. Adjust by adding or removing shims between the magnet core and the yoke.

b. The above clearance should not vary between the two ends of the yoke by more than .010". To obtain this adjustment, tilt yoke by adding or removing shims between the yoke and the magnet bracket. Recheck a.

c. With the armature held against the core of the magnet, the ribbon oscillator lever should clear the latch by .008" to .020". To adjust, loosen the magnet yoke mounting screws and position the magnet yoke by means of the elongated holes in the magnet bracket. Before tightening the screws, be sure that the ends of the yoke are parallel with the armature. Check this clearance with the type bar carriage at both ends of the typing unit. Tighten the mounting screws.

308. ARMATURE ECCENTRIC BACKSTOP (Figure 124)

Select any character that prints and rotate the main shaft until the printing bail is in its extreme forward position. With the ribbon oscillator lever in its unlatched position, and the magnet armature in its unoperated position, resting against the eccentric backstop, there should be some clearance, not more than .015", between the rear surface of the ribbon oscillator lever latch projection and the front edge of the parallelogram bar. With the parallelogram bar so held as to make this clearance a maximum, check this clearance with the type bar carriage at both ends of the typing unit. To adjust, loosen the eccentric backstop mounting screw and position the eccentric. Tighten the mounting screw.

309. ARMATURE SPRING TENSION (Figure 124)

Unhook the armature spring, check magnet armature and parallelogram bar for binds. Replace the spring. Apply the push end of a 8 oz. scale to the armature just above the armature mounting screws. It should require 1 to 3 ozs. to start the armature moving.

310. CONTACT OPERATING LEVER BRACKET (Figure 125A)

With the contact operating lever in its latched position and the two-color operating function levers resting against the selector vanes, but not selected, there should be .004" to .020" between the latch extension and the No. 5 function lever extension. To adjust, loosen the contact operating lever bracket mounting screws and position the bracket by means of its elongated hole. Tighten the mounting screws.

311. CONTACT SPRINGS (Figure 125B)

CAUTION

Turn the motor power switch to "OFF" position when checking this adjustment.

a. With the pull end of an 8 oz. scale hooked over the short contact spring, near the contact point, it should require a tension of 3 to 4 ozs. to start the spring moving away from the stiffener when the contact operating lever clears the bakelite tip on the long contact spring. To adjust, remove the spring from the assembly and bend.

b. There should be a clearance of .015" to .025" between the contact points of the short and long contact springs when the contact operating lever clears the bakelite tip on the long contact spring. To adjust, bend the long contact spring.

c. With the contact operating lever in its latched position (Figure 126B) there should be some clearance, not more than .010" between the short contact spring and the contact spring stiffener at its extreme end. To adjust, loosen the contact bracket mounting screws and position the contact bracket horizontally by means of its elongated mounting holes. Tighten the mounting screws.

312. LINK (Figure 125C)

With the function lever, which shifts the ribbon to "Red" (in position No. 6 or No. 7) in its operated position, the contact operating lever should overtravel its latch by .004" to .015". To adjust, set up the No. 6 (or 7) function lever code combination and rotate the printer main shaft until the No. 6 (or 7) function lever is in its fully operated position. Loosen the link mounting screw and position the contact operating lever by means of its elongated hole, with the bottom of the link slot held against the bottom edge of the No. 6 (or 7) function lever. Tighten the link mounting screw.

313. CONTACT OPERATING LEVER SPRING TENSION (Figure 125A)

With the contact operating lever in its latched position, unhook the contact operating lever spring from the contact operating lever. With an 8 oz. scale hooked in the spring eye, it should require 2 to 4-1/2 ozs. to pull the spring to position length.

314. TWO-COLOR MECHANISM NO. 5 AND NO. 6 FUNCTION LEVER SPRING TENSIONS (Figure 125A)

With the function levers resting against the selector vanes but not selected, hook a 32 oz. scale over the bottom of the function lever extension and pull upward. It should require 24 to 32 ozs. to start each function lever moving.

NOTE

The following two adjustments apply only to sprocket feed printers.

315. LOADING PLATE

Bend the front edge of the loading plate upward slightly to overcome interference between it and the ribbon carrier.

316. TYPE BAR GUIDE

Bend the type bar guide forward approximately .025" so as to provide clearance between the ribbon carrier and the sprocket pins.

NOTE

When the two color ribbon control mechanism is installed in the field on units equipped with the reperforator control mechanism, the following adjustment should be remade.

Send-Receive-Break Mechanism Plate - Paragraph 163.

Reperforator Control Plate - Paragraph 286.

Reperforator Control Contact - Paragraph 287.

Contact Pawl Spring Tension - Paragraph 288.

Reperforator Control Function Levers Spring Tensions - Paragraph 289.

Blocking Bail Plate - Paragraph 47.

MECHANICAL WORD COUNTER ADJUSTMENTS

317. STAR WHEEL TANGENTIAL TENSION (Figure 151)

NOTE

Usually this adjustment is not required for new style counters which have the retaining ring. However, if the 3 to 7 oz. tangential tension cannot be met due to variations in the retaining ring slot position, it may be necessary to add shims between the retaining ring and washer (when adding shims, be sure that the shims are clear of the retaining ring slot so that the retaining ring may be reinstalled properly).

Rotate the star wheel at least 1/4 turn after a number has just been registered on the counter and so that one side of a tooth on the star wheel is vertical. Hook an 8 oz. scale over the vertical face of this tooth, approximately 1/16", and pull horizontally. It should require 3 to 7 ozs. to start the star wheel rotating. To adjust, position the star wheel either toward or away from the star wheel bearing by means of its set screws.

318. COUNTER ASSEMBLY POSITION

The counter assembly should be positioned so that the pins in the slide lever properly engage the teeth on the star wheel and so that the end of the star wheel does not bear against the slide lever.

a. To adjust, loosen the counter mounting screws. Then turn the typing unit main shaft until the printing bail is rotated to the extreme forward position. The slide lever should be stopped against the spring post in the counter mounting bracket; the lower pin in the slide lever will then position the star wheel for the following adjustment. This condition may be attained by pushing the slide lever downward and allowing its spring to return it quickly. Operate the slide lever slowly by hand and position the counter away from or toward the typing unit (looking at the side of the typing unit) so that the upper pin in the slide lever engages a tooth on the star wheel approximately midway between its peak and bottom.

b. With the play in the slide lever and the counter shaft taken up so that the clearance between the end of the star wheel and the slide lever will be a minimum, position the counter so that there is some clearance, but not more than .025" between the slide lever and star wheel. Tighten the counter mounting screws and recheck a.

319. OPERATING LINKAGE

a. Rotate the main shaft until the printing bail is in its extreme rear position. Adjust the operating linkage by means of the eccentric shoulder screw in the end of the operating lever so that the upper pin in the slide lever just bottoms between two teeth on the star wheel and so that, with the upper slide lever pin in this position, the star wheel will have a barely perceptible amount of backlash. Check for this backlash during a complete revolution of the star wheel. If this adjustment cannot be made by means of the eccentric shoulder screw in the operating lever, adjust this shoulder screw to its most favorable position and adjust the eccentric spring post in the bell crank to meet this requirement.

b. If this adjustment cannot be met with both eccentrics in their most favorable position, vary the height of the counter mounting bracket by shifting the bracket in its large mounting holes. Then recheck paragraph 318. b.

320. SLIDE LEVER SPRING TENSION

With the printer on its left side, unhook the bottom of the slide lever spring. Hook a 64 oz. scale in the spring eye and pull in line with the slide lever. It should require from 34 to 42 ozs. to stretch the spring to position length when the printing bail is in its rearmost position.

321. LINK YIELD SPRING TENSION

Unhook the link yield spring from the link arm and hook a 64 oz. scale in the spring eye

and pull in line with the link. It should require from 54 to 64 ozs. to stretch the spring to position length.

ELECTRICAL WORK AND OPERATIONS COUNTER ADJUSTMENTS

322. STAR WHEEL TANGENTIAL TENSION

This adjustment is made before installation of the Word Counter.

Loosen the cover mounting screw and remove the cover from the contact assembly. Rotate the star wheel until the contact spring operation screw (which also secures the star wheel to its shaft) points downward and so that one side of a tooth on the star wheel is vertical. Hook an 8 oz. scale over the vertical face of this tooth approximately 1/16" and pull horizontally. It should require from 4 to 6 ozs. to start the star wheel rotating. To adjust, position the star wheel either toward or away from the star wheel bearing, by means of its set screw.

322.1 OPERATING LEVER POSITION

When it is required that the counter register on all printing and spacing operations only, position the operating lever so that it pivots about its outer mounting screw hole. When it is required that the counter register on all printing, spacing, and functional operation, position the operating lever so that it pivots about its inner mounting screw hole.

323. CONTACT REQUIREMENTS

a. For operation of the contacts on every printing, spacing and functional operation of the printer, the following requirements should be met:

(1) There should be .050" to .055" clearance between the insulator on the lower contact spring and the peak of a tooth on the star wheel. To adjust, bend the lower contact spring.

(2) There should be .015" to .025" clearance between the contacts when the slide lever is held down against its stop. To adjust, bend the upper contact spring.

b. For operation of the contact on every sixth printing, spacing and functional operation of the printer, the following requirements should be met:

(1) There should be .050" to .055" clearance between the insulator on the lower contact spring and the peak of a tooth on the star wheel. To adjust, bend the lower contact spring.

(2) There should be .015" to .025" clearance between the contacts when the pin in the star

wheel is pointing downward. To adjust, bend the upper contact spring.

324. CONTACT AND BRACKET ASSEMBLY ADJUSTMENT

The star wheel bearing should be positioned to left or right so that the pins in the slide lever properly engage the teeth on the star wheel, and to front or rear so that the star wheel does not bear against the slide lever.

a. To adjust, loosen the star wheel bearing mounting screws. Then rotate the typing unit main shaft until the printing bail moves to the extreme forward position. The slide lever should be stopped against the spring post in the contact mounting bracket; the lower pin in the slide lever will then position the star wheel by the following adjustment. This condition may be attained by pushing the slide lever downward and allowing its spring to return it quickly. Operate the slide lever slowly by hand and position the star wheel bearing away from or toward the typing unit (looking at the side of the typing unit) so that the upper pin in the slide lever engages a tooth on the star wheel approximately midway between its peak and bottom.

b. With the play in the slide lever and the star wheel shaft taken up so that the clearance between the end of the star wheel and the slide lever is a minimum, position the star wheel bearing so that there is some clearance, not more than .025" between the slide lever and the star wheel. Tighten the star wheel bearing mounting screws and recheck a.

325. OPERATING LINKAGE - Same as paragraph 319 except recheck paragraph 324. b. instead of 318.
326. SLIDE LEVER SPRING TENSION - Same as paragraph 320.
327. LINK YIELD SPRING TENSION - Same as paragraph 321.

FEEDING FOUR LINES PER INCH ADJUSTMENTS

328. LINE FEED LINK TURNBUCKLE

a. With the SINGLE-DOUBLE line feed lever in the DOUBLE line feed position, select the line feed combination and rotate the main shaft until:

(1) On units not equipped with automatic carriage return and line feed, the line feed push bar is being stripped from the function bail blade.

(2) On units equipped with automatic carriage return and line feed, the function bail is in its extreme rear position.

b. Under this condition, the turnbuckle should be adjusted so that the platen has rotated two line-spaces, that the detent roller rests in the hollow between two ratchet teeth and that the feed pawl is still in engagement with a ratchet tooth to such an extent that there is no clearance or not more than .002" clearance between the detent roller and the detenting face of the tooth just above the roller. Check for this condition at 4 positions on the ratchet approximately 90° apart.

329. LINE FEED CHECK SCREW

The line feed check screw should drop in the 8th notch from the detent roller. (When counting the notches, start with the notch just above the detent roller.) There should be some clearance, not more than .020", between the front face of the screw and the face of the tooth, at the point of minimum clearance, when the check screw is held in the bottom of a notch on the ratchet. To adjust, loosen the line feed check screw lock nut and position the check screw to meet the foregoing requirements. Tighten the lock nut. Rotate the platen roll and check the clearance in each notch of the ratchet. If necessary, loosen the clamping nut of the line feed check post stop screw and back off the stop screw before making this adjustment.

END OF LINE PRINTING AND SPACING ADJUSTMENTS

330. PRINTING AND SPACING CUTOUT MECHANISM BRACKET (Figure 126) See Note (A) on Page 1-3.

There should be a .020" to .040" clearance between the spacing stop lever and the side of a projection on the spacing stop sleeve. To adjust, loosen the printing and spacing cutout mechanism bracket mounting screws and position the bracket horizontally by means of its elongated mounting holes; tighten the mounting screws.

331. PRINTING CUTOUT LATCH ECCENTRIC BUSHING (Figure 127) See Note (A) on Page 1-3.

Set up the FIGURES combination on the vanes and rotate the main shaft until the function lever bail rests on the shift function lever. Push the printing bail toward the rear of the typing unit manually and raise the printing cutout latch into engagement with the rear blade of the printing bail. With the printing bail held by the latch, there should be some clearance, not more

than .015", between the blocking arm of the shift function lever and the blocking surface of the blocking plate. To make this adjustment, first position the eccentric so that the high part is toward the rear of the typing unit, then rotate the eccentric counterclockwise.

NOTE

After the foregoing adjustment has been made, there should be some clearance between the front end of the printing cutout latch and the front blade of the printing bail (Figure 128A), when the main shaft is rotated until the printing bail is in its extreme rear position and the printing cutout latch is raised by hand.

REPLACE THE TYPE BAR CARRIAGE

332. RIGHT MARGIN ADJUSTING SCREW (Figure 128B)

With the printing bail in the extreme rear position and the type bar carriage one space to the right of that in which the last character is to be printed, push the spacing stop sleeve projection backward just enough to permit the spacing stop lever to pass in front of the projection. There should then be .010" to .020" clearance between the printing cutout latch and the lower edge of the rear printing bail blade. To adjust, position the right margin adjusting screw.

333. PRINTING CUTOUT LATCH DOWN-STOP ECCENTRIC (Figure 129)

With the printing bail in its extreme forward position, there should be .008" to .015" clearance between the lower edge of the rear printing bail blade and the printing cutout latch. To make this adjustment, first position the eccentric so that the high part is toward the rear of the typing unit, then rotate the eccentric counterclockwise.

334. SPACING STOP LEVER SPRING TENSION (Figure 126)

Hook a 32 ounce scale over the upper end of the spacing stop lever and pull horizontally toward the right. It should require 8 to 12 ounces to start the lever moving.

335. PRINTING CUTOUT LATCH SPRING TENSION (Figure 129)

With the printing bail in its extreme forward position, hook an 8 ounce scale under the printing cutout latch, just to the rear of the spring hole and pull upward, as nearly vertically as possible. It should require 1 to 2-1/2 ounces to start the latch moving.

REMOTE SIGNAL BELL CONTACT (WITH LATCH) ADJUSTMENTS

336. CONTACT AND BACKSTOP BRACKET (Figure 130A and 130B)

a. There should be at least .015" clearance between the bracket and the spacing shaft.

b. There should be some clearance, not more than .020", between the side of the contact lever and the side of the bell reset bar, when the play of the contact lever is taken up in a direction to make the clearance a minimum.

c. The adjusting screw on the contact lever latch should meet the rear spacing escapement extension squarely.

d. To adjust, loosen the contact and backstop bracket mounting screws and position the bracket to meet the above requirements. Tighten the mounting screws.

337. CONTACT LEVER LATCH MOUNTING SCREW (Figure 130)

Set the typing unit on its right side. With the platen in the FIGURES position and the BELL combination set up on the vanes, rotate the main shaft until the bell latch bar is moved off its latch. With the contact lever held against the latch bar, there should be a clearance of .008" to .015" between the shoulder nearest the pivot screw of the contact lever latch and the stud on the contact lever. To adjust, position the contact lever latch mounting screw in its elongated mounting hole.

338. UPPER CONTACT SPRING TENSION (Figure 131)

With the bell latch bar in its latched (unoperated) position, the contact lever in its unlatched position, and the lower contact spring held away from the upper contact spring, hook an 8 oz. scale over the end of the insulator on the upper contact spring and pull at right angles to the spring. It should require 1 to 2 ozs. to

start the insulator moving away from the contact lever. To adjust, bend the upper contact spring.

339. LOWER CONTACT SPRING TENSION (Figure 131)

Hook an 8 oz. scale over the lower contact spring at the contact point and pull at right angles to the contact spring. It should require 2-1/2 to 3-1/2 ozs. to start the spring moving away from its stiffener. To adjust, bend the lower contact spring.

340. CONTACT GAP (Figure 131)

With the printing bail in its extreme rear position, and with the contact lever in its unlatched position, there should be .015" to .025" clearance between the contact points. To adjust, bend the lower contact spring stiffener. Recheck LOWER CONTACT SPRING, paragraph 339.

NOTE

When the contacts are closed, there should be some clearance between the lower contact spring and the free end of its stiffener.

341. SIGNAL BELL HAMMER BACKSTOP SCREW (Figure 59)

With the printing bail in its extreme rear position, and the bell latch bar in its latched position, there should be .020" to .040" clearance between the bell hammer arm extension and the bell operating lever. To adjust, position the signal bell hammer backstop screw.

342. CONTACT LEVER LATCH ADJUSTING SCREW (Figure 132)

Set up any printing combination on the vanes and rotate the main shaft until the printing bail is in its extreme forward position. The post on the contact lever should clear the shoulder on the contact lever latch by .010" to .025". To adjust, position the contact lever latch adjusting screw.

343. CONTACT LEVER LATCH SPRING TENSION (Figure 132)

With the printer resting on its right side, and the contact lever in its unlatched position, hook an 8 oz. scale over the upper end of the contact lever latch and pull at right angles to the latch. It should require from 2-1/2 to 3-1/2 ozs. to start the latch moving.

ADJUSTMENTS FOR PRINTERS EQUIPPED FOR STATION SELECTOR OPERATION

TYPING UNIT ADJUSTMENTS

344. CALL-CONTACTS (Figure 133)

a. With the main shaft rotated so that the call-contact function lever is resting against the selector vanes, but not selected, there should be some clearance, not more than .010" between the insulator on the end of the contact spring and the lobe on the call-contact function lever. To adjust, bend the upper contact spring.

b. With the main shaft in the same position as specified in paragraph a. there should be a contact gap of .015" to .020". To adjust, bend the lower contact spring.

345. CALL - CONTACT FUNCTION - LEVER SPRING TENSION (Figure 133)

With the call-contact function lever resting against the vanes, not selected, and the contact spring held away, hook a 32 oz. scale under the extreme front end of the lever and pull vertically upward. It should require a tension of 24 to 32 ozs. to start the function lever moving.

346. TRANSFER CONTACTS (Figure 134)

a. With the transfer contact lever held away from the insulator on the transfer contact spring, the center contact should make with the lower contact. There should also be a clearance of .030" to .040" between the center and upper contacts. To adjust, bend the upper (heavy) contact spring so that it is parallel to and in line with the insulators between which it is mounted. Bend the center contact spring so that it rests against the lower spring with just a slight amount of tension and then bend the lower contact spring to obtain the required gap.

b. With the transfer contact lever held away from the contact insulator, hook an 8 oz. scale under the center contact spring between the insulator and the contact and pull vertically upward. A tension of 3-1/2 ozs. should be required to open the contacts. To adjust, bend the center contact spring. Recheck a.

c. The position of the transfer contacts in relationship to the transfer contact lever should be such that, when the transfer contact lever is in its lower most position, there would be a clearance of .010" to .020" between the end of

the transfer contact lever and the insulator on the center contact spring. To adjust, loosen the screws which secure the transfer contact bracket to the send-receive plate, and position the transfer contact assembly so that the upper and lower contact springs are parallel to the function lever spring plate. Tighten the transfer contact bracket mounting screws. Set up the SPACE combination (front edge of #3 vane down, front edges of #1, #2, #4, and #5 up) and rotate the main shaft until the printing bail is in its extreme forward position. Position the adjusting screw (Figure 135) on the transfer-contact function lever to meet the requirement, and tighten the lock nut.

347. TRANSFER CONTACT - LEVER SPRING TENSION (Figure 135)

Place the typing unit on the right side. With the main shaft in the stop position and the transfer contact held away from the contact lever, hook a 32 oz. scale to the transfer contact lever at the spring hole and pull horizontally in line with the spring. It should require a tension of 12 to 16 ozs. to start the lever moving.

348. TRANSFER CONTACT FUNCTION - LEVER SPRING TENSION (Figure 136)

Place the typing unit on the right side. Select SPACE (#3 vane down) and rotate the main shaft until the printing bail is in its extreme forward position. With the transfer contact lever held away from the adjusting screw head, hook a 64 oz. scale to the transfer-contact function lever extension and pull horizontally. It should require a tension of 20 to 28 ozs. to start the lever moving.

349. FUNCTION LEVER BAIL - See paragraph 46 and 48.

NOTE

A minimum clearance of .025" is permissible between the rear edge of the No. 1 vane and the front edge of the transfer contact function lever when the typing unit is equipped with the station selector mechanism.

350. DISCONNECT CONTACT (Figures 137 and 138)

a. Set up the CARRIAGE-RETURN combination and rotate the main shaft until the printing bail is in its extreme forward position. There

should be a clearance of .010" to .020" between the disconnect contacts. To adjust, bend the stiffener to obtain this clearance.

b. With the main shaft in its STOP position, make certain that there is some clearance between the insulator on the lower disconnect contact spring and the bell crank when the play in the bell crank is taken up in the direction to make this clearance a maximum. To adjust, bend the stiffener and the upper contact spring.

c. With the typing unit resting on the right side and the main shaft in its STOP position, hook an 8 oz. scale to the lower contact spring between the contact and insulator and pull at a right angle to the contact spring. It should require a tension of 3-1/2 to 5 ozs. to just break contact. To adjust, bend the lower contact spring.

KEYBOARD ADJUSTMENTS

351. KEYLEVER LINK (Figure 139)

The keylever link should be positioned on its keylever to provide from .020" to .040" clearance between the vertical edge of the link and the vertical side of the bail. To adjust, loosen the link clamping screw and position the link.

352. BAIL SPRING TENSION (Figure 140)

With the keyboard upside down, hook an 8 oz. scale under the end of the bail spring and pull vertically upward. It should require a tension of 2 to 3 ozs. to start the spring moving away from the bail. To adjust, bend the spring.

353. BAIL BACKSTOP (Figure 139)

There should be some clearance, not more than .004" between the edge of the bail and the hook on the keylever link. To adjust, loosen the bail-backstop eccentric mounting screw. Hold the bail against the eccentric backstop, and turn the eccentric. Tighten the screw.

354. ANSWER - BACK - MAGNET HEEL - PIECE AIR GAP (Figure 141)

There should be a clearance of .005" to .015" between the end of the heel piece and the armature when the armature is held in the operated position. To adjust, loosen the armature-yoke mounting screw and place a .008" gauge between the heel piece and the armature. Hold the armature firmly against the gauge and tighten the mounting screw.

355. BAIL (Figure 139)

The eccentric bushing on the bail which is engaged in the forked end of the answer-back-magnet armature lever should be adjusted to provide full travel of the keylever which it operates. To adjust, loosen the eccentric bushing mounting screw, fully depress the answer-back keylever, place the magnet armature in its operated position, and rotate the eccentric bushing until the bail just clears the keylever link. Tighten the eccentric bushing mounting screw.

NOTE

Adjust the eccentrics so that the keyboard clutch is just tripped when the answer-back magnet is energized with a piece of Teletypewriter copy paper (.003" to .004" thick) placed between the armature and the pole piece. It is important not to increase or decrease this adjustment as intermittent errors may occur.

100 WPM KEYBOARD ADJUSTMENTS

356. TRANSMITTING CONTACT GAP (Figure 142)

With each contact lever on the high part of its cam, the contact gap should be .017" to .025" (.015" to .025" for start-stop contacts) when using a signal measuring device. If no signal measuring device is available, all contact gaps should be .020" to .025". To adjust bend the short contact spring.

357. TRANSMITTING CONTACT SPRING STIFFENER (Figure 142)

With each contact lever on the high part of its cam, apply the push end of an 8 oz. scale to the short contact spring at the contact and push at right angles to the spring. It should require 4 to 8 ozs. to start the short contact spring moving away from its stiffener. To adjust, bend the stiffener. Recheck contact gap, paragraph 356.

358. LOCK LOOP BACKSTOP SCREW (Figure 143)

With the lock loop held against the backstop screw, there should be .020" to .060" clearance between the lock loop roller and the lock loop cam when the transmitting cam sleeve is rotated to make this clearance a minimum. To adjust, position the backstop screw.

ORIGINAL

KEYBOARD CAM OPERATED CONTACTS ADJUSTMENTS

359. PULSING CONTACT

a. Rotate the keyboard shaft until the clutch is completely disengaged (roller on lock loop passed high point of lock loop cam). There should be a gap of .010" to .020" between the contacts. To adjust bend the lower short contact spring.

b. With the clutch engaged and the keyboard shaft rotated until the insulator on the long contact spring is free of the lock loop arm, hook an 8 oz. scale under the long contact spring and pull upward. It should require 3 to 4 ozs. to separate the contacts. To adjust, bend the long contact spring. Recheck a.

MECHANISM FOR OPENING AND CLOSING EXTERNAL CIRCUITS

360. LEFT CONTACT ASSEMBLY

a. The insulator on the end of the long contact spring should be centered beneath the lobe on the end of the function lever. To adjust, loosen the two contact pile-up mounting screws and position the assembly. Tighten the mounting screws.

b. With the main shaft rotated so that the contact function lever is resting against the rear edge of the vanes, but not selected, there should be some clearance, not more than .010", between the insulator on the long contact spring, and the lobe on the function lever. To adjust, bend the long contact spring.

c. Under the above condition, there should be a gap of .015" to .020" between the contacts. To adjust, bend the short contact spring.

361. LEFT FUNCTION LEVER SPRING TENSION

With the function lever resting against the rear edge of the vanes, but not selected, and the contact spring held away, hook a 32 oz. scale under the extreme front end of the lever and pull vertically upward. It should require 24 to 32 ozs. to start the function lever moving.

362. RIGHT CONTACT ASSEMBLY

a. The upper contact spring should be parallel to the function lever spring plate. To adjust, position the contact assembly bracket with its mounting screws loosened.

b. With the printing bail in its extreme rear position the insulator on the center contact spring should just touch the end of the contact lever. To adjust, position the contact pile-up with its mounting screws loosened. Make certain the contacts meet squarely before tightening the pile-up mounting screws. If necessary, bend the contact springs.

c. With the adjusting screw on the right function lever turned so that the contact lever is out of engagement with the insulator on the center contact spring, hook an 8 oz scale under the center contact spring between the contact and the insulator and pull vertically upward. It should require 4-1/2 to 5-1/2 ozs. to move the contact away from the lower contact. To adjust, bend the center contact spring.

NOTE

It may be necessary to bend the upper contact spring so that it does not interfere with the center contact spring when checking this adjustment.

d. With the main shaft rotated so that the right function lever rests against the rear edge of the vanes, but is not selected, there should be a gap of .030" to .040" between the center and upper contacts. To adjust, bend the upper contact spring.

e. With the right function lever fully selected against the vanes, there should be a clearance of .010" to .020" between the end of the contact lever and the insulator on the center contact spring. To adjust, position the contact lever adjusting screw with its lock nut loosened.

363. CONTACT LEVER SPRING TENSION

Rest the typing unit on its right side. With the printing bail in the extreme rear position and the insulator on the contact spring held away from the contact lever, hook a 32 oz. scale to the contact lever at the spring hole and pull horizontally in line with the spring. It should require 12 to 16 ozs. to start the lever moving.

364. RIGHT FUNCTION LEVER SPRING TENSION

Rotate the main shaft until the printing bail is in the extreme rear position. Unhook the spring from the spring plate and hold the function lever against its pivoting shaft. With a 64 oz. scale hooked in the function lever spring

eye, it should require 40 to 50 ozs. to pull the spring to position length.

END-OF-LAST-FORM INDICATING MECHANISM MOUNTED ON TYPING UNIT OF SPROCKET FEED PRINTERS

365. PAPER OUT BAIL

The vertical arm of the paper-out bail should drop freely into the platen groove. To adjust, add or remove shims between the paper-out bail and the right platen bracket.

366. LINE FEED DETENT LEVER - See paragraph 108.

367. PAPER - OUT BAIL SPRING

With the vertical arm of the paper-out bail resting on the bottom of the platen groove and the switch operating bracket held away from the bail, it should require 1-3/4 to 2-1/4 ounces to start the paper-out bail moving when pulling in a vertical direction on the paper bail at the vertical link connection, with an 8 ounce scale. To adjust, place a screwdriver in the slot of the 126751 eccentric shoulder screw to prevent its turning, and loosen the lock nut until the 126752 shoulder bushing is friction tight. Rotate the 126752 shoulder bushing (with a 73403 tommy wrench) in the direction to increase or decrease the tension to meet the above requirement. Retighten the lock nut.

NOTE

The spring should be anchored in the center of the three holes in the bushing. Recheck LINE FEED DETENT LEVER, paragraph 366.

368. VERTICAL LINK ECCENTRIC

With the paper-out bail resting on the bottom of the platen groove, there should be a minimum of 1/64" motion of the vertical link before picking up the paper-out bail, when operating the right pressure roller lever. To adjust, position the 126759 eccentric to meet this requirement.

369. SWITCH MOUNTING PLATE

The paper-out bail should just operate the switch when the vertical arm of the paper-out bail rests on the outer paper surface. The switch should be unoperated under either of two conditions: (1) When the end of the last form clears the paper-out bail; (2) When the pressure

rollers are raised as for the insertion of new forms. To adjust, loosen the mounting screws and position the switch mounting plate.

NOTE

The paper-out bail camming surface should be on the flat of the switch operating bracket arm when the bail finger is in contact with the paper.

END-OF-LAST-FORM INDICATING MECHANISM MOUNTED ON COVER OF SPROCKET FEED PRINTERS

370. CONTACT SPRING GAP

There should be .010" to .020" clearance between the contacts. To adjust, bend the short contact spring.

371. CONTACT LEVER SPRING TENSION

Hook an 8 oz. scale under, and as close as possible to, the end of the contact lever and pull vertically at a right angle to the lever. It should require 2 to 3 ozs. to just move the lever out of the hole in the paper guide.

FORM ACCUMULATING SHELF FOR SPROCKET FEED PRINTER COVERS

372. SHIELD POSITION

With the forms to be accumulated resting against the shield, the forward ends of the forms should be approximately 3/4" from the forward end of the accumulating shelf. To adjust, position the shield keeping it parallel to the rear wall of the cover.

SPROCKET FEED TEARING EDGE AND PAPER GUIDE

373. PAPER STRIPPER (Applicable only to units equipped with paper strippers in place of paper carrier belts and pulleys).

a. There should be some clearance, not more than .020", between the top projection of the strippers and the bottom of the platen groove when the lower projection is held against the bottom of the platen groove. To adjust, bend the stripper to meet this requirement.

b. There should be some clearance between the strippers and the rubber side of the grooves in the platen when the strippers are held against their locating collars. Under these conditions,

there should also be some clearance between the strippers and the platen roll sprocket rings. Adjust by means of the stripper locating collars. Check each stripper for one complete revolution of the platen.

NOTE

Place the cover over the printer and shift the platen to the FIGURES position for the following four adjustments.

374. PAPER GUIDE PLATE

Position the paper guide plate on the cover after loosening its four mounting nuts so that there is a 1/16" to 3/32" clearance between the front edge of the guide and the pressure roller lever shaft. Tighten the four mounting nuts on the paper guide plate.

375. TEARING EDGE MOUNTING BRACKET

Loosen the four mounting plate screws. Adjust the tearing edge mounting brackets in their slots for a clearance of 1/16" to 3/32" between the tearing edge blade and the pressure roller levers when the blade is in a position nearest the levers. Tighten the four mounting plate screws.

376. TEARING EDGE BLADE

Loosen the two mounting screws in the ends of the tearing edge blade and position the blade so that there is a 3/32" clearance between the tops of the pressure rollers and the underside of the blade.

377. COVER GAP

There should be a 3/16" to 1/4" gap between the paper guide plate and the edge of the glass. To adjust for this gap, loosen the two screws in each glass guide rail and move the glass and rails until the required gap is secured.

378. MARGIN GUIDE ADJUSTMENT

The margin guide, located at the left end of the paper guide plate, should be positioned from left to right, so that the paper forms will be located centrally on the platen. To adjust, loosen the margin guide mounting screws and position the guide; tighten the mounting screws. Recheck PAPER FINGER, paragraph 123.

PAPER-OUT MECHANISM

379. SWITCH PLUNGER OVERTRAVEL

Adjust the operating screw, which cams the switch operating bracket, so that it just activates the switch. Then loosen the screw an additional one-half turn to compensate for the overtravel of the switch plunger.

380. PAPER FOLLOWER ARM

NOTE

The adjustment as outlined herein is set for operation of the switch when the paper supply is reduced to approximately 10 to 15 feet on the roll.

With the follower arm spring unhooked, move the paper follower arm toward the empty paper spindle. The operating screw should operate the switch when the follower arm is approximately 1/4" above the paper spindle. To adjust, position the follower arm and its collar with the adjusting screw loosened. Tighten the screw and rehook the spring. Make certain that the switch is operated when the follower arm reaches a distance of 1/8" from the paper spindle.

381. PAPER FOLLOWER ARM SPRING TENSION

With the paper roll removed from the spindle, hook an 8 oz. scale under the paper follower arm where the arm comes in contact with the paper and pull vertically upward. It should require 1 to 3 ozs. to pull the arm to its horizontal position.

NOTE

The following adjustments apply to units equipped with fraction type characters.

382. RIBBON OSCILLATOR LEVER (Figure 119)

With the type bar carriage installed, shift the platen to the "Figures" position and rotate the main shaft until the ribbon carrier is in its uppermost position. Locate the ribbon oscillator lever by means of clamping screw and nut (carriage in extreme right position and the ribbon lockout bar in its unoperated position) so that the ribbon fully covers any fraction type character.

383. RIBBON OSCILLATOR ADJUSTABLE STOP (Figure 121)

a. Remove the type bar carriage from the unit and position the oscillator lever adjustable stop so that there is some overtravel of the oscillator extension over the stop plate (extension should not bind against stop plate) when the pull bar bail plunger is positioned so that there is from .010" to .050" clearance between the pull bars and the code bars.

b. Make the preceding check with the type bar carriage installed in the unit and with the platen in the "Figures" position and the printing bail in its rearmost position. With the main shaft in its stop position, the top edge of the ribbon should not be above the bottom edge of the printed character.

NOTE

The following two adjustments apply to Model 15 Typing Unit using the 142545 Contact assembly.

384. SPRING CONTACTS

With the send-receive-break operating lever in the send position (up) and the horizontal tabulator in unselected position, the contact lever adjusting screw in contact with the tabulator bail, there should be from .015" to .025" clearance between the normally open contact and the swinger contact, while the other swinger contact is against the normally closed contact.

To adjust, bend spring contacts and stiffener to meet requirement.

385. CONTACT LEVER ADJUSTING SCREW

With the send-receive-break lever in send position (up), the horizontal tabulator in actuated position, and the swinger contact against the normally open contact, there should be not less than .015" clearance between the swinger contact and the normally closed contact.

To adjust, loosen lock nut on tabulator contact lever adjusting screw. Position contact lever by means of the adjusting screw to meet the requirement. Recheck the Spring Contacts Adjustment.

UPPER CASE "H" OR "BLANK" CONTACTS

386. TYPING UNIT SLIP CONNECTION SPRING
- Same as paragraph 199.

387. UPPER CASE "H" CONTACT ASSEMBLY

a. Light Contact Spring. With the printing bail in its extreme rear position, bend the light contact spring so that it requires 4 to 6 ozs. to just break contact with the heavy spring. In measuring this spring tension hook an 8 oz. scale at the point of contact and pull horizontally at right angle to the spring.

b. Heavy Contact Spring. With the platen in the figures position, set up the "H" combination (3 and 5 marking) and rotate the main shaft until the upper case "H" function lever is completely selected. Then bend the heavy contact spring to provide from .010" to .015" gap between the contacts.

c. Recheck the Light Contact Spring Adjustment.

388. UPPER CASE "H" FUNCTION LEVER SPRING TENSION

With the function lever resting against the rear edges of the vane but not in selection, hook a 12 lb. scale under the extreme front edge of the lever at the bend and pull at right angle to the front extension of the lever. It should require from 13 to 17 ozs. (for the 74962 spring) or 5 to 6 lbs. (for the 82788 spring) to start the lever moving.

NOTE

On typing units equipped with the old style 74255 function lever comb, it will be necessary to check adjustments (4) and (5).

389. SIGNAL BELL LATCH BAR LATCH - Same as paragraph 134.

390. CARRIAGE RETURN LATCH BAR LATCH
- Same as paragraph 140.

391. BLANK CONTACT BRACKET

With some combination (other than "blank") selected and with the "blank" function lever forward against the selector vanes position the contact bracket so that the contact extension just touches the bottom of the "blank" function lever extension.

392. BLANK CONTACT ASSEMBLY

a. Lower Contact Spring. With the "blank" function selected and with the printing bail in its extreme forward position, the contacts should be closed and it should require a horizontal of 4-1/2 to 5-1/2 ozs. to just separate the contacts. When measuring this tension, hook an 8 oz. scale on the end of the lower contact spring and pull at a right angle to the spring. This adjustment is obtained by bending the lower contact spring.

b. Lower Spring Stiffener. With the printing bail in its extreme rear position and with the function lever extension clear of the upper contact extension, there should be a contact gap of .010" to .015". Bend the lower spring stiffener to obtain this gap.

c. Recheck Lower Contact Spring Adjustment.

d. Make certain that there is clearance, between the contact assembly and the plate and also between the send-receive-break parts and the contact mechanism.

SECTION 2

LUBRICATION

1. GENERAL

a. Proper attention to lubrication is of the utmost importance.

b. Use Teletype KS7470 oil at all locations where the use of oil is indicated. Use KS7471 grease on all surfaces where grease is indicated, except the motor bearings. Apply two drops of KS7470 oil to motor bearings every four months (depress oiler with metal object). If the motor is disassembled at any time, repack the bearings with KS7471 grease.

c. All spring wicks and felt oilers should be saturated. The friction surfaces of all moving parts should be thoroughly lubricated. Over-lubrication, however, which will permit oil or grease to drip or be thrown on other parts, should be avoided. Special care must be taken to prevent any oil or grease from getting between the armature and its magnet pole face or between electrical contacts.

d. Apply a thick film of grease to all gears.

e. Apply oil to all cams, including the camming surfaces of each clutch disk.

f. The following lubricants have been standardized for use on all types of Teletype apparatus. These lubricants supersede those referred to in preceding Teletype specifications. The lubricants can be ordered from Teletype as follows:

88970	1 Qt. of KS7470 Oil
88971	1 Gal. of KS7470 Oil
88973	1 LB. of KS7471 Grease
88975	KS8319 Grease Gun
97116	4-oz. Tube of KS7471 Grease

The above grease is recommended instead of oil for lubricating motors equipped with ball bearings. The 88975 grease gun should be used for injecting grease into the bearings of Teletype ball bearing motors. The gun may be used also for applying grease to other parts of the apparatus and no other grease container need be carried. If this grease gun is not available, the oil listed in the foregoing should be substituted for

lubricating ball bearing motors.

g. Instructions for Filling the Grease Gun

(1) Unscrew the lubricant tube from the cap casting of the grease gun.

(2) Insert fresh lubricant through the open end of the tube with the fingers. Apply gradually to eliminate air pockets.

(3) Tamp the lubricant down solidly in the tube by pounding the closed end solidly against the palm of the hand. Continue to add lubricant until the tube is completely filled and the metal follower rests against the perforated tube cover.

(4) Fill the cap casting with lubricant flush to the bottom side of the tube threads.

(5) Screw the lubricant tube into the cap casting part way only. Then insert a pencil or rod through the perforated tube cover and exert pressure against the metal follower so as to expel any entrapped air past the tube threads. When lubricant begins to ooze through the threads, tighten the lubricant tube securely in the cap casting.

(6) Operate the handle back and forth for several strokes or until lubricant is pumped from the nozzle. The gun is then ready for use. If the lubricant does not flow from the nozzle in a solid stream, it is an indication that all air has not been expelled from the lubricant tube. Invert the gun and pound the cap casting end against the palm of the hand to jar the lubricant into the pump cylinder.

h. Instructions for Lubricating Motor Ball Bearings.

The motor bearings are packed with grease before the motor leaves the factory and under ordinary operating conditions need no additional lubrication for approximately two months. At the regular lubricating intervals one or two strokes of the plunger of the gun should apply sufficient grease to each bearing. To lubricate, press the nozzle of the gun against the ball oiler and force the grease into the hole by pushing on

the plunger of the gun. Care should be taken that the bearings are not overloaded. Overloading will result in the grease oozing out of the end castings and being forced into the motor or being thrown on other parts of the mechanism. After lubricating, the motor should be run for a few minutes and then any excess grease that has been forced out of the ends of the castings should be wiped off. Each time that the gun is used for lubricating a motor bearing, the plunger should first be depressed slightly to make sure that grease will be delivered.

i. Oil both loops of all helical springs that exert a nominal tension of less than 2-1/2 pounds.

j. Apply grease to both loops of all helical springs that exert a nominal tension of 2-1/2 pounds or more.

2. TYPING UNIT

a. TYPE BAR CARRIAGE ASSEMBLY

- (1) Type bars - at segment slot.
- (2) Code bars - at posts.
- (3) Code bar bell cranks - on wearing surfaces.
- (4) Pull bar bail guide rollers and guide surface (oil-grease-oil).
- (5) Plunger surface and rollers, surface of pull bar bail guide post (oil-grease-oil).
- (6) Operating roller (oil-grease-oil).
- (7) Carriage support rollers - three.
- (8) Ribbon reverse bail.
- (9) Ribbon feed shaft bearing - 3 oil holes.
- (10) Ribbon feed pawl.
- (11) Ribbon feed pawl operating lever pivot screw and wearing surface.
- (12) Ribbon feed ratchet - teeth.
- (13) Ribbon lockout bar - at type bar segment slot.
- (14) Ribbon feed shaft bearings - upper and lower.

(15) Ribbon feed mechanism gears.

(16) Ribbon spool shafts bushings - remove spools.

(17) Ribbon reverse shafts - upper and lower bearings, arms, pawls, and levers.

(18) Margin bell pawl.

(19) Ribbon shift lever and roller.

(20) Oscillator lever shoulder screw and carriage casting slot.

(21) Spacing rack.

(22) Ribbon reverse detent.

(23) Ribbon feed shaft detent - grease.

(24) (Two-Color Ribbon) Ribbon oscillator lever latch - at bearing and latching surface.

3. TYPING UNIT LESS THE TYPE BAR CARRIAGE ASSEMBLY

a. PLATEN UNIT

- (1) Shaft bearings (one in each shaft hub).
- (2) Line feed detent lever mounting shoulder screw.
- (3) Line feed detent roller.
- (4) Single-double line feed lever between flat spring and detenting cam and where single-double line feed lever fits into groove in platen shaft hub.
- (5) Line feed pawl and operating lever shoulder screws.
- (6) Shift detent roller - (grease).
- (7) Platen unit pivot bearings.
- (8) Upper ends of line feed and shift vertical links.
- (9) Paper knife supporting arms and paper guide bearings.
- (10) Paper straightener lever bearings.

(11) Paper straightener rod supporting lever bearings.

(12) Pressure roller release shaft and crank bearings.

(13) Pressure roller release cams, crank and shoulder screws.

(14) Pressure roller shafts - bearing surface.

(15) Pressure roller sleeves (one dropeach).

(16) Letters and figures stop screws - grease ends.

(17) Platen friction disc assembly - saturate felt washer with oil (separate discs).

(18) Paper spindle bearings.

(19) Line feed check lever shaft bearings.

(20) Line feed detent ratchet - (apply grease sparingly).

(21) Left end of platen shaft before installing platen crank.

b. MAIN SHAFT

(1) Hold right end of printer up about 6" and remove oil plug. -Fill shaft until oil runs out of the left end.

(2) Main clutch sliding member (oil freely).

(3) Main clutch throwout lever pivots - (oil-grease-oil).

(4) Main shaft friction washers - saturate with oil (separate discs).

(a) Selector unit assembly - 2 friction washers.

(b) Spacing clutch friction washer.

(5) Locking lever cam felt washers on selector cam assembly.

(6) Selector cam sleeve - each cam peak.

(7) Main shaft right ball bearing - (oil-grease-oil).

(8) Main shaft left ball bearing.

(9) Thrust bearing - end balls.

(10) Spacing clutch spring coils - (permitting oil to flow between prongs of driven member of spacing clutch and worm gear sleeve.)

(11) Spring (coils) which compresses friction washers of selector cam assembly - (oil will flow between prongs of nut on main shaft and friction disc which engages with this nut).

(12) Cam unit and spacing clutch, oil holes.

(13) Main clutch camming surface.

(14) Main shaft cam surfaces - (grease).

(15) Spacing escapement ratchet teeth - (grease).

c. SELECTOR UNIT.

NOTE

Be careful not to get oil between the pole faces of the selector magnets and the magnet armature.

(1) Armature bearings - two.

(2) Trip latch plunger, trip latch and bell crank lever and stop lever of range finder assembly.

(3) Swords and selector levers - drop oil between separating plates of swords and levers.

(4) "T" levers - (all points of contact).

(5) Armature locking lever.

(6) Locking wedge - at point of engagement with locking lever.

For printers equipped with armature detent items (7) and (8) apply.

(7) Armature detent - bearing.

(8) Armature detent pin - where it comes in contact with detent - grease.

NOTE

Selector cam sleeve is listed under Main shaft.

d. BAIL UNIT ASSEMBLY.

(1) Bail assembly shaft bearings - fill oil cup - (two oil cups - new style).

(2) Between spacing pawls.

(3) Function bail and printing bail operating arm bearings.

(4) Function lever bail roller - two bearings (oil-grease-oil).

(5) Roller surface to have film of grease.

(6) Function bail and printing bail operating arm and rollers (oil-grease-oil).

(7) Printing bail blades where plunger operating roller engages blades.

(8) Printing bail adjusting screw head - (grease).

e. VANE FRAME ASSEMBLY.

(1) Function levers in vane frame slot.

(2) Function levers in slots in break mechanism plate.

(3) Function levers push bars and latch bars - in function lever comb.

(4) On Model 15 Typing Units, sixth vane extension - at point of engagement with LETTERS push bar.

(5) Vane pilot screws - bearings.

(6) Send-receive-break mechanism, intermediate lever mounting screw, and operating lever mounting screw - (Be careful not to get oil on friction spring washer of send-receive-break mechanism "T" lever).

(7) Vanes front edges - where bell crank slotted ends slide in engagement with vanes.

(8) Sixth vane detent roller.

(9) Locking function lever - (apply grease in notches).

f. SPACING SHAFT ASSEMBLY.

(1) Spacing shaft - upper bearing, oil; lower bearing, fill oil cup.

(2) Carriage return clutch members prongs.

(3) Spacing gear, lower - (grease).

(4) Spacing gear, upper.

g. CARRIAGE RETURN MECHANISM.

(1) Carriage return latch bar at point of engagement with latch - (grease).

(2) Carriage return clutch release fork and operating lever bearings.

(3) Carriage return push bar and latch bar operating lever shoulder screw.

(4) Carriage return locking bar bell crank link shoulder screw.

(5) Carriage return spring drum bearing.

(6) Carriage return spring release lever shoulder screw.

(7) Clutch release fork link shoulder screw.

(8) Locking bar bell crank upper cross bar casting shoulder screw.

(9) Locking bar and locking bar bell crank shoulder screw.

(10) Locking bar latch and left-hand side frame shoulder screw.

(11) Dashpot piston rod - one drop oil rubbed over surface of piston.

(12) Dashpot lever mounting shoulder screw, and roller mounting pilot screw. (Grease at point of contact with lefthand margin adjusting screw.)

(13) Type bar carriage assembly - upper and lower, track surface.

(14) Carriage return spring - through oil holes in drum.

(15) Spacing stop lever and shoulder screw.

(16) Carriage return operating lever stop screw - (grease).

h. BELL FUNCTION.

(1) Bell striker arm and arm operating lever - bearings.

(2) Bell push bar and latch bar shoulder screw.

(3) Bell latch bar at point of engagement with latch - (grease).

i. SHIFT-UNSHIFT MECHANISM.

(1) The figures and letters push bars shoulder screw.

(2) Bell crank lever and operating lever shoulder screw.

(3) Bell crank lever and operating lever joint.

(4) Shift vertical link, lower end and detent lever shoulder screw.

j. LINE FEED FUNCTION.

(1) Line feed push bar and bell crank lever shoulder screw.

(2) Bell crank lever mounting shaft.

(3) Vertical link and bell crank lever, lower end, shoulder screw.

(4) Margin bell shaft - 2 bearings.

4. MOTOR UNIT

a. Motor pinion - (grease).

b. Motor bearing oilers - two.

c. Motor speed lever - pilot screw.

5. BASE

a. SEND-RECEIVE-BREAK MECHANISM.

(1) Operating lever and safety pawl release lever shoulder screw.

(2) Contact operating lever - shoulder screw - (also drop oil between lever and rear surface of send-receive-break mechanism bracket).

(3) Reset lever shoulder screw - (also drop oil between reset lever and rear surface of bracket).

6. KEYBOARD

a. LUBRICATION ON BOTTOM SIDE OF KEYBOARD.

(1) Universal bar pilot screw - bearings.

(2) Trip-off pawl link - joint.

(3) Key levers on key lever shaft and in rear comb.

(4) Selector bars - in guide slots.

(5) Locking levers - at locking lever forks.

(6) On Model 20 units, shift rockers - bearings and links.

b. LUBRICATION ON TOP SIDE OF KEYBOARD.

(1) Key levers - in front comb.

(2) Space bar loop - on space bar loop shaft.

(3) Keyboard shaft - two oil cups.

(4) Keyboard clutch - sliding member.

(5) Cams - apply light film of grease to surfaces of all cams.

(6) Locking loop - pilot screw, bearings and roller.

(7) Contact lever pivoting shaft and guiding comb.

(8) Locking levers in locking lever comb.

(9) Clutch throwout lever - bearings.

(10) Trip-off and clutch lever pawls.

(11) Keyboard gear - (grease).

(12) On Model 15 units, repeat space rod at bearing points and points of contact.

7. VARIABLE FEATURES

a. SPROCKET FEED.

Same as for friction feed except omit from 3. a. PLATEN UNIT items (9) through (15) inclusive, and add the following:

(1) Pressure roller shaft - bearing surfaces.

(2) Pressure rollers - bearings.

(3) Paper carrier belt rollers.

b. PLATEN INDEXING MECHANISM.

(1) All gears - oil-grease-oil.

(2) Idler gear stud.

(3) Clutch washer.

(4) Cam assembly stud.

(5) Cam assembly bushing.

(6) Contact lever pivot.

(7) Cam - grease.

- (8) All springs.

c. MECHANICAL MOTOR STOP MECHANISM.

(1) Motor stop pawls shoulder screws and lever bearings.

(2) Release lever bearing, contact lever bearing, and where contact lever protrudes through break mechanism plate.

d. ELECTRICAL MOTOR STOP MECHANISM.

(1) Start magnet armature and locking lever.

(2) Stop magnet armature.

e. HORIZONTAL TABULATOR MECHANISM.

(1) Tabulator pawl shoulder screw.

(2) Tabulator stops - (grease).

(3) Tabulator bar bearing screws.

(4) Space pawl link - at slot.

(5) Tabulator latch - latching surface.

(6) Tabulator latch bar - at pivot and at link shoulder screw.

(7) Tabulator function lever - at pivot point and at point of engagement with lock bar.

f. SWITCH CUT-IN AND AUTOMATIC CUT-OUT OF HORIZONTAL TABULATOR.

(1) Spacing stop lever and shoulder screw.

(2) Blocking lever bearings and shoulder screw.

(3) Blocking surface of blocking lever extension - oil-grease.

g. REPERFORATOR MOTOR CONTROL MECHANISM.

(1) Contact pawl shoulder screw.

(2) Latch shoulder screw.

h. TWO-COLOR RIBBON MECHANISM

(1) Armature at its bearing - 2 places.

(2) Parallelogram bar link - 2 places.

(3) Parallelogram bar, when it connects to armature, and contacts latch on carriage.

(4) Upper rail link.

(5) Contact operating lever.

(6) Contact operating lever latch.

i. END - OF - LAST FORM INDICATING MECHANISM.

(1) Pivots of paper - out bail.

(2) Switch operating bracket arm.

(3) All shoulder screws.

(4) Reset lever camming surface - grease sparingly.

j. PAPER-OUT MECHANISM.

(1) Paper follower arm hub.

k. WORD AND OPERATIONS COUNTER

(1) Bearing points and pivots.



UPPER CASE	WEATHER SYMBOLS	↑ ⊕ ○ / 3 ! 8 / - / . ⊕ 9 0 1 4 ' 5 7 ⊕ 2 / 6 + -	COMMUNICATIONS	- ? : \$ 3 ! 8 / - / . ⊕ 9 0 1 4 ' 5 7 : 2 / 6 " -	LOWER CASE	A	B	C	D	E	F	G	H	I	J	K	L	M	N	O	P	Q	R	S	T	U	V	W	X	Y	Z	BLANK	G.R.	L.F.	SPACE	LTR. SHIFT	FIG. SHIFT	
						•	•	•	•	•	•	•	•	•	•	•	•	•	•	•	•	•	•	•	•	•	•	•	•	•	•	•	•	•	•	•	•	
						•	•	•	•	•	•	•	•	•	•	•	•	•	•	•	•	•	•	•	•	•	•	•	•	•	•	•	•	•	•	•	•	
						○	○	○	○	○	○	○	○	○	○	○	○	○	○	○	○	○	○	○	○	○	○	○	○	○	○	○	○	○	○	○	○	○
						•	•	•	•	•	•	•	•	•	•	•	•	•	•	•	•	•	•	•	•	•	•	•	•	•	•	•	•	•	•	•	•	
						•	•	•	•	•	•	•	•	•	•	•	•	•	•	•	•	•	•	•	•	•	•	•	•	•	•	•	•	•	•	•	•	

FIGURE 1

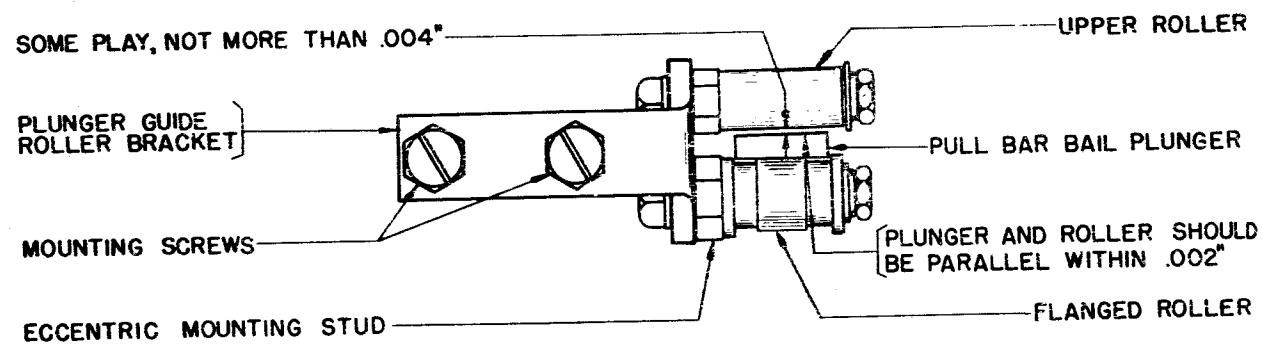

FIGURE 2

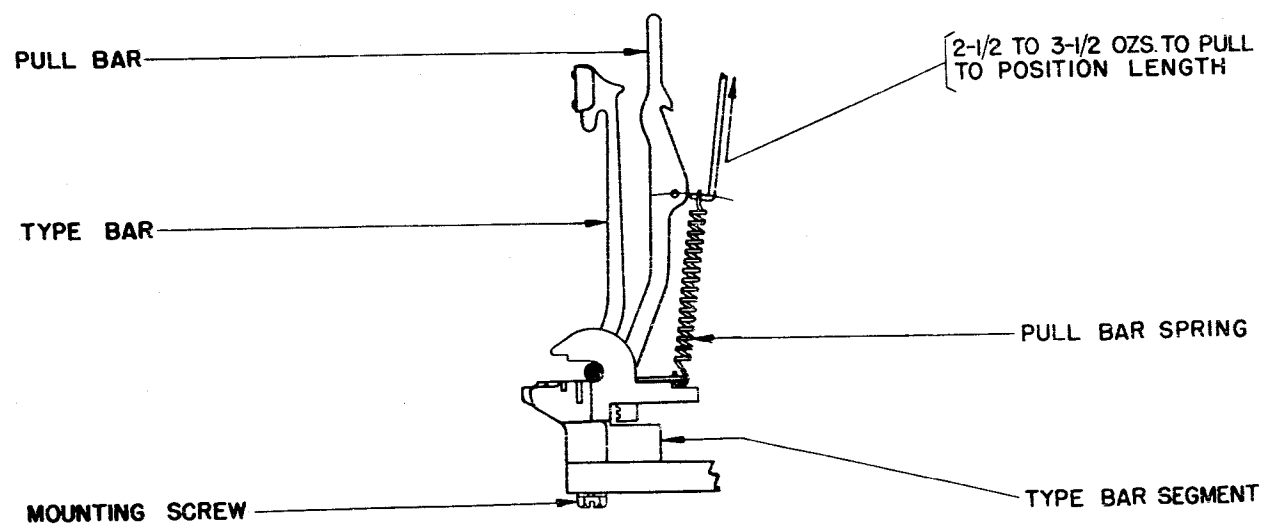

FIGURE 3

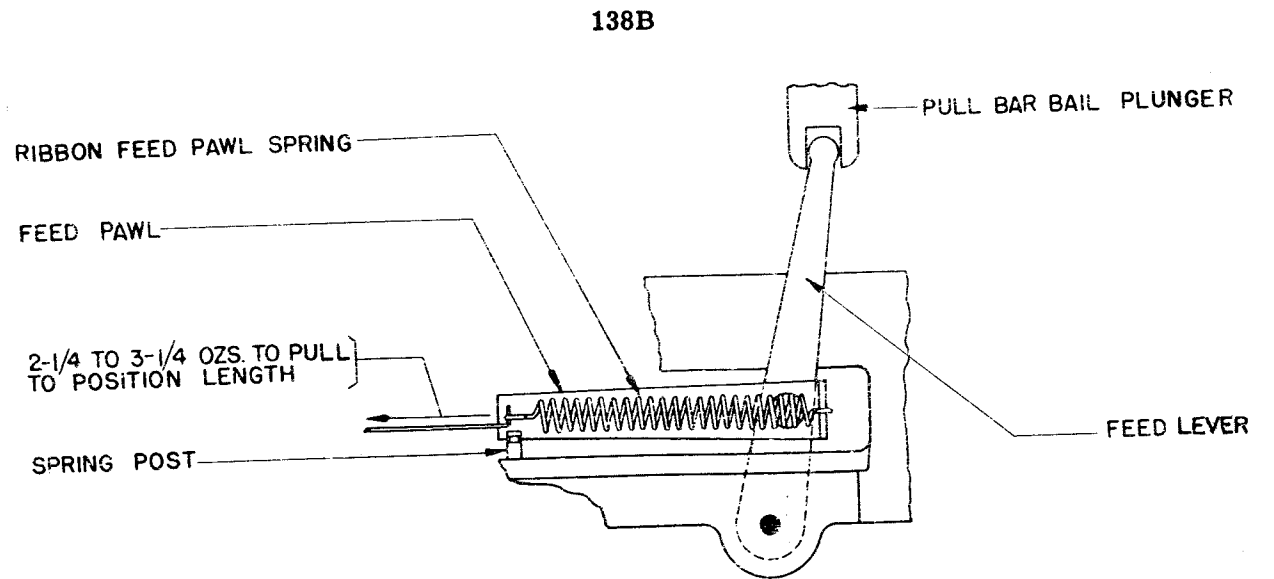

FIGURE 4

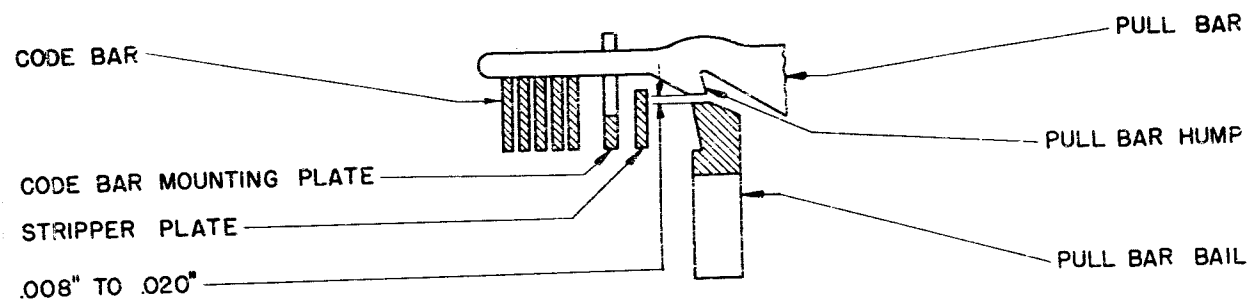

FIGURE 5

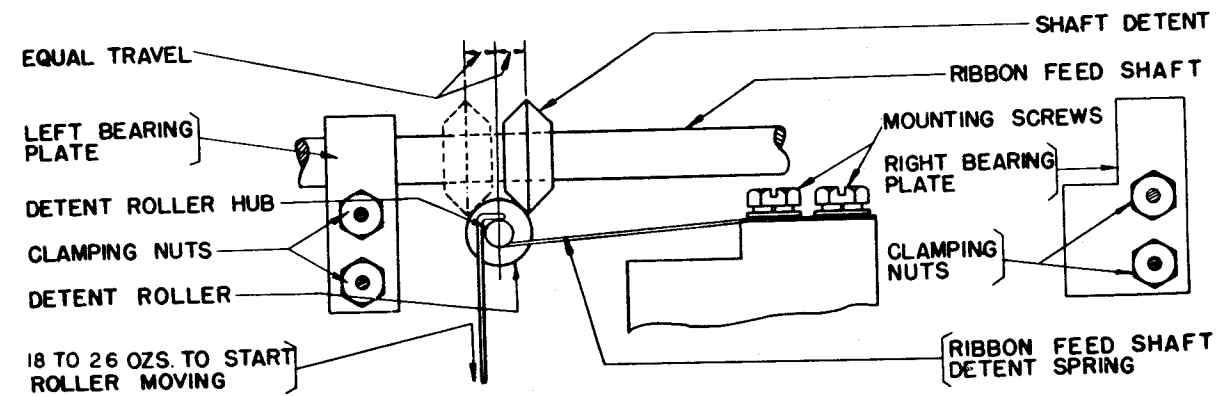

FIGURE 6

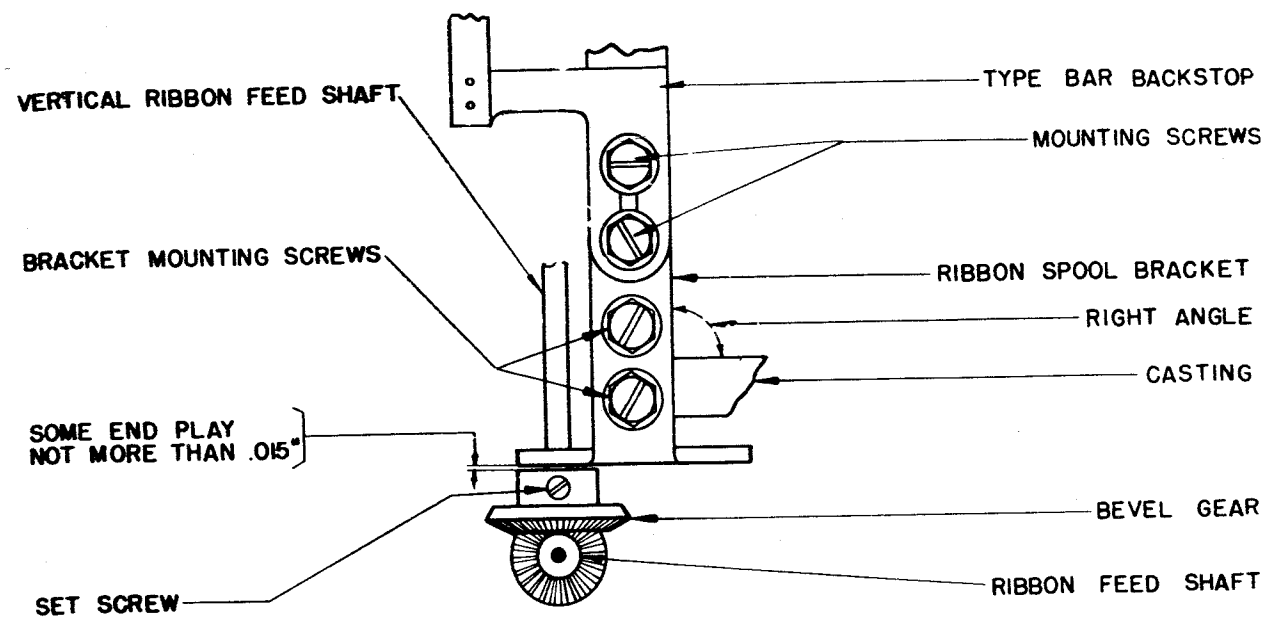

FIGURE 7

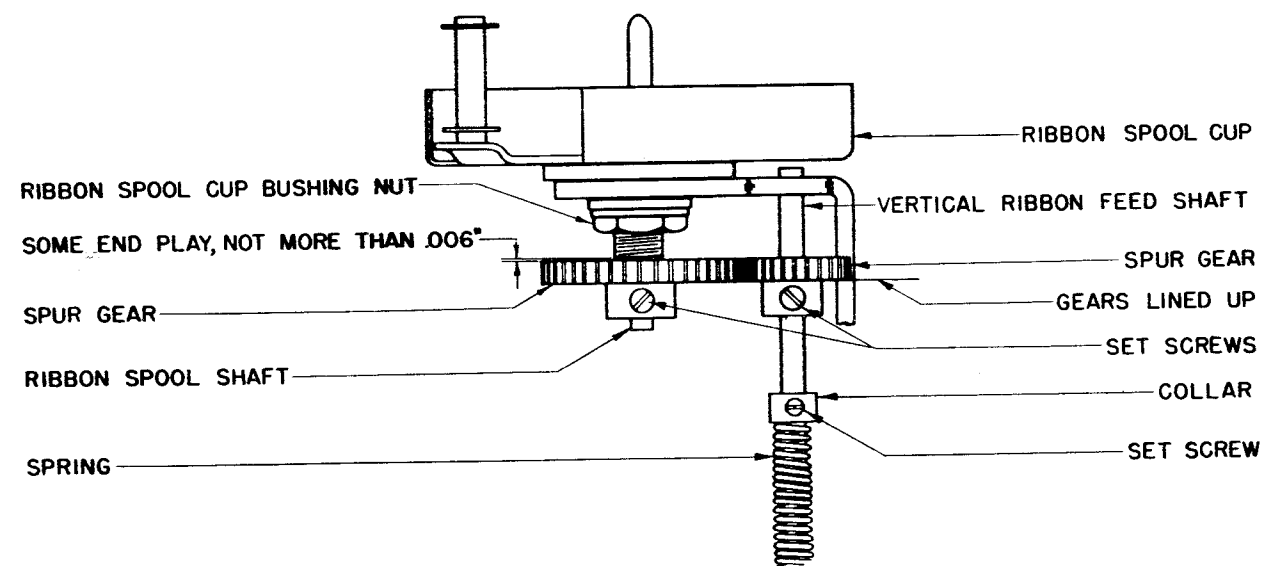

FIGURE 8

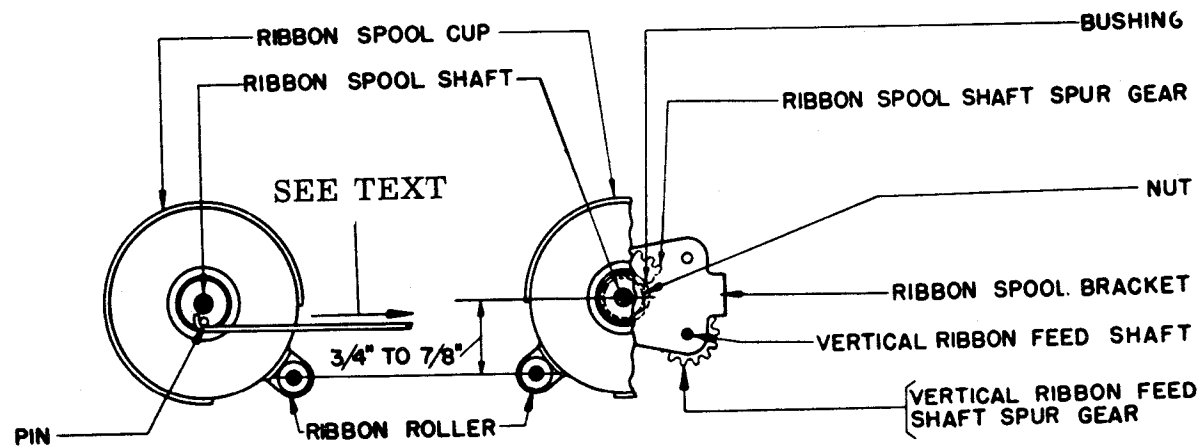
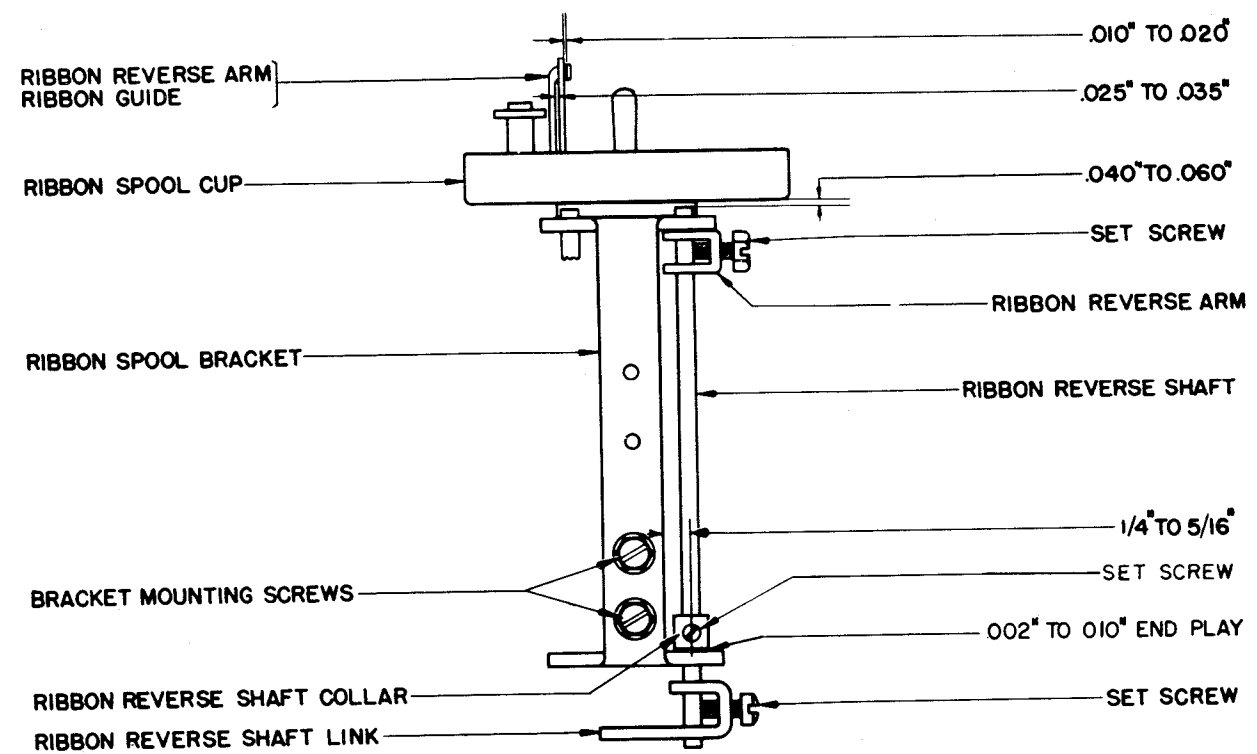

FIGURE 9

CHANGE 3

138B



(A)

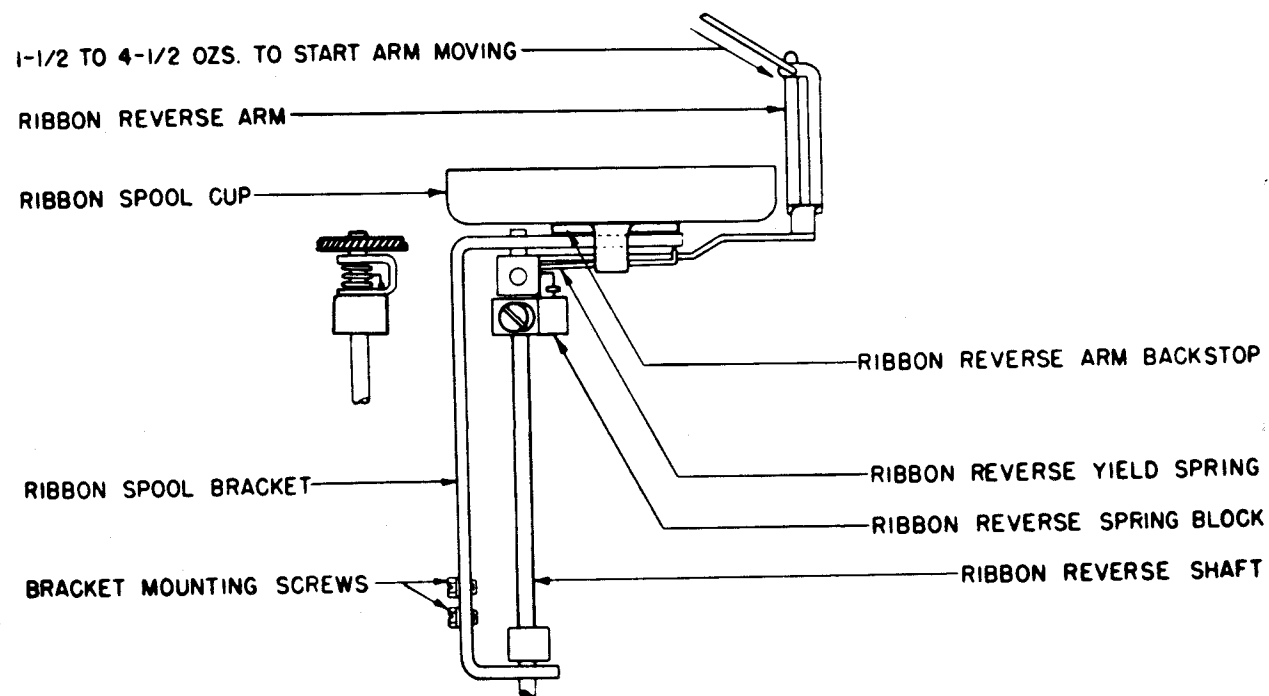

(B)

FIGURE 10

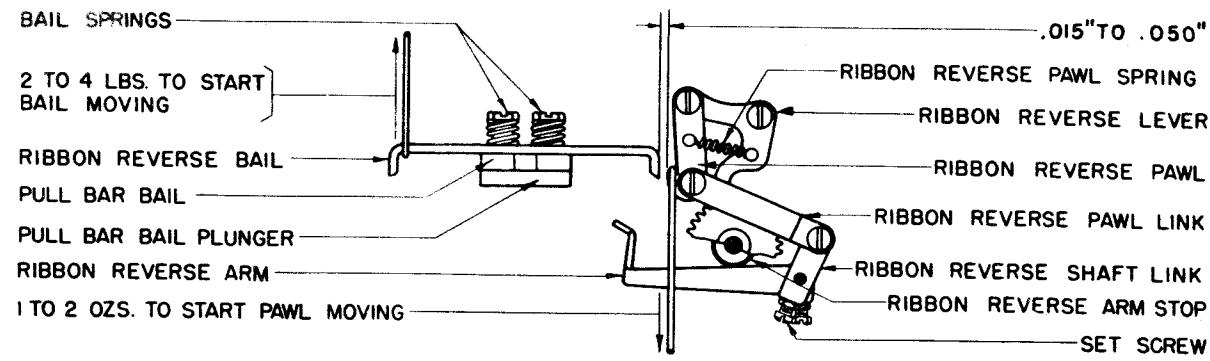

FIGURE 11

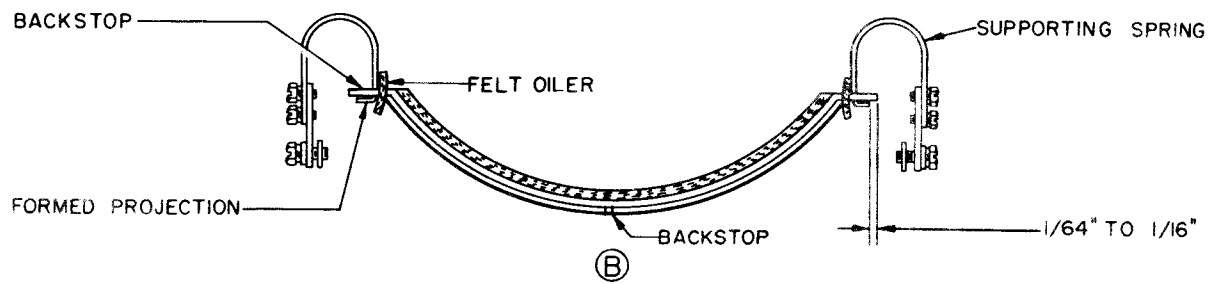
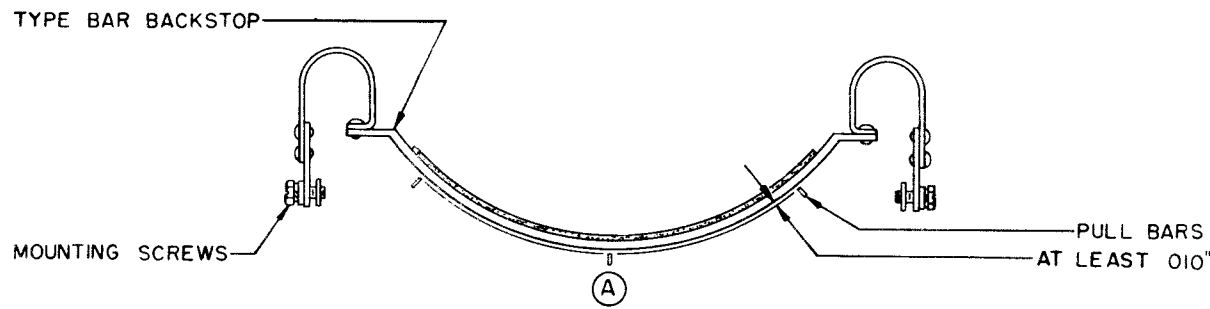

FIGURE 12

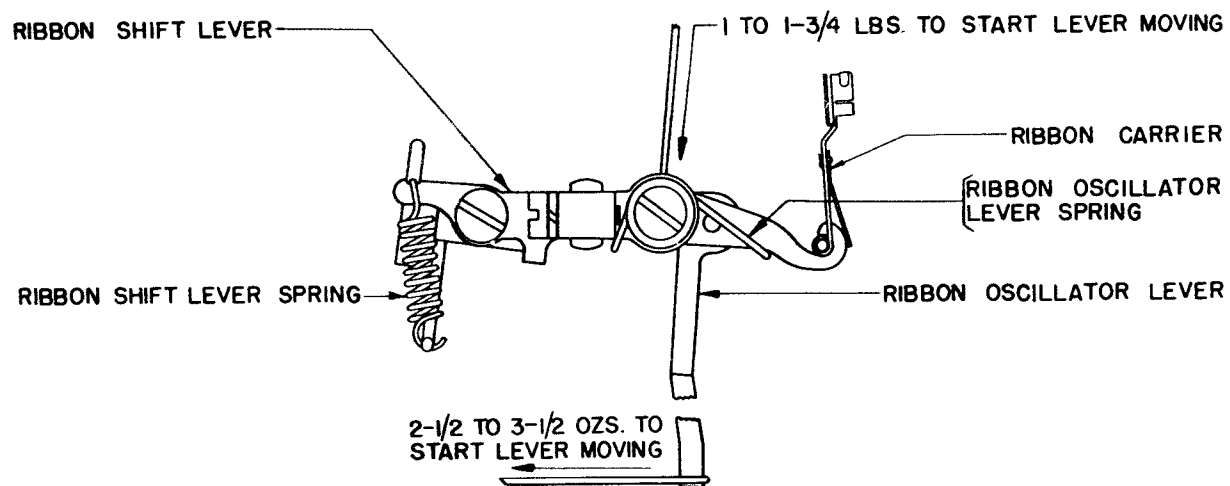

FIGURE 13

ORIGINAL

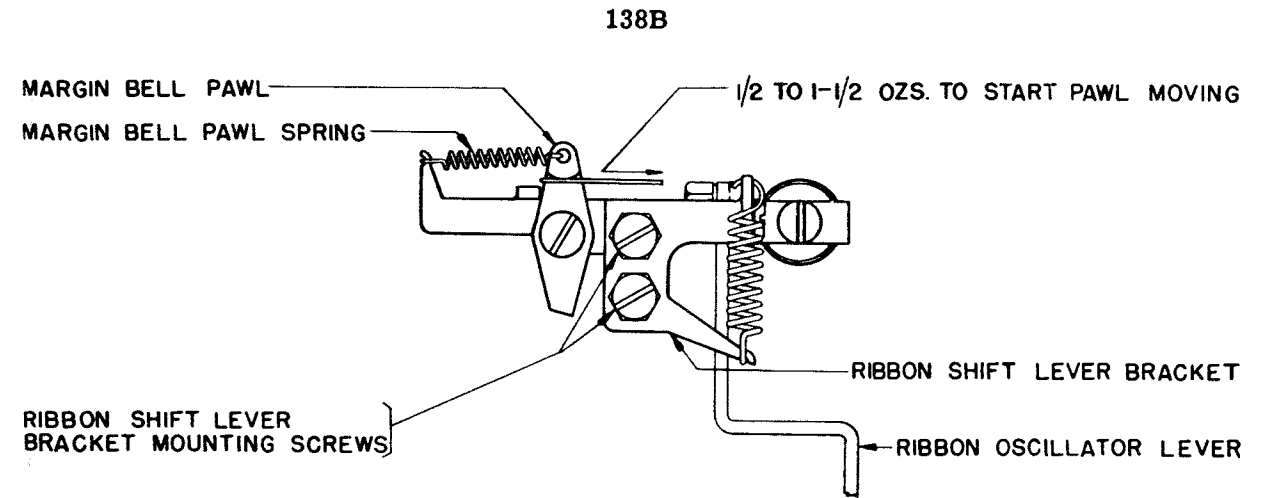

FIGURE 14

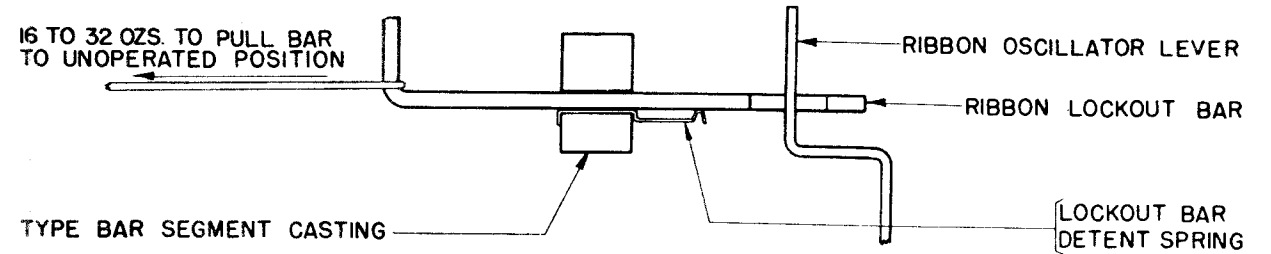

FIGURE 15

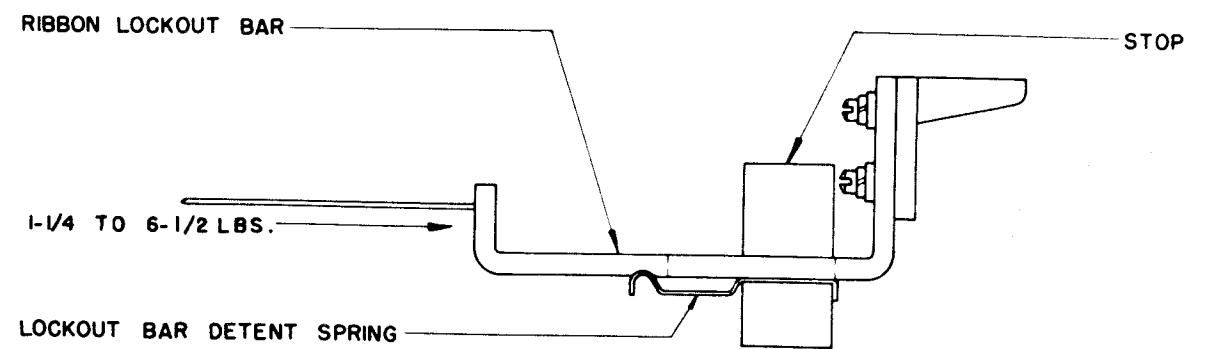

FIGURE 16

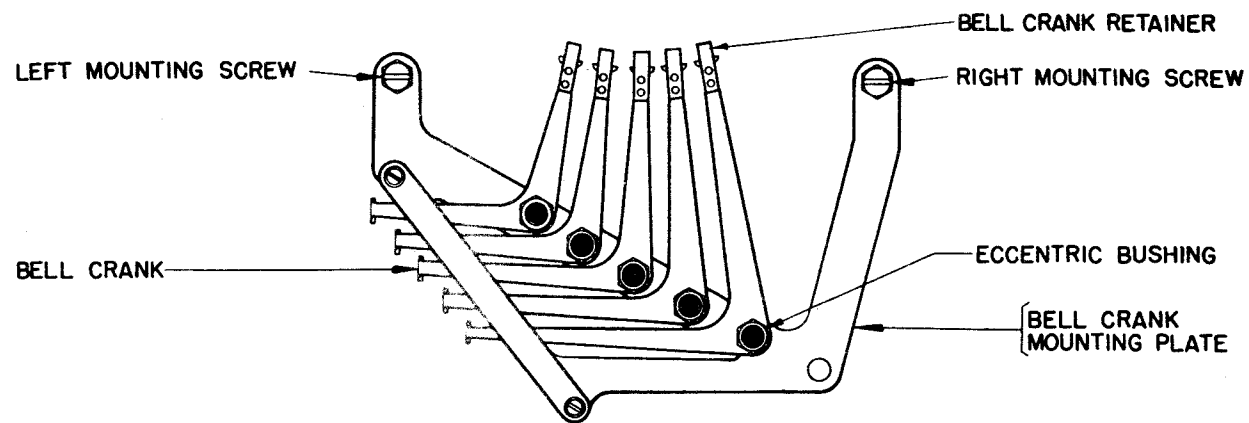

FIGURE 17

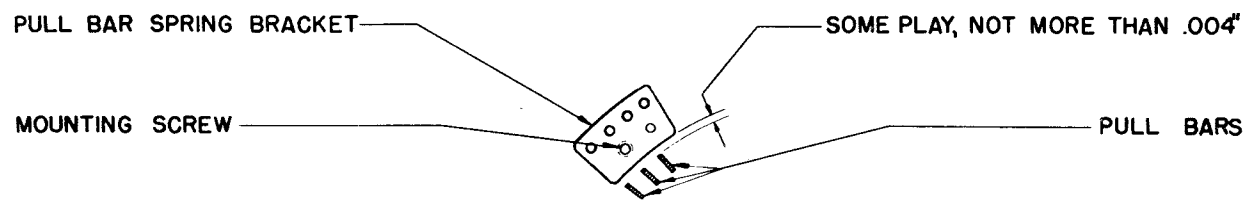

FIGURE 18

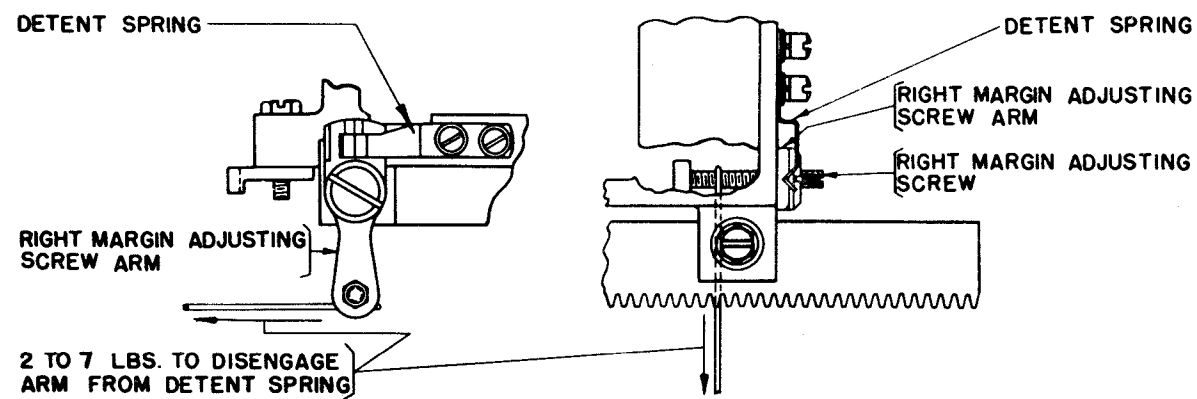

FIGURE 19

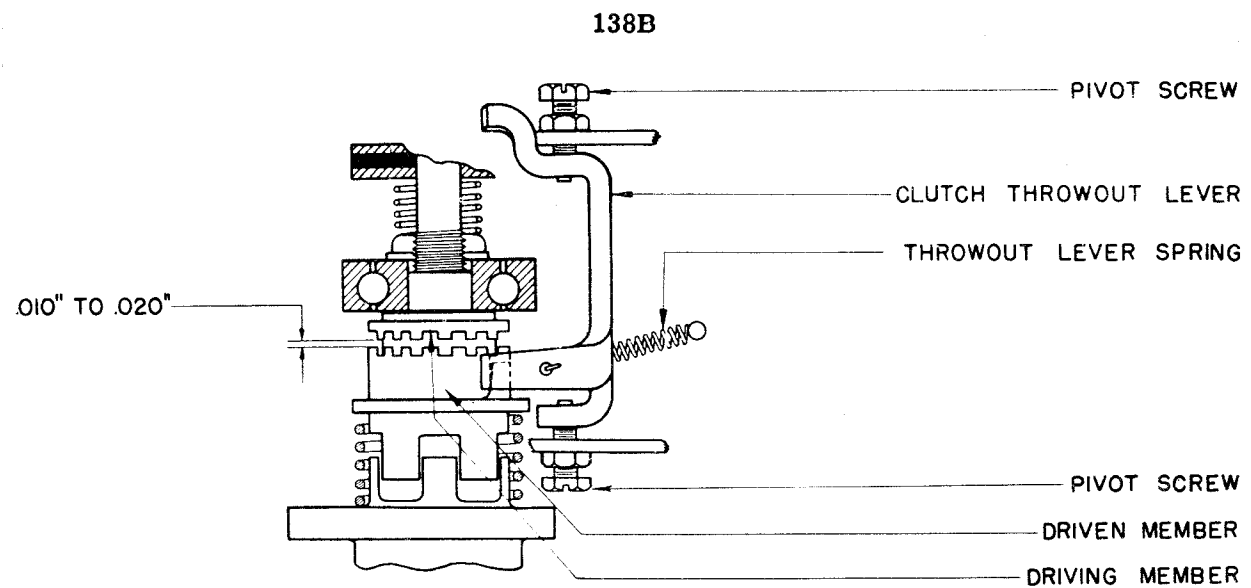

FIGURE 20

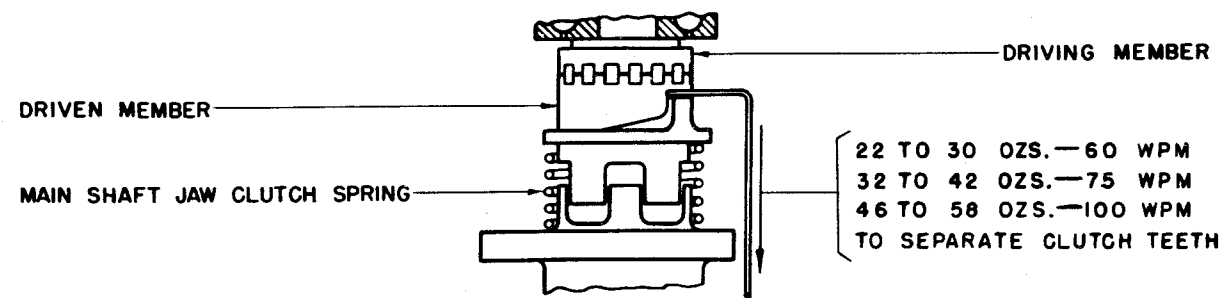

FIGURE 21

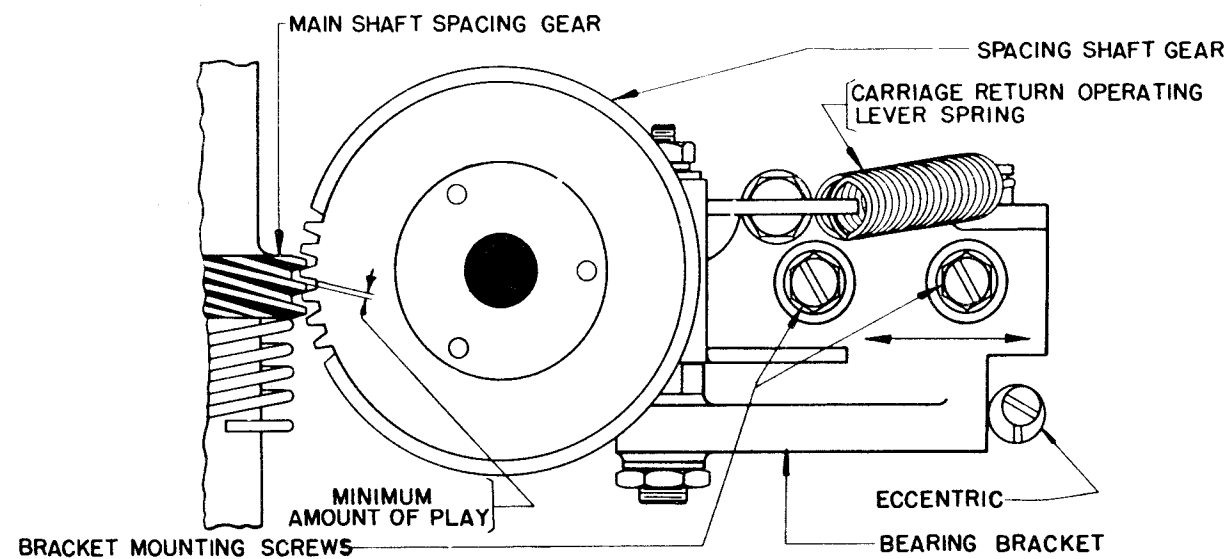

FIGURE 22

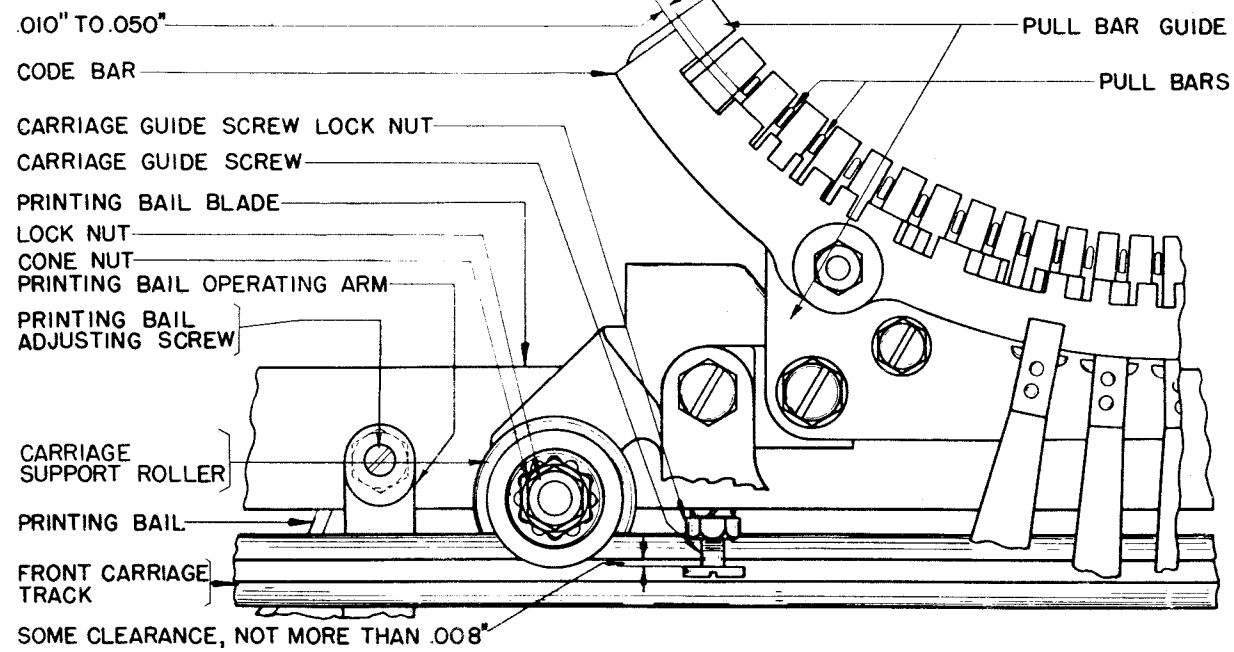

FIGURE 23

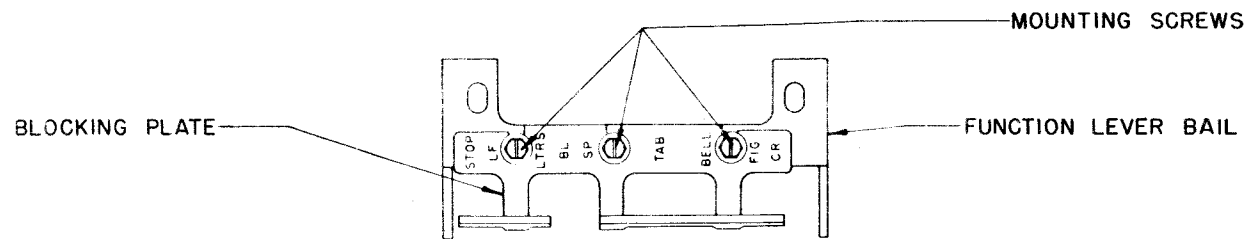

FIGURE 24

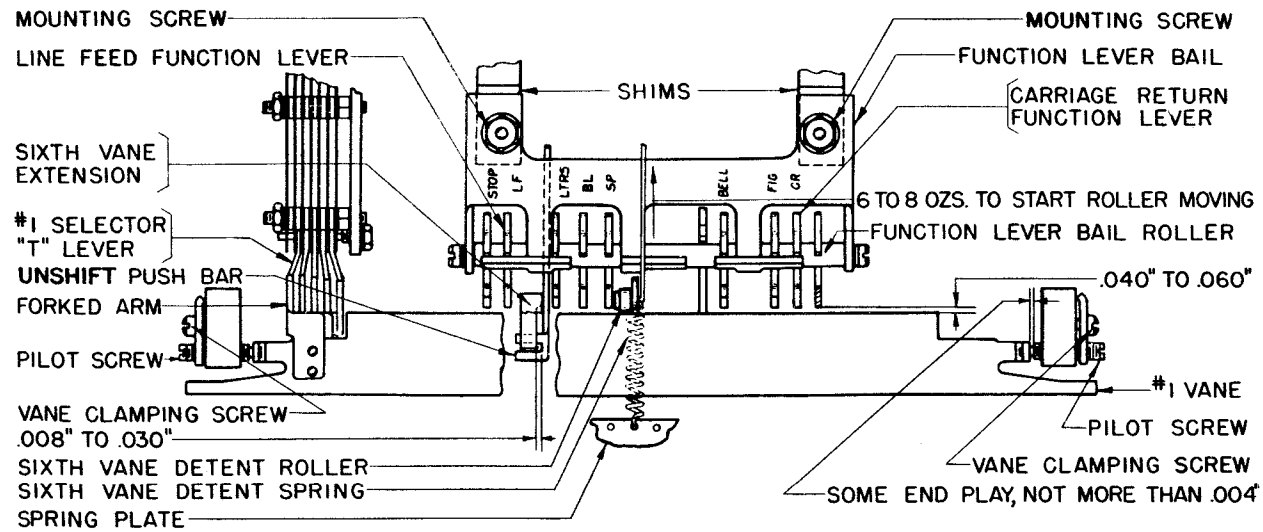

FIGURE 25

ORIGINAL

138B

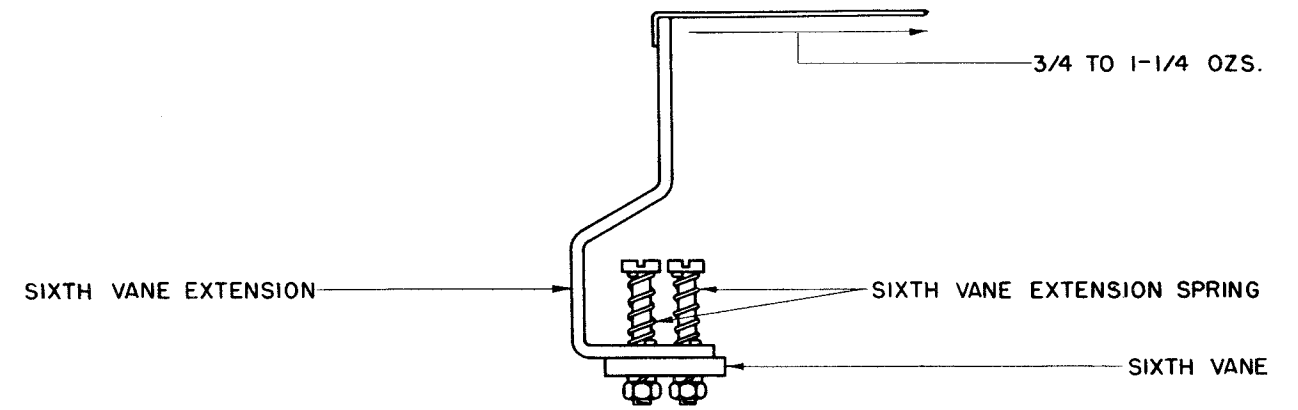

FIGURE 26

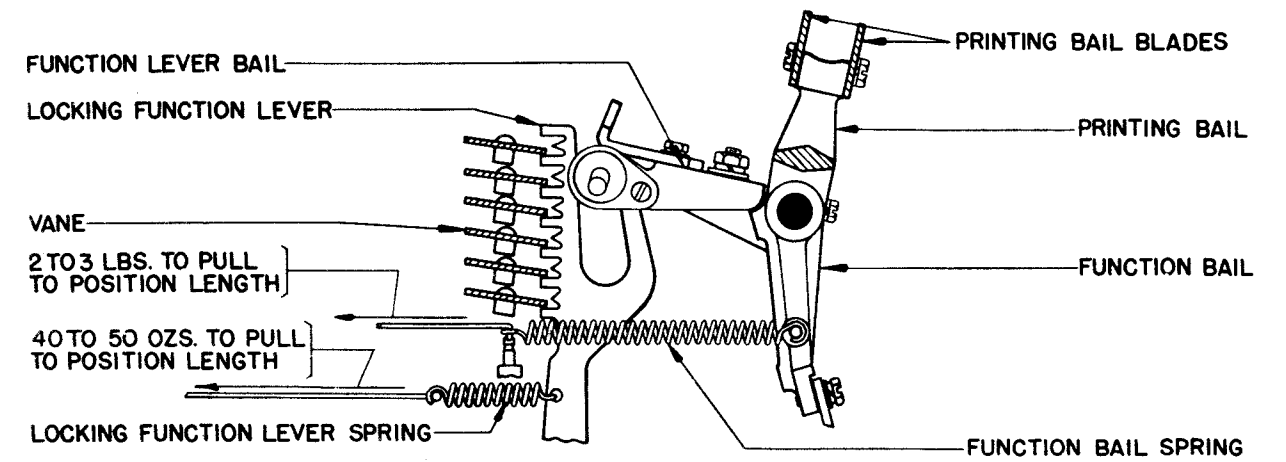

FIGURE 27

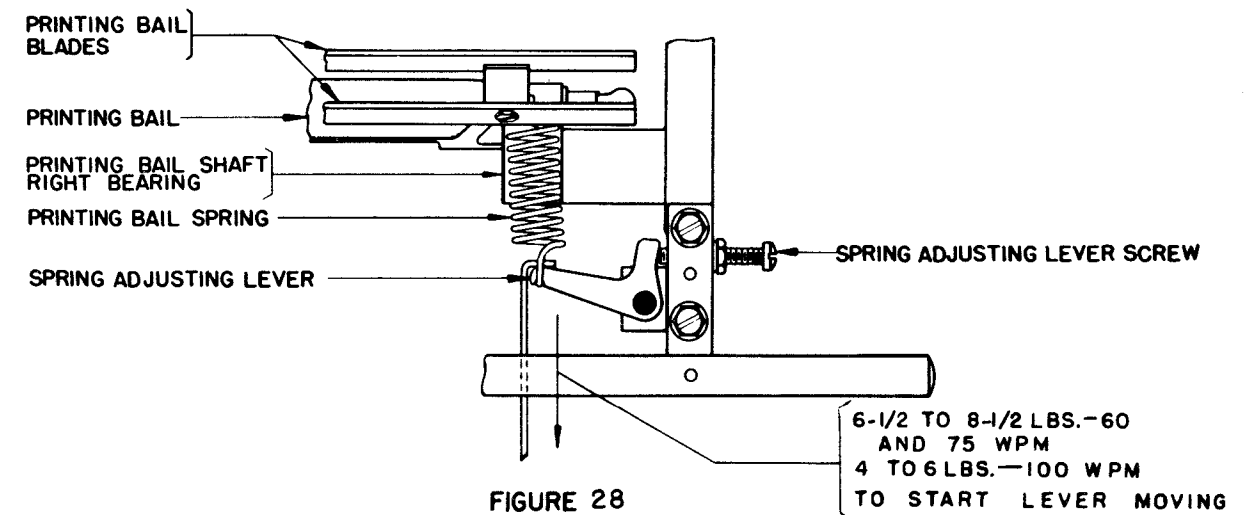

FIGURE 28

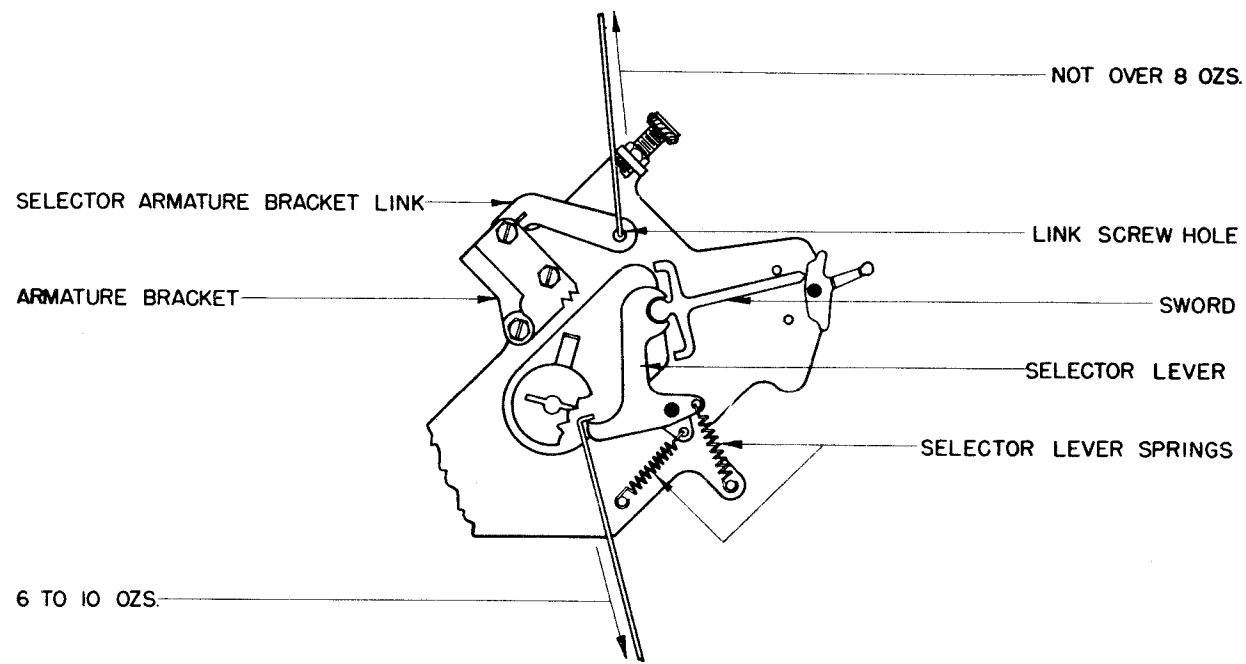

FIGURE 29

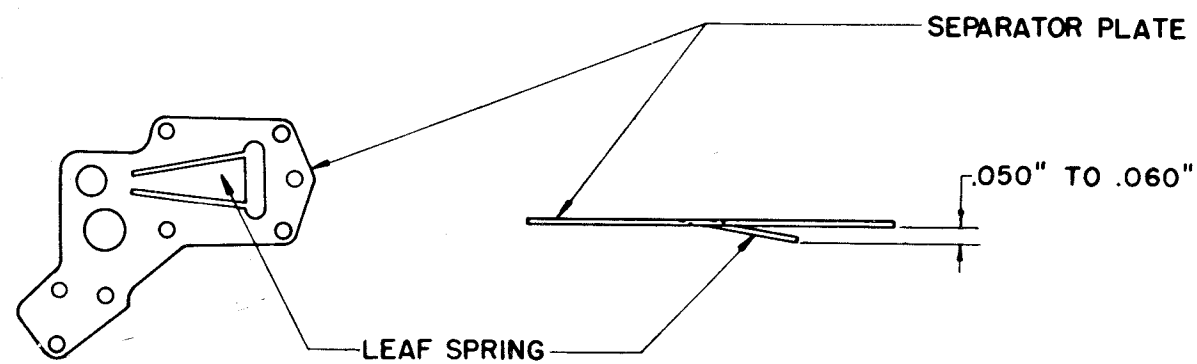

FIGURE 30

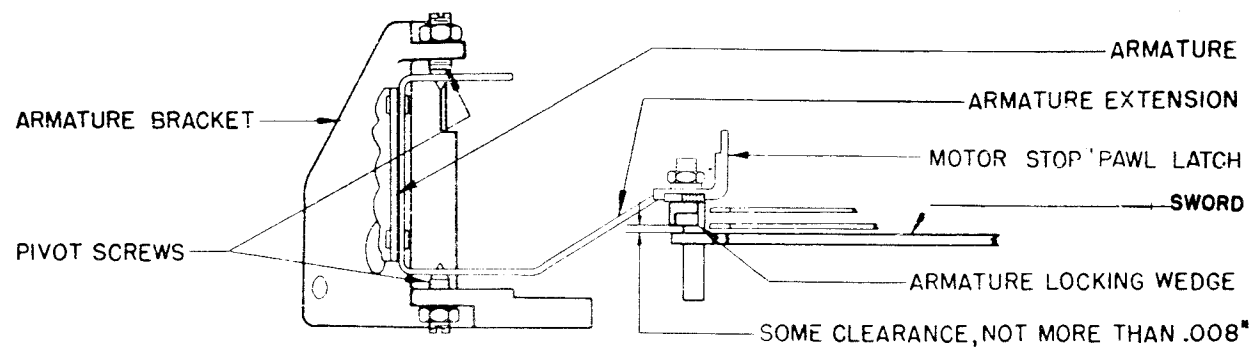

FIGURE 31

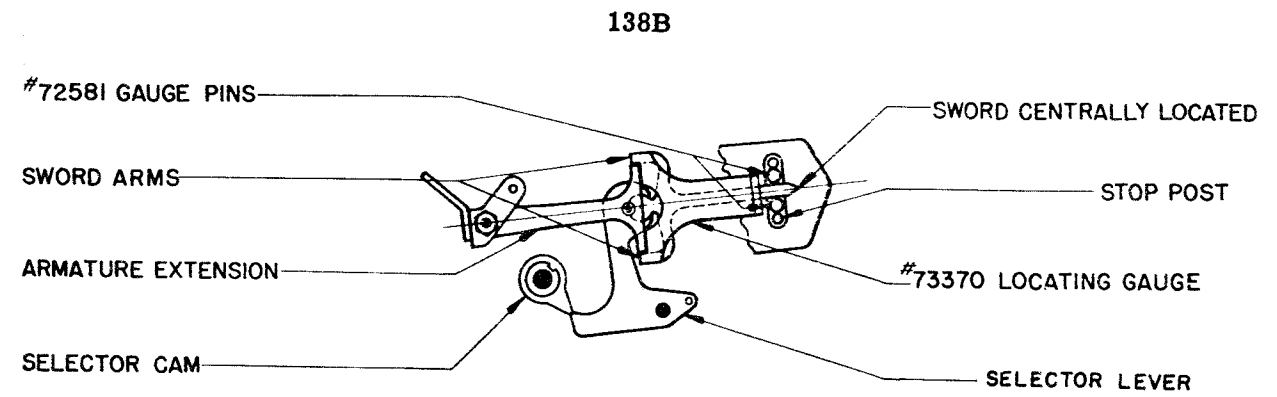

FIGURE 32

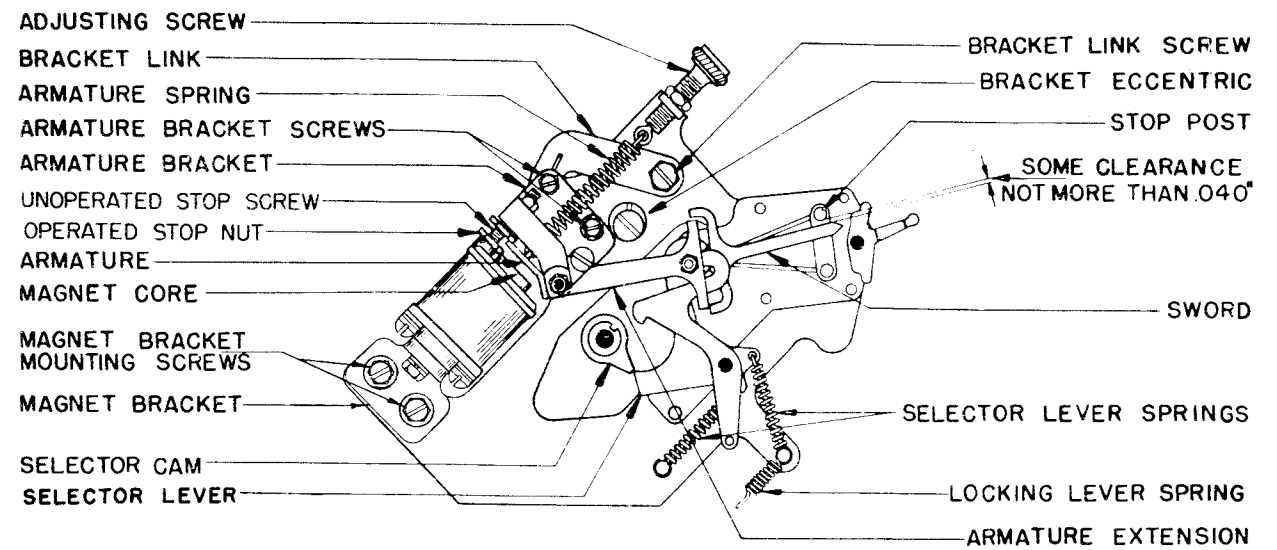

FIGURE 33

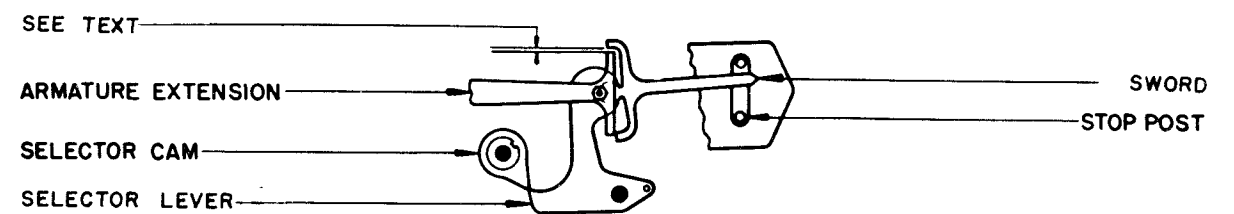

FIGURE 34

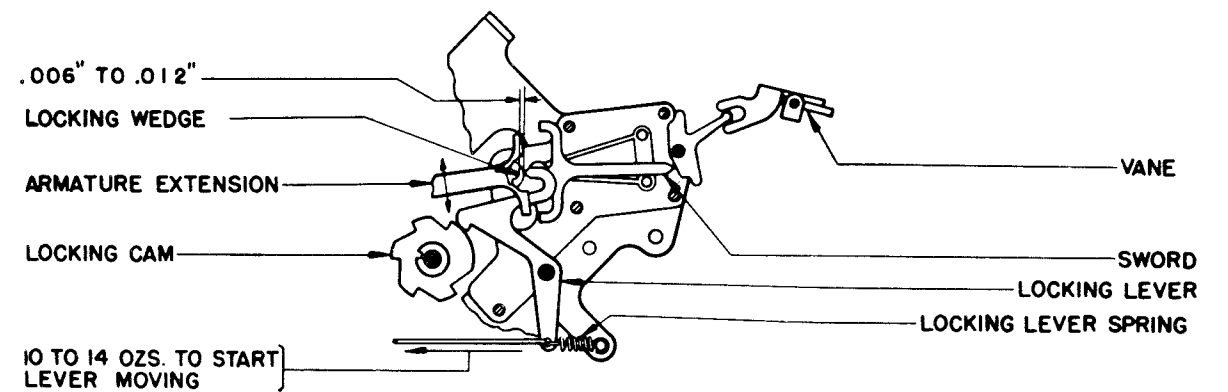

FIGURE 35

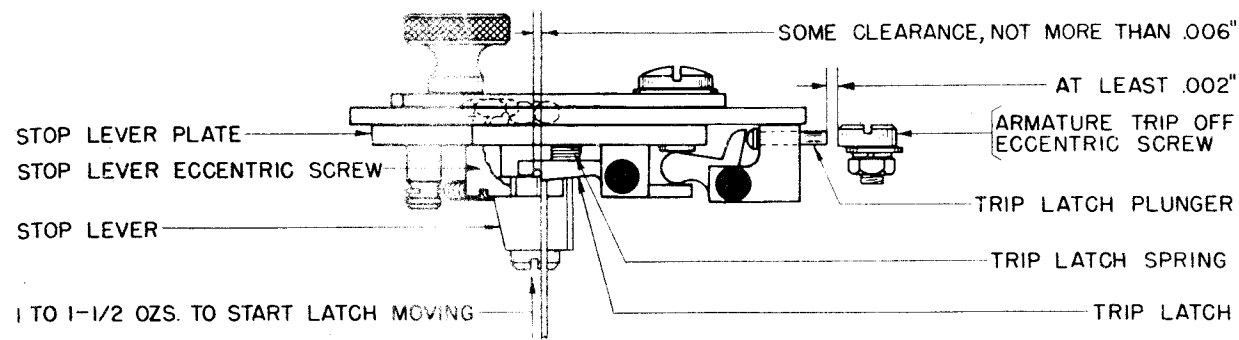

FIGURE 36

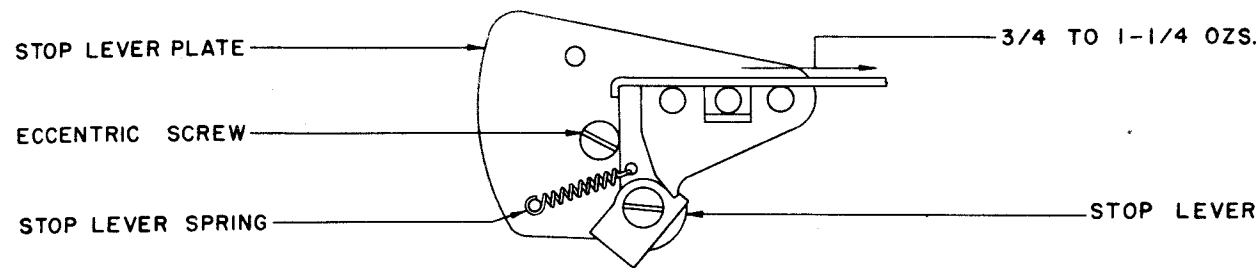

FIGURE 37

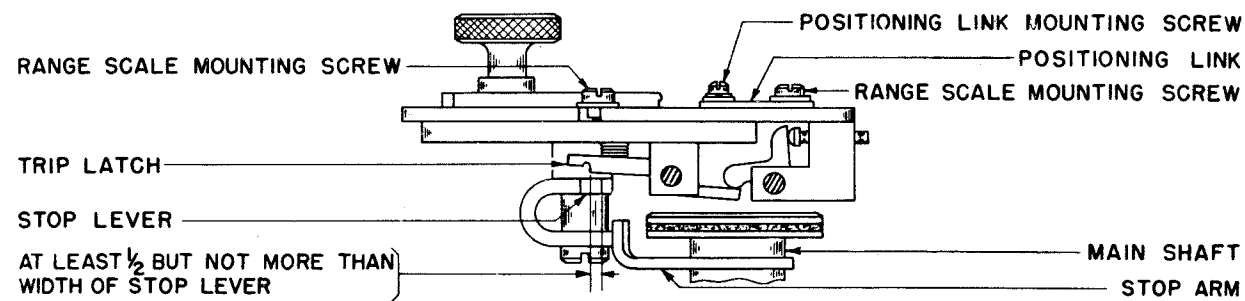

FIGURE 38

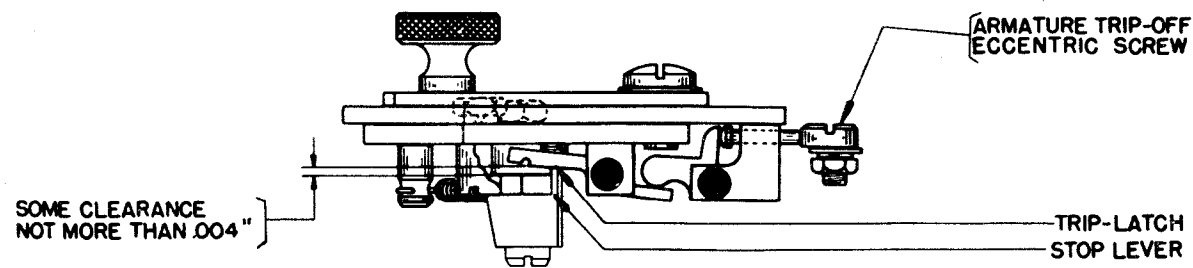

FIGURE 39

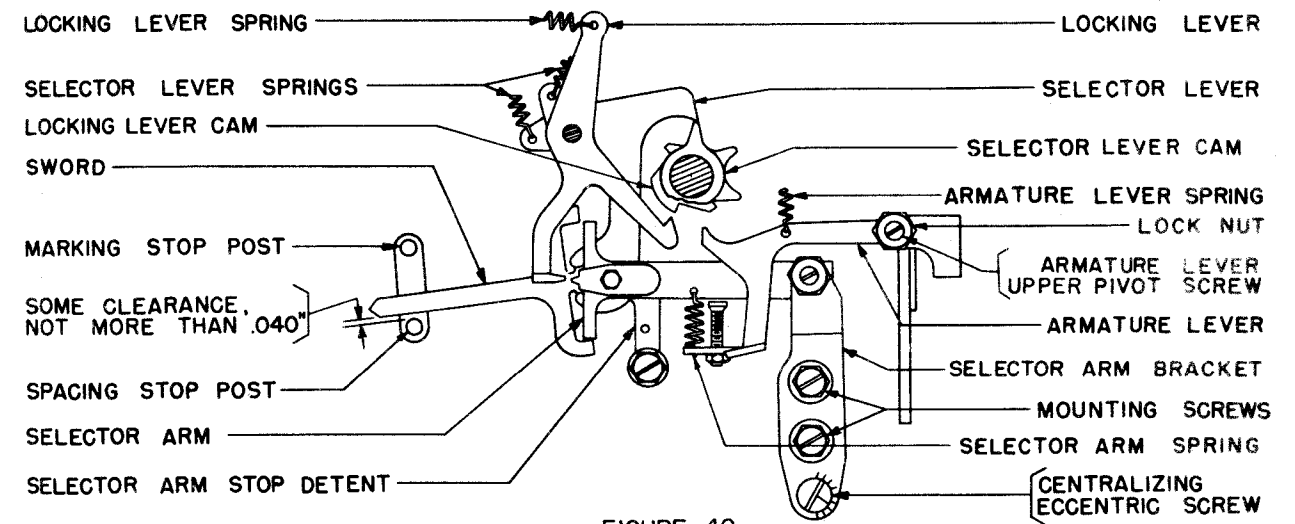

FIGURE 40

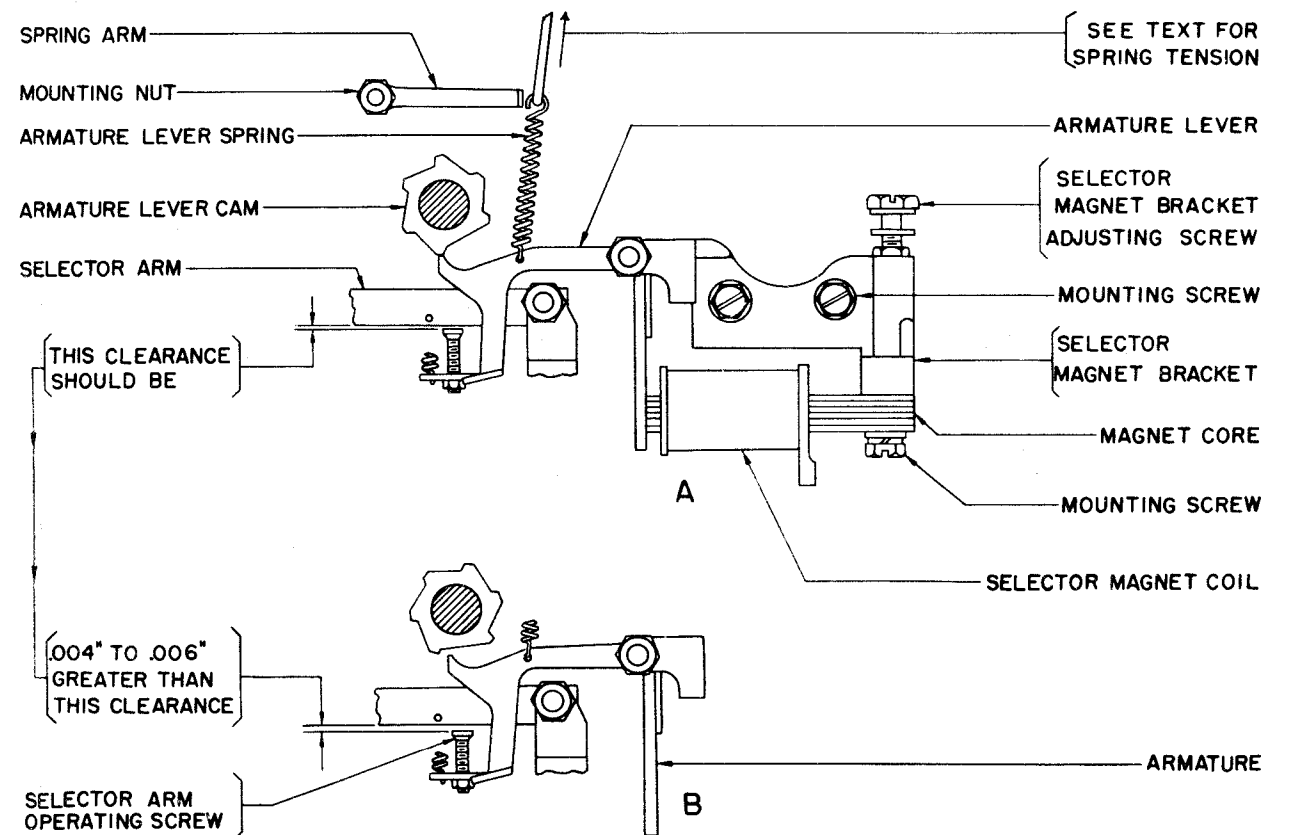

FIGURE 41

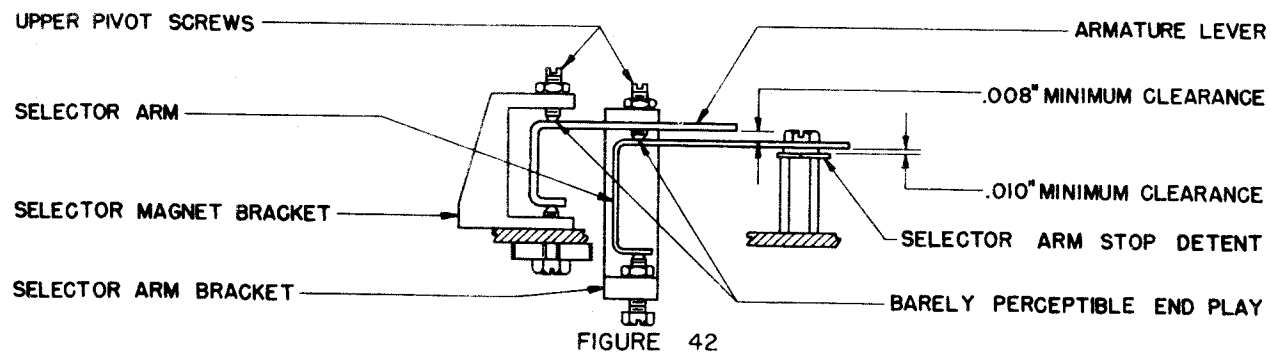
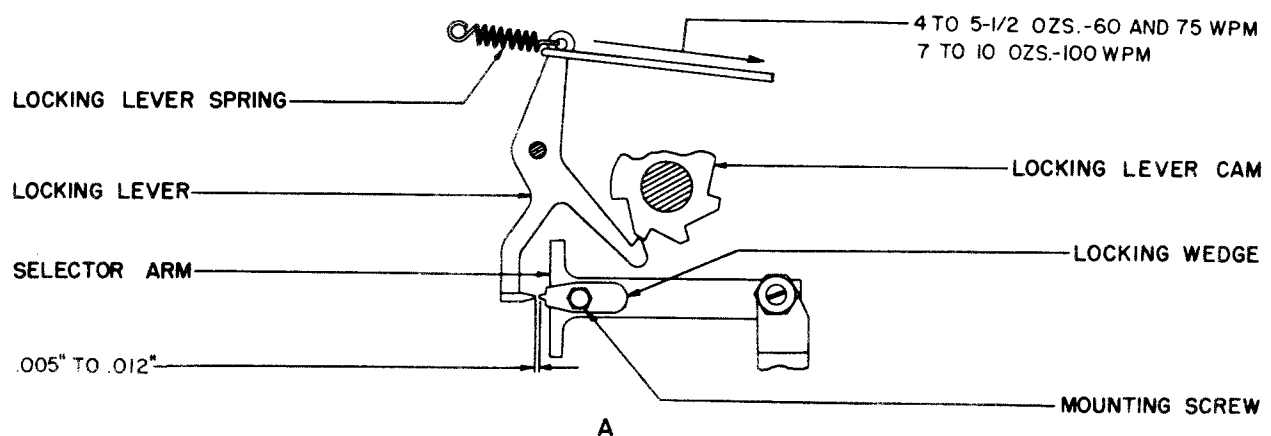
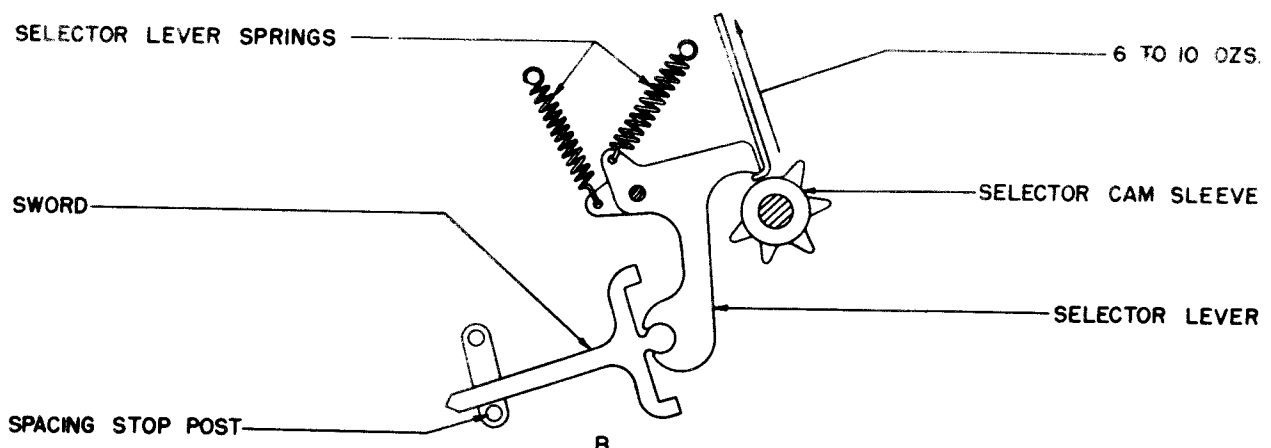

FIGURE 42



A



B

FIGURE 43

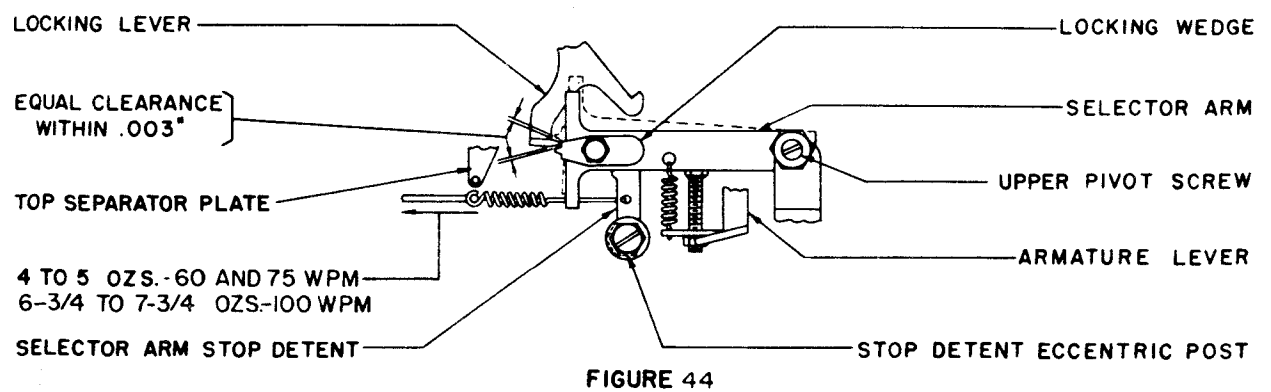

FIGURE 44

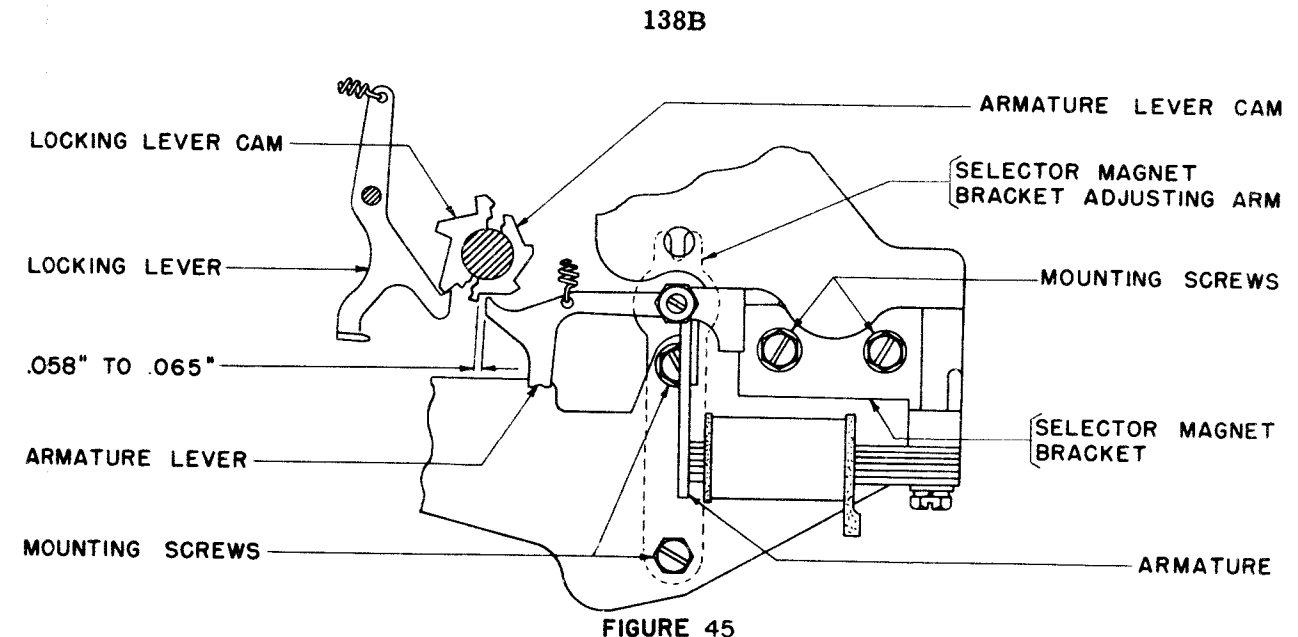

FIGURE 45

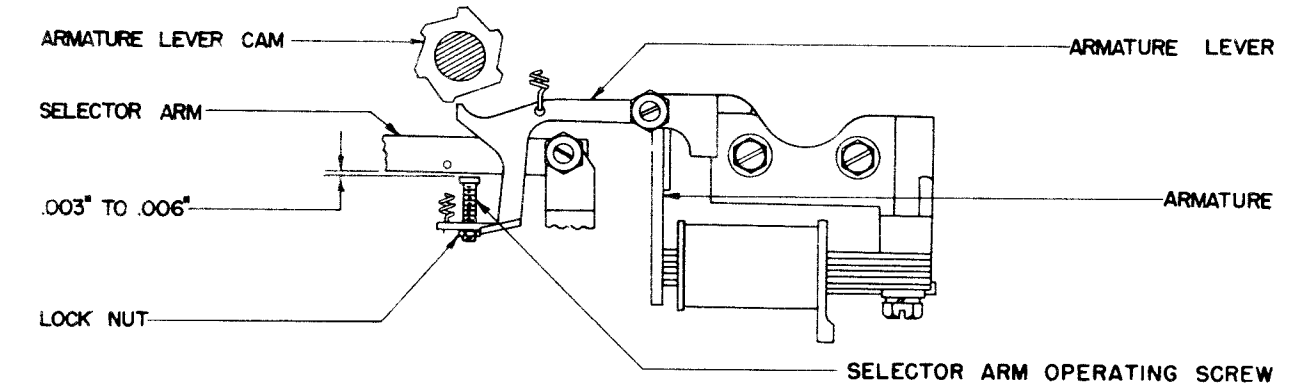

FIGURE 46

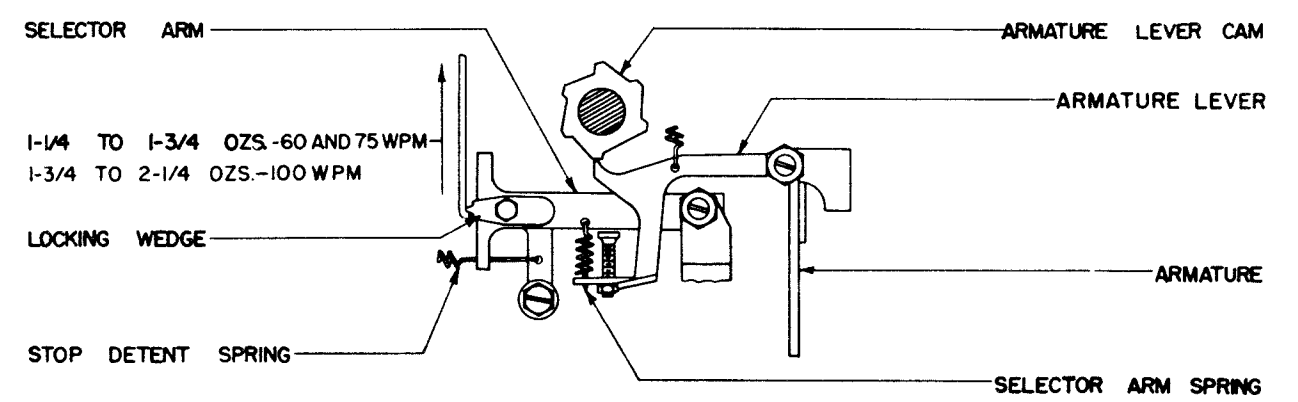

FIGURE 47

ORIGINAL

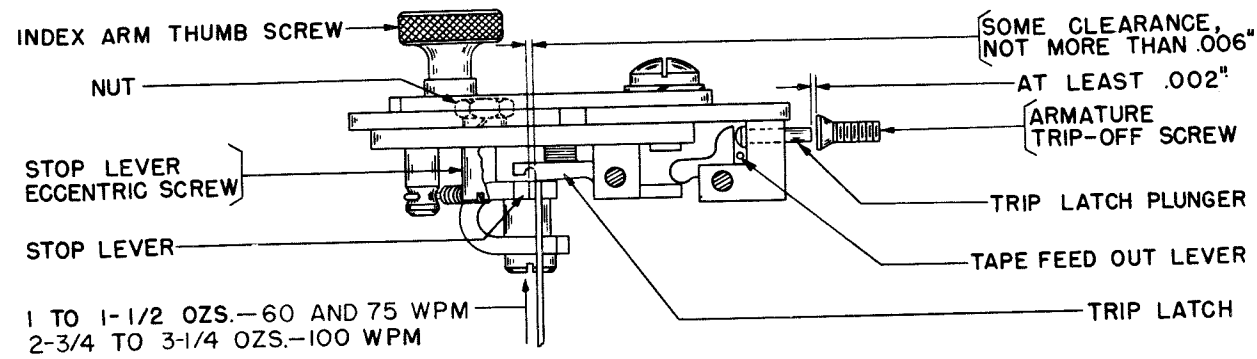

FIGURE 48

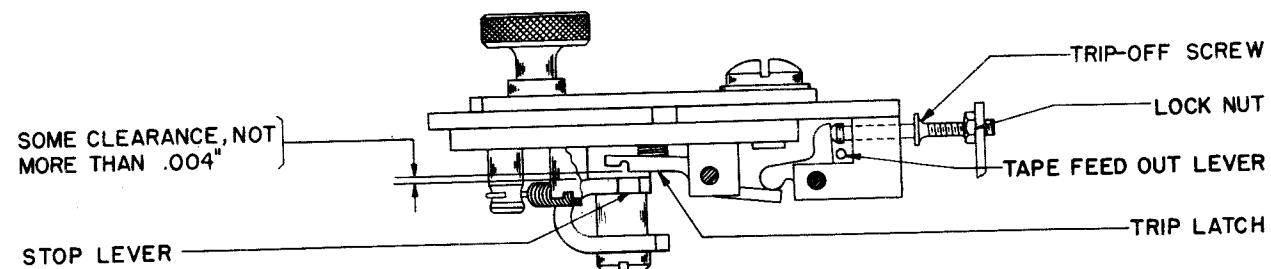

FIGURE 49

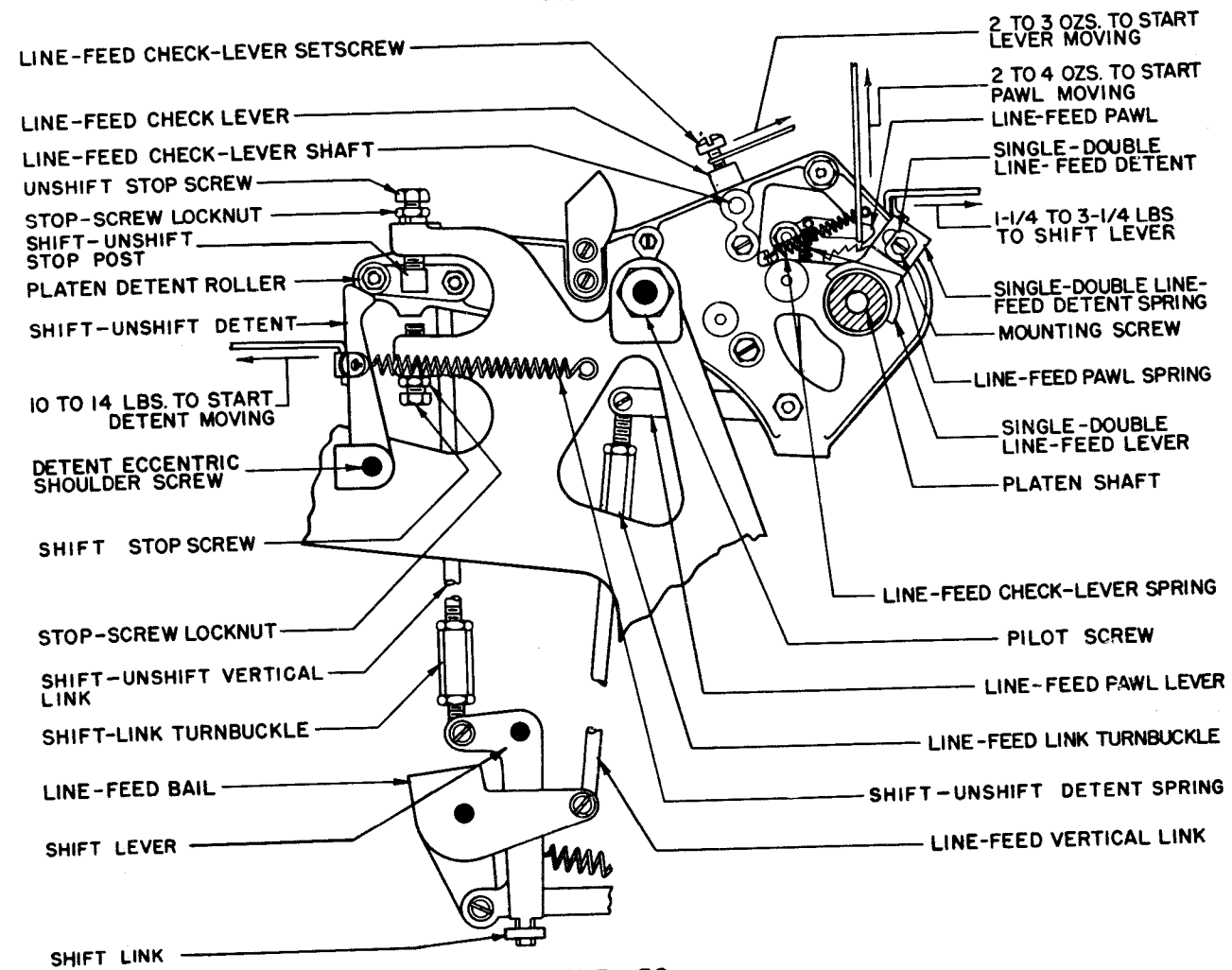

FIGURE 50

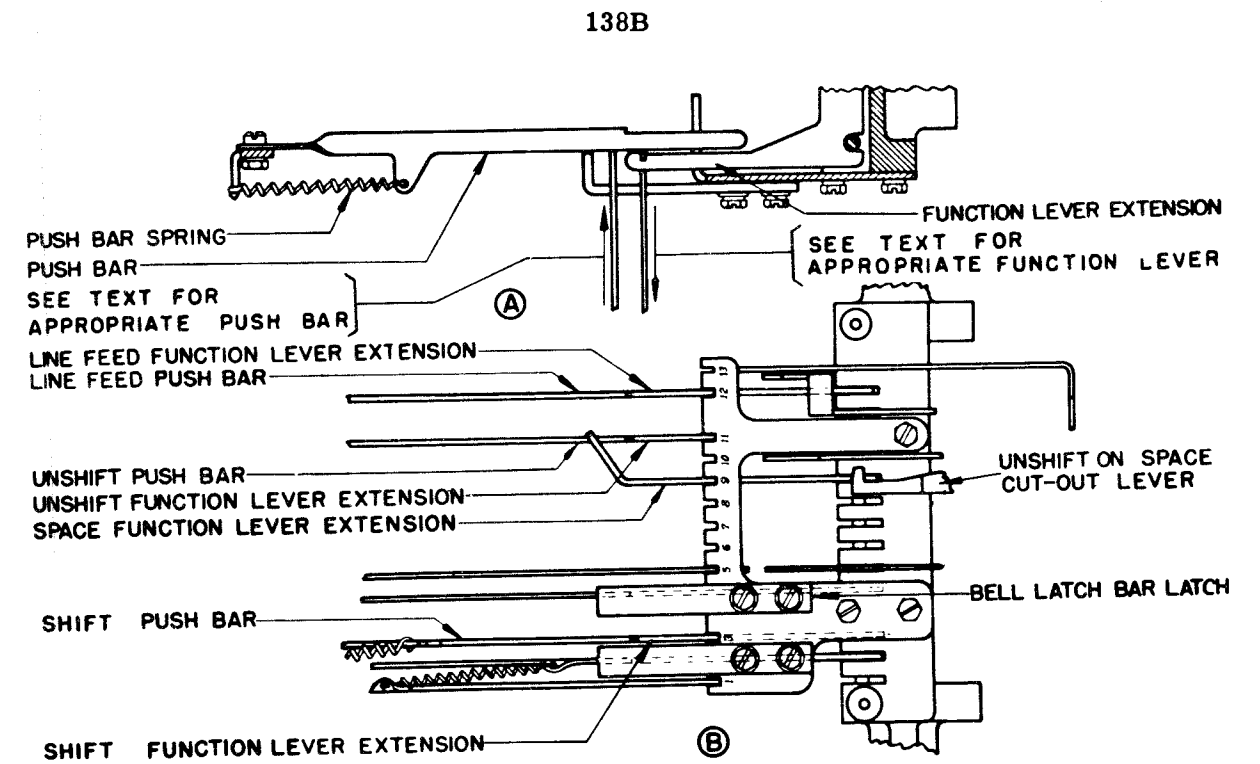

FIGURE 51

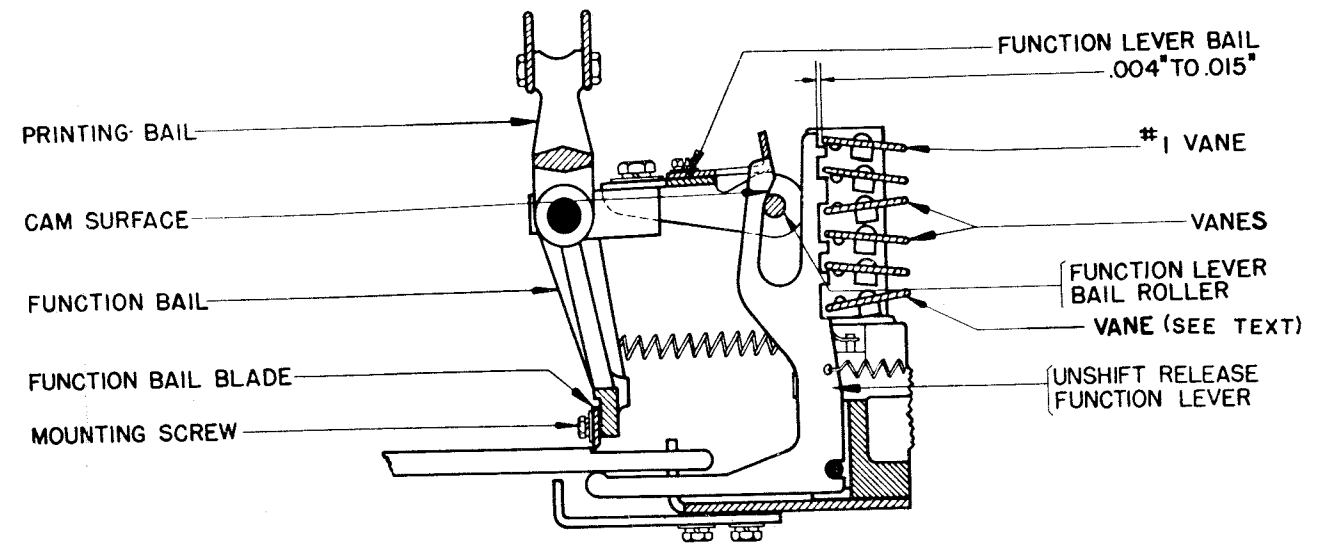

FIGURE 52

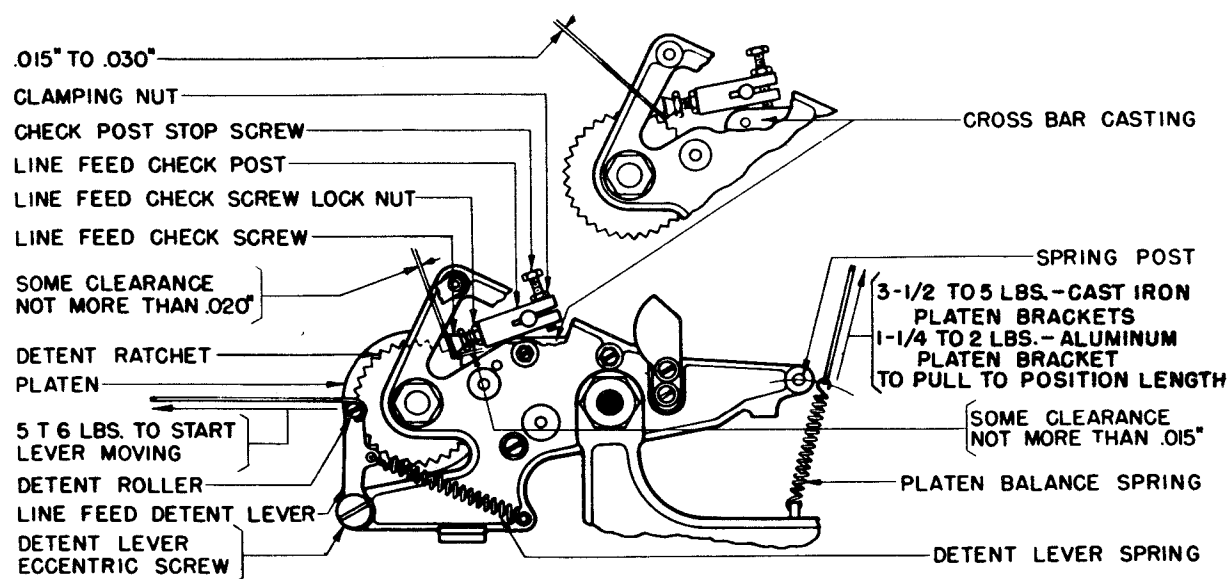

FIGURE 53

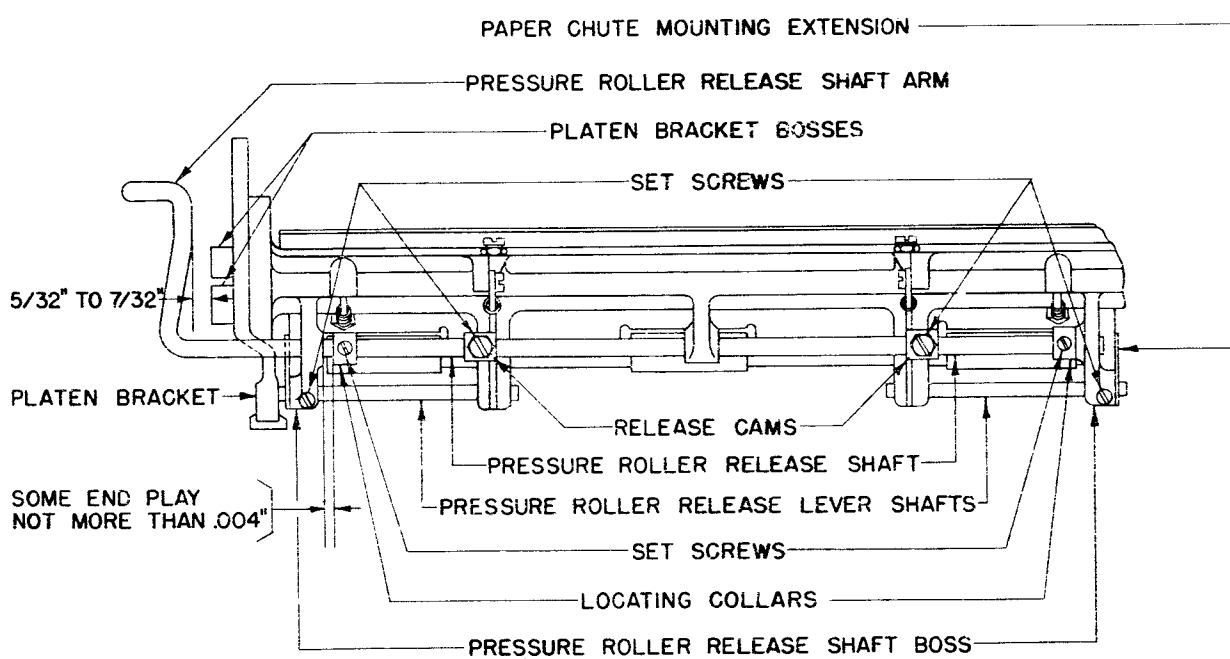

FIGURE 54

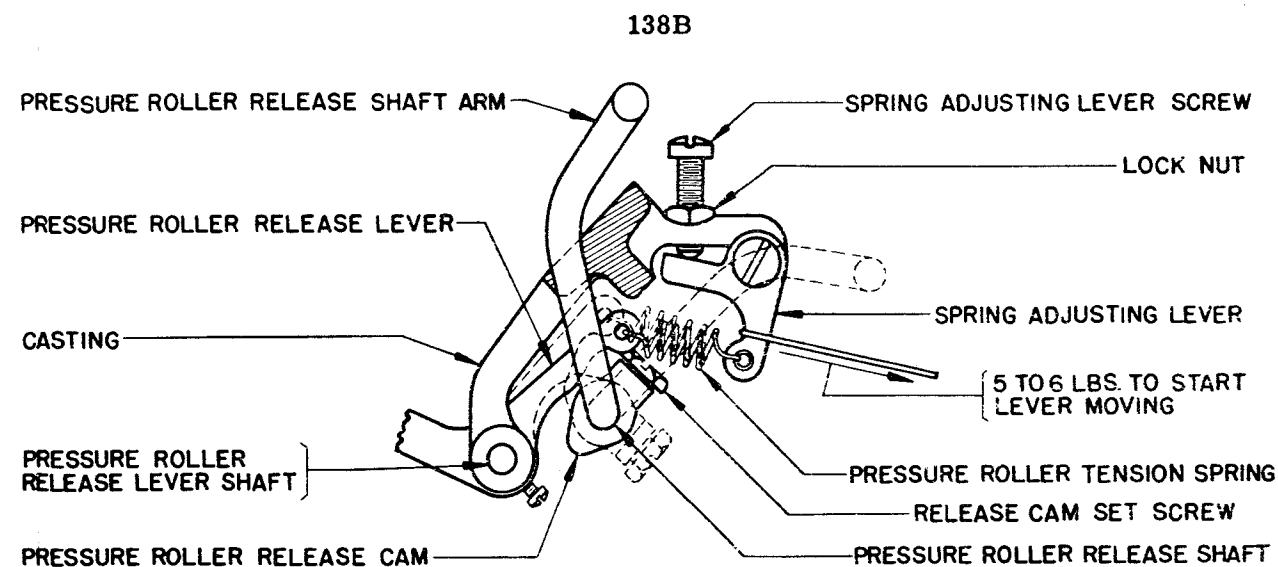
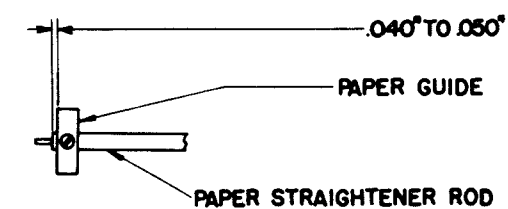
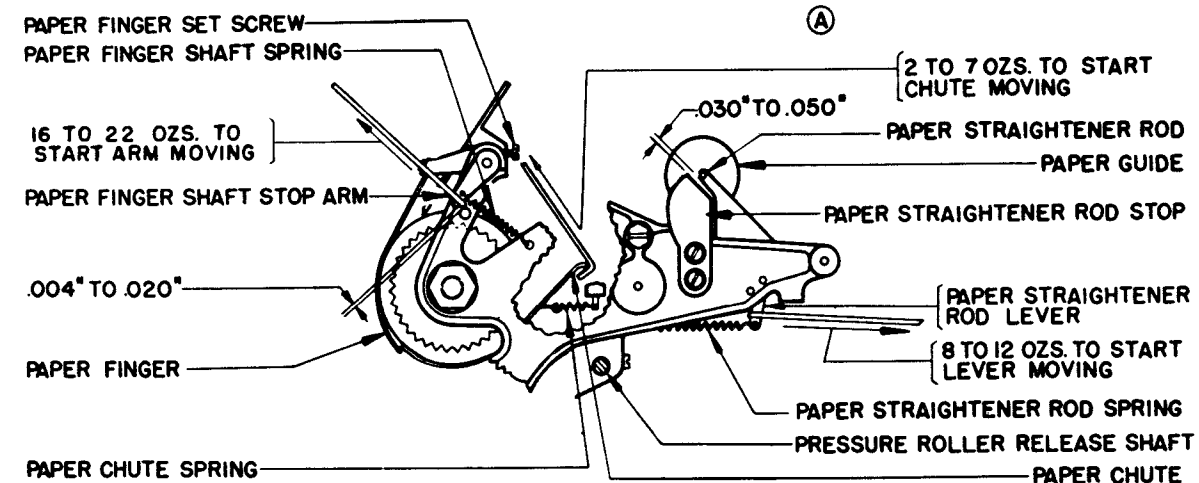

FIGURE 55



(A)



(B)

FIGURE 56

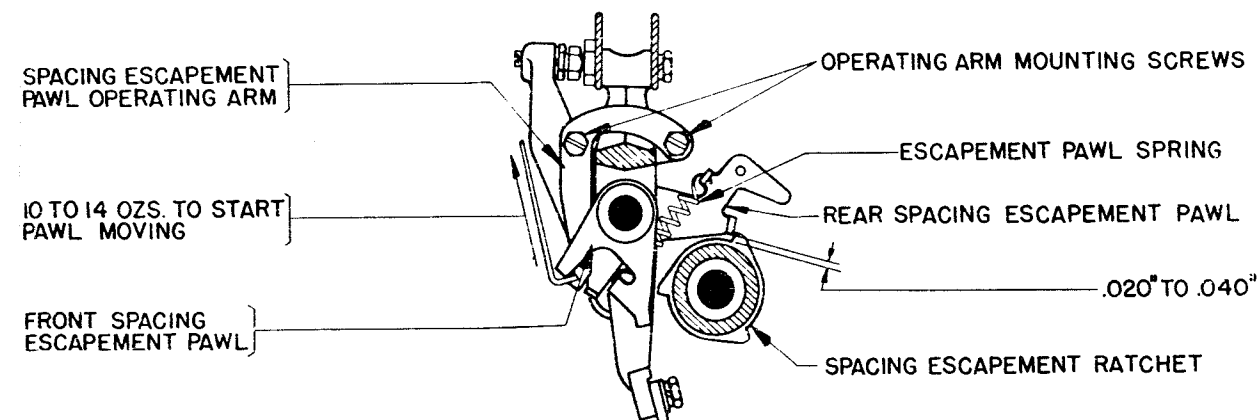

FIGURE 57

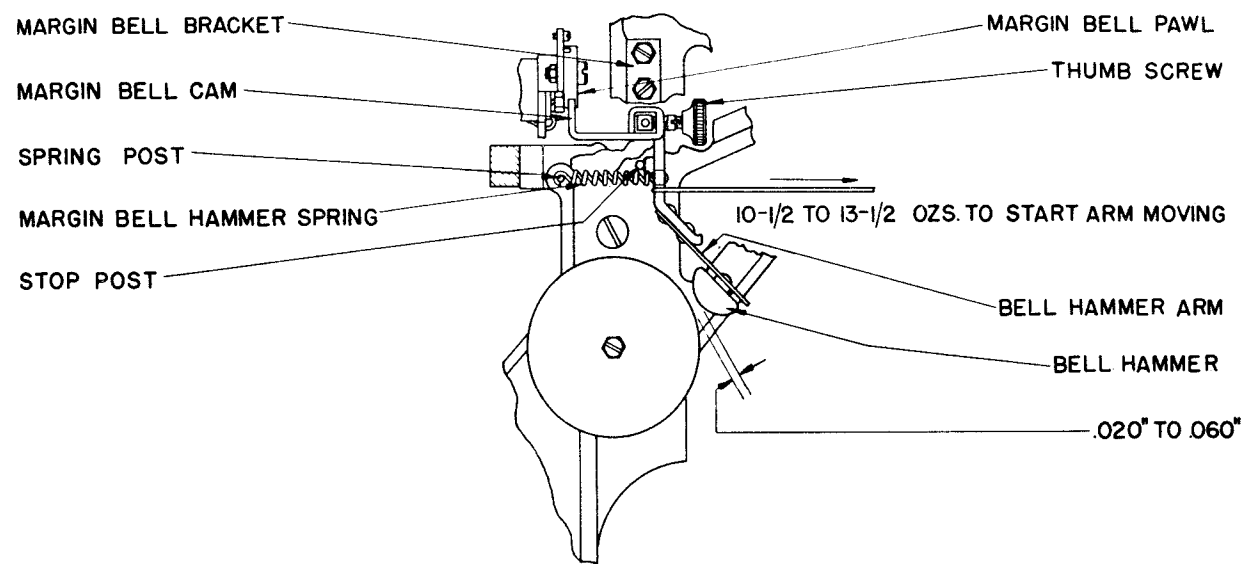

FIGURE 58

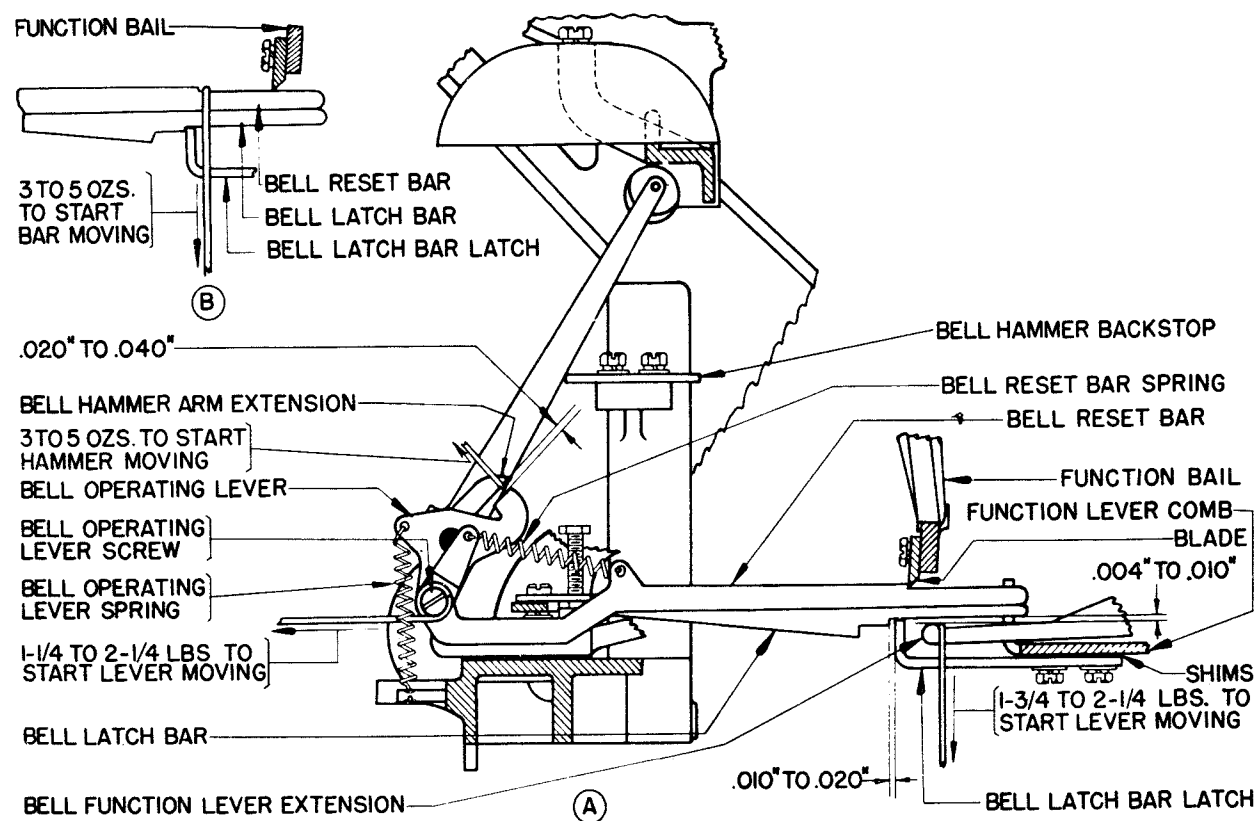

FIGURE 59

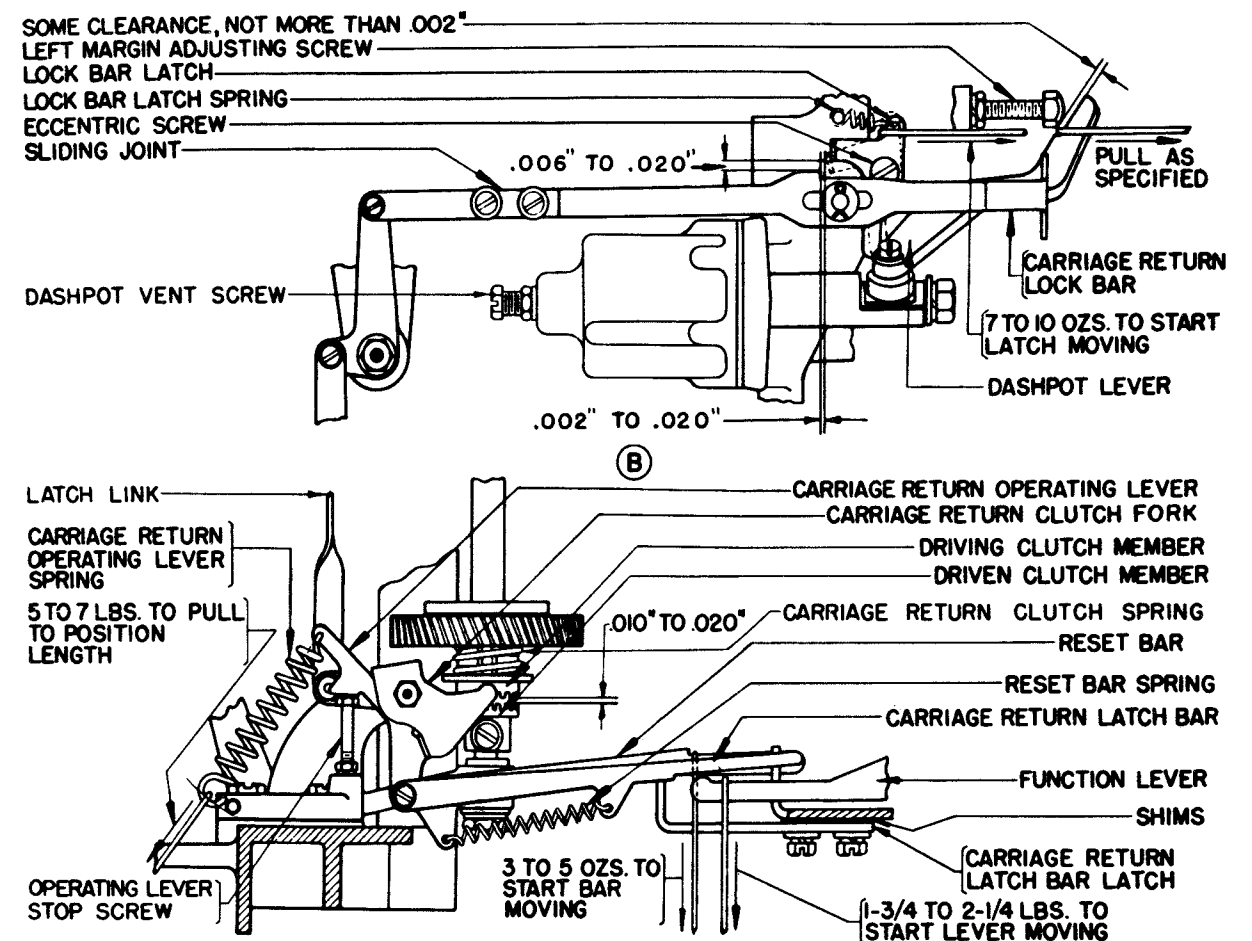

FIGURE 60

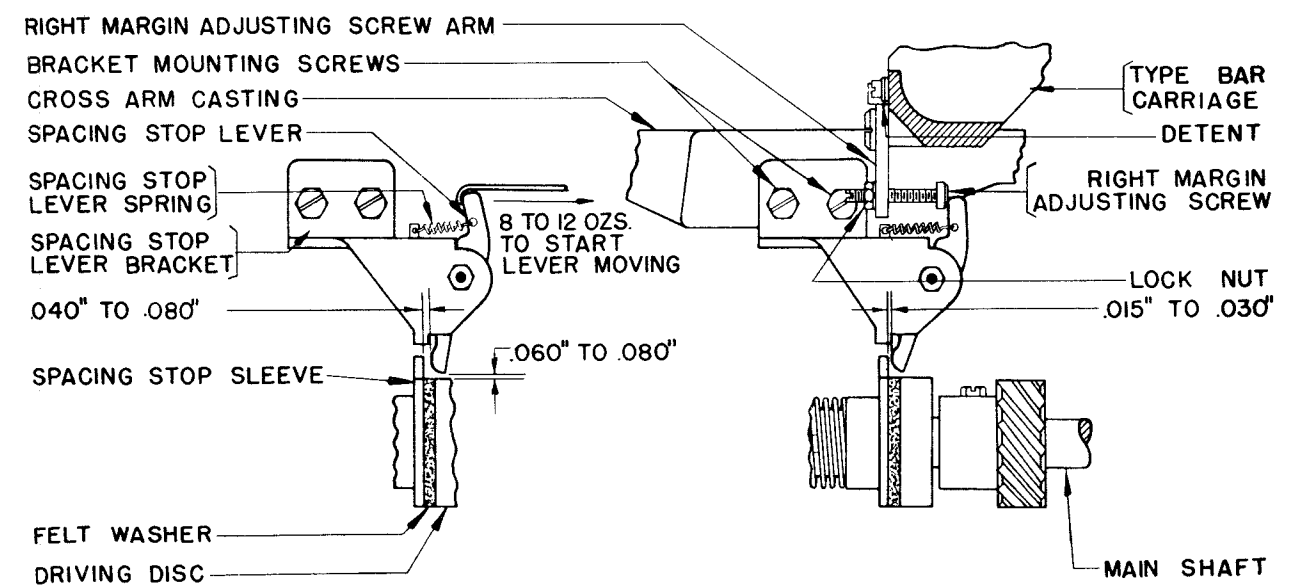

FIGURE 61

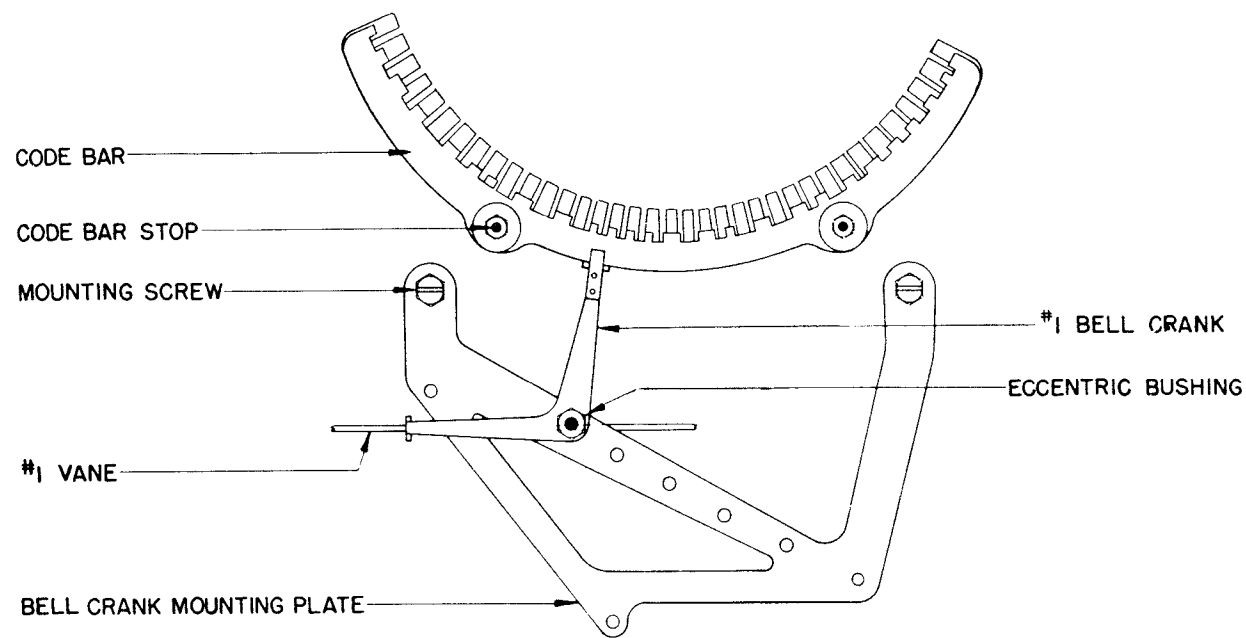

FIGURE 62

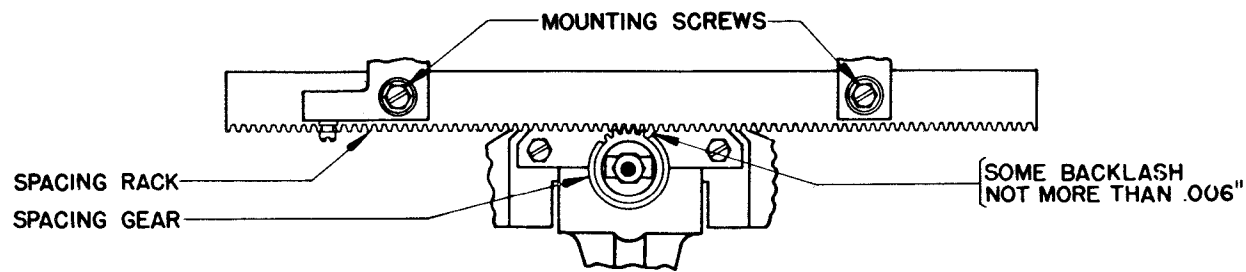

FIGURE 63

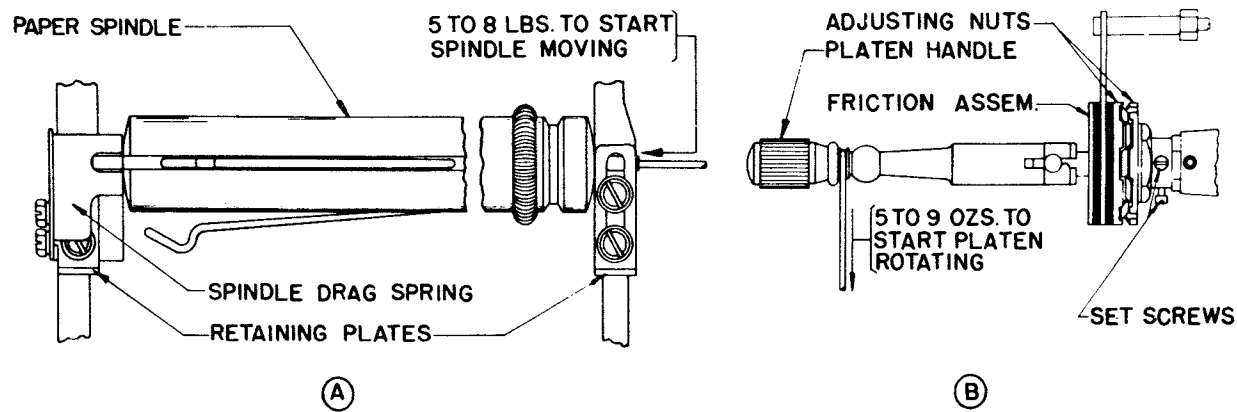

FIGURE 64

138B

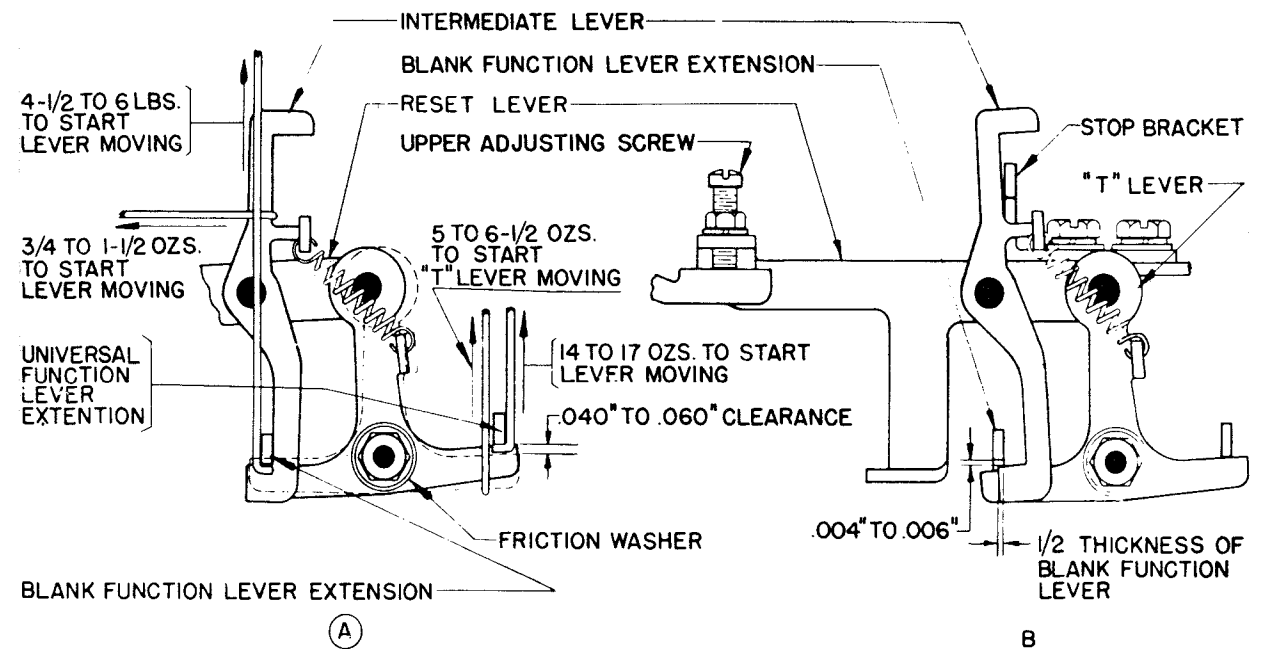

FIGURE 65

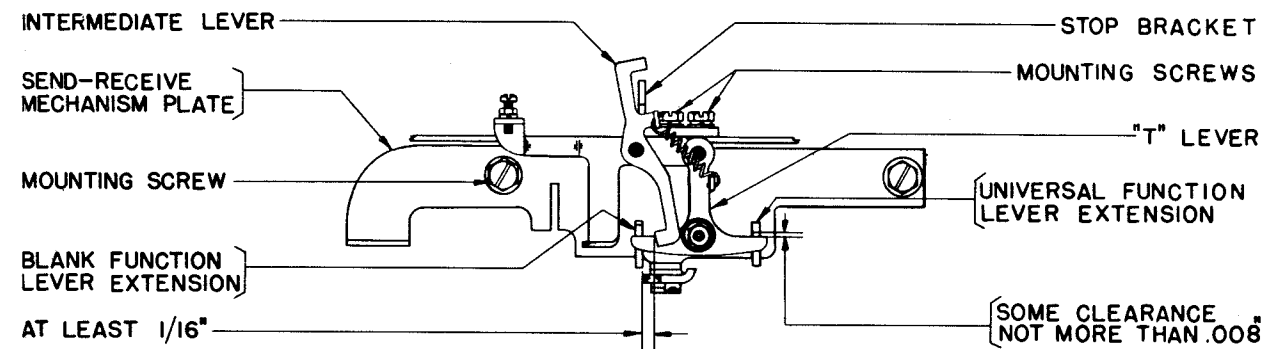

FIGURE 66

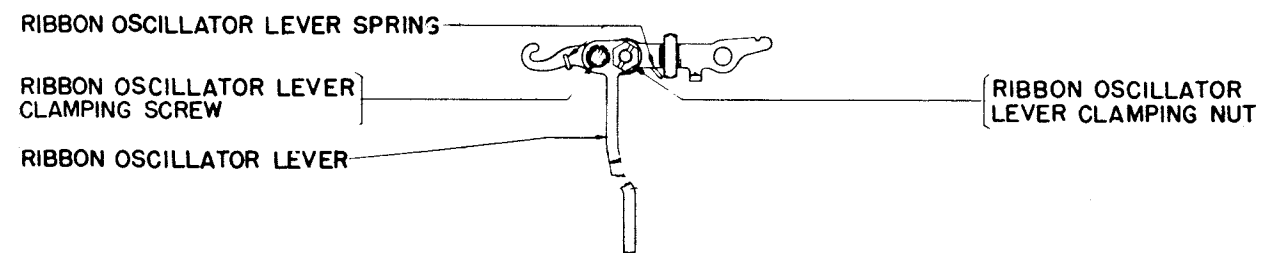

FIGURE 67

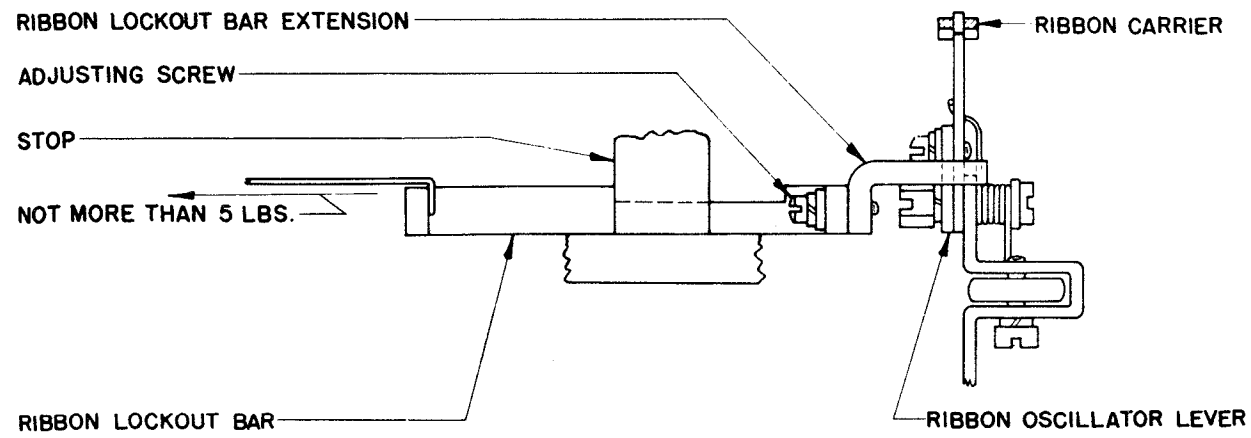

FIGURE 68

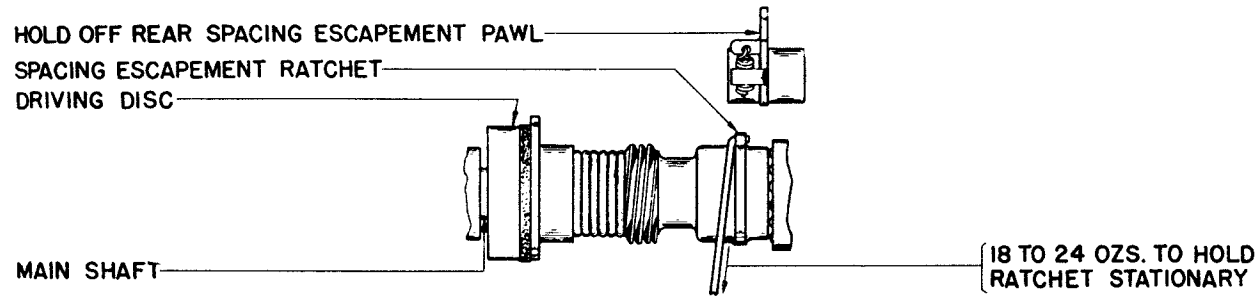

FIGURE 69

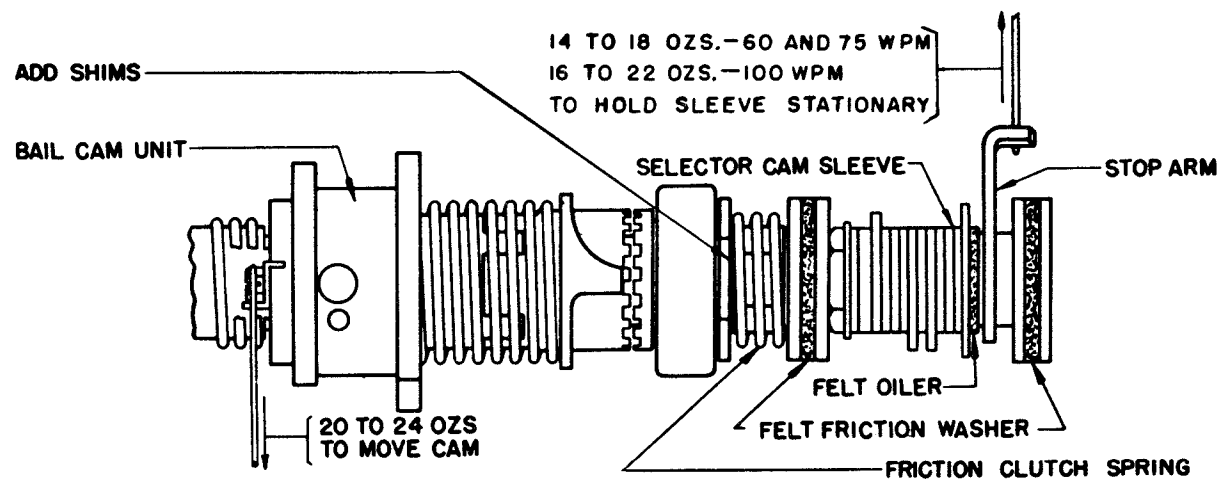

FIGURE 70

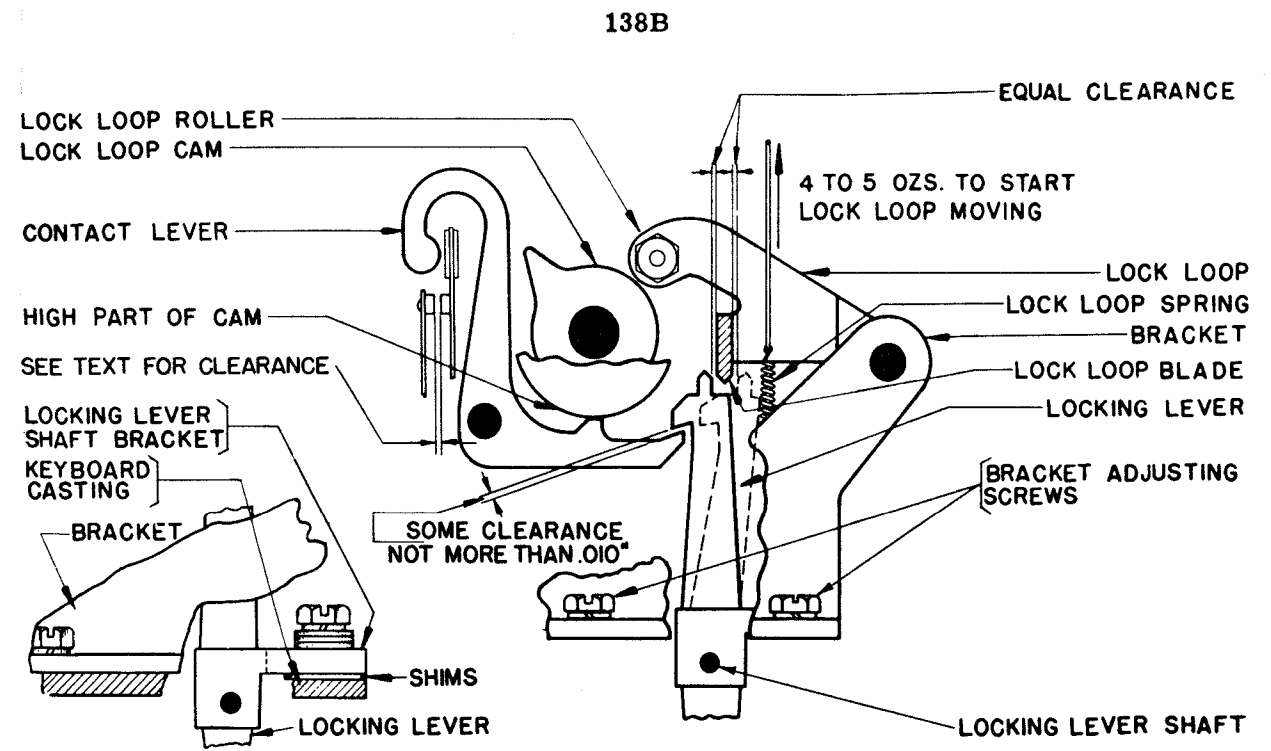

FIGURE 71

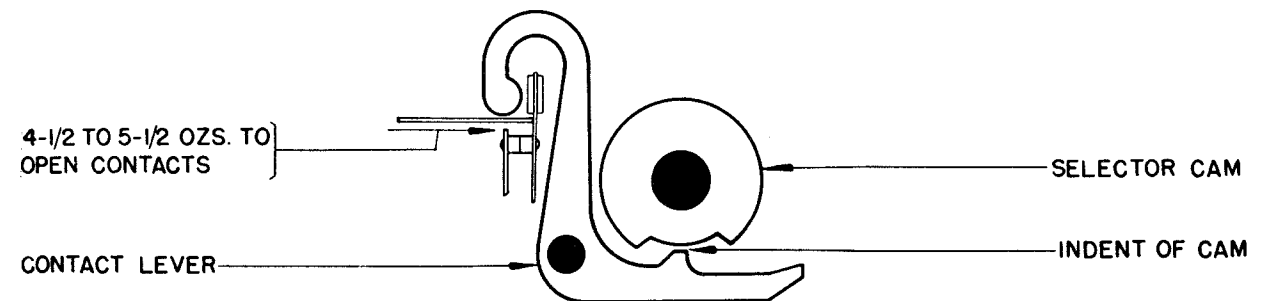

FIGURE 72

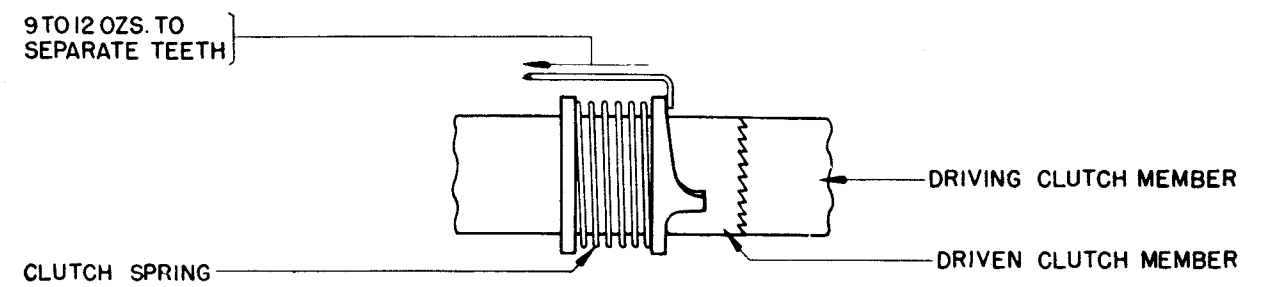

FIGURE 73

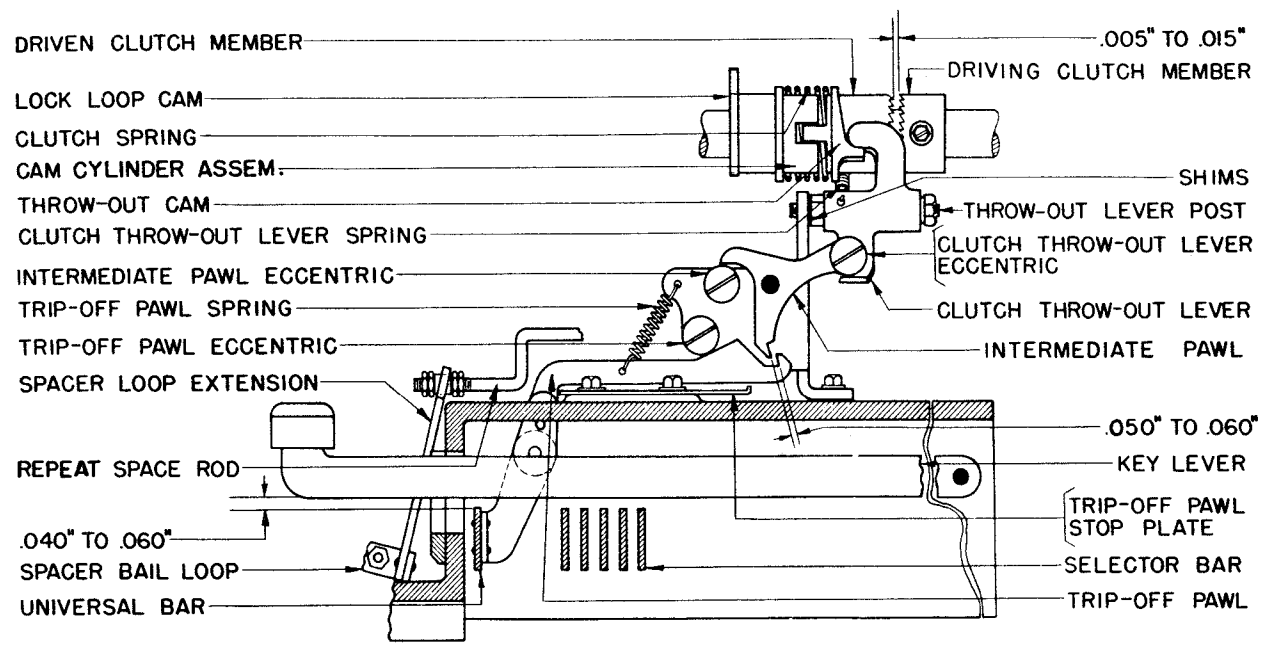

FIGURE 74

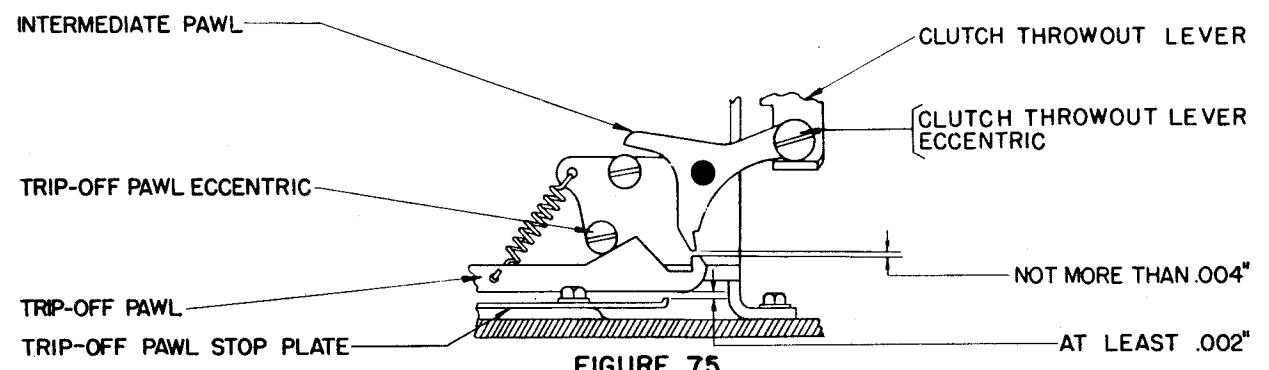

FIGURE 75

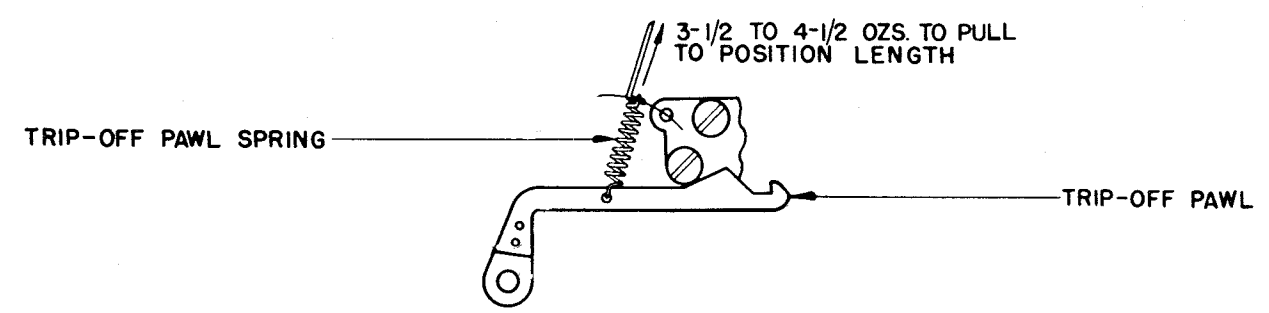

FIGURE 76

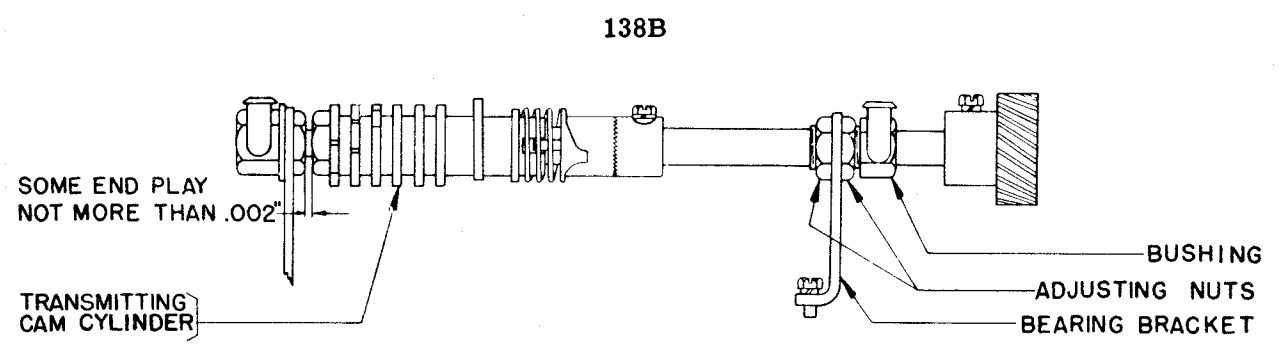

FIGURE 77

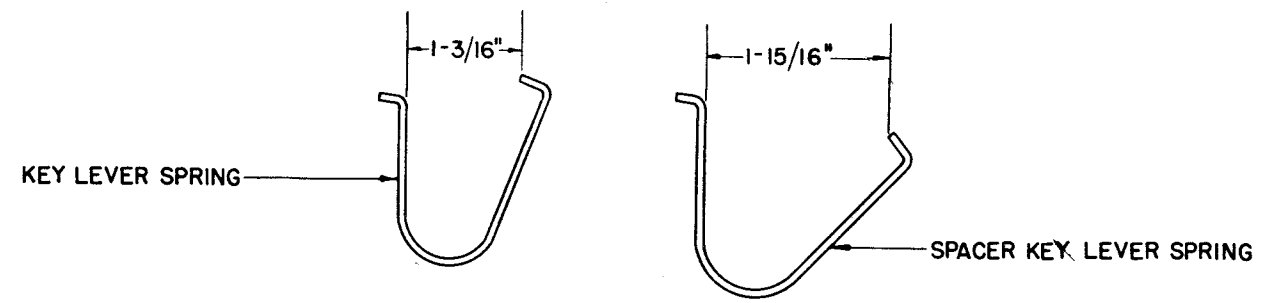

FIGURE 78

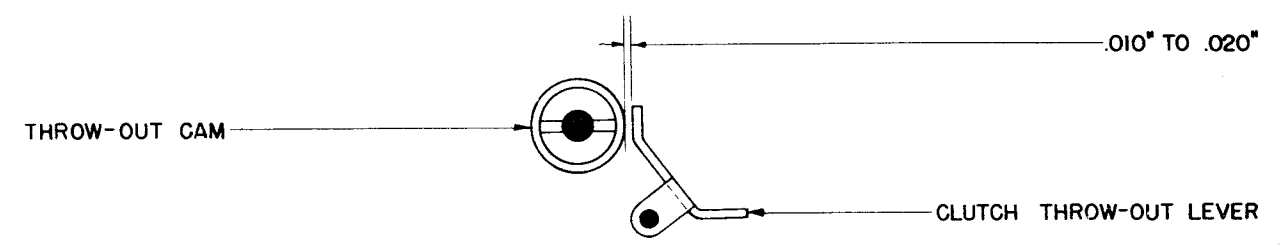

FIGURE 79

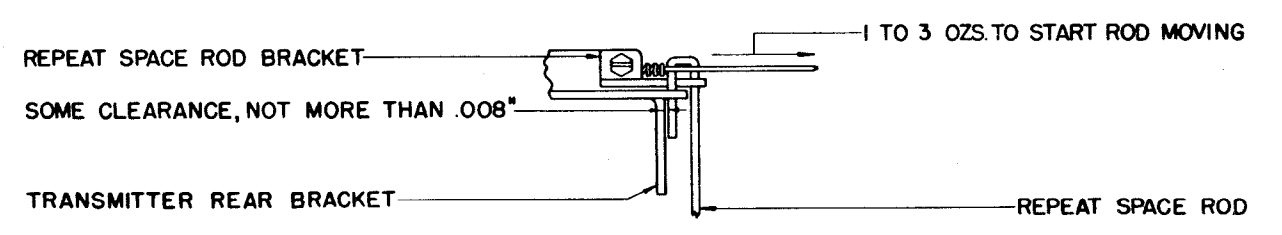

FIGURE 80

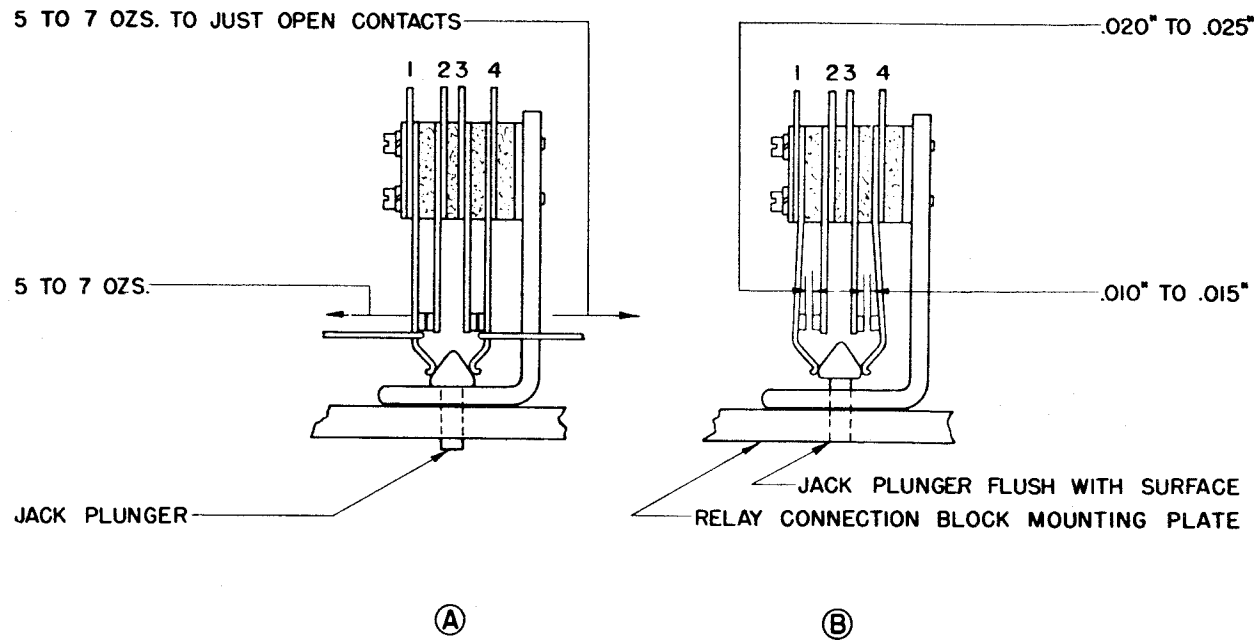

FIGURE 81

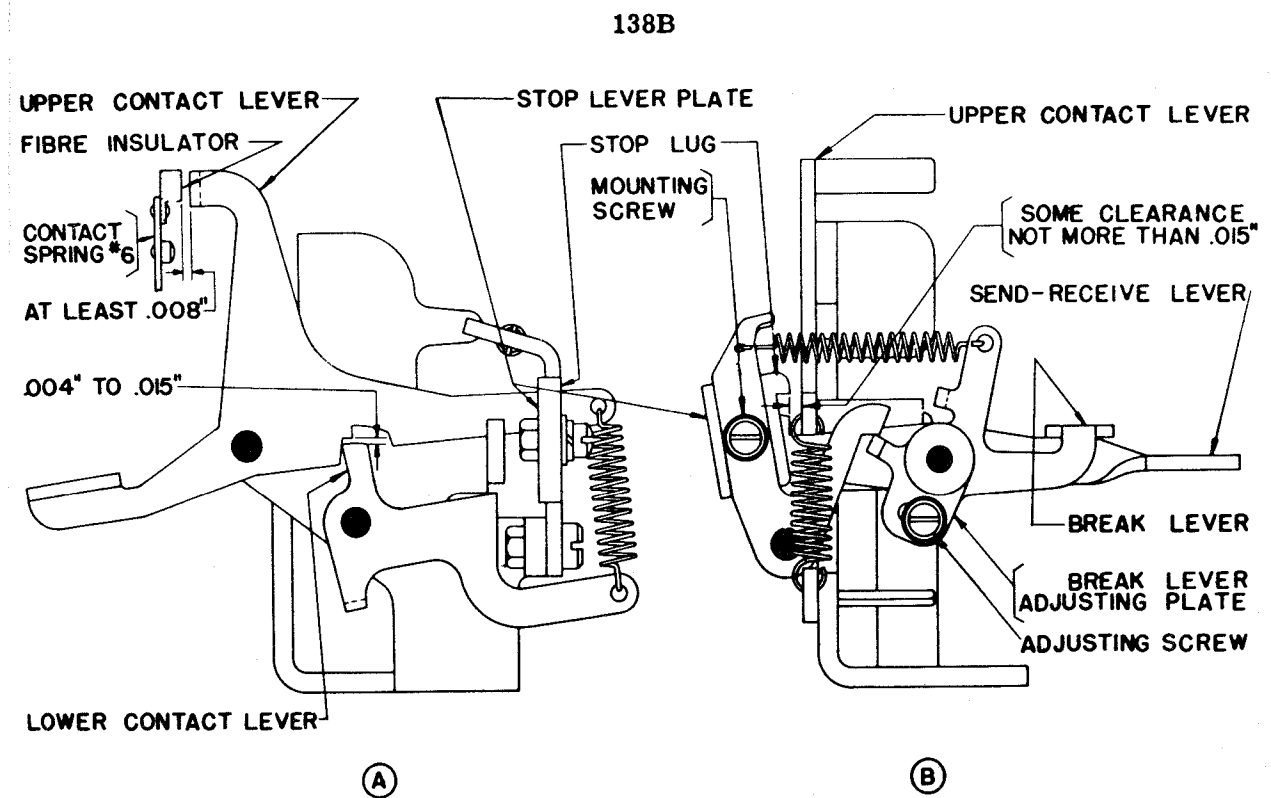

FIGURE 83

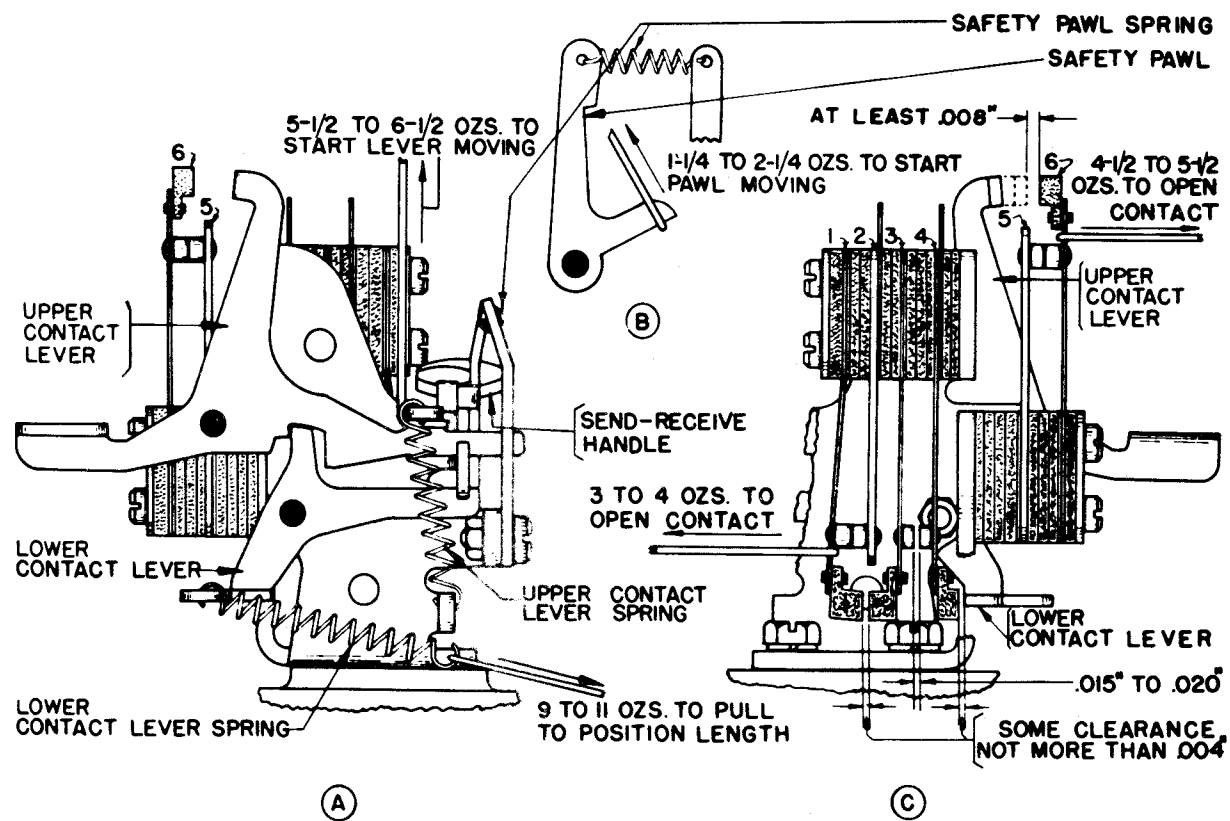

FIGURE 82

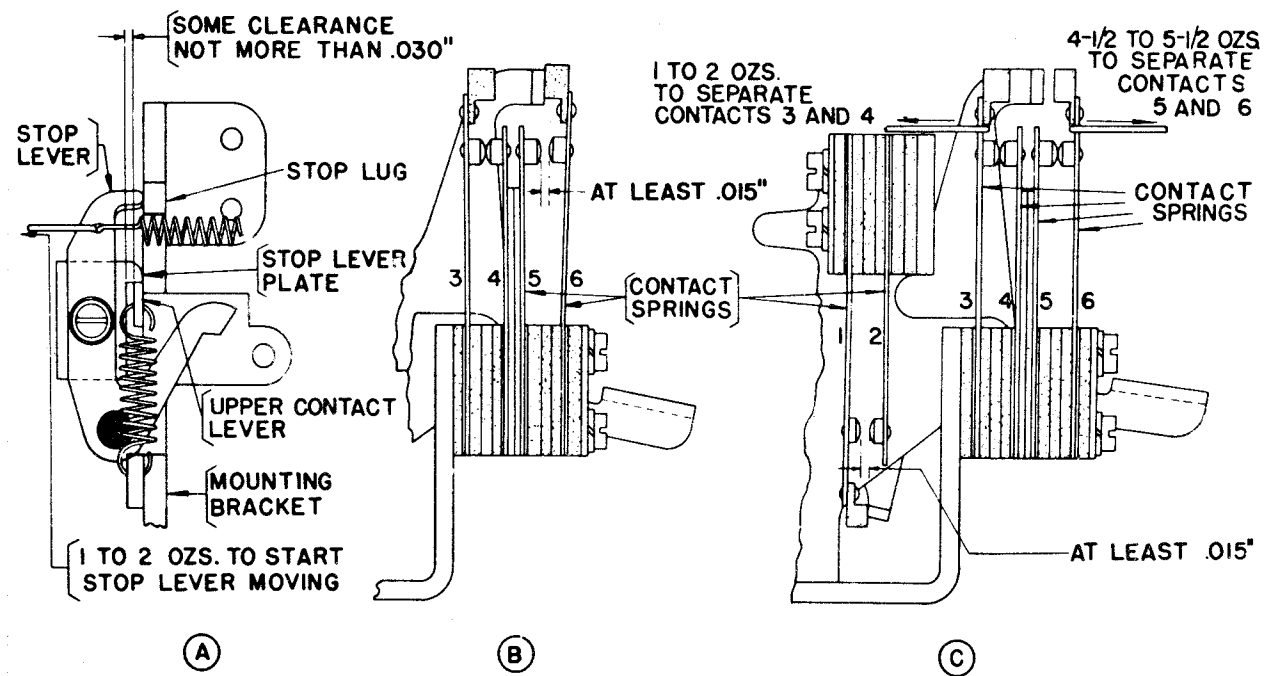

FIGURE 84

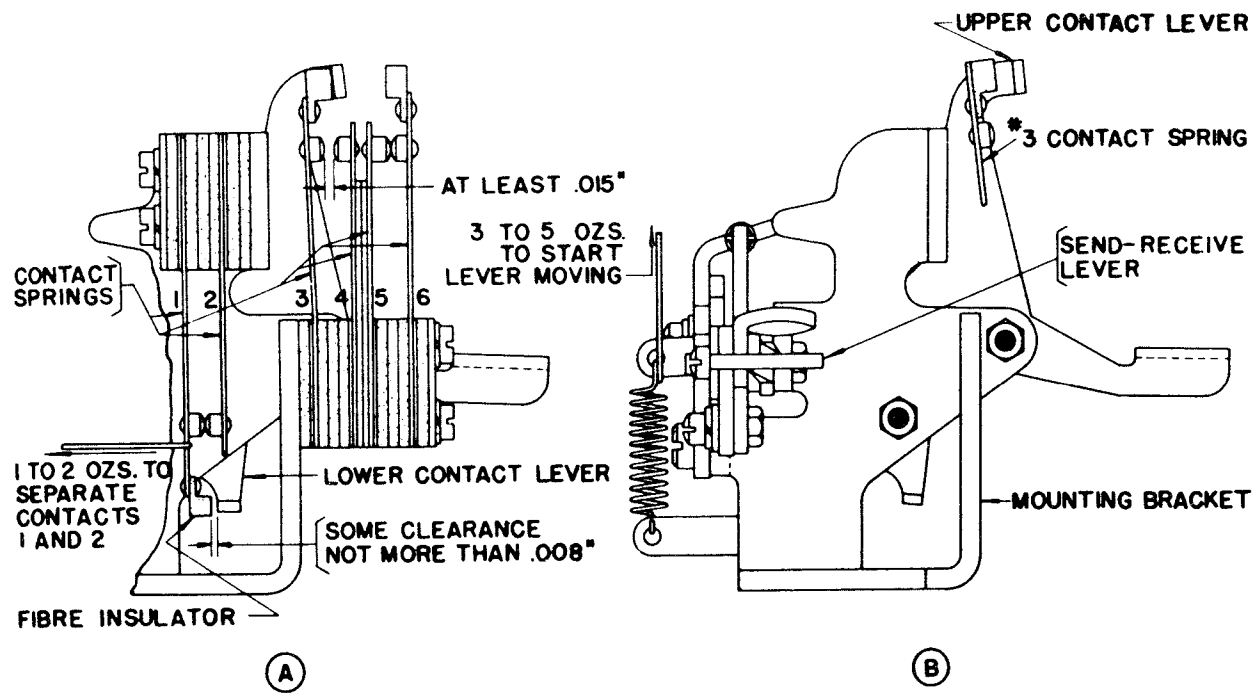

FIGURE 85

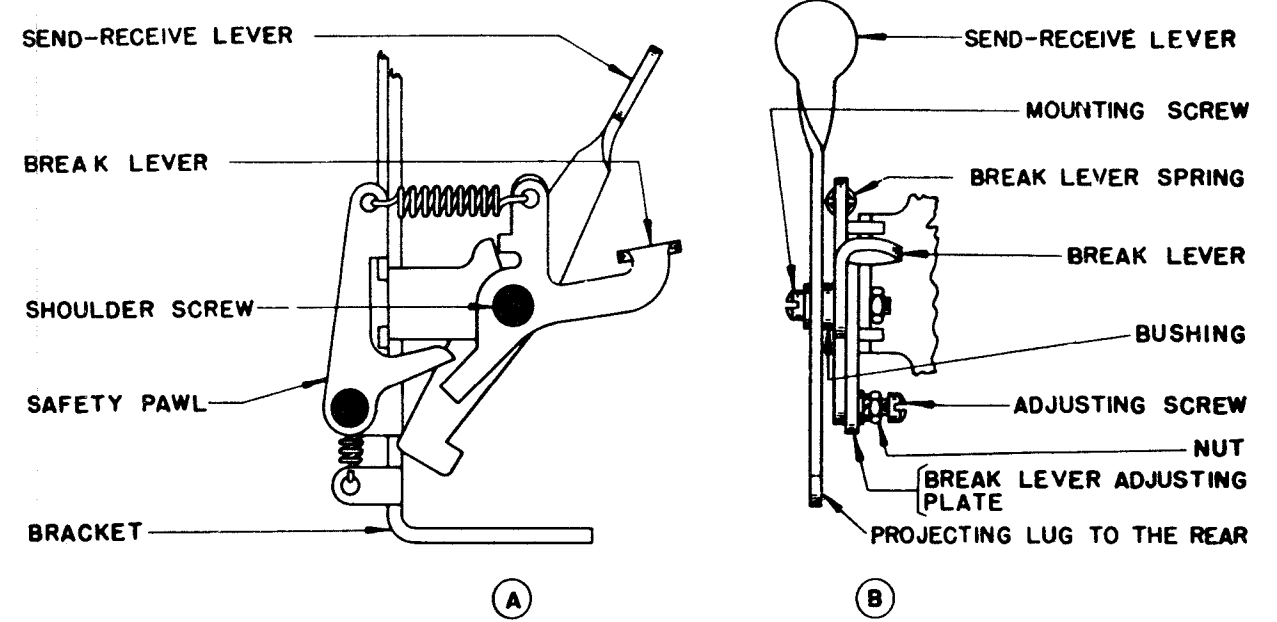

FIGURE 87

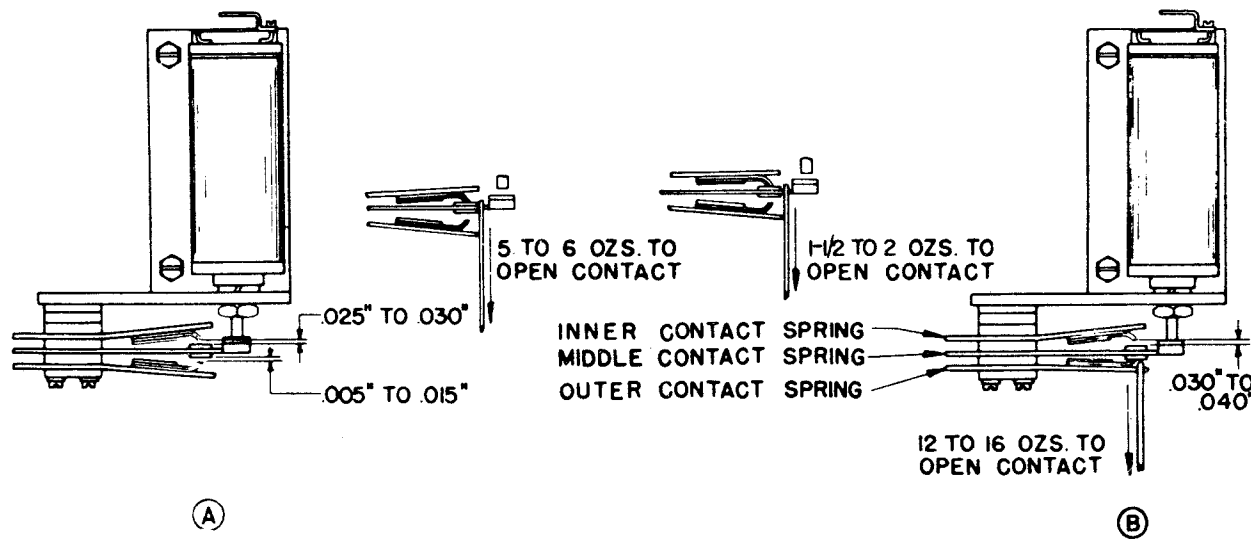

FIGURE 86

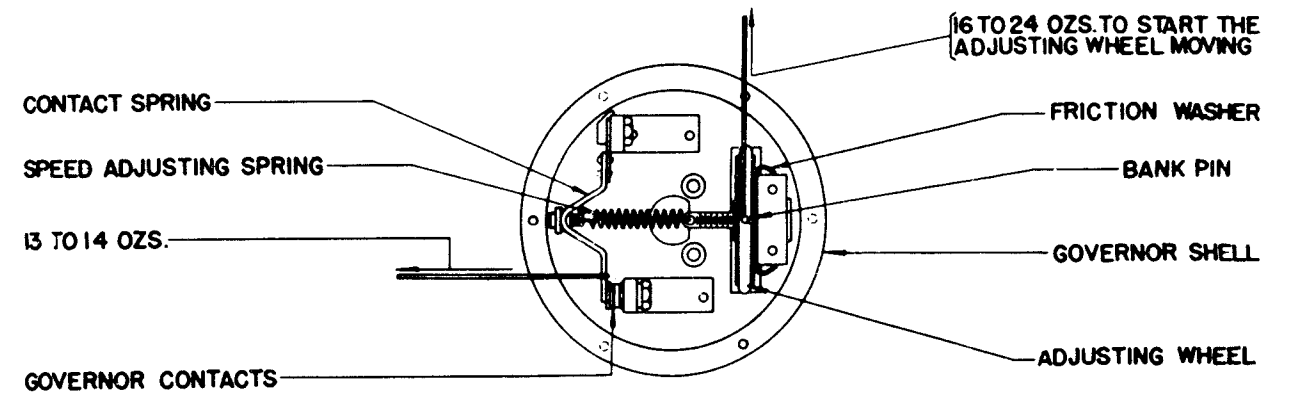

FIGURE 88

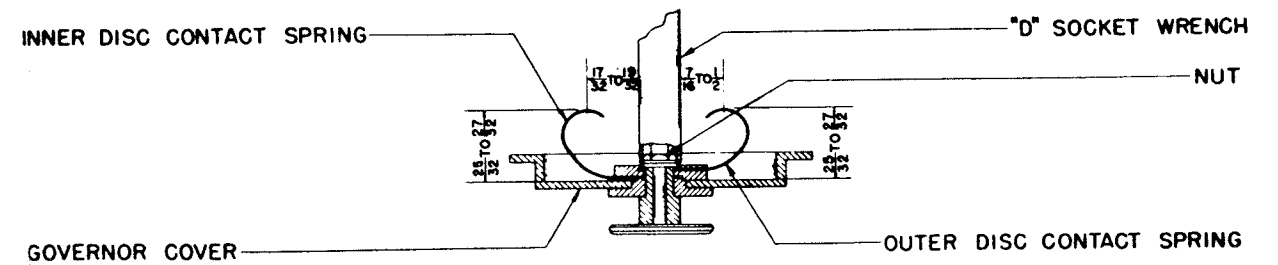

FIGURE 89

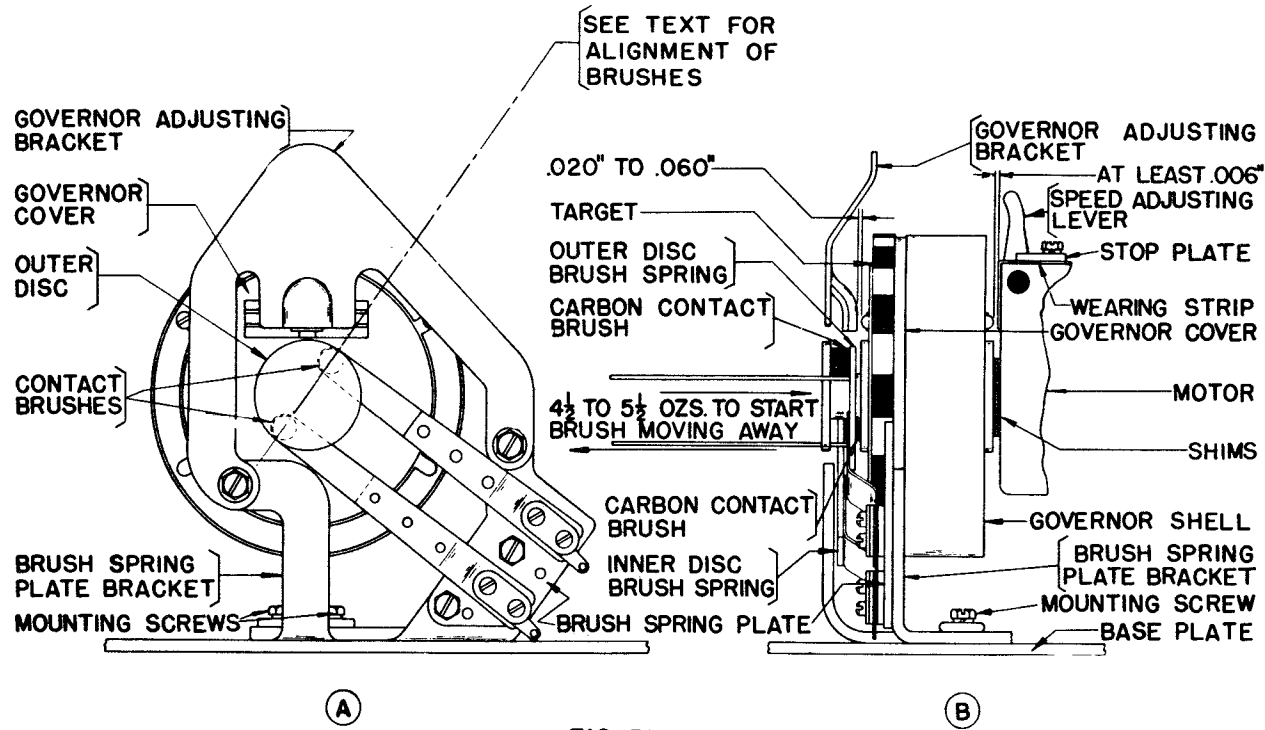

FIGURE 90

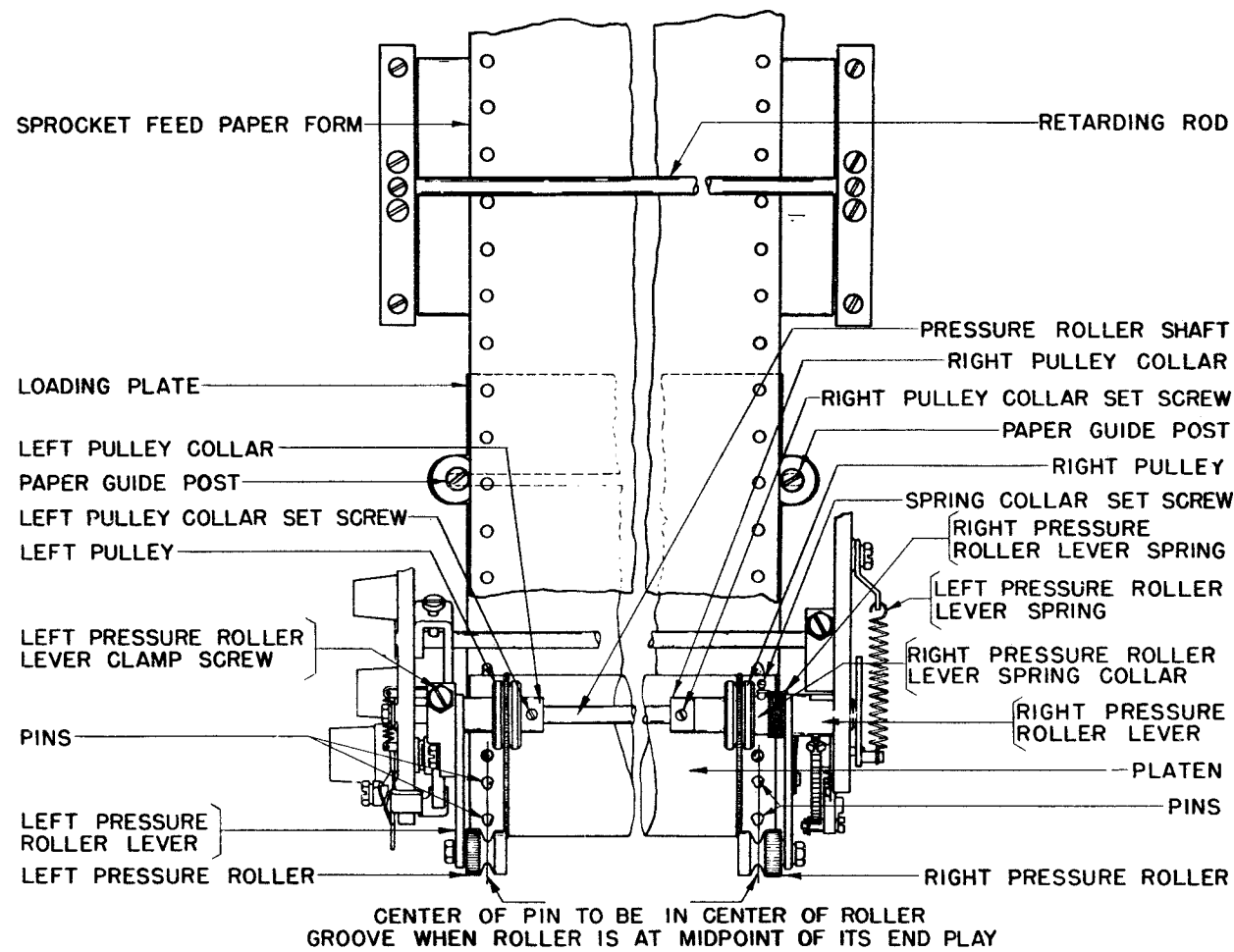

FIGURE 91

ORIGINAL

138B

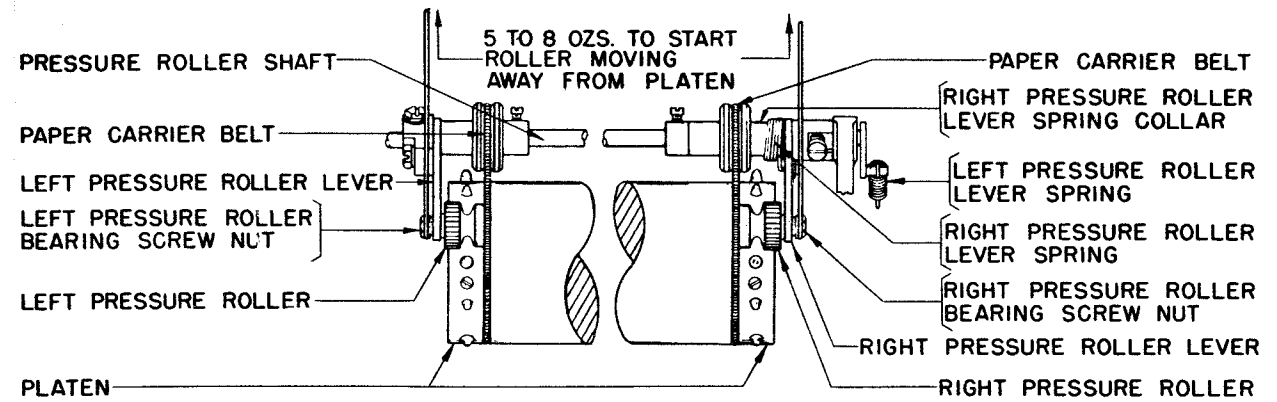

FIGURE 92

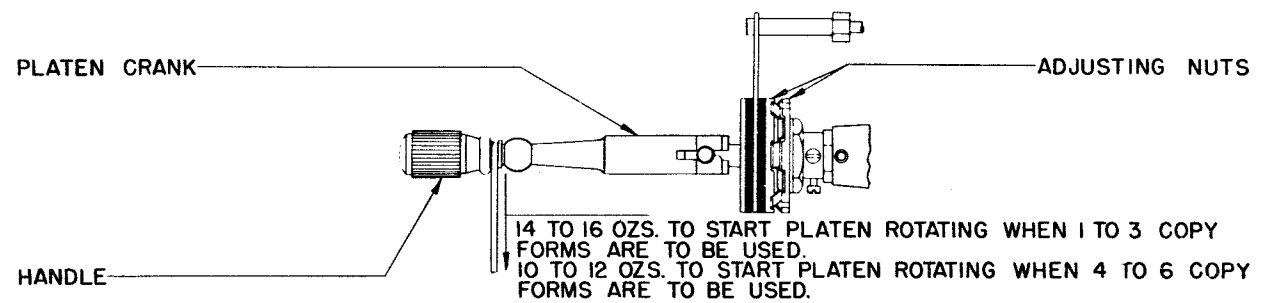

FIGURE 93

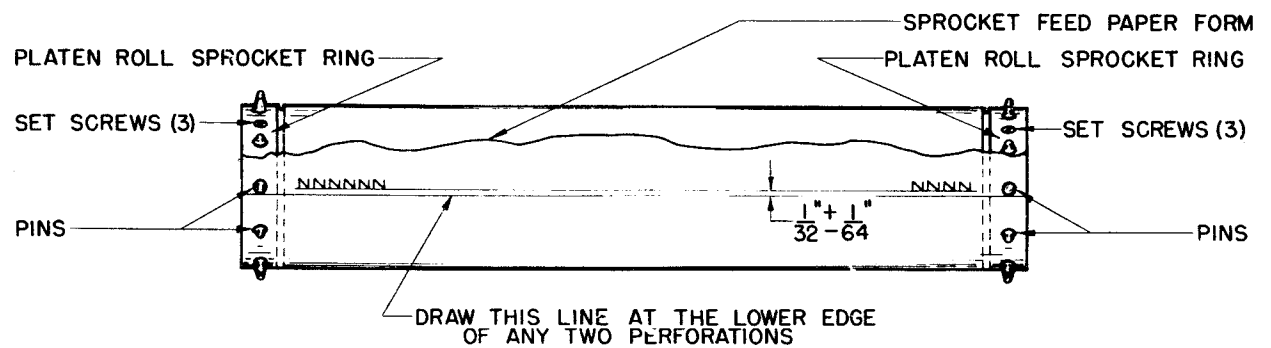

FIGURE 94

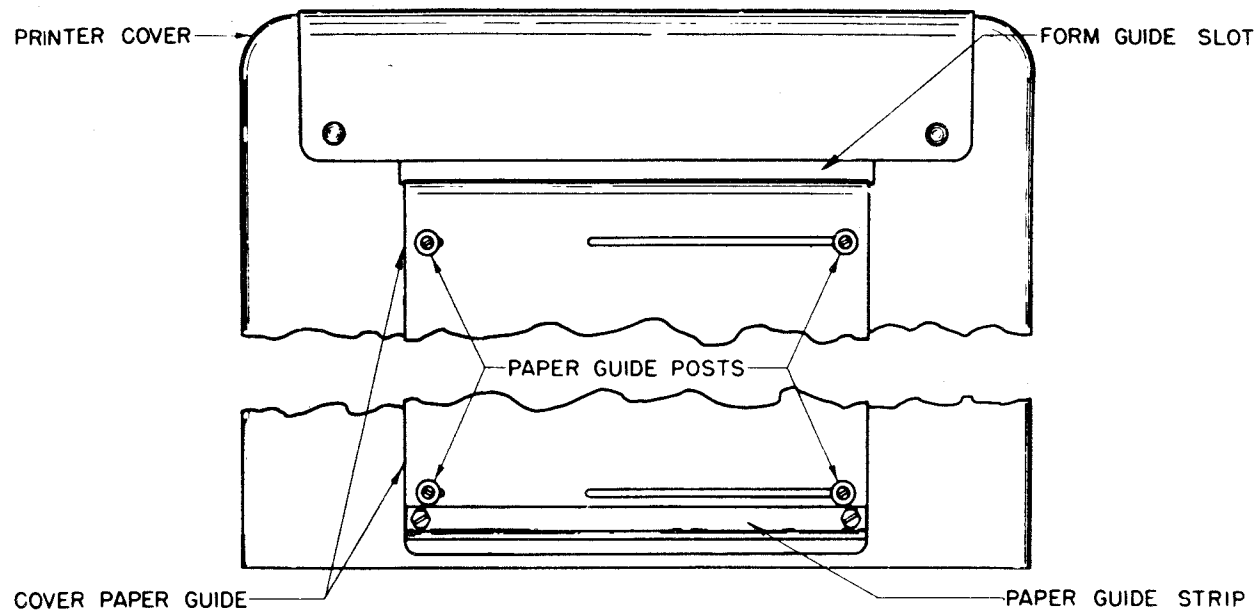

FIGURE 95

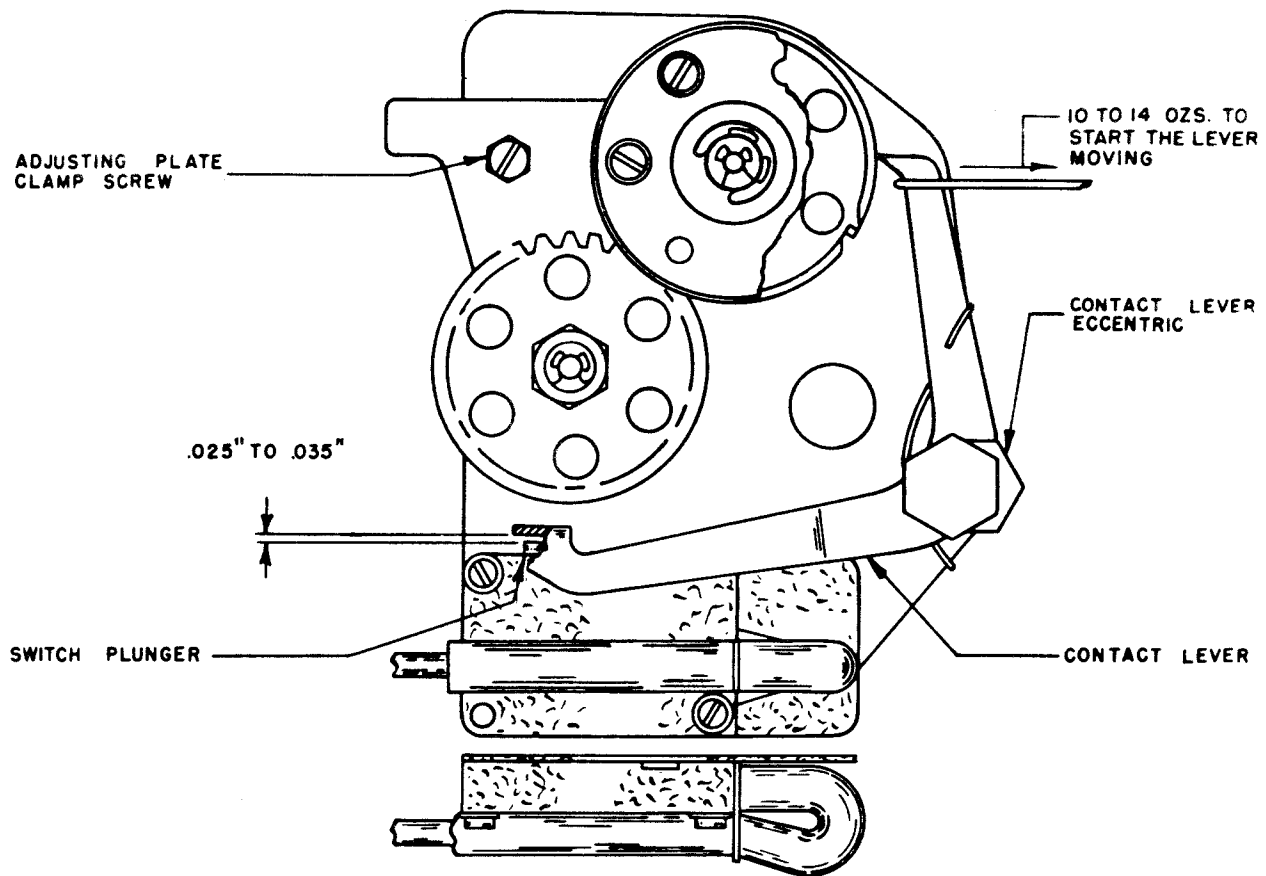

FIGURE 96

138B

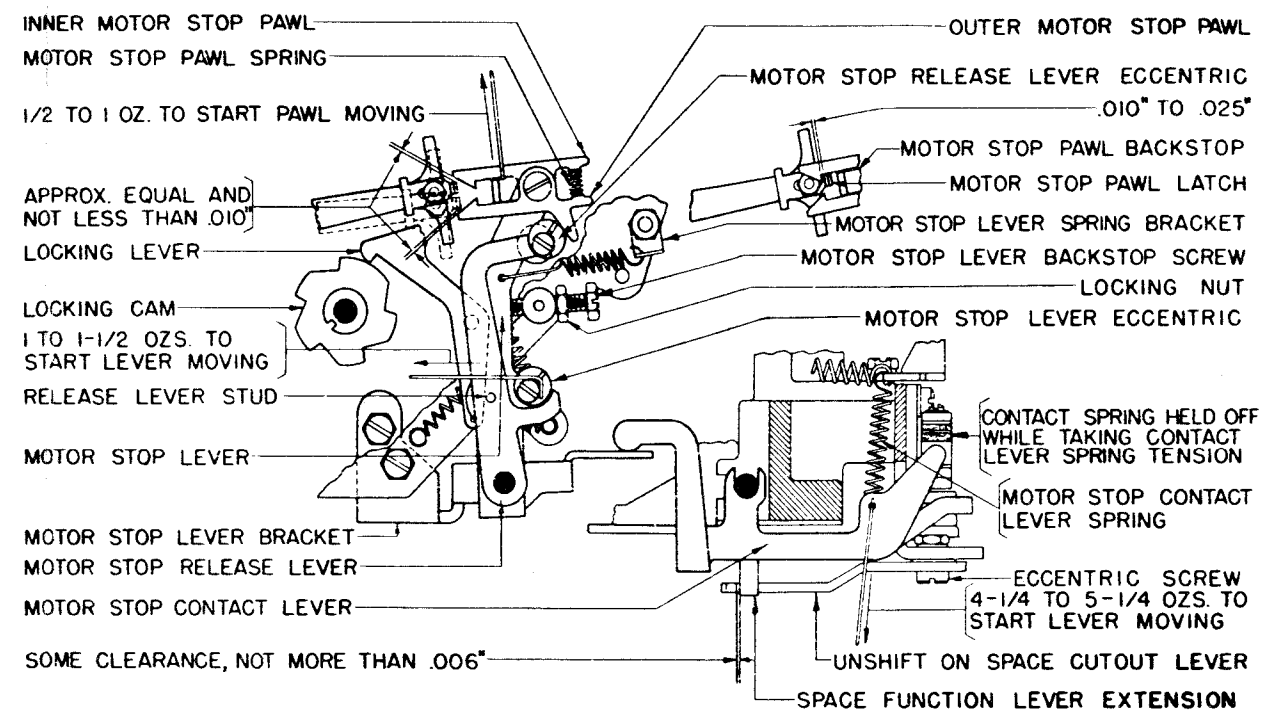

FIGURE 97

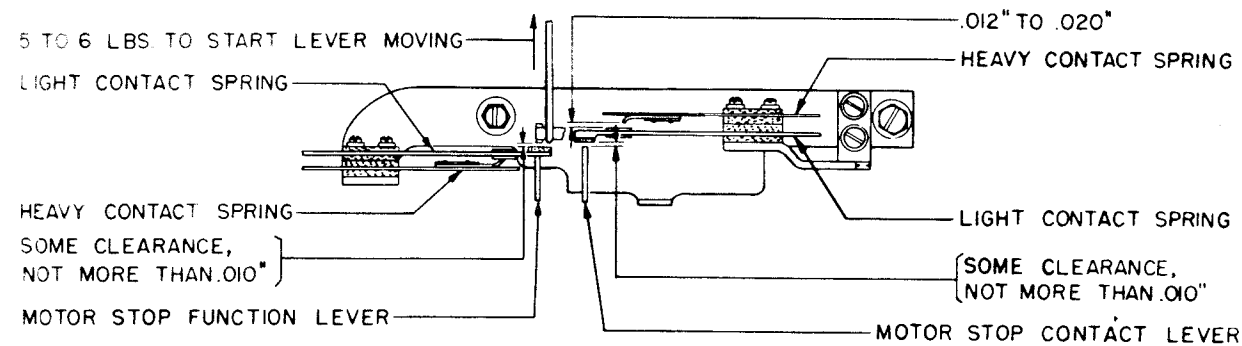

FIGURE 98

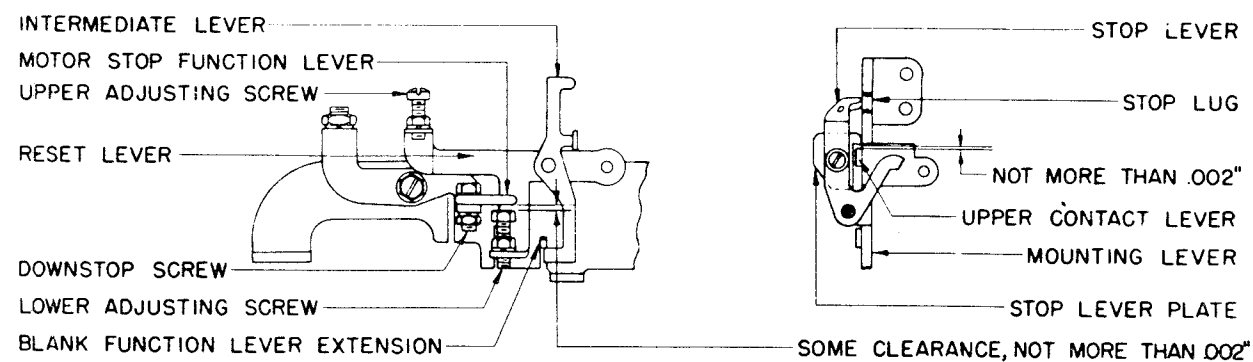

FIGURE 99

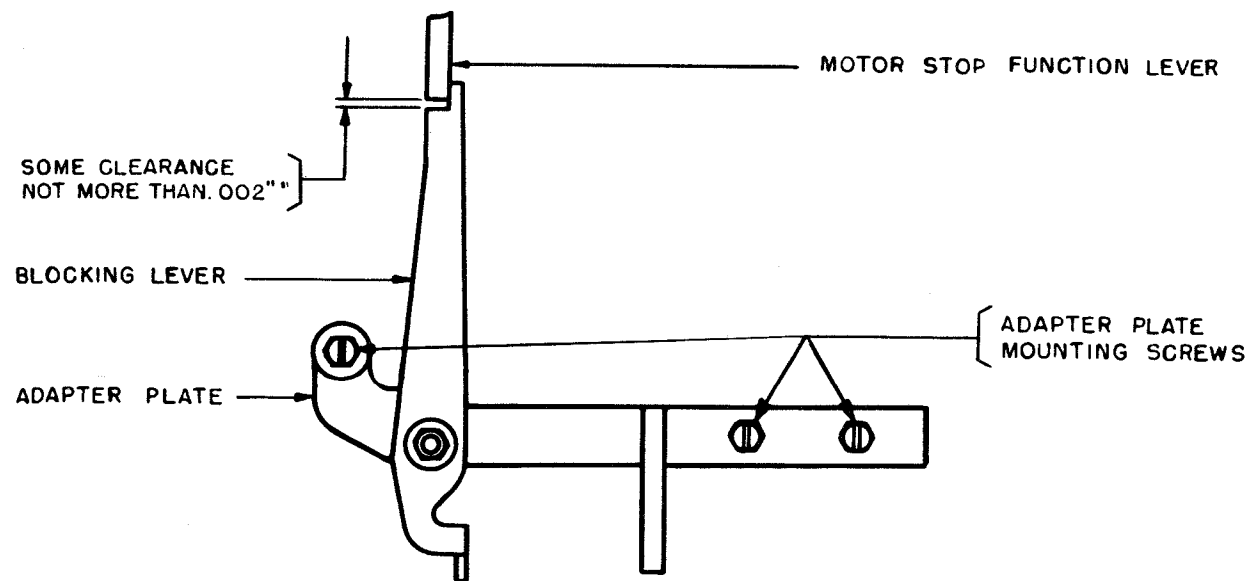

FIGURE 100

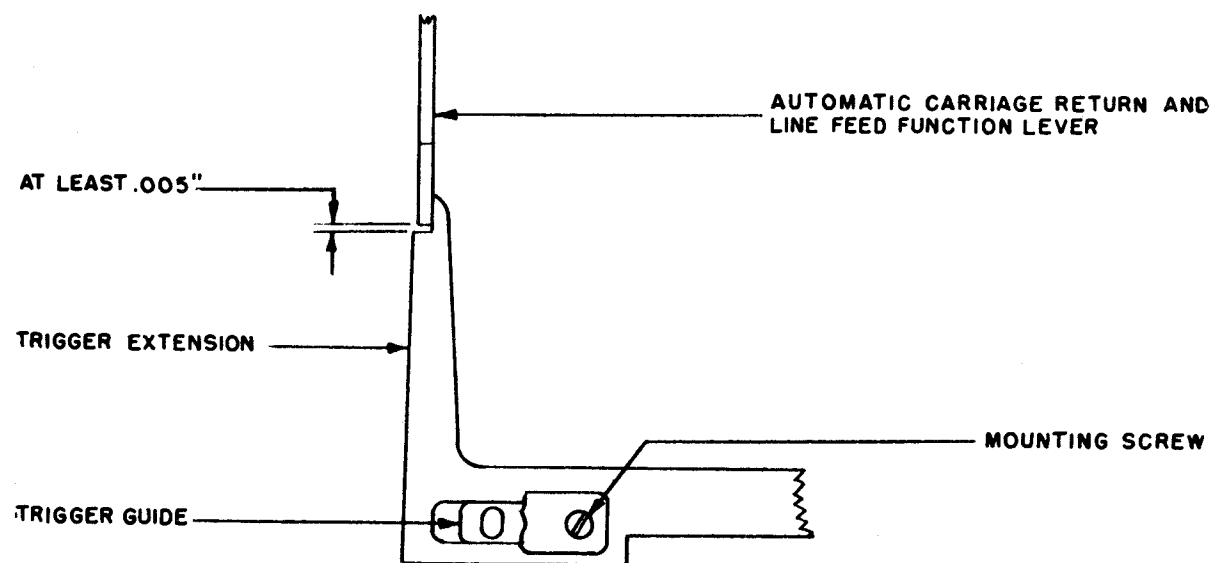

FIGURE 101

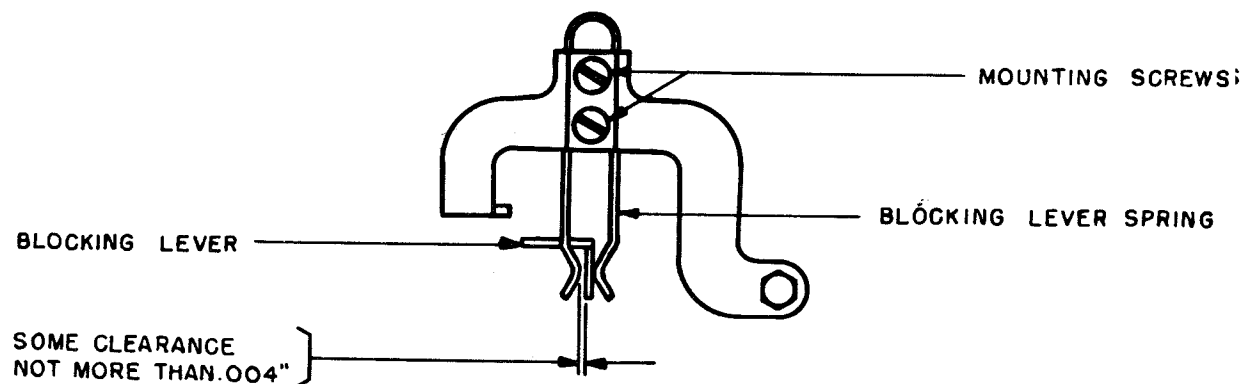

FIGURE 102

ORIGINAL

138B

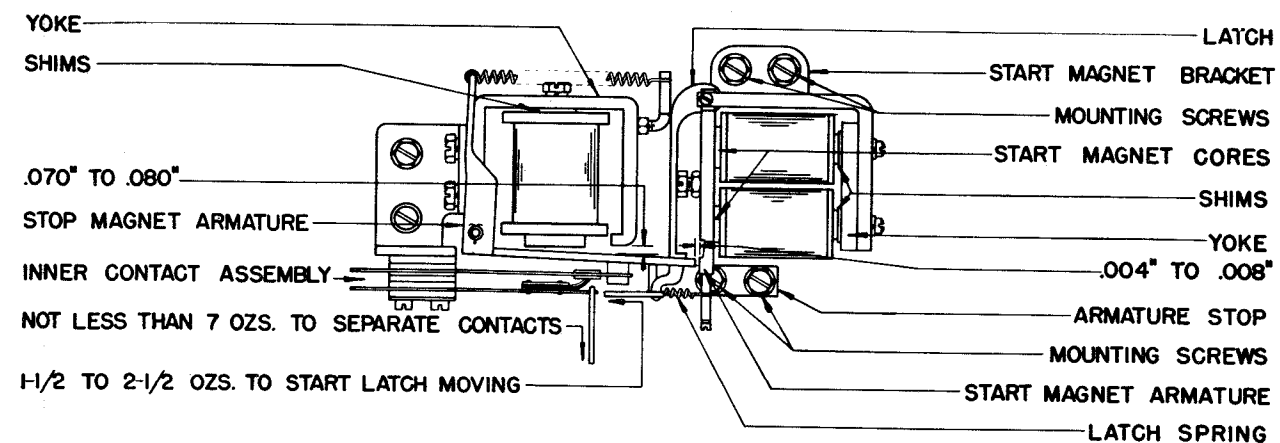

FIGURE 103

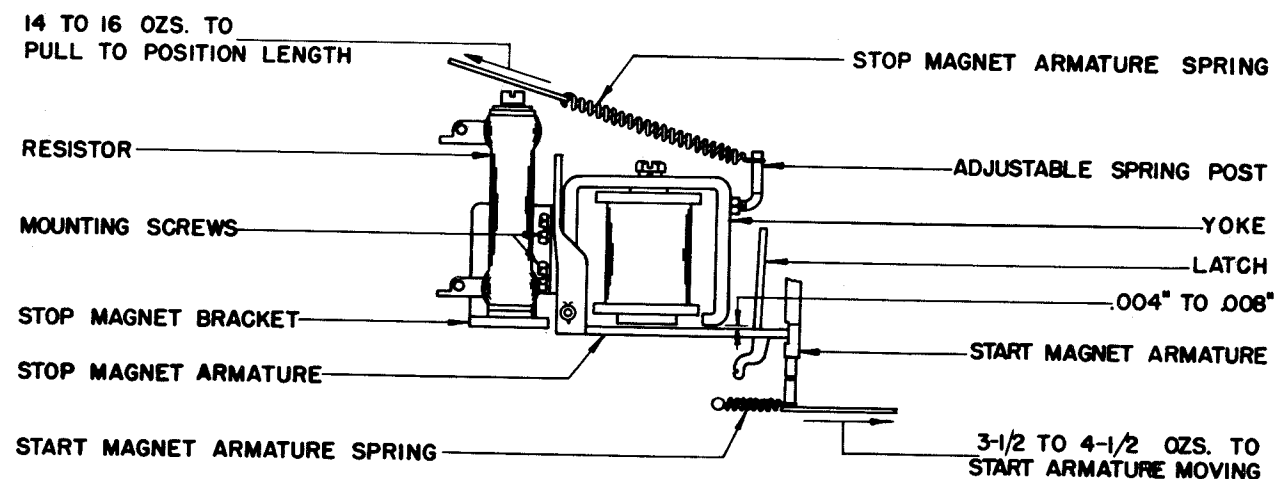

FIGURE 104

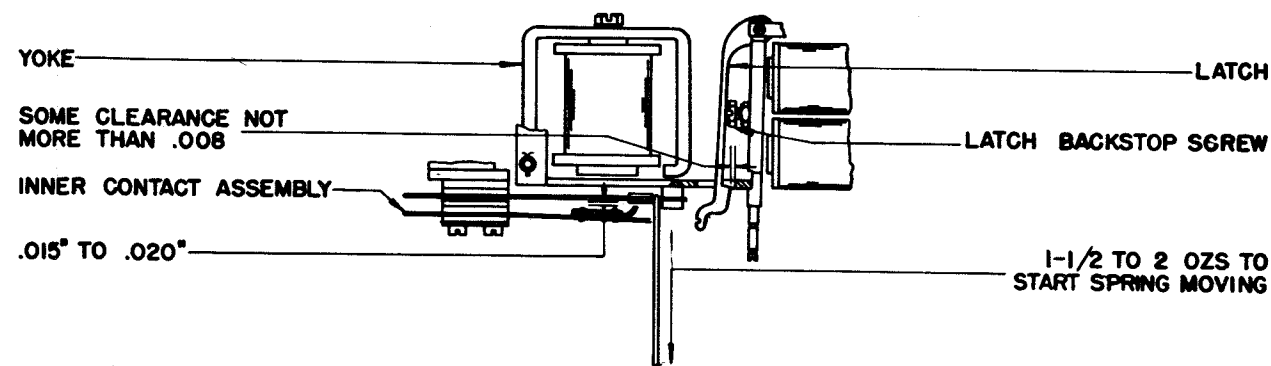

FIGURE 105

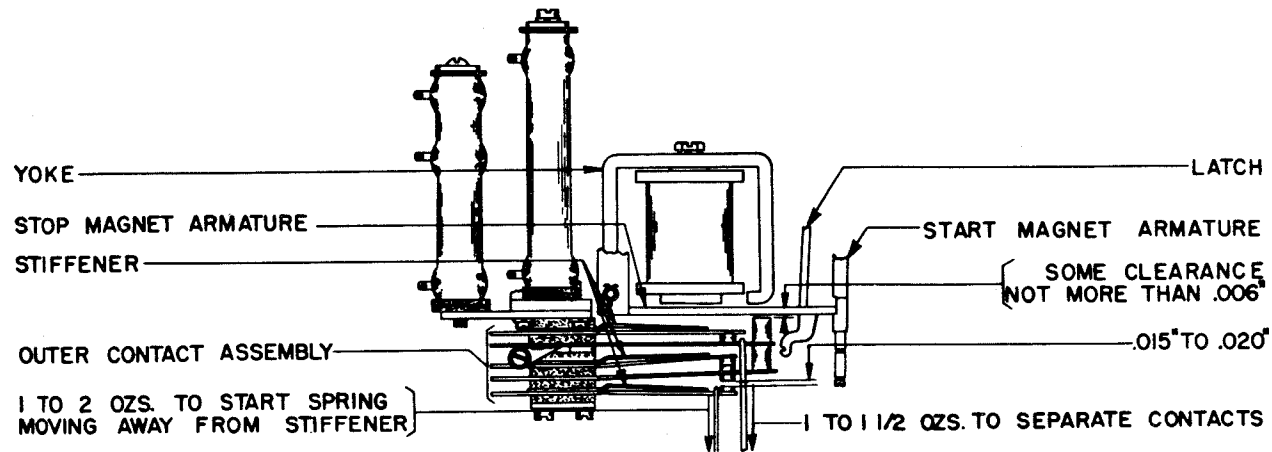

FIGURE 106

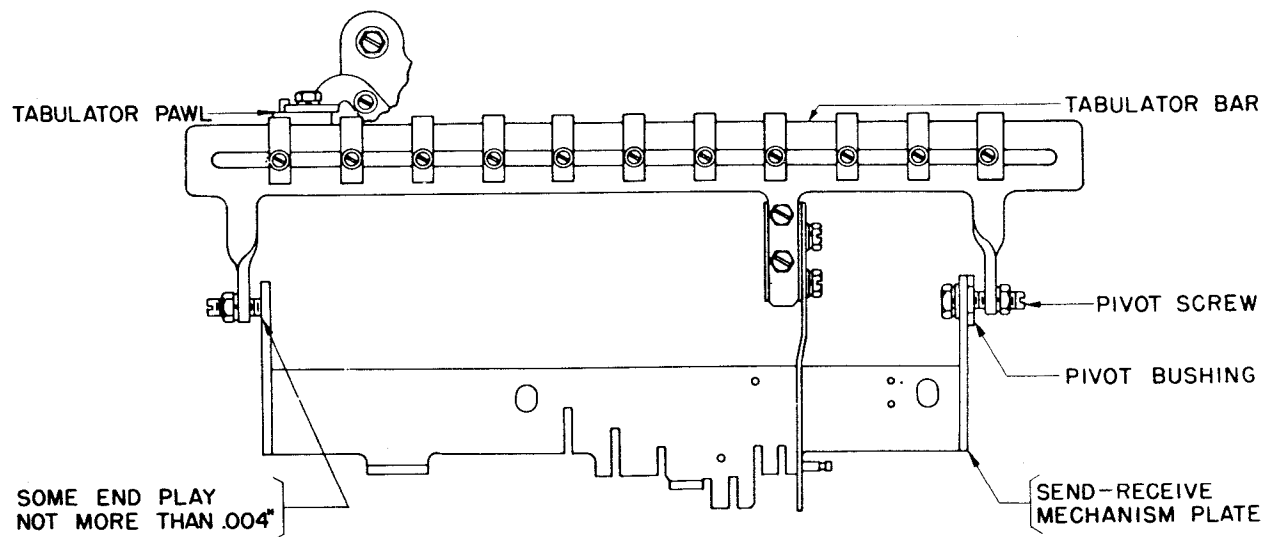

FIGURE 107

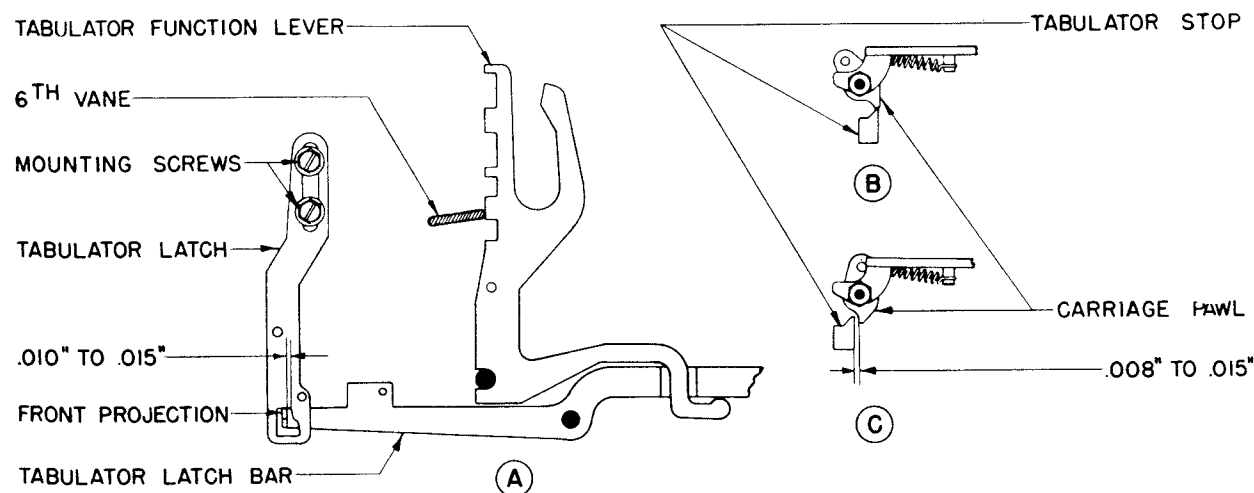

FIGURE 108

ORIGINAL

138B

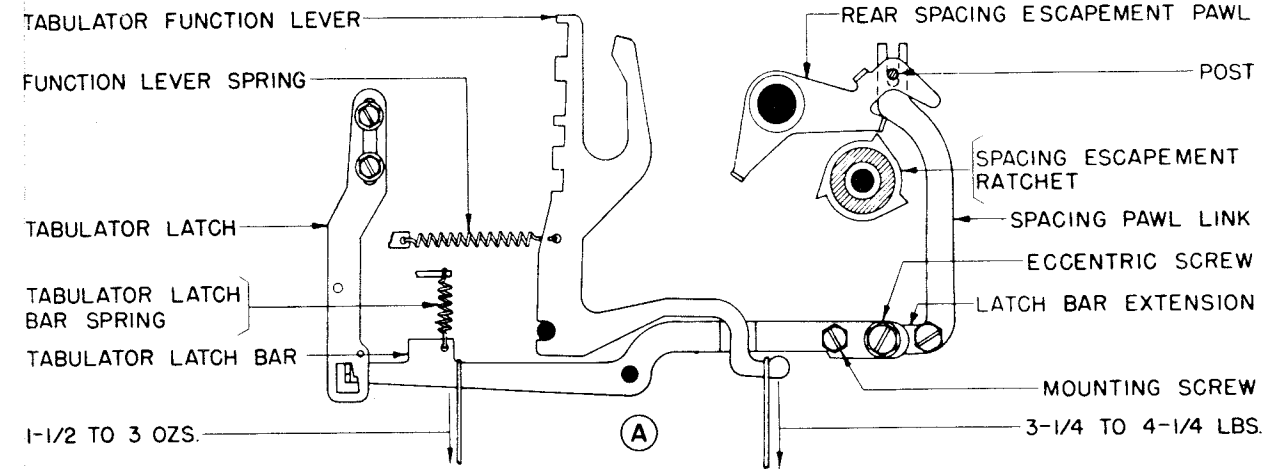
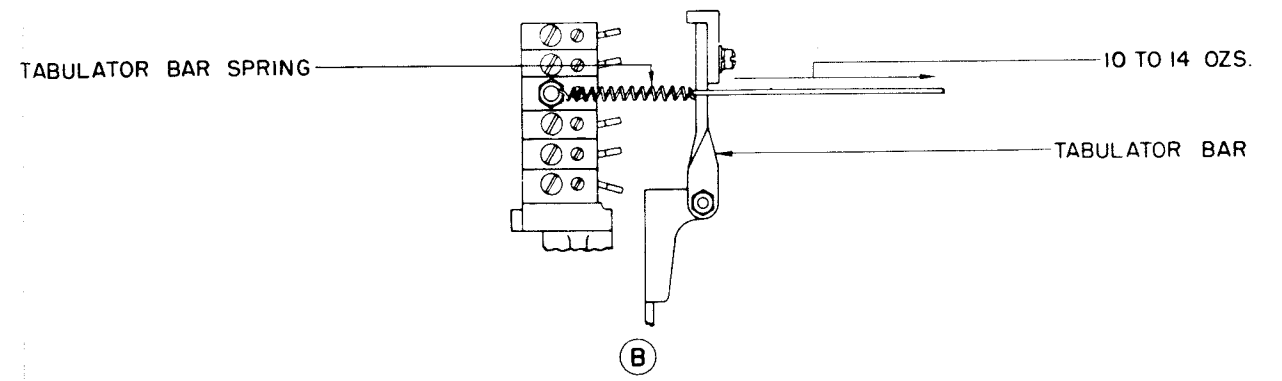

FIGURE 109

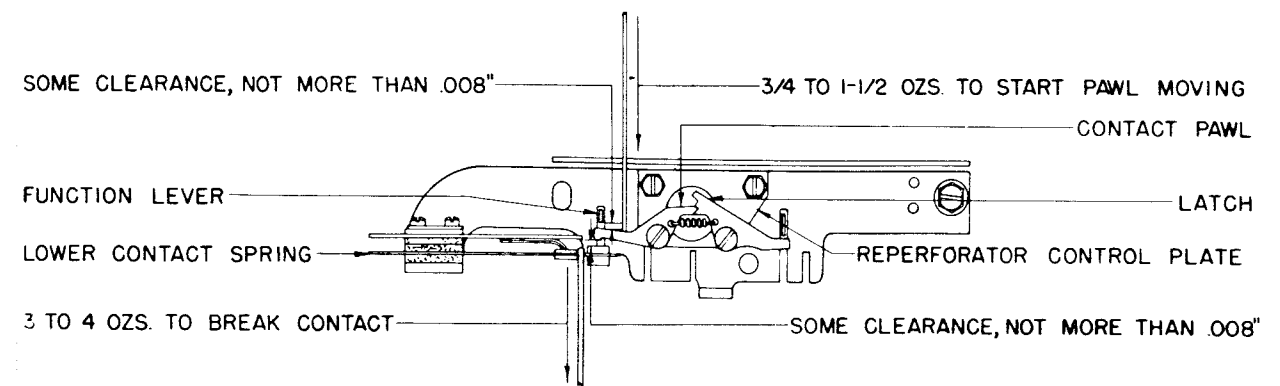

FIGURE 110

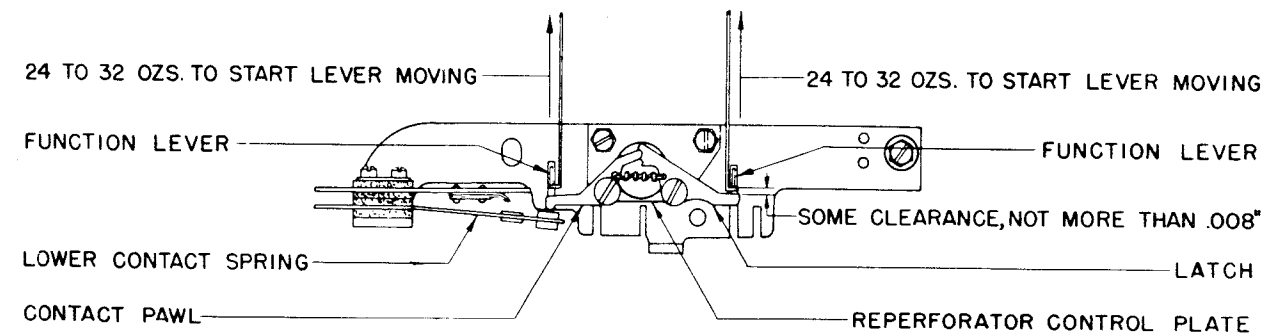

FIGURE 111

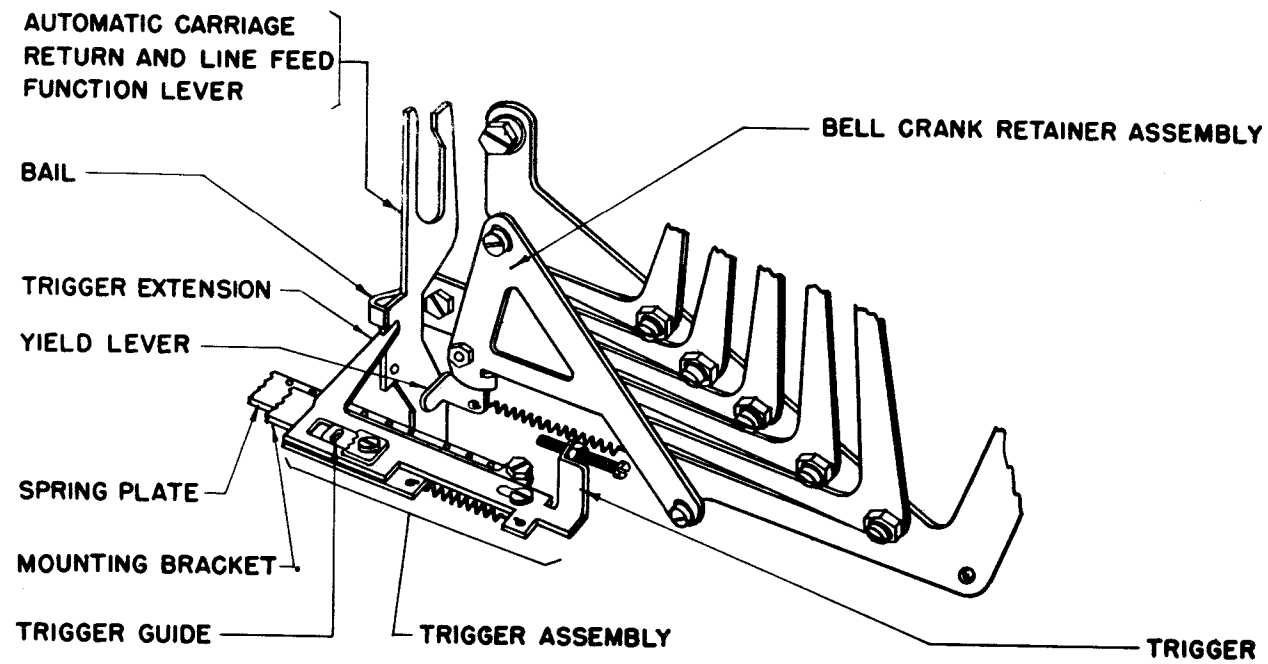

FIGURE 112

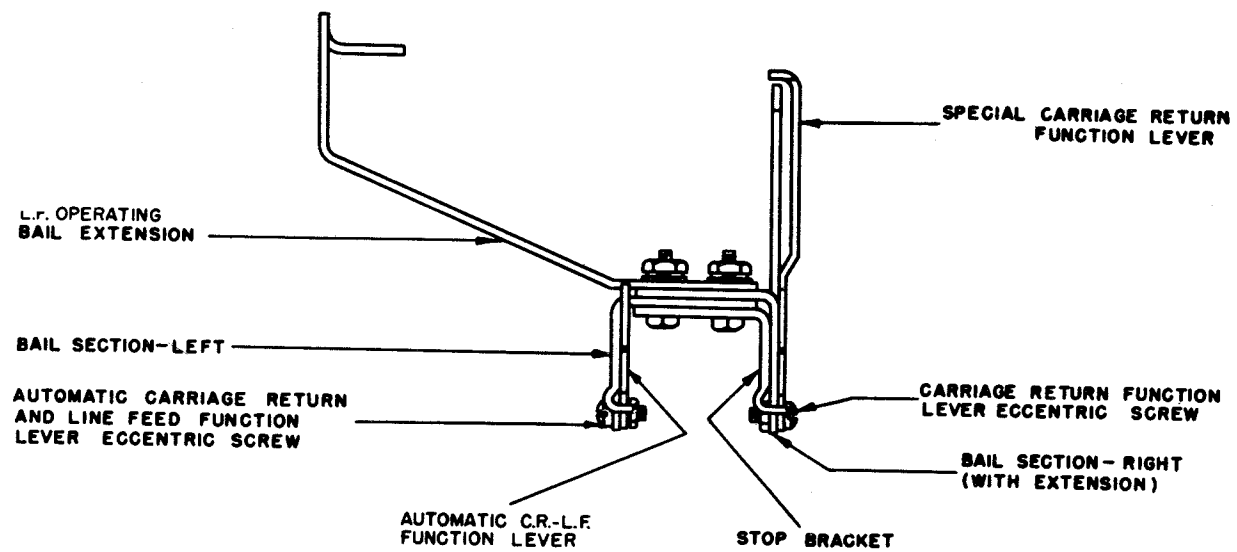

FIGURE 113

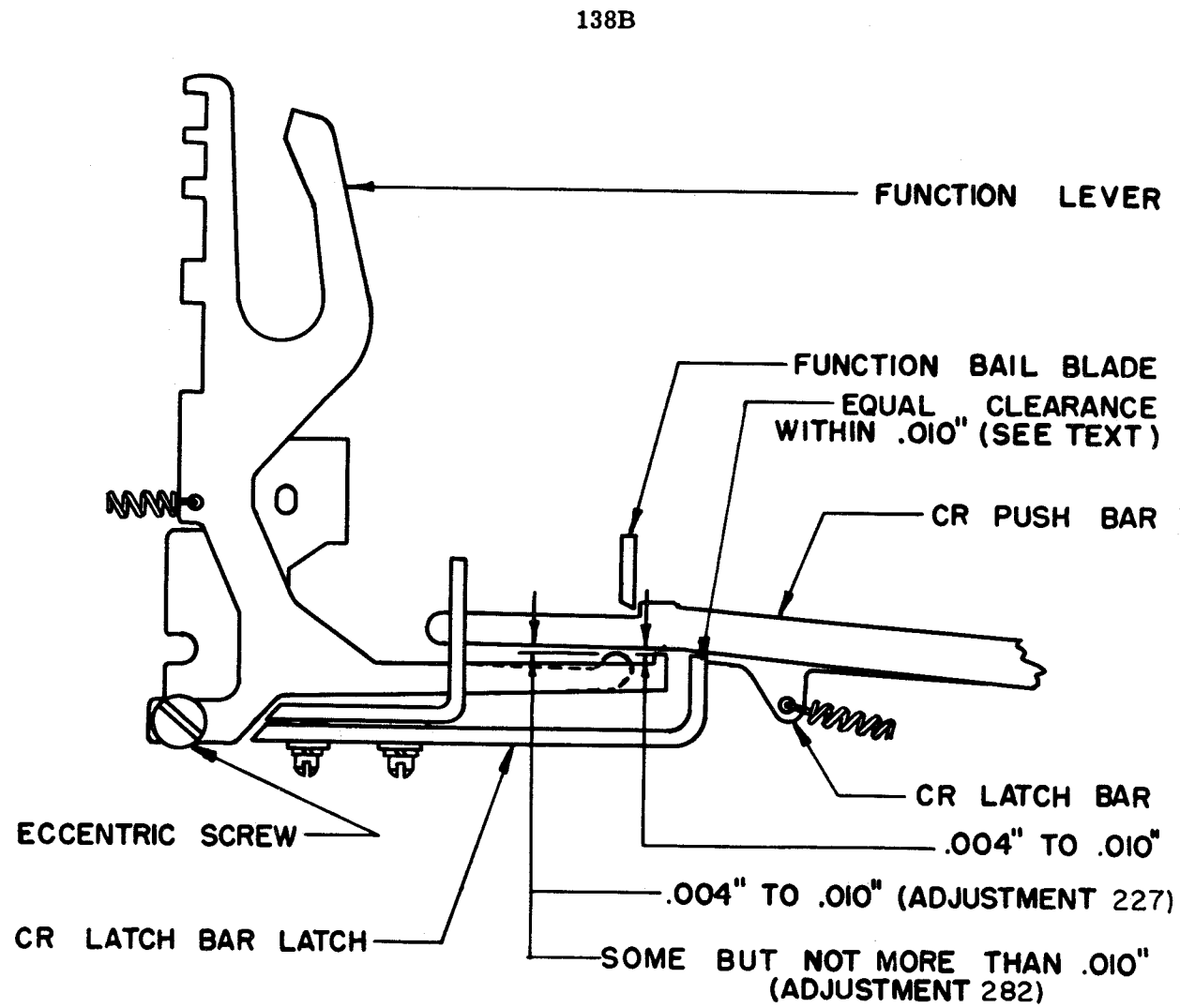

FIGURE 114

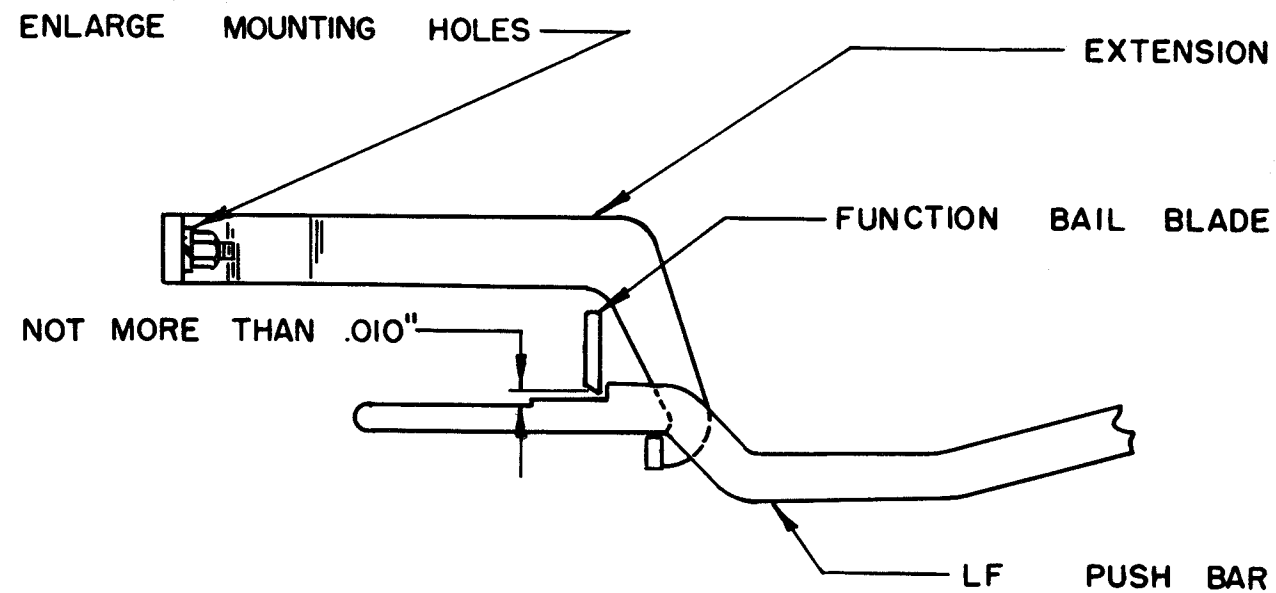

FIGURE 115

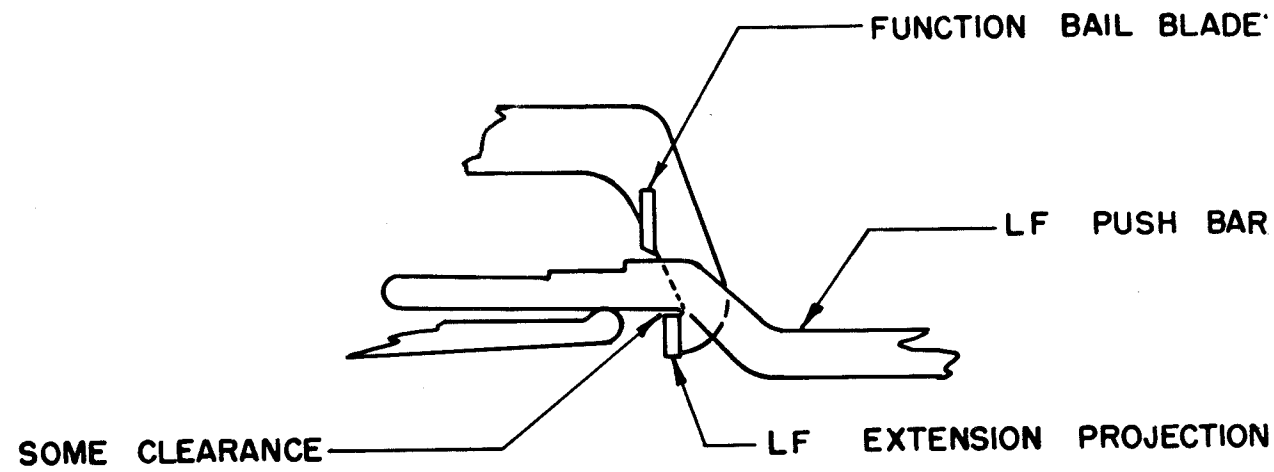

FIGURE 116

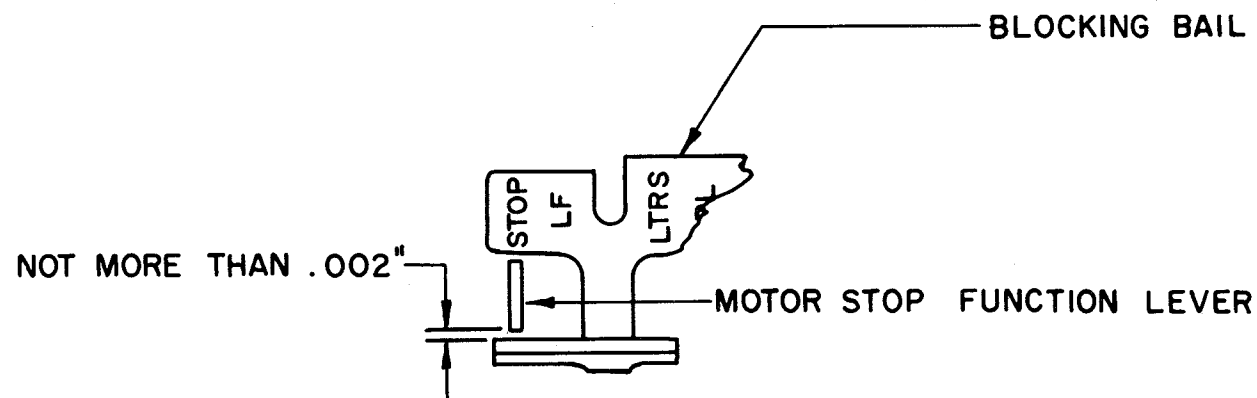

FIGURE 117

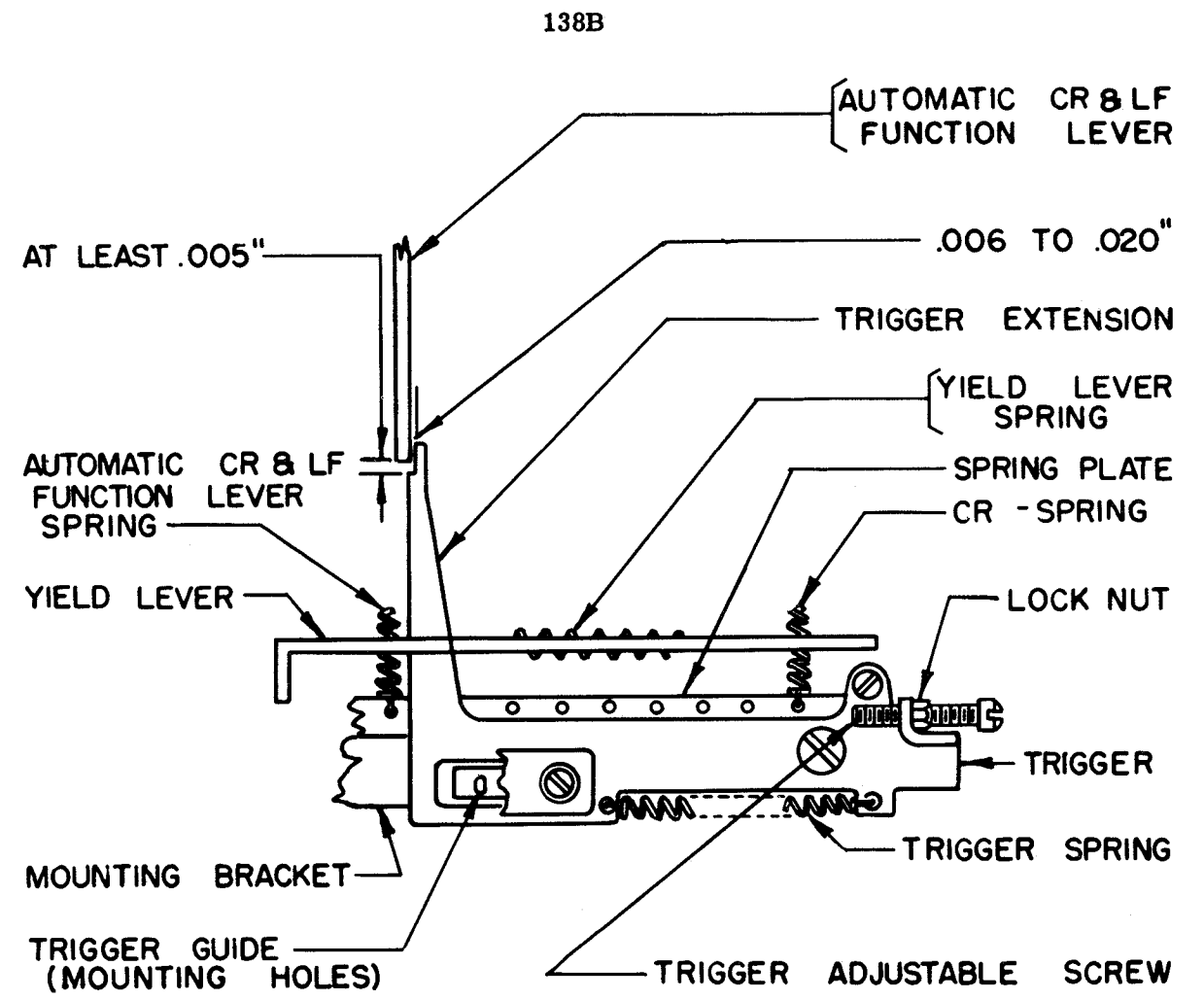

FIGURE 118

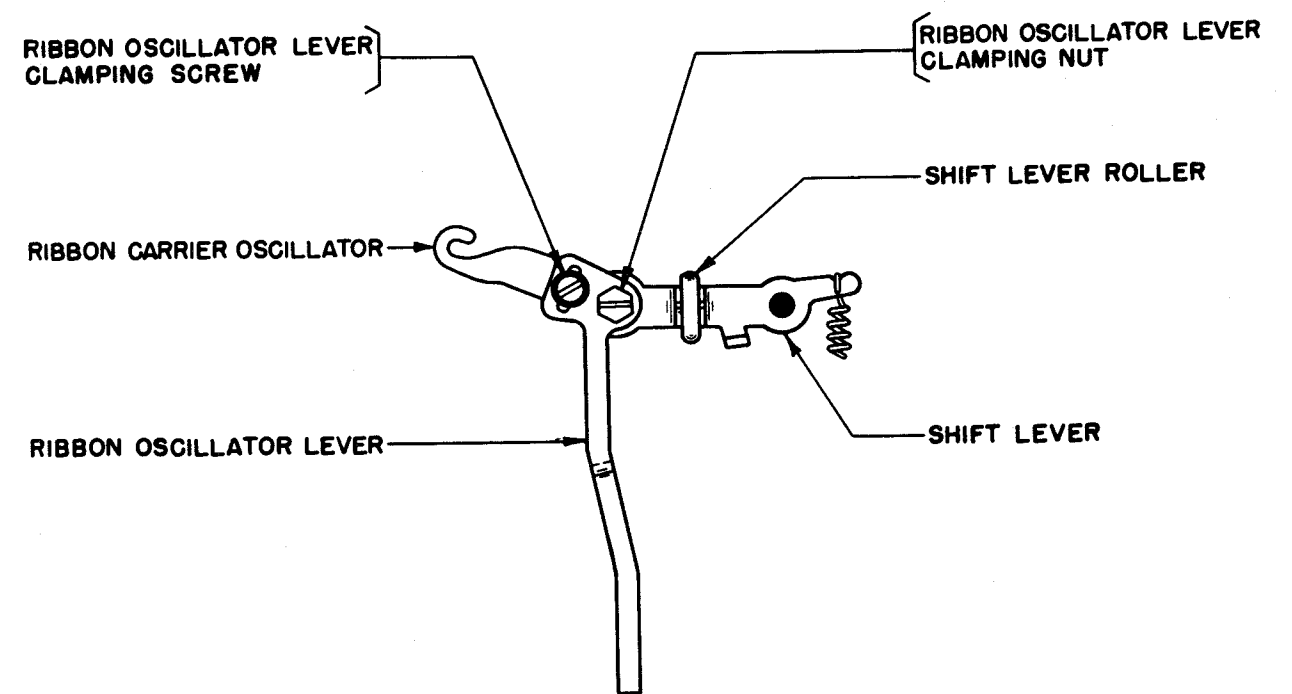

FIGURE 119

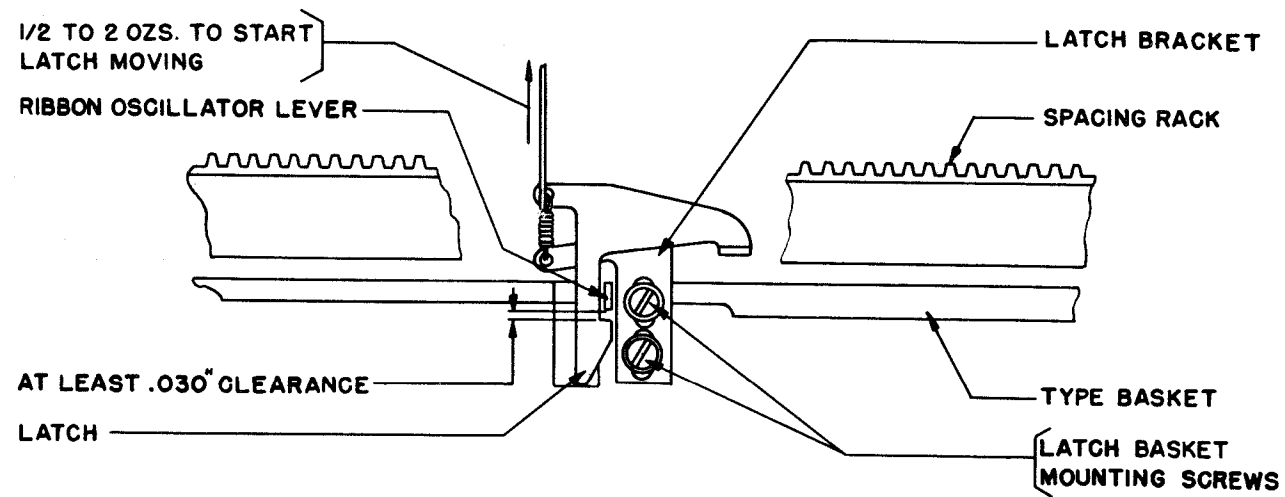

FIGURE 120

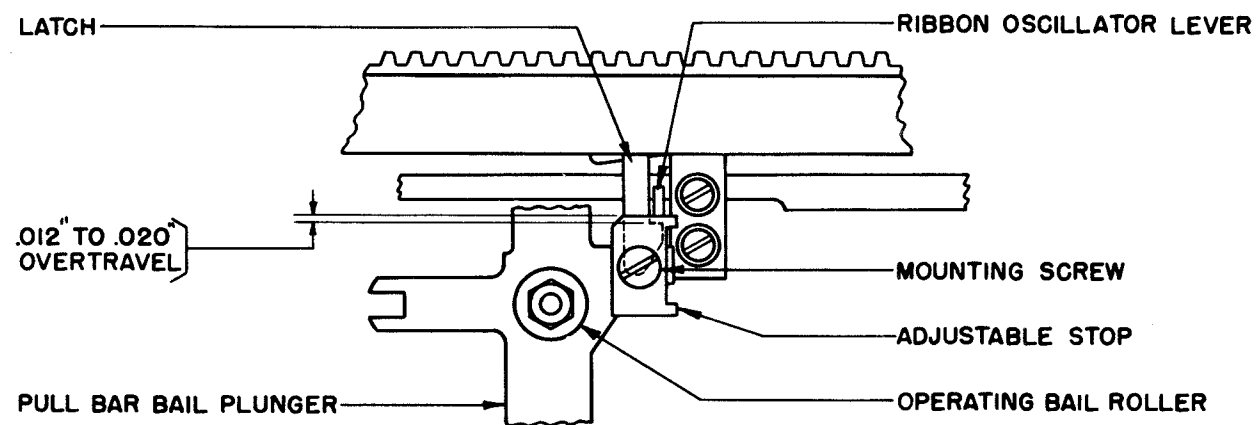

FIGURE 121

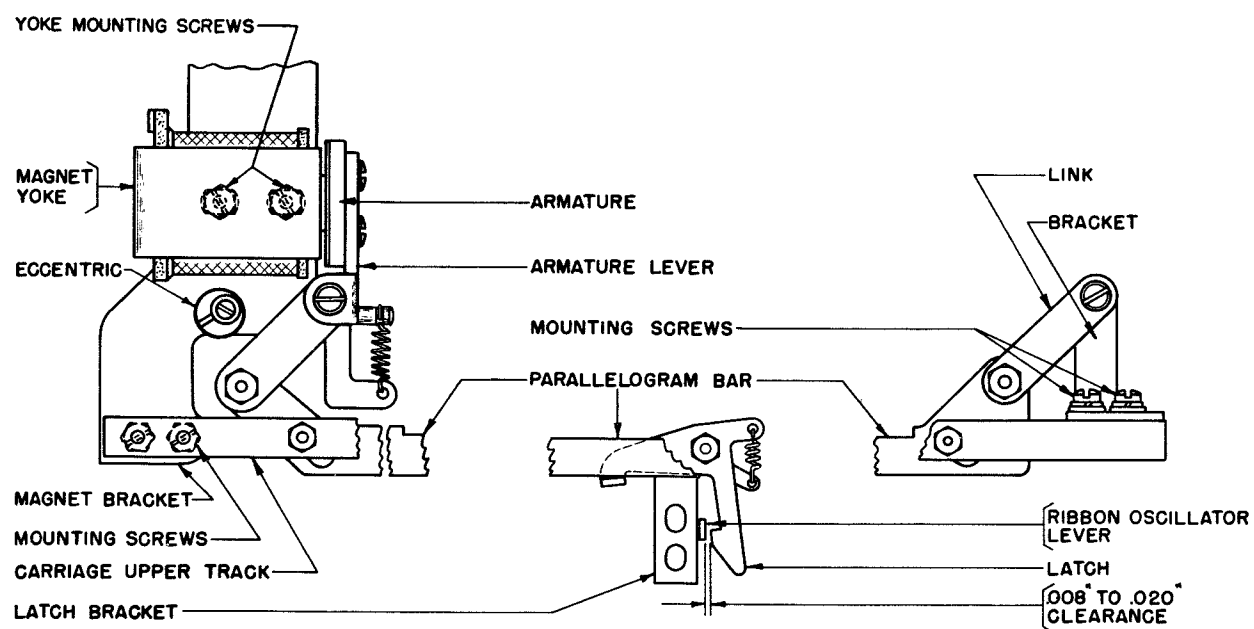

FIGURE 122

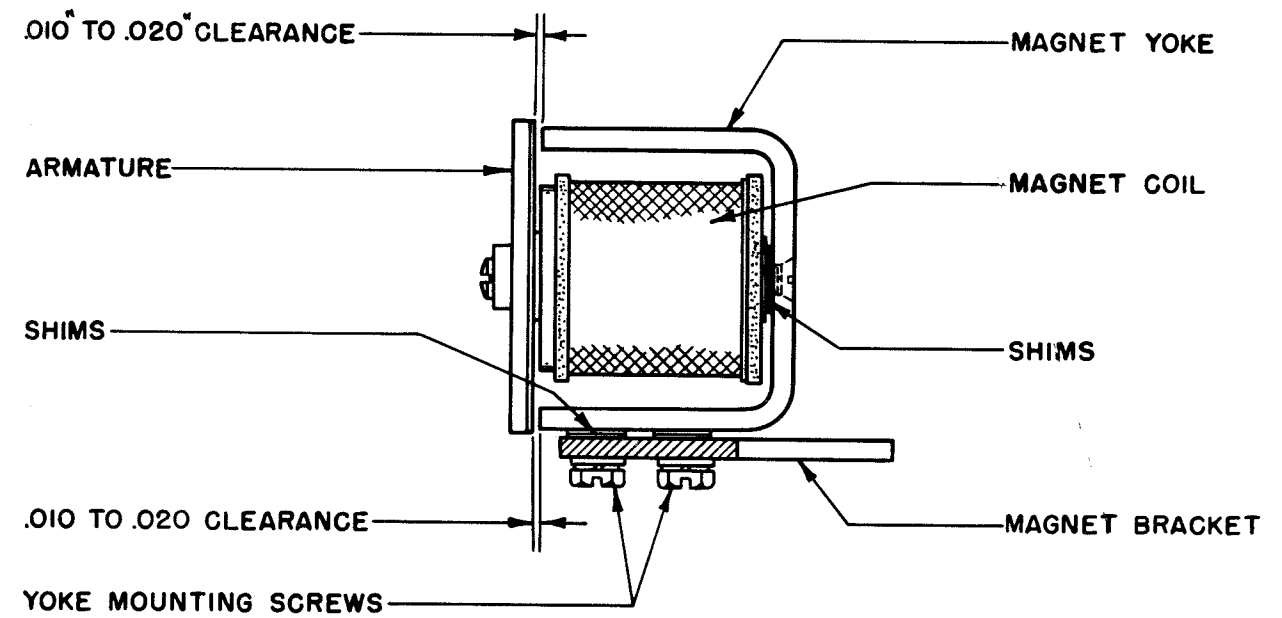

FIGURE 123

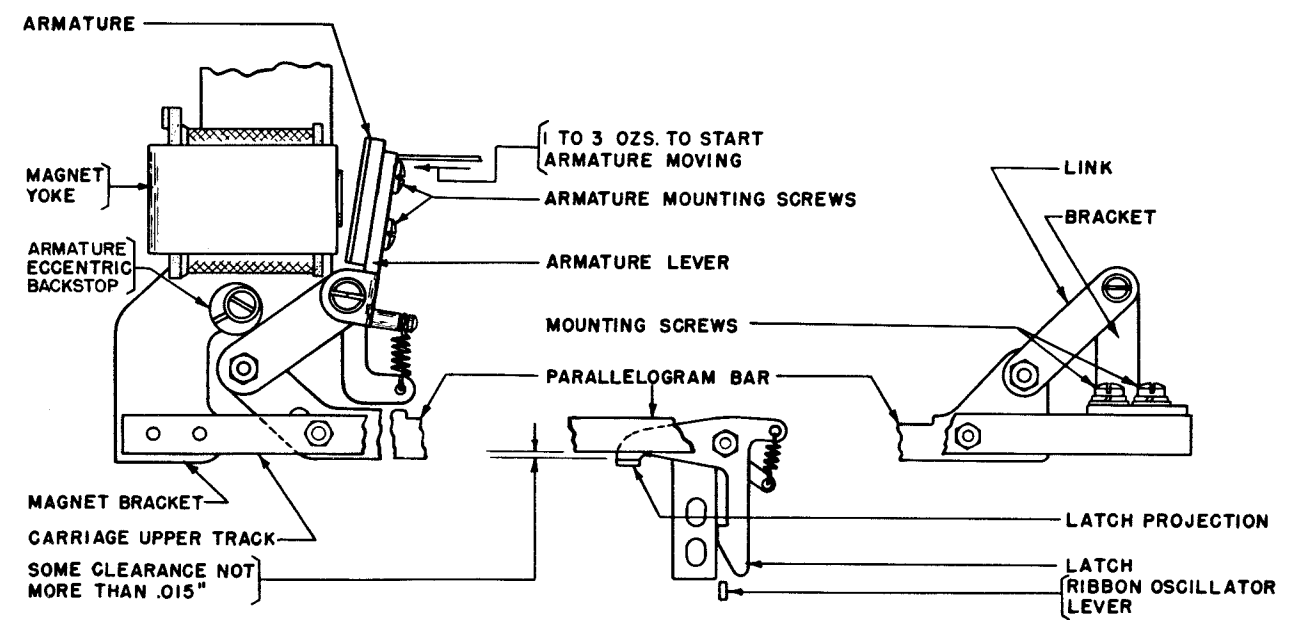

FIGURE 124

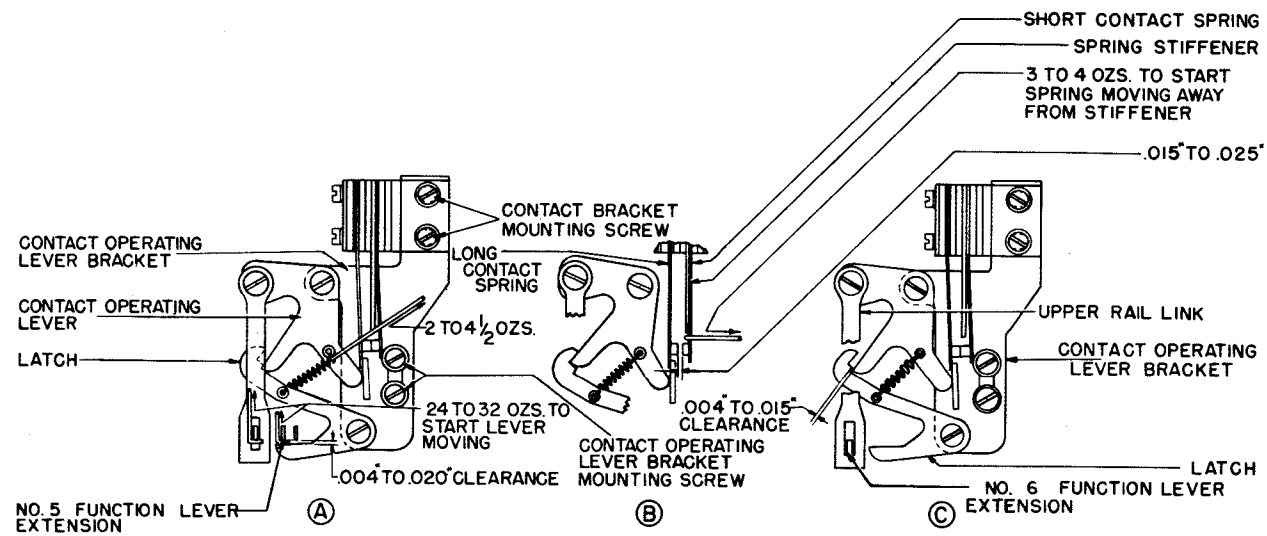

FIGURE 125

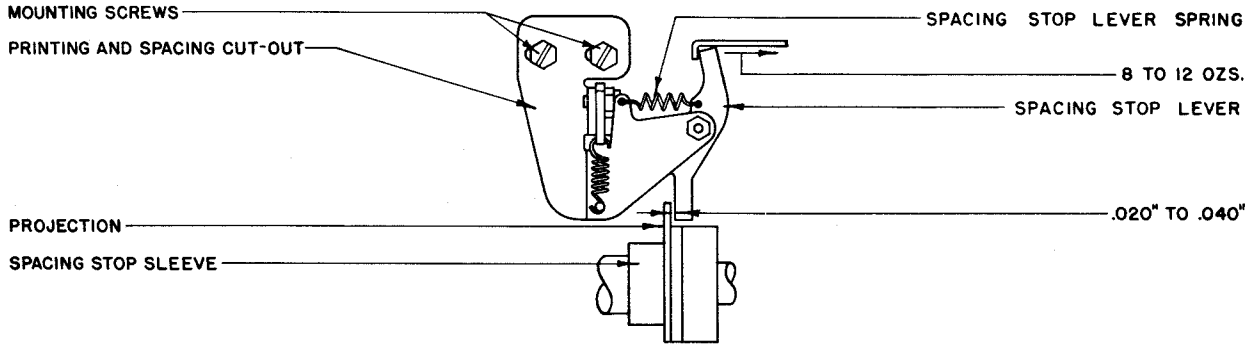

FIGURE 126

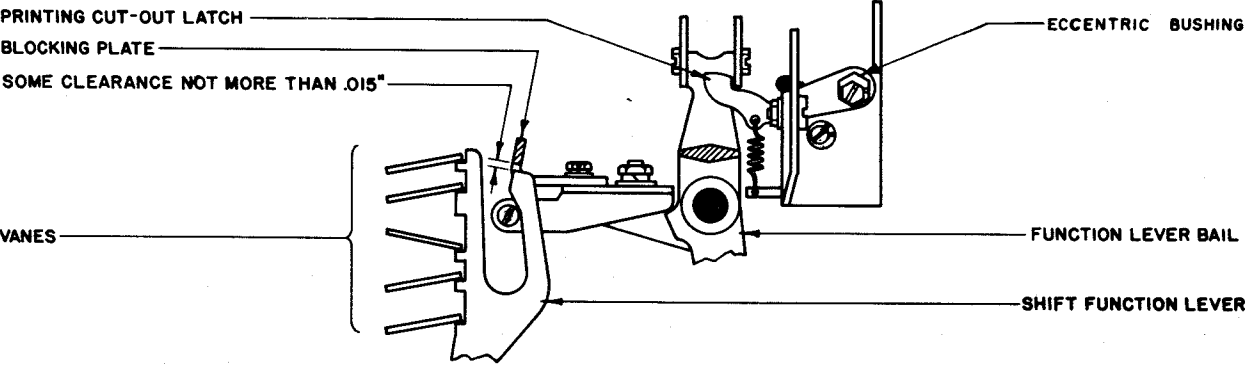

FIGURE 127

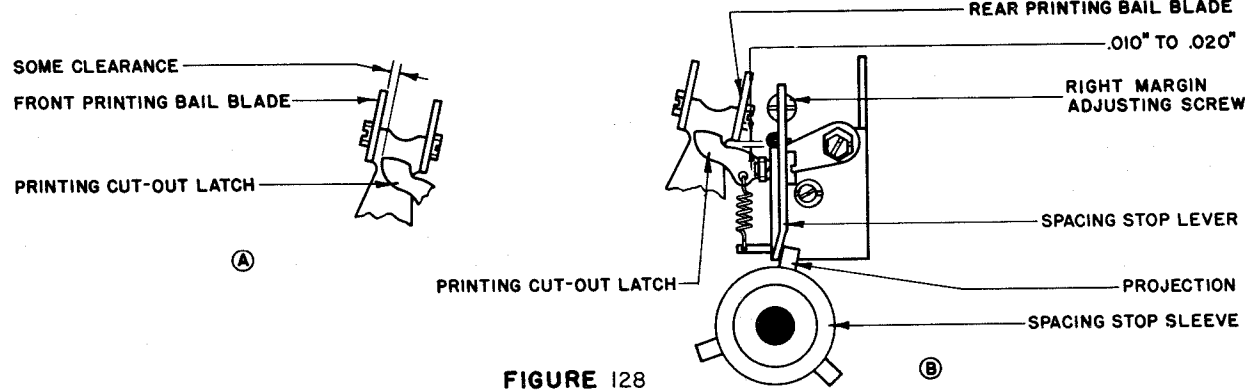

FIGURE 128

138B

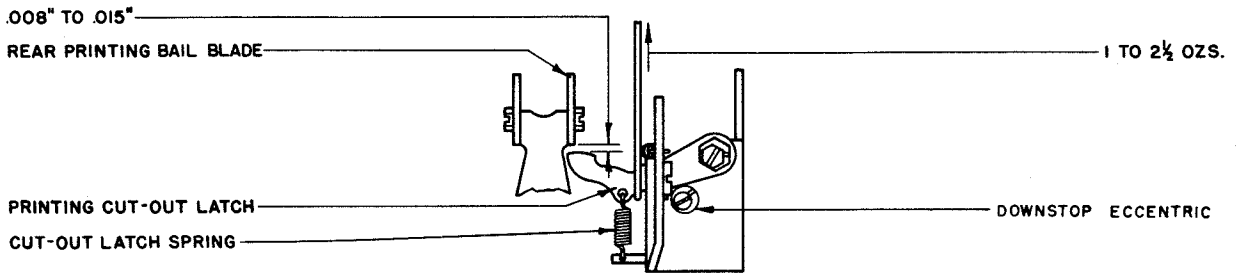

FIGURE 129

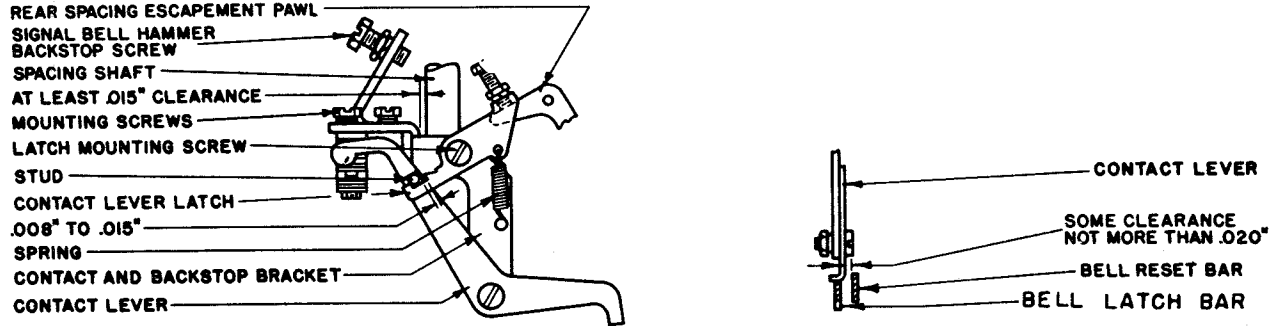

FIGURE 130

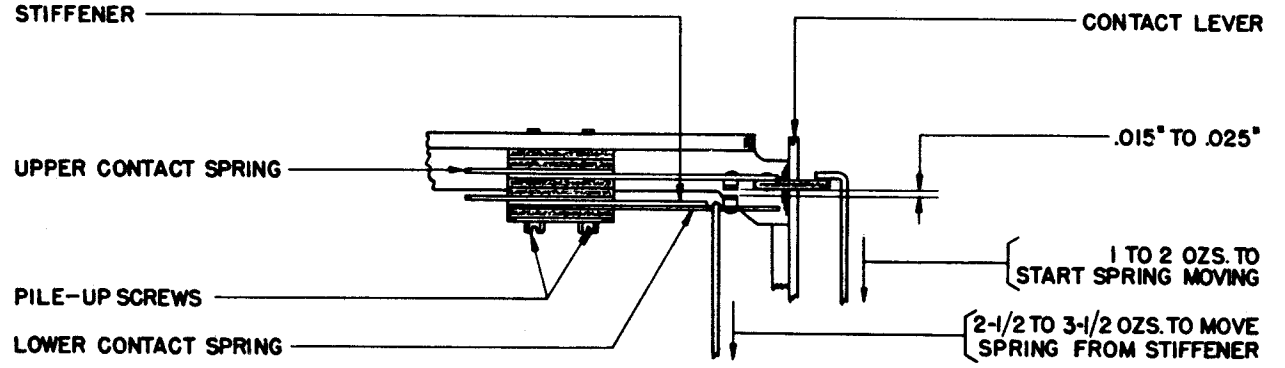

FIGURE 131

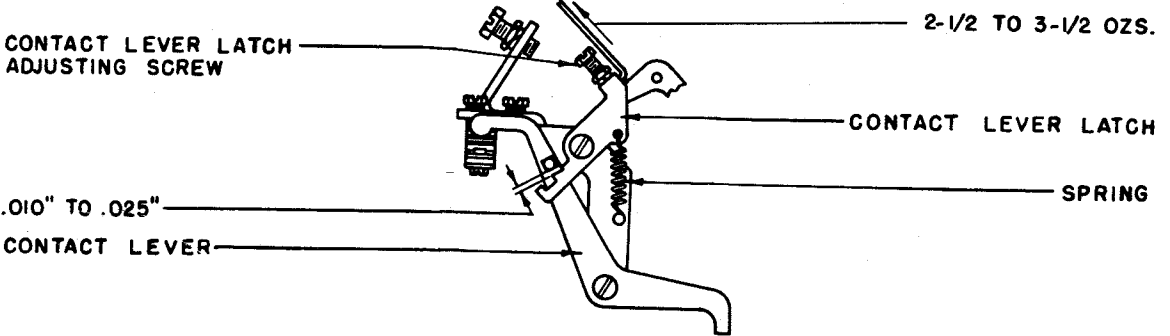

FIGURE 132

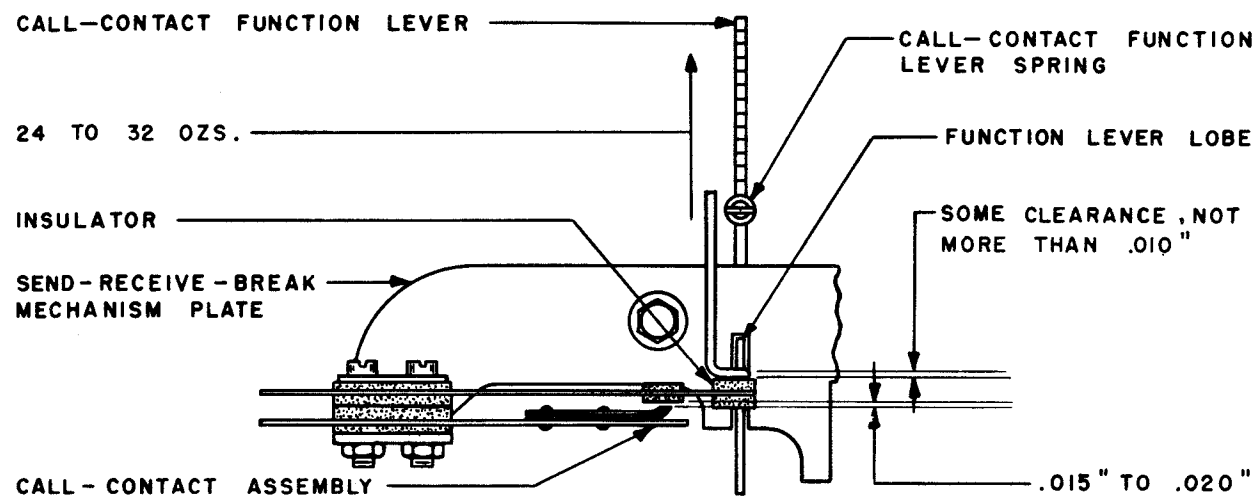

FIGURE 133

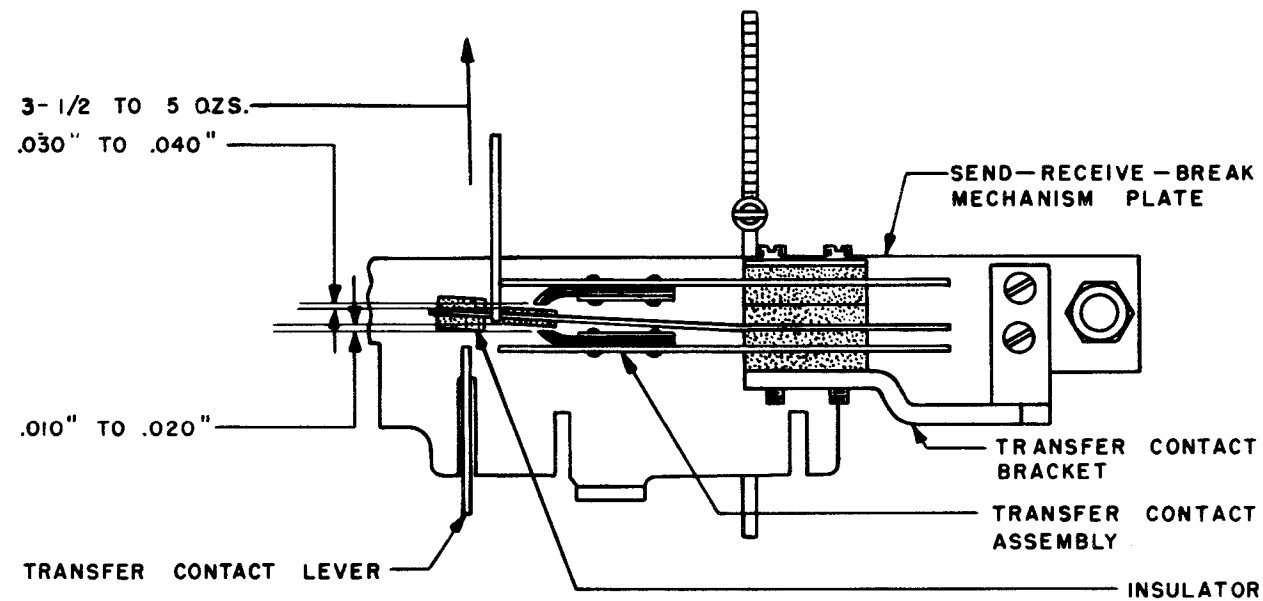

FIGURE 134

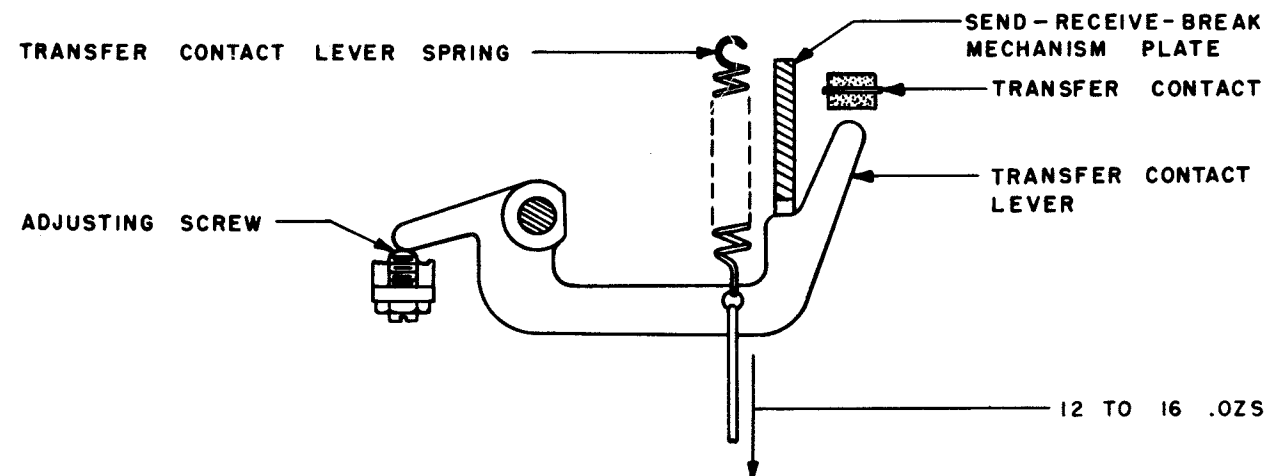

FIGURE 135

138B

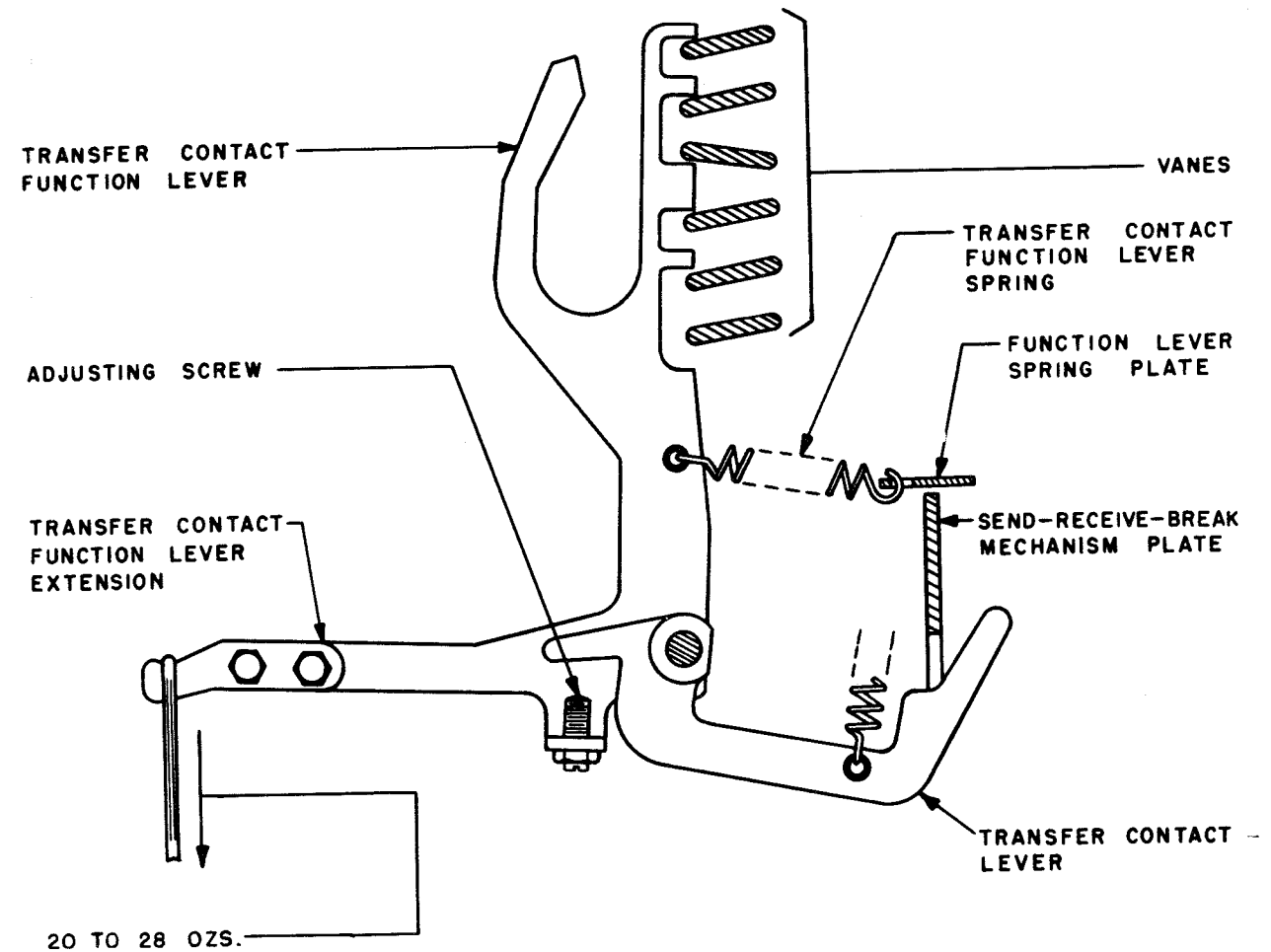

FIGURE 136

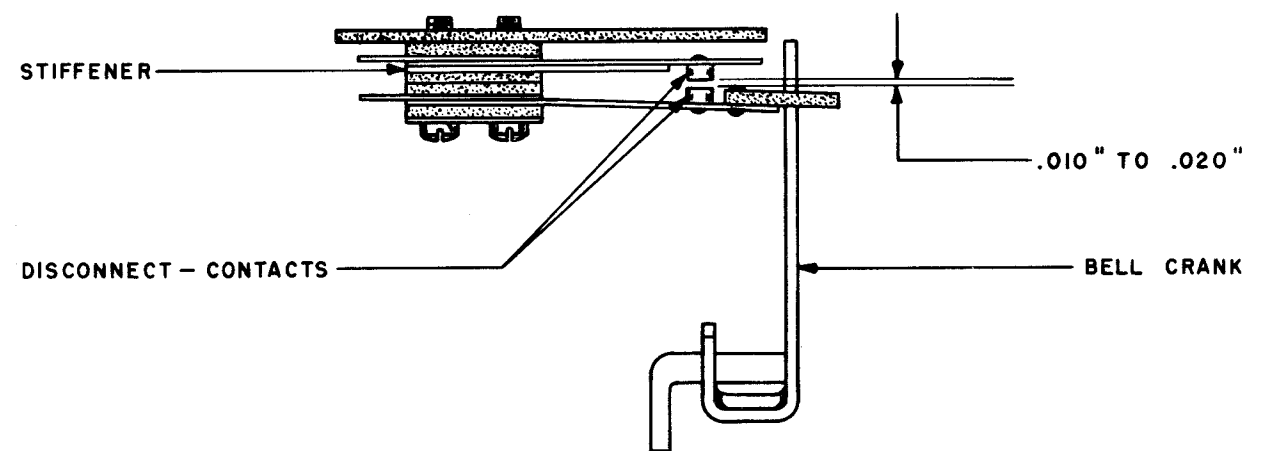

FIGURE 137

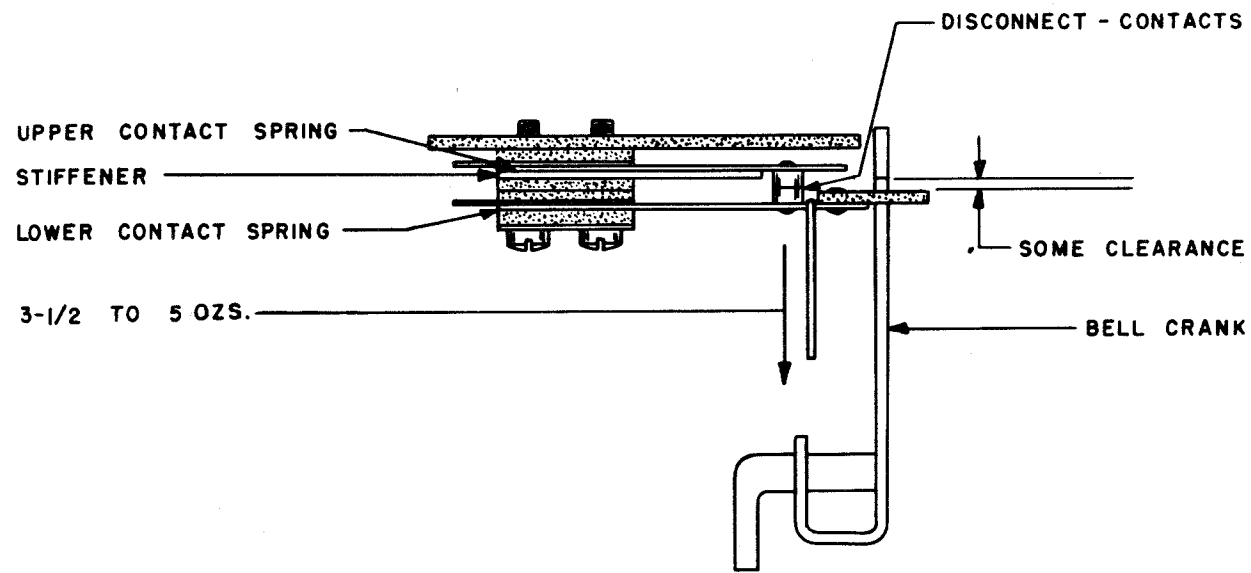

FIGURE 138

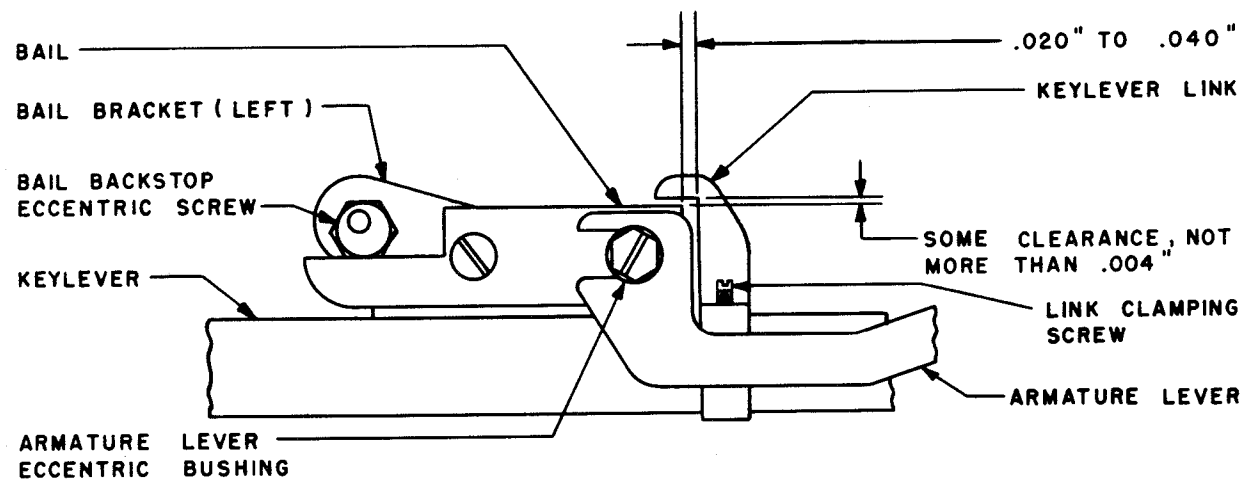

FIGURE 139

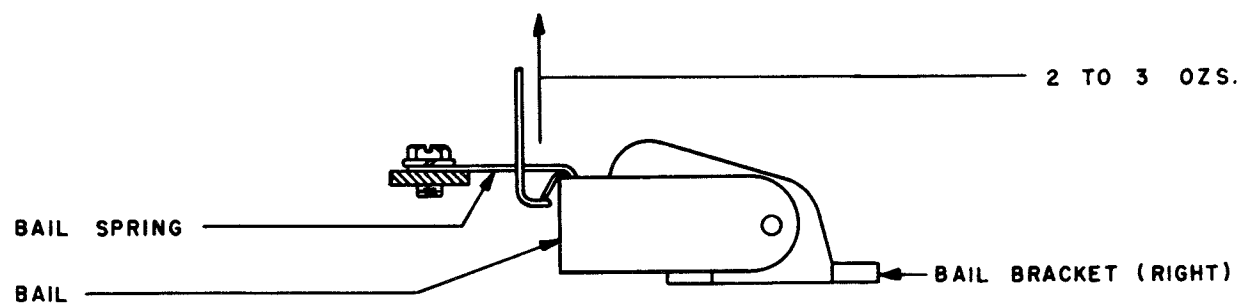

FIGURE 140

ORIGINAL

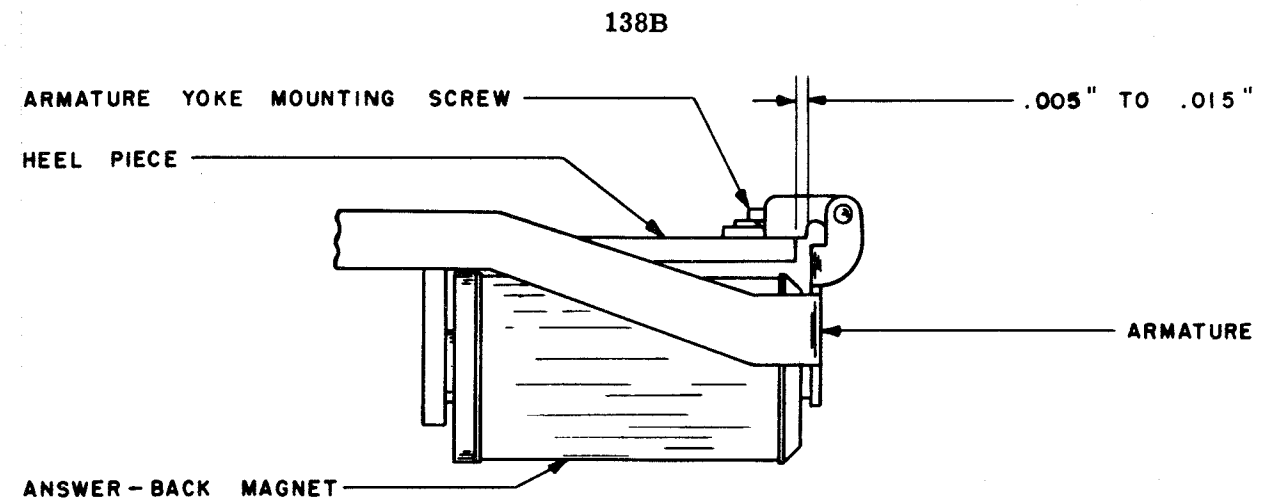

FIGURE 141

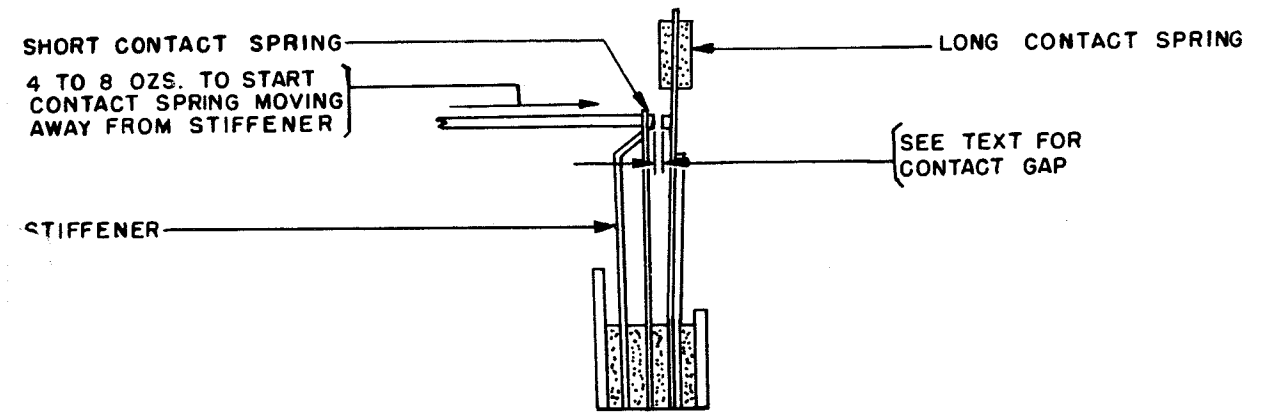

FIGURE 142

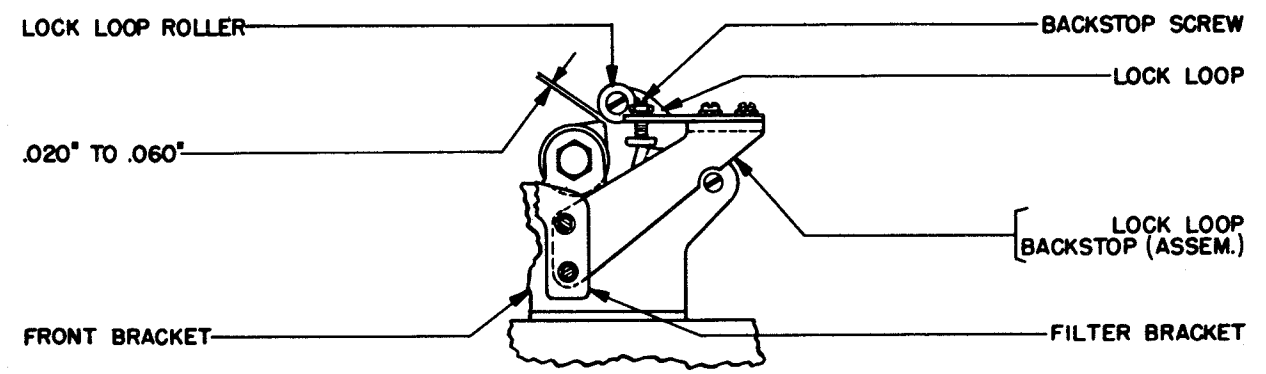

FIGURE 143

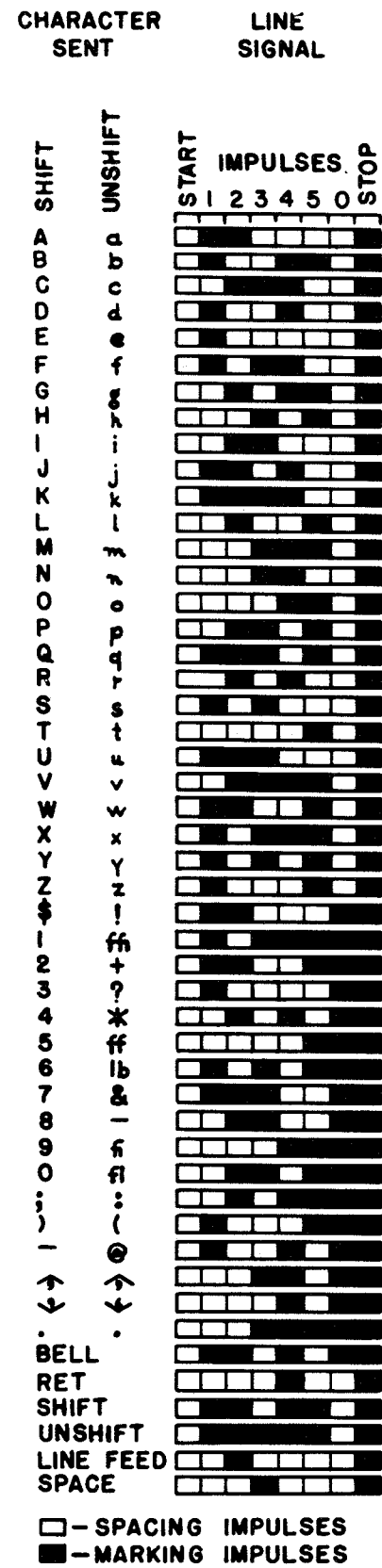

FIGURE 144

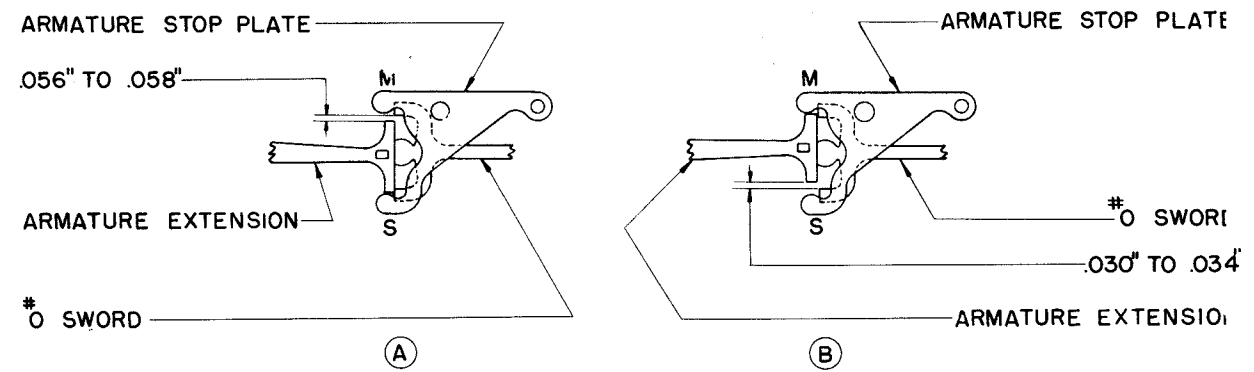
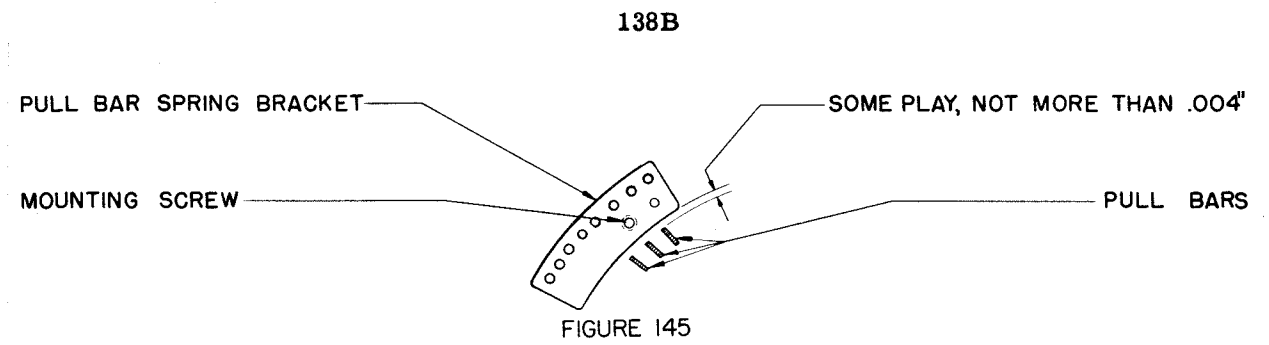

FIGURE 146

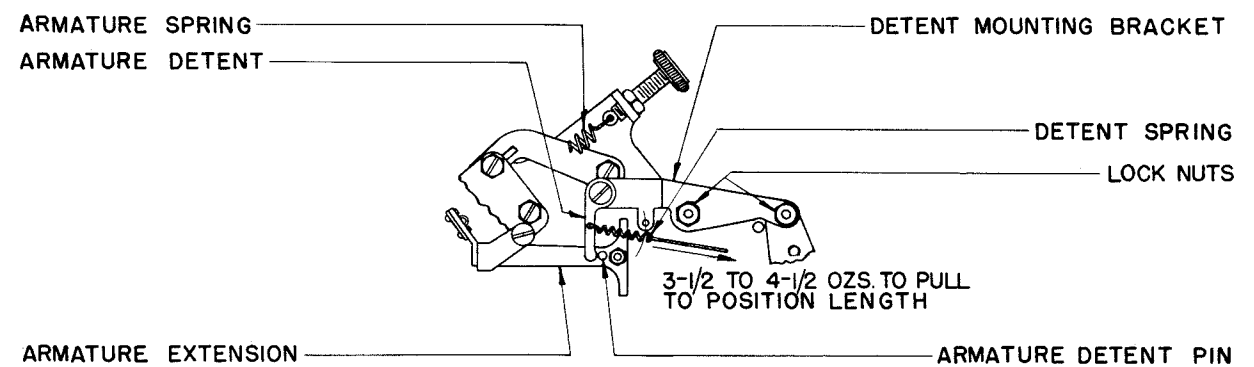

FIGURE 147

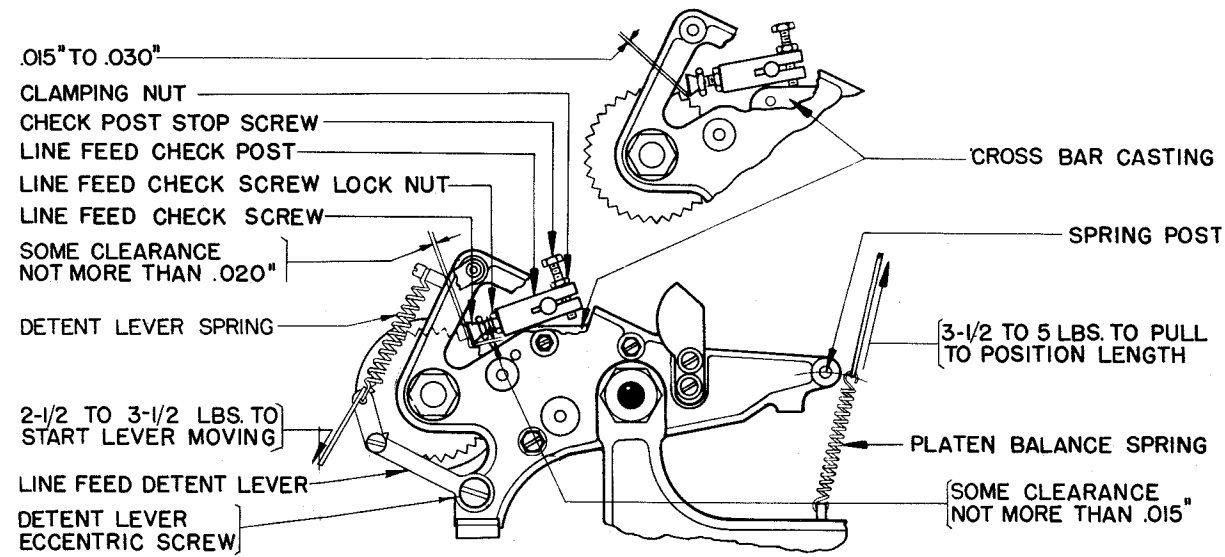

FIGURE 148

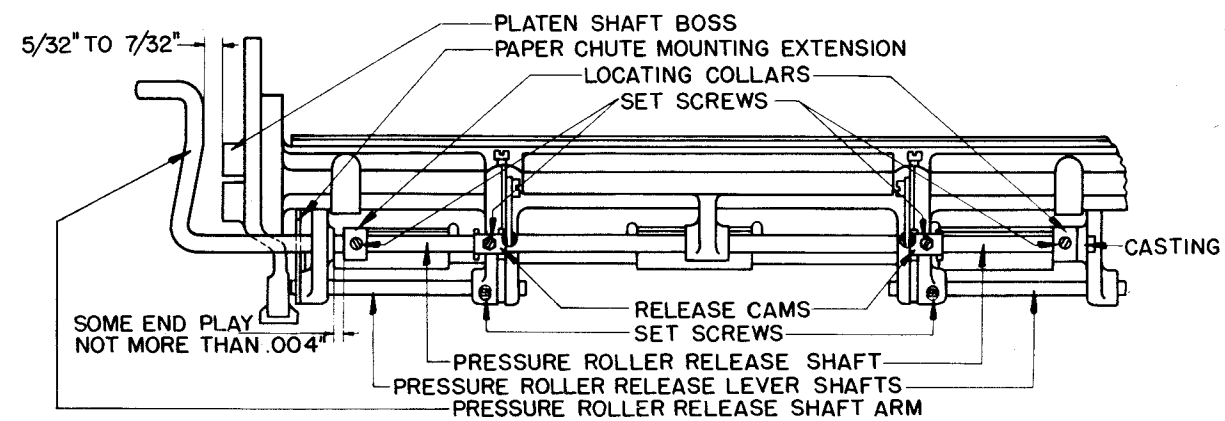

FIGURE 149

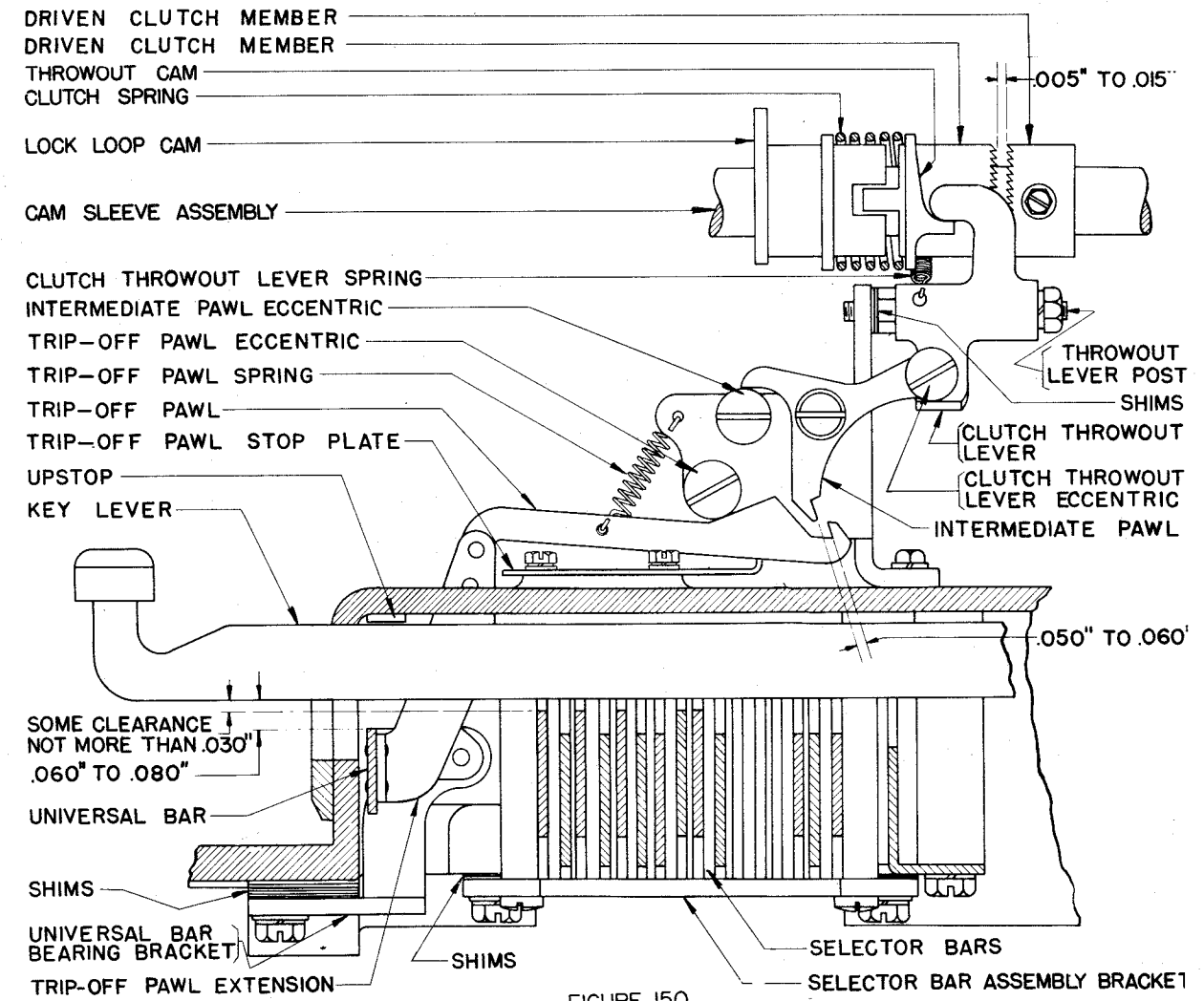

FIGURE 150

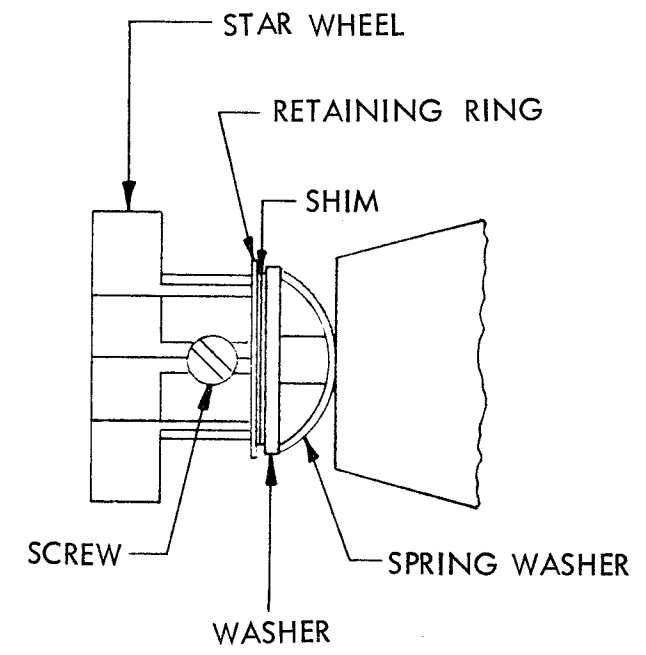

FIGURE 151