

WB 8/27/34

Bulletin No. 150  
Issue 1  
July, 1934

# TELETYPE

PRINTING TELEGRAPH SYSTEMS

Not Full System

THE THEORY,  
OPERATION AND INSTALLATION  
OF  
MULTIPLEX REGENERATIVE REPEATERS

**TELETYPE**  
CORPORATION  
SUBSIDIARY OF  
*Western Electric Company*  
CHICAGO, U.S.A.

## Contents

	Page
Introduction . . . . .	1
Theory of Operation . . . . .	1
Correction Circuit . . . . .	1
Holding Relay . . . . .	2
Selecting Circuit . . . . .	3
Shunted Condenser . . . . .	3
Leak Winding of Transmitting Relay . . . . .	3
Local Meter . . . . .	3
Regenerative Action . . . . .	3
AC for Balancing . . . . .	4
Reading Relay . . . . .	4
Conversion to High-Speed Repeater . . . . .	4
Relay Adjustments . . . . .	4
Fork Adjustments . . . . .	4
Method of Matching Speed . . . . .	5
Corrector Magnet Adjustment . . . . .	6
Switches . . . . .	6
Balancing . . . . .	8
Line Relay Vibrating Circuit . . . . .	8
Tuning Fork Wiring . . . . .	9
Location of Fork Weights . . . . .	9
Installation . . . . .	10
Magnet Resistance Values . . . . .	11

## Drawings

	Figure
Complete Theoretical Circuits . . . . .	1
Correction Circuit . . . . .	2
Holding Relay Circuit . . . . .	3
Selecting and Locking Circuit . . . . .	4
Regenerative Action . . . . .	5
"AC" Circuit . . . . .	6
Fork Contact Spring and Brace Adjustment . . . . .	7
High Speed Jack Circuits . . . . .	8
Corrector Magnet Circuit . . . . .	9
Switch Positions . . . . .	10
Line Relay Vibrating Circuit . . . . .	11
Panel Box Connections . . . . .	12
Panel Box Battery Connections . . . . .	13
Fork Wiring . . . . .	14
Fork Adjustments . . . . .	15
Regenerative Repeater Main Line Connections . . . . .	16

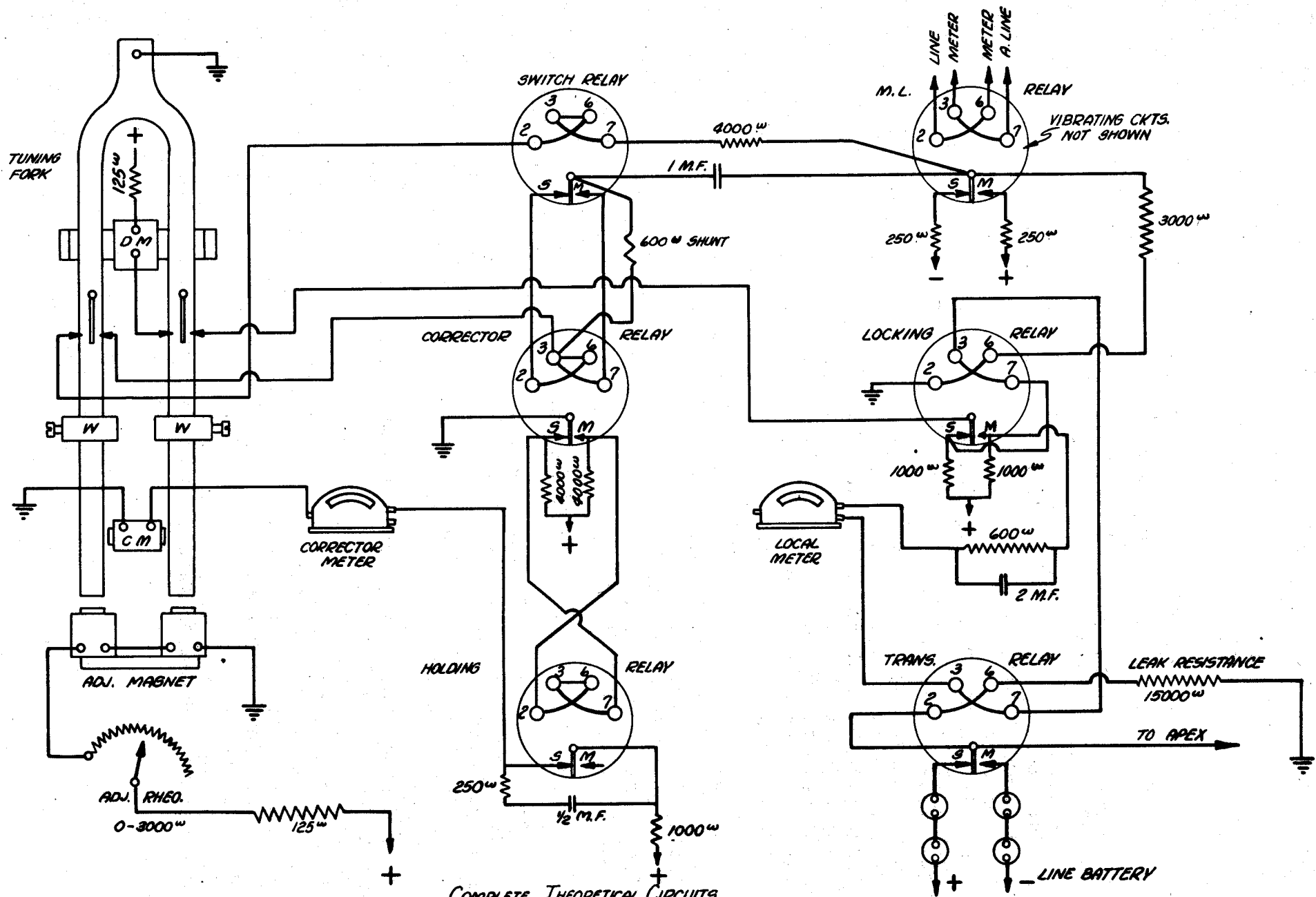

COMPLETE THEORETICAL CIRCUITS  
FIGURE 1

THE THEORY,  
OPERATION AND INSTALLATION  
OF  
MULTIPLEX REGENERATIVE REPEATERS

Introduction

The purpose of this specification is to describe the theory, operation and installation of the regenerative repeaters to be used on long multiplex printer circuits.

Repeaters are used in telegraph circuits for the purpose of strengthening the current and minimizing the detrimental effects of induction from other wires. Where a line is too long to permit direct operation at satisfactory speeds, repeaters are inserted to divide the line into short sections.

The ordinary type of duplex repeater strengthens the current for the next line section, but does not correct any variation in the lengths of the signals. It may, dependent upon the adjustments, add somewhat to the distortion. This additional distortion, however, is not serious in comparison with the other benefits derived from the repeater.

Where a circuit is long and contains many repeaters, it is not possible to maintain as high a speed of operation as on the shorter circuits due to the accumulative distortion of the signal caused by the many line sections and repeaters.

The regenerative repeater as described in this specification, not only strengthens the current for the next line section, but will also correct any distortion of the received signals, so that the repeated signals will be as perfect as the signals originally sent from the transmitting terminal station.

The regenerative repeater for each direction of transmission consists, essentially, of a main line relay, a locking relay, a tuning fork, which is influenced by a correcting circuit and caused to vibrate in synchronism with the received signals, and a transmitting relay which passes the regenerated signals to the next line section. The rate of vibration of the tuning fork must be set to correspond with the operating speed of the circuit.

One or more repeaters of this type may be used in each long printer circuit to permit a higher speed of operation to be maintained and to reduce the time lost in balancing. One advantage of these repeaters is the reduction in the time necessary for the "lining up" of long circuits. The repeater can generate an A.C. locally, which is used in "lining up" the line sections between regenerative repeaters, allowing each section to be balanced simultaneously.

Theory of Operation

Figure 1 shows the theory of the repeater for one-way operation. The main line relay is actuated by the received line signals. The switch relay, corrector relay and holding relay are used for the purpose of maintaining the fork in synchronism with the received line signals. The locking and transmitting relays in connection with the tuning fork permit the regeneration of the signal. The driving magnet DM drives the fork. Small changes and refinements in the speed of the fork are made by means of the adjusting rheostat.

Correction Circuit

Figure 2 shows the theory of the correction circuit. For simplicity in explanation, the corrector magnet of the fork is shown as directly connected to the corrector relay, although actually the corrector relay operates the holding relay and it, in turn, opens and closes the corrector magnet circuit.

By means of the weights W and the adjusting rheostat, the rate of vibration of the fork is set, so that with no current flowing through the corrector magnet, it will make slightly less than a complete cycle of vibration for each unit length of line signal. With current flowing through the corrector magnet, the fork will be speeded up so that it will make slightly more than a complete cycle of vibration for each unit length of line signal. In actual operation, the current through the corrector

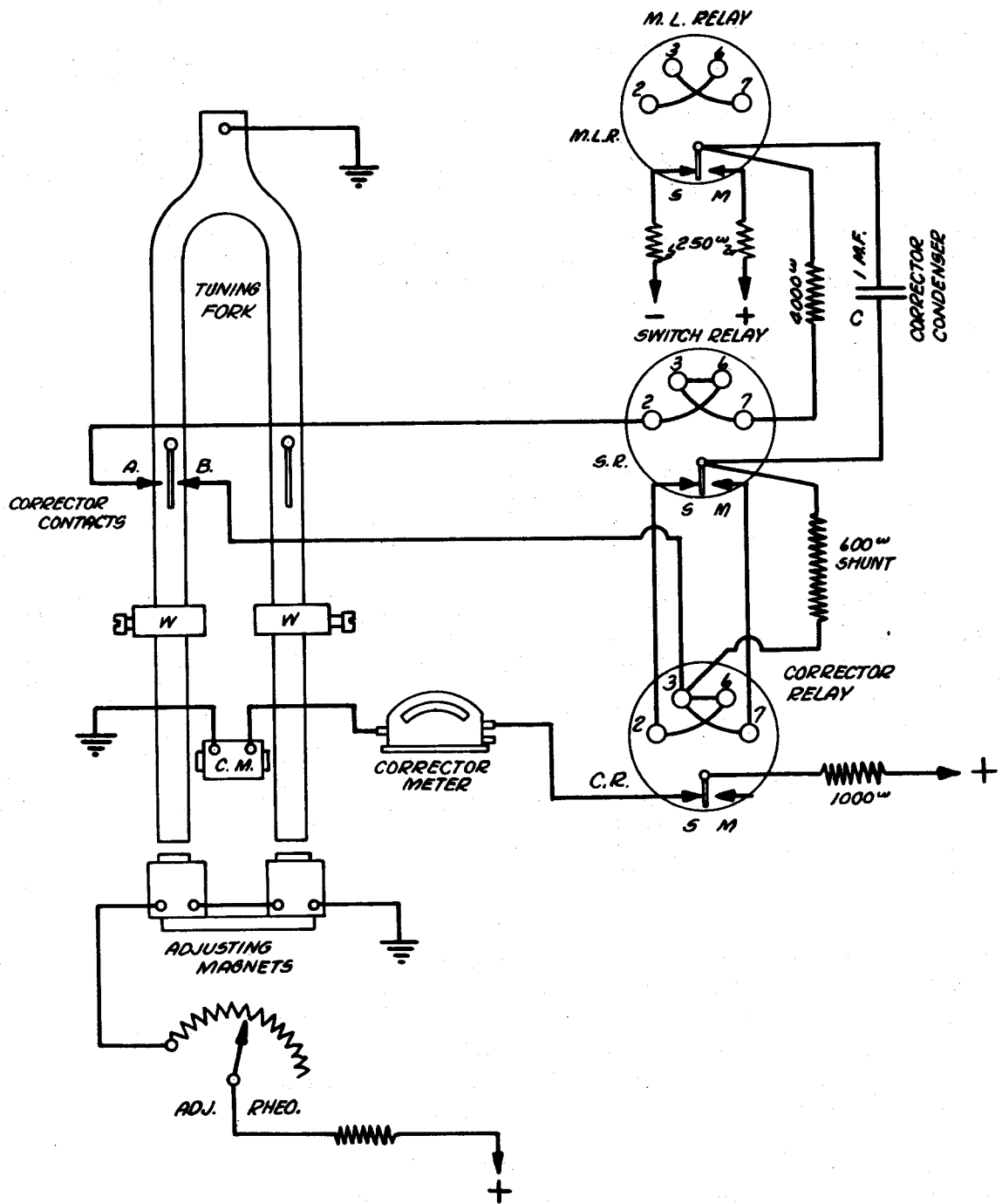

CORRECTION CIRCUIT  
FIGURE 2

magnet will be intermittent and occurring at irregular intervals (due to the correction circuit) and the fork will be held in step with the received signals. When the fork falls behind the signals, current will flow through the corrector magnet and cause the fork speed to increase. When the fork gains on the signals, the current will be cut off the corrector magnet, and the fork speed will be reduced.

Assume, for example, that the speed has been matched and the set is in operation. If the tongue of the main line relay should move from one of its contacts to the other at the instant that the fork is touching contact A (Figure 2), then the tongue of the switch relay SR will be moved to correspond with the position of the tongue of relay MLR. When the fork makes contact with B, there will be a short impulse of current through one winding of the corrector relay (due to the condenser C) and the tongue of relay CR will be moved to the marking contact, and current will cease to flow through the corrector magnet and the fork speed will be reduced. So long as the movements of the tongue of the main line relay MLR occur at the instant that the fork is touching contact A, the relay CR will remain in the marking position. If the movement of the tongue of relay MLR should be from S to M, the tongue of relay SR will be moved to contact M, and the current impulse through the windings of relay CR (due to the condenser), which occurs when the fork touches contact B, will go through one winding of relay CR from right to left and the tongue will be moved to the right. If, however, the movement of the tongue of relay MLR should be from M to S, the tongue of relay SR will be moved to contact S, and the current impulse (due to the condenser) which occurs when the fork touches contact B will be in a reverse direction, but will go through the other winding of the relay CR from right to left and the tongue will still tend to be moved to the right.

The tongue of relay CR being against contact M, no current will flow through the corrector magnet which will decrease the fork speed. In a short time, the movements of the tongue of relay MLR will occur when the fork is on contact B. The impulse from the condenser will take place just as soon as the tongue of relay MLR moves to its opposite contact and as the relay SR will not be affected since the fork is on contact B, the condenser impulse will move the tongue of relay CR to the left, and the current will be applied to the corrector magnet.

A 600 ohm shunt resistance is connected between the tongue of the switch relay and the windings of the corrector relay, so that this resistance shunts one or the other windings of the corrector relay, depending on which contact the switch relay tongue is resting. Part of the condenser discharge will pass through the corrector relay winding, and the remainder through the shunt, thus preventing the impulse from oscillating by providing a non-inductive path for the condenser discharge.

Reviewing the operation of the correction circuit, it will be seen, that if the movements of the tongue of relay MLR occur when the fork is touching contact A, the switch relay tongue will be moved and the condenser impulse, which takes place when the fork moves to contact B, will move the tongue of relay CR to the right and the fork speed will be decreased. If the movements of the tongue of relay MLR occur when the fork is touching contact B, the condenser discharge will occur immediately, and since relay SR has not been operated, the condenser impulse will move the tongue of the relay CR to the spacing or left hand position. Current will flow through the correcting magnet and the fork will increase its speed again. In actual operation the fork corrector contact will be moving, or about to move, from A to B when the movements of the tongue of the relay MLR occur. If the fork should be touching contact A when the tongue of relay MLR moves, the fork speed will be reduced, but if the fork should be touching contact B when the tongue of relay MLR moves, the rate of vibration of the fork will be increased.

#### Holding Relay

The corrector relay is operated by a condenser discharge, and at no time does a steady current flow through its windings. The corrector relay merely serves to operate a holding relay whose contacts control the current to the corrector magnet. Figure 3 illustrates the manner in which the current to the corrector magnet is controlled.

When the corrector relay tongue T is touching contact S, current will flow from positive battery through the resistance R2, through the holding relay windings from left to right, to contact S and to negative through tongue T. Another circuit will be formed through R1 and to ground through tongue T. The holding relay armature will be moved to its S contact.

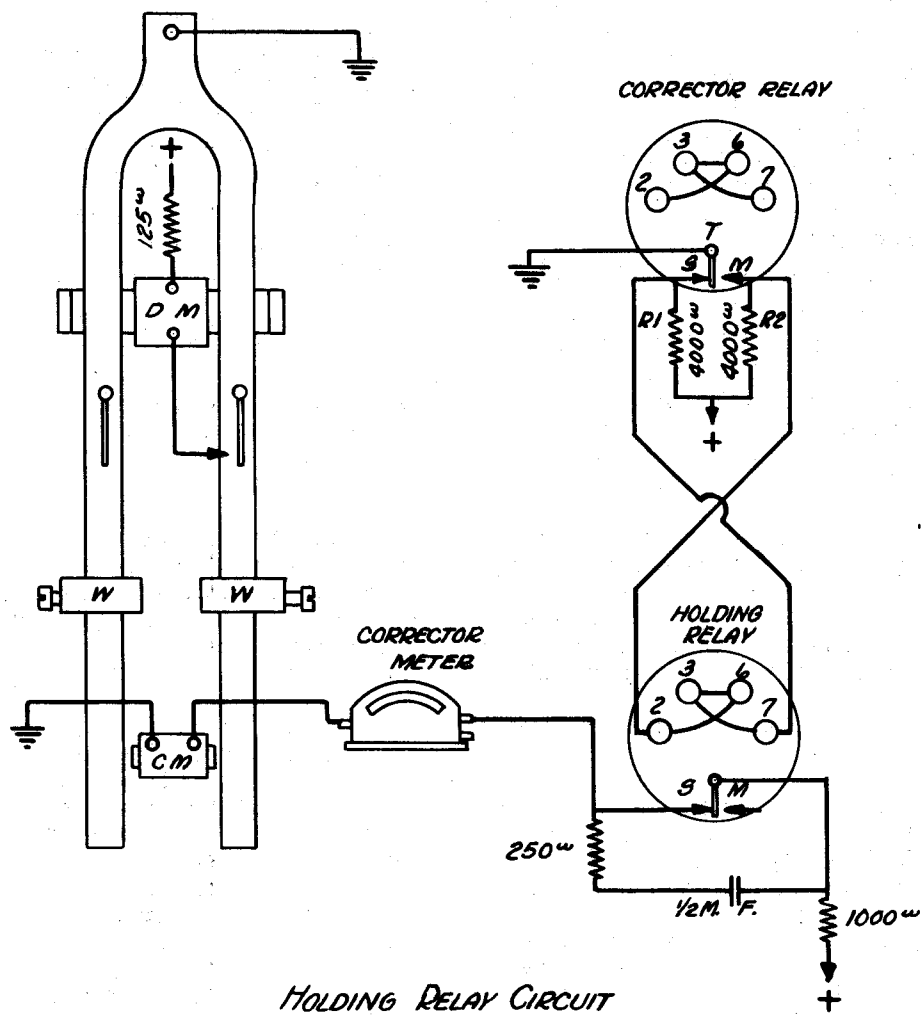

HOLDING RELAY CIRCUIT  
FIGURE 3

When the corrector relay tongue T is touching contact M, current will flow from positive battery through resistance R1, through the holding relay windings from right to left, to contact M and to negative through tongue T. Another circuit will be formed through R2 and to negative through tongue T. The holding relay armature will be moved to its M contact.

This circuit arrangement eliminates any sparking of the corrector relay points, since the windings of the holding relay are always in a closed circuit.

#### Selecting Circuit

Figure 4 shows the theory of the selecting circuit. The locking relay is normally under the influence of the main line relay which controls the direction of the current through the operating winding. The current through the locking winding of the locking relay is stronger than the current in the operating winding, and so long as the fork is touching its selecting contact, the armature of the locking relay is prevented from moving. Of course, during the period when the fork is not touching the selecting contact, there will be no current in the locking winding of the locking relay, and it will be under the influence of the tongue of the main line relay. The polarity of the signal transmitted by the transmitting relay will depend upon the position of the tongue of the locking relay at the MOMENT THE FORK TOUCHES ITS SELECTING CONTACT. A long duration of contact of the fork with the selecting contact is not detrimental to the repeated signals. The locking up of the locking relay while the transmitting relay is operated, due to the fork touching the selecting contact, prevents clipped signals being transmitted from the transmitting relay. The repeated signals will be of full unit or multiple unit length.

#### Shunted Condenser

The shunted condenser shown in Figure 4 is to permit a sharp rise and fall of current in the locking winding. It tends to neutralize the self-inductance of the locking winding when the fork breaks away from the selecting contact. If it were not for this shunted condenser, the magnetic effect of the locking current would take some time to fall to zero and would delay the action of the relay. When the fork breaks away from the selecting contact, the shunted condenser discharges and opposes the residual effect of the locking current.

#### Leak Winding of Transmitting Relay

A circuit from the tongue of the transmitting relay goes through one of the windings of that relay and through a high resistance leak to ground (See Figure 4). The small current passing through the leak winding tends to hold the tongue of the relay to whichever contact it may be placed. This is to insure that the tongue of the relay will not be jarred from the contact during the period of "no current" in the operating windings. The current in the leak winding is small and does not interfere with the operation of the relay.

#### Local Meter

The local meter shown in Figure 4 is used as a guide in checking speed. A "break-up" in the outgoing A.C. may be detected by means of this meter.

#### Regenerative Action

As previously explained, the correction circuit holds the fork in step with the line signals. The fork will make a complete cycle of vibration for each unit length of line signal. If, for instance, the distant terminal is sending A.C. at the rate of 25 cycles (50 units) per second, the fork will be vibrating at 50 cycles per second.

The received signals will operate the main line relay which, in turn, will operate the locking relay. The fork will touch its selecting contact once for each unit length of received signal. The instant of reversal of the signal on the transmitting relay will be defined by the vibration of the fork against its selecting contact. As the tuning fork will maintain a very constant rate of vibration, the repeated signals will reverse at properly timed intervals.

Figure 5 shows graphically the regenerative action of the repeater. It should be noted that the time of operation of the transmitting relay coincides with the instant



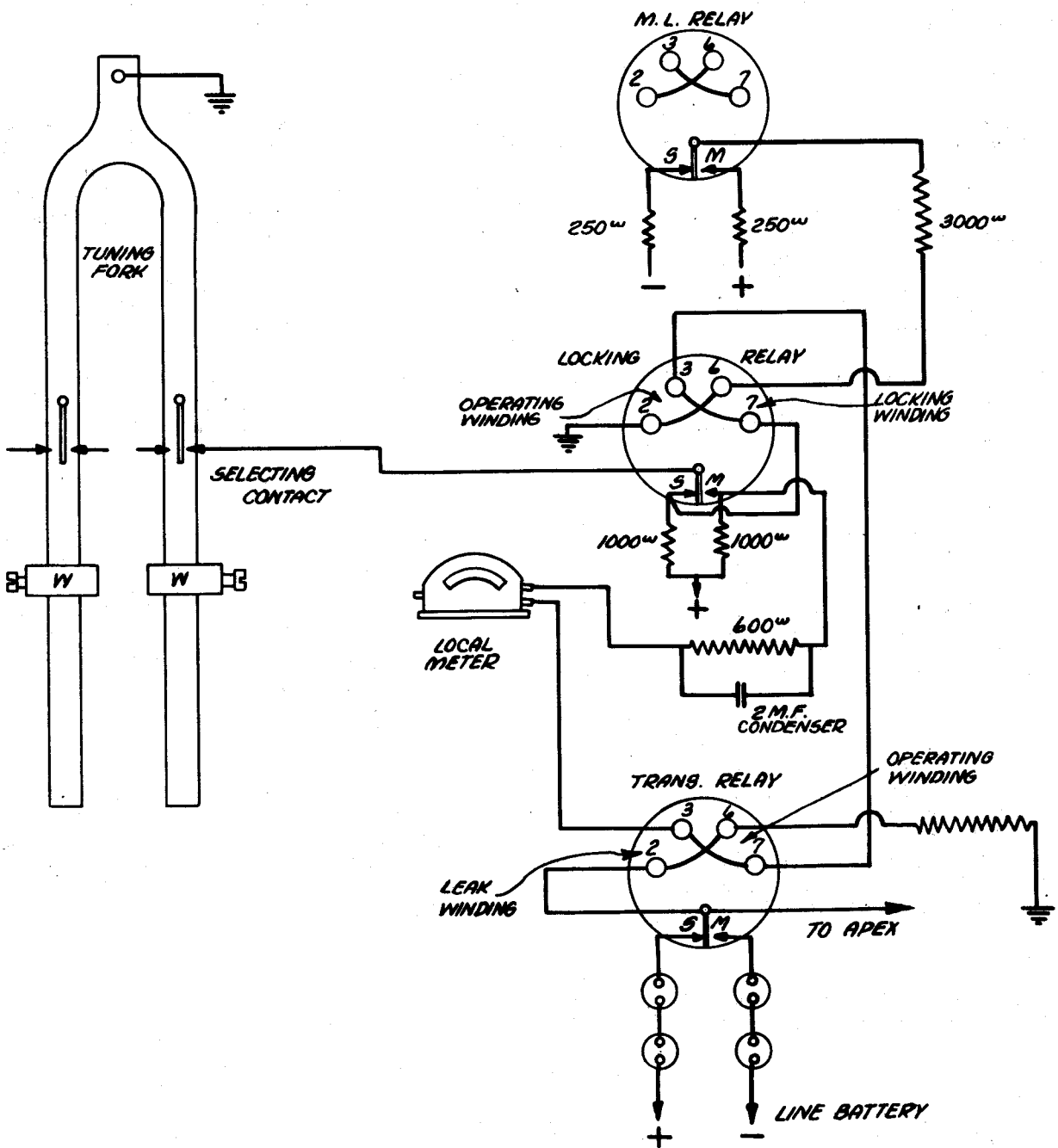

SELECTING AND LOCKING CIRCUIT  
FIGURE 4

of contact of the fork with the selecting contact.

The arrangement of the correcting system and other circuits in this repeater is such that the center or best part of the received signal will be used, at any speed within the range of the fork.

#### "A.C." for Balancing

Provision has been made for generating A.C. at the repeater for balancing purposes. Referring to Figure 6, the double pole A.C. switch, when thrown to the left, will cause A.C. to be sent out from the transmitting relay. In the normal right hand position of the A.C. switch, the operating winding of the locking relay is connected to the tongue of the main line relay, and the leak winding of the transmitting relay goes to ground through 15,000 ohms resistance. When the A.C. switch is in the left hand position, the operating winding of the locking relay is connected to the tongue of the transmitting relay through a 7500 ohms resistance. This leak current through the operating winding of the locking relay will normally hold the tongue of the locking relay in a position opposite to that of the transmitting relay. When the fork touches its selecting contact, the tongue of the transmitting relay will move in the usual manner to a position corresponding to that of the locking relay. As the tongue of the transmitting relay moves, the current through the operating winding of the locking relay will, of course, reverse, but the locking relay will not be immediately affected because the current in the locking winding prevents the operation of the relay. When the fork breaks away from the selecting contact, the locking current will cease and the locking relay tongue will, under the influence of the leak current from the transmitting relay, move to the opposite side. From the foregoing, it will be seen that when the fork touches its selecting contact, the transmitting relay tongue moves to a position similar to that of the locking relay, and when the fork breaks away from the selecting contact, the locking relay tongue will move to a position dissimilar to that of the transmitting relay. The A.C. generated in this manner will be of the same frequency as the A.C. from the terminal multiplex sets.

#### Reading Relay

The reading relay is used to operate the sounder and selector and is operated by means of a leak from the tongue of the main line relay. See Figure 8.

#### Conversion to High Speed Repeater

When the two jacks shown in Figure 8 are connected together with a double conductor cord, the transmitting relay will be directly connected in series with the reading relay windings, the leak circuit from the transmitting relay tongue will be opened, and the set will function as a regular high speed repeater but, of course, there will be no regenerating action. When the set is operating as a high speed repeater, the fork may be stopped and the switch relay, corrector, and locking relays may be removed, if necessary, without causing trouble.

It should be noted that when the set is "cut through" as a high speed repeater, the continuity of the locking circuit is maintained, even though the transmitting relay is out of the circuit. This feature permits the speed to be matched and signals observed on the local meter while the set is "cut through" as a high speed repeater without interfering with the repeated signals.

#### Relay Adjustments

The main line, locking, transmitting, switch and reading relay tongues should be given a .004" travel, and should be kept centered. The corrector and holding relay tongues should be given a .012" travel. The corrector and switch relays should be free from binds and should be very carefully centered, since improper action of these relays could cause poor correction and loss of synchronism. The holding relay may be centered when the corrector relay is out of the clips.

#### Fork Adjustments

##### Contact Spring Supports Adjustment

The contact springs of the forks are provided with braces or supporting springs which should be adjusted as follows:

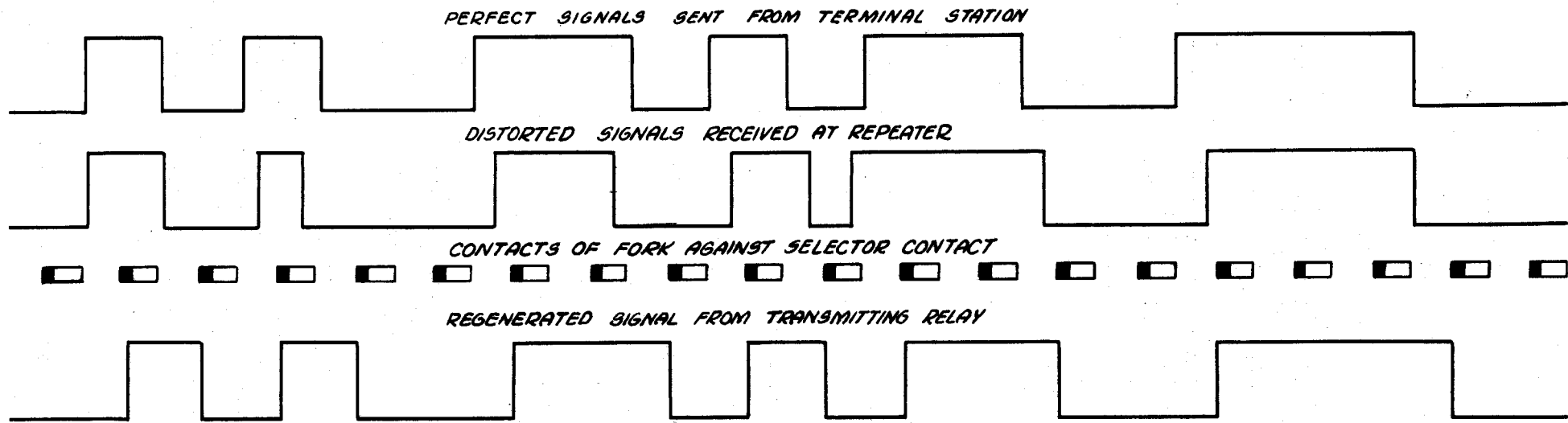

REGENERATIVE ACTION

FIGURE 5

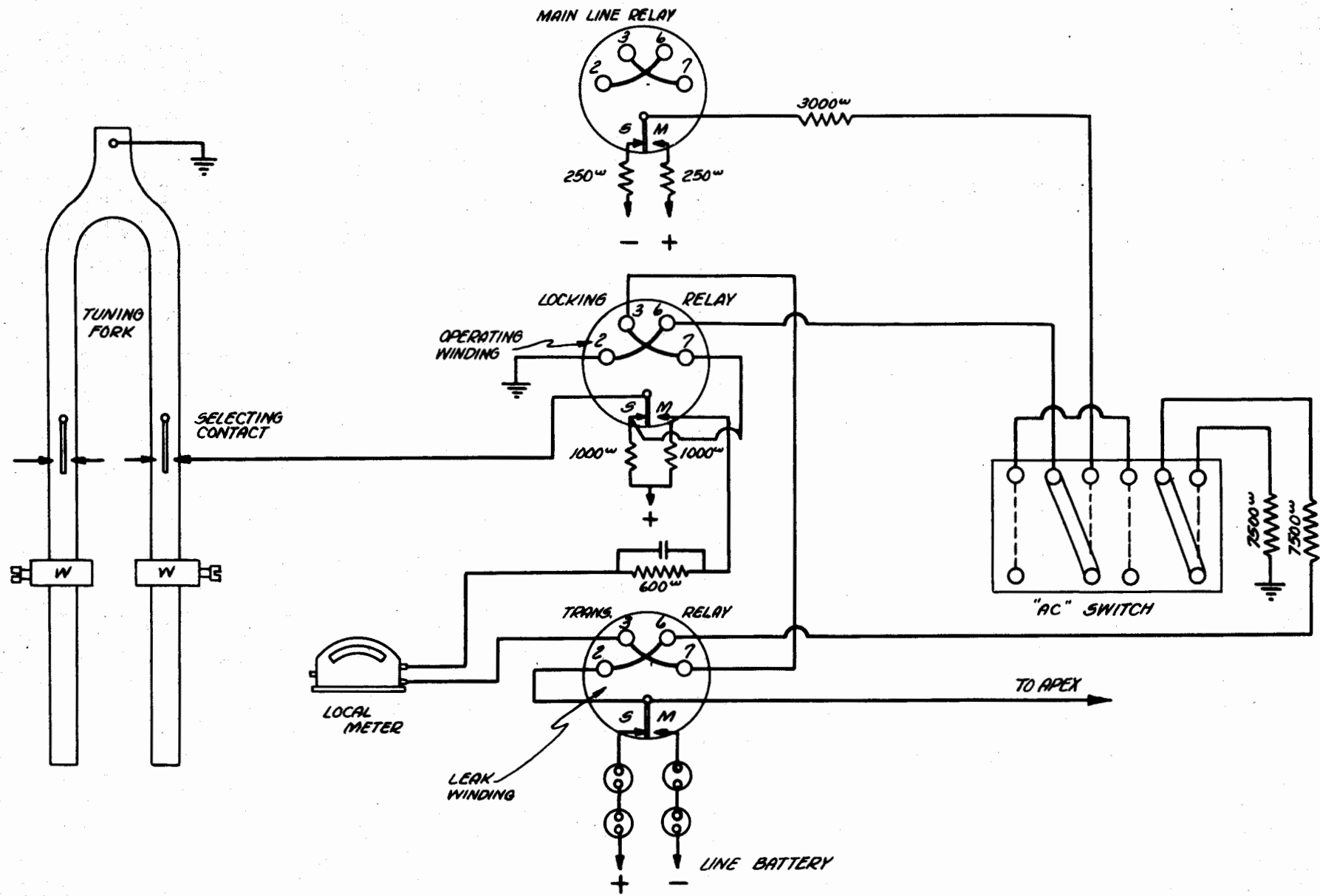

"AC" CIRCUIT  
FIGURE 6

Back off the contact screws, loosen the spring clamping screw, and remove the supporting springs. Bend the supporting springs so that their tips will press firmly against the contact spring when clamped to the fork. This adjustment should be checked at regular intervals by backing off the contact screws and moving the contact spring from side to side. The supports should follow the contact spring for a short distance in either direction. Figure 7 shows the correct manner of bending.

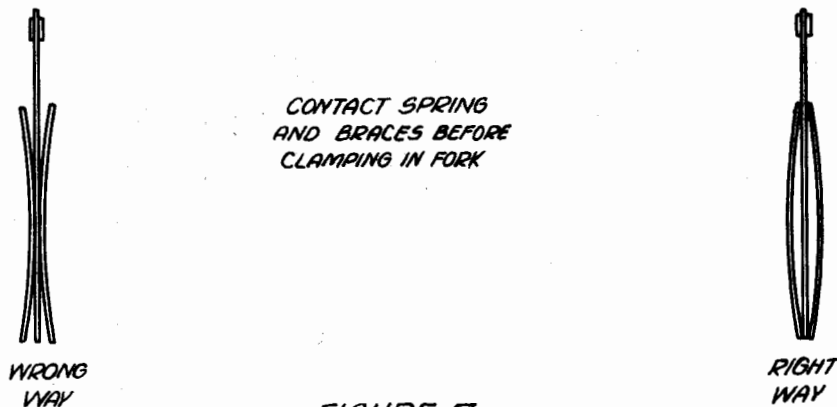

#### Contact Adjustments

With the contact springs in a vertical position, adjust the contact screws so there will be .003" gap between each contact screw and the contact spring. See Figure 15.

#### Driving Magnet Pole Gap

There should be an equal amount of clearance between the driving magnet pole pieces and either tine of the fork. This gap may be adjusted by loosening the screws which hold the driving magnet and pole pieces to the base casting and moving the coil which is fastened to the pole pieces. See Figure 15.

#### Adjusting Magnet Pole Gap

There should be a clearance of .010" between the end of the adjusting magnet cores and the end of the fork tines. This gap is adjusted by moving the adjusting magnet bracket either backward or forward. See Figure 15.

#### Corrector Magnet Pole Gap

The corrector magnet pole pieces should be set approximately  $1/32$ " from the fork tines and parallel to them. See instructions for checking speed for exact adjustment of corrector magnets.

#### Method of Matching Speed

The speed should be matched when the terminal station is running A.C. First set the weights on the fork in an approximate position for the operating speed, in accordance with the table of weight settings given on page 9 of this specification. Place the corrector switch in its normal position (to the right). Turn the adjusting rheostat to the extreme clockwise position and watch the "break-ups" of the A.C. on the local meter. Also turn the adjusting rheostat to the extreme counter-clockwise position and watch the "break-ups". If the "break-ups" are less frequent when the rheostat is turned to its extreme clockwise or slow position, it will be necessary to make the speed of the fork slower by moving the weights forward. If, however, the "break-ups" are less frequent when the rheostat is turned to its extreme counter-clockwise or fast position, it will be necessary to make the speed faster by moving the weights backward. With the adjusting rheostat set so that there are no "break-ups" in the A.C. of the local meter, the speed should be refined by turning the

rheostat slowly in the direction which the corrector needle favors--that is, if the needle favors the "zero" position, the rheostat should be turned clockwise, and if the needle favors the left or "marking" position, the rheostat should be turned counter-clockwise. When the corrector meter is working evenly so that it does not remain in the "marking" position longer than it remains in the "zero" position, the speed is about right. If, in making the final speed adjustment, it is found that the rheostat setting is too near its extreme clockwise limit, when even working of the corrector meter has been attained, the fork speed should be decreased by moving the weights forward a very slight amount, so that the indicating arm of the rheostat may be brought nearer the center. If it is found that the rheostat setting is too near its extreme counter-clockwise limit, the fork speed should be increased slightly by moving the weights backward. In its final setting, the indicating arm of the rheostat should rest at an angle not greater than 90° from the vertical.

It should be noted that it is not possible to match speed from the west, for example, while A.C. is being sent to the east.

When a regenerative set is idle, practice in matching speed may be had by running A.C. from one half of the set into the other, and matching the local A.C. If A.C. is run from the east half and it is being matched on the west half, the corrector switch on the east half should be opened so that the speed will remain constant.

#### Corrector Magnet Adjustment

The magnetic effect of the corrector magnet on the fork can be varied by moving the corrector magnet pole pieces. The pole pieces will ordinarily be approximately 1/32" from the fork tines. If the magnets are too far from the fork, there will be insufficient correcting effect, and the synchronism will be unstable. It will also be found that the adjusting rheostat will be critical in its adjustment.

To check the proper setting of the corrector magnets, the speed should first be matched in the usual manner at approximately the normal working speed and there should be no "break-ups" on the local meter. Open the corrector circuit by putting the corrector switch in its center position, and count the number of seconds from the start of one "break-up" to the start of the next on the local meter. Next apply steady correction by throwing the corrector switch to left and count the number of seconds from the start of one "break-up" to the start of the next on the local meter. The average of the time intervals between "break-ups" with the corrector current on and off, respectively, should be taken. If, for instance, with correction off, the A.C. on the local meter breaks up every 26 seconds and with correction on, it breaks up every 20 seconds, then the average will be 23 seconds.

If the corrector magnets are properly set, the average time interval from "break-up" to "break-up" when checked in the above described manner should be between 15 and 25 seconds. If the interval is greater than 25 seconds, the corrector magnets should be moved closer to fork, but if interval is less than 15 seconds, the corrector magnets should be moved away from the fork. Each time the corrector magnets are moved, the speed should be adjusted by means of the rheostat to give even working of the corrector meter before timing the "break-ups".

The fork contacts should be cleaned and the setting of the corrector magnets checked at regular intervals. The magnet setting should also be checked whenever it is necessary to change a fork or when trouble in holding speed is experienced.

#### Switches

##### Sounder Switch

Normal position to the left. This switch, when thrown to the right, permits the sounder to receive the impulses from the reading relay.

##### Corrector Switch

The corrector switch, when in the normal right hand position, passes the regular correcting current to the fork. In the central position, the correcting current is cut off from the fork. In the left hand position, steady current is applied to the corrector magnet. This switch is used in checking the adjustment of the fork corrector magnets. See Figure 9.

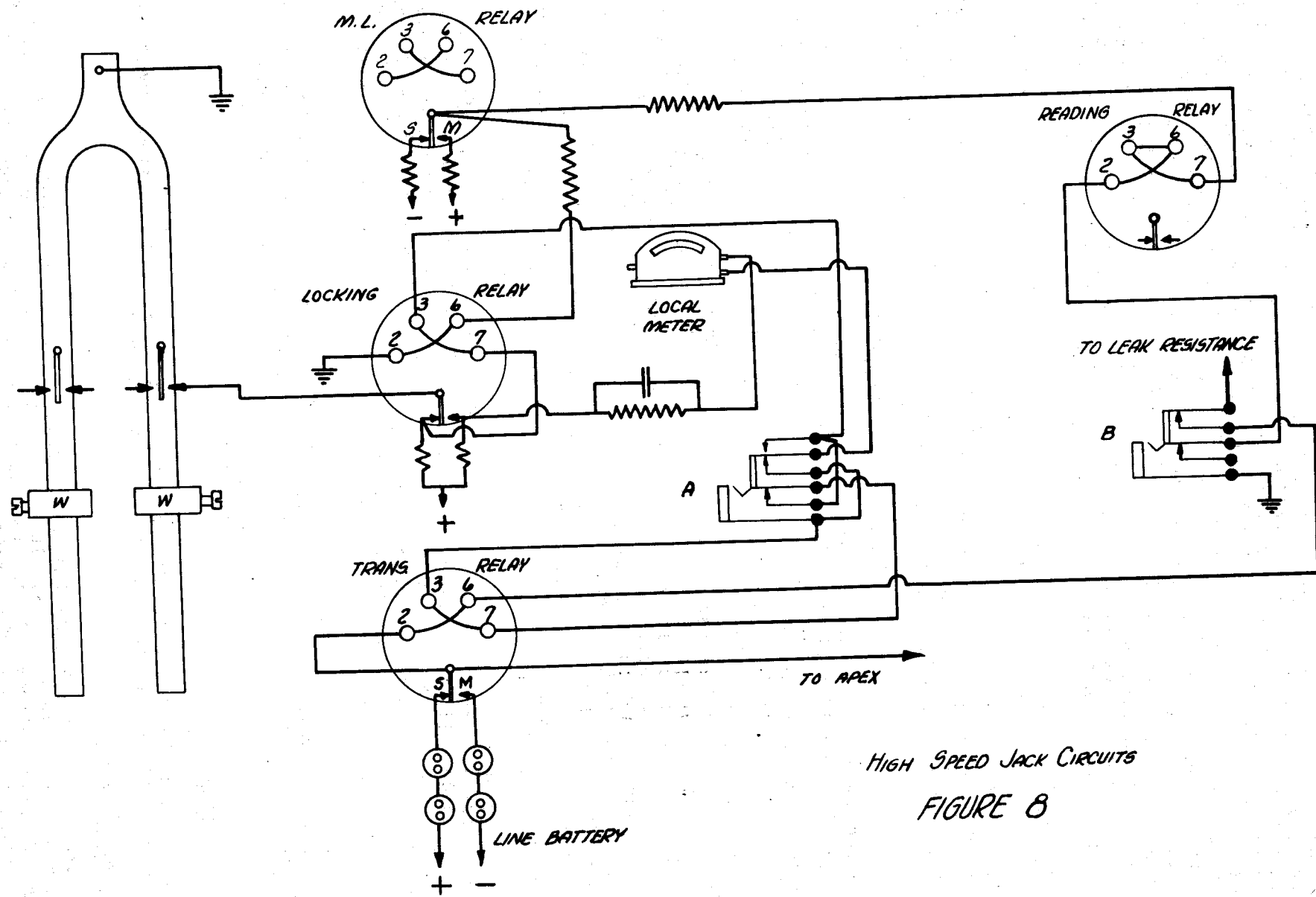

High Speed Jack Circuits  
 FIGURE 8

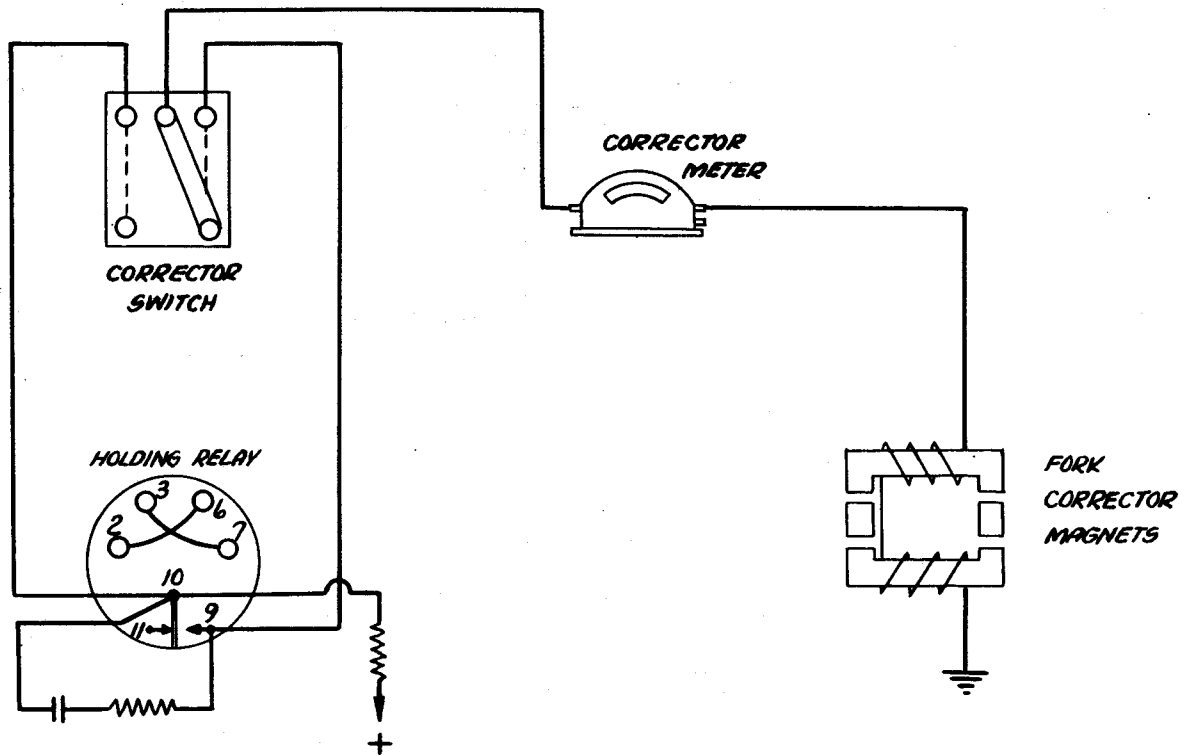

*CORRECTOR MAGNET CIRCUIT  
FIGURE 9*

Ground Switch

Normal position to the right. When thrown to the left, it grounds the apex or left hand terminal of main line meter through a balancing resistance in the artificial line rheostat. See Figure 16.

Line Switch

Normal position to the right. This switch, when in the central position, opens the line. When thrown to the left, the line is directly grounded through no resistance. See Figure 16.

A.C. Switch

Normal position to the right. This switch, when thrown to the left, sends out A.C. for balancing purposes.

Reading Relay Switch

Normal position to the right. With the switch in the normal position, the reading relay responds to the impulses received from the main line relay. With the switch thrown to the left, the reading relay on that side of the set is connected to the transmitting relay, thus permitting the sounder to be used as an audible check on the outgoing regenerated signals.

**CAUTION:** The reading relay switch must be kept in the normal position while the repeater is "corded through" as a high speed set.

Fork Switch

The fork snap switch on the lower shelf, when turned to its "OFF" position opens the driving circuit and stops the fork.



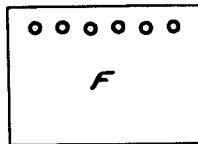
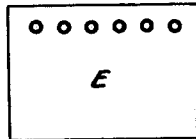
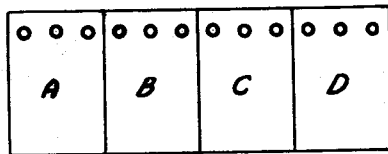

SWITCH POSITIONS

<p><i>A</i></p> <p><i>SOUNDER SWITCH</i></p> <p>← <i>NORMAL</i></p> <p>→ <i>TO READING RELAY</i></p>	<p><i>B</i></p> <p><i>CORRECTOR SWITCH</i></p> <p>→ <i>NORMAL</i></p> <p>← <i>STEADY CURRENT</i></p> <p>↓ <i>CURRENT OFF</i></p>
<p><i>C</i></p> <p><i>GROUND SWITCH</i></p> <p>→ <i>LINE TO BATTERY</i></p> <p>← <i>LINE TO BALANCE</i></p> <p><i>GROUND</i></p>	<p><i>D</i></p> <p><i>LINE SWITCH</i></p> <p>→ <i>LINE CLOSED</i></p> <p>← <i>LINE GROUNDED</i></p> <p>↓ <i>LINE OPEN</i></p>
<p><i>E</i></p> <p><i>A. C. SWITCH</i></p> <p>→ <i>NORMAL</i></p> <p>← <i>TRANS. RELAY</i></p> <p><i>VIBRATING</i></p>	<p><i>F</i></p> <p><i>READING RELAY SWITCH</i></p> <p>→ <i>TO MAIN LINE RELAY</i></p> <p>← <i>TO TRANSMITTING</i></p> <p><i>RELAY</i></p>

FIGURE 10

### Pole Changer Key Switch

Normal position to the left. The small switch on the pole changer key, when in its right hand position, cuts off the transmitting relay from the line circuit and switches the pole changer key into the line so that it may be used for conversational purposes. With the switch to the left, the set will normally operate as a repeater except when the A.C. switch, located directly behind the pole changer key, is thrown to the left causing local A.C. to be sent to the line.

### Line Battery Switch

The line battery switches in the panel box control the voltage applied to the points of the transmitting relays. In the right hand position, the low voltage battery is applied, and in the left hand position, the high voltage is applied.

### Balancing

The circuits on each side of a regenerative repeater should be balanced simultaneously. For example, let X, Y, and Z represent the stations on a circuit with a regenerative repeater at Y. If the attendant at terminal station X wishes to "line up" the circuit, he should first call the attendant at the repeater station Y, who will transmit A.C. from Y to X. The attendant at Y will immediately call terminal station Z, and A.C. will be transmitted from Z to Y. When the A.C. from terminal station Z is properly received at Y, the attendant at Y will then transmit A.C. to station Z. When the A.C. from station Y is properly received at X, the attendant at X will transmit A.C. to Y. When the circuits on each side of the repeater have been balanced, the repeater attendant should notify both terminals and set all switches for normal repeater operation. The terminal sets must then be brought into phase. The repeater attendant must not leave his set until both terminals are in phase.

The terminal station attendant will be unable to see any unbalance, bias, or unsteadiness of the signals which may exist in the line section beyond the regenerative repeater. If the distortion of the signals beyond the regenerative set becomes too great, the terminal station will receive unsteady A.C. If a terminal station is getting unsteady A.C., the nearest regenerative repeater attendant should be asked to watch for it. By watching the operation of the main line and local meters, the condition of the received and repeated signals can be determined. If the signals are received perfectly, but repeated imperfectly, the repeater attendant must locate the trouble. When checking both received and repeated signals, the sounder switch and reading relay switch should be thrown to the left so that the sounder will act as an audible check on the repeated signals while the received signals are being observed on the main line meter. If signals are not received perfectly at a regenerative repeater station, the next regenerative repeater attendant should be notified. It should not be necessary for the terminal attendant to go beyond the nearest regenerative repeater in locating trouble.

While the terminal station attendants will ordinarily decide what speed is to be maintained, the attendant at the regenerative repeater may order it reduced if, due to weather or other conditions, signals do not arrive with normal margin and cannot be regenerated. Before reducing the speed, of course, an attempt should be made to determine the reason for the loss of margin. Sometimes a change of wires will permit normal speed to be maintained.

### Line Relay Vibrating Circuit

Figure 11 shows the theoretical connections of the line relay vibrating circuit. In addition to the regular operating windings, the 1-A relays are provided with two auxiliary windings known as the accelerating winding and opposing winding.

The operating winding is connected to the line in the usual manner. The accelerating winding and opposing winding are connected together and to the condenser and resistances as shown in figure 11. With this circuit, the speed of operation of the relay is greatly increased over that of a 1-B relay, as will be understood from the following explanation:

When the tongue reaches the spacing contact, a rush of current passes to the condenser through the accelerating winding in such direction as to hold the tongue against the spacing contact. At the same time, current flows through the opposing

winding and a resistance in series with it in such direction as to tend to move the tongue toward the marking contact, giving an opposing effect to the current in the accelerating and operating windings. The condenser charging current, however, diminishes to zero, while the current through the opposing winding increases to a steady value which will cause the tongue to move towards the marking contact, when the line current diminishes at the moment of reversal.

As soon as the tongue leaves the spacing contact, battery is cut off and the condenser discharges through the accelerating and opposing coils in a direction to assist the motion of the tongue, thus shortening the transit time. When the tongue reaches the marking contact, the same cycle of operations is repeated, the tongue, of course, tending to move in the reverse direction.

1-A type Wheatstone relays should be used in both main line positions. Either 1-A or 1-B type Wheatstone relays may be used in all other positions.

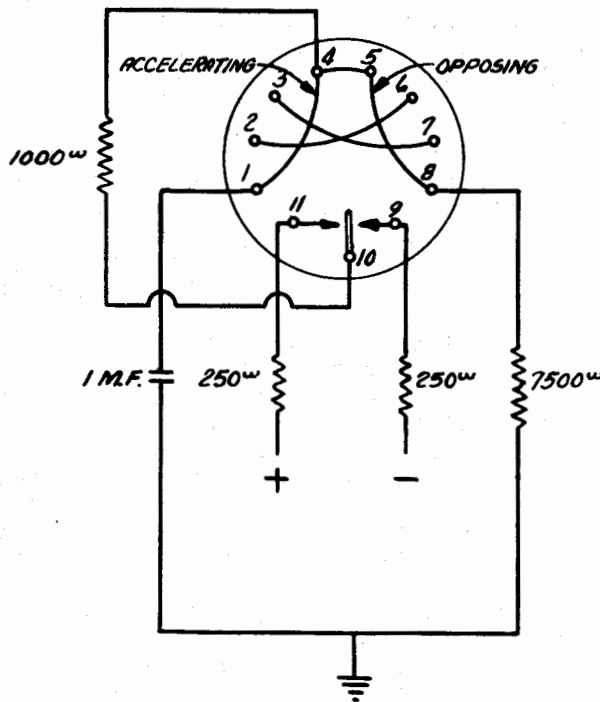

LINE RELAY VIBRATING CIRCUIT  
FIGURE 11

Tuning Fork Wiring

For repeater use, the tuning fork condensers connected to the corrector contacts must be disconnected as shown on Figure 14.

The repeater fork may be used for multiplex printer terminal sets, in which case the condensers should be connected. When used on terminal multiplex sets, the binding post nearest to the front of the fork will not be used.

Approximate Location of Fork Weights for Various Speeds  
(Measure with #6440 Fork Weight Gauge)

<u>At Terminal Set</u>	<u>Word per Min. Speed</u>	<u>At Repeater Set</u>
2 Small, $\frac{1}{4}$ " from stop	52	1 Small, against stop
2 " $\frac{1}{2}$ " " "	51	1 " $\frac{1}{4}$ " from "
2 " 1" " "	50	1 " 1" " "

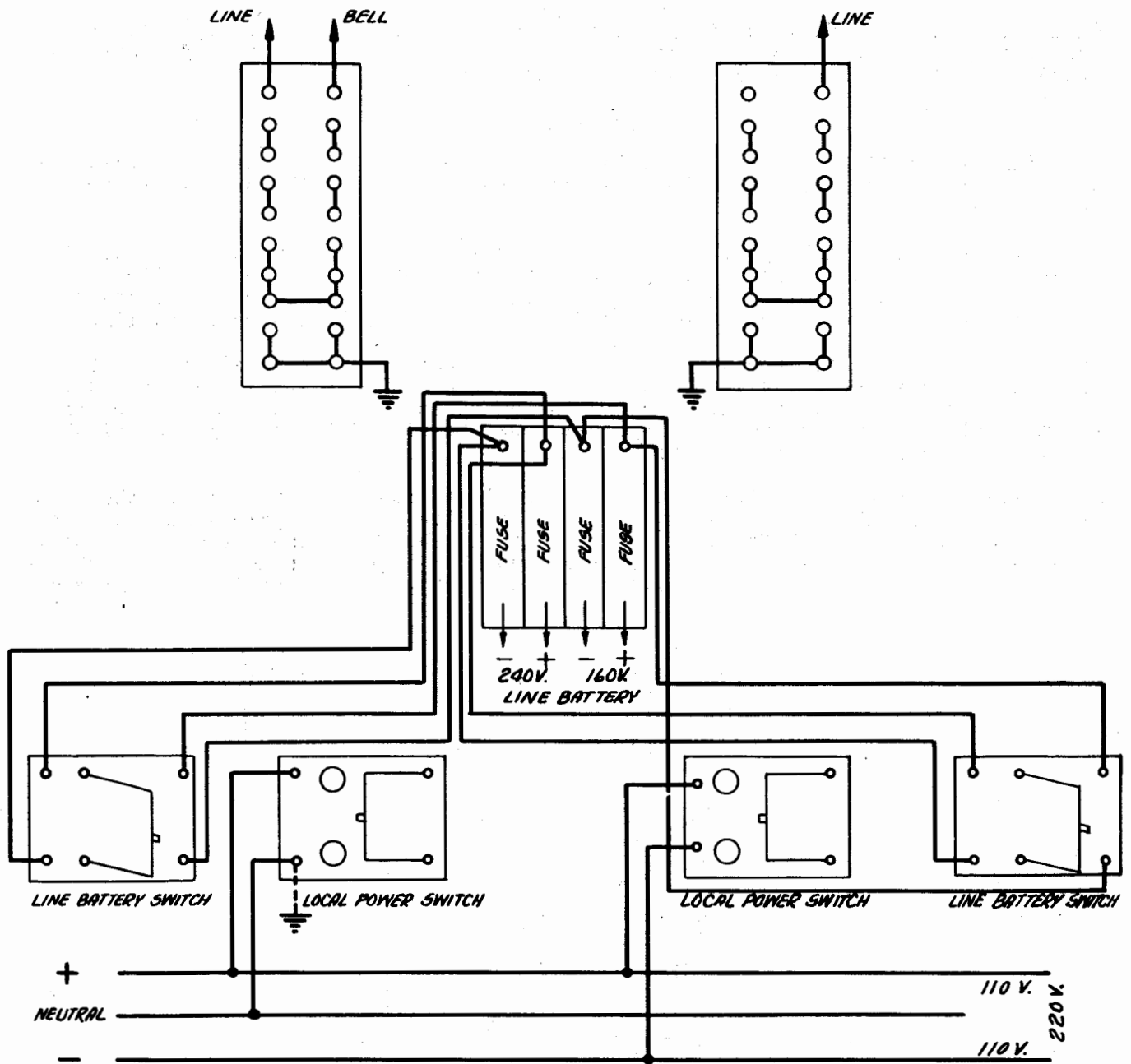

PANEL BOX CONNECTIONS  
FIGURE 12

<u>At Terminal Set</u>		<u>Word per Min. Speed</u>	<u>At Repeater Set</u>	
2	Small, 2" from stop	47	1	Small, 2" from stop
2	" 3" " "	44	1	" 3" " "
1	Large, against stop	40	2	" 1 1/4" " "
1	" 1" from stop	37	2	" 2 1/4" " "

On account of the difference in the setting of the weights at the repeater and terminal sets, to avoid misunderstanding in changing speed, the repeater attendant should be told the rate of working in words per minute.

Installation

Each repeater will be shipped completely wired and ready to be placed in position on the floor. The floor space required will be 43" x 27". The height of the table is 42".

**Local Power:** One polarity of local power supplies the different circuits of the repeater with the exception of the circuit to the contacts of the main line relays which must have both polarities. The repeaters will be shipped with resistance coil values suitable for use where the 3-wire, 110-220 volt system is available.

Referring to Figure 12, the two switches in the center of the panel box are the local power switches. The left local power switch controls the local current to all parts of the repeater which require the one polarity. It is imperative that the neutral or grounded side of the local power be placed on the terminal of the local switch which is shown as grounded.

In offices where the positive side of the local generator is grounded or where it is desirable to balance the power load, the positive grounded pole should be put on the terminal of the left local switch which is shown grounded, and the negative pole put on the other side of the local switch, but it will be necessary to change the strapping of the connecting blocks from that shown on Figure 12 to conform with Figure 13.

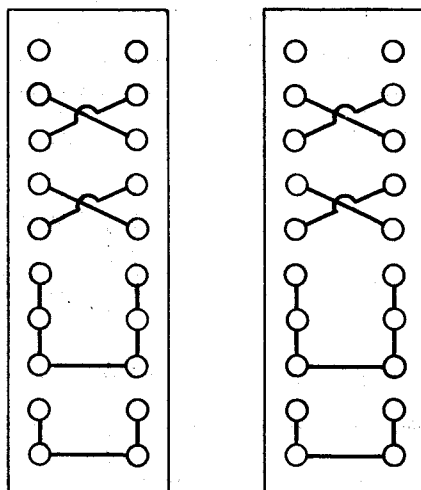
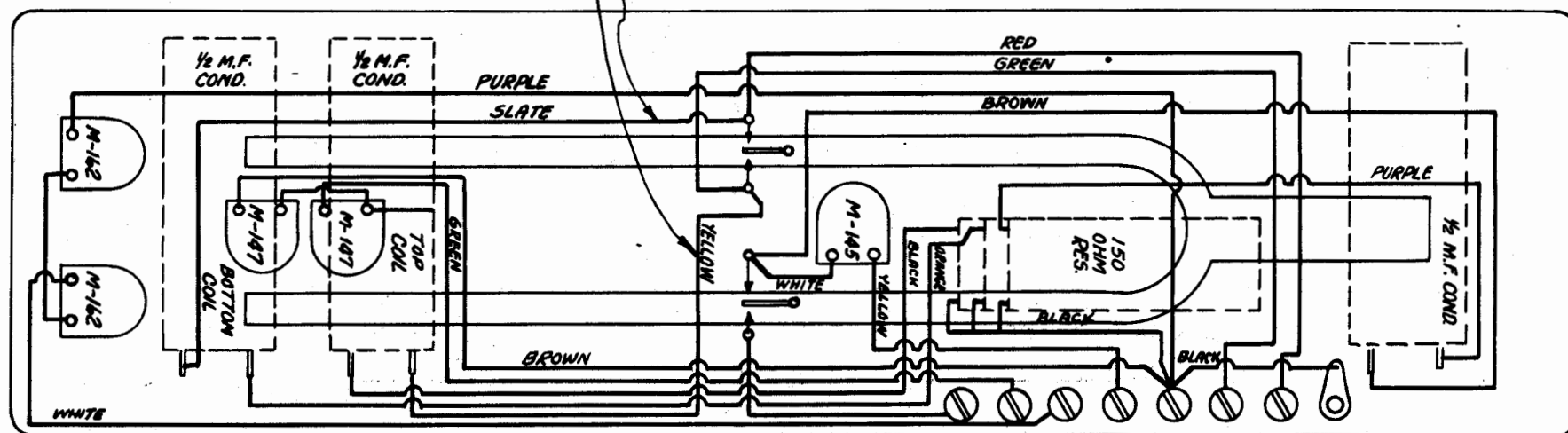

FIGURE 13

The right hand local switch controls the current to the points of the main line relays. Positive and negative 110 volts should be connected to the switch as shown. Each terminal of the right hand local switch should have a potential of 110 volts when measured to ground.

Figure 12 shows the connections to the switches where both poles of 110 volts, with grounded neutral, are used.

FOR REPEATER USE—  
DISCONNECT AND TAPE THESE WIRES



FORK WIRING  
FIGURE 14

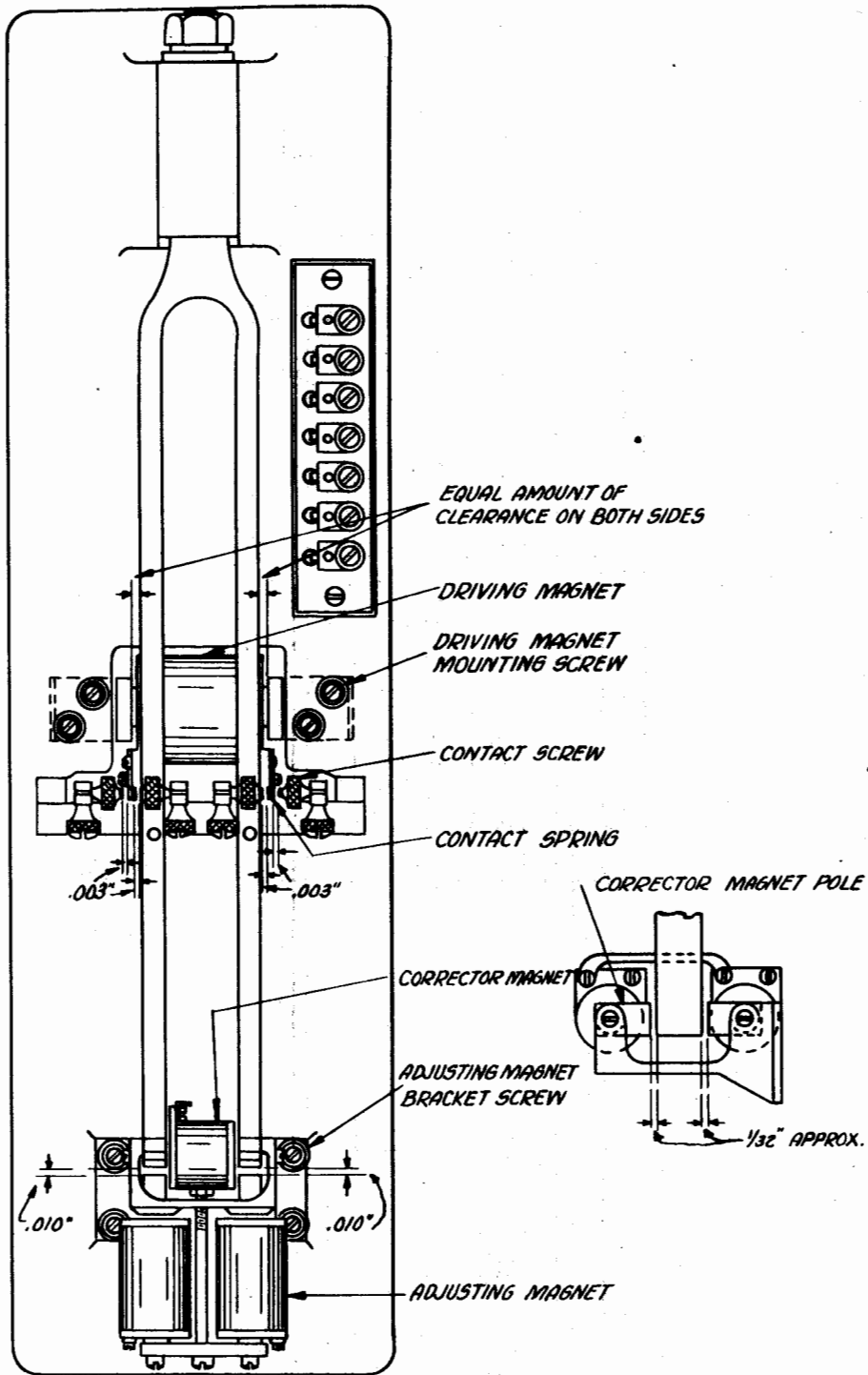

FORK ADJUSTMENTS  
 FIGURE 15

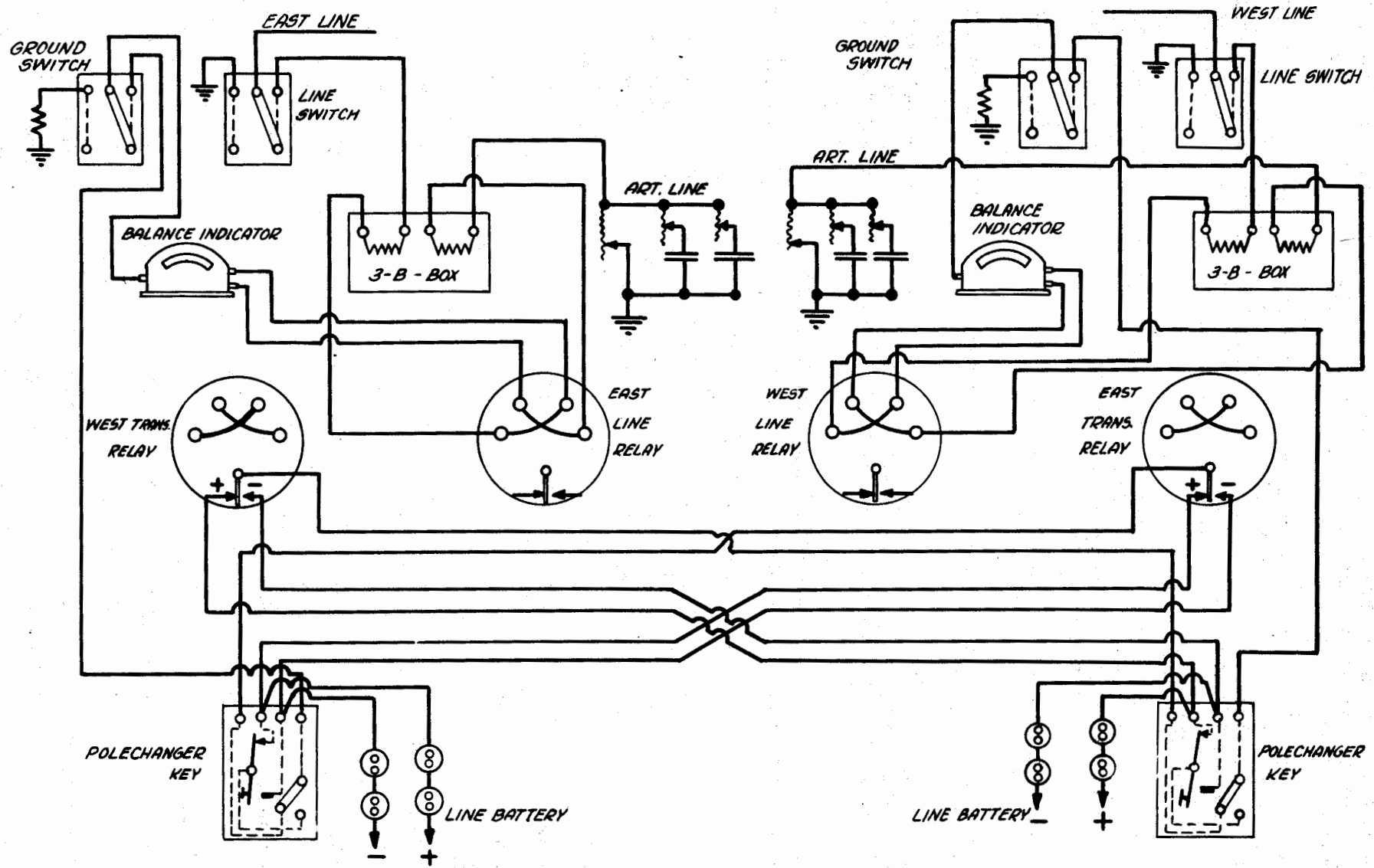

REGENERATIVE REPEATER MAIN LINE CONNECTIONS

FIGURE 16



By changing the values of the various resistances in the panel box, 160 volts may be used on either or both of the local switches. The table on this page shows the proper values of resistance to use with different voltages. Only resistances that change value are shown.

The 160 and 240 volt line battery should be connected to the fuse blocks as shown in Figure 12. The drawing also shows where the two line wires are attached to the connection blocks. The lower terminals of both connection blocks should be grounded. The terminal of the connection block marked BELL should be connected to the bell or to a one-ohm relay where a relay is used to operate the bell. If no bell is used, the terminal should be grounded.

In some European countries, positive battery is used for marking signals and negative for spacing, in which case the 160 and 240 volt line battery should be connected to the fuse blocks with polarities reversed from that shown on Figure 12. Refer to actual wiring diagram shipped with the table.

The line meter must be connected so that the needle will point to the left on an open key and to the right on a closed key.

The local meter must be connected so that the movement of the needle will coincide with that of the line meter.

The corrector meter must be wired so that the needle will point to the left when current is flowing through the corrector magnet. It is necessary that the corrector meter be properly connected in order that the instructions for checking speed will apply.

Fork Magnet Resistance Values

M-145 Driving - 225 Ohms, M-147 Corrector - 121 Ohms, M-162 Adjusting, 580 Ohms

RESISTANCE COIL VALUES

	Per rptr.	Both poles 110 v. available (Standard)	One pole 110 v. available. Use 110 v. on left local & 160 v. on right local	Both poles 160 v. available. Use on both local switches
Line Relay Contact	4	250 ohms	250 ohms	250 ohms
Locking Relay	2	3000 "	4000 "	4000 "
Reading Relay	2	4000 "	7500 "	7500 "
Switch Relay	2	4000 "	7500 "	7500 "
Corrector Relay Shunt	2	600 "	600 "	600 "
Line Relay Tongue	2	1000 "	3000 "	3000 "
Opposing Coil	2	7500 "	7500 "	7500 "
Leak	4	7500 "	7500 "	7500 "
Shunted Condenser	2	600 "	600 "	600 "
Fork Drive	2	125 "	125 "	300 "
Adjusting Rheostat	2	125 "	125 "	300 "
Holding Relay	4	4000 "	4000 "	7500 "
Corrector Coil	2	1000 "	1000 "	1500 "
Locking Relay Contact	4	1000 "	1000 "	1500 "
Bell	2	300 "	300 "	600 "
Sounder & Selector	2	1500 "	1500 "	2000 "