



BULLETIN 255B

DESCRIPTION
AND
PRINCIPLES OF OPERATION
MODEL 28
NON-TYPING REPERFORATOR
(LRPE)

TELETYPE[®]
CORPORATION
SUBSIDIARY OF *Western Electric Company* INC.
CHICAGO, ILLINOIS, U. S. A.

© 1959 by Teletype Corporation in the United States.
Copyright in all countries participating in International
Convention and Pan American Conventions. All rights
reserved including rights of translations into all
languages.

Printed in U.S.A.



LIST OF EFFECTIVE PAGES

January, 1959

PAGE	CHANGE IN EFFECT
Title Page A to C	Original Original
1-1 to 1-5 2-0 to 2-11	Original Original

The above list indicates the effective pages as of the date of issue. Upon receipt of change pages, insert them numerically and discard any superseded pages.

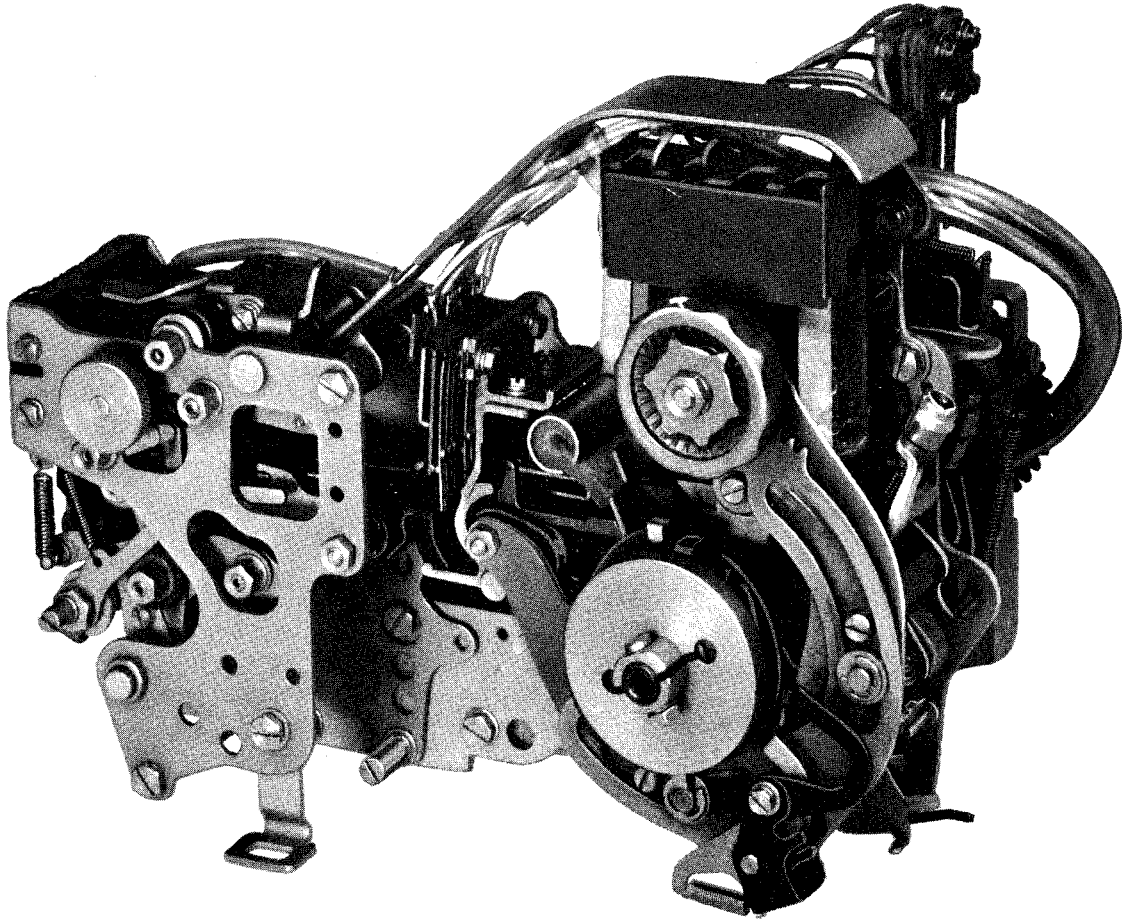

Model 28 Non-Typing Reperforator (LRPE)

TABLE OF CONTENTS

<u>Paragraph</u>	SECTION 1. DESCRIPTION	<u>Page</u>
1.	Introduction	1-1
2.	General	1-1
3.	Physical Description	1-2
	3.a. One- and Two-Cycle Units	1-2
	3.b. Two-Shaft Unit	1-3
4.	Technical Data	1-3
5.	Variable Features	1-5
	5.a. General	1-5
	5.b. Code Reading Contact Mechanism	1-5
	5.c. Timing Contact Mechanism	1-5
SECTION 2. PRINCIPLES OF OPERATION		
1.	General	2-1
2.	Code	2-1
3.	General Outline of Operation	2-3
4.	Motion	2-4
	4.a. One- and Two-Cycle Units	2-4
	4.b. Two-Shaft Unit	2-4
5.	Selection	2-4
	5.a. General	2-4
	5.b. Reception and Translation	2-4
	5.b.(1) Selecting Cam-Clutch and Trip Assembly	2-4
	5.b.(2) Clutch Operation	2-5
	5.b.(3) Selector Operation	2-7
	5.c. Two-Shaft Selection	2-8
	5.d. Orientation	2-8
6.	Motion for Perforating and Feeding	2-8
	6.a. General	2-8
	6.b. Function Cam-Clutch and Clutch Trip Assembly	2-8
	6.b.(1) One- and Two-Cycle Units	2-8
	6.b.(2) Two-Shaft Unit	2-8
	6.c. Rocker Bail	2-9
7.	Tape Perforating and Feeding	2-9
	7.a. General	2-9
	7.b. Perforating	2-11
	7.c. Feeding	2-11

LIST OF ILLUSTRATIONS

<u>Figure</u>	LIST OF ILLUSTRATIONS	<u>Page</u>
Figure 1-1	Reperforator-Transmitter Set (Photograph)	1-1
Figure 1-2	Non-Typing Reperforator Set (Photograph)	1-1
Figure 1-3	Automatic Send-Receive Keyboard with Non-Typing	1-1
	Reperforator (Photograph)	
Figure 1-4	Non-Typing Reperforator—Two-Cycle (Photograph)	1-2
Figure 1-5	Non-Typing Reperforator—Two-Cycle (Photograph)	1-3
Figure 1-6	Non-Typing Reperforator—Two-Shaft (Photograph)	1-4
Figure 1-7	Selector Magnet	1-5
Figure 2-1	Code	2-0
Figure 2-2	Block Diagram of Typical Non-Typing Reperforator	2-2
Figure 2-3	Main Shaft (One-Cycle Unit)	2-3
Figure 2-4	Shafts (Two-Shaft Unit)	2-4
Figure 2-5	Range Finder and Selecting Cam-Clutch Trip Assembly	2-5
Figure 2-6	One-Stop Clutch-Engaged	2-6
Figure 2-7	One-Stop Clutch-Disengaged	2-6
Figure 2-8	Two-Stop Clutch-Disengaged	2-6
Figure 2-9	Selector	2-7
Figure 2-10	Function Cam-Clutch and Clutch Trip Assembly	2-9
Figure 2-11	Perforating Mechanism	2-10

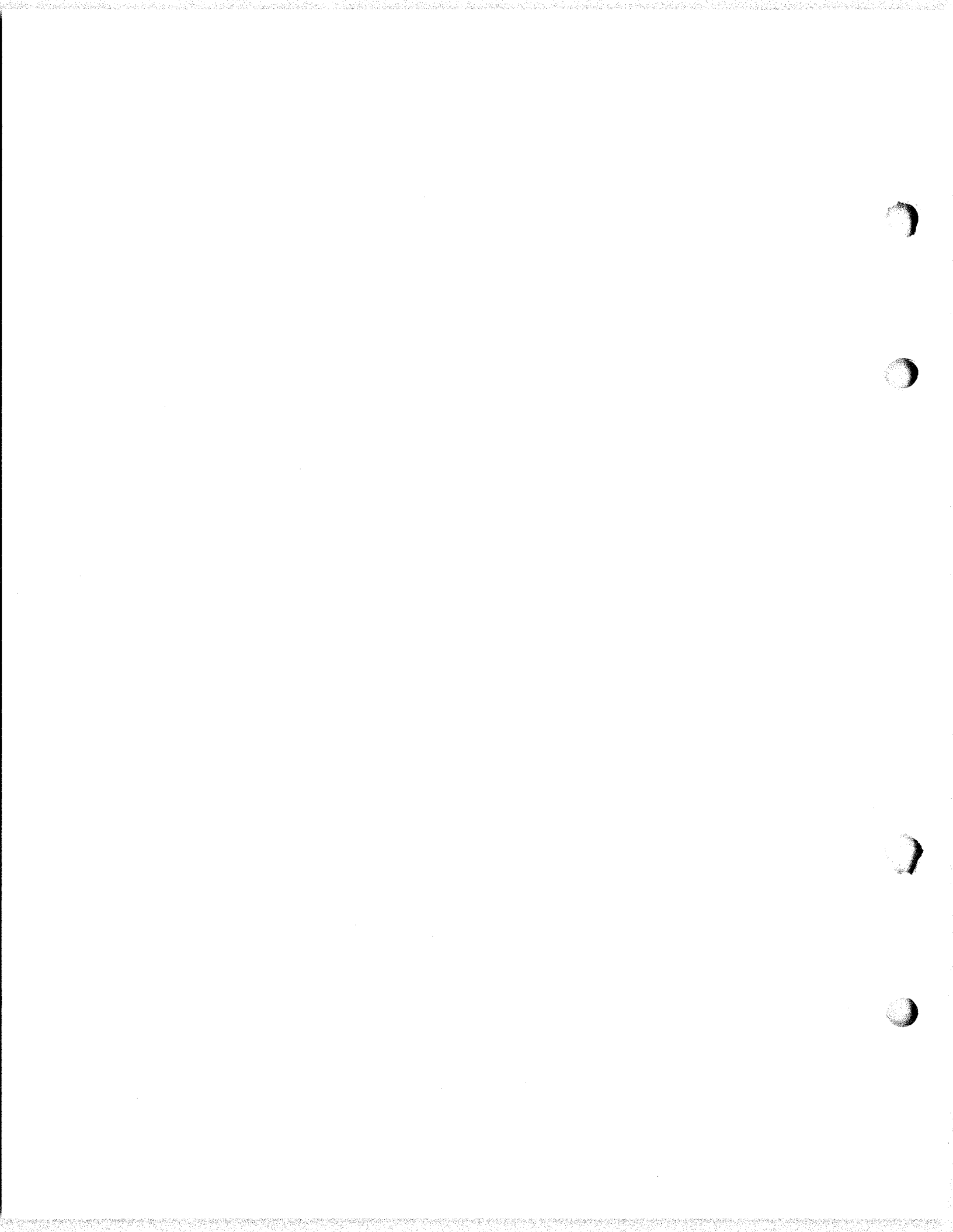

SECTION 1

DESCRIPTION

1. INTRODUCTION

1.a. This bulletin describes and explains the operation of the Teletype Model 28 Non-Typing Reperforator. Section 1 presents a physical description of the equipment and provides a summary of its technical data. Section 2 covers in detail its principles of operation.

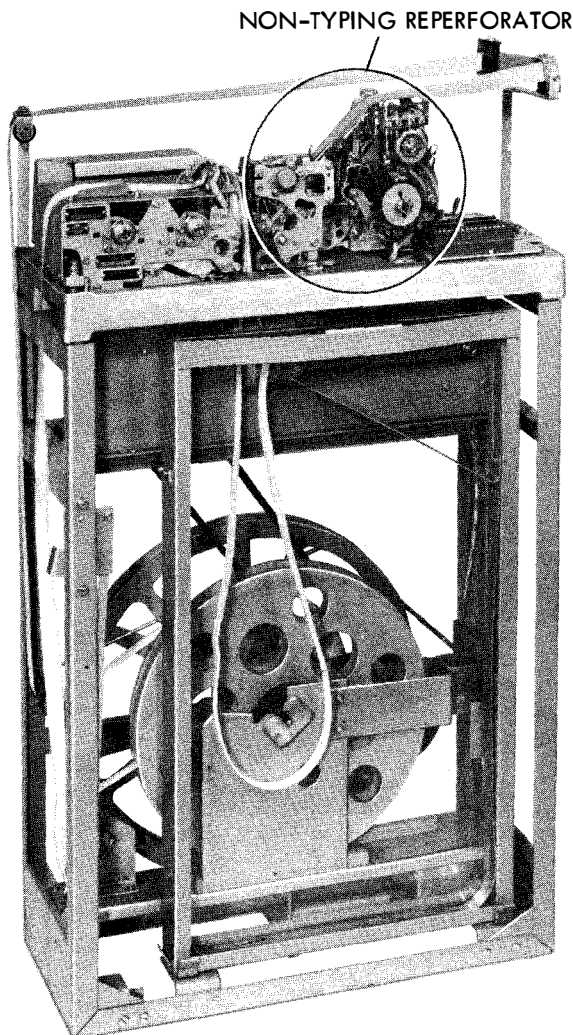

Figure 1-1. Reperforator - Transmitter Set

1.b. Unless stated to the contrary, references in the text to "left" or "right" indicate the viewer's left or right as he faces the front of the unit. In the illustrations, unless they are specifically labeled otherwise, it is assumed that the equipment is being viewed from the front. Pivot points are shown in the drawings by

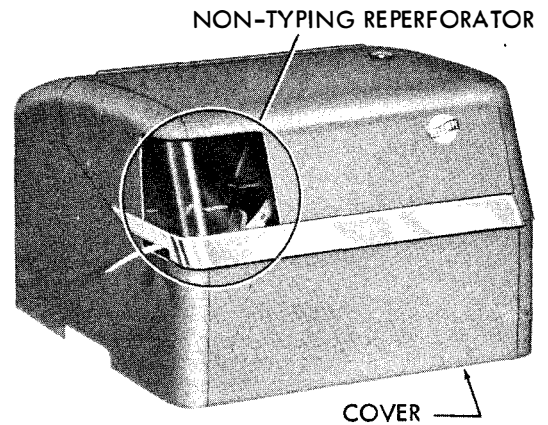

Figure 1-2. Non-Typing Reperforator Set

circles or ellipses which are solid black to indicate fixed points and crosshatched to indicate floating points.

2. GENERAL

2.a. The Model 28 Non-Typing Reperforator is an electro-mechanical unit which records information in tape as combinations of chadless code holes. The information is received from a signal line in the form of an electrical signaling code which is translated into the necessary mechanical motions to perforate the code holes and feed the tape. Motive power must be provided by an external source; e.g., by a motor unit and drive mechanism.

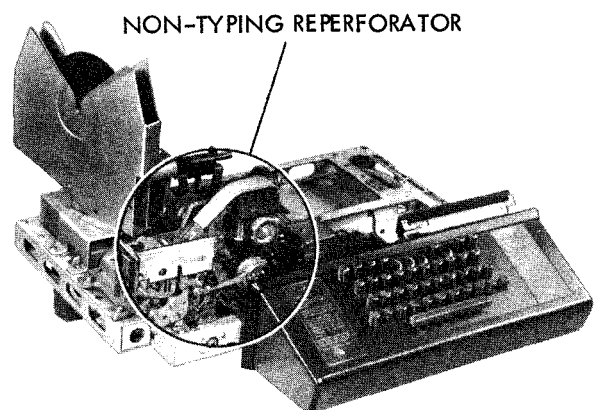

Figure 1-3. Automatic Send-Receive Keyboard with Non-Typing Reperforator

2.b. The unit may be used with various other Teletype apparatus in applications related to the recording and storing of information in tape. It is a basic component of the Non-Typing Reperforator Set (Figure 1-2) which, at a minimum, includes a base, a motor unit and a drive mechanism and which, in addition, may also embrace a cover, a table and an electrical service unit. The other units mentioned above are covered in Teletype Bulletin 246B. The Reperforator may be a component of the Reperforator-Transmitter Set (Figure 1-1) and the Automatic Send-Receive Set (see Figure 1-3 and Bulletin 249B). The model used in the latter application will function as a tape perforator (operated mechanically from a keyboard) or as a reperforator (operated by the signal pulses). A number of Reperforators may be gang mounted for multiple operation.

2.c. The unit will operate on a d.c. signal line current of 0.060 or 0.020 ampere. It accommodates standard-width tape and produces five-level, chadless code perforations; i.e., the per-

forated portions (chads) are not completely severed but remain attached at their leading edges. Thus tape clogging and chad disposal is eliminated. Speeds up to approximately 200 words per minute are available in the different variations of the unit.

3. PHYSICAL DESCRIPTION

3.a. ONE- AND TWO-CYCLE UNITS (Figures 1-4 and 1-5) — A cast frame provides mounting facilities for the various mechanisms which comprise the Non-Typing Reperforator. Rotary motion from an external source is received by a main shaft and distributed by two cam-clutches. A selecting mechanism, which includes a two-coil magnet wired to the signal line, converts the electrical code combinations into mechanical arrangements which govern perforating. The coils may be wired in series for 0.020-0.030 ampere operation or in parallel for 0.060 ampere operation (see Figure 1-7). By means of a range finder the selecting mechanism can be

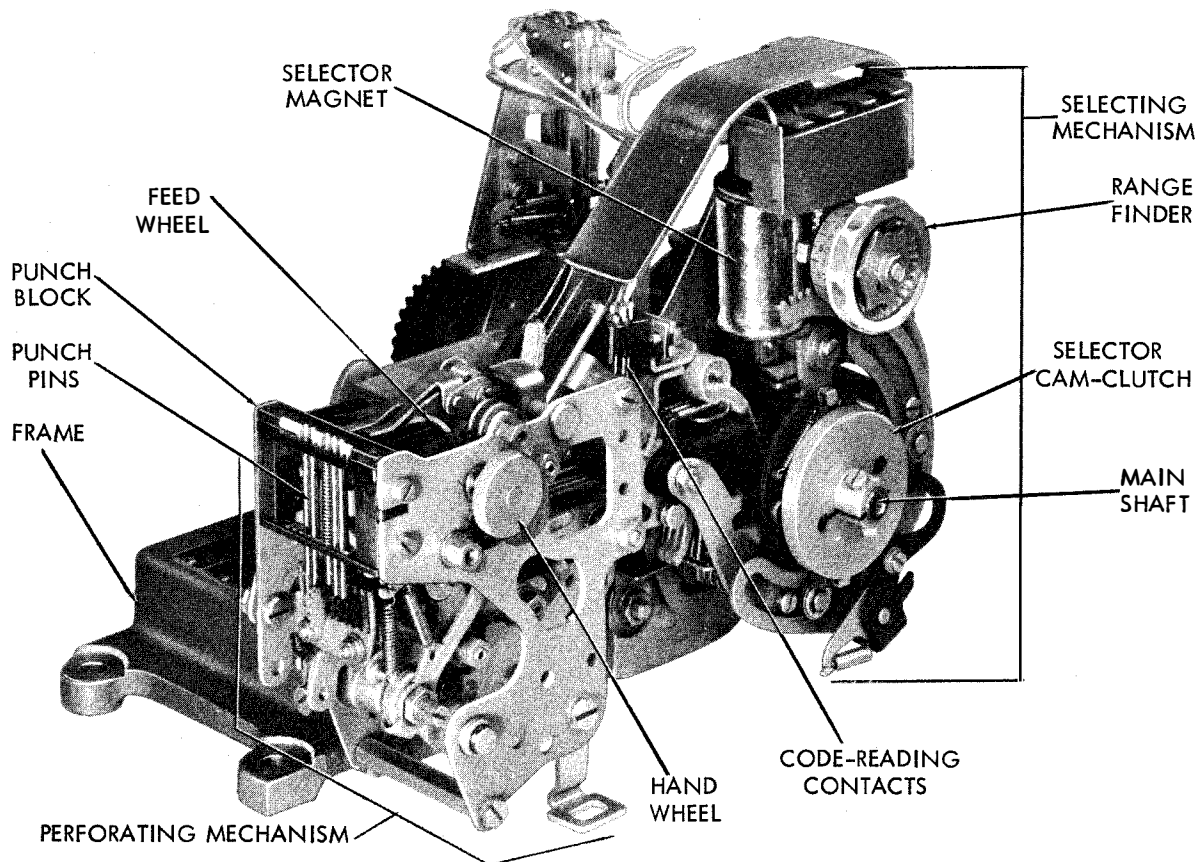

Figure 1-4. Non-Typing Reperforator - Two-Cycle

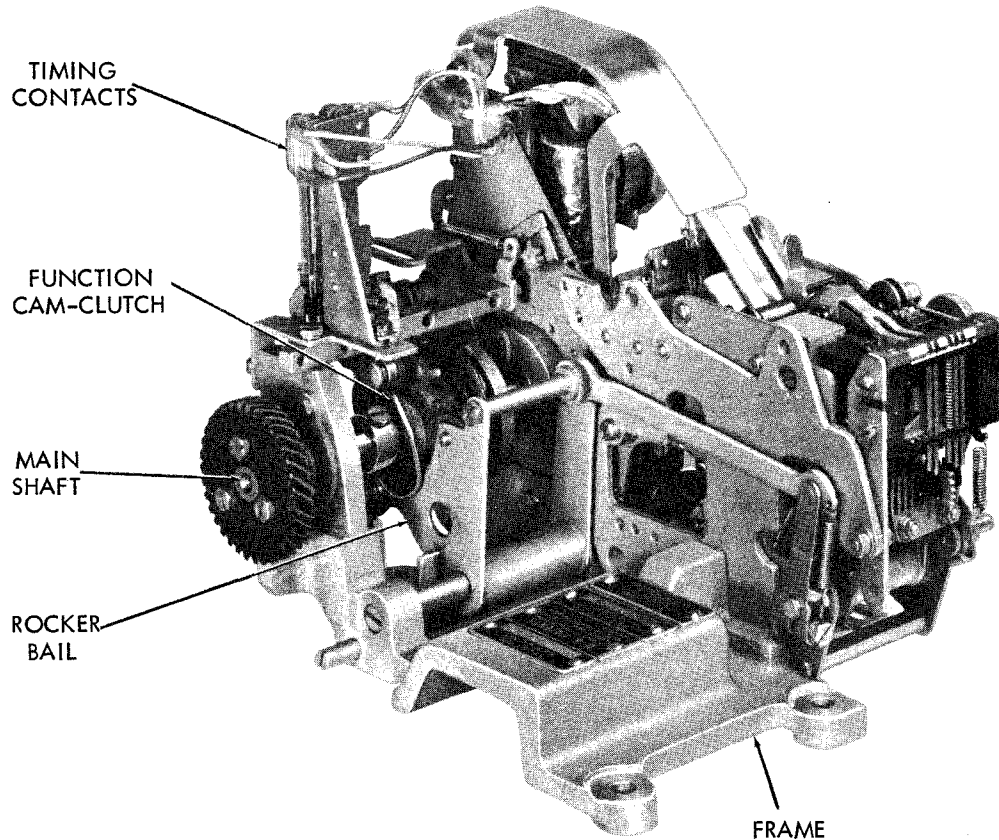

Figure 1-5. Non-Typing Reperforator - Two-Cycle

adjusted in relation to the signaling code. A rocker bail transfers motion from the main shaft to a perforating mechanism. A feed wheel and a die wheel roll in feed holes and advance the tape. The code holes are perforated in a punch block by punch pins. The tape may be threaded and manually advanced by a hand wheel. The one- and two-cycle units are essentially the same except that the cam-clutches of the two-cycle unit complete their cycle during 180 degrees of shaft rotation rather than 360 degrees as do those of the one-cycle unit. The maximum speed of the one-cycle unit is approximately 100 words per minute while that of the two-cycle unit is approximately 200 words per minute.

3.b. TWO-SHAFT UNIT (Figure 1-6) — The two-shaft Reperforator is designed to be mounted on the automatic send-recv keyboard (see Figure 1-3 and Bulletin 249B). It may be operated either from signal pulses or by direct mechanical action from the keys of keyboard. It differs from the other units (see paragraph 3.a. above) primarily in the method of driving the cam-clutches. An extra shaft, the jack shaft, enables the perforating mechanism to be operated at a different speed from that of the selec-

ting mechanism. Thus the speed of the selecting mechanism may be adjusted to line conditions (up to approximately 100 words per minute), while the speed of the perforating mechanism remains constant. An optional feature is a back-space mechanism which will permit substitution of a letters combination for an erroneously perforated character (see Bulletin 249B).

4. TECHNICAL DATA

APPROXIMATE DIMENSIONS AND WEIGHT (TYPICAL UNIT)

Width	7-1/2 inches
Depth	6-1/2 inches
Height	6 inches
Weight	5-1/2 pounds

SIGNALING CODE . . . Sequential, five-unit, start-stop. (See Figure 2-1 and Subdivision 2. of Section 2.)

LINE CURRENT

Up to 100 wpm.	0.060 or 0.020 ampere
200 wpm.	0.060 ampere

SPEED*

Approx. Words/Min.	Operations/Min.	Baud	Frequency (Cycles/Sec.)	Pulse Length (Sec.)	Characters/Sec.
60	368	45.5	22.75	0.0220	6.0
67	404	50.0	25.00	0.0200	6.7
75	460	56.9	28.45	0.0175	7.7
100	600	74.2	37.10	0.0135	10.0
200	1200	148.4	74.20	0.0067	20.0

*Data based on 7.42 unit code transmission pattern.
Other speeds are available. See Subdivision 2. of Section 2.

TAPE Standard
 Width 11/16 inch
 Code Perforations Five-level chadless
 Code combinations or feed holes/inch 10
 Feed holes and code holes are in line.

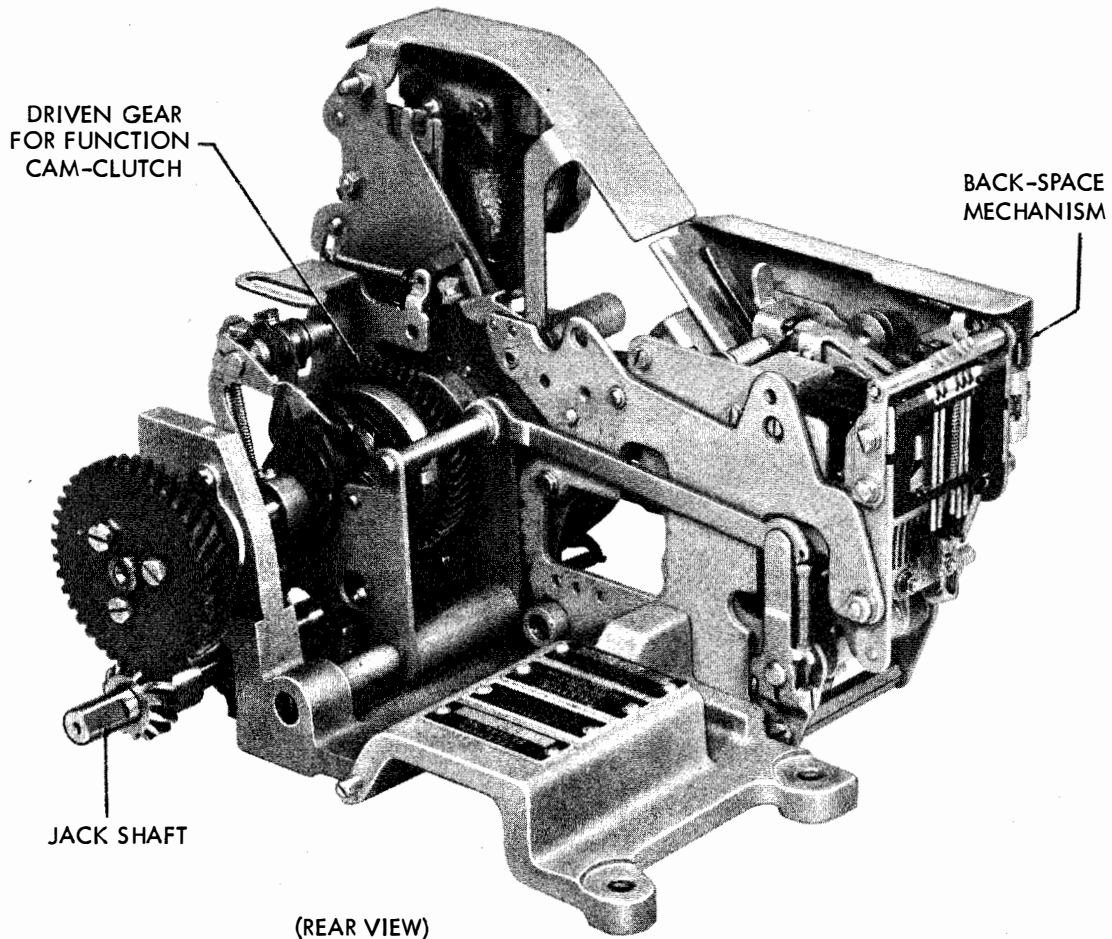

Figure 1-6. Non-Typing Reperforator - Two-Shaft

5. VARIABLE FEATURES

5.a. GENERAL — The variable features described below are available with the Non-Typing Reperforator. These features enable the unit to perform special operations and may be installed either at the factory or in the field.

5.b. CODE-READING CONTACT MECHANISM (Figure 1-4) — Reads the code combinations being perforated by the unit and establishes circuits corresponding to the five code elements. The mechanism consists of a bank of five wetting contacts (i.e., contacts which do not make or break current), each of which is actuated by a punch slide. Either transfer (break-before-make) or make contacts are available. The contacts are capable of carrying approximately 0.060 ampere at 110 volts d.c. and may be adjusted to meet various timing requirements. Applications include error checking and parallel code output.

5.c. TIMING CONTACT MECHANISM (Figure 1-5) — Incorporates contacts which are actuated at a predetermined time during each operation of the Reperforator. The contacts, which can be adjusted to meet various timing requirements, may be connected to external circuits for control purposes; e.g., they may be used to open and close the circuits established by the code reading contacts (paragraph 5.b. above). A single-contact mechanism (incorporating one transfer contact) and a double-contact mechanism (incorporating two transfer contacts) are available. The contacts are mounted by brackets on the rear of the frame and are actuated by the function cam. The maximum recommended breaking current is 0.100 ampere at 110 volts d.c. in a non-inductive circuit.

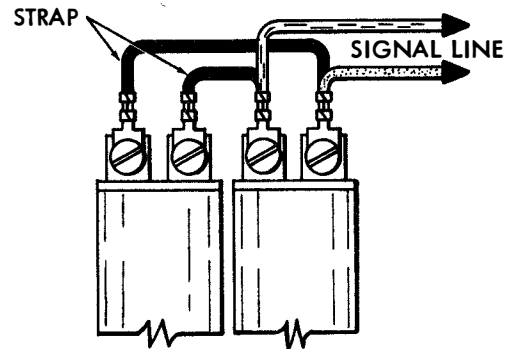

COILS IN PARALLEL FOR 0.060 AMPERE OPERATION

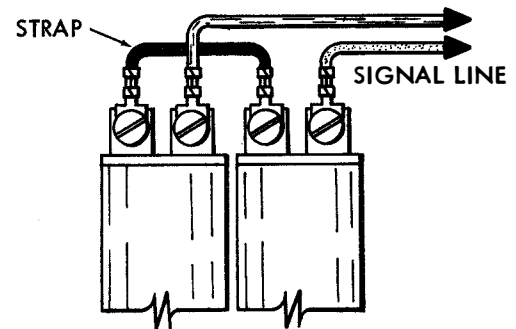

COILS IN SERIES FOR 0.020 — 0.030 AMPERE OPERATION

Figure 1-7. Selector Magnet

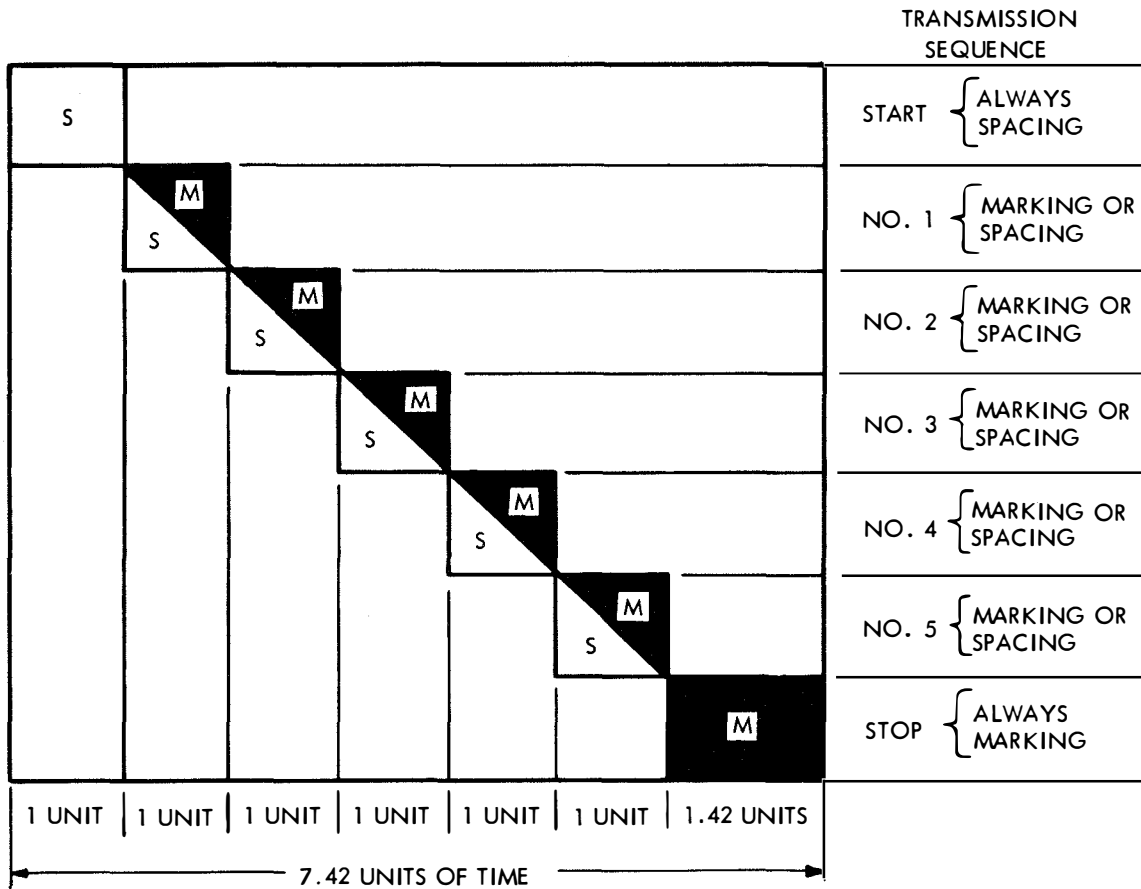

a. SIGNALING CODE

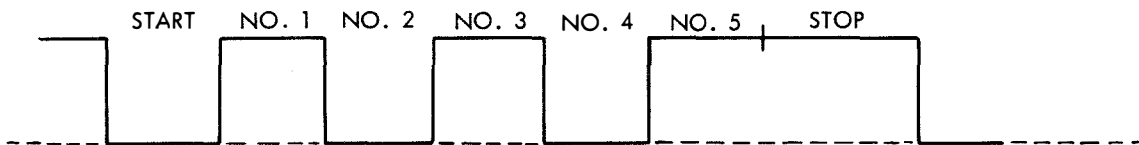

b. GRAPHIC REPRESENTATION OF LETTER "Y"

FIGURES	-	?	:	\$	3	!	a	#	8	'	()	.	,	9	0	1	4	0	5	7	;	2	/	6	"	2	<	≡	■	v	^		
LETTERS	A	B	C	D	E	F	G	H	I	J	K	L	M	N	O	P	Q	R	S	T	U	V	W	X	Y	Z	BLANK	C.R.	L.F.	SPACE	LTR.	FIG.		
1	○	○		○	○	○				○	○					○	○			○	○	○	○	○	○							○	○	
2	○	○		○	○	○				○	○					○	○			○	○	○	○	○	○								○	○
FEED HOLES	○	○	○	○	○	○	○	○	○	○	○	○	○	○	○	○	○	○	○	○	○	○	○	○	○	○	○	○	○	○	○	○	○	○
3			○			○	○	○	○	○	○			○	○	○	○	○	○	○	○	○	○	○	○	○							○	○
4		○	○	○		○	○			○	○	○	○	○	○	○				○			○	○									○	○
5		○				○	○			○	○	○	○	○	○					○	○	○	○	○	○								○	○

c. CODE HOLE COMBINATIONS OF TYPICAL CHARACTER ARRANGEMENT

Figure 2-1. Code

SECTION 2
PRINCIPLES OF OPERATION

1. GENERAL

1.a. This section explains the operation of the Model 28 Non-Typing Reperforator. The basic function of this unit is to record information in paper tape as chadless code perforations. The information is received from a signal line in the form of signaling code combinations which represent characters or functions. The Reperforator translates these combinations into mechanical motions which roll in feedholes, advance the tape and perforate corresponding combinations of code holes.

1.b. Functions are operations auxiliary to typing (such as "carriage return," "space," "letters," "figures," etc.) which are perforated into the tape so that it can be used in conjunction with typing equipment. The Reperforator is referred to as being in the idling condition when the main shaft is turning, the signal circuit is closed and no message is being received. The speed of the equipment is usually given in operations per minute. Each operation includes the receiving of a code combination, the cycling of the two cam-clutches, the perforating of a character and the advancing of the tape.

2. SIGNALING CODE (Figure 2-1)

2.a. Information is received by the Non-Typing Reperforator in the form of a five-unit, start-stop signaling code in which each character or function is represented by a sequential combination of current and no-current time intervals. Intervals during which current flows in the signal circuit are referred to as marking elements and during which no current flows as spacing elements. Every combination includes five elements that carry the intelligence, each of which may be either marking or spacing as illustrated in Figure 2-1a. The intelligence elements are preceded by a start element (always spacing) and are followed by a stop element (always marking) which is 1.42 times as long as each of the

other elements. Thus each combination consists of 7.42 units of time (referred to as a 7.42 unit transmission pattern). The start and stop elements ensure synchronism between the transmitting and receiving equipment by bringing the receiving equipment to a complete stop at the end of each combination. The letter "Y", plotted in Figure 2-1b., is usually used for testing and illustrating purposes because each of its alternate intelligence elements is different.

2.b. The total number of permutations of a five-unit code is two to fifth power, or 32. In order to transmit more than 32 characters and functions, a letters-figures shift operation is designed into the typing equipment. Thus each permutation, excluding those used to shift and unshift the apparatus, may represent two characters or functions.

2.c. Only the intelligence elements of the code appear in the perforated tape. The marking pulses are represented by holes and the spacing pulses by the absence of holes. The various code combinations of a typical character arrangement, as they appear in tape form, are shown in Figure 2-1c.

2.d. Some telegraph systems employ a 7.00 unit transmission pattern in which the stop element is equal to each of the other elements (see paragraph 2.a. above). Interoperation between 7.42 and 7.00 apparatus is satisfactory providing the operating speeds selected yield identical unit pulse lengths. The signaling frequency is expressed in maximum dot cycles per second. One cycle consists of one current pulse followed by a no-current pulse. The equipment speed in baud (common in international usage) is equal to twice the frequency. The following chart shows the relationships between the transmission patterns, frequency, pulse lengths and operating speed (in operations per minute, baud and characters per second). Speed in words per minute is roughly equivalent to one sixth the operations per minute.

Transmission Pattern	7.42	7.00	7.42	7.00	7.42	7.42	7.00
Operations Per Minute	368	390	404	428.6	460	600	636
Baud	45.5	45.5	50	50	56.9	74.2	74.2
Pulse Length (seconds)	.022	.022	.020	.020	.0175	.0135	.0135
Frequency (Cycles per Second)	22.75	22.75	25	25	28.45	37.1	37.1
Characters per Second	6	6.5	6.7	7.1	7.7	10	10.6

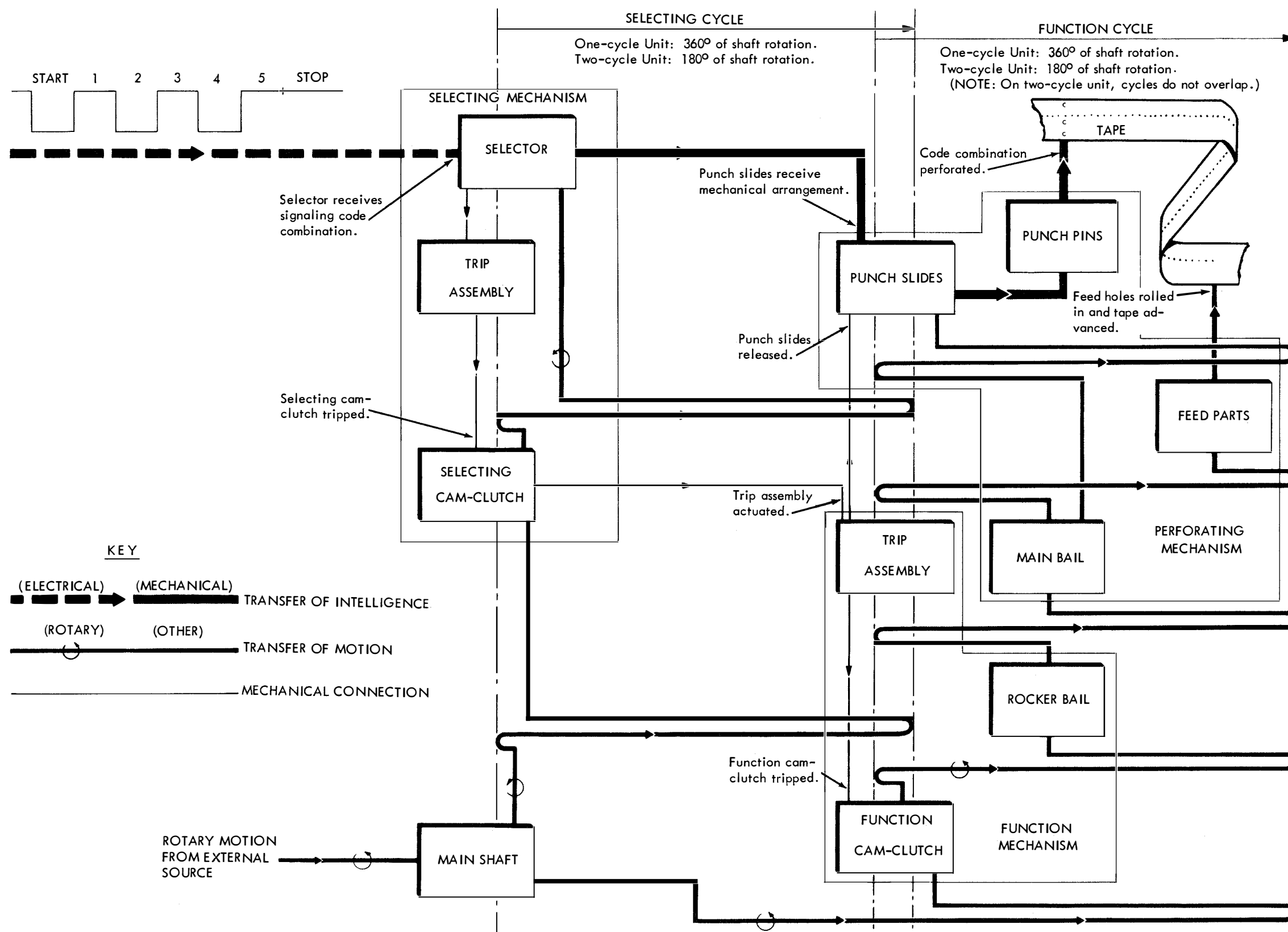

Figure 2-2. Block Diagram of Typical Non-Typing Rep perforator

3. GENERAL OUTLINE OF OPERATION (Figure 2-2)

3.a. The relationship of the different mechanisms and the approximate timing of an operation are illustrated in the block diagram of Figure 2-2. Rotary motion from an external source is received by the main shaft which turns continuously as long as the unit is under power.

3.b. The signaling code combinations—e.g., the combination representing the letter "Y" plotted at the left of Figure 2-2—are applied to the selecting mechanism. The start pulse of each code combination causes the selector, through a trip assembly, to trip the selecting cam-clutch. The main shaft then imparts motion to the cam-clutch throughout the selecting cycle. The cam-clutch, in turn, transfers timed motion to the selector which converts the intelligence elements of the code combination into a corresponding mechanical arrangement. Near the end of the selecting cycle, the cam-clutch actuates the function trip assembly. The latter trips the function cam-clutch and releases the punch slides of the perforating mechanism so that they

can receive the code arrangement from the selector. The selecting cam-clutch is then disengaged and remains inoperative until the next code combination is received.

3.c. The function cam-clutch, driven by the main shaft, imparts motion to the rocker bail throughout the function cycle. The rocker bail transfers the motion to the perforator main bail which, in turn, distributes it to the punch slides and the tape feed parts. The punch slides, having received the arrangement from the selector, cause the punch pins to perforate code holes in the tape corresponding to the code pulses received by the selecting mechanism. Late in the function cycle, the tape feed parts roll in feed holes and advance the tape. The function cam-clutch is then disengaged and remains stationary until again tripped by the selecting cam-clutch. The operations of the Reperforator may overlap if the code combinations are being received fast enough. For example, while the perforating mechanism is punching the code combination and advancing the tape, the selecting mechanism may be processing the next code combination.

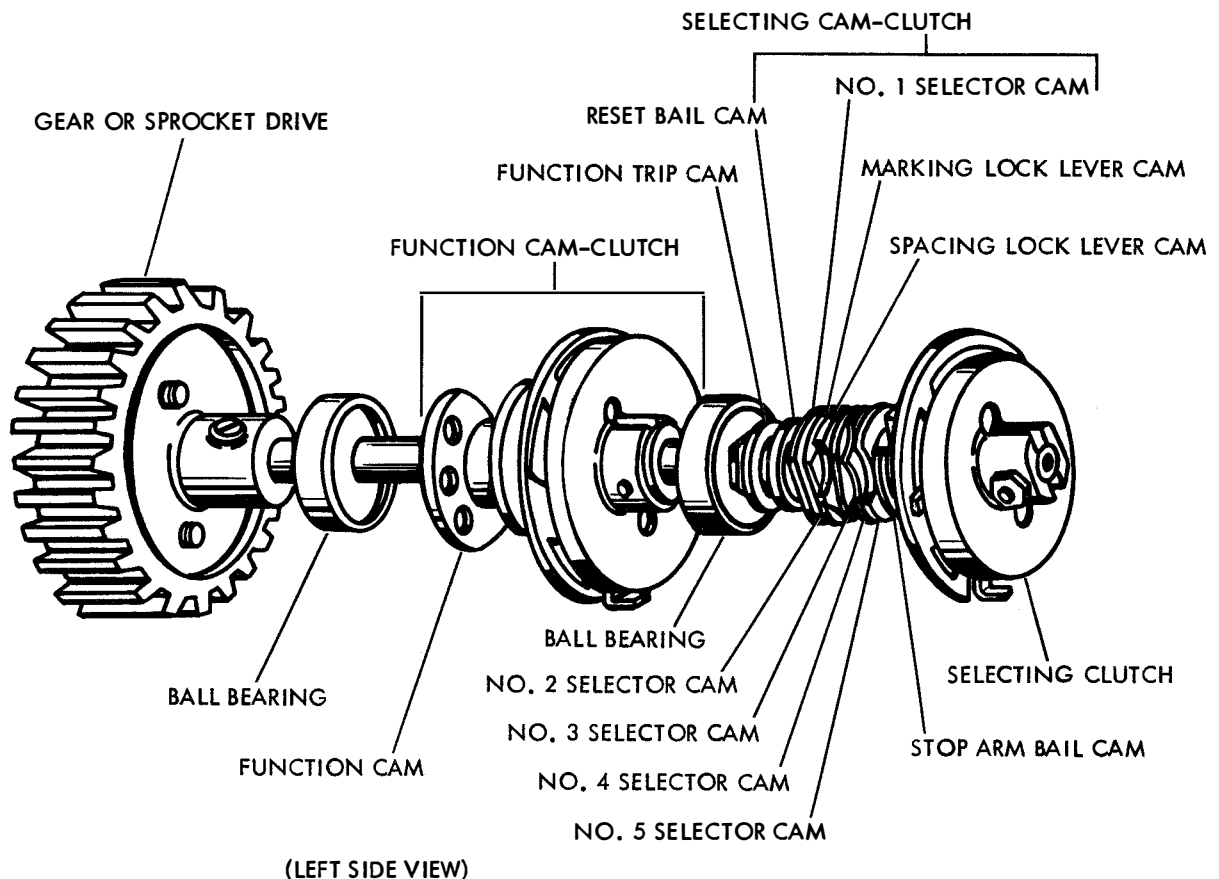

Figure 2-3. Main Shaft (One-Cycle Unit)

4. MOTION

4.a. ONE- AND TWO-CYCLE UNITS (Figure 2-3) — Rotary motion from an external source is received by the main shaft which rotates continuously as long as the unit is under power. Selecting and function cam-clutches distribute this motion to the selecting and function mechanisms as described in paragraphs 5.b(1) and 6.b. below.

4.b. TWO-SHAFT UNIT (Figure 2-4) — The jack shaft of the two-shaft reperforator unit is coupled directly to the driving shaft of the automatic send-receive keyboard (see Bulletin 249B). A set of gears at the rear of the unit, which may be replaced to obtain different selecting speeds, transfers motion from the jack shaft to the main shaft. Another set of gears, positioned toward the ends of the shafts, convey motion from the jack shaft to the drum of the function cam-clutch

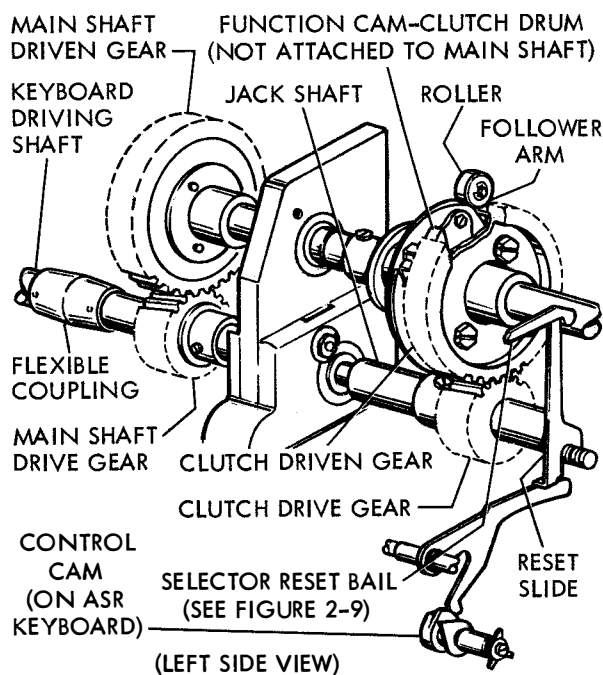

Figure 2-4. Shafts (Two-Shaft Unit)

which, in contrast to the other units, is not attached to the main shaft. Thus the selecting cam-clutch and the function cam-clutch can rotate at different speeds. The main shaft and the drum of the function cam-clutch rotate continuously as long as the unit is under power.

5. SELECTION

5.a. GENERAL — The selecting mechanism—made up of a selector (Figure 2-9), a clutch trip assembly (Figure 2-5) and a cam-clutch (Figure 2-3)—translates the signaling code combinations into mechanical arrangements which govern the

perforation of the tape. The electrical pulses comprising each code combination are applied to a magnet of the selector. The magnet through an armature controls the clutch trip assembly and the parts associated with translation. The cam-clutch transfers timed motion to the selector and also trips the function cam-clutch. By means of a range finder assembly (Figure 2-5), the selecting mechanism can be adjusted to sample the code elements at the most favorable time for optimum operation. The mechanical arrangements produced by the selecting mechanism are passed on to the punch slides which control the perforating mechanism (Figure 2-11). In the case of the two-cycle unit, selection is essentially the same as that of the one-cycle unit, except that the selecting mechanism is designed to operate during one-half, rather than one complete revolution of the main shaft. The two shaft unit is covered in paragraph 5.c. below.

5.b. RECEPTION AND TRANSLATION

5.b.(1) Selecting Cam Clutch and Trip Assembly (Figures 2-3 and 2-5).

5.b.(1)(a) The selecting cam-clutch includes (from right to left in Figure 2-3) the clutch, the stop arm bail cam, the fifth, the fourth and the third selector cams, the cams for the spacing and the marking lock levers, the second and the first selector cams, the selector reset bail cam and the function trip cam. During the time in which the signal circuit is closed (marking), the selector magnet coils are energized and hold the selector armature up against the magnet pole pieces (Figure 2-5). In this position, the armature blocks the start lever, and the cam clutch is held stationary between the stop arm and latch lever.

5.b.(1)(b) When a code combination is received, the start (spacing) element de-energizes the magnet, and the selector armature under tension of its spring moves down out of the way of the start lever. The start lever turns clockwise under spring pressure and moves the stop arm bail into the indent of its cam (Figure 2-5). As the stop arm bail rotates about its pivot point, the attached stop arm is moved out of engagement with the clutch shoe lever. The selecting cam-clutch engages and begins to rotate counterclockwise. The stop arm bail immediately rides to the high part of its cam where it remains to hold the start lever away from the armature while the intelligence elements of the code are received and processed by the selector (paragraph 5.b.(3) below).

5.b.(1)(c) When the stop element at the end of the code combination is received, the armature is pulled up and blocks the start lever. Thus the stop arm bail is prevented from dropping onto the low part of its cam, and the attached

stop arm is held in position to stop the clutch shoe lever. When the clutch shoe lever strikes the stop arm, the inertia of a cam disk causes it to continue to turn until its lug makes contact with the clutch shoe lever. At this point a latch lever drops into an indent in the cam disk, and the clutch is held disengaged until the next code combination is received.

5.b.(2) Clutch Operation (Figures 2-6, 2-7 and 2-8).

5.b.(2)(a) The operation of the one-stop clutch is covered in paragraphs 5.b.(2)(b) and 5.b.(2)(c). How the functioning of the two-stop clutch differs is set forth in paragraph 5.b.(2)(d).

5.b.(2)(b) The clutch drum is attached to

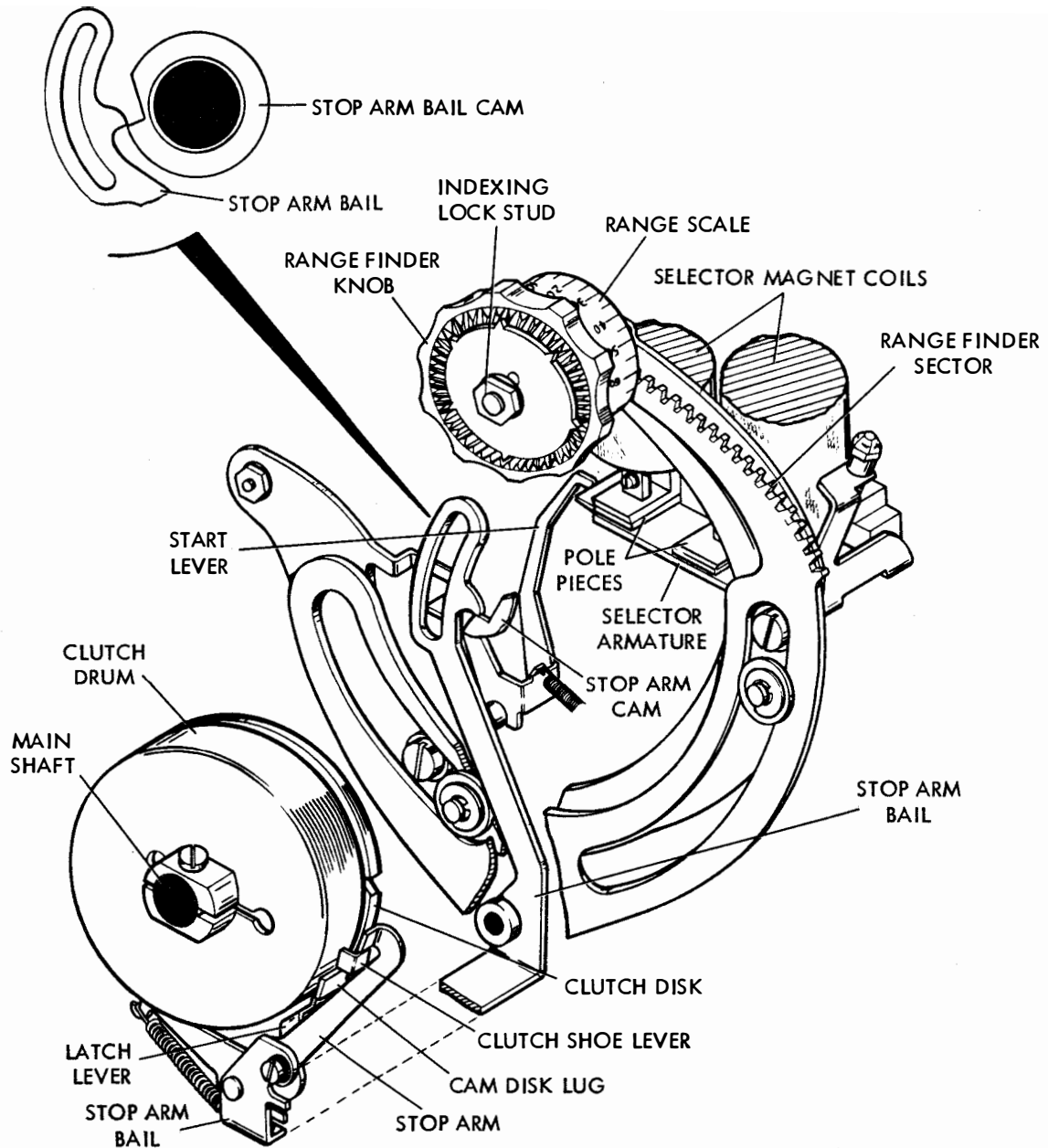

Figure 2-5. Range Finder and Selecting Cam-Clutch Trip Assembly

and rotates in unison with the main shaft (Figure 2-5). In the disengaged position, as shown in Figure 2-7, the clutch shoes do not contact the drum, and the shoes and cam disk are held stationary. Engagement is accomplished by moving the stop arm (Figure 2-5) away from the clutch and thus releasing stop lug A and the lower end of shoe lever B (Figure 2-6). The upper end of lever B pivots about its ear C, which bears against the upper end of the secondary shoe, and moves its ear D and the upper end of the primary shoe toward the left until the shoe makes contact with the drum at point E. As the drum turns counterclockwise, it drives the primary shoe downward so that it again makes contact with the drum at point F. There, the combined forces acting on the primary shoe cause it to push against the secondary shoe at point G. The lower end of the secondary shoe then bears against the drum at point H. The drum drives this shoe upward so that it again makes contact with the drum at point I. The forces involved are multiplied at

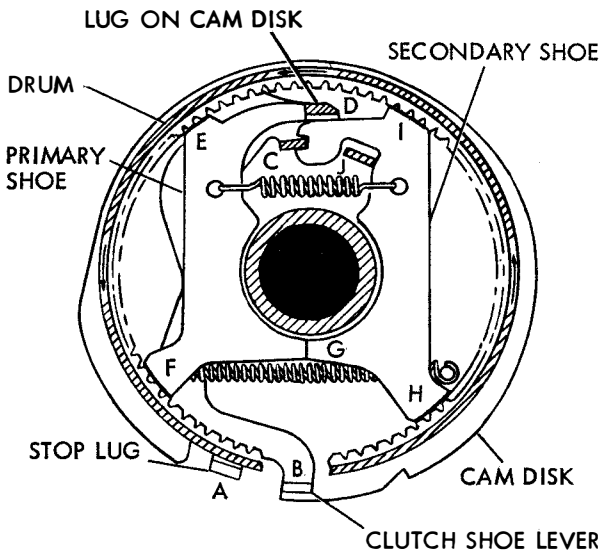

Figure 2-6. One-Stop Clutch-Engaged

each of the preceding steps. The aggregate force is applied through the shoes to the lug J on the clutch cam disk, and the disk and attached cam turn in unison with the drum.

5.b.(2)(c) Disengagement is effected when the lower end of shoe lever B strikes the stop arm (see Figure 2-5). Lug A and the lower end of the shoe lever are brought together (Figure 2-7), and the upper end of lever B pivots about its ear C and allows its other ear D to move toward the right. The upper spring then pulls the two shoes together and away from the drum. The latch lever seats in the indent in the cam disk (paragraph 5.b.(1)(c)) and the cam is held in its stop position until the clutch is again engaged.

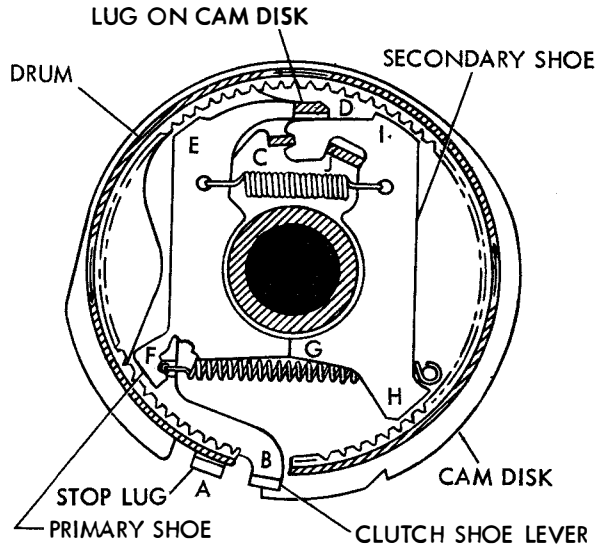

Figure 2-7. One-Stop Clutch-Disengaged

5.b.(2)(d) The operation of the two-stop clutch, which is used exclusively on the two-cycle unit and on the function cam-clutch of the two-shaft unit, is similar to that of the one stop clutch, the major difference being that it can be stopped after 180 degrees of rotation rather than 360 degrees. The two-stop clutch is shown disengaged in Figure 2-8. When the stop arm is moved away from A, the shoe lever disk under spring tension pivots counterclockwise and carries with it the shoe lever which engages the shoe lever disk at B. The shoe lever moves the primary shoe to the left and engagement is completed as described in paragraph 5.b.(2)(b) above. After the cam-clutch rotates 180 degrees, the shoe lever disk strikes the stop arm at A'. The shoe lever disk and shoe lever are pivoted clockwise and the clutch is disengaged as outlined in Paragraph 5.b.(2)(c) above.

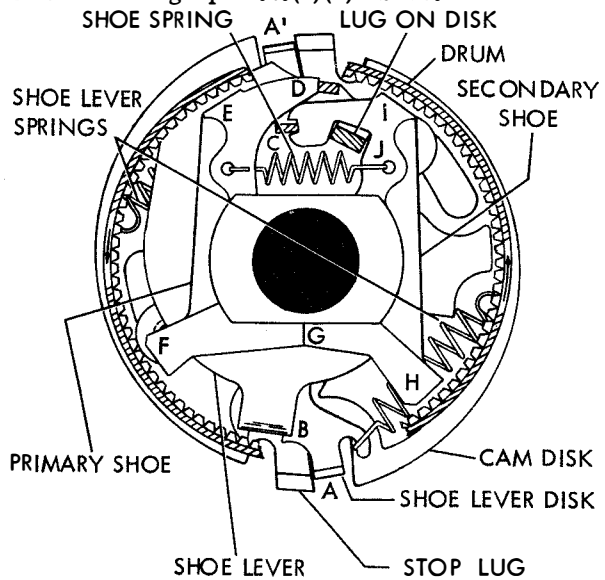

Figure 2-8. Two-Stop Clutch-Disengaged

5.b.(3) Selector Operation (Figures 2-3, 2-5 and 2-9).

5.b.(3)(a) The selector assembly consists primarily of two magnet coils (Figure 2-5), an armature and associated arms, bails, levers and latches (Figure 2-9). Five linkages, each of which consists of a selecting lever, a push lever and a punch slide latch, link the selector cam with the punch slides. Since the linkages are identical, only the No. 4 is shown in its entirety in Figure 2-9. As the selecting elements of the code combination are applied to the magnet, the cam actuates the selecting levers. When a spacing element is received, a marking lock lever is blocked by the end of the armature and a spacing lock lever swings to the right above the armature and locks it in the spacing position until the next signal transition occurs. Extensions on the marking lock lever prevent the selecting levers from following their cams. When a marking element is received, the spacing lock lever is blocked by the end of the armature and the marking lock lever swings to the right below the armature and locks it in the marking position until the

next signal transition occurs. During this marking condition, the selecting levers are not blocked by the marking lock lever extensions but are permitted to move against their respective cams. The selecting lever that is opposite the indent in its cam, while the armature maintains a marking condition, swings to the right, or selected, position, and the end of an associated push lever falls off a step on the selecting lever.

5.b.(3)(b) As the cam rotates, the selecting levers, together with any selected push levers, are moved to the left by the high part of their respective cams where they remain until the next code combination is received. The unselected push levers remain to the right. When the next code combination is received, a selector reset bail, lifted by its cam (Figure 2-9), strips the selected push levers from the selecting levers, and the push levers are returned to the right by their springs.

5.b.(3)(c) The selected push levers, in moving to the left, rotate associated punch slide

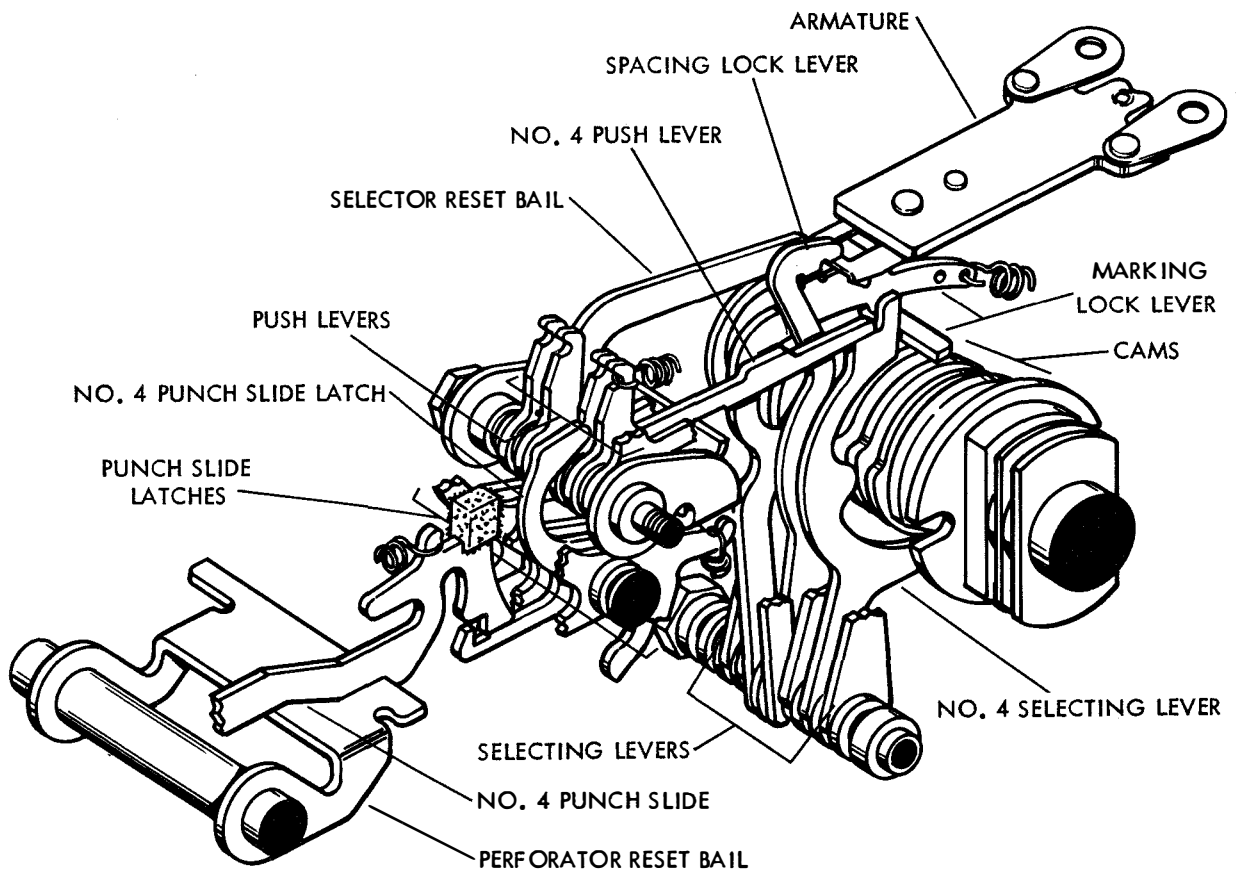

Figure 2-9. Selector

latches counterclockwise (Figure 2-9). Just before the fifth push lever is selected, the selecting cam through the function trip assembly causes the perforator reset bail to release the punch slides (paragraph 6.b.(1)). The unselected latches retain their associated slides to the right while the selected latches permit their slides to move to the left under spring tension. During the latter part of the function cycle, the reset bail returns the punch slides to their unselected position (see paragraph 7.b.(2)). The latches under spring tension return to their unselected position when the selected push levers are repositioned at the beginning of the next selecting cycle.

5.c. **TWO-SHAFT SELECTION** — When the control knob of the automatic send-receive keyboard is in the Keyboard (K) position (see Bulletin 249B), the selection of the two-shaft reperforator is essentially the same as that of the other units; i.e., the selecting mechanism receives the signaling code combinations, trips the function cam-clutch and controls perforating. When the control knob is turned from the K position to the Keyboard-Tape (K-T) or the Tape (T) position, a reset slide (Figure 2-4), actuated by the control cam, lifts the selector reset bail which strips the selected push levers and permits the selected punch slide latches to return to their unselected positions (see Figure 2-9). Since the selecting mechanism does not operate in the K-T and T positions, a means must be provided to keep the selector armature in its marking position, e.g., by energizing the selector magnet locally. When a key of the keyboard is manually depressed, it initiates a series of actions which culminate in selecting the proper combination of latches and tripping the function cam-clutch as described in Bulletin 249B.

5.d. **ORIENTATION** (Figure 2-5)

5.d.(1) For optimum performance, the selecting mechanism should be adjusted to sample the signaling code elements at the most favorable time. To make this adjustment, the operating margins are established through the range finder which provides a means of varying the time of sampling. The obtaining of this optimum setting is referred to as orientation.

5.d.(2) When the range finder knob (Figure 2-5) is pushed inward and rotated, its attached range finder gear moves the range finder sector (which supports the stop arm bail, stop arm and latch lever) either clockwise or counterclockwise about the selector cam-clutch. This changes the angular position at which the selector cam-clutch stops with respect to the marking and spacing lock levers. When an optimum setting is obtained, the range finder knob is released. Its inner teeth engage the teeth of the indexing lock

stud and hold the range finder mechanism in position. The setting may be read on the range scale opposite a fixed index mark.

6. **MOTION FOR PERFORATING AND FEEDING**

6.a. **GENERAL** — The main shaft's motion is conveyed to the perforating mechanism by the function mechanism which is comprised of a cam-clutch (Figure 2-3), a rocker bail (Figure 2-11) and a clutch trip assembly (Figure 2-10).

6.b. **FUNCTION CAM CLUTCH AND CLUTCH TRIP ASSEMBLY** (Figure 2-10)

6.b.(1) One- and Two-Cycle Units

6.b.(1)(a) The trip assembly is shown in its unoperated condition in Figure 2-10. A follower lever rides on a function trip cam which is part of the selecting cam-clutch. Near the end of the selecting cycle, as the main shaft rotates counterclockwise, the high part of the cam pivots the follower lever which through an attached adjusting arm rotates a main trip lever counterclockwise. A reset bail trip lever attached to the main trip lever lowers the perforator reset bail and releases the punch slides (paragraph 7.b.(1)); and an upper arm of the main trip lever moves out of the way of a clutch release which falls against a downstop and rotates a trip shaft counterclockwise. Immediately, the low part of the trip cam allows the follower lever to return to its unoperated position, and the upper arm of the main trip lever moves down against the release. When the trip shaft is rotated by the release, it moves an attached clutch trip lever out of engagement with the clutch shoe lever. The clutch engages and the cam-clutch begins its cycle. The internal operation of the clutch is the same as that of the selector clutch described in paragraph 5.b.(2) of this section.

6.b.(1)(b) About midway through the function cycle, an eccentric pin on the function cam lifts a reset arm which rotates the trip shaft clockwise. The release is moved up and allows the main trip lever to fall against the adjusting arm and raise the reset bail. The eccentric pin then moves out from under the reset arm and the release is permitted to return to its unoperated position against the main trip lever. When the cam-clutch assembly completes its cycle, the clutch shoe lever strikes the trip lever and the clutch is disengaged.

6.b.(2) Two-Shaft Unit — With the keyboard in the K condition, the function cam-clutch of the two-shaft reperforator is tripped in the same manner as the other units. However, in the K-T or T condition it is tripped by direct mechanical action from the keyboard as covered in Bulletin

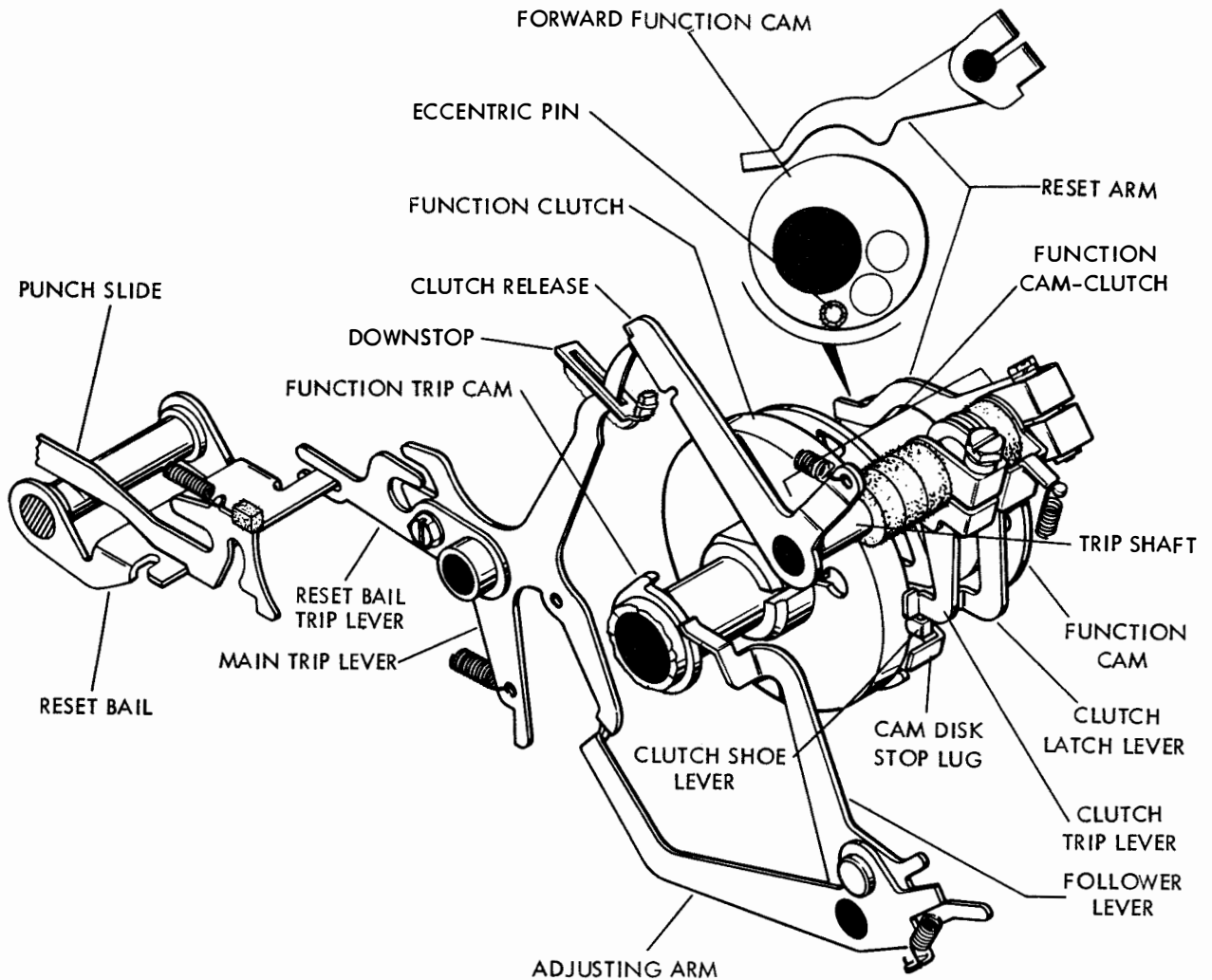

Figure 2-10. Function Cam-Clutch and Clutch Trip Assembly

249B. The function cam of the two-shaft unit has an additional camming surface on which rides a roller mounted on a keyboard follower arm (Figure 2-4). When the control knob is in the T position, this cam resets the keyboard.

6.c. **ROCKER BAIL** (Figure 2-11) — The function cam and the rocker bail translate the rotation of the shaft (or the function clutch drum in the case of the two-shaft unit) into simple harmonic motion which the bail transfers to the perforating mechanism (Figure 2-11). Each function cycle the function cams bear against rollers and cause the bail to rock to the left during the first part of the cycle and then back to its home position during the latter part of the cycle.

7. TAPE PERFORATING AND FEEDING (Figure 2-11)

7.a. **GENERAL** — The perforating mechanism rolls in feed holes, advances the tape and perforates combinations of chadless code holes corresponding to the code combinations received from the signal line. Intelligence is received from the selecting mechanism by the punch slides which select the proper punch pins in a punch block assembly (Figure 2-11). Motion from the rocker bail is distributed to the pins and the tape feeding parts by a main bail assembly, which includes a toggle bail, a toggle shaft, a slide post, toggle links, drag links and the punch slide reset bail.

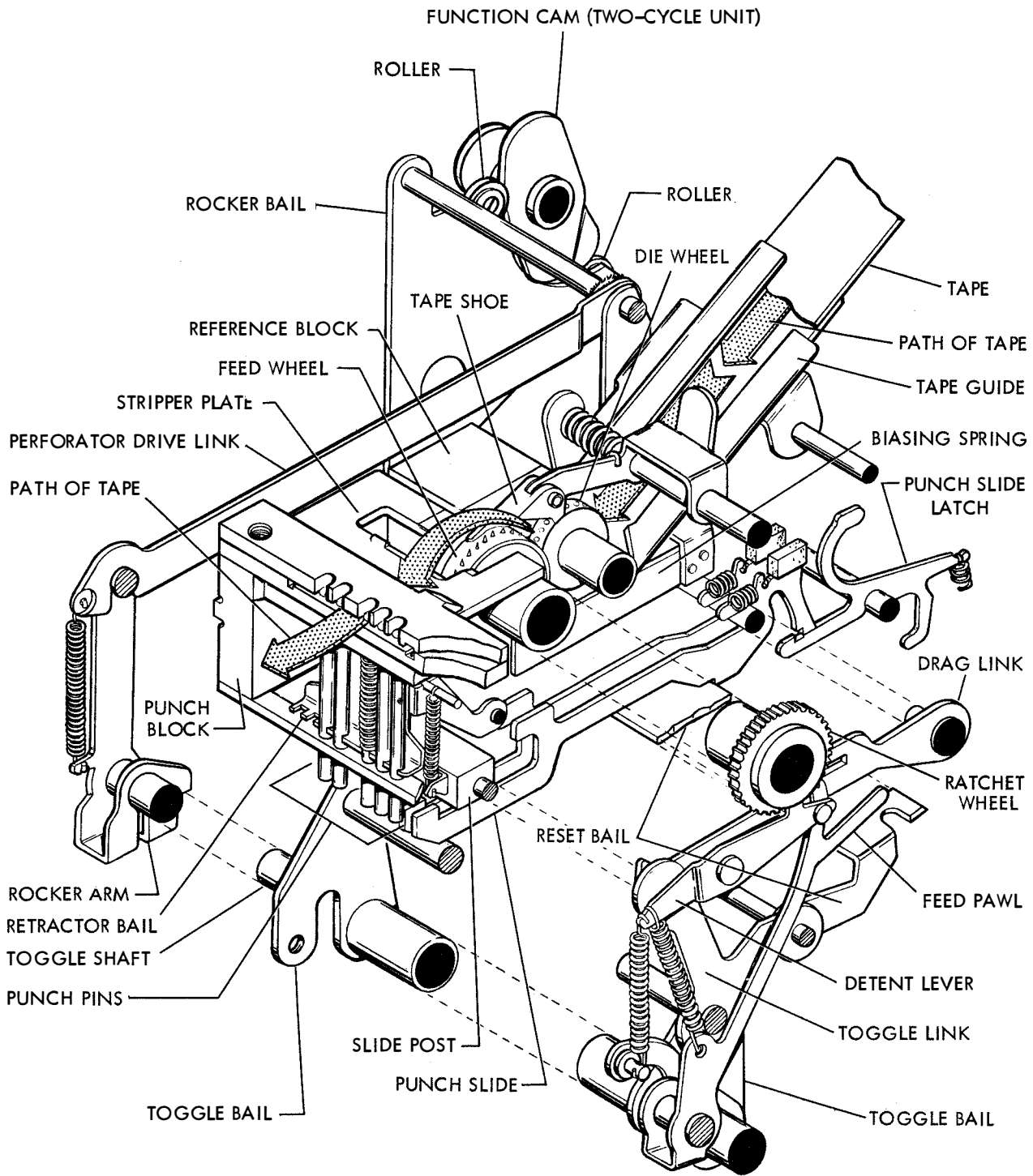

Figure 2-11. Perforating Mechanism

7.b. PERFORATING

7.b.(1) As described in paragraph 6.b.(1)(a), near the end of the selecting cycle the reset bail is lowered and releases the five punch slides (Figure 2-11). The selected slides move to the left and the unselected slides are retained to the right by their latches (paragraph 5.b.(3)(c)). In the selected position, a projection of each slide extends over the slide post. During the first part of the function cycle, the rocker bail moves to the left and, by means of a drive link and rocker arm, rotates the toggle shaft and bail counter-clockwise. Toggle links attached to the front and rear of the bail lift the slide post and move the reset bail to the left. The selected slides are carried upward by the post and force the associated punch pins through the tape. The slides pivot about the same point as drag links and thus become an integral part of the main bail assembly during the perforating stroke. A retractor bail, which engages notches in the punch pins, is pivoted clockwise as the pins move up through the tape. Approximately midway through the function cycle, the function clutch trip assembly lifts the reset bail as described in paragraph 6.b.(1)(b).

7.b.(2) During the last half of the cycle, the toggle bail is rotated clockwise and lowers the punch slides. The reset bail, moved to the right by the toggle links, drives the slides back to their unselected position where it holds them until the next operation. The retractor bail under spring pressure holds the punch pins down against the slides until the pins are retracted below the tape. The notches in the pins are long enough to allow the retractor bail to pivot its full amount without lifting the unselected pins against the tape, but are short enough to permit the bail to serve as a downstop for the pins and thus hold

them in the block. A compression spring is mounted on the No. 3 punch pin, and four tension springs are hooked to the slide post and the retractor bail. The main bail assembly, the retractor bail and the selected slides and pins move as a unit during the perforating stroke, and the retractor bail tension springs are not part of the load on the toggle bail shaft. The openings in the block above the tapethrough which the selected pins protrude are semicircular so that only the rear portion of the hole is severed.

7.c. FEEDING — Tape feeding is accomplished after perforation during the last half of each function cycle. The tape is threaded down through a tape guide and then up between a feed wheel and die wheel (Figure 2-11). A feed pawl, driven by the toggle bail, acts upon a ratchet and rotates the feed wheel which, by means of sharp pins and holes in the die wheel, rolls feed holes into the tape and advances it one character at a time. A detent with a roller that rides on the ratchet holds the feed wheel and tape in position during perforation. The detent and feed pawl springs are so positioned that the pressure of the detent on the ratchet is high during the first half of the cycle so as to hold the tape in position during perforation, but is low during idling and the last half of the cycle to facilitate tape threading and feeding. A tape shoe retains the tape on the feed wheel, and a biasing spring holds it back against a reference block so that the feed holes are punched a constant distance from the edge. The tape is stripped from the feed wheel by a stripper plate, passes into the punch block where it is perforated and finally emerges at the left. A biasing spring, which holds the tape back against a reference surface on the block, maintains a constant relationship between the code perforations and the edge of the tape.

