



BULLETIN 261B
STROBOSCOPIC TEST SET

LSS

TELETYPE[®]
CORPORATION
SUBSIDIARY OF *Western Electric Company* INC.
CHICAGO, ILLINOIS, U. S. A.

© 1959 and 1961 by Teletype Corporation
All rights reserved.



LIST OF EFFECTIVE PAGES

JULY, 1961
 (Supersedes March, 1959 Issue)

Page Number	Change in Effect
A to C	CHANGE 1
1-0	ORIGINAL
1-1	CHANGE 1
1-2	ORIGINAL
1-3 to 1-5	CHANGE 1
2-0	ORIGINAL
2-1	CHANGE 1
2-2	ORIGINAL
2-3 to 2-4	CHANGE 1
3-1	CHANGE 1
3-2	ORIGINAL
3-3	CHANGE 1
3-4	ORIGINAL
3-5 to 3-11	CHANGE 1
4-0 to 4-1	ORIGINAL
5-0 to 5-4	ORIGINAL
5-5	CHANGE 1
5-6	ORIGINAL
5-7 to 5-10	CHANGE 1
5-11 to 5-17	ORIGINAL
6-1 to 6-18	CHANGE 1

The above list indicates the effective pages as of the date of issue. Upon the receipt of change pages, insert them numerically and discard any superseded pages.

TABLE OF CONTENTS

Paragraph	Page	Paragraph	Page
SECTION 1 DESCRIPTION		USING TEST SET LSS200 OR LSS201	
1. SCOPE OF THE BULLETIN	1-1	a. Transmitter Distributor	3-1
2. PURPOSE AND BASIC PRINCIPLES	1-1	(1) Distributor Contacts	3-1
3. PHYSICAL LAYOUT	1-3	(2) Strobing Transmitter Sensing Contacts	3-3
4. ELECTRICAL CHARACTERISTICS	1-3	(3) Strobing Auxiliary Sensing Contacts for the Fixed Head Transmitter Distributor	3-3
a. Input	1-3	b. Reperforator	3-3
b. Rectifier Output	1-3	(1) Code Reading Contacts	3-3
c. Pulsing Signal	1-3	(2) Code Reading Contacts on the ASR Set	3-5
SECTION 2 PRINCIPLES OF OPERATION		c. Contacts Operating at 60, 75, 100, or 200 WPM	3-5
1. STROBOSCOPIC TEST SET	2-1	d. Strobing Signal Generator Contact of ASR Mounted Single Contact T-D	3-5
a. General	2-1	4. SWITCH SETTING FOR STROBING THE FOLLOWING UNITS USING THE STROBOSCOPIC TEST SET WHICH MOUNTS ON THE CONTROL BOX ASSEMBLY (LSS202)	3-5
b. Mounting Bracket	2-1	a. General	3-5
c. Motor Unit	2-1	b. Strobing Distributor Contacts	3-5
d. Gear Shift Assembly	2-1	c. Strobing the Transmitter Sensing Code and Auxiliary Contacts - Sequential Clutch Operation	3-7
e. Hub Assembly	2-1	d. Strobing Transmitter Sensing Auxiliary and Code Contacts - Simultaneous Clutch Operation	3-7
f. D. C. Power Supply	2-1	e. Strobing External Contacts Operating at 60, 75, 100 or 200 WPM	3-8
g. Control Switches and Cable Assembly	2-1	f. Strobing the LAK20 Keyboard Contacts	3-8
2. CIRCUIT ANALYSIS FOR LSS200 AND LSS201	2-1	g. Strobing Reperforator Code Reading Contacts	3-9
a. General	2-1	h. Strobing Reperforator Code Reading Contacts of the ASR Set	3-9
b. Power Input	2-3	i. Strobing Multi-Magnet Reperforator Auxiliary Contacts	3-10
c. Power On-Off Switch	2-3	j. Margin Check of the Multi- Magnet Reperforator Punch Selector Mechanism	3-10
d. Strobe-Orient Switch	2-3	k. Strobing Codomat Code Reading Contacts	3-10
e. Cl. Mag. Sens-Dist. Switch	2-3	l. Circuit Assurance Circuit Adjustment	3-11
f. Pulse On-Off Switch	2-3		
g. T-D Strobe Switch	2-3		
h. Selector Switch	2-3		
i. Perf. Strobe Switch	2-4		
j. Signal or Contact Input Jack	2-4		
3. SWITCH DESCRIPTION - LSS202	2-4		
a. Cl. Mag. Switch	2-4		
b. Contact Input Jack	2-4		
c. Unit Selector Switch	2-4		
d. Contact Selector Switch	2-4		
e. Kybd. Perf. and Reperf. Switch	2-4		
f. Codomat and Detector Switch	2-4		
g. Transmitter Switch	2-4		
h. Voltage Selector Switch	2-4		
SECTION 3 INSTALLATION AND OPERATION		SECTION 4 TROUBLE SHOOTING	
1. GENERAL	3-1		
2. TEST PROCEDURE	3-1		
3. CONTROL SWITCH SETTING FOR STROBING THE FOLLOWING UNITS			

Paragraph	Page	Paragraph	Page
1. GENERAL	4-1	3. TOOLS AND SPRING SCALES	5-1
a. Visual Inspection	4-1	4. ADJUSTMENTS	5-1
(1) Feeling	4-1	Motor Pinion	5-2
(2) Listening	4-1	Gear Shift Mechanism	5-3
(3) Inspecting	4-1	Slip Ring Assembly and Pulser	
		Contact	5-4
2. OVERALL TROUBLE SHOOTING	4-1	Base Plate Assembly	5-5
a. Preliminary Checks	4-1	Neon Lamp and Bracket Assembly	5-6
		Pulser Assembly	5-7
3. FUNCTIONAL SECTION - TROUBLE SHOOTING	4-1	Distributor Disc Assembly	5-8
a. Preliminary Check	4-1	Distributor Disc Assembly	5-9
b. Test Equipment	4-1	Adjustable Resistor	5-10
c. Testing	4-1	5. LUBRICATION	5-11
		SECTION 6 PARTS	
		1. GENERAL	6-1
1. GENERAL	5-1	2. EXPLODED VIEWS	6-2 to 6-15
2. ASSEMBLY AND DISASSEMBLY	5-1	3. NUMERICAL LIST OF PARTS	6-16 to 6-18

TELETYPE AND BELL SYSTEM CODE REFERENCE CHART		
STROBOSCOPIC TEST SET		
TELETYPE CODE (UNITS COVERED)	BELL SYSTEM CODE	WIRING DIAGRAMS
LSS200**	28A**	3537WD, Actual 3499WD, Schematic
LSS201**		3746WD, Actual 3747WD, Schematic
LSS202**	28B**	4210WD, Actual 4209WD, Schematic

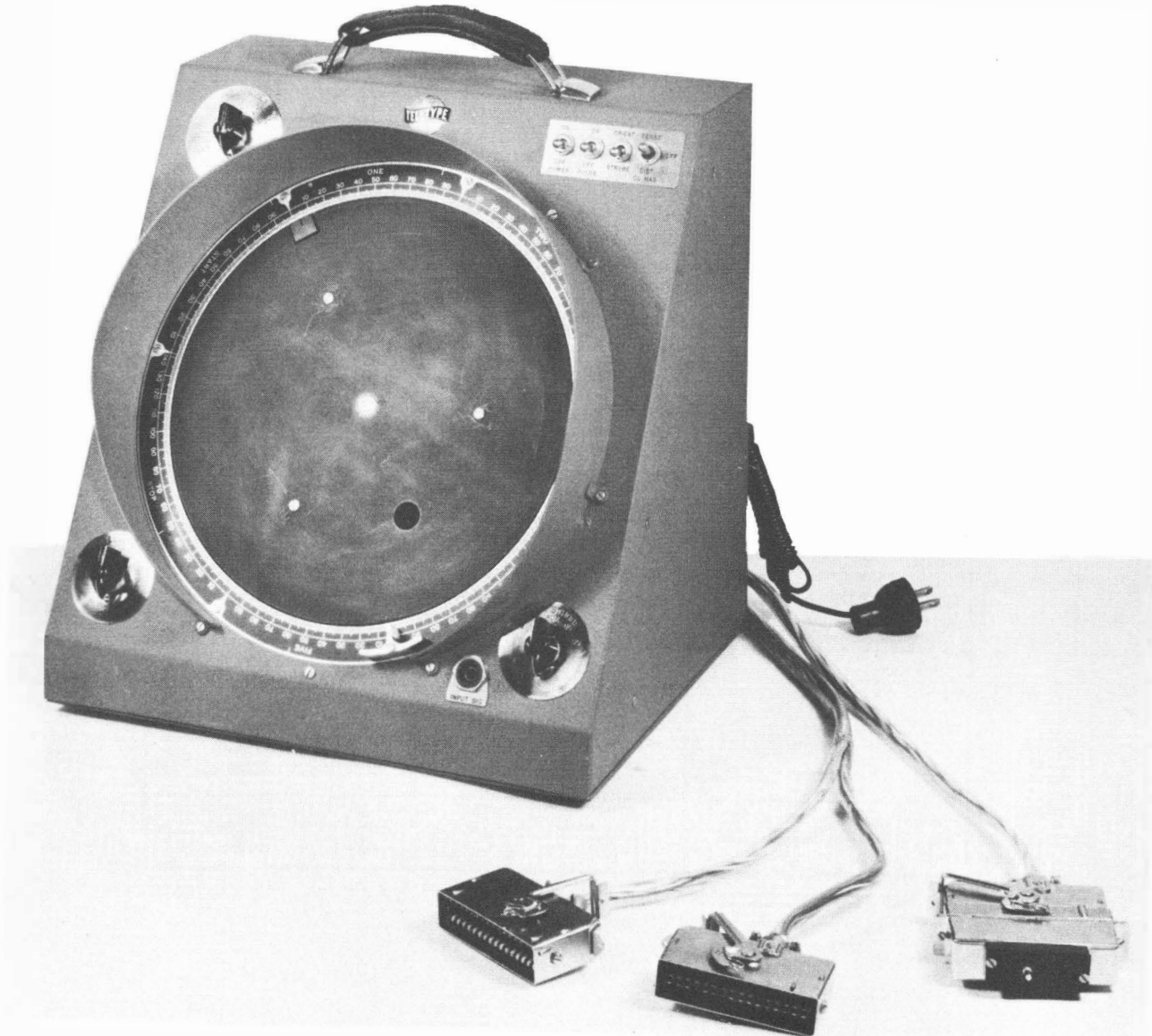

FIGURE 1-1 STROBOSCOPIC TEST SET
(Connecting Cables Removed From Storage Compartment)

SECTION 1

GENERAL DESCRIPTION

1. SCOPE OF THE BULLETIN

a. This bulletin contains instructions pertaining to the application, operation and maintenance of the Model 28 - Stroboscopic Test Set. The test set is a portable device for measuring the beginning, duration, and end of periodic current pulses initiated by the signaling contacts of teletypewriter units - particularly the Model 28 line of equipment.

b. Section 1 covers the general description, physical layout and electrical characteristics of the test set. Section 2 presents the principles of operation. Section 3 outlines the procedure for the operation of the test set. Sections 4 and 5 pertain to the care and maintenance of the unit. Section 6 provides an exploded view of each mechanism with part numbers and description.

c. Unless stated otherwise, reference to left or right, up or down, and front or rear apply to the unit as viewed from the operator's position.

2. PURPOSE AND BASIC PRINCIPLES

a. The Stroboscopic Test Set is arranged to display a trace of light around the inner diameter of a calibrated scale. A hub assembly which supports a neon lamp is arranged to revolve within the opening of the calibrated scale. The attached disk shields the lamp assembly with the exception of a narrow slot on the perimeter of the disk. As the disk is rotated at the exact speed of the unit to be "strobed", the current pulses initiated by the contacts to be checked will be displayed stroboscopically as a series of stationary bands of light.

b. The signal measuring scale is divided into five segments corresponding to the five unit code - plus the start and stop segments. Each segment is further divided into unit lengths to facilitate direct measurement of each pulse image. The scale may be moved clockwise or counterclockwise in order to align the start segment with the trace of the start pulse. A detenting feature prevents an accidental shift of the scale position. However, the scale may be rotated manually with little effort.

c. The pulse length and transition points (no current, and current to no current) may be readily determined relative to the mechanical operation of the equipment under test. The quality of the contact closure will be indicated by the presence or absence of discontinuities in the pulse pattern. By means of the control switches

on the front panel, it is possible to select individual pairs of contacts for strobing. The self-contained cables with their connectors provide rapid electrical connections to the units being tested. The set may be directly connected to the following units, through connectors:

(1) Model 28 Reperforator-Transmitter Set.

(2) Model 28 ASR Set.

(a) Pivoted and Fixed Head Multi-Contact Transmitter Distributor.

(b) Fixed Head Multi-Contact Transmitter Distributor.

(c) Pivoted Head Multi-Contact Transmitter Distributor.

(d) Perforators equipped with code reading contacts.

In addition, the Stroboscopic Test Sets LSS201 and LSS202 may be directly connected through connectors or adapters to the following units:

* (1) Self-Contained Model 28 Units

(a) Typing Reperforator with code reading contacts.

(b) Multi-Magnet Reperforator with verifying contacts.

(c) Fixed Head Multi-Contact Transmitter Distributor.

(d) Single Contact Transmitter Distributor.

** (2) Originating Station Set of Automatic Line Switching Systems.

(a) Model 28 Transmitter Distributor with pullback feature.

(b) Model 28 ASR Keyboard.

(c) Model 28 Multi-Magnet Reperforator.

(d) Model 28 Card Reader.

*LSS201

**LSS202

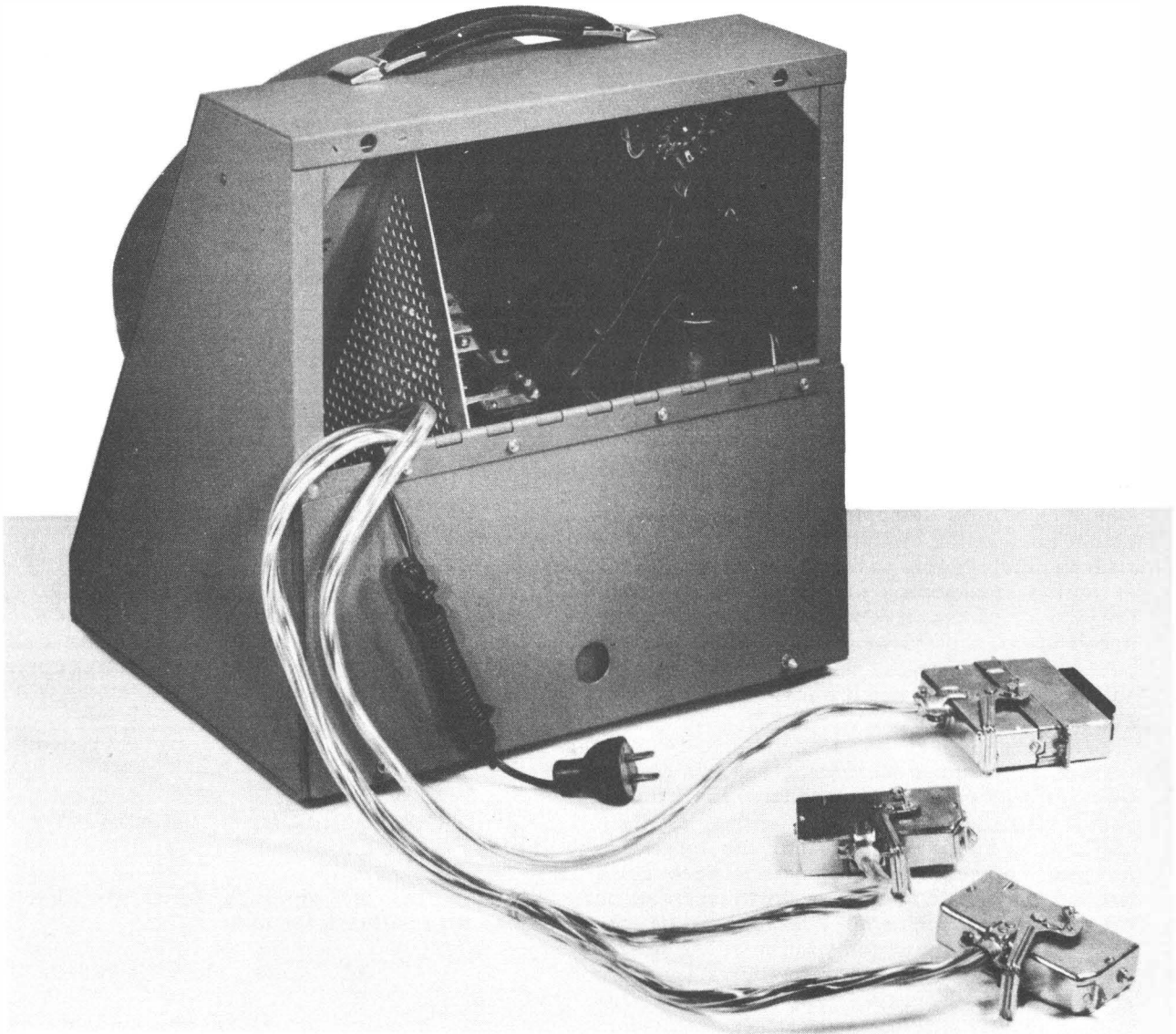

FIGURE 1-2 STROBOSCOPIC TEST SET
(Rear Door Open- Viewing Cable Compartment)

d. The test set is designed to "strobe" contacts operating at 60, 75, 100, and 200 WPM. The Test Set LSS201 comes equipped with a two lobed pulser contact cam and a two cycle signal measuring scale when units running at 200 WPM are to be strobed.

e. Provision is made on the LSS200 and LSS201 to connect the sensing contacts of either the fixed or pivoted head transmitter in series with the distributor contacts and viewed simultaneously. The Test Set LSS202 makes provision for comparing the sensing contacts of either the fixed or pivoted head transmitter to the distributor stop pulse.

f. The LSS202 Test Set is capable of generating a 35 ms. and 65 ms. spacing pulse which is used in the adjustment of the circuit assurance circuit. This selection of spacing pulses is made by means of control switches in the test set.

3. PHYSICAL LAYOUT

a. The test set is contained in a sheet aluminum cabinet with a sloping front. The approximate dimensions are as follows: 14 inches high, 14 inches wide and 11-1/2 inches deep. The sloping panel provides a good view of the image generated by the neon lamp when the test set is placed on a convenient table or bench. A hinged door at the rear of the cabinet provides access to the cable compartment and the gear

lever. The weight of the unit is 24 pounds.

b. The test set mounted on the control box (LSS202) is approximately 17 inches high, 14 inches wide and 11-1/2 inches deep. The control box contains the switches necessary for selecting the contact to be strobed and the cables necessary to connect the test set to the unit under investigation. The Switch Control Box is mechanically and electrically detachable from the Stroboscopic Lamp Cabinet.

c. Two major components - the hub assembly drive mechanism and the rectifier assembly - are located to the left of the cable compartment. A sloping mounting bracket supports the base plate containing the hub assembly with its drive mechanism and also positions the mechanism to align with the sloping panel. The rectifier assembly provides two D.C. outputs. One output energizes certain contacts to be strobed and the magnets; the higher potential output energizes the neon lamp.

4. ELECTRICAL CHARACTERISTICS

a. INPUT --- 115 volts, 60 cycles A.C., single phase; Watts -- 50.

b. RECTIFIER OUTPUT --- 120 volts D.C., 500 MA. and 240 volts D.C., 20 MA.

c. PULSING SIGNAL (to trigger selector magnet of reperforator, perforator and printer.)

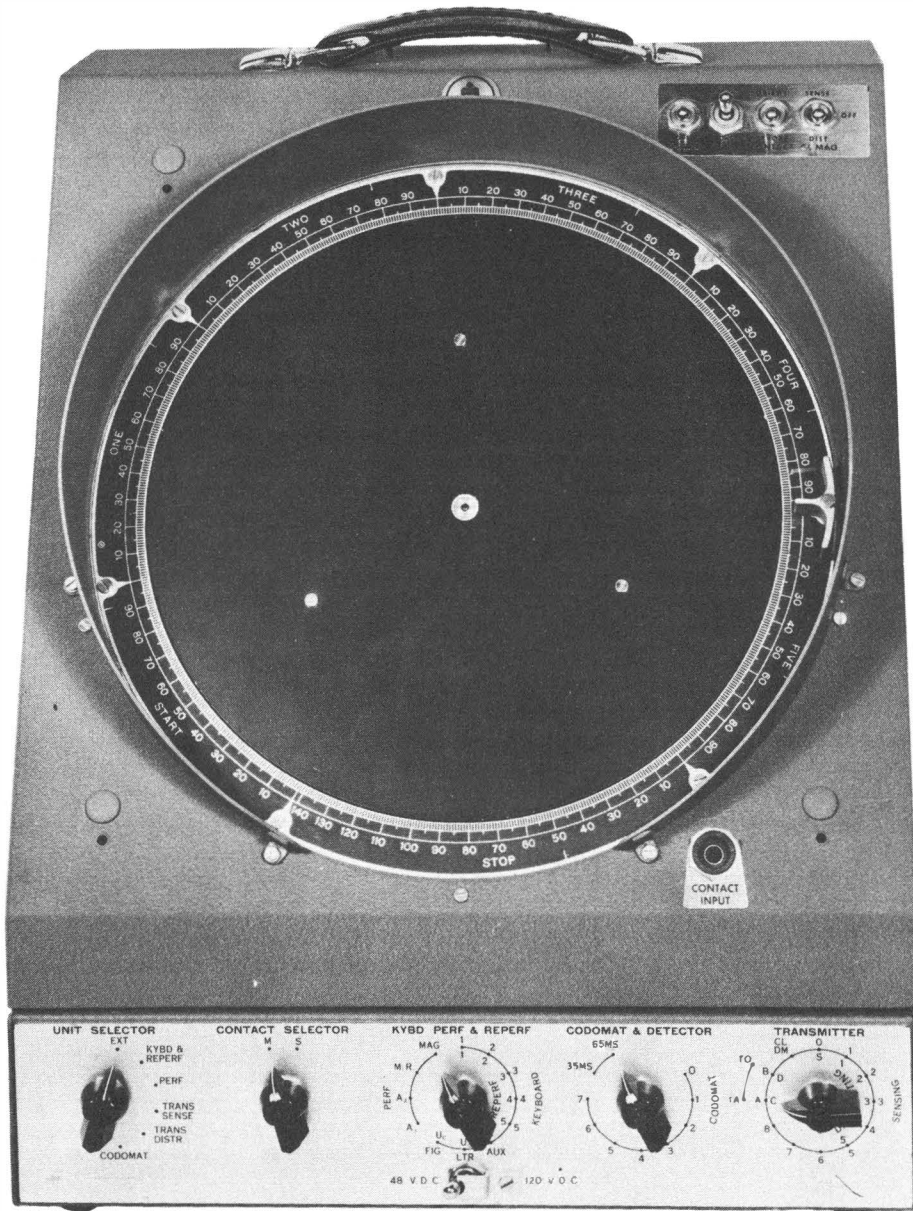

FIGURE 1-3. STROBOSCOPIC TEST SET (LSS202)

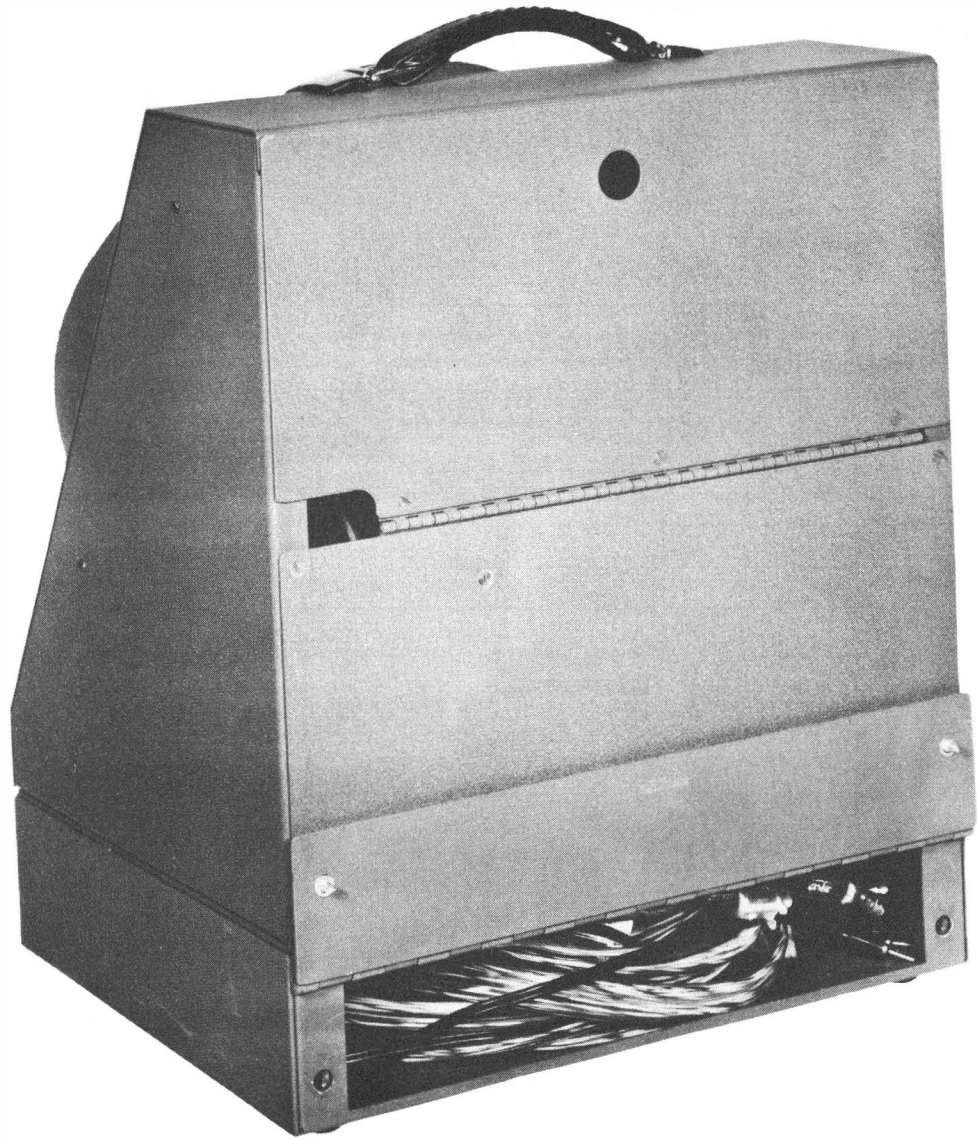

FIGURE 1-4. STROBOSCOPIC TEST SET (LSS202)
(REAR VIEW)

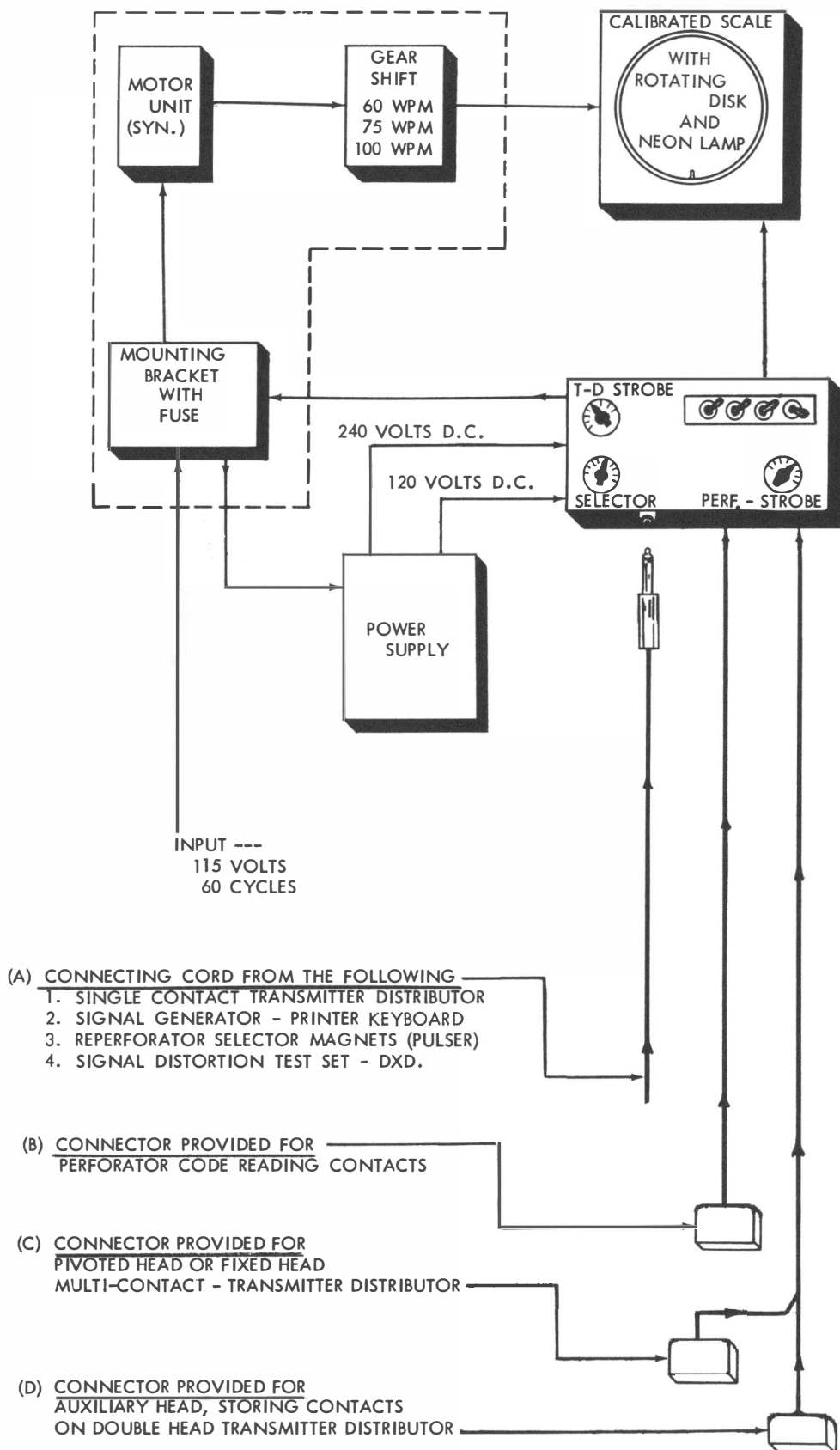

FIGURE 2-1 BLOCK DIAGRAM

SECTION 2

PRINCIPLES OF OPERATION

1. STROBOSCOPIC TEST SET

a. **GENERAL.** In the following section, which relates to the principles of operation, reference is made to the simplified block diagram in figure 2-1, the schematic circuit diagram figure 5-7 and the actual wiring diagram figure 5-8. The function of the individual circuits and mechanical linkage figure 2-1 is described in the sequence of operation.

b. **MOUNTING BRACKET.** Figure 6-4 --- This bracket is arranged to support the base plate containing the motor, gear shift assembly and hub assembly at an angle which will align with the sloping panel. The fuse receptacle is also attached to the mounting bracket and the area under the forward end of the bracket contains the resistor assembly.

c. **MOTOR UNIT.** Figure 6-7 --- This is a synchronous, 1800 RPM, capacitor start capacitor run, single phase motor. The rotor is equipped with a fan on each end. A shield in each end cap is formed so that the air is drawn in around the bearing housing, moved past the end of the stator winding and exhausted around the perimeter of the end shield. With this arrangement, the bearing lubricant is cooled prior to the stator winding. The capacitor is attached to the base plate and located to the right of the motor. The interconnecting cable is terminated at the terminal block on the left side of the cabinet.

d. **GEAR SHIFT ASSEMBLY.** Figures 6-4, 6-5 --- The lower shaft of the mechanism is coupled to the synchronous motor and the output shaft drives the hub assembly. A movable gear cluster, keyed to the output shaft, permits the selection of any one of three gear ratios (60, 75, and 100 WPM). The gear cluster is manually shifted toward the front or rear and locked into its new position by the shift arm assembly.

CAUTION

The gear cluster should not be moved while the motor is running.

The rear extension of the output shaft contains the cam which operates the pulser contact. The slip ring brushes are attached to the front of the gear mechanism to align with the slip rings on the hub assembly.

e. **HUB ASSEMBLY.** Figure 6-8 --- The hub assembly supports and moves the neon lamp in a circular path around the inner diameter of

the signal measuring scale. The disk covers the front opening and masks the extraneous light adjacent to the narrow slit on the lamp arm assembly. The rotating neon lamp is energized through the slip rings on the hub assembly - refer to figure 2-2.

f. **D. C. POWER SUPPLY.** Figure 6-9 --- The source of direct current to energize the neon lamp, the clutch magnet, the selector magnet and the contacts on the unit to be strobed is obtained from the self-contained rectifier. The rectifier is supported by a bracket attached to the left side of the cabinet. The input leads (115 Volts A. C.) and the output leads (120 Volts D. C. ; 240 Volts D. C.) terminate at the terminal block directly above. Note that the fuse on the input side is common to the motor unit. The fuse located on the rectifier mounting plate is connected with the 120 Volt D. C. output. Full wave rectification is used to obtain the 300 milliamperes, 120 Volt output. By connecting a 120 Volt, half-wave rectifier in series with the full-wave rectifier, a 240 Volt supply is obtained for the neon lamp circuit.

g. **CONTROL SWITCHES AND CABLE ASSEMBLY.** Figures 6-3, 6-11 --- The various control switches are located near each corner of the front panel (Figure 3-1). This control circuitry permits the operator to select the desired contacts of the unit to be "strobed". The main cable links the control switches with the unit to be tested by means of the 32 pin connectors. Note that the branch with the two connectors (male and female) will connect combined units using the pivoted head and fixed head. The branch with the single connector is arranged for connection to the code reading contacts and is equipped with an adapter to accommodate the 20 pin connector used on certain perforators. The input signal jack located on the front panel provides for the strobing of individual contacts such as the keyboard signal generator.

2. CIRCUIT ANALYSIS FOR LSS200 AND LSS201

a. **GENERAL.** The circuit described in the following text is shown in the overall schematic diagram (Figure 5-11) and the actual wiring diagram (Figure 5-12). Refer to Figure 3-1 for the location and nomenclature of each switch.

NOTE

Except for the Perforator Strobe Switch, the Control Switches for the Stroboscopic Test Sets LSS200 and LSS201 are identical.

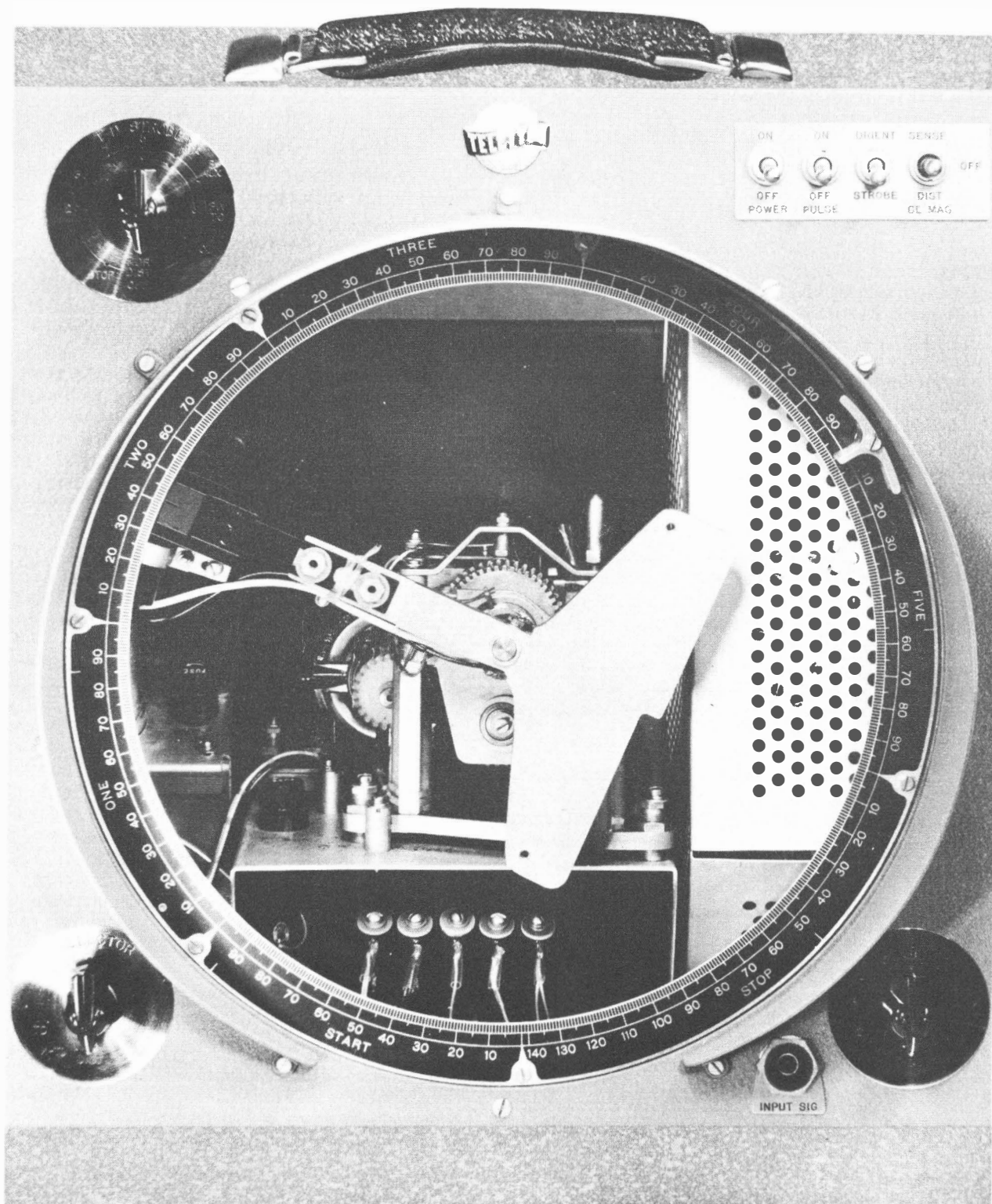

FIGURE 2-2. STROBOSCOPIC TEST SET
(WITH DISK REMOVED TO VIEW LAMP ARM AND MECHANICAL DRIVE)

b. **POWER INPUT** --- The 115 Volt, 60 cycle, power cord is attached to the terminal block and from this termination one lead branches to connect with the motor and the rectifier input. The other lead completes the circuit through the motor fuse and the power switch.

c. **"POWER ON-OFF" SWITCH** --- The S.P.S.T. switch is arranged to energize the motor and rectifier simultaneously.

d. **"STROBE-ORIENT" SWITCH** --- This is a D.P.D.T. switch which conditions the neon lamp circuit. In the STROBE position, the neon lamp is conditioned to produce the trace of the individual contacts selected. In the ORIENT position the neon lamp is conditioned to produce a trace of all distributor contacts in series with their respective sensing contacts.

e. **"CL MAG SENSE-DIST" SWITCH** --- This is a S.P.D.T. switch with its OFF position at the center. The purpose of the switch is to energize either the distributor clutch magnet or the sensing clutch magnet on the transmitter distributor to be strobed. In its DIST position, the switch completes the return circuit (ground) to the distributor clutch magnet. In its SENSE position, the switch completes the return circuit (ground) to the sensing clutch magnet. When the sensing clutch is tripped and the shaft starts its rotation, the distributor clutch contacts function to energize the distributor clutch magnet. The distributor clutch magnet may be energized directly when strobing the transmitter auxiliary contacts.

f. **"PULSE ON-OFF" SWITCH** --- If a reperforator is connected to the test set, some means of operating the selector magnet is needed in order to strobe the code reading contacts. A pulse generated by the test set to simulate the normal start pulse is produced by the cam and pulser contacts attached at the rear of the gear shift mechanism. The PULSE switch shunts the pulser contacts when units other than the reperforator are strobed.

g. **"T-DSTROBE" SWITCH** --- The transmitter distributor strobe switch (Figures 3-2 and 6-2) is a four section, ten (active) position switch that is arranged to select the individual contacts on the transmitter distributor to be strobed.

NOTE 1

The dots on the outer circle of the switch plate refer to the electrical contacts associated with the distributor shaft.

NOTE 2

The dots on the inner circle of the switch plate

refer to the electrical contacts associated with the sensing shaft.

(1) The section of the switch marked DIST in the schematic wiring diagram of Figure 5-7 provides for the selection and interconnection of the individual contacts on the distributor shaft to the neon lamp circuit.

NOTE 3

Position PIV of Figure 3-1 is not a part of T-D STROBE switch, however RDR is. Therefore, place SELECTOR switch in its TD position and the T-D STROBE switch on RDR.

(2) In the same manner, the section of the switch marked FIXED HEAD in the schematic wiring diagram of Figure 5-11 provides for the connection of the test set to the contacts associated with the fixed head sensing mechanism. With respect to the switch plate markings of Figure 3-1, place SELECTOR switch in X-TD position, T-D STROBE in RDR position, and CL MAG in DIST position.

(3) The section of the switch marked DIST CLUTCH (Figure 3-1) conditions the distributor clutch circuit so that the clutch is pulsed by the distributor clutch contacts when the #1 through #5 contacts are strobed. When the auxiliary contacts, clutch contacts, and tape out contacts are to be strobed, the switch conditions the distributor clutch circuit so that power is applied continuously to the distributor clutch magnet.

h. **"SELECTOR" SWITCH** --- This is a four section, three position switch located on the lower left corner of the front panel. The purpose of the switch is to select the output leads in the main cable that are associated with either of the following set of contacts on the respective unit to be strobed.

(1) Distributor - multi-contacts (DIST)

(2) Storing Switch - multi-contacts, associated with the pivoted head sensing mechanism (TD)

(3) Storing Switch - multi-contacts, associated with the fixed head sensing mechanism (auxiliary transmitter) (X-TD)

The fourth section of the switch, in conjunction with the clutch magnet switch, is arranged to complete the trip magnet circuit and to energize the contacts of the particular unit to be strobed. The first two sections are arranged to connect the multi-contacts of either transmitter in series with the respective contacts of the distributor. The third section is arranged to provide the

return circuit (ground) to the distributor multi-contacts and to connect the neon lamp in the circuit to be strobed.

i. "PERF STROBE" SWITCH --- This is a single section, eight (active) position switch arranged to insert the respective code reading contacts in series with the neon lamp circuit. Note the switch is retained in its T-D position except when strobing the code reading contacts. In addition the PERF STROBE switch on the LSS201 enables the signal generator of the single contact TD to be viewed in the number one contact position of the switch.

j. SIGNAL OR CONTACT INPUT JACK --- This jack is connected in series with the leads of the reperforator magnet and with the neon lamp circuit, to facilitate the checking of certain units. The following applications are listed for use with Model 28 Equipment.

(1) External contacts such as the signal generator used on the single contact transmitter distributor and the Model 28 keyboard may be plugged into the jack.

CAUTION

The contacts must have no electrical potential and must operate at the same speed as the test set.

(2) An external pulser contact may be connected to the jack to operate the reperforator for checking selector operation.

3. SWITCH DESCRIPTION - LSS202

NOTE

The description of the POWER Switch, PULSE Switch, and STROBE-ORIENT Switch as given in Paragraph 2 are common to the Stroboscopic Test Sets LSS200, LSS201, and LSS202. The following switch descriptions apply only to the Stroboscopic Test Set LSS202.

a. "CL MAG" SWITCH --- This is a S. P. D. T. switch which controls the transmitter distributor clutch trip magnets of the units being tested. In the DISTRIBUTOR position, this switch supplies ground to the distributor clutch circuit. In the SENSE position ground is supplied through the distributor clutch contact to the sensing clutch magnet and the distributor clutch magnet.

b. "CONTACT INPUT" JACK --- This jack provides a means of strobing external contacts, which have no electrical potential of their own, providing the contacts are operating at 60, 75, 100, or 200 WPM.

c. "UNIT SELECTOR" SWITCH --- This

is a six section, six pole, six position rotary switch. This switch provides selection of the unit whose contacts are to be strobed.

d. "CONTACT SELECTOR" SWITCH --- This is a five section, thirty pole, two position rotary switch. This switch provides the selection of the marking or spacing side of transfer contact pileups on those units that employ transfer contacts.

e. "KYBD, PERF AND REPERF" SWITCH --- This is a five section, five pole, twelve position rotary switch which provides the following:

(1) Strobing of the five code reading contacts, auxiliary, letters, and figures contacts of the keyboard so equipped.

(2) Strobing of the five code contacts, auxiliary and universal contacts of the reperforator.

(3) Strobing of the auxiliary I and auxiliary II and magnet release contacts of the multi-magnet reperforator.

(4) Means for energizing, with a minimum current pulse, the punch selector magnets of the multi-magnet reperforator, in order to check the operating margin of its punch selector mechanism.

f. "CODOMAT AND DETECTOR" SWITCH --- This is a three section, three pole, eleven position switch which provides for the following:

(1) Strobing of the codomat code reading contacts.

(2) Means for selecting a 35 ms. or 65 ms. spacing pulse for adjusting the circuit assurance circuit.

g. "TRANSMITTER" SWITCH --- This is a three section, three pole, twelve position rotary switch. It provides for the strobing of the code reading and auxiliary contacts on the sensing shaft of the fixed head, multi-contact transmitter distributor. It also strobes contacts operated by the sensing shafts of the pivoted and fixed head, multi-contact transmitter. This switch provides for strobing the distributor code and auxiliary contacts on the distributor shafts.

h. "VOLTAGE SELECTOR" SWITCH --- This is a S. P. D. T. switch, which depending upon the operating voltage, will provide 48 Volts D. C. or 120 Volts D. C. to the clutch magnets of the apparatus under test. The switch is normally locked in the 48 Volt D. C. position and must be deliberately unlocked with a screwdriver if the 120 Volt D. C. is required. Cables and connectors are supplied with the LSS202 for connecting a 48 Volt D. C. power supply to the test set.

*MUST REMOVE CAP ACROSS CONTACTS
WHEN STROBING TO GET TRUE READING*
261B

SECTION 3

INSTALLATION AND OPERATION

1. GENERAL

a. Since the test set is a portable device, there is no installation required other than plugging the unit into a convenient 115 Volt 60 cycle outlet. The self-contained cables with connectors facilitate rapid connection to the Model 28 line of equipment. An ample length of cable is furnished in order that the test set may be placed at a convenient eye level.

b. The self-contained rectifier supplies the D. C. potential (240 Volts) for the neon lamp and the D. C. potential (120 Volts) to energize the contacts to be strobed. An external source of potential is not compatible except when strobing the Line Switching System equipment, 48 Volts D. C. is obtained from the ASR under test.

CAUTION

Care should be exercised not to include the line battery in the circuit of the unit to be strobed.

c. In the event that an electrical noise suppressor is used across the signal contacts such as the keyboard signal generator, the trailing edge of each trace on the test set will be distorted. The image will carry over into the adjacent section of the calibrated scale. This condition is overcome by disconnecting a lead of the noise suppressor from its terminal.

2. TEST PROCEDURE

a. Open the rear door of the Test Set (LSS200 and LSS201) and remove the cables from the compartment. Connect the proper cable adapter to the unit being tested. The various cables are marked for quick identification. Connect one end of the appropriate cable to the unit under test. Connect the other end of the cable to the corresponding plug on the test set. (When the perforator in the Automatic Send-Receive Set is to be strobed, it is necessary to use the adapter that is furnished to convert the 32 point connector to a 20 point connector.)

b. The Signal or Contact Input Jack, whichever is applicable, is located on the front panel and is arranged to open the lamp circuit. This is to facilitate the connection of contacts not readily attached to a connector or to provide for the pulsing of a reperforator from an external source. The jack is also used to attach the signal cord from a DXD for calibration checks of the test set.

WARNING

Since the 240 V potential required for the neon

lamp is present at the jack, do not attempt to feed any external current source into the jack.

c. With the rear door opened and the power switch in its off position, move the gear shift lever to coincide with the speed of the unit to be strobed. The handle should be depressed to disengage the detent and then moved toward the front or rear to obtain the 60, 75, or 100 WPM speed requirement. It is necessary to use the alternate signal measuring scale (#139274) with the gear shift in the 100 WPM position for strobing contacts operating at 200 WPM.

3. CONTROL SWITCH SETTING FOR STROBING THE FOLLOWING UNITS USING TEST SET LSS200 OR LSS201

NOTE

Disconnect all connectors attached to the unit being strobed; however the motor should be operable. Connect the appropriate cable from the test set to the unit and make use of the adapter to reach the code reading contacts on the ASR installation.

a. TRANSMITTER DISTRIBUTOR

(1) Distributor Contacts

(a) With test set controls (see fig. 3-1) positioned as indicated below, the stroboscope should display a continuous trace.

<u>SWITCH</u>	<u>POSITION</u>
POWER	ON
PULSE	OFF
ORIENT-STROBE	STROBE
CL MAG	DIST
T-D STROBE	OFF
SELECTOR	DIST
PERF-STROBE	T-D

(b) With the exception of the T-D STROBE switch which is moved to its stop position all other switches retain the same position as above. Position the signal measuring scale to align the beginning of the start segment with the start pulse trace. Move T-D STROBE switch to position #1 to observe trace of contact. Advance switch one step at a time to observe each

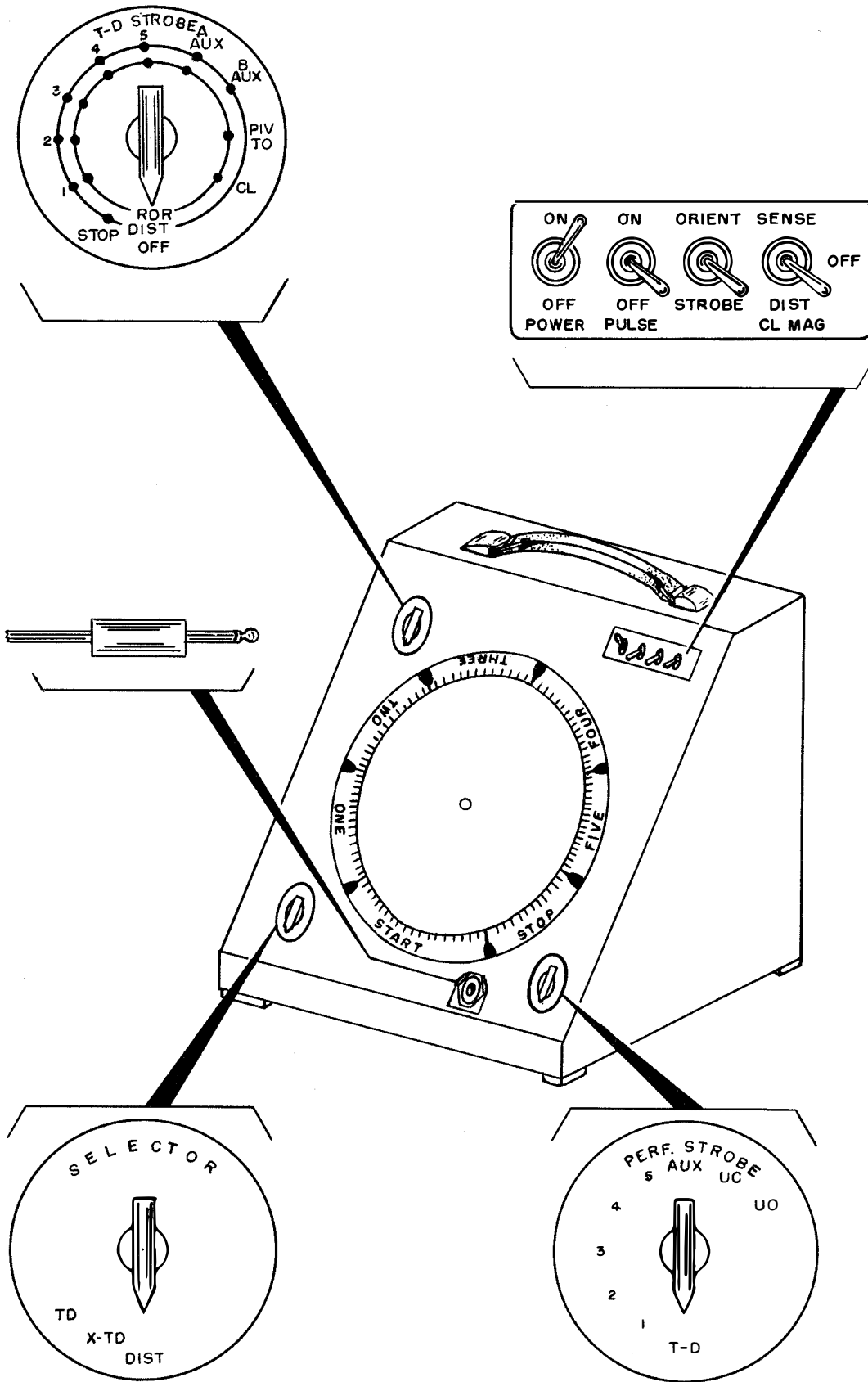

FIGURE 3-1 CONTROL SWITCHES

successive trace. Check contacts "A" and "B".

NOTE

The dots on outer circle of the switch plate refer to contacts associated with the distributor shaft. See figure 3-1.

(2) Strobing Transmitter Sensing Contacts

(a) Position Test Set controls as follows:

<u>SWITCH</u>	<u>POSITION</u>
POWER	ON
PULSE	OFF
ORIENT-STROBE	ORIENT
CL MAG	SENSE
T-D STROBE	STOP
SELECTOR	T-D
PERF-STROBE	T-D

(b) With switches positioned as indicated above, the test set will display the complete character that is being sensed on the unit under test. Position the signal measuring scale to align the beginning of the start segment with the beginning of the start pulse trace.

(c) Reposition the STROBE-ORIENT switch to STROBE. The test set will now display sensing contacts No. 1 through No. 5, when the T-D STROBE switch is turned to the desired position.

(d) To strobe the auxiliary, tape out, or distributor clutch trip contacts:

1. Turn T-D STROBE switch to its AUX A position.

2. Turn the CL MAG switch to OFF position.

3. Turn off the motor in the unit under test.

4. Turn the CL MAG switch to the SENSE position.

5. Turn on the motor in the unit under test.

6. Turn the STROBE-ORIENT switch to the ORIENT position.

7. Orient the scale so that the beginning of the start pulse displayed coincides with the beginning of the start pulse on the scale.

8. Reposition the STROBE-ORIENT switch to STROBE.

The test set will now display the auxiliary A contact in the correct time relationship with the distributed signal. To strobe the tape out contacts rotate the T-D STROBE switch to its PIV/TO position and view the trace. By moving the T-D STROBE switch to the CL position, a trace of the distributor clutch contacts can be viewed.

CAUTION

The T-D STROBE switch must not be rotated to any one of the sensing contact positions prior to this check. Should an overtravel occur in the rotation of the switch, it will be necessary to re-synchronize the contacts.

(3) Strobing Auxiliary Sensing Contacts for the Fixed Head Transmitter Distributor -- With selector switch in its X-TD position repeat operations outlined in the preceding paragraph.

b. REPERFORATOR

(1) Code Reading Contacts

(a) Position the control switches as follows:

<u>SWITCH</u>	<u>POSITION</u>
POWER	ON
PULSE	ON
ORIENT-STROBE	STROBE
CL MAG	OFF
T-D STROBE	OFF
SELECTOR	DIST
PERF-STROBE	NO. 1

(b) With the control switches positioned as above, the test set will display the No. 1 contact trace. Rotate the PERF-STROBE switch one step at a time to view each trace of the remaining contacts.

(c) The selector of the reperforator under test will be pulsed at the correct speed by the internal pulser within the test set. If external pulsing of the selector is desired, the pulse switch should be set in the OFF position.

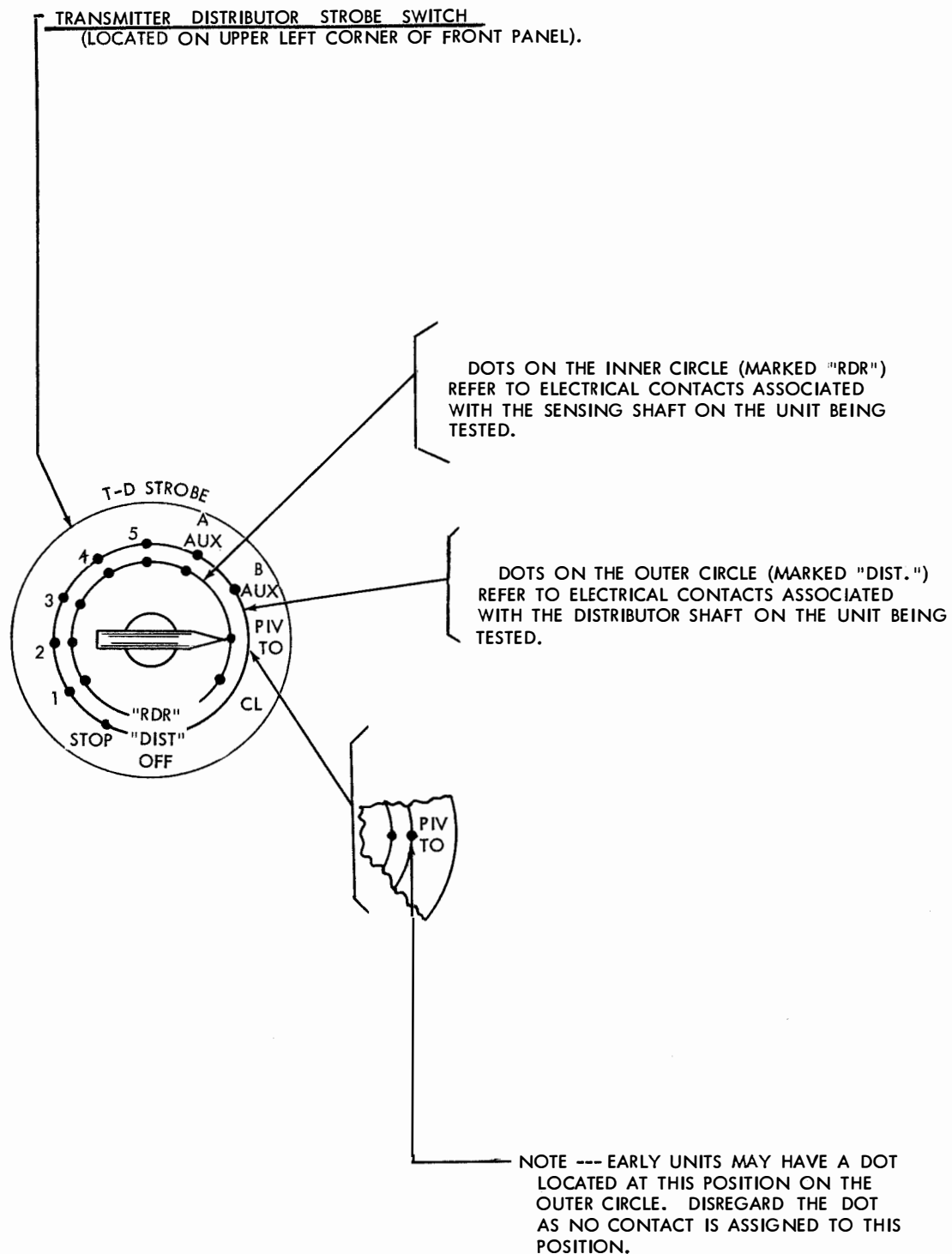

FIGURE 3-2 T-D STROBE SWITCH

The external pulser can then be plugged into the signal or contact input jack. The external pulser must not have any electrical potential.

(2) Code Reading Contacts on the ASR Set

(a) Repeat the procedure outlined in paragraph 3.b. above, except pulse the perforator either mechanically or electrically from the keyboard. The pulse may be initiated by holding the LTRS and REPT keylevers down.

(b) To accurately measure the closure of ASR code reading contacts, the ASR must be geared for 100 WPM. However, the 60 and 75 WPM speeds may be used to determine the general quality of the contact closure.

c. CONTACTS OPERATING AT 60, 75, 100, OR 200 WPM

(1) Signal Generator or Similar Contacts

(a) Position the control switches as follows:

<u>SWITCH</u>	<u>POSITION</u>
POWER	ON
PULSE	OFF
ORIENT-STROBE	STROBE
CL MAG	OFF
T-D STROBE	OFF
SELECTOR	DIST
PERF-STROBE	T-D

(b) With the control switches positioned as indicated above and the contact to be "strobed" plugged into the SIGNAL OR CONTACT INPUT jack, the test set will display the trace of the contact in operation.

(c) With the control switches positioned as above and no signal input, a circular trace will be displayed on the test set. This arrangement may be used to check the neon lamp.

(d) Pulser Contact -- With the exception of the PULSE "ON-OFF" switch which is moved to its ON position, all control switches retain the same position as listed above. The test set will display the trace initiated by the perforator pulsing contacts.

*d. STROBING SIGNAL GENERATOR CON-

TACT OF ASR MOUNTED SINGLE CONTACT T-D

(1) Position the control switches as follows:

<u>SWITCH</u>	<u>POSITION</u>
POWER	ON
PULSE	ON
STROBE-ORIENT	STROBE
CL MAG	OFF
T-D STROBE	OFF
SELECTOR	DIST
LARP, LXD & PERF-STROBE NO. 1	

(a) The signal trace will appear only in the No. 1 contact position of the LARP, LXD and PERF-STROBE.

4. SWITCH SETTING FOR STROBING THE FOLLOWING UNITS USING THE STROBOSCOPIC TEST SET WHICH MOUNTS ON THE CONTROL BOX ASSEMBLY (LSS202)

a. To remove the cables turn the two fasteners at the rear of the control box assembly a quarter turn to open the compartment door. The various cables are marked for quick identification. Remove all connectors from the unit under test before connecting the test set. Connect the appropriate cable from the test set to the unit under test. Set the Voltage Selector switch in the 48 V D.C. or 120 V D.C. position, depending upon the voltage requirement of the clutch trip magnets of the units under test. When using the 48 V D.C. power supply located under the ASR Cabinet of the Send Station in the Automatic Line Switching System, disconnect the A. C. input and D. C. output cords of this power supply from the cabinet. Connect the A. C. input cord of the 48 V D.C. rectifier to the A. C. power cord from the test set. Connect the black and red probes from the test set into their corresponding test jacks on the rectifier. If contacts with no electrical potential (not reached by connectors) are to be tested, use the Signal Input jack. Set the gear shift for the speed of the unit to be strobed. Position the control switches as outlined in the following paragraphs.

b. STROBING DISTRIBUTOR CONTACTS

(1) Position the control switches as follows:

*LSS201

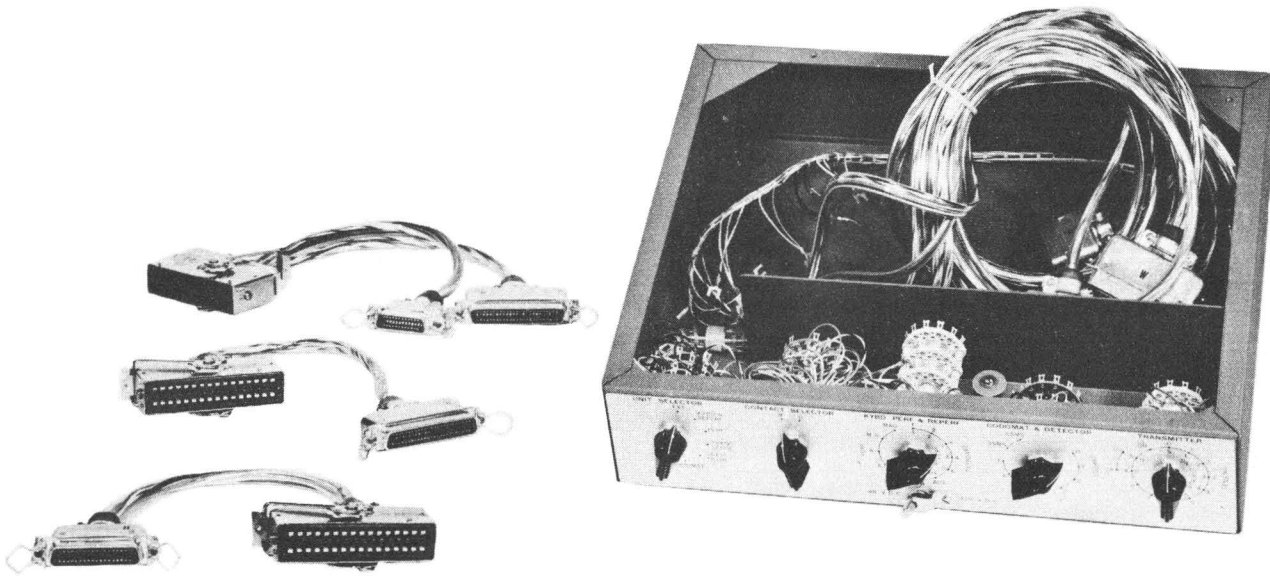

FIGURE 3-3. CONTROL BOX ASSEMBLY

<u>SWITCH</u>	<u>POSITION</u>
POWER	ON
PULSE	OFF
STROBE-ORIENT	STROBE
CL MAG	SENSE
UNIT SELECTOR	TRANS. DIST.
CONTACT SELECTOR	M
TRANSMITTER	S
VOLTAGE SELECTOR	48 V D. C. or 120 V D. C. (as unit to be tested is wired)

Remaining switch positions are immaterial.

(2) The stop-run switch of the pull back transmitter or the tight-tape switch of the auxiliary fixed head multi-contact transmitter, or the last character switch of the pivoted head transmitter, whichever is applicable, should be momentarily operated to stop the rotation of the transmitter shaft. This is done to establish synchronization between the sensing and distributor shafts of the transmitter under test. This does not apply to all fixed head transmitters.

(3) With the switches arranged as indicated above, the test set will display a trace of the stop pulse. Orient the scale so that the stop pulse on the scale coincides with the stop pulse trace. The remaining code contacts may be strobed and read out directly from the scale by rotating the transmitter switch to the appropriate position. Strobing of the distributor auxiliary contacts is accomplished by rotating the transmitter switch to the appropriate position.

c. STROBING THE TRANSMITTER SENSING CODE AND AUXILIARY CONTACTS - SEQUENTIAL CLUTCH OPERATION

(1) Position the control switches as follows:

<u>SWITCH</u>	<u>POSITION</u>
POWER	ON
PULSE	OFF
STROBE-ORIENT	STROBE
CL MAG	SENSE
UNIT SELECTOR	TRANS. SENSE

<u>SWITCH</u>	<u>POSITION</u>
TRANSMITTER	0
CONTACT SELECTOR	M
VOLTAGE SELECTOR	48 V D. C. or 120 V D. C. (as unit to be tested is wired)

Remaining switch positions are immaterial.

(2) Orient the scale so that the stop pulse on the scale coincides with the stop pulse trace, as covered in paragraph 4. b. (1) thru (3).

(3) With the switches arranged as indicated above, the test set will display a trace of the zero code level of the pull back transmitter if this unit is under test, and will display no trace if the fixed or pivoted head transmitter is under test. The remaining 1 thru 7 code levels and sensing auxiliary contacts of the pull back transmitter and the five code levels of the fixed and pivoted head transmitter may be strobed by rotating the transmitter switch to the appropriate position. When strobing the code reading contacts of the pull back transmitter, it is necessary to feed a continuous loop of "Blank" and "Rub-out" tape thru the transmitter in order to obtain a measurement of contact closure. The eighth code level of the pull back transmitter will not display a trace when the test loop is used, but will display a trace when the test loop is removed.

NOTE

During the above test procedure the UNIT SELECTOR switch must not be turned after being set to TRANS SENSE position. If it is the stop pulse reference may be lost and it will become necessary to reorient the scale as covered in paragraph c. (2).

d. STROBING TRANSMITTER SENSING AUXILIARY AND CODE CONTACTS - SIMULTANEOUS CLUTCH OPERATION

(1) Position the control switches as follows:

<u>SWITCH</u>	<u>POSITION</u>
POWER	ON
PULSE	OFF
STROBE-ORIENT	ORIENT
CL MAG	OFF

<u>SWITCH</u>	<u>POSITION</u>	<u>NOTE</u>
UNIT SELECTOR	TRANS. SENSE	During the above test procedure the unit selector switch must not be turned. If it is, the contacts must be re-synchronized using the above procedure - paragraph (2)(a) through (h).
TRANSMITTER	TA, A	
VOLTAGE SELECTOR	48 V D. C. or 120 V D. C. (as unit to be tested is wired)	

Remaining switch positions are immaterial.

(2) To strobe the auxiliary contacts of the transmitter sensing shaft, the following procedure must be followed with the initial arrangement of the control switches as indicated above.

(a) The clutch of the sensing shaft must be disengaged by de-energizing the clutch magnet thru operation of the stop-run switch, the tight-tape switch, or the last character switch, whichever is applicable, to the unit under test. When testing the hardgate transmitter disengage the clutch of the sensing shaft, by turning off the test set power switch.

(b) Turn off the motor in the unit under test.

(c) Position the CL MAG switch to the DIST position.

(d) Restore the switch that was operated in paragraph (2)(a). Now the clutch magnet becomes energized.

(e) Turn on the motor in the unit under test.

(f) The test set will now display a trace of the distributor stop contact. Position the test scale so the stop pulse on the scale coincides with the stop pulse trace.

(g) Position the STROBE-ORIENT switch to the strobe position. The test set will now display the "A" auxiliary contact if the pull back transmitter is under test or the "Transmitter Auxiliary" auxiliary contact if the fixed or pivoted head transmitter are under test.

(h) To strobe the remaining auxiliary contacts, position the transmitter switch to the appropriate position. When strobing the code reading contacts of the pull back transmitter, it is necessary to feed a continuous loop of "Blank" and "Rub-out" tape thru the transmitter in order to obtain a measurement of contact closure. The eighth code level of the pull back transmitter will not display a trace when the test loop is used, but will display a trace when the test loop is removed.

e. STROBING EXTERNAL CONTACTS OPERATING AT 60, 75, 100 OR 200 WPM

(1) Position the control switches as follows:

<u>SWITCH</u>	<u>POSITION</u>
POWER	ON
PULSE	OFF
STROBE-ORIENT	STROBE
CL MAG	OFF
UNIT SELECTOR	EXT
VOLTAGE SELECTOR	48 V D. C. or 120 V D. C. (as unit to be tested is wired)

Remaining switch positions are immaterial.

(2) With the control switches positioned as above and the contact to be strobed plugged into the CONTACT INPUT jack the set will display the operation of the contact.

(3) With the control switches positioned as above and with no signal input, the test set will display a circular trace. This procedure can be used for checking the neon lamp.

f. STROBING THE LAK20 KEYBOARD CONTACTS

(1) Position the control switches as follows:

<u>SWITCH</u>	<u>POSITION</u>
POWER	ON
PULSE	OFF
STROBE-ORIENT	STROBE
CL MAG	OFF
UNIT SELECTOR	KYBD & REPERF
CONTACT SELECTOR	M

<u>SWITCH</u>	<u>POSITION</u>
KYBD PERF & REPERF	NO. 1
VOLTAGE SELECTOR	48 V D.C. or 120 V D.C. (as unit to be tested is wired)

Remaining switch positions are immaterial.

(2) Depressing the LTRS and REPT keys on the keyboard, the test set will display a trace of the No. 1 contact. Continue depressing the LTRS and REPT keys and rotate the keyboard perforator and reperforator switch, to strobe the remaining code contacts and the keyboard auxiliary contact. To strobe the letters contact pile-up, continue to depress the LTRS and REPT keys. Rotate the CONTACT SELECTOR switch to S and the KYBD PERF & REPERF switch to LTRS and the test set will display a trace of the "Letters" contact pile-up.

(3) To strobe the figures contact pile-up, the switches should remain as above except for the KYBD PERF & REPERF. These should be rotated to the FIGS position. The FIGS and REPT key should be depressed. The test set will display the spacing side of figures contact pile-up. Rotate the CONTACT SELECTOR switch to M to strobe the marking side of the figures contact pile-up.

g. STROBING REPERFORATOR CODE READING CONTACTS

(1) Position the control switches as follows:

<u>SWITCH</u>	<u>POSITION</u>
POWER	ON
PULSE	ON
STROBE-ORIENT	STROBE
CL MAG	OFF
UNIT SELECTOR	KYBD & REPERF
CONTACT SELECTOR	M
KYBD PERF & REPERF	NO. 1
VOLTAGE SELECTOR	48 V D.C. or 120 V D.C. (as units to be tested is wired)

Remaining switch positions are immaterial.

(2) With the above arrangement of switches the test set will display the No. 1 contact. To strobe the remaining contacts, turn the KYBD PERF & REPERF switch to the appropriate position.

(3) The selector of the reperforator under test will be pulsed at the correct speed by the internal pulser within the test set.

NOTE

Two cycle 200 WPM contacts are operated alternately by the two lobes of a double cycle cam. The selector (and double cycle cam) is pulsed once each revolution of the LSS202 code disc. During one revolution of the LSS202 code disc the contacts are operated by one lobe of the double cycle cam and during the next revolution they are operated by the other lobe of the double cycle cam. As seen on the LSS202 code disc, the two traces will be super-imposed. They will be half as long as the trace of contacts operating at 100 WPM.

h. STROBING PERFORATOR CODE READING CONTACTS OF THE ASR SET

(1) Position the control switches as follows:

<u>SWITCH</u>	<u>POSITION</u>
POWER	ON
PULSE	OFF
STROBE-ORIENT	STROBE
CL MAG	OFF
UNIT SELECTOR	KYBD & REPERF
CONTACT SELECTOR	M
KYBD PERF & REPERF	NO. 1
VOLTAGE SELECTOR	48 V D.C. or 120 V D.C. (as unit to be tested is wired)

Remaining switch positions are immaterial.

(2) Depress the LTRS and REPT keys of the ASR keyboard. The test set will display a trace of the No. 1 contact. Continue depressing the LTRS and REPT keys and rotate the KYBD

PERF & REPERF switch to strobe the remaining contacts.

(3) To accurately measure for closure of ASR code reading contacts, the ASR must be geared for 100 WPM. However, the 60 and 75 WPM speeds may be used to determine the general quality of the contact closure.

i. STROBING MULTI-MAGNET REPERFORATOR AUXILIARY CONTACTS

(1) Position the control switches as follows:

<u>SWITCH</u>	<u>POSITION</u>
POWER	ON
PULSE	OFF
STROBE-ORIENT	STROBE
CL MAG	OFF
UNIT SELECTOR	PERF
CONTACT SELECTOR	M
KYBD PERF & REPERF	A1
VOLTAGE SELECTOR	48 V D. C. or 120 V D. C. (as unit to be tested is wired)

Remaining switch positions are immaterial.

(2) Depress the LTRS and REPT keys. The test set will display a trace of the A1 contact. To strobe the remainder of the auxiliary contacts of the Multi-Magnet Reperforator, rotate the KYBD PERF & REPERF switch to the appropriate position.

j. MARGIN CHECK OF THE MULTI-MAGNET REPERFORATOR PUNCH SELECTOR MECHANISM

(1) Position the control switches as follows:

<u>SWITCH</u>	<u>POSITION</u>
POWER	ON
PULSE	OFF
STROBE-ORIENT	STROBE

<u>SWITCH</u>	<u>POSITION</u>
CL MAG	OFF
UNIT SELECTOR	PERF
CONTACT SELECTOR	M
KYBD PERF & REPERF	MAG
VOLTAGE SELECTOR	48 V D. C. or 120 V D. C. (as unit to be tested is wired)

Remaining switch positions are immaterial.

(2) Depressing the LTRS and REPT keys of the keyboard, the Multi-Magnet Reperforator will perforate all code levels (rub-out) if the punch selector mechanism has adequate operating margin. If a code level is not perforated, the particular punch selector mechanism should be investigated for excessive binds, broken parts or a defective selector magnet.

k. STROBING CODOMAT CODE READING CONTACTS

(1) Position the control switches as follows:

<u>SWITCH</u>	<u>POSITION</u>
POWER	ON
PULSE	OFF
STROBE-ORIENT	STROBE
CL MAG	OFF
UNIT SELECTOR	CODOMAT
CONTACT SELECTOR	M
CODOMAT AND DETECTOR	NO. 0
VOLTAGE SELECTOR	48 V D. C. or 120 V D. C. (as unit to be tested is wired)

Remaining switch positions are immaterial.

(2) The no-card contact pile-up must be shorted.

(3) With the control switches arranged as indicated above the test set will display the No. 0 contact. To strobe the remaining contacts rotate the CODOMAT & DETECTOR switch to the appropriate position.

1. CIRCUIT ASSURANCE CIRCUIT ADJUSTMENT

(1) Position the control switches as follows:

<u>SWITCH</u>	<u>POSITION</u>
POWER	ON
CODOMAT & DETECTOR	35 MS

Remaining switch positions are immaterial.

NOTE

The test set should not control the ASR rectifier.

(2) Install the two black test probes located in the control box into the Receive Line Relay Socket of the LESU57.

(3) With the control switches arranged as indicated above, the test set will generate a 35 MS spacing pulse. To generate a 65 MS spacing pulse rotate the CODOMAT & DETECTOR switch to the 65 MS position.

TABLE 4-1 SYSTEMS TROUBLE SHOOTING CHART

STEP	PRELIMINARY ACTION	NORMAL INDICATION	NEXT STEP
1.	Set power "ON-OFF" switch to its "ON" position. (AC plug attached to 115 volt 60 cycle source).	Disk and lamp arm should rotate.	If no action is obtained, check fuse located on Mounting Bracket
	With Control Switches positioned as follows: Power ON Pulse OFF	The Neon Lamp should display a continuous trace.	If lamp does not glow turn off power switch and replace lamp with spare lamp stored in socket attached to cord compartment. Inspect the slip rings on hub assembly.
2.	Strobe - Orient STROBE Cl Mag OFF Selector DIST. Perf. - Strobe T-D T-D - Strobe OFF		
3.	With Control Switches positioned as in step 2 except the pulse switch which is in its "ON" position.	Closure of the pulser contact will be displayed on the scale. (40-55 DIV)	Clean and burnish contacts, if image is erratic. Adjust contacts if timing is incorrect - see Fig. 5-6.
4.	With Connector attached to Transmitter Distributor and Test Set control switches positioned to accept either the Fixed or Pivoted Head Transmitter. (Operate "CL MAG" SW. to SENSE or DIST. POS.)	Clutch magnet should operate.	If magnet is not energized, check fuse in 120 volt D.C. output of rectifier.
5.	With Control Switches positioned to view individual contacts. (Cables attached to unit).	Stationary band of light should be visible.	If trace of respective contact does not remain stationary, check speed setting. (W.P.M.)
	With cables connected to specific contacts to be "strobed".	Image should be visible and synchronized.	Check position of each control switch. Avoid unmarked positions of Perf. Strobe Switch.

SECTION 4

TROUBLE SHOOTING

1. GENERAL

Troubleshooting is a maintenance procedure based upon a visual inspection, overall trouble shooting and functional section - trouble shooting. This routine is calculated to minimize unwanted interruptions of service and to provide a means of locating and clearing trouble when it occurs.

a. Visual Inspection - Visual observation and past performance often provides an early indication of impending trouble. The correction of a minor fault observed during a routine maintenance check may eliminate major repairs and prevent a shut down of the equipment. The suggested approach is as follows:

(1) FEELING This technique is used on rotating mechanisms and on electrical components to detect an abnormal temperature rise. The warning may be the result of an overload caused by a lack of lubrication, misalignment, faulty connectors etc. Since the equipment may be operated in a high ambient temperature, care must be exercised in determining an overheated condition.

(2) LISTENING Excessive vibration, bearing noise, and arcing of electrical contacts represents the auditory observation that should be noted when the unit is in operation. Bear in mind that gear noises should not be mistaken on faulty bearings.

(3) INSPECTING This action is relied upon to note the state of cleanliness, the amount of wear, dirty contacts, mechanisms that bind, distorted springs, or worn cables. The procedure should include a check for the correct position of all control switches and levers, defective indicator lamps, open fuses, etc.

2. OVERALL TROUBLE SHOOTING

a. Preliminary Checks --- Inspect the cables and connectors for loose leads, dirty contacts and damaged insulation. Clean and burnish the slip rings when necessary. Exercise care in cleaning to prevent damage or misalignment of the brush springs. Make sure that the position of each control switch is in

agreement with the set-up outlined in Section 3 for the particular unit to be strobed.

b. In addition to the tools listed in Teletype Bulletin 1124B, an ohmmeter or an assembly for "lamping out" a circuit is required to check continuity. It is not expected that periodic voltage measurements of the rectifier output will be required. However, access to D.C. Voltmeter with a range for the 120 Volt and 240 Volt output should facilitate a study and analysis of the switch and circuit combinations that may be set up.

c. Refer to Table 4-1 for symptoms and a possible source of trouble.

3. FUNCTIONAL SECTION - TROUBLE SHOOTING

a. Preliminary Check -- Make sure that all soldered connections are tight and free of corrosion. The wiring should not interfere with moving parts of the set and all moving parts should be free of binds. The speed of the Test Set must coincide with the unit being "strobed" except for the 200 W.P.M. application.

b. Test Equipment -- The following test is based upon the use of a Signal Distortion Test Set - DXD. This instrument generates a signal which is used as a standard. With the DXD connected to the Stroboscopic Test Set, the image displayed on the calibrated scale may be compared with the pattern displayed on the DXD.

c. Testing

(1) Plug the output of the Signal Distortion Test Set - DXD into the signal jack. Transmit the letter "R" into the Test Set and compare the pulse lengths with the pulse lengths displayed on the DXD scale. The transition points indicated on the scale of the Stroboscopic Test Set should be within plus or minus 2 divisions of the comparable pulse viewed on the DXD.

(2) Check the function of each control switch by strobing the actual contacts on the respective units.

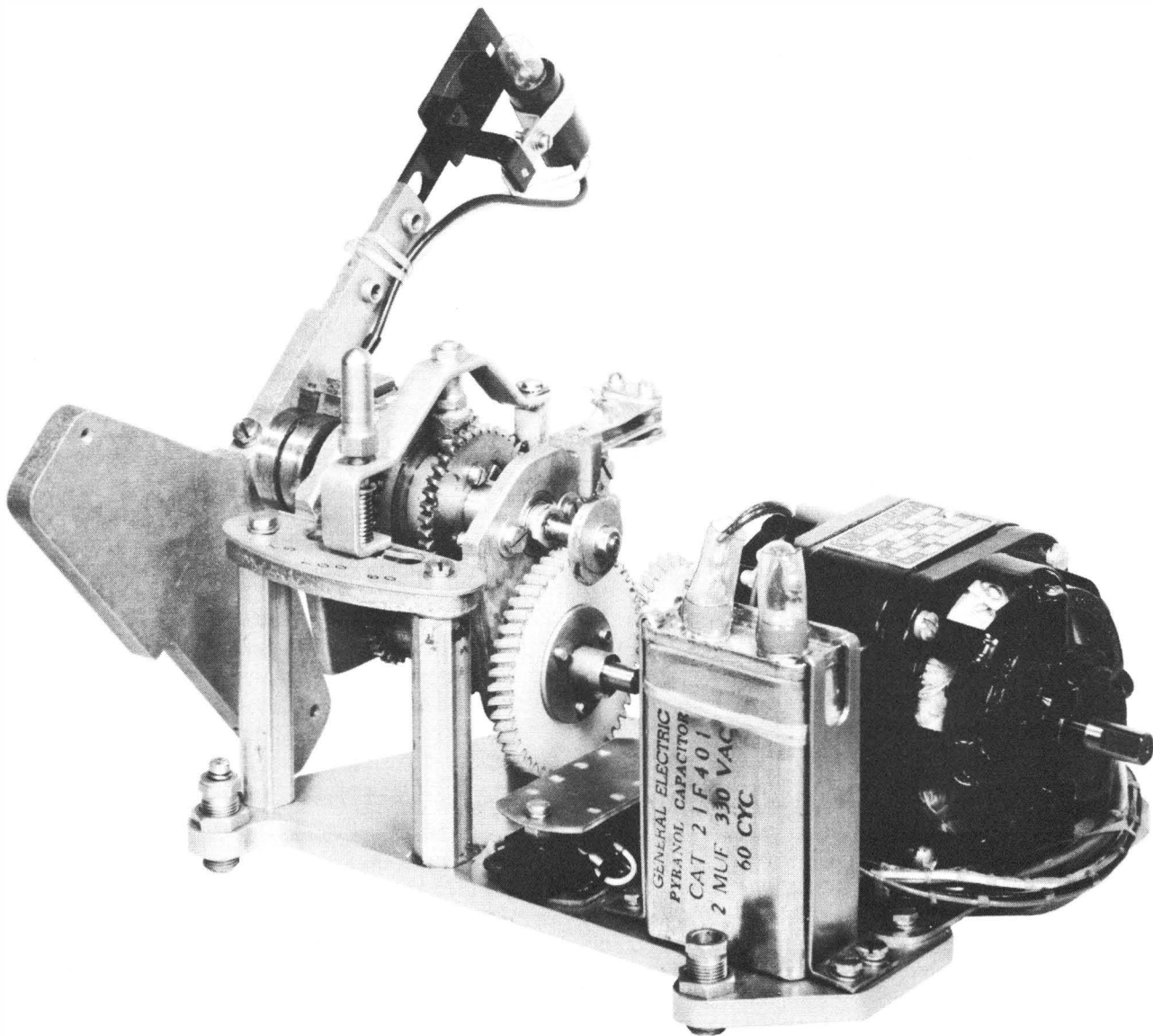

FIGURE 5-1 NEON LAMP, ARM AND DRIVE MECHANISM

SECTION 5

MAINTENANCE

1. GENERAL

a. The rear door of the Stroboscopic Test Set may be opened for inspection, lubrication, and minor repairs of the unit. However, the neon lamp, slip rings, and slip ring brushes are more accessible for servicing when the rotating disk is removed. The disk is secured by three countersunk screws located on the front.

b. A periodic visual inspection with regard to wear, alignment, lubrication and cleanliness of the mechanisms should detect an imminent source of trouble. Refer to the Trouble Shooting section for the suggested approach.

2. ASSEMBLY AND DISASSEMBLY

a. When more extensive maintenance is to be made, all cables should be disconnected from their receptacles and the rotating disk removed if it has not been removed previously.

b. The motor and gear shift mechanism are supported by a common base plate with four bushings to vary the height of the entire assembly. Note the screw that is placed through each bushing to clamp the assembly to its subbase. Remove each screw in accordance with the instructions on page 5-2. A generous length of cable is provided which will enable some movement of the assembly as it is tipped and moved through the opening in the front panel. However, the cable should be disconnected from its terminal block to provide more freedom of movement and prevent damage to the cable. Remove the two screws that secure the guard to the terminal block and then remove the terminal screws. Replace the assembly in the reverse order.

c. For a further disassembly of each component, refer to the exploded view of the mechanism shown in Section 6. The correct relationship of each part is shown with the screws or means of securing the part to the major component of the mechanism.

Retaining rings (tru-arc) are made of spring steel and have a tendency to release suddenly. Loss of the rings may be minimized as follows: Hold the ring with the left hand to prevent it from rotating. Place the blade of a suitable screwdriver in one of the slots of the ring. Rotate the screwdriver in a direction to increase the diameter of the ring. The retaining ring

will come off readily without flying.

3. TOOLS AND SPRING SCALES

To facilitate the disassembly and adjustment of the Test Set, refer to the tools arranged for maintenance purposes in the Teletype Bulletin 1124B. The tools are not furnished as part of the equipment.

4. ADJUSTMENTS

a. The adjustment of the Stroboscopic Test Set is arranged in a sequence that should be followed if a complete readjustment of the unit were undertaken.

b. After an adjustment has been completed, be sure to tighten any nuts or screws that have been loosened.

c. The adjusting illustrations, in addition to indicating the adjusting tolerances, positions of moving parts and spring tensions, also show the angle at which the scale should be applied when measuring spring tensions.

d. From time to time the requirements and procedures for the various adjustments may be changed. For this reason, the text of the adjustment in the latest issue should be read through before proceeding to make any readjustment.

e. If parts or assemblies are removed to facilitate readjustment and subsequently replaced, recheck any adjustment that may have been affected by the removal of these parts or assemblies.

f. The spring tensions given in this bulletin are indications (not exact values) and should be checked with proper spring scales in the position indicated. Springs which do not meet the requirement and for which no adjusting procedure is given should be replaced by a new spring.

g. Reference made to left or right, up or down, front or rear etc. apply to the unit in its normal operating position as viewed from the operators position opposite the end with the motor.

h. All contact points should meet squarely. Contacts with the same diameter should not be out of alignment more than 25% of the contact diameter. Avoid sharp kinks or bends in the contact springs.

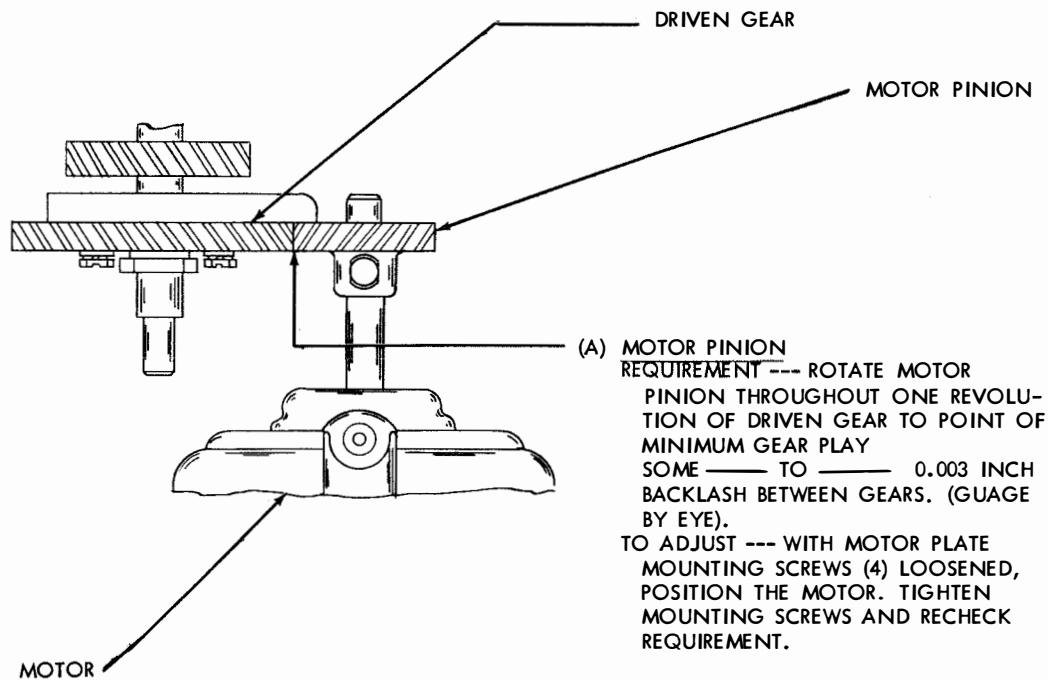

REFER TO BASE PLATE ASSEMBLY FIG. 2-3

INSTRUCTIONS FOR

REMOVING THE BASE PLATE ASSEMBLY

NOTE --- THIS PLATE CONTAINS THE

MOTOR, GEAR SHIFT ASSEMBLY AND HUB WITH SLIP RINGS AND LAMP ARM. THE PLATE IS SECURED TO THE BRACKET BY A SCREW LOCATED WITHIN EACH OF THE FOUR ADJUSTING BUSHINGS.

- (1) REMOVE THE SCREWS (3) THAT SECURE THE ROTATING DISK TO THE HUB AND LIFT THE DISK FORWARD.
- (2) REMOVE THE SCREW WITHIN EACH OF THE FOUR ADJUSTING BUSHINGS. DO NOT DISTURB THE LOCATING ECCENTRICS WHICH SERVE AS A GUIDE WHEN THE PLATE IS REPLACED. DISCONNECT THE CABLE IF REQUIRED.
- (3) LIFT THE ASSEMBLY UPWARD AND TILT SLIGHTLY SO THAT LAMP ARM CLEARS THE OPENING IN THE CABINET.

FIGURE 5-2 MOTOR PINION

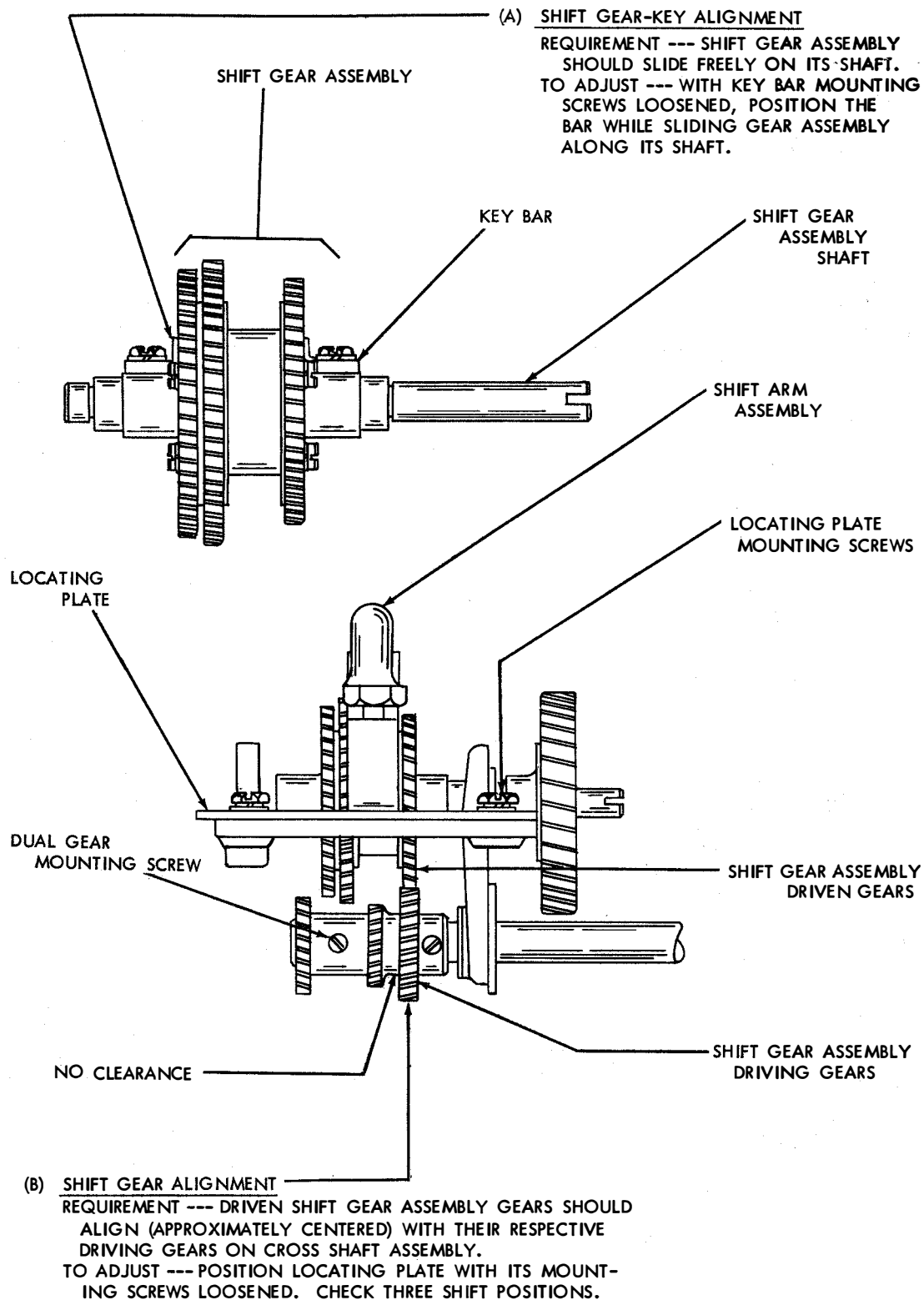

NOTE --- MAKE CERTAIN THAT THE TWO PORTIONS OF THE SHIFT GEARS ON THE CROSS SHAFT ASSEMBLY ARE MOUNTED WITH NO CLEARANCE BETWEEN THEM. IF THERE IS CLEARANCE, LOOSEN DUAL GEAR MOUNTING SCREW AND ELIMINATE CLEARANCE BEFORE MAKING ABOVE ADJUSTMENT.

FIGURE 5-3 GEAR SHIFT MECHANISM

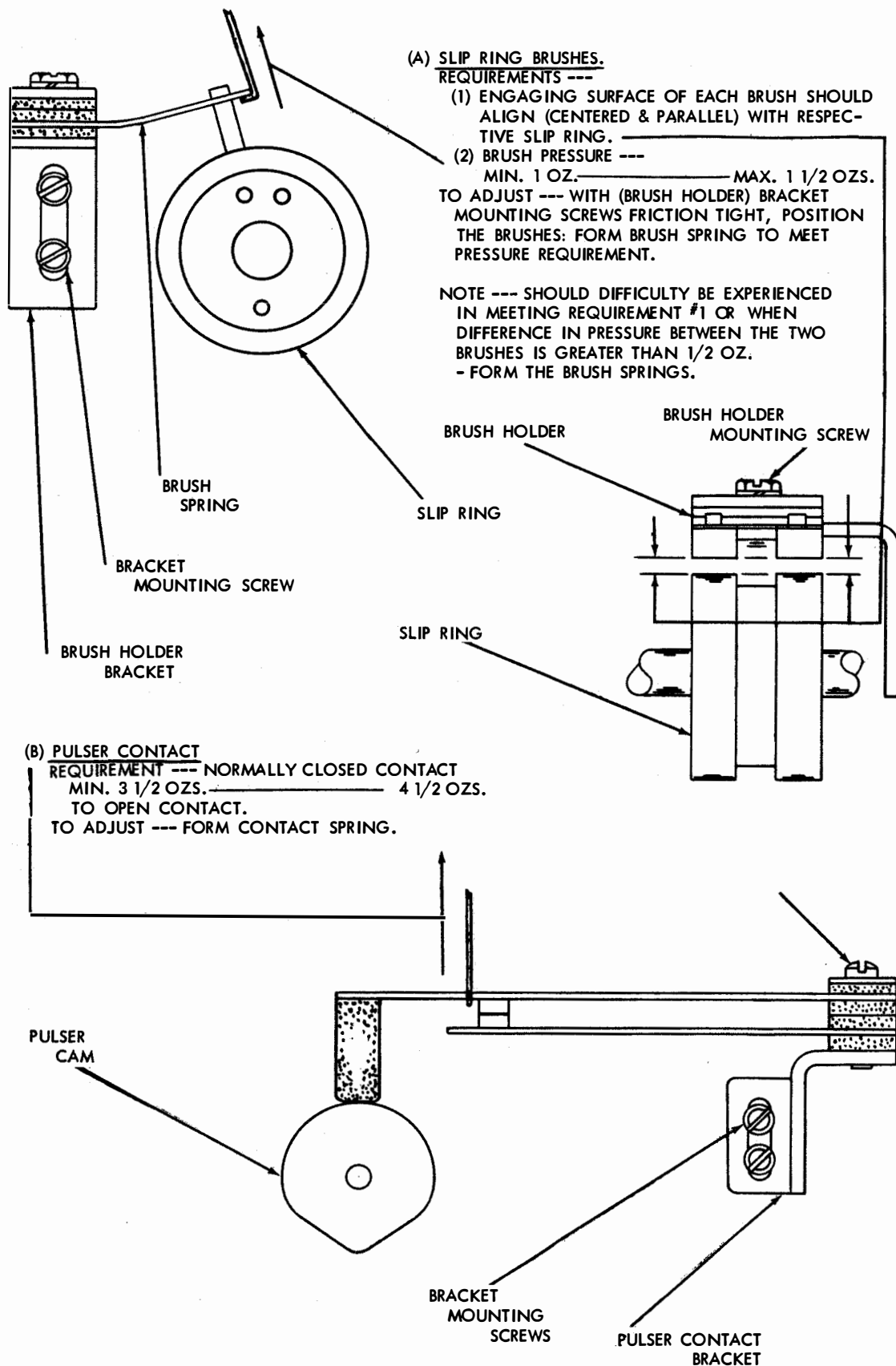

FIGURE 5-4 SLIP RING ASSEMBLY AND PULSER CONTACTS

(B) BASE PLATE ADJUSTMENT
REQUIREMENTS ---

- (1) PLANE OF REVOLVING DISK SHOULD COINCIDE WITH PLANE OF SCALE ON FRONT PANEL (FLUSH AS GAUGED BY EYE).
- (2) DISK SHOULD BE CENTRALLY LOCATED WITHIN THE OPENING OF THE SCALE AND SHOULD ROTATE FREELY.

TO ADJUST --- WITH ITS LOCK NUT LOOSENED, POSITION ADJUSTING BUSHING SO THAT CLEARANCE BETWEEN BASE PLATE AND THE BRACKET IS APPROXIMATELY 1/4 INCH. CENTRALLY LOCATE BRACKET MOUNTING SCREWS IN THE ELONGATED MOUNTING HOLES. LOOSEN ECCENTRIC POST MOUNTING SCREWS. POSITION THE 161186 GUIDE BUSHINGS IN THEIR ENLARGED MOUNTING HOLES SO THAT THE 92397 SCALE IS APPROXIMATELY CENTERED IN THE COVER OPENING. AFTER TIGHTENING THE BUSHING MOUNTING SCREWS CHECK TO SEE THAT THE SCALE IS FREE TO ROTATE WITH A MINIMUM AMOUNT OF SIDE PLAY. WITH BASE-PLATE AND GEAR ASSEMBLY PLACED ON BRACKET (MOUNTING SCREWS FRICTION TIGHT) POSITION BASE PLATE TO MEET ABOVE REQUIREMENTS. MOVE FRONT PAIR OF BUSHINGS UP OR DOWN AND/OR THE REAR PAIR OF BUSHINGS UP OR DOWN BY THE SAME AMOUNT FOR VERTICAL ALIGNMENT. SHIFT BASE TOWARD RIGHT, LEFT, OR FORWARD (BY AMOUNT OF OVER SIZE MOUNTING HOLES) TO ALIGN HORIZONTALLY. SHOULD GREATER HORIZONTAL OR FORWARD ADJUSTMENT BE REQUIRED REPOSITION THE BRACKET. TURN THREE ECCENTRIC POSTS AGAINST BASE PLATE AND TIGHTEN ALL SCREWS AND NUTS.

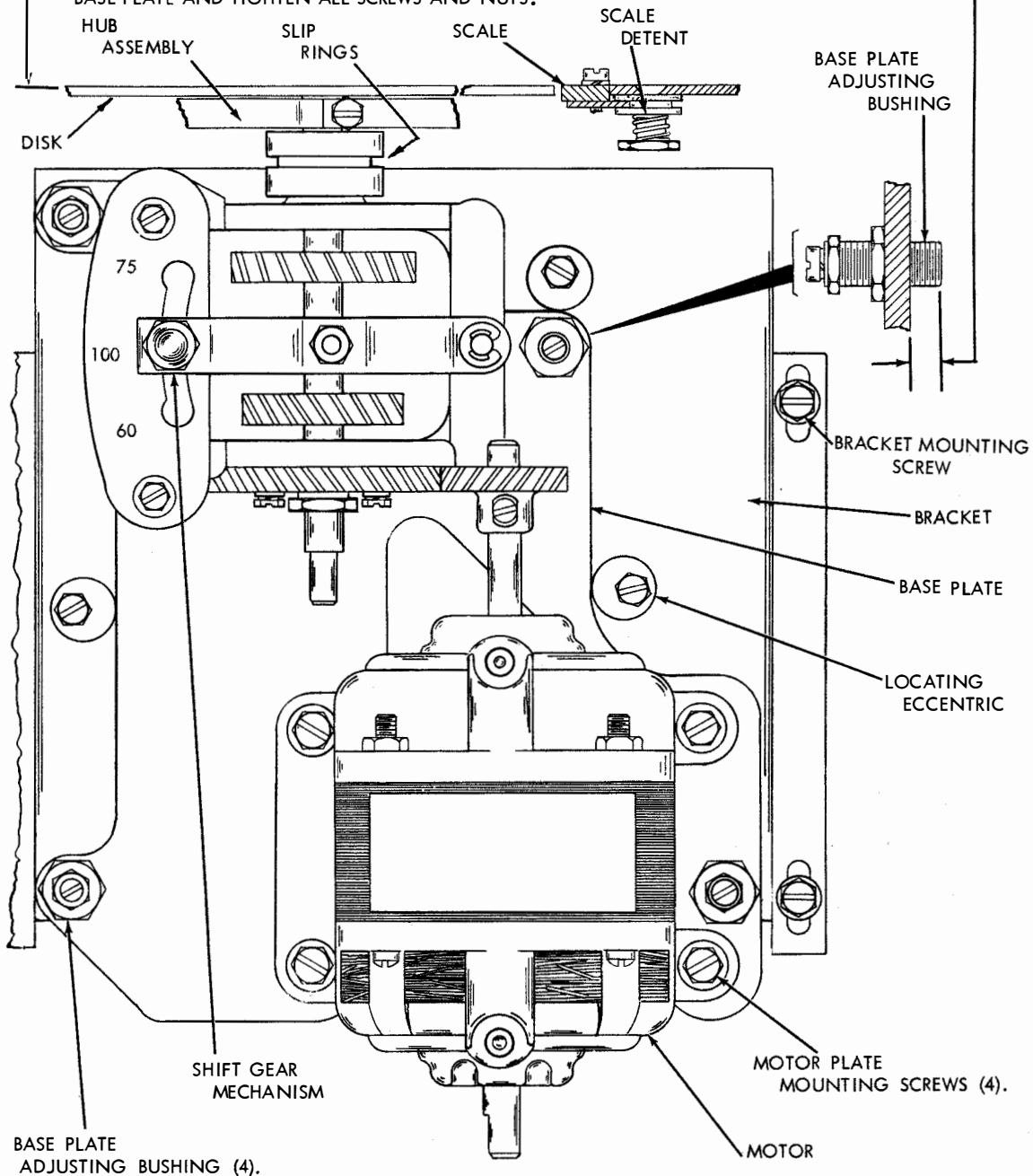

FIGURE 5-5 BASE PLATE ASSEMBLY

(A) NEON LAMP ARM

REQUIREMENT --- CLEARANCE BETWEEN TOP EDGE OF LAMP ARM (SLOTTED PORTION) AND INNER DIAMETER OF SCALE SOME _____ TO _____ 0.010 INCH

NOTE: ROTATE DISK AND SCALE SIMULTANEOUSLY TO ASSURE A CLEARANCE OVER 360° OF TRAVEL.

TO ADJUST --- WITH DISK REMOVED AND ARM MOUNTING BUSHINGS (2) FRICTION TIGHT, REVOLVE ARM AND SCALE TO FIND POINT WHERE ARM JUST TOUCHES SCALE. POSITION ARM FOR CLEARANCE, RETIGHTEN SCREWS AND RECHECK REQUIREMENT.

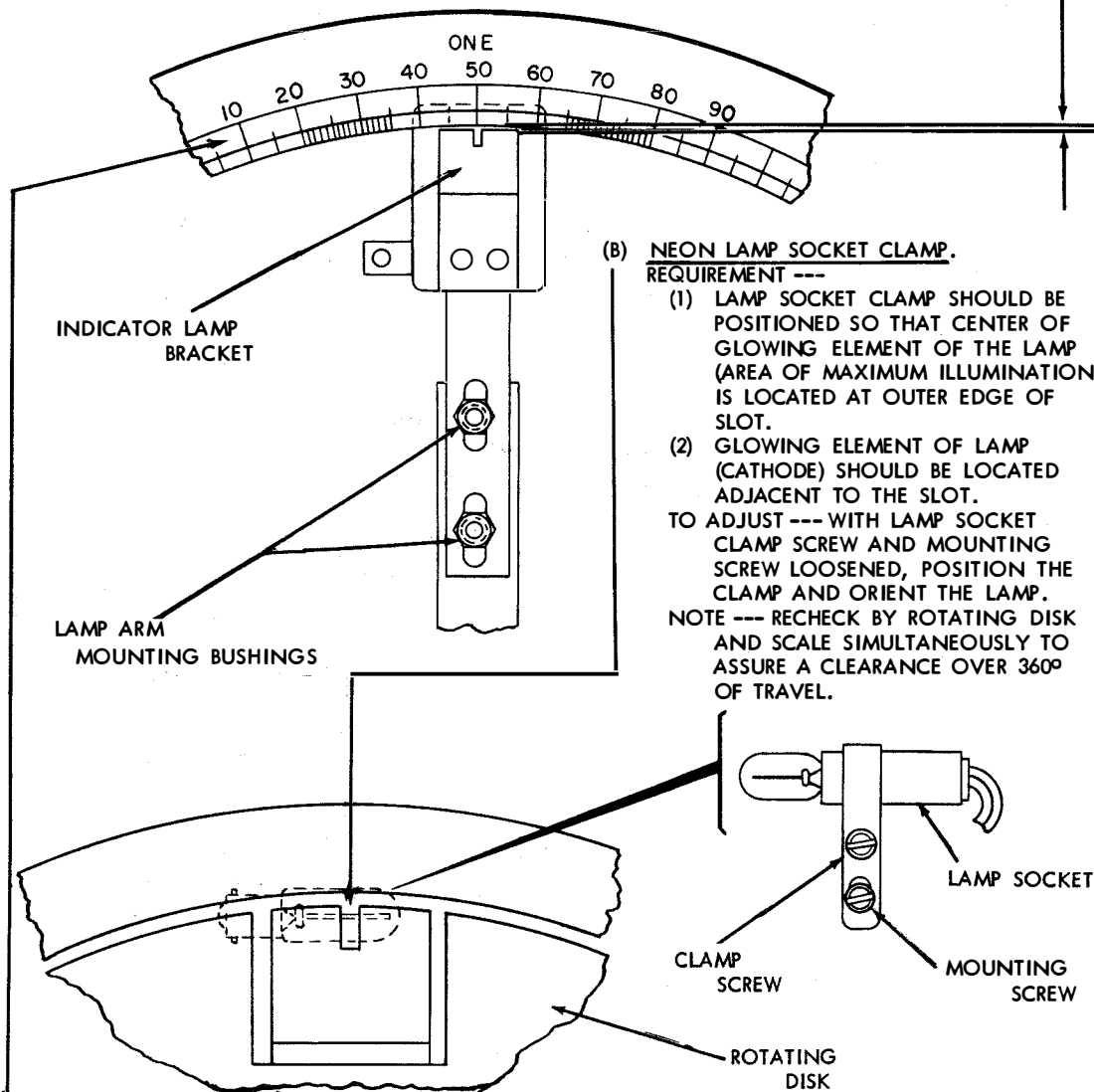
**(B) NEON LAMP SOCKET CLAMP.**

REQUIREMENT ---

- (1) LAMP SOCKET CLAMP SHOULD BE POSITIONED SO THAT CENTER OF GLOWING ELEMENT OF THE LAMP (AREA OF MAXIMUM ILLUMINATION) IS LOCATED AT OUTER EDGE OF SLOT.
- (2) GLOWING ELEMENT OF LAMP (CATHODE) SHOULD BE LOCATED ADJACENT TO THE SLOT.

TO ADJUST --- WITH LAMP SOCKET CLAMP SCREW AND MOUNTING SCREW LOOSENED, POSITION THE CLAMP AND ORIENT THE LAMP.

NOTE --- RECHECK BY ROTATING DISK AND SCALE SIMULTANEOUSLY TO ASSURE A CLEARANCE OVER 360° OF TRAVEL.

(C) PULSER CONTACTS

REQUIREMENT --- WITH UNIT CONNECTED TO A 115 VOLT A.C. POWER SOURCE, PLACE ALL SWITCHES IN UPPER RIGHT CORNER OF FRONT PANEL IN THEIR "OFF" POSITION, THE "STROBE-ORIENT" SWITCH IN THE "STROBE" POSITION AND THE PULSER SWITCH IN ITS "ON" POSITION. TURN POWER SWITCH "ON" AND OBSERVE THE TRACE OF THE NEON LAMP. PULSER CONTACTS (SEE FIG. 2-3) SHOULD BE OPENED ONCE DURING EACH REVOLUTION OF THE DISK.

MIN. 40 SCALE DIVISIONS _____ MAX. 55 SCALE DIVISIONS

TO ADJUST --- TURN THE POWER SWITCH OFF AND LOOSEN PULSER CONTACT BRACKET MOUNTING SCREWS. MOVE CONTACT CLOSER TO CAM IF PULSE IS TOO SHORT. MOVE CONTACT AWAY FROM CAM IF PULSE IS TOO LONG. RECHECK REQUIREMENT AFTER SCREWS ARE TIGHTENED.

FIGURE 5-6 NEON LAMP AND BRACKET ASSEMBLY

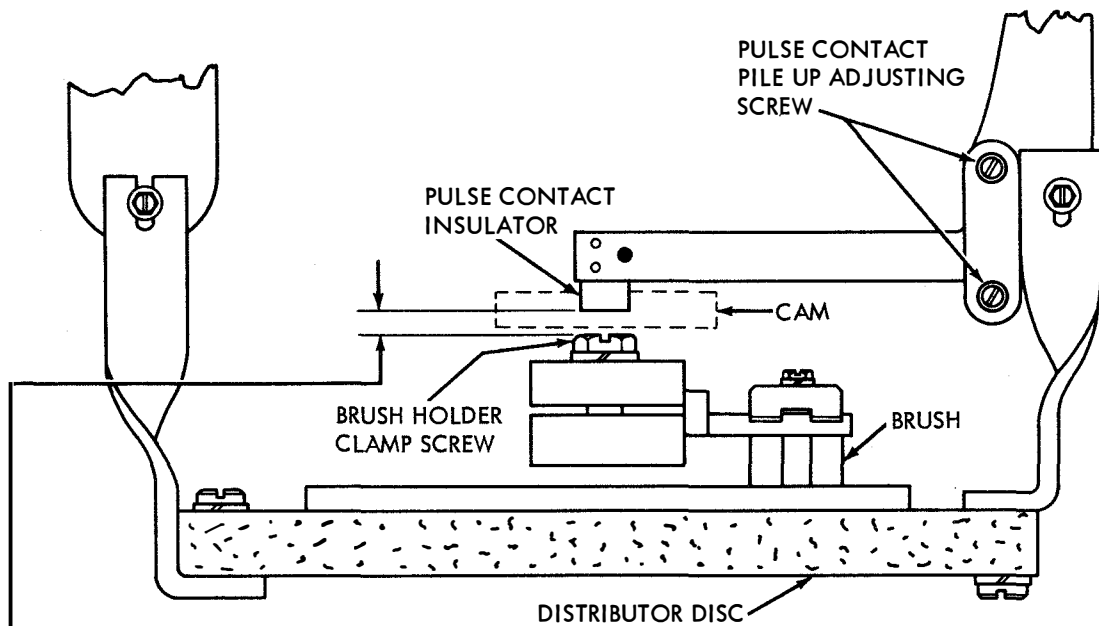

**PULSER ADJUSTMENT
REQUIREMENTS ---**

- (1) PULSER CONTACT SHALL OPEN 40 TO 55 DIVISIONS DURING EACH REVOLUTION.
- (2) BRUSH HOLDER CLAMP SCREW SHALL CLEAR PULSE CONTACT INSULATOR BY A MINIMUM OF .010.

TO ADJUST

- (1) CONNECT UNIT TO 110 V A.C. ALL SWITCHES SHOULD BE IN THE "OFF" POSITION. PULSER SWITCH SHOULD BE "ON". PLACE UNIT SELECTOR SWITCH IN THE "EXTERNAL" POSITION. INSERT PHONE PLUG TEST CORD INTO "CONTACT INPUT JACK". PUT PHONE TEST CORD LEADS ACROSS PULSER CONTACT PILE UP. TURN ON POWER AND READ CONTACT OPEN TIME ON SCALE. TURN OFF POWER AND LOOSEN PULSER CONTACT BRACKET SCREWS AND ADJUST. (SEE FIGURE 5-4) MOVE CONTACT CLOSER TO CAM IF PULSE IS TOO SHORT, MOVE CONTACT AWAY FROM CAM IF PULSE IS TOO LONG. TIGHTEN BRACKET AND REPEAT ABOVE, UNTIL REQUIREMENT ONE IS MET.
- (2) POSITION PULSE CONTACT PILE-UP TO OBTAIN CLEARANCE FOR REQUIREMENT TWO.

FIGURE 5-7. PULSER ASSEMBLY

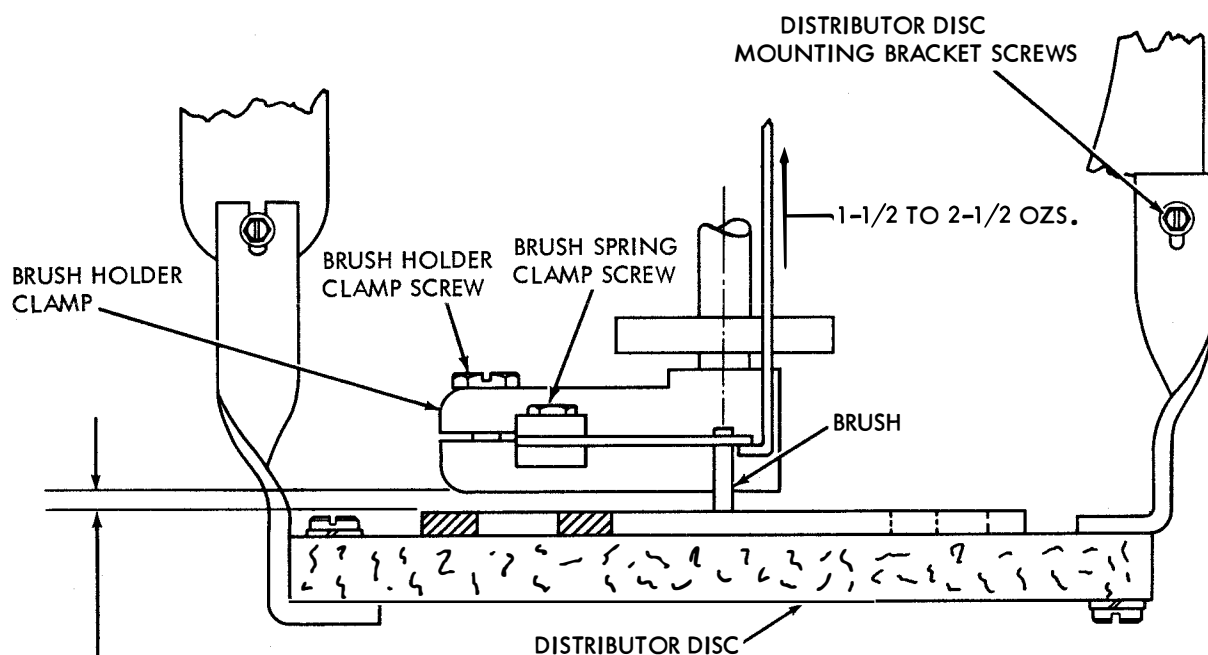

DISTRIBUTOR DISC ADJUSTMENT
REQUIREMENT

CLEARANCE SHALL BE .045 TO .055 BETWEEN BRUSH HOLDER CLAMP AND INNER COMMUTATOR RING.

TO ADJUST

LOOSEN TWO DISTRIBUTOR DISC MOUNTING BRACKET SCREWS FRICTION TIGHT. POSITION DISC ON CASTING TO MEET REQUIREMENTS. TIGHTEN SCREWS.

DISTRIBUTOR BRUSH SPRING

REQUIREMENT

HOOK 8 OZ. SCALE UNDER END OF EACH DISTRIBUTOR BRUSH SPRING. PULL AT RIGHT ANGLES TO END OF BRUSH SPRING. MIN. 1-1/2 OZS. MAX. 2-1/2 OZS. TO LIFT BRUSH FROM ITS SEGMENT. TO DETERMINE THIS POINT, USE A TEST LAMP.

TO ADJUST

WITH BRUSH HOLDER CLAMP SCREW FRICTION TIGHT ROTATE BRUSH HOLDER COUNTERCLOCKWISE UNTIL BRUSHES ARE LIFTED FROM THEIR SEGMENTS. ADJUST BRUSH SPRINGS BY BENDING THEM SLIGHTLY (IF NECESSARY) SO THAT CONTACT SURFACE OF BRUSHES ARE EQUIDISTANT FROM AND PARALLEL TO THE SEGMENTS. ROTATE BRUSH HOLDER CLOCKWISE UNTIL BRUSHES REST AGAINST SEGMENTS WITH A PRESSURE OF ABOUT 2-1/2 OZS. TIGHTEN CLAMP SCREW. PLACE A PIECE OF FINE SAND PAPER (APPROXIMATELY 1" WIDE) FACE UP ON DISTRIBUTOR DISC AND DRAW BRUSHES ACROSS IT TWO OR THREE TIMES OR UNTIL BOTTOMS OF BRUSHES ARE PARALLEL TO SURFACE OF SEGMENTS. RECHECK SPRING TENSION. READJUST IF IT DOES NOT MEET THE ABOVE REQUIREMENTS. IF NECESSARY TO READJUST BRUSH HOLDER TO OBTAIN PROPER SPRING TENSION, BRUSHES SHOULD BE RESURFACED IN ACCORDANCE WITH FOREGOING INSTRUCTIONS. WHEN BRUSHES ARE ROTATED THRU ONE REVOLUTION BRUSH CLAMP MUST CLEAR INTERMEDIATE SHAFT OF GEAR SHIFT ASSEMBLY. IF NECESSARY TO MEET THIS REQUIREMENT READJUST BRUSH SPRINGS IN ACCORDANCE WITH THE ABOVE INSTRUCTIONS.

FIGURE 5-8. DISTRIBUTOR DISC ASSEMBLY

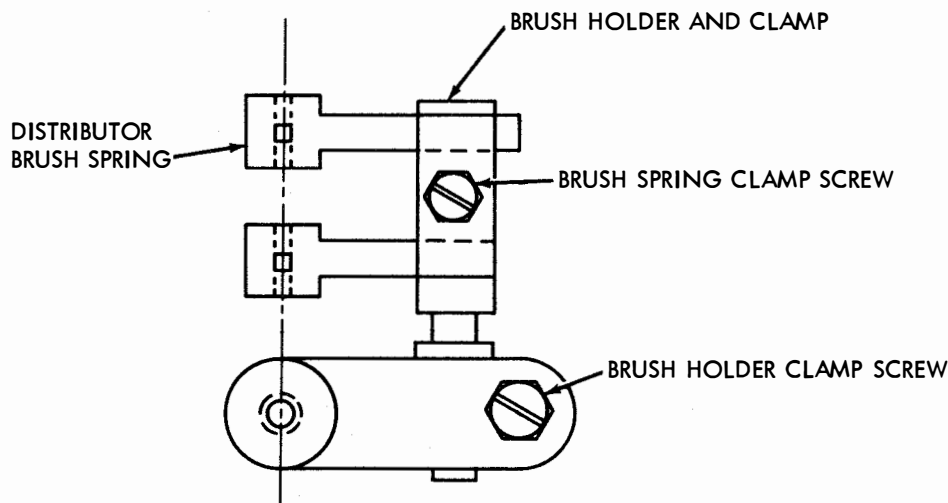

CARBON BRUSH ADJUSTMENT FOR 35MS., 65MS. DISTRIBUTOR DISC
REQUIREMENTS

- (1) CARBON BRUSHES SHOULD BE IN LINE WITH CENTER OF SHAFT ON WHICH BRUSH HOLDER IS MOUNTED.
- (2) BRUSHES SHOULD REMAIN WITHIN THE EDGES OF THE RINGS THROUGHOUT A COMPLETE REVOLUTION OF THE BRUSH SHAFT.
- (3) WITH CONTROL SWITCHES ARRANGED AS COVERED IN SECTION 3 PARAGRAPH 4.d. AND THE CODOMAT DETECTOR SWITCH ON POSITION 35MS, INSERT PHONE PLUG TEST CORD INTO SIGNAL INPUT JACK. CONNECT LEADS FROM TEST CORD TO "BLACK" JACKETED TEST PROBES LOCATED IN REAR OF CONTROL BOX. TEST SET MUST DISPLAY A SPACING TRACE OF 260 ± 5 SCALE DIVISIONS. MOVE CODOMAT AND DETECTOR SWITCH TO 65MS. TEST SET MUST DISPLAY A SPACING TRACE OF 482 ± 5 SCALE DIVISIONS.

TO ADJUST

- (1) LOOSEN BRUSH SPRING CLAMP SCREW AND POSITION BRUSHES. TIGHTEN CLAMP SCREW SO THAT BRUSH SPRINGS ARE FRICTION TIGHT.
- (2) LOOSEN BRUSH HOLDER CLAMP SCREW AND POSITION BRUSH HOLDER. UTILIZE THE PLAY OF BRUSH SPRINGS IN THEIR SLOTS TO POSITION SPRINGS SIDWAYS. TIGHTEN CLAMP SCREWS.
- (3) TO MEET REQUIREMENT 3 REFINE ADJUSTMENTS 1 AND 2.

FIGURE 5-9. DISTRIBUTOR DISC ASSEMBLY

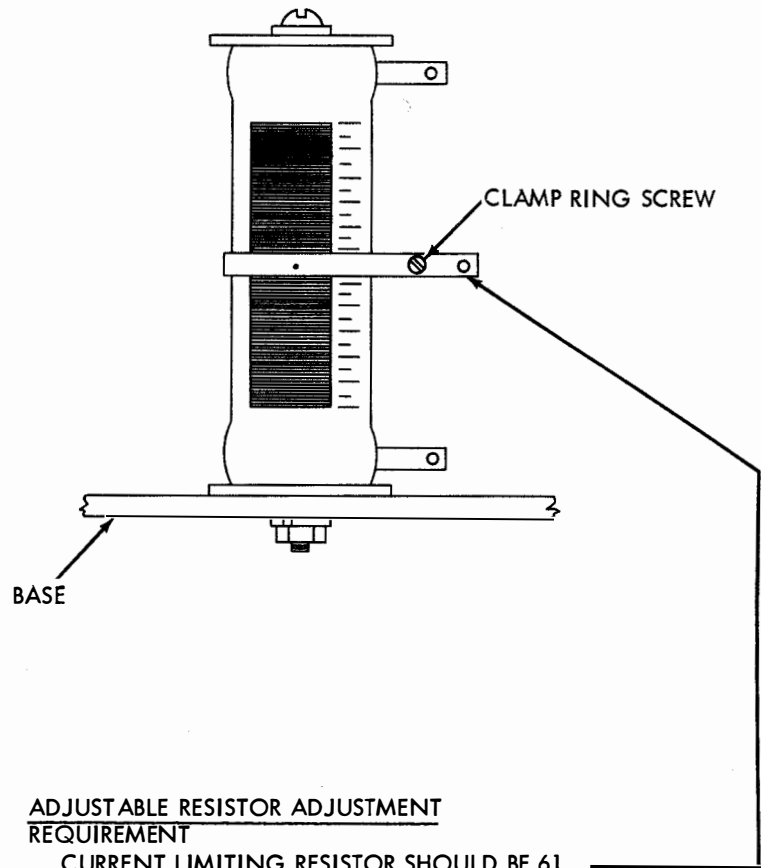

ADJUSTABLE RESISTOR ADJUSTMENT
REQUIREMENT

CURRENT LIMITING RESISTOR SHOULD BE 61
OHMS \pm 5%

TO ADJUST

REMOVE CONTROL BOX ASSEMBLY FROM STROBOSCOPIC LAMP CABINET. LOOSEN CLAMP RING SCREW. POSITION RING TO OBTAIN 61 OHMS RESISTANCE. CHECK RESISTANCE WITH OHMMETER. TIGHTEN CLAMP RING SCREW. TAKE CARE NOT TO TIGHTEN SCREW TOO HARD AS THERE IS DANGER OF BREAKING RESISTOR.

FIGURE 5-10. ADJUSTABLE RESISTOR

LUBRICATION

1. GENERAL

1.01 The Stroboscopic Test Set should be lubricated before being stored or placed in service. After a few weeks of service, relubricate to make certain that all points of each mechanism receive lubrication. The following lubrication schedule should be followed thereafter:

OPERATING SPEED	LUBRICATION INTERVAL
60 WPM	1,000 Hours or 6 Months*
75 WPM	
100 WPM	

*Whichever occurs first.

1.02 KS7470 oil should be used for lubrication of all points where oil is specified. KS7471 grease should be used at all points where grease is specified. All felt lubricating washers and all moving surfaces should be thoroughly lubricated. However, over lubrication which would allow oil to drip or grease to be thrown on other parts should be avoided. Exercise the utmost care to

avoid getting oil or grease on the face of any contact point.

1.03 Should the motor be disassembled at any time, replenish oil lost from bearings by bleeding.

1.04 The detenting feature for the calibrated scale provides a snubbing action to prevent accidental shifting of the scale position. It also provides an easy movement of the scale over 360° of travel when it is shifted manually. The Nylatron bushing should be lubricated periodically.

1.05 The photographs show the paragraph numbers referring to particular line drawings of mechanisms and where these mechanisms are located on the unit.

1.06 The illustration symbols indicate the following lubrication directions:

- O Apply 1 drop of oil.
- O2 Apply 2 drops of oil.
- O3 Apply 3 drops of oil.
- G Apply thin film of grease.
- SAT Saturate (Felt Washers, Wicks) with oil.

2. DRIVE MECHANISM

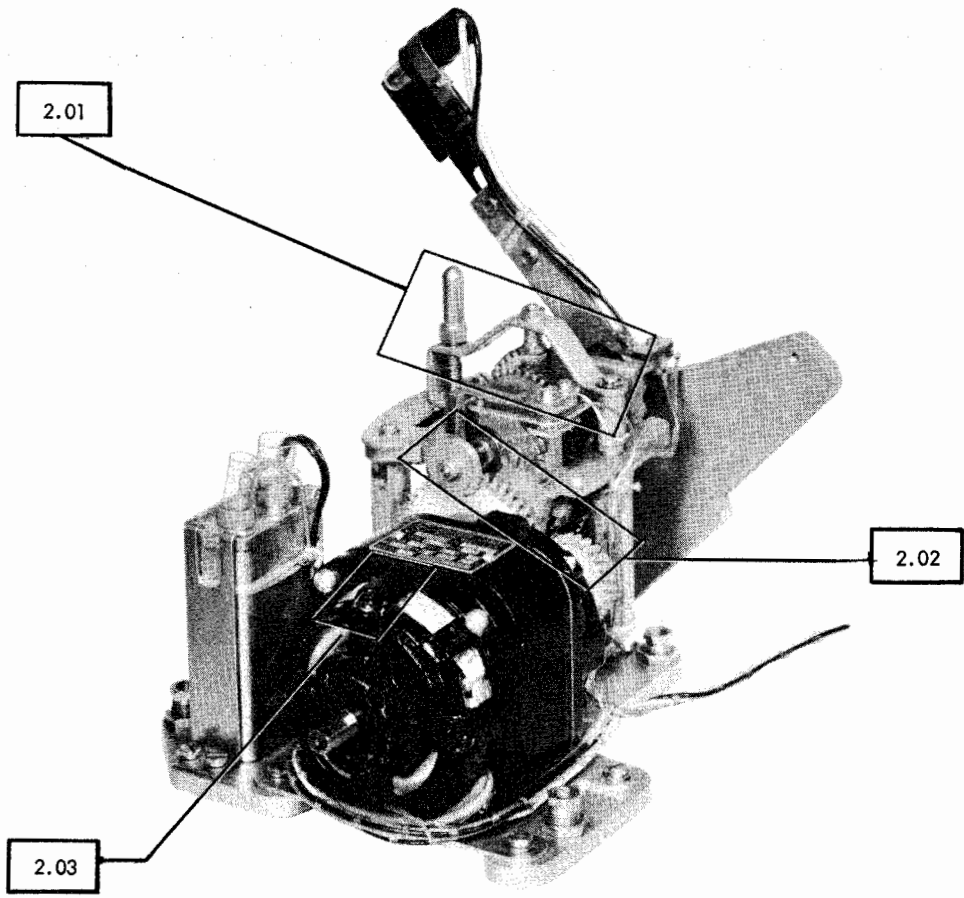
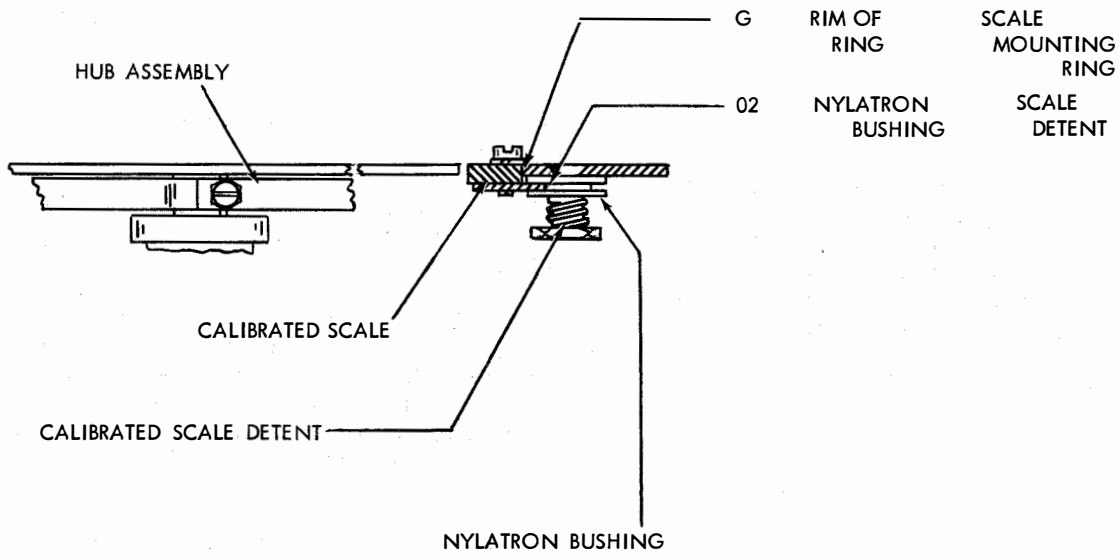

2.01 GEAR SHIFT ASSEMBLY

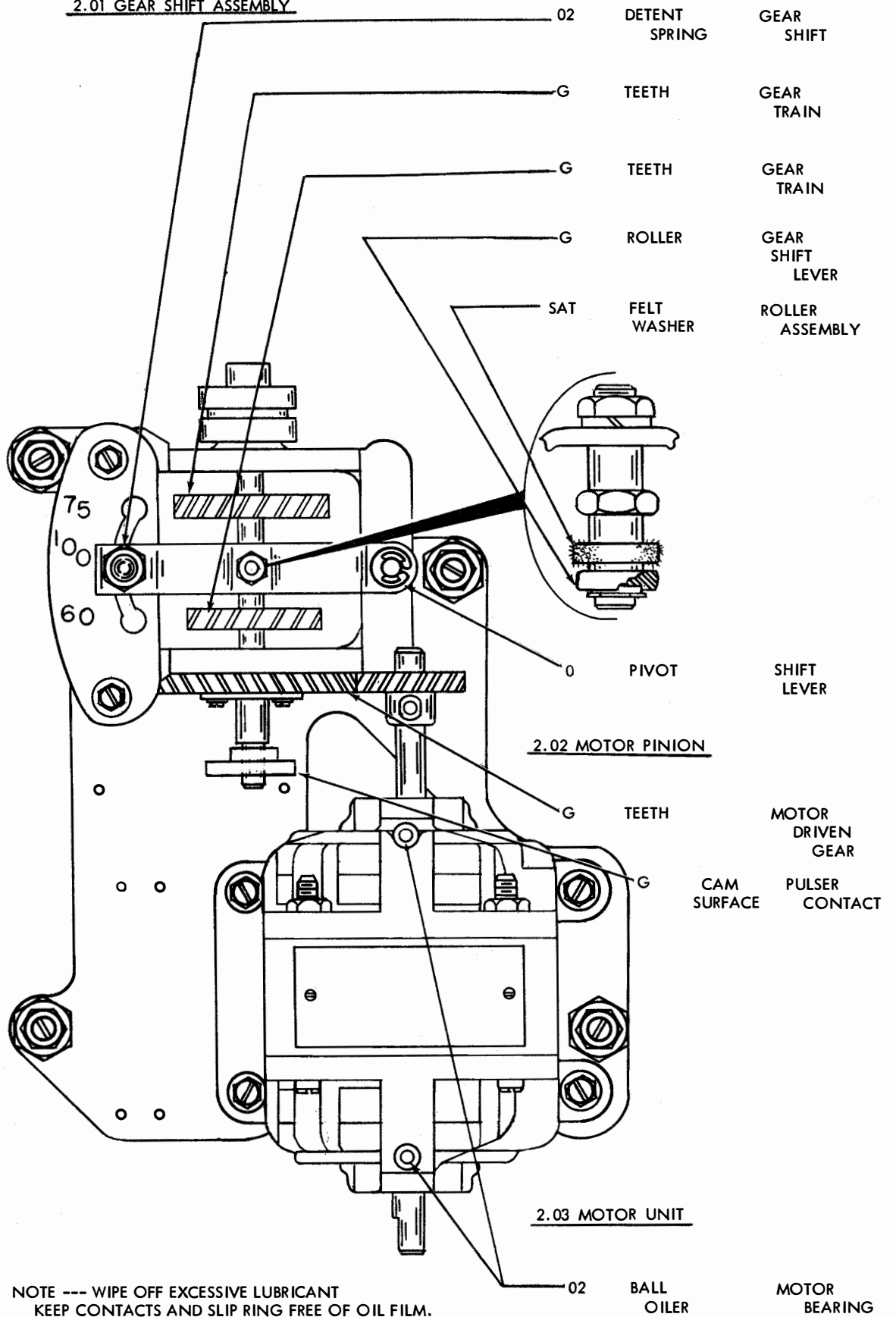

- 02 DETENT SPRING GEAR SHIFT
- G TEETH GEAR TRAIN
- G TEETH GEAR TRAIN
- G ROLLER GEAR SHIFT LEVER
- SAT FELT WASHER ROLLER ASSEMBLY
- 0 PIVOT SHIFT LEVER
- 2.02 MOTOR PINION
- G TEETH MOTOR DRIVEN GEAR
- G CAM SURFACE PULSER CONTACT
- 2.03 MOTOR UNIT
- 02 BALL OILER MOTOR BEARING

NOTE --- WIPE OFF EXCESSIVE LUBRICANT
KEEP CONTACTS AND SLIP RING FREE OF OIL FILM.



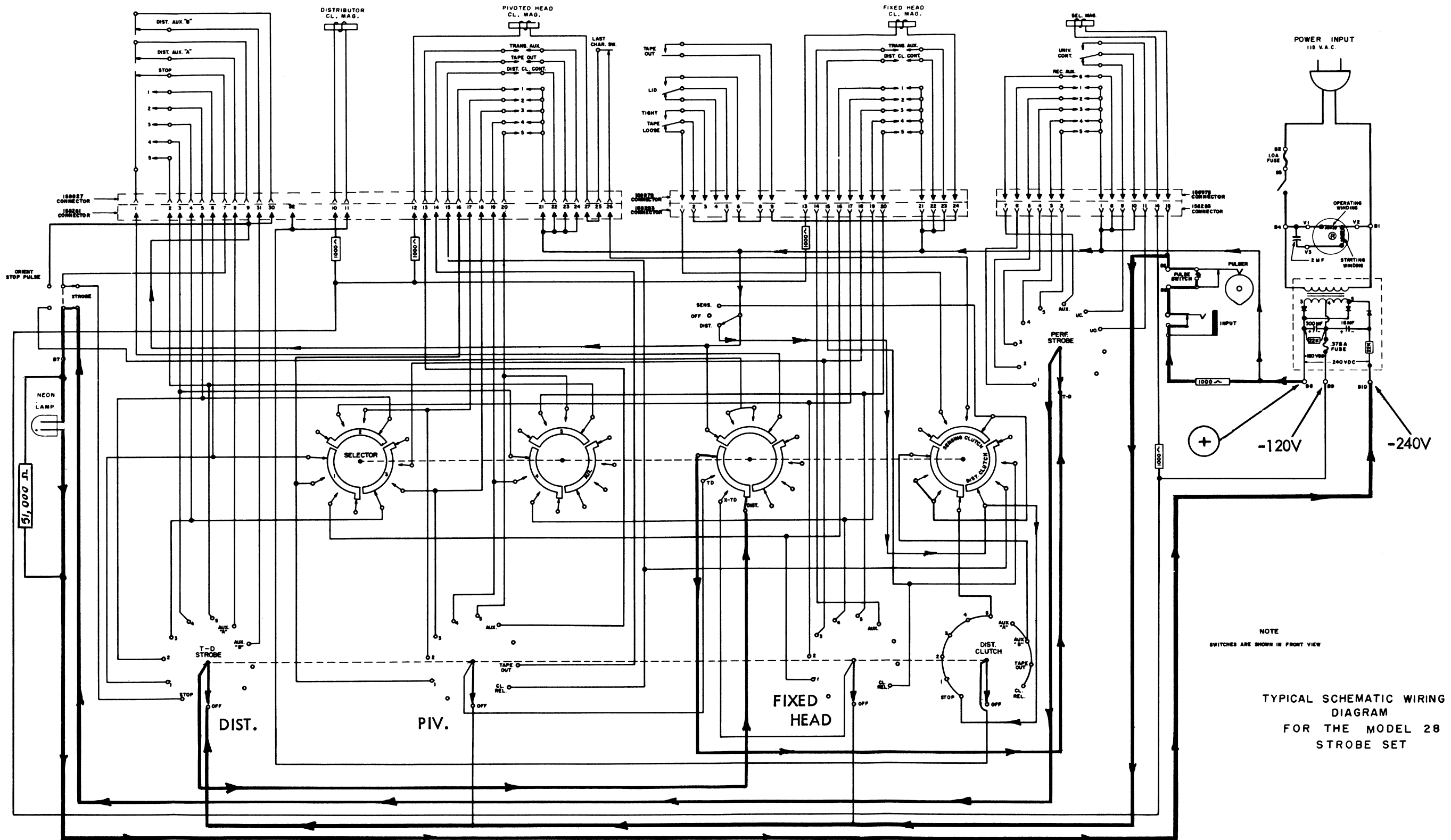
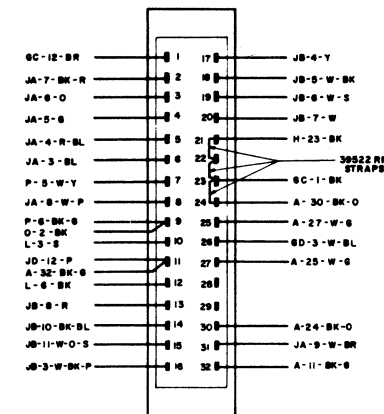

Figure 5-11 Schematic Wiring Diagram
 -14; 5-15

NOTES	
1.	WIRING LEGEND: DISTANT TERMINATING AREA DISTANT TERMINAL DESIGNATION WIRE COLOR CODE
2.	COLOR CODE: BK - BLACK BR - BROWN R - RED O - ORANGE Y - YELLOW G - GREEN BL - BLUE P - PURPLE W - WHITE S - SLATE W-BK - WHITE-BLACK W-BR - WHITE-BROWN W-R - WHITE-RED W-O - WHITE-ORANGE W-Y - WHITE-YELLOW W-G - WHITE-GREEN W-BL - WHITE-BLUE W-P - WHITE-PURPLE W-S - WHITE-SLATE W-BK-P - WHITE-BLACK-PURPLE W-O-S - WHITE-ORANGE-SLATE W-R-BK - WHITE-RED-BLACK
3.	ASSOCIATED CABLES: 16199-CABLE ASSEMBLY 161203-CABLE W/ FUSE HOLDER 161261-BASE CABLE ASSEMBLY 161217-RECTIFIER & CABLE ASSEMBLY 161200-MOTOR & CABLE ASSEMBLY
4.	CABINET POWER MUST BE 115 V. 50-60 ~A.C.
5.	ALL SWITCHES AND CONNECTORS VIEWED FROM THE SOLDERED TERMINAL END.
6.	CABLE TO BE POSITIONED IN CABLE CLAMP IN TAPED AREA
7.	DECK GA AND JA OF THE DECKED SWITCHES ARE LOCATED ADJACENT TO THE CABINET FACE. DECKS GD AND JD ARE THE REAR MOST DECKS.

A
PIVOTED HEAD TRANSMITTER CONNECTOR



H
FIXED HEAD TRANSMITTER CONNECTOR

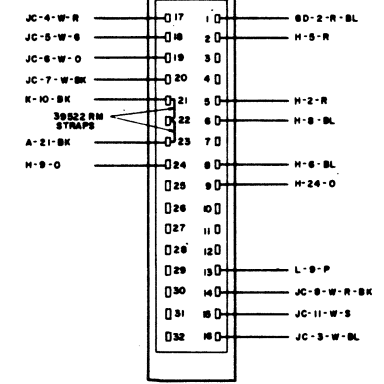

K
REPERFORATOR CONNECTOR

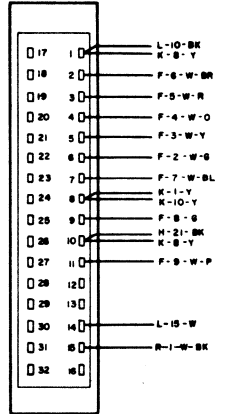

B
CABINET TERMINAL

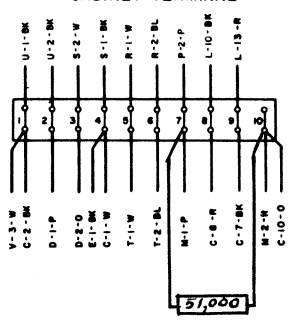

C
RECTIFIER

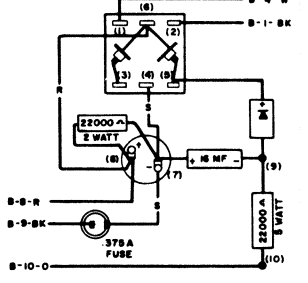

D
FUSE

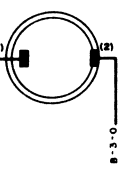

E
CAPACITOR

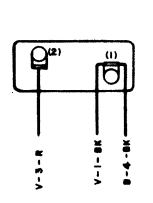

F
PERFORATOR STROB SWITCH

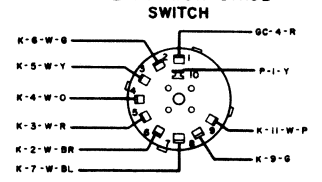

U
A.C. POWER PLUG

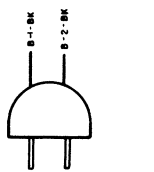

V
BASE PLATE TERMINAL BLOCK & MOTOR

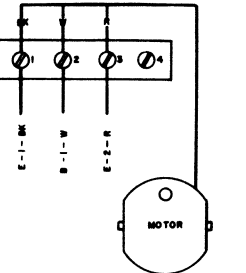

SELECTOR SWITCH

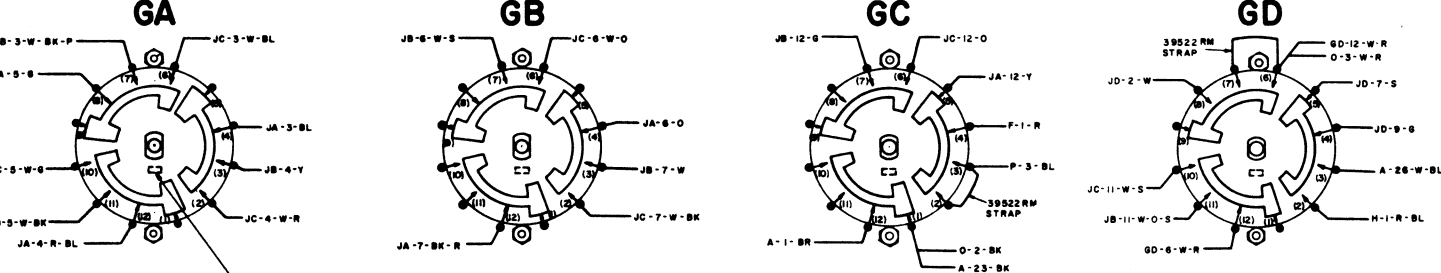

TRANSMITTER-DISTRIBUTOR STROB SWITCH

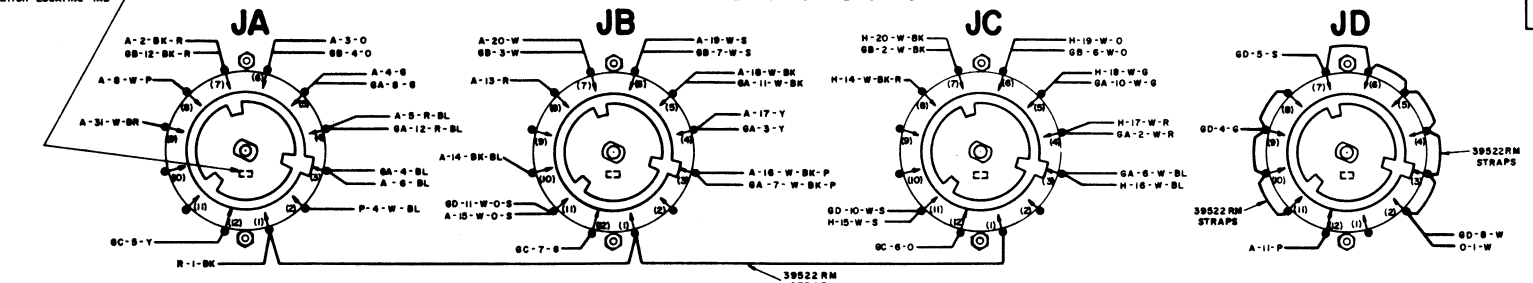

L
RESISTOR ASSEMBLY

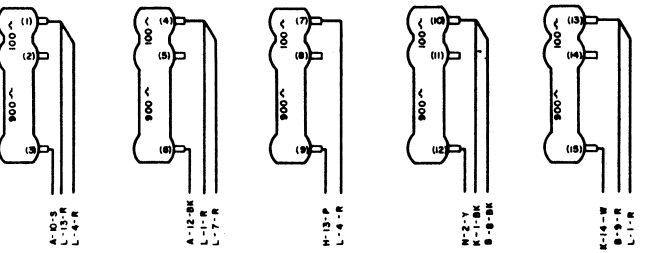

M
HUB ASSEMBLY

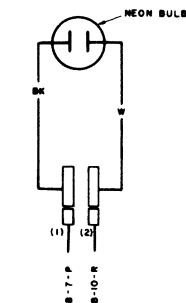

N
SIGNAL INPUT JACK

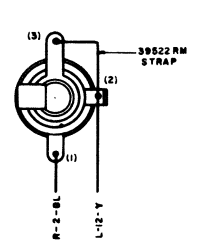

T
PULSER CONTACT

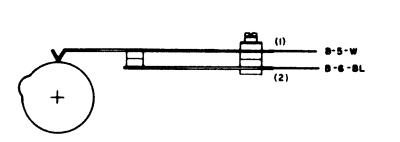

O
SENSE-OFF DISTRIBUTOR SWITCH

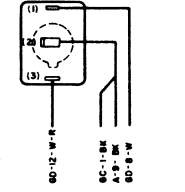

P
STROB-ORIENT SWITCH

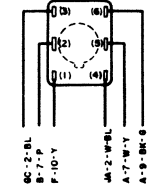

R
PULSER SWITCH

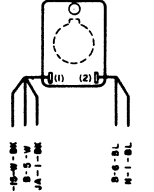

S
POWER SWITCH

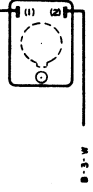

TYPICAL SCHEMATIC WIRING DIAGRAM FOR THE MODEL 28 STROBE SET

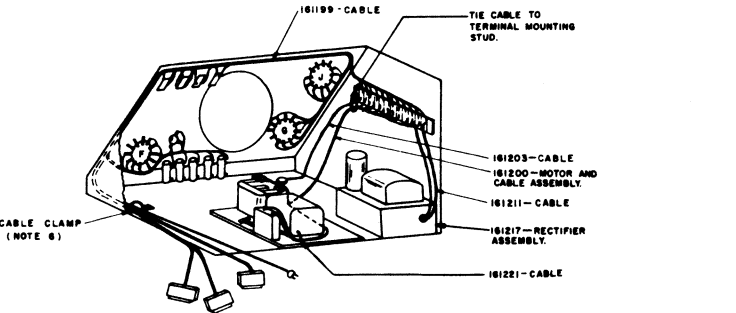

Figure 5-12 Actual Wiring Diagram

SECTION 6
PARTS

PAINT FINISH COLOR CODE CHART (for parts and assemblies requiring a paint finish)							
SMOOTH FINISHES			WRINKLE FINISHES			TEXTURED VINYL	
Suffix	Color	Bell System Code	Suffix	Color	Bell System Code	Suffix	Color
BB	Black Semi-Gloss	34	AA	Black	37		
BK	Gray Green		AB	Gray Green	40	GA	Gray Green
			AC	Light Brown	39		
			AD	Dark Brown	38		
BH	Light Gray						
BU	Light Gray Semi-Gloss						
BV	Federal Gray		AF	Federal Gray			
BX	Sunland Beige						
Suffix to be applied following the part number.							

BELL SYSTEM ONLY

When ordering parts from this bulletin, prefix each number with the letters TP.

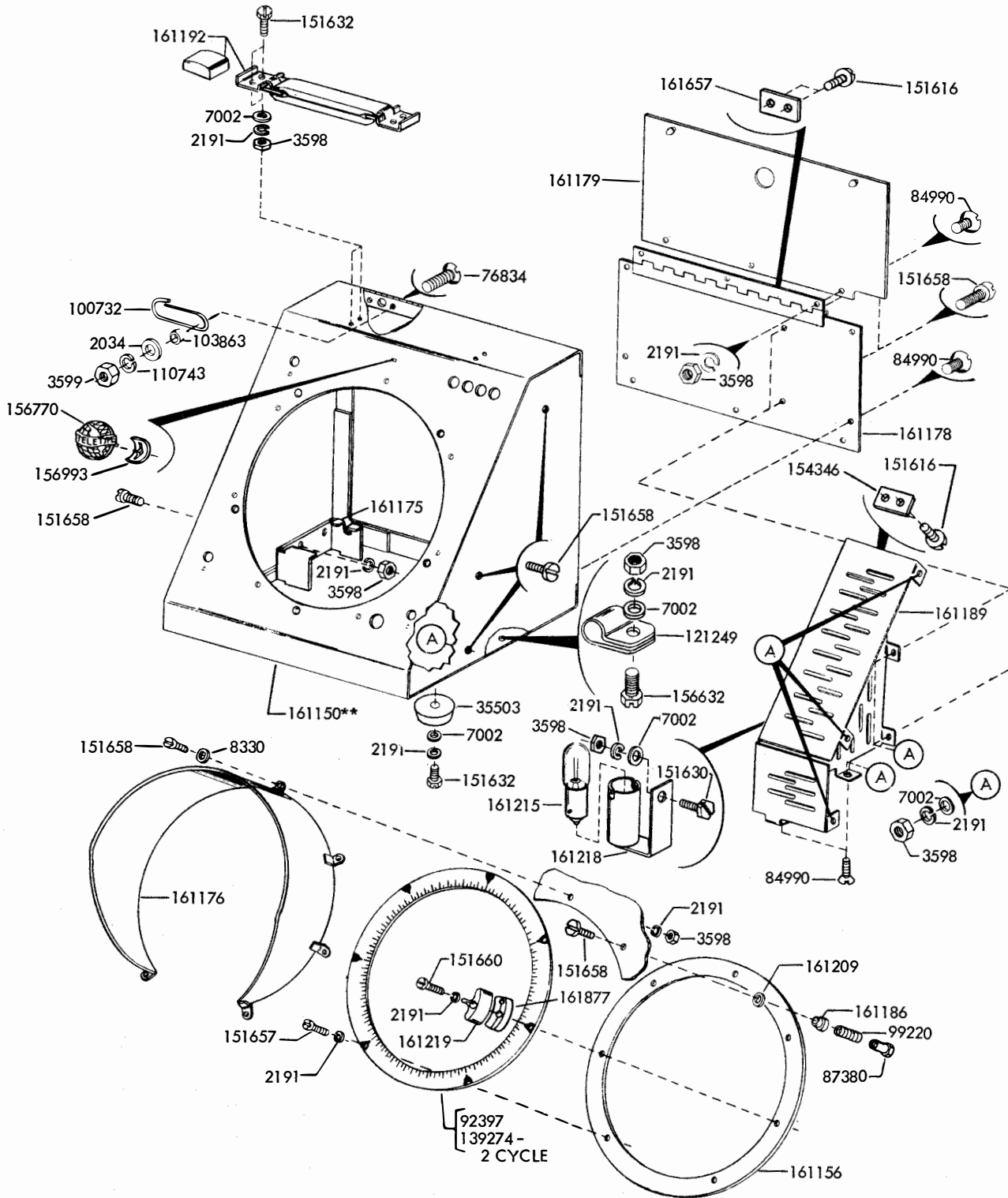

**SEE CHART ON PAGE 6-1
FOR COLOR SUFFIX

FIGURE 6-1. CABINET SHELL AND COMPONENT PARTS

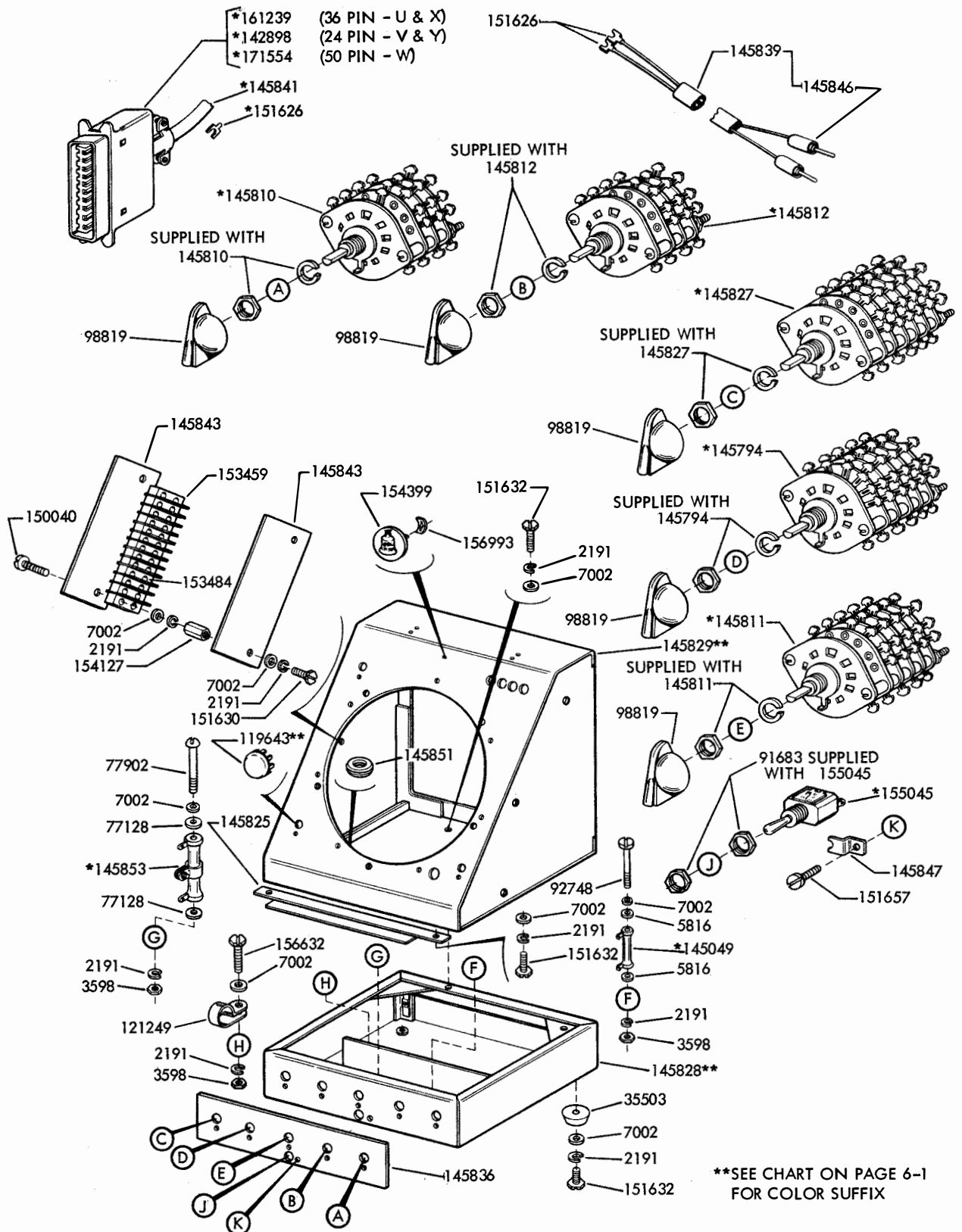

FIGURE 6-2. CABINET SHELL WITH CONTROL BOX AND COMPONENT PARTS

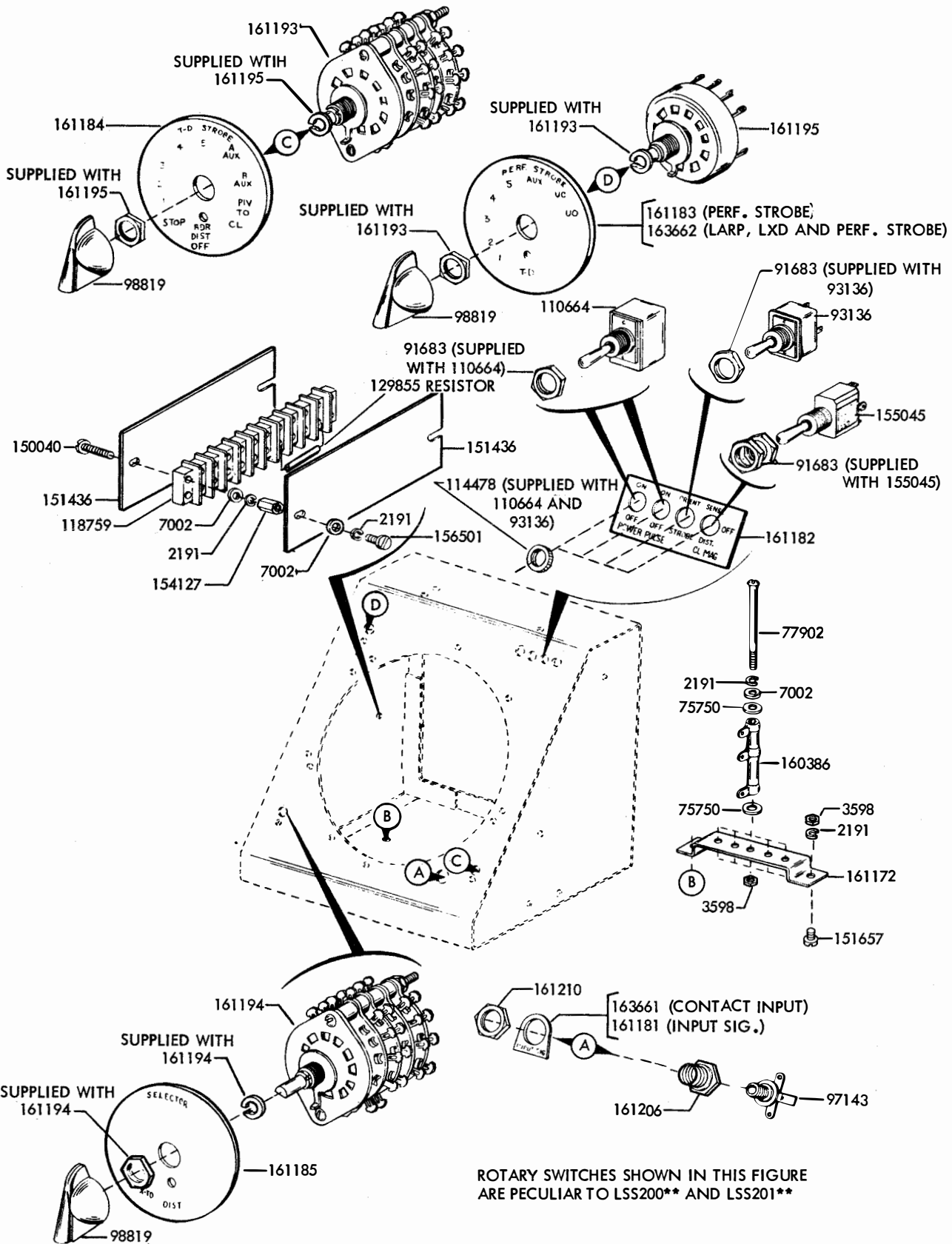

FIGURE 6-3. ELECTRICAL COMPONENTS

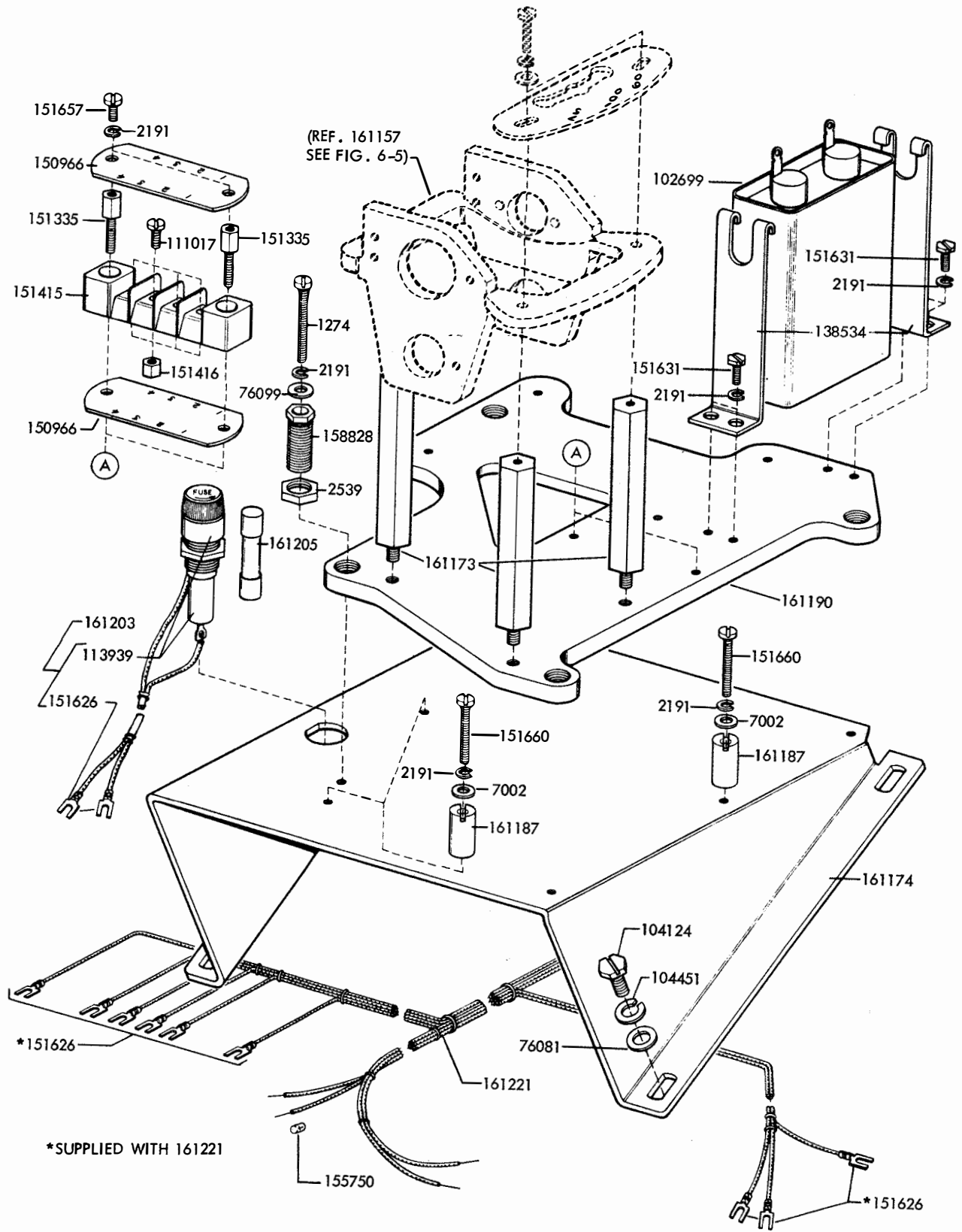

FIGURE 6-4. BASE PLATE, BRACKET AND ELECTRICAL COMPONENTS

CHANGE I

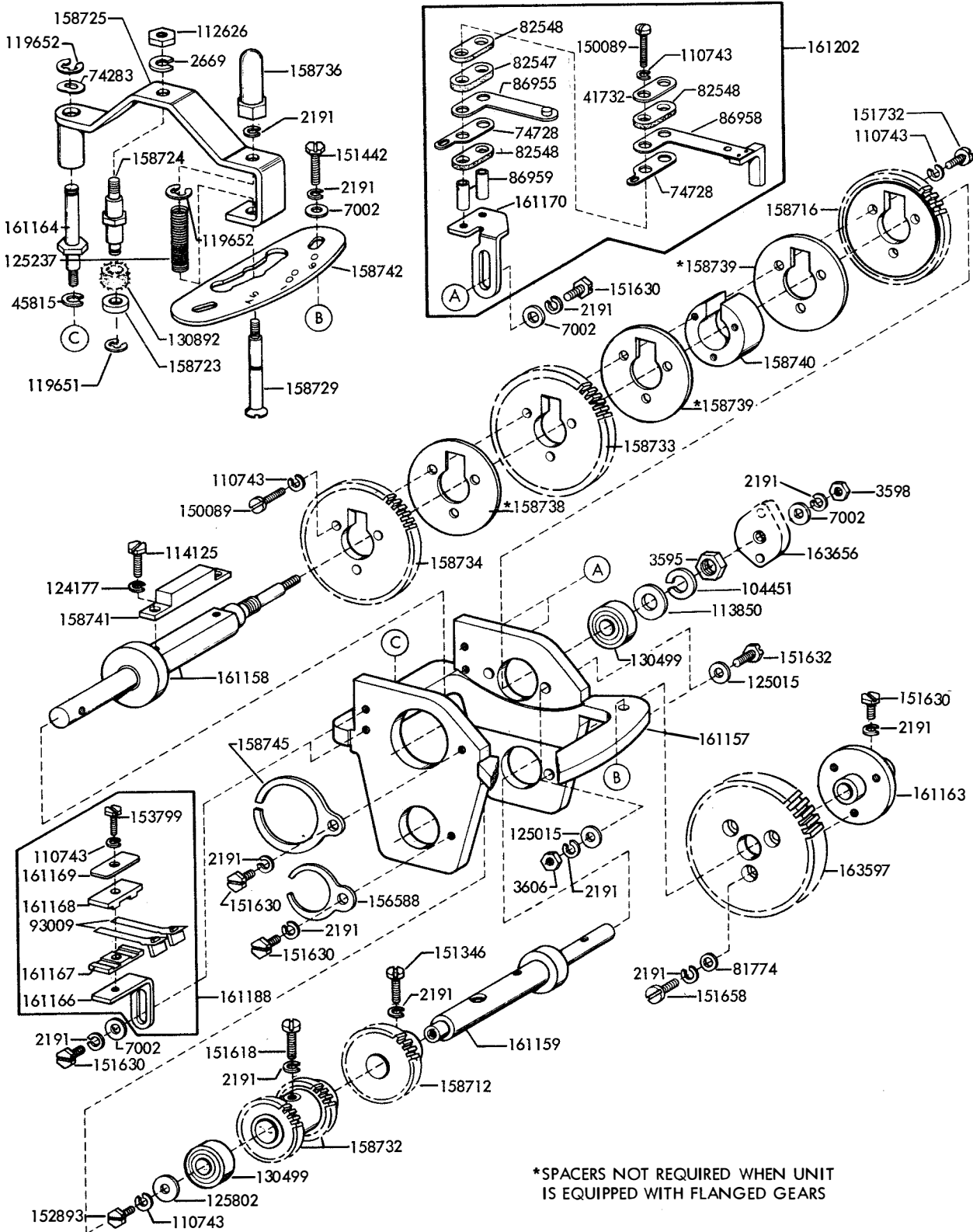
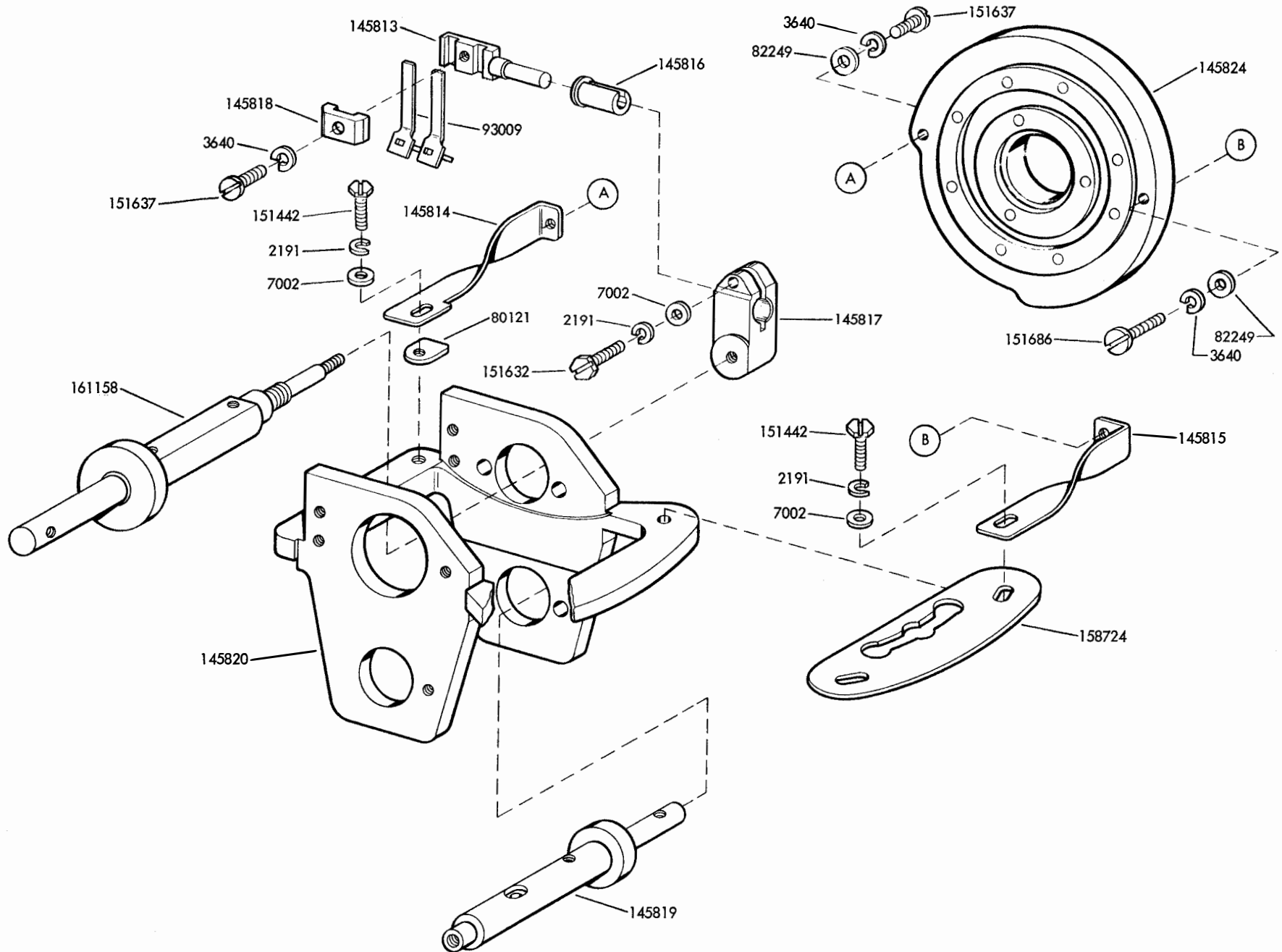

FIGURE 6-5. GEAR SHIFT MECHANISM

CHANGE 1

FIGURE 6-6. GEAR SHIFT BRACKET WITH DISTRIBUTOR DISK MECHANISM



261B

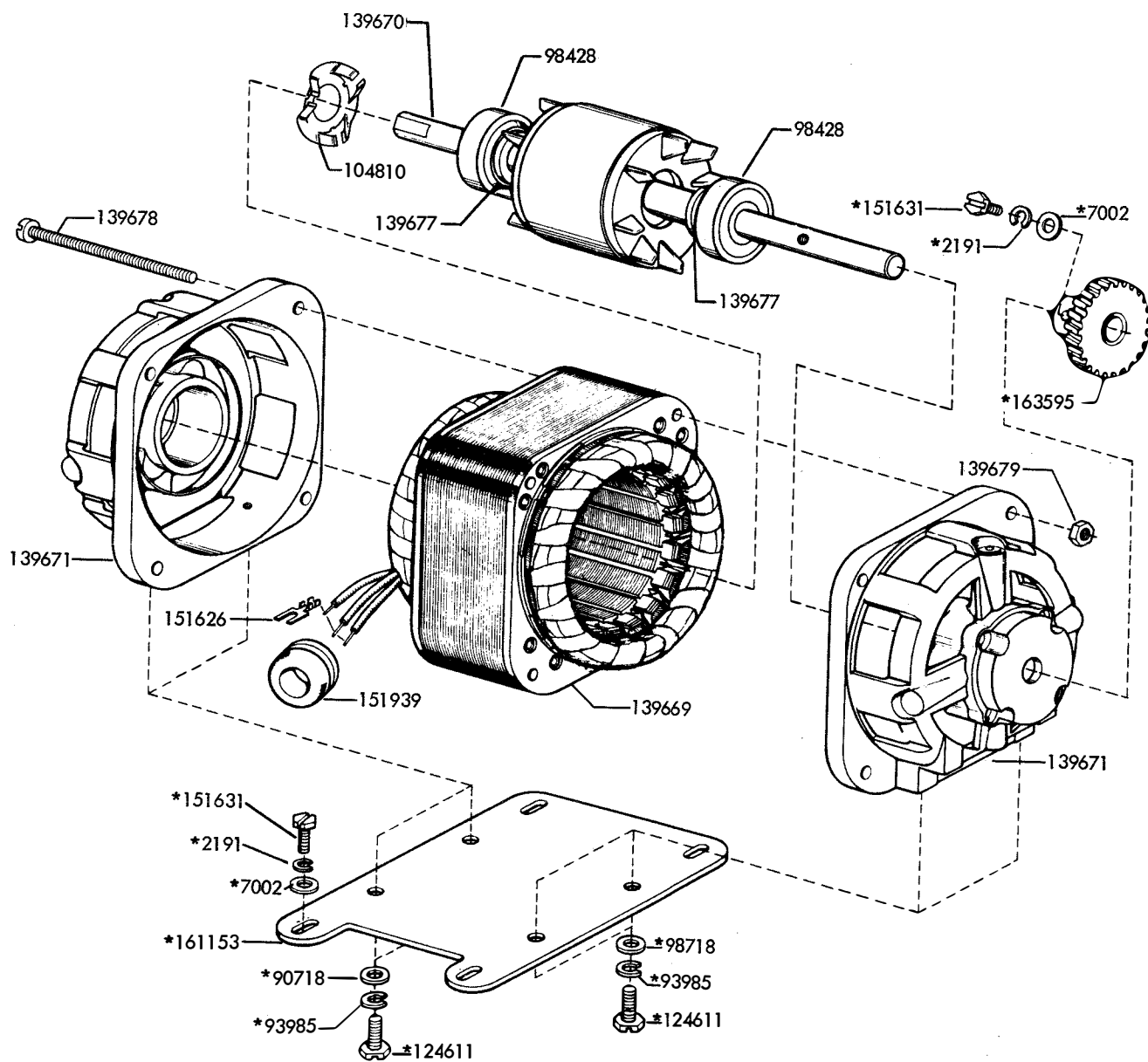

*NOT PART OF 161200

FIGURE 6-7. 161200 MOTOR AND CABLE ASSEMBLY

CHANGE 1

FIGURE 6-8. 161198 HUB ASSEMBLY

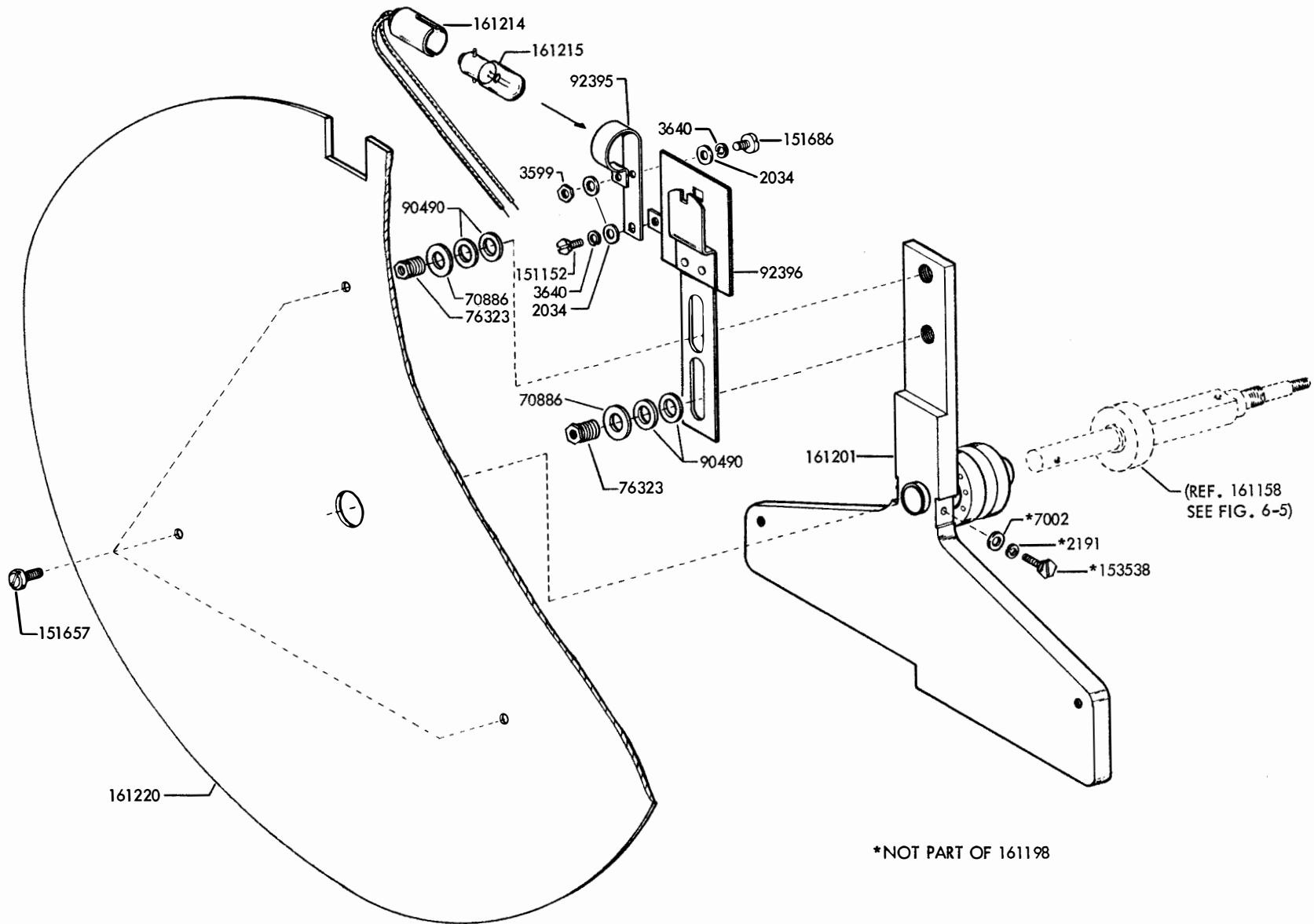

261 B

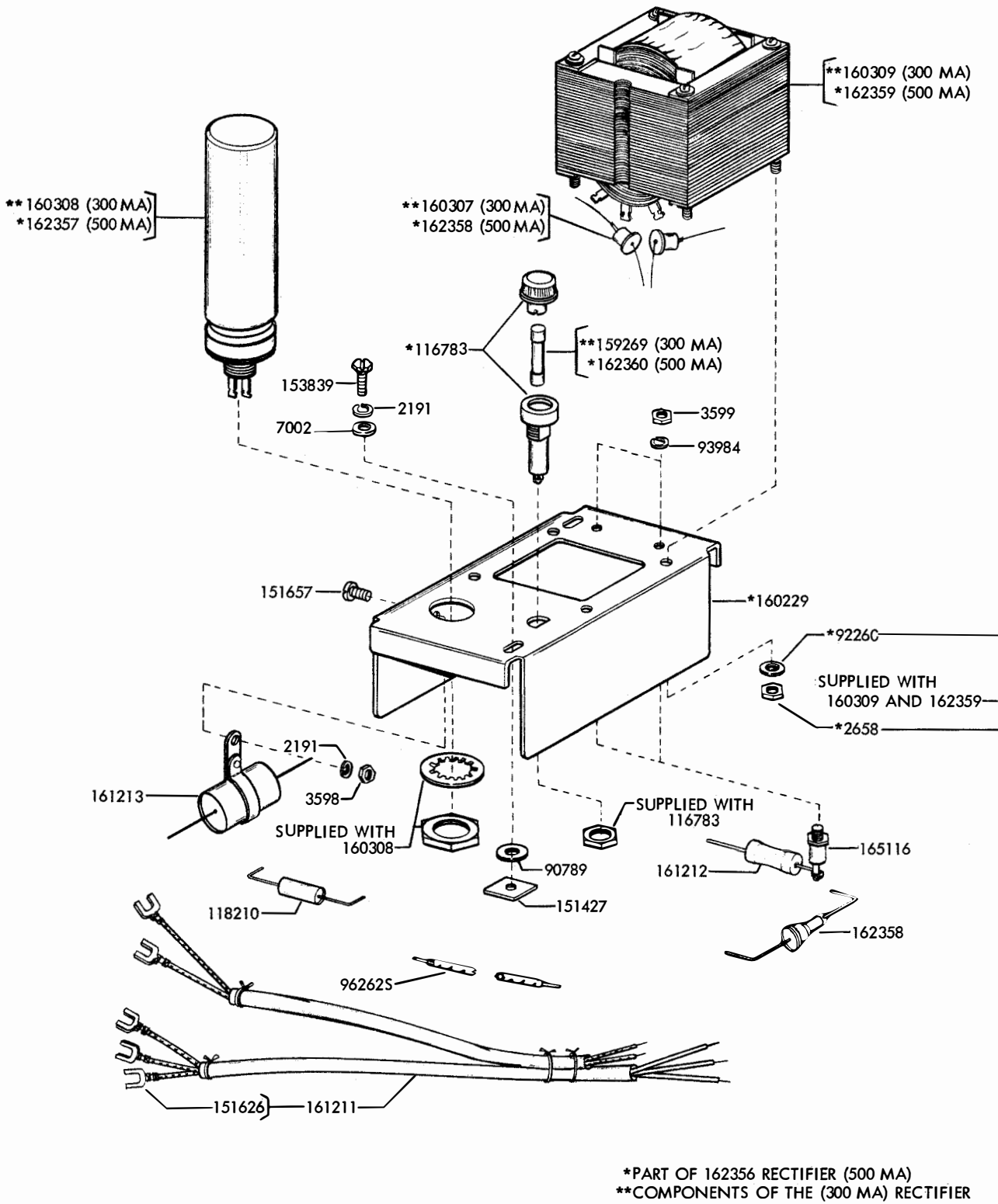

FIGURE 6-9. 161217 500MA RECTIFIER AND CABLE ASSEMBLY

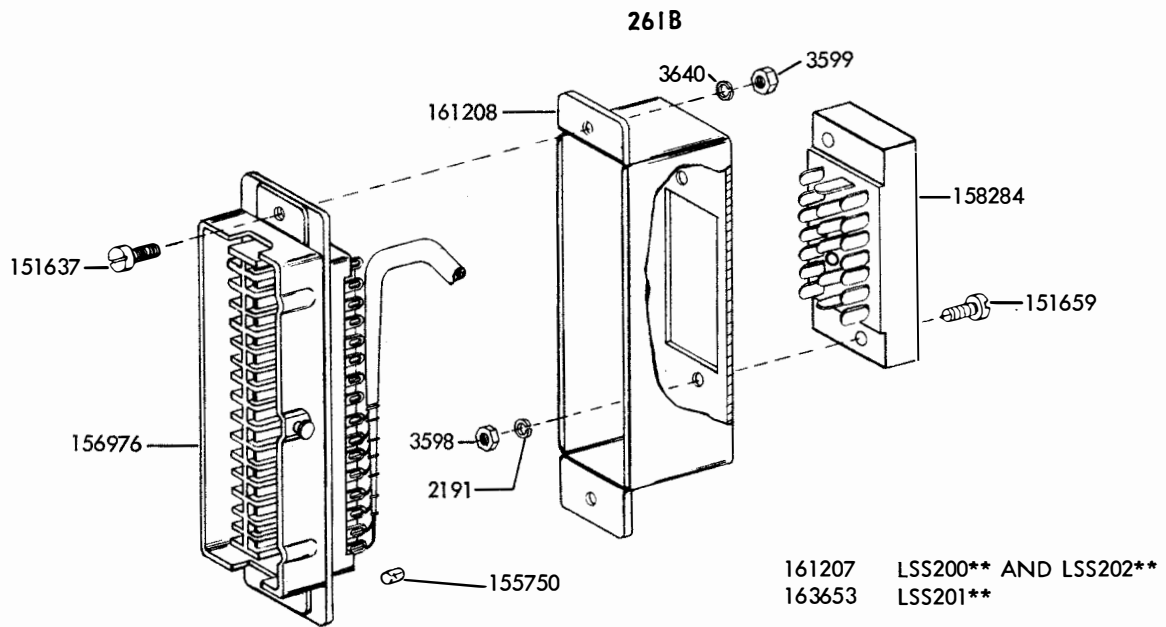

FIGURE 6-10. 161207 AND 163653 CABLE ASSEMBLIES

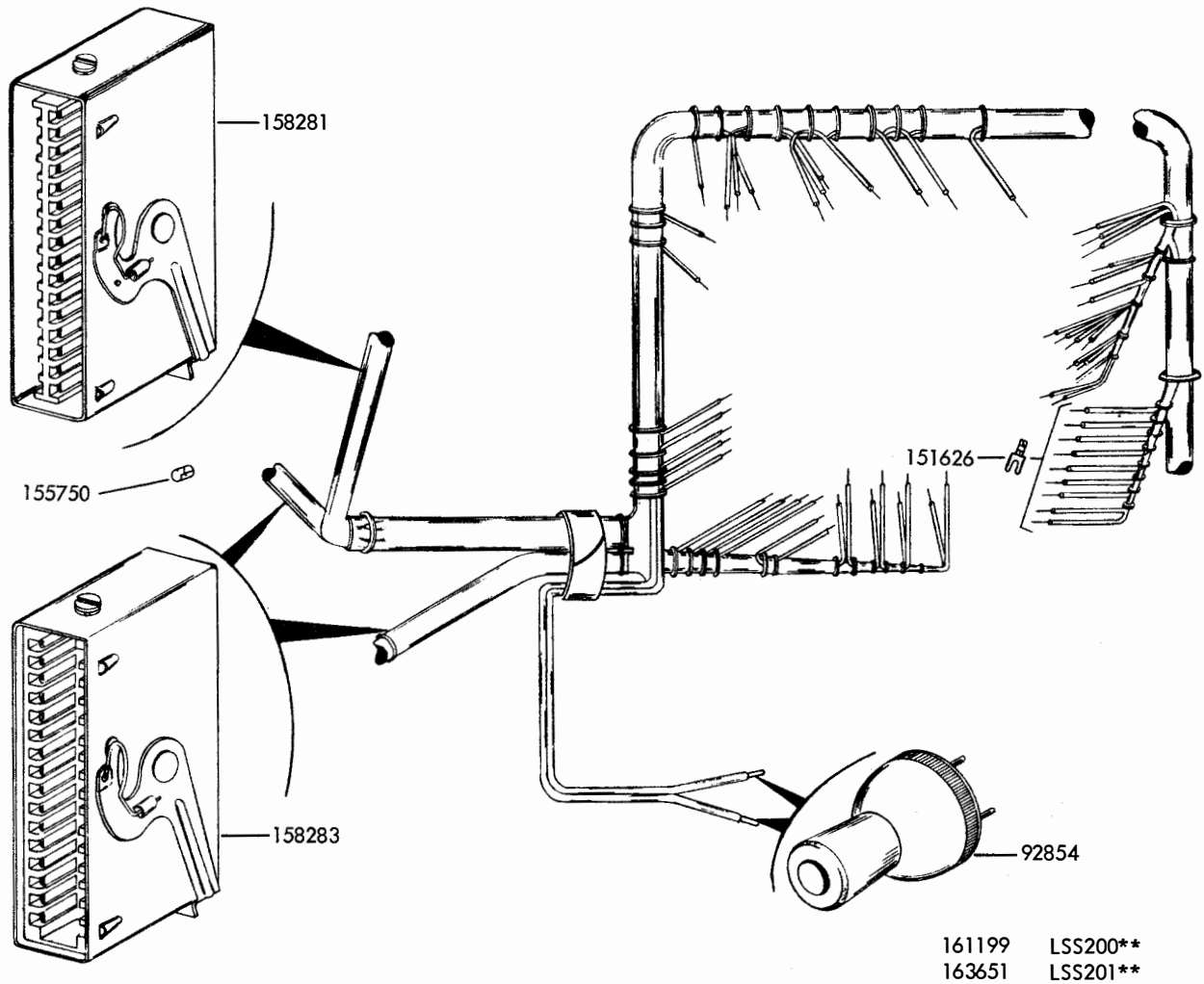
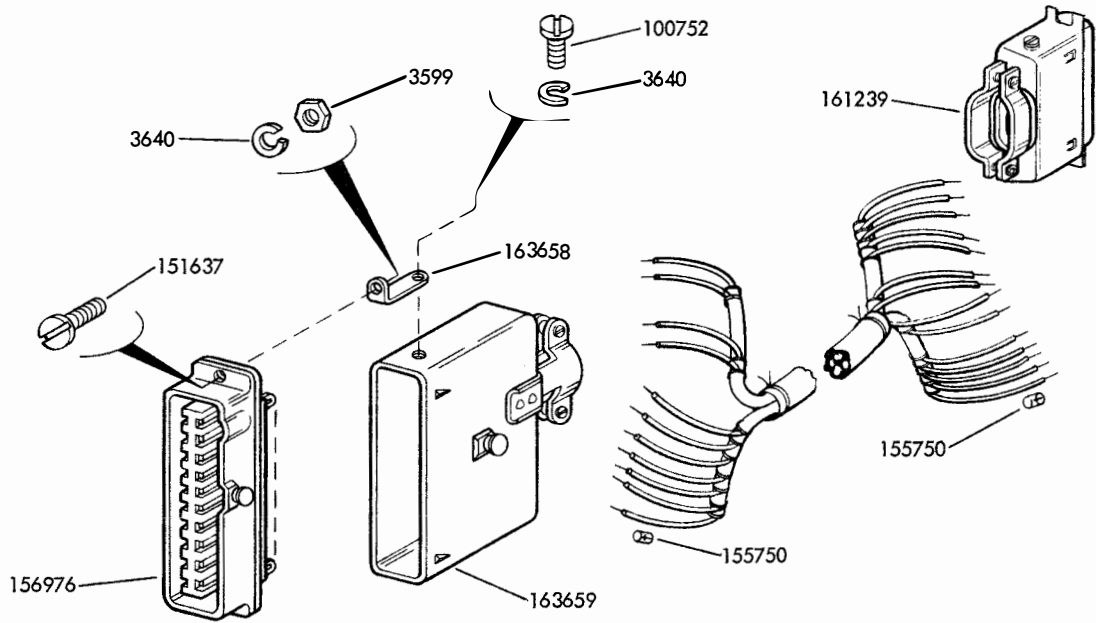
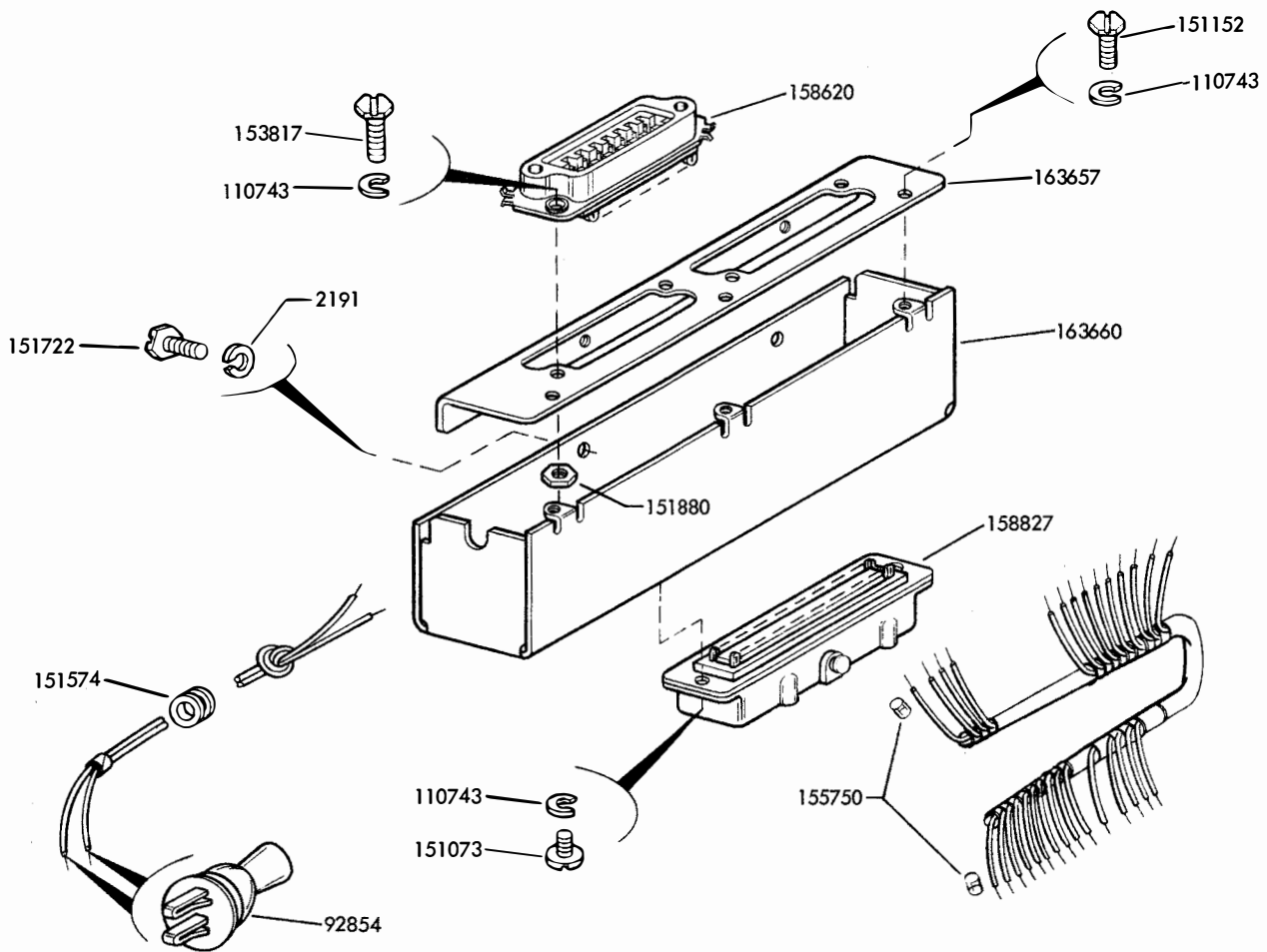

FIGURE 6-11. 161199 AND 163651 CABLE ASSEMBLIES

261B



163655 CABLE ASSEMBLY



163652 CABLE ASSEMBLY

FIGURE 6-12. CABLES FOR THE LSS202** TEST SET

261B

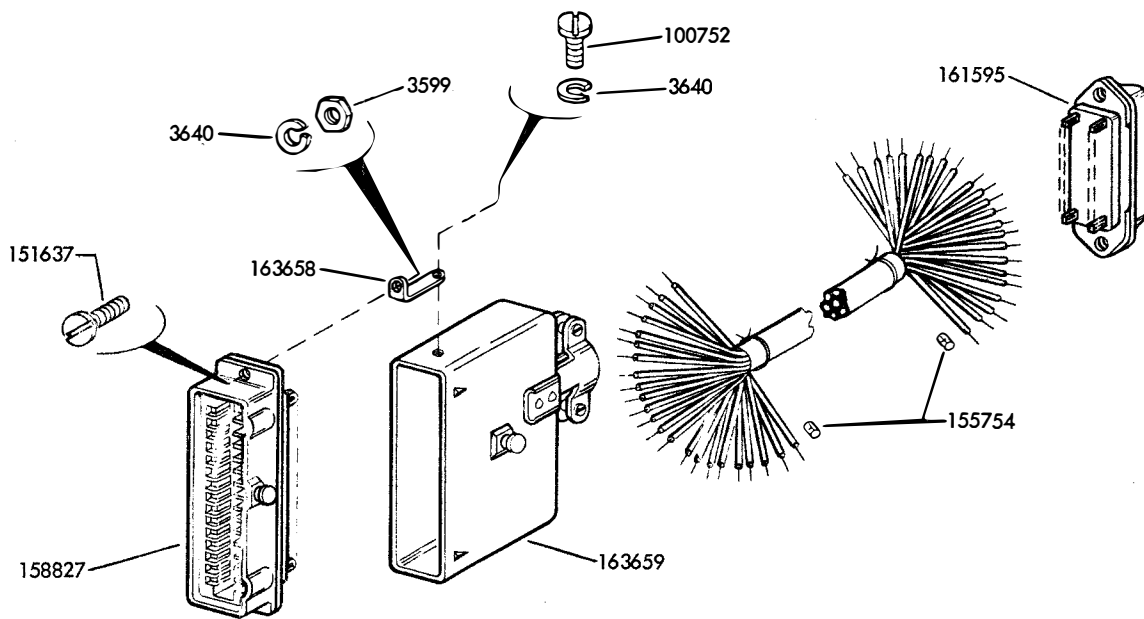

164907 CABLE ASSEMBLY

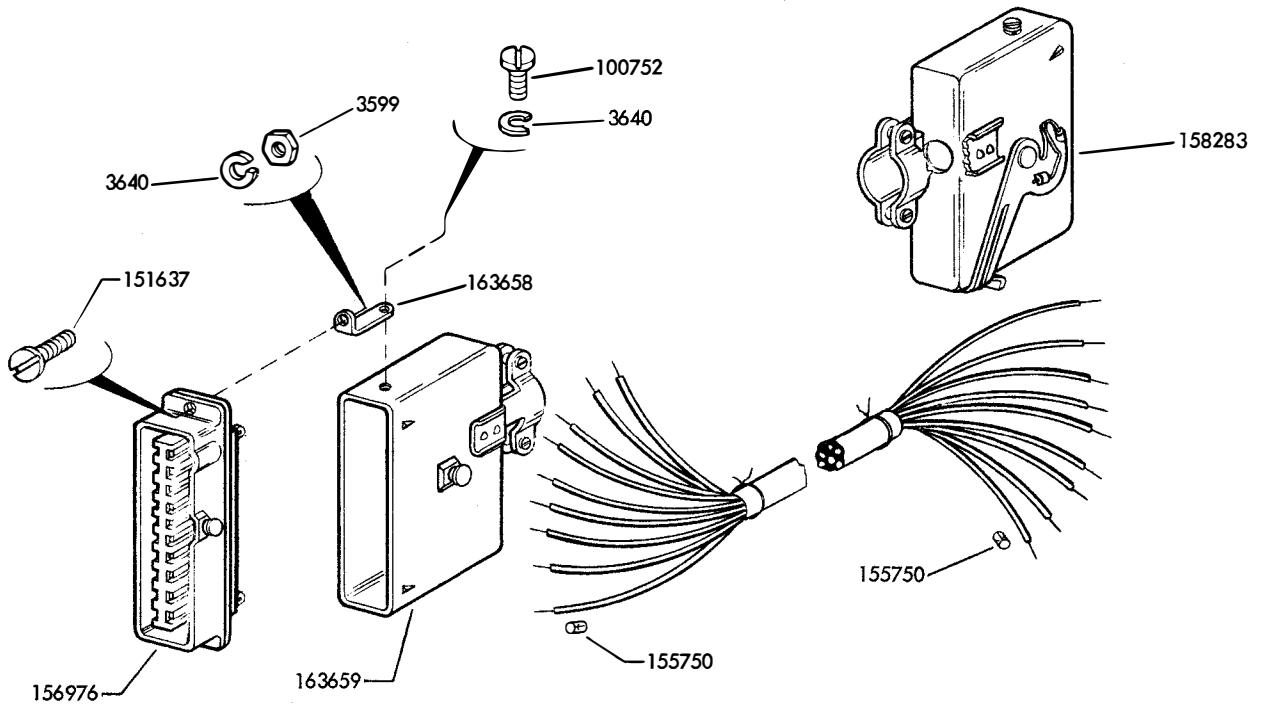

163654 CABLE ASSEMBLY

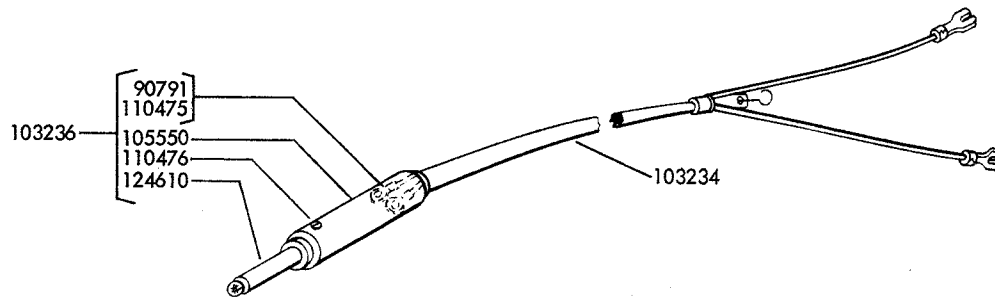

103231 CORD ASSEMBLY

FIGURE 6-13. CABLES FOR THE LSS202** TEST SET

261B

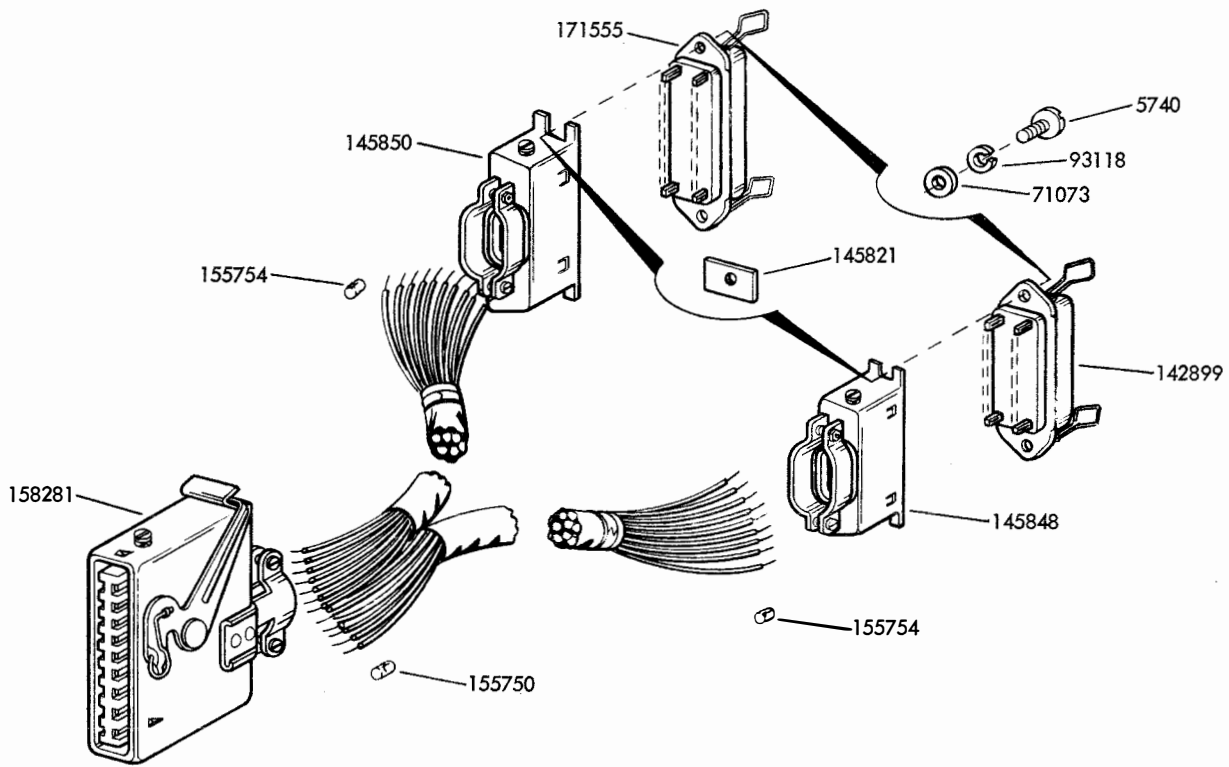

145831 CABLE ASSEMBLY

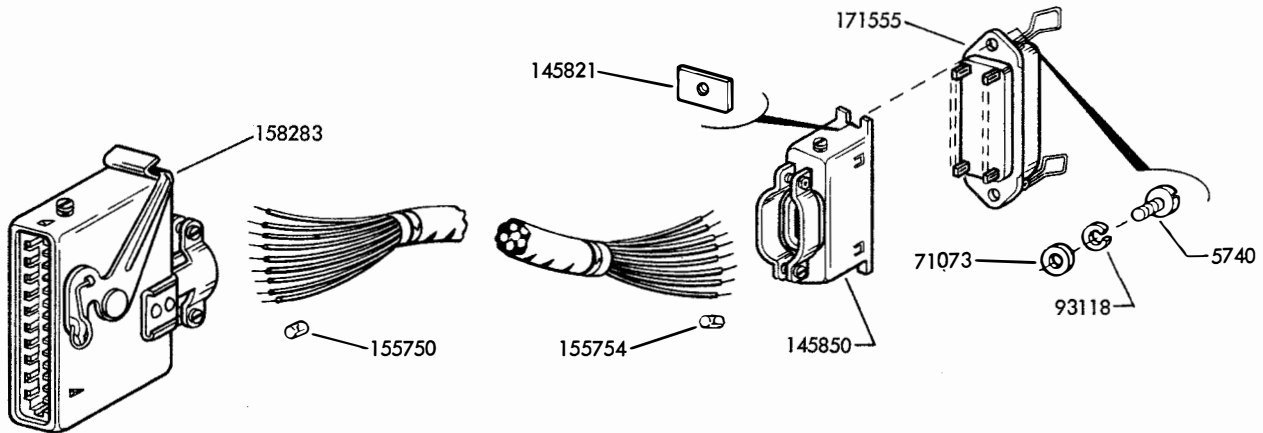

145832 CABLE ASSEMBLY

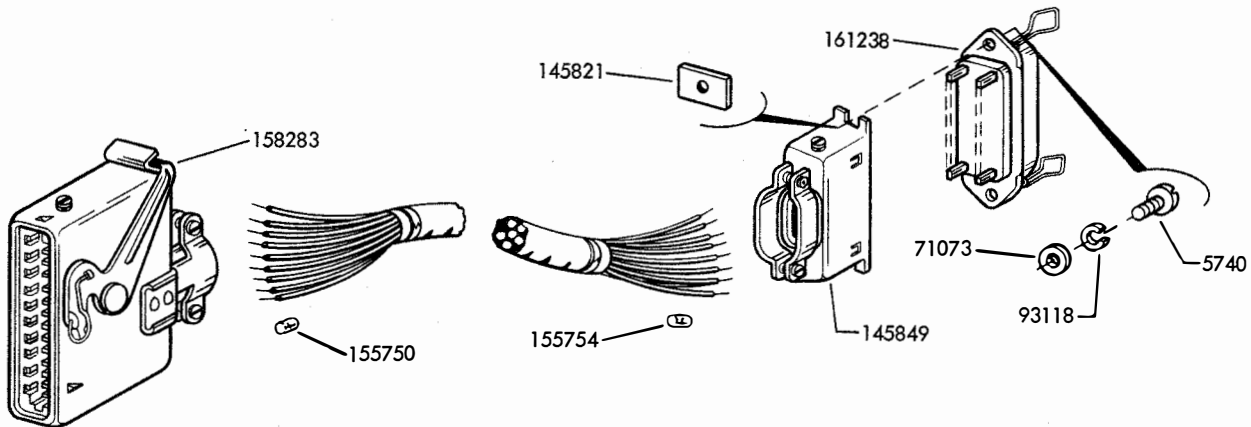

145833 CABLE ASSEMBLY

FIGURE 6-14. ADAPTER CABLES FOR THE LSS202** TEST SET

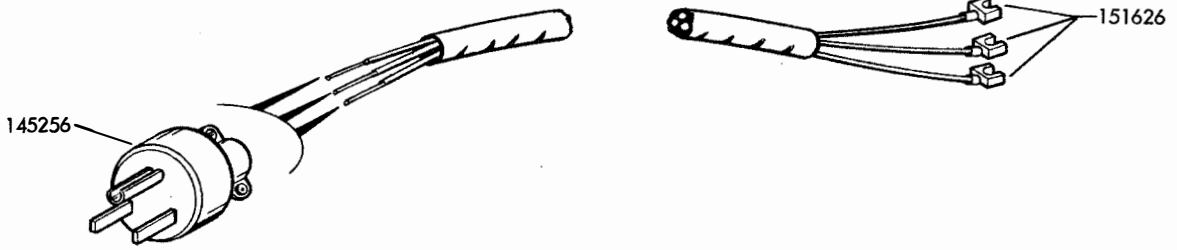

145837 A.C. POWER CORD (APPROX. 8'4" LONG)

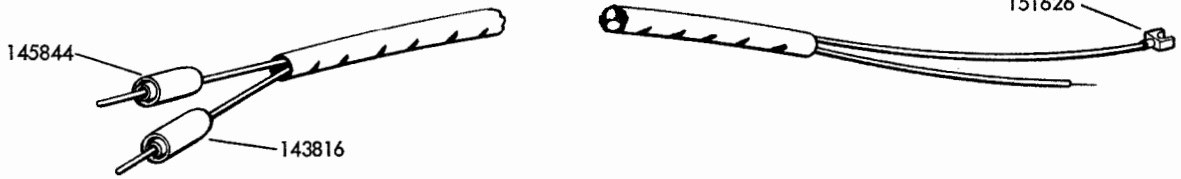

145838 D.C. POWER CORD (APPROX. 8"2" LONG)

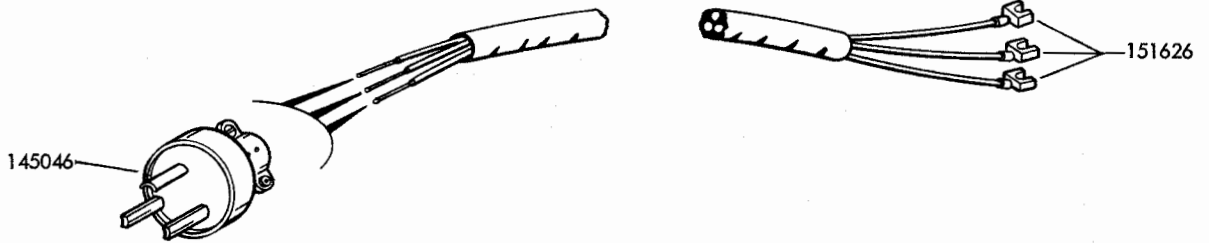

145066 A.C. CABLE ASSEMBLY (APPROX. 1" 6-1/2" LONG)



145845 CABLE ASSEMBLY (APPROX. 1"10" LONG)

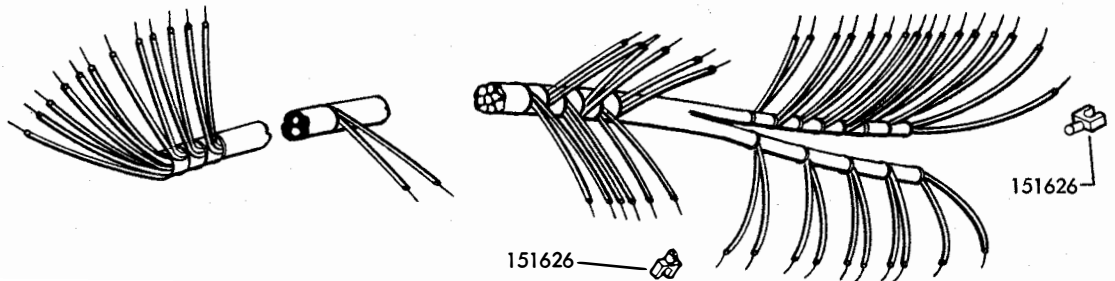

145842 CABLE ASSEMBLY (APPROX. 4"6" LONG)

FIGURE 6-15. CABLES FOR THE LSS202** TEST SET

NUMERICAL INDEX - SECTION 6

Part Number	Description and Page Number	Part Number	Description and Page Number
1051	Screw (4-40 x 1/2 Fil) 6-6	93136	Switch, Toggle 6-4
1248	Screw (6-40 x 7/16 Flat) 6-2	93984	Washer, Lock 6-10
1274	Screw (6-40 x 1-1/8 Fil) 6-5	93985	Washer, Lock 6-8
2034	Washer, Flat 6-2,6-9	96262S	Wire (4" Slate) 6-10
2191	Washer, Lock 6-2,6-3,6-4,6-5,6-6,6-7, 6-8,6-9,6-10,6-11,6-12	97143	Jack 6-4
2539	Nut (3/8-32 Hex) 6-5	98428	Bearing, Ball 6-8
2658	Nut (6-32 Hex) 6-10	98718	Washer, Flat 6-8
2669	Washer, Lock 6-6	98819	Knob 6-3,6-4
3595	Nut (1/4-32 Hex) 6-6	99220	Spring 6-2
3598	Nut (6-40 Hex) 6-3,6-6,6-10,6-11	100732	Spring 6-2
3599	Nut (4-40 Hex) 6-2,6-9,6-10,6-11,6-12, 6-13	100752	Screw (4-40 x 3/16 Fil) 6-12,6-13
3606	Nut (6-40 Hex) 6-6	102699	Capacitor (2MF) 6-5
3640	Washer, Lock 6-7,6-9,6-11,6-12,6-13	103231	Cord Assembly 6-13
5740	Screw (2-56 x 1/4 Fil) 6-14	103234	Cord 6-13
5816	Washer, Fiber 6-3	103236	Plug 6-13
7002	Washer, Flat 6-2,6-3,6-4, 6-5,6-6,6-7,6-8,6-9, 6-10	103863	Spacer 6-2
8330	Washer, Flat 6-2	104124	Screw (1/4-32 x 11/32 Hex) 6-5
35503	Foot, Rubber 6-2,6-3	104451	Washer, Lock 6-5,6-6
41732	Plate, Clamp 6-6	104564	Spacer 6-6
45815	Washer, Lock 6-6	104810	Spring 6-8
70886	Washer, Flat 6-9	105550	Shell, Plug (Black) 6-13
71073	Washer, Flat 6-14	110475	Screw (2-64 x 5/64 Rd) 6-13
74283	Washer, Spring 6-6	110476	Screw (4-48 x 5/64 Fil) 6-13
74728	Terminal, Contact 6-6	110664	Switch, Toggle 6-4
75750	Washer, Fiber 6-4	110743	Washer, Lock 6-2,6-6,6-12
76081	Washer, Flat 6-5	111017	Screw (6-40 x 5/16 Fil) 6-5
76099	Washer, Flat 6-4	112206	Washer, Flat 6-5
76323	Bushing 6-9	112485	Screw (6-40 x 1/4 Fil) 6-10
76834	Screw (4-40 x 13/32 Flat) 6-2	112626	Nut (10-32 Hex) 6-6
77128	Washer, Flat 6-3	113850	Washer, Flat 6-6
77902	Screw (6-40 x 2-3/8 Rd) 6-3,6-4	113939	Holder, Fuse 6-5
80121	Shim (.095") 6-7	114125	Screw (6-40 x 3/8 Hex) 6-6
81774	Washer, Flat 6-6	114478	Nut (15/32-32 Hex) 6-4
82249	Washer, Flat 6-7	116783	Holder, Fuse 6-10
82547	Insulator 6-6	118210	Resistor (22000 Ohms) 6-10
82548	Insulator 6-6	118759	Block, Terminal 6-4
84990	Screw (6-40 x 9/32 Flat) 6-2	119643**	Button, Plug 6-3
85559	Washer, Flat 6-9	119651	Ring, Retaining 6-6
86955	Spring, Contact 6-6	119652	Ring, Retaining 6-6
86958	Spring, Contact 6-6	121249	Clamp, Cable 6-2,6-3
86959	Bushing, Insulating 6-6	124177	Washer, Lock 6-6, 6-8
87380	Bushing 6-2	124610	Body, Plug 6-1
90490	Shim (.005") 6-9	124611	Screw (8-32 x 3/8 Hex) 6-8
90789	Washer, Flat 6-10	125015	Washer, Flat 6-6
90791	Washer, Lock 6-13	125237	Spring 6-6
91683	Nut (15/32-32 Hex) 6-3,6-4	125802	Washer, Flat 6-6
91684	Nut (15/32-32 Ring) 6-4	129855	Resistor (51000 Ohms) 6-4
92260	Washer, Lock 6-10	130499	Bearing, Ball 6-6
92395	Clamp, Lamp 6-9	130892	Oiler, Felt 6-6
92396	Arm, Indicator Lamp 6-9	138534	Bracket, Capacitor Mounting 6-5
92397	Scale 6-2	139274	Scale (2 cycle) 6-2
92748	Screw (6-40 x 1-7/16 Fil) 6-3	139669	Stator 6-8
92854	Connector, Plug (2 PT) 6-11,6-12	139670	Rotor W/Bearings and Washers 6-8
93009	Spring, Brush 6-6,6-7	139671	Shield, End 6-8
93118	Washer, Lock 6-14	139677	Washer, Pull 6-8
		139678	Screw (8-32 x 2 Fil) 6-8
		139679	Nut (8-32 Hex) 6-8
		142898	Connector, Plug (24 PT) 6-3
		142899	Connector, Receptacle (24PT) 6-14

NUMERICAL INDEX - SECTION 6 (Continued)

Part Number	Description and Page Number	Part Number	Description and Page Number
143816	Plug, Tip 6-15	151631	Screw (6-40 x 5/16 Hex) 6-5,6-8
145046	Connector, Plug (3 PT) 6-15	151632	Screw (6-40 x 3/8 Hex) 6-3,6-6,6-7
145049	Resistor (200 Ohms) 6-3	151637	Screw (4-40 x 3/16 Fil) 6-7,6-11,6-12,6-13
145066	Cable Assembly 6-15	151642	Screw (6-40 x 3/4 Fil) 6-2
145256	Connector, Plug (3 PT) 6-15	151657	Screw (6-40 x 1/4 Fil) 6-2,6-3,6-4,6-5,6-9
145794	Switch, Rotary 6-3	151658	Screw (6-40 x 5/16 Fil) 6-2,6-6
145810	Switch, Rotary 6-3	151659	Screw (6-40 x 1/2 Fil) 6-11
145811	Switch, Rotary 6-3	151660	Screw (6-40 x 7/8 Fil) 6-2,6-5
145812	Switch, Rotary 6-3	151686	Screw (6-40 x 5/16 Fil) 6-7,6-9
145813	Arm, Brush 6-7	151692	Screw (6-40 x 3/16 Fil) 6-4
145814	Bracket, Mounting 6-7	151722	Screw (6-40 x 3/16 Hex) 6-12
145815	Bracket, Mounting 6-7	151732	Screw (6-40 x 11/32 Fil) 6-6
145816	Bushing, Insulating 6-7	151880	Nut (4-40 Hex) 6-12
145817	Arm, Brush Holder 6-7	151939	Grommet, Rubber 6-8
145818	Clamp, Brush Holder 6-7	152893	Screw (4-40 x 1/4 Fil) 6-6
145819	Shaft W/Bearing, Lower 6-7	153459	Block, Terminal 6-3
145820	Bracket 6-7	153484	Screw (6-32 x 1/4 Rd) 6-3
145821	Nut, Plate 6-14	153538	Screw (6-40 x 7/16 Hex) 6-9
145824	Disk 6-7	153799	Screw (4-40 x 21/64 Hex) 6-6
145825	Catch W/Strip, Mounting 6-3	153817	Screw (4-40 x 3/8 Hex) 6-12
145827	Switch, Rotary 6-3	153839	Screw (6-40 x 5/8 Hex) 6-10
145828**	Box, Control 6-3	154127	Nut (6-40 Hex) 6-3,6-4
145829**	Cabinet, Test 6-3	154346	Plate, Instruction 6-2
145831	Cable Assembly 6-14	154399	Plate, Index 6-3
145832	Cable Assembly 6-14	155045	Switch, Toggle 6-3,6-4
145833	Cable Assembly 6-14	155750	Sleeve, Insulating 6-5,6-11,6-12,6-13,6-14
145836	Plate, Designation 6-3	155754	Sleeve, Insulating 6-13,6-14
145837	Cord, Power 6-15	156501	Screw (6-40 x 7/32 Fil) 6-4
145838	Cord, Power 6-15	156588	Ring, Retaining 6-6
145839	Cord, Test 6-3	156632	Screw (6-40 x 13/32 Hex) 6-2,6-3
145841	Cable Assembly 6-3	156770	Plate, Identification 6-2
145842	Cable Assembly 6-15	156976	Connector, Plug (32 PT) 6-11,6-12,6-13
145843	Insulator 6-3	156993	Nut, Speed 6-2,6-3
145844	Plug, Tip 6-15	158281	Connector, Plug (32 PT) 6-11,6-14
145845	Cable Assembly 6-15	158283	Connector, Receptacle (32 PT) 6-11,6-13,6-14
145846	Plug, Tip 6-3	158284	Connector, Receptacle (20 PT) 6-11
145847	Bracket, Stop 6-3	158620	Connector, Receptacle (34 PT) 6-12
145848	Cover, Connector 6-14	158712	Gear (26T) 6-6
145849	Cover, Connector 6-14	158716	Gear (39T) 6-6
145850	Cover, Connector 6-14	158723	Roller 6-6
145851	Grommet, Rubber 6-3	158724	Stud 6-6,6-7
145853	Resistor (100 Ohms) 6-3	158725	Arm W/Bushing 6-6
150040	Screw (6-40 x 5/8 Fil) 6-3,6-4	158729	Stud 6-6
150089	Screw (4-40 x 1/2 Fil) 6-6	158732	Gear (18T and 24T) 6-6
150966	Insulator, Terminal Block 6-5	158733	Gear (44T) 6-6
151073	Screw (4-40 x 5/32 Fil) 6-12	158734	Gear (47T) 6-6
151152	Screw (4-40 x 3/16 Hex) 6-9,6-12	158736	Nut, Cap 6-6
151335	Stud, Terminal Block 6-5	158738	Spacer 6-6
151346	Screw (6-40 x 3/8 Fil) 6-6	158739	Disk 6-6
151415	Block, Terminal 6-5	158740	Block 6-6
151416	Nut (6-40 Hex) 6-5	158741	Bar 6-6
151427	Plate, Clamp 6-10	158742	Plate, Locating 6-6
151436	Cover 6-4	158745	Plate, Clamp 6-6
151442	Screw (6-40 x 1/2 Hex) 6-6,6-7	158827	Connector, Plug (32 PT) 6-12,6-13
151574	Grommet, Rubber 6-12	158828	Screw (3/8-32 x 3/4 Hex) 6-5
151616	Screw, Self Tapping 6-2	159269	Fuse (3/8 Amp) 6-10
151618	Screw (6-40 x 7/16 Fil) 6-6	160229	Plate, Mounting 6-10
151626	Terminal 6-3,6-5,6-8,6-10,6-11,6-15	160307	Diode, Silicon 6-10
151630	Screw (6-40 x 1/4 Hex) 6-3,6-6	160308	Capacitor (300 MF) 6-10

NUMERICAL INDEX - SECTION 6 (Continued)

Part Number	Description and Page Number	Part Number	Description and Page Number
160309	Transformer 6-10	161206	Bushing, Insulating 6-4
160386	Resistor (1000 Ohms) 6-4	161207	Cable Assembly 6-11
161150**	Cabinet, Test 6-2	161208	Cover 6-11
161153	Plate, Motor 6-8	161209	Washer, Flat 6-2
161155	Gear (24T) 6-8	161210	Nut (11/16-32 Hex) 6-4
161156	Ring 6-2	161211	Cable Assembly 6-10
161157	Bracket 6-6	161212	Resistor (22000 Ohms) 6-10
161158	Shaft W/Bearing, Upper 6-6,6-7	161213	Capacitor (16 MF) 6-10
161159	Shaft W/Bearing, Lower 6-6	161214	Socket, Lamp 6-9
161161	Gear (48T) 6-6	161215	Lamp, Glow 6-2,6-9
161163	Sleeve 6-6	161217	Rectifier and Cable Assembly 6-10
161164	Post 6-6	161218	Holder, Bulb 6-2
161165	Cam, Contact 6-6	161219	Knob, Finger 6-2
161166	Bracket, Brush 6-6	161220	Disk 6-9
161167	Strip, Insulator 6-6	161221	Cable Assembly 6-5
161168	Strip, Insulator 6-6	161236	Gear (11T) 6-3
161169	Plate 6-6	161238	Connector, Receptacle (36 PT) 6-14
161170	Bracket, Contact 6-6	161239	Connector, Plug (36 PT) 6-12
161172	Bracket, Resistor 6-4	161595	Connector, Receptacle (36 PT) 6-13
161173	Post 6-5	161877	Plate 6-2
161174	Bracket 6-5	162356	Rectifier (500 MA) 6-10
161175	Bracket, Rectifier 6-2	162357	Capacitor (500 MF) 6-10
161176	Shield 6-2	162358	Diode, Silicon 6-10
161178	Panel W/Hinge, Rear 6-2	162359	Transformer 6-10
161179	Panel W/Pins, Rear 6-2	162360	Fuse (9/10 Amp) 6-10
161181	Plate 6-4	163579	Bracket 6-6
161182	Plate 6-4	163595	Gear (24T) 6-8
161183	Plate 6-4	163651	Cable Assembly 6-11
161184	Plate 6-4	163652	Cable Assembly 6-12
161185	Plate 6-4	163653	Cable Assembly 6-11
161186	Bushing, Guide 6-2	163654	Cable Assembly 6-13
161187	Bushing, Eccentric 6-5	163655	Cable Assembly 6-12
161188	Brush Assembly 6-6	163656	Cam, Contact 6-6
161189	Bracket, Cable Storage 6-2	163657	Bracket 6-12
161190	Plate 6-5	163658	Bracket 6-12,6-13
161192	Handle W/Covers 6-2	163659	Cover 6-12,6-13
161193	Switch, Rotary 6-4	163660	Cover 6-12
161194	Switch, Rotary 6-4	163661	Plate 6-4
161195	Switch, Rotary 6-4	163662	Plate 6-4
161199	Cable Assembly 6-11	164907	Cable Assembly 6-13
161200	Motor, Synchronous - 1/100 H.P., 115 Volts, 60 Cycle, Single Phase 6-8	165116	Terminal 6-10,6-14
161201	Hub W/Ring 6-9	171554	Connector, Plug (50 PT) 6-3
161202	Contact Assembly 6-6	171555	Connector, Plug (50 PT) 6-14
161203	Cable Assembly 6-5		
161205	Fuse (1 Amp) 6-5		