



Bulletin 276B

TECHNICAL MANUAL  
MODEL 28 RECEIVING SELECTOR SET  
(LRS)

SECTIONS

1. DESCRIPTION
2. INSTALLATION
3. ADJUSTMENTS
4. DISASSEMBLY
5. LUBRICATION
6. PRINCIPLES OF OPERATION

**TELETYPE<sup>®</sup>**  
**CORPORATION**  
SUBSIDIARY OF *Western Electric Company* INC.  
SKOKIE, ILLINOIS, U.S.A.



## LIST OF EFFECTIVE PAGES

OCTOBER, 1962

PAGE NUMBER	CHANGE IN EFFECT
A to C	ORIGINAL
1-1 to 1-2	ORIGINAL
2-1 to 2-3	ORIGINAL
3-1 to 3-30	ORIGINAL
4-1 to 4-2	ORIGINAL
5-1 to 5-8	ORIGINAL
6-1 to 6-11	ORIGINAL

The above list indicates the effective pages as of the date of issue. Upon receipt of change pages, insert them numerically and discard any superseded pages.

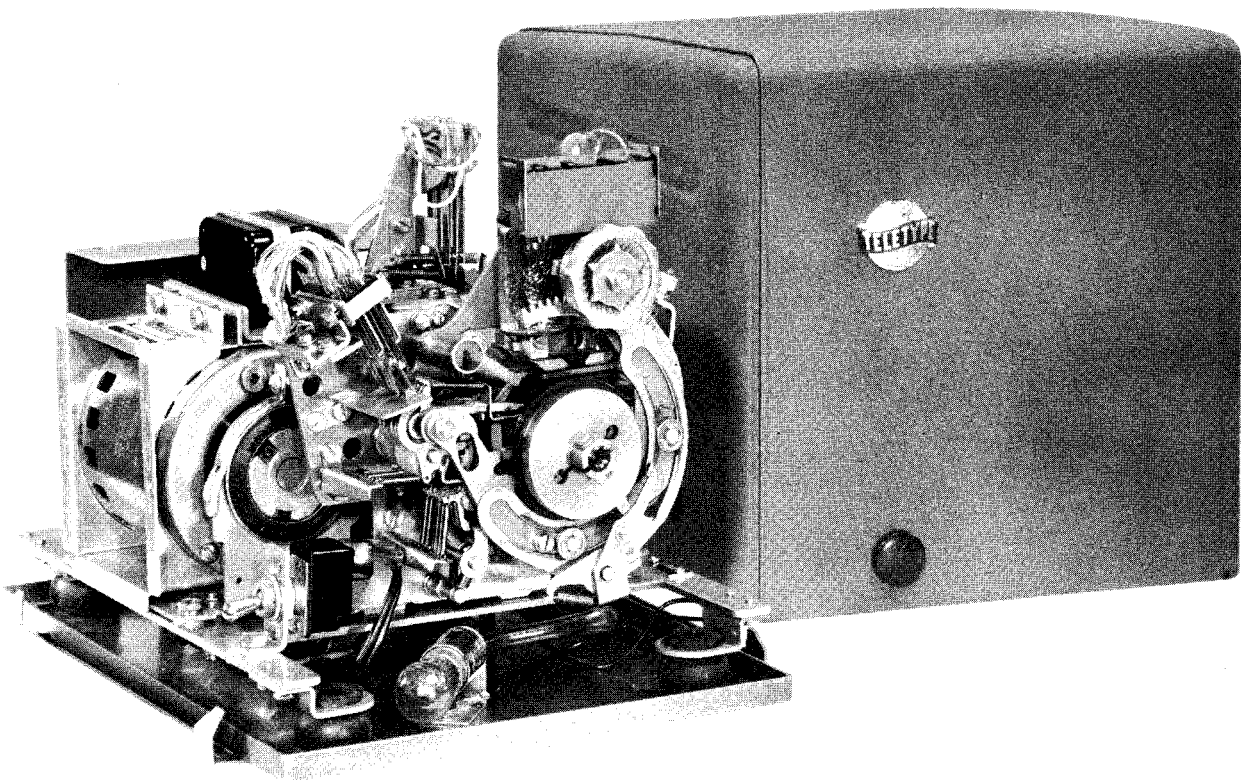

RECEIVING SELECTOR SET (LRS)

## TABLE OF CONTENTS

Paragraph	Page	Paragraph	Page
FRONT MATTER		SECTION 4 - DISASSEMBLY	
List of Effective Pages	A	4-1. INTRODUCTION	4-1
Receiving Selector Set - Photograph	B	4-2. GENERAL DISASSEMBLY INSTRUCTIONS	4-1
Table of Contents	C	4-3. COVER	4-1
SECTION 1 - DESCRIPTION		4-4. RECEIVING SELECTOR (LRS)	4-1
1-1. INTRODUCTION	1-1	a. Removal from Base	4-1
1-2. GENERAL DESCRIPTION	1-1	b. Selector Mechanism Removal	4-1
1-3. BASE	1-1	c. Main Shaft Removal	4-2
1-4. MOTOR UNIT	1-1	d. Main Plate Assembly Removal	4-2
1-5. RECEIVING SELECTOR	1-1	4-5. MOTOR UNIT	4-2
1-6. GEAR SETS	1-2	SECTION 5 - LUBRICATION	
1-7. TECHNICAL DATA	1-2	5-1. INTRODUCTION	5-1
a. General	1-2	5-2. GENERAL LUBRICATION INFORMATION	5-1
b. Standard Speeds	1-2	5-3. LUBRICATION	5-2
c. Selector Magnet Coil Specifications	1-2	a. Function and Selector Clutch	5-3
d. Contact Ratings	1-2	b. Function Cam and Clutch Trip Mechanism	5-3
e. Motor Data	1-2	c. Oil Reservoir	5-3
f. Base	1-2	d. Main Shaft	5-4
g. Physical Data	1-2	e. Timing Contact Bails	5-4
SECTION 2 - INSTALLATION		f. Range Finder Mechanism	5-5
2-1. INTRODUCTION	2-1	g. Selector Lever and Springs	5-6
2-2. UNPACKING	2-1	h. Actuator Latches and Springs	5-7
2-3. ASSEMBLY OF SET	2-1	i. Motors and Gears	5-8
2-4. MOUNTING OF SET	2-1	SECTION 6 - PRINCIPLES OF OPERATION	
2-5. ELECTRICAL CONNECTIONS	2-1	6-1. INTRODUCTION	6-1
2-6. PREPARATION FOR OPERATION	2-2	6-2. CODE	6-1
SECTION 3 - ADJUSTMENTS		6-3. RECEIVING SELECTOR SET OPERATION	6-1
3-1. INTRODUCTION	3-1	a. Summary of Operation	6-1
3-2. GENERAL MAINTENANCE INFORMATION	3-1	b. Motor Unit	6-1
3-3. GENERAL ADJUSTMENT INFORMATION	3-1	c. Receiving Selector	6-3
3-4. ALPHABETICAL INDEX: ADJUSTMENTS AND SPRING TENSIONS	3-2	(1) Selecting Mechanism	6-3
3-5. ADJUSTMENTS AND SPRING TENSIONS	3-3	(2) Transfer Mechanism	6-6
3-6. CODE READING AND TIMING CONTACT STROBING PROCEDURE	3-28	(3) Code Reading Contact Assembly	6-6
		(4) Orientation	6-7
		(5) Function Cam-Clutch and Clutch Trip Assembly	6-8
		(6) Timing Contact Mechanism	6-8
		(7) Selector and Function Clutch Operation	6-8



## SECTION 1

## DESCRIPTION

## 1-1. INTRODUCTION

a. This manual presents technical information for the Model 28 Receiving Selector Set, an electro-mechanical device designed to convert a sequential telegraphic signal code input into a parallel wire code output.

b. The manual is divided into six sections. Section 1, Description, contains a brief physical and functional description of the equipment, and a listing of pertinent technical data. Section 2, Installation, presents installation information, including assembly instructions and dimensional outline drawings. Section 3, Adjustments, includes all necessary adjustments and spring tension requirements. Section 4, Disassembly, provides instructions to aid in disassembly of the equipment for maintenance purposes. Section 5, Lubrication, shows all necessary lubrication points, and recommended lubrication intervals. Section 6, Principles of Operation, explains how the equipment operates, and includes schematic electrical and operational diagrams.

## 1-2. GENERAL DESCRIPTION

a. The Model 28 Receiving Selector Set is an electro-mechanical device designed to convert an incoming start-stop sequential telegraphic signal into a parallel wire signal output. The unit is capable of operating at speeds of 60, 75, or 100 WPM (depending on the gear set used) and is designed to accept neutral start-stop signals. Available models of the Set will handle either 5 level or 8 level code.

b. The basic components of the Receiving Selector Set are a Base (LRSB), a Receiving Selector (LRS), and a Motor Unit (LMU). The Receiving Selector and Motor Unit mount on the Base, and are mechanically coupled through an intermediate gear set.

c. Parts ordering information is available in Teletype Bulletin 1185B. The illustrations in 1185B are also useful when disassembling the unit, and for maintenance purposes. All tools required for maintenance and adjustment of the Set are listed in Teletype Bulletin 1124B.

## 1-3. BASE

a. The Base (LRXB) provides mounting, electrical, and cover facilities for the Receiving Selector (LRS) and Motor Unit (LMU). It includes the following features:

(1) An oil pan, or sub-base, to catch any oil or grease which may be thrown off or drip from the mounted units.

(2) A base plate to provide mounting facilities.

(3) Vibration dampers and rubber feet to minimize mechanical transmission of noise, and to prevent scratching of the mounting surface.

(4) A gear guard for protection of maintenance personnel.

(5) A dust cover.

(6) An on-off motor control switch, and a fuse for protection of the power circuit.

(7) Terminal block and plug-in facilities for electrical connection of power line and ground.

(8) A power-on indicator lamp.

b. The Base is also capable of mounting, in place of a Receiving Selector, a Model 28 (LD) Sending Distributor. For descriptive and technical information concerning this unit, refer to Teletype Bulletin 234B.

## 1-4. MOTOR UNIT

The Motor Unit (LMU) provides the motive power necessary to operate the Receiving Selector. The Motor Unit mounts on the Base, and is mechanically coupled to the Receiving Selector through an intermediate gear assembly. The Motor Unit is a complete assembly, and includes a thermal cutout switch and starting capacitor mounted on a motor bracket.

## 1-5. RECEIVING SELECTOR

a. The Receiving Selector (LRS) converts the incoming sequential telegraphic code into parallel wire output. This unit is supported by a metal frame casting which mounts to the base plate by means of three screws. A gear on the rear of the main shaft mates with the intermediate driving gear on the base. All electrical signal wiring terminates in a 36 point female connector mounted at the rear of the base, beneath the base plate. In addition to the above features, the Receiving Selector also includes the following:

(1) A selector mechanism to receive

the incoming signals electrically and, through mechanical linkages, operate the code reading contacts on which the outgoing signal is stored.

(2) A selector clutch and cam assembly to control operation of the selector mechanism linkages.

(3) A function clutch and cam mechanism to control operation of the timing contacts.

(4) A timing contact assembly consisting of two sets of transfer contacts operated by a bail and spring mechanism, and controlled via rotation of the function cam assembly.

b. The main shaft assembly extends from the front to rear of the unit, and is supported by two bearings mounted in the frame casting. The main shaft rotates continuously as long as power is supplied to the motor. Both the selector and function cam assemblies are connected to the main shaft through their respective clutch assemblies.

1-6. GEAR SETS

Alternate gear sets are available to operate the Set at speeds of 60, 75, or 100 WPM. These gear sets serve to couple the rotary motion from the Motor Unit to the Receiving Selector main shaft. They are not included as part of the base, and must be ordered separately. See Teletype Parts Bulletin 1185B for parts ordering information.

1-7. TECHNICAL DATA

a. General - The data presented is for a typical Receiving Selector Set, and may vary for individual units.

b. Standard Speeds

Depending on gear set\* used:

<u>WPM</u>	<u>OPM</u>
60	368
75	460
100	600

\*Refer to Bulletin 1185B for gear set part ordering numbers.

c. Selector Magnet Coil Specifications

Individual coil resistance -- 132 ohms

Coil Operating Current:

Series connected -- 20 ma.

Parallel connected -- 60 ma.

d. Contact Ratings

Code Reading Contacts:

Current carrying capacity -- 60 ma. at 110 v. D. C.

Timing Contacts:

Breaking current\* -- 100 ma. at 110 v. D. C.

\*With arc suppression. Arc suppressors are not included as part of the Set.

e. Motor Data

Type	Synchronous
Speed	3600 RPM
Input Voltage	Single Phase, 115 v. $\pm$ 10% A. C.
Frequency	60 cycles (only) $\pm$ 0.75%
Input Current	
Starting	5.0 amperes
Running (no load)	1.06 amperes
Running (full load)	1.25 amperes
Power Output	25 milli-horsepower
Protection	Thermal Cutout
Power consumption	75 watts
Heat Dissipation	53 watts
Starting Capacitor	88 - 108 MFD

f. Base

Fuse rating	2.0 amps at 125 v.
Lamp rating	6 watts at 125 v., Bayonet type
Switch rating	6.0 amps at 125 v., Toggle type 3.0 amps at 250 v.

g. Physical Data

Dimensions:

Height	8-1/16 inches
Depth	9-3/4 inches
Width	7-13/16 inches
Weight (unpacked)	16-1/2 pounds



## SECTION 2

### INSTALLATION

#### 2-1. INTRODUCTION

The purpose of this section is to provide instructions for the assembly and installation of the Receiving Selector Set. The installation procedures require the performance of several operations to install each component of the Set. It is recommended that the components be installed in the order of presentation in this section.

#### 2-2. UNPACKING

a. The equipment is packed for maximum protection. However, due caution must be taken in unpacking and handling it to prevent damage and ensure personal safety. All containers are clearly marked as to their contents. While unpacking, observe all caution labels and instructions. All small boxes, bags, and loose parts should be kept with their associated apparatus until used in the installation.

b. Unpack the Base (LRXB), Motor Unit (LMU), and Receiving Selector (LRS). Also unpack the motor pinion and intermediate driven gear combination ordered for the desired operating speed.

#### NOTE

See Teletype Bulletin 1185B. The motor pinion and intermediate driven gears are not included as part of the Base, and must be ordered separately.

#### 2-3. ASSEMBLY OF SET (Figure 2-2)

a. Mount the 178996 and 178997 Connector brackets to the undersurface of the base plate, at the rear of the base. To secure the brackets, use four of the 151632 screws and 2191 lock washers packed in the muslin bag attached to the base. Make sure the connectors are mounted properly to accept the LD or LRS connector, depending on the unit to be used.

b. Secure the intermediate driven gear to the intermediate shaft assembly with the two remaining 151632 screws and 2191 lock washers supplied.

c. Place the 156805 rubber pinion retainer over the shoulder of the motor pinion gear (see note in paragraph 2-2.b.). Secure the motor pinion gear to the motor shaft with the two 156806 retainer posts found in the muslin bag attached to the base.

d. Assemble the motor unit on the base

using the four screws, lock washers, and flat washers supplied. Position the flat washers between the motor bracket and the base plate. Refer to Section 3, Adjustments, for clearance requirements between the motor pinion and intermediate driven gears. Route the power cable from the motor unit, under the base plate, and up through the hole immediately to the left of the 4-point terminal block (see Figure 2-2). Connect the leads to terminals 3 and 4 (see wiring diagram 4705WD shipped with the Base).

e. To mount the Receiving Selector (LRS) on the base, route the cable assembly (with connector) down through the rectangular hole in the base plate nearest the left rear corner of the 4-point terminal block. Direct the cable assembly under the base plate to the rear of the set. Secure the 36-point connector to the connector brackets using the two screws and lock washers supplied. Secure the Receiving Selector to the base using the mounting screws, lock washers, and flat washers found in the muslin bag attached to the selector. Refer to Section 3, Adjustments, for clearance requirements between the intermediate driving gear and the Receiving Selector driven gear.

#### NOTE

If a Sending Distributor (LD) is to be mounted on the base in place of a Receiving Selector, follow all but the cable assembly routing instructions outlined above. The Sending Distributor cable assembly should be routed down between the base plate front extensions and then under the base plate to the rear of the base. Secure the connector to the connector brackets (refer to paragraph 2-3.a.).

f. Mount the gear guard in place at the rear of the base, securing it with two 151630 screws and 2191 lock washers. Insert the indicator lamp into its socket.

#### 2-4. MOUNTING OF SET

Prepare a permanent operating location of sufficient size to accept the Receiving Selector Set (see Figure 2-1). The oil pan includes a rubber foot and vibration mount at each corner. These parts serve to prevent scratching the mounting surface, and minimize the mechanical transmission of noise.

#### 2-5. ELECTRICAL CONNECTIONS

Make the necessary electrical signal and power connections to the Set. Refer to the 4705WD and 4706WD wiring diagrams shipped

with the equipment, to determine wiring requirements for the mating power and signal connectors. See paragraph 1-7. c. through f. for pertinent electrical power and current requirements.

2-6. PREPARATION FOR OPERATION

a. Lubrication - Lubricate the Set before placing it into operation. Refer to Section 5 for lubrication instructions. Observe special care to keep all electrical contacts free from oil and grease. Do not over-lubricate the equipment.

b. Adjustments - The Set has been factory adjusted, and should be ready for operation as soon as the initial lubrication and wiring instructions have been followed (refer to paragraphs 2-5. and 2-6. a. above). Operate the set manually, before applying power, and check for freedom of movement and binding between parts.

CAUTION

Improperly adjusted equipment may be damaged in a matter of seconds if operated under power.

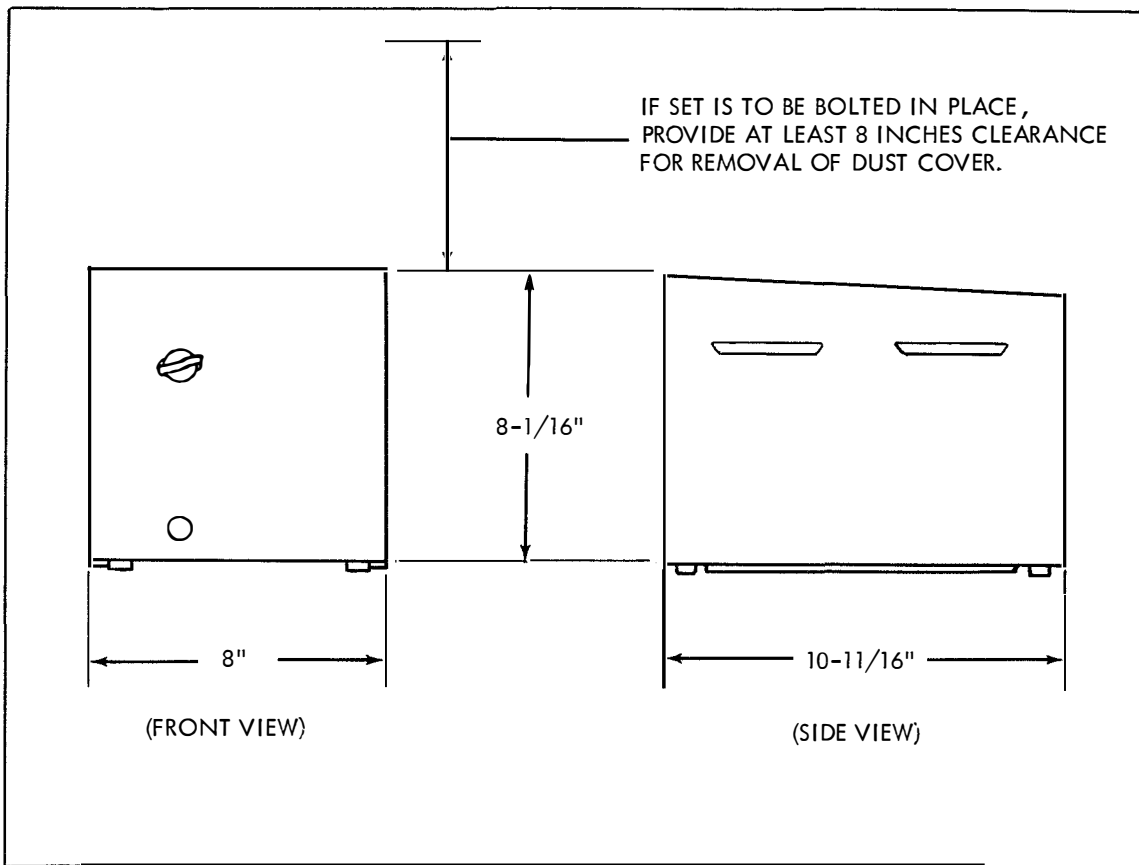

FIGURE 2-1. SET SPACE REQUIREMENTS

CONNECTOR BRACKET  
POSITIONS FOR:

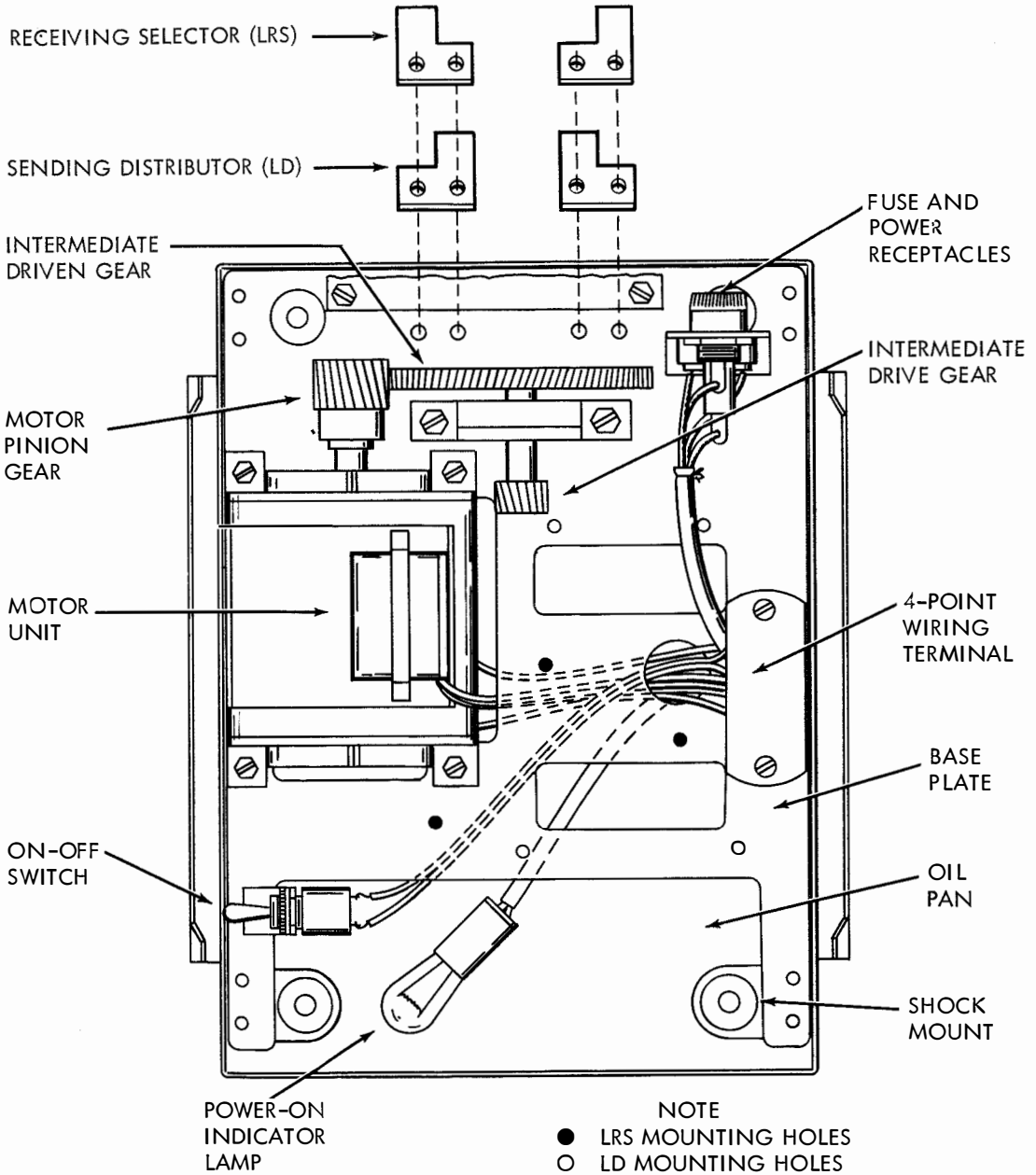

FIGURE 2-2. CABLE ROUTING AND COMPONENTS LAYOUT



## SECTION 3

## ADJUSTMENTS

## 3-1. INTRODUCTION

This section contains adjustment information necessary for proper maintenance of the Receiving Selector Set, and strobing information for proper adjustment of the code reading and timing contacts. It is assumed that the mechanisms illustrated in this section are being viewed from a position in front of the equipment, unless the illustrations are specifically labeled otherwise. In the line drawings, fixed pivot points are shown by solid black circles, and moveable points are shown by cross-hatched circles. References in the text to left, right, front, or rear apply to the unit in its normal operating position when viewed from a point in front of the selector clutch assembly.

## 3-2. GENERAL MAINTENANCE INFORMATION

The Receiving Selector Set should be cleaned and inspected periodically to assure optimum performance and to prevent troubles that might otherwise develop. During inspection, make sure that all contacts are clean and mate properly. Wiring connections should be mechanically secure and nuts and screws that lock adjustments should be tight. Check for abrasion on wiring due to contact with moving parts. Metal dust near any moving part may indicate insufficient clearance, a condition that should be immediately rectified. While cleaning, take care to avoid damaging springs and levers. Exercise caution to avoid putting kinks in contact leaves that might require bending to meet tension requirements. Maintenance may require replacement of parts (disassembly instructions are included in Section 4). It is very important that the Set be thoroughly lubricated at the intervals specified in Section 5.

## 3-3. GENERAL ADJUSTMENT INSTRUCTIONS

a. In the adjustments and spring tensions covered in this section, location of clearance, position of parts, and point and angle of scale applications are illustrated by drawings. A complete adjusting procedure should be read before making the adjustment or checking the spring tension. The adjustments are arranged in a sequence that should be followed if a complete readjustment of the unit were undertaken.

b. The spring tensions should be measured with Teletype scales in the positions shown

in the drawings. Springs which do not meet the requirements, and for which there are no adjusting procedures, should be discarded and replaced by new springs.

c. When rotating the drive shaft gear by hand, rotation is counterclockwise as viewed from a position in front of the selector clutch.

d. When the requirement calls for a clutch to be DISENGAGED, the clutch shoe lever must be fully latched between its trip lever and latch lever so that the clutch shoes release their tension on the clutch drum. When ENGAGED, the clutch shoe lever is unlatched and the clutch shoes are wedged firmly against the clutch drum.

## NOTE

When rotating the main shaft by hand, the function or selector clutch may not fully disengage upon reaching its stop position. To disengage the clutch, rotate it to its stop position, apply a screwdriver to the cam disk stop lug, and move the disk in the normal direction of shaft rotation until the latch lever seats in its notch in the disk.

e. Tools required to make adjustments are not supplied with the equipment, but are listed in Teletype Bulletin 1124B. If parts are removed, all adjustments which the removal of parts might facilitate should be made before the parts are replaced. When a part mounted on shims is removed, the number of shims at each mounting screw should be noted so that the identical shim pile-up can be made when the part is remounted. Unless stated otherwise, all nuts and screws that were loosened should be tightened after an adjustment has been made.

f. The cover may be removed for inspection and minor repair of the components. However, when more extensive maintenance is to be undertaken, it is recommended that the unit be removed from its operating location and the power disconnected.

g. All contact points should meet squarely. Contacts with the same diameter should not be out of alignment more than 25% of the contact diameter. Avoid sharp kinks or bends in the contact springs.

## CAUTION

Improperly adjusted equipment may be seriously damaged in a matter of seconds if operated under power.

3-4. ALPHABETICAL INDEX: ADJUSTMENTS AND SPRING TENSIONS

ADJUSTMENTS	Page	ADJUSTMENTS (Cont.)	Page
Base and Motor Unit	3-26	Probe (Y) and Common (X) Contact Operating Bail Position	3-23
Code Reading Contact Assembly		Range Finder Knob Phasing	3-12
Adjustments		Release Downstop Bracket	3-16
Backstop - Normally Closed		Reset Arm	3-14
Contacts	3-20	Selector Arm	3-5
Normally Open Contact Gap	3-21	Selector Armature Downstop Bracket	3-6
Spring Tension - Normally Closed Contact	3-20	Selector Cam Lubricator	3-8
Spring Tension - Normally Open Contact	3-21	Selector Clutch Drum End Play	3-10
Swinger Spring Tension	3-21	Selector Clutch Stop Arm	3-12
Clutch Shoe Lever	3-3	Selector Magnet Bracket	3-6, 3-7
Code Reading Contact Bracket	3-22	Selector Receiving Margin	3-13
Code Reading Contact Position	3-22	Stripper Bail	3-19
Code Reading Contact Spring		SPRING TENSIONS	
Clearance	3-22	Actuator Latch Spring	3-18
Follower Lever	3-15	Adjusting Arm Spring	3-15
Function Clutch Drum End Play	3-3	Clutch Shoe Lever Spring	3-4
Function Clutch Stop Lever	3-14	Clutch Shoe Spring	3-4
Intermediate Driving and Unit		Function Clutch Latch Lever Spring	3-17
Driven Gear Mesh	3-26	Function Clutch Release Spring	3-16
Latch Lever	3-18	Latch Lever Spring	3-19
Motor Pinion and Intermediate		Main Trip Lever Spring	3-18
Driven Gear Mesh	3-26	Marking Lock Lever Spring	3-9
Motor Shield	3-27	Operating Bail Springs	3-25
Oil Shield	3-8	Push Lever Reset Bail Spring	3-11
Timing Contact Assembly		Selector Armature Spring	3-9
Adjustments		Selector Clutch Latch Lever Spring	3-11
Contact Bracket	3-25	Selector Lever Spring	3-10
Normally Closed Contact Gap	3-24	Selector Push Lever Spring	3-10
Normally Closed Contact Pressure	3-24	Spacing Lock Lever Spring	3-11
Normally Open Contact Gap	3-24	Start Lever Spring	3-13
Normally Open Contact Pressure	3-24	Stripper Bail Spring	3-19

## 3-5. ADJUSTMENTS &amp; SPRING TENSIONS

## a. RECEIVING SELECTOR

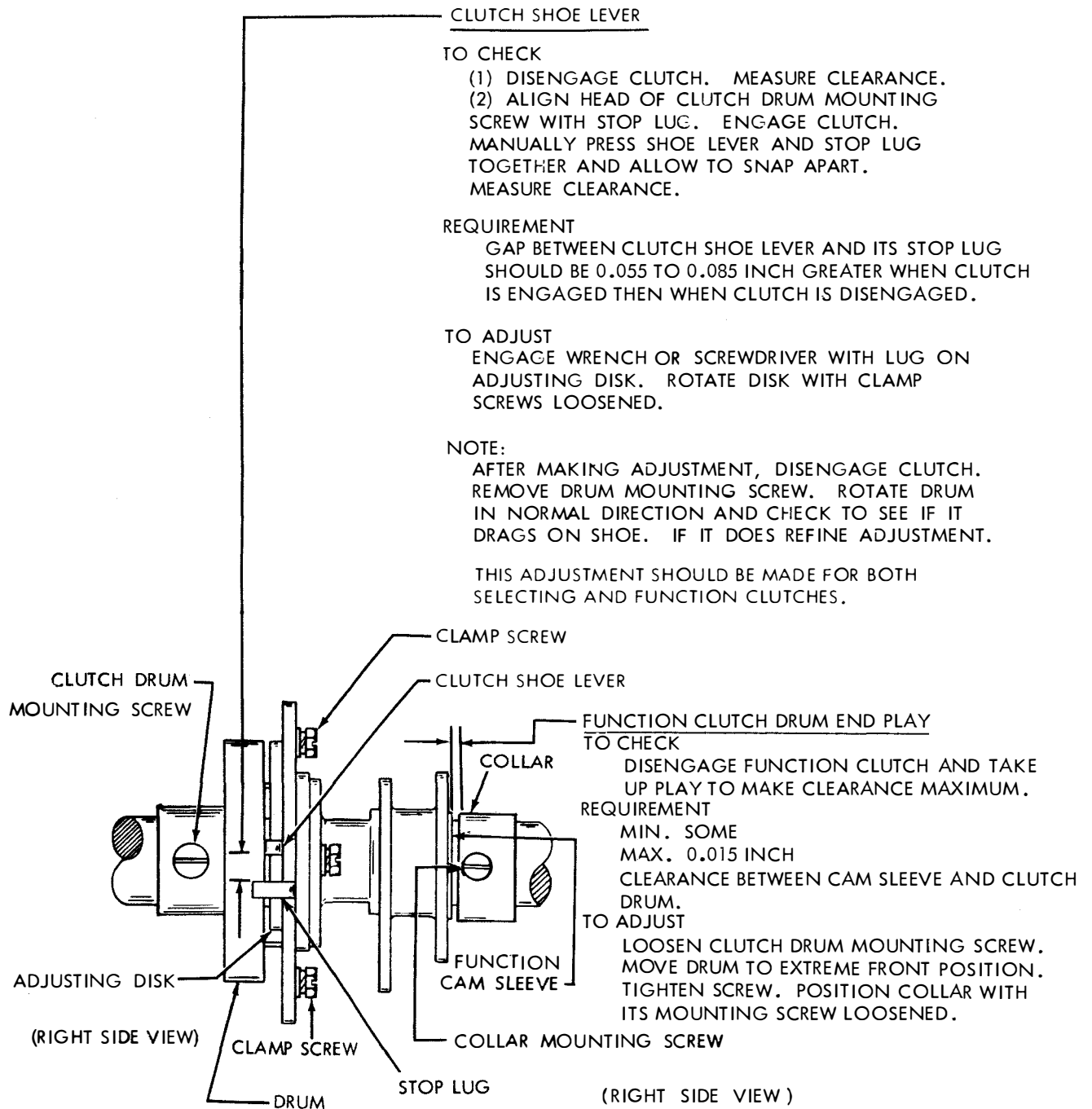

FIGURE 3-1

NOTE:  
THESE SPRING TENSIONS APPLY TO BOTH CLUTCHES.

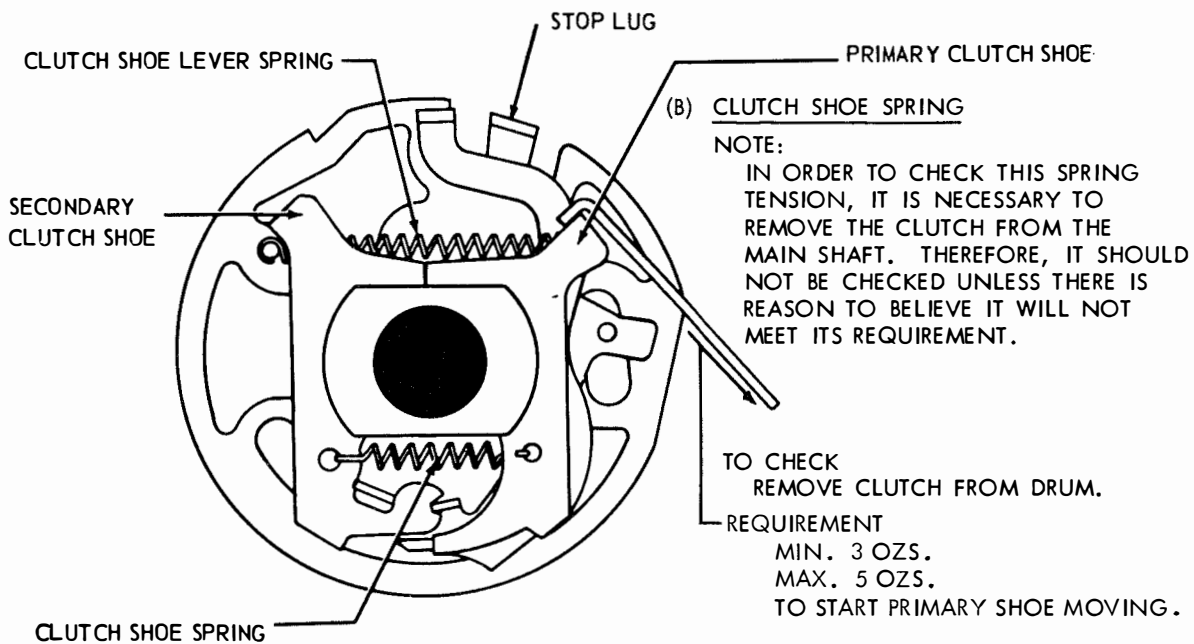
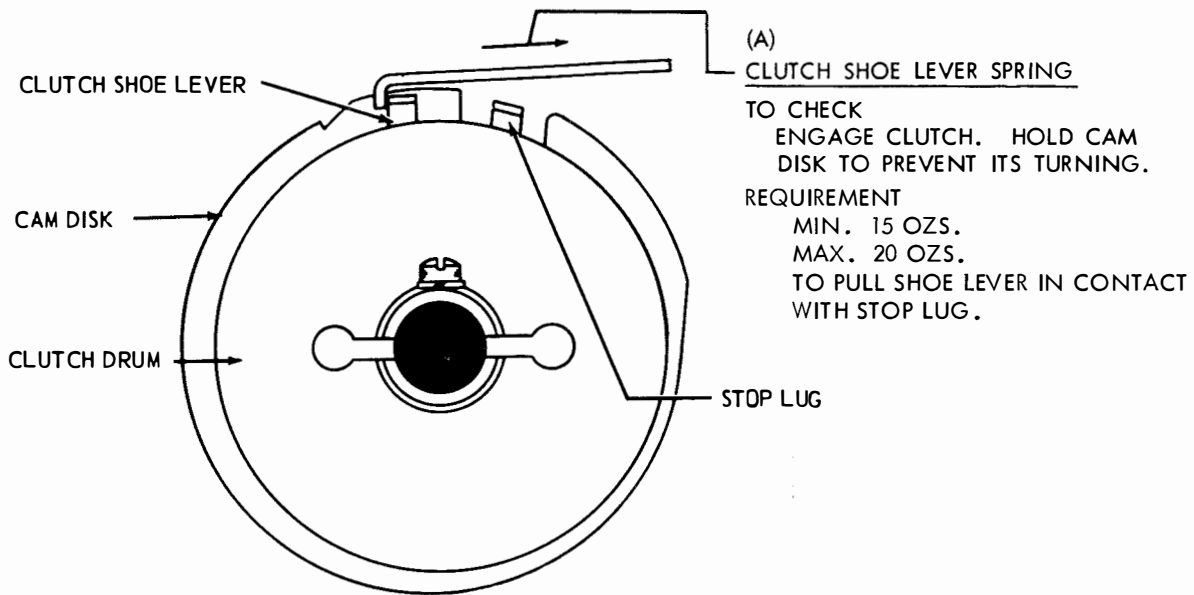

FIGURE 3-2



## NOTE

TO FACILITATE MAKING THE FOLLOWING ADJUSTMENTS, REMOVE THE RANGE FINDER AND SELECTOR MAGNET ASSEMBLIES. TO INSURE BETTER OPERATION, PULL A PIECE OF KS BOND PAPER BETWEEN THE ARMATURE AND THE POLE PIECES TO REMOVE ANY OIL OR FOREIGN MATTER THAT MAY BE PRESENT. MAKE CERTAIN THAT NO LINT OR PIECES OF PAPER REMAIN BETWEEN THE POLE PIECES AND ARMATURE.

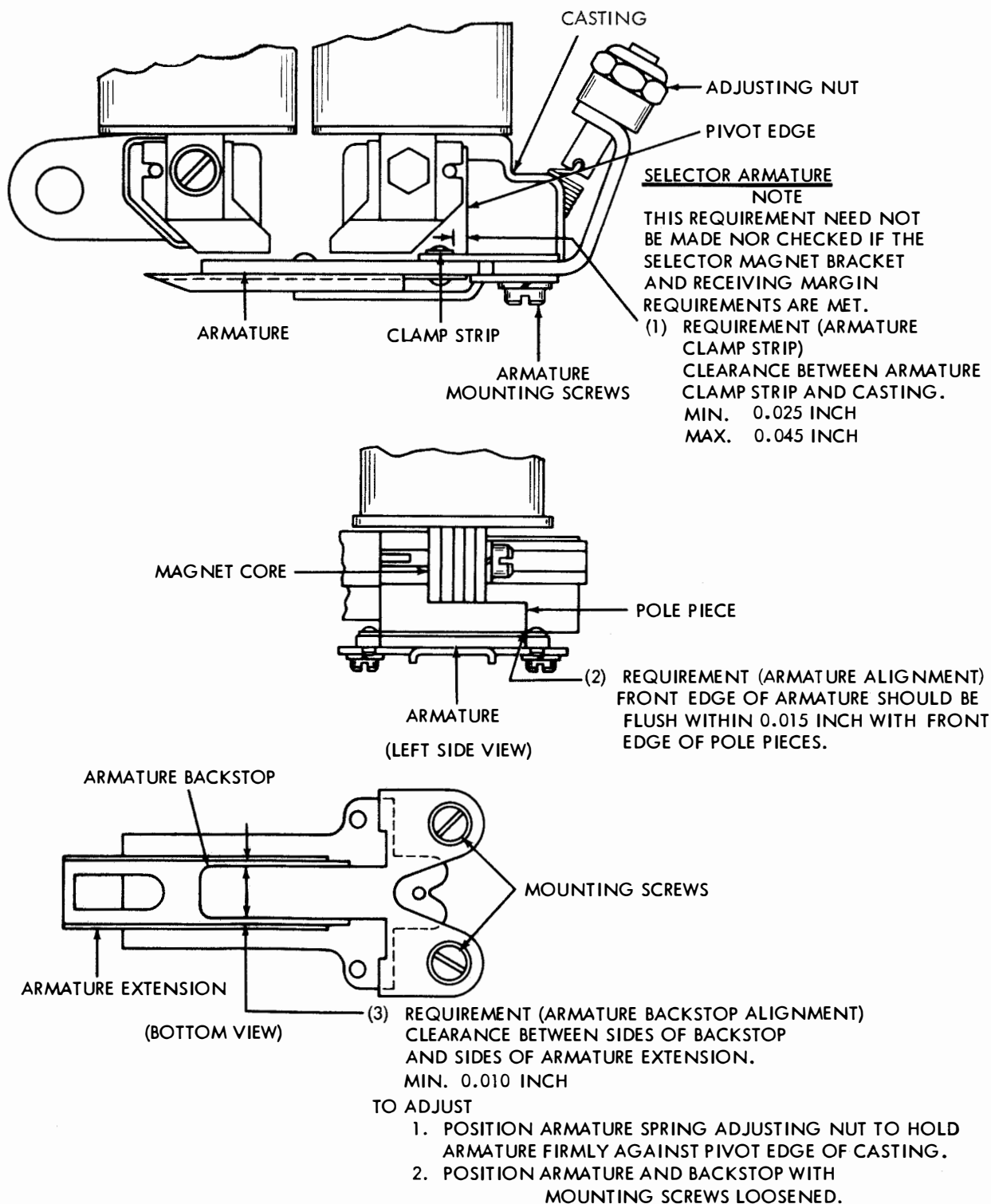

FIGURE 3-3

SELECTOR ARMATURE DOWNSTOP BRACKET

REQUIREMENT

REMOVE OIL SHIELD. WITH MAGNET DE-ENERGIZED, LOCK LEVERS ON HIGH PART OF THEIR CAM, AND ARMATURE RESTING AGAINST ITS DOWNSTOP, CLEARANCE BETWEEN END OF ARMATURE AND LEFT EDGE OF LEFT POLE PIECE.

MIN. 0.025 INCH

MAX. 0.030 INCH

TO ADJUST

POSITION DOWNSTOP BRACKET WITH MOUNTING SCREW LOOSENED. REPLACE OIL SHIELD AND CHECK OIL SHIELD ADJUSTMENT, FIGURE 3-6.

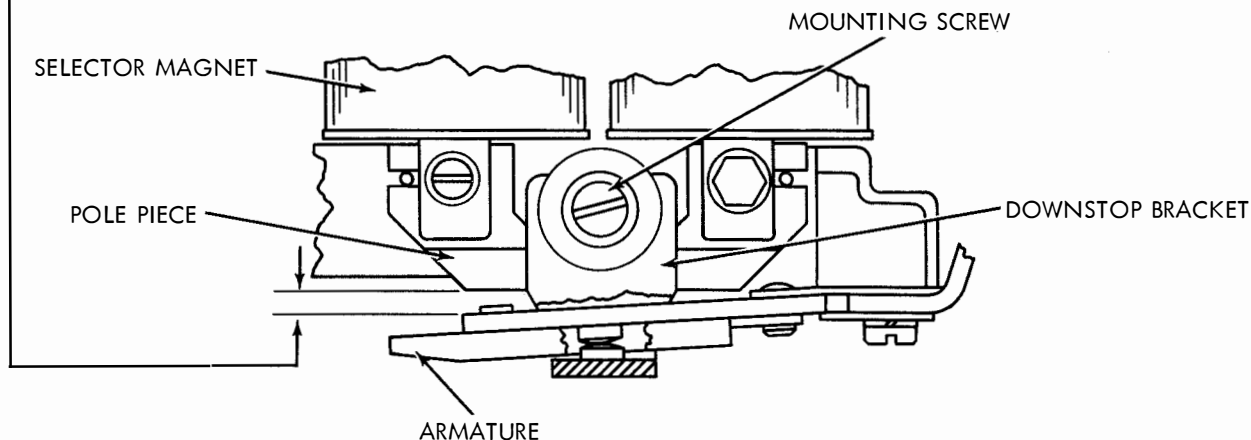

ARMATURE EXTENSION

NOTE  
SEE FOLLOWING PAGE FOR  
REQUIREMENTS (1) AND (2).

SELECTOR MAGNET BRACKET

(3) REQUIREMENT

MARKING LOCK LEVER ON LOW PART OF CAM. MAGNET ENERGIZED. ARMATURE IN CONTACT WITH POLE PIECE. CLEARANCE BETWEEN LOWER SURFACE OF ARMATURE EXTENSION AND UPPER SURFACE OF MARKING LOCK LEVER.

MIN. 0.002 INCH

MAX. 0.005 INCH

TO ADJUST

POSITION UPPER END OF MAGNET BRACKET. TIGHTEN MOUNTING SCREWS AND RECHECK (1).

MARKING LOCK LEVER

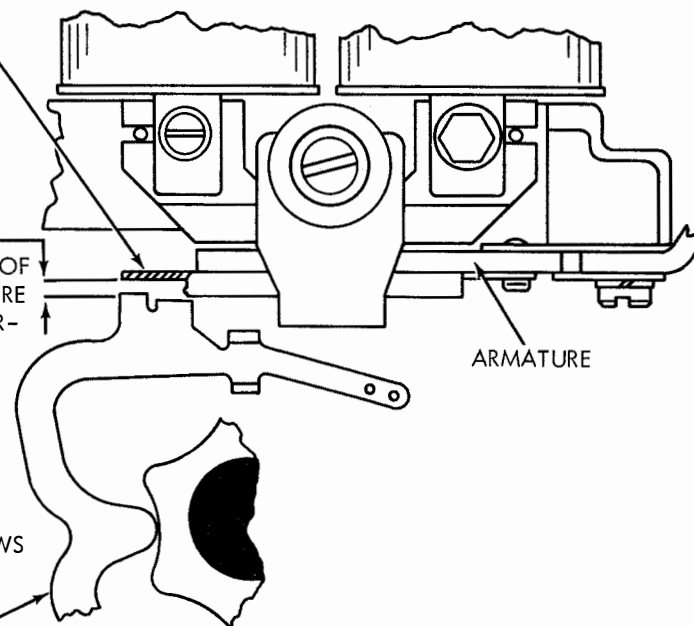
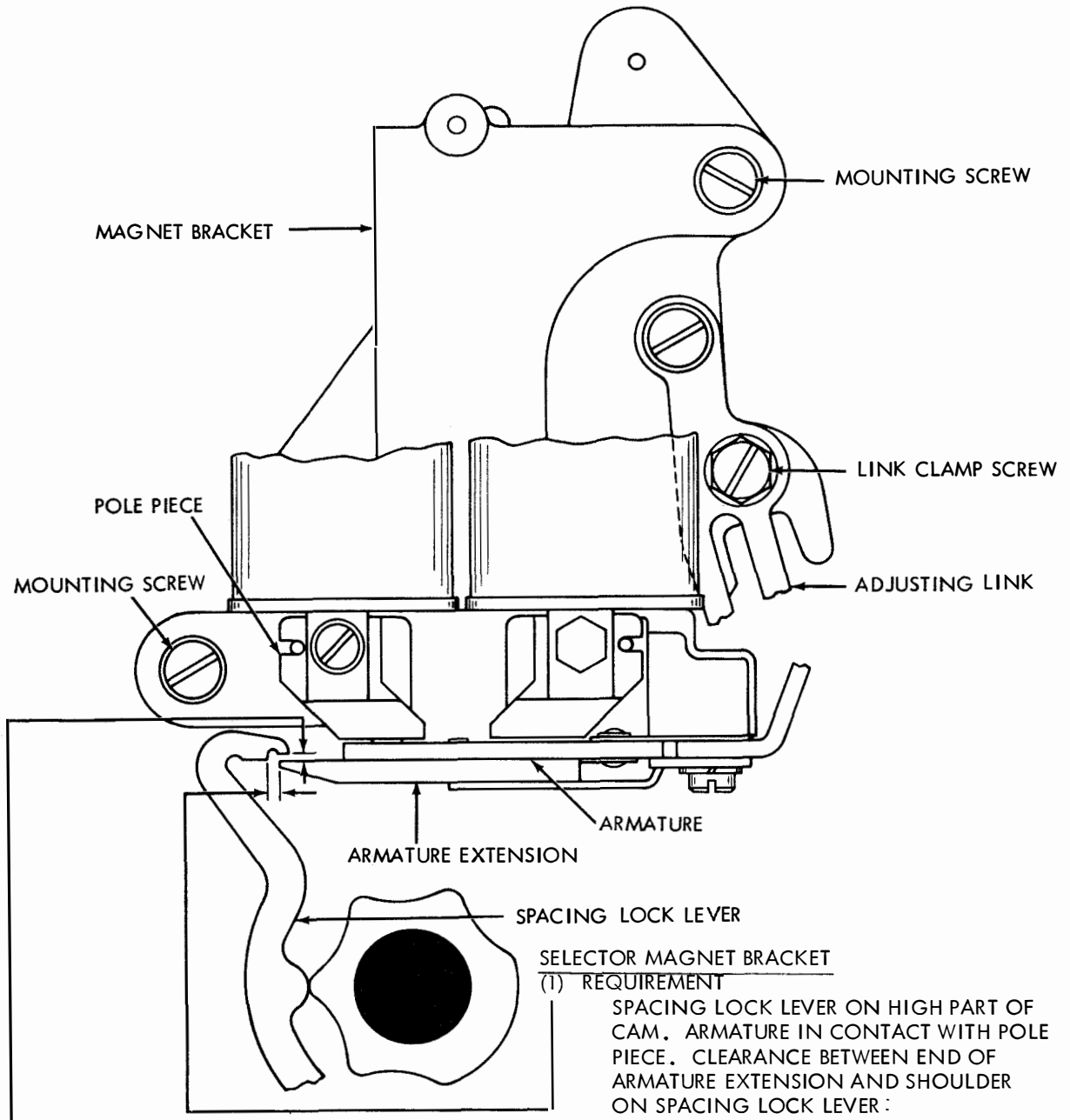

FIGURE 3-4



(2) REQUIREMENT  
 SPACING LOCK LEVER ON HIGH PART OF CAM. ARMATURE IN CONTACT WITH POLE PIECE. SOME CLEARANCE BETWEEN UPPER SURFACE OF ARMATURE EXTENSION AND LOWER SURFACE OF SPACING LOCK LEVER WHEN LOCK LEVER IS HELD DOWNWARD. MAX. 0.003 INCH  
 TO ADJUST  
 POSITION UPPER END OF MAGNET BRACKET. TIGHTEN TWO MAGNET BRACKET MOUNTING SCREWS. RECHECK REQUIREMENT (1).

SELECTOR MAGNET BRACKET  
 (1) REQUIREMENT  
 SPACING LOCK LEVER ON HIGH PART OF CAM. ARMATURE IN CONTACT WITH POLE PIECE. CLEARANCE BETWEEN END OF ARMATURE EXTENSION AND SHOULDER ON SPACING LOCK LEVER:  
 5 LEVEL UNITS  
 MIN. 0.020 INCH  
 MAX. 0.035 INCH  
 8 LEVEL UNITS  
 MIN. 0.012 INCH  
 MAX. 0.030 INCH

TO ADJUST  
 LOOSEN TWO MAGNET BRACKET MOUNTING SCREWS AND ADJUSTING LINK CLAMP SCREW. POSITION MAGNET BRACKET BY MEANS OF ADJUSTING LINK AND TIGHTEN LINK CLAMP SCREW ONLY.

NOTE  
 SEE PRECEDING PAGE FOR REQUIREMENT (3).

FIGURE 3-5

OIL SHIELD REQUIREMENT

- (1) MAGNET DE-ENERGIZED. STOP ARM BAIL FOLLOWER ON LOW PART OF ITS CAM. CLEARANCE BETWEEN START LEVER AND OIL SHIELD: MIN. 0.020 INCH

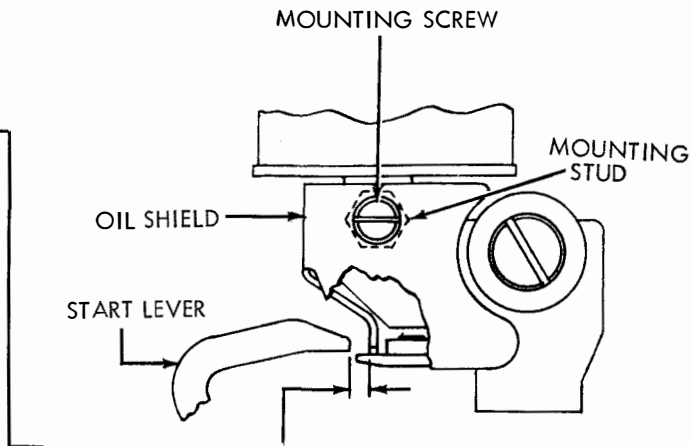

- (2) MAGNET ENERGIZED STOP ARM BAIL FOLLOWER ON HIGH PART OF ITS CAM. CLEARANCE BETWEEN END OF ARMATURE AND OIL SHIELD: MIN. 0.010 INCH

TO ADJUST

POSITION SHIELD WITH MOUNTING SCREW LOOSENED. MAKE SURE OIL SHIELD MOUNTING STUD IS SECURE BEFORE MAKING ADJUSTMENT.

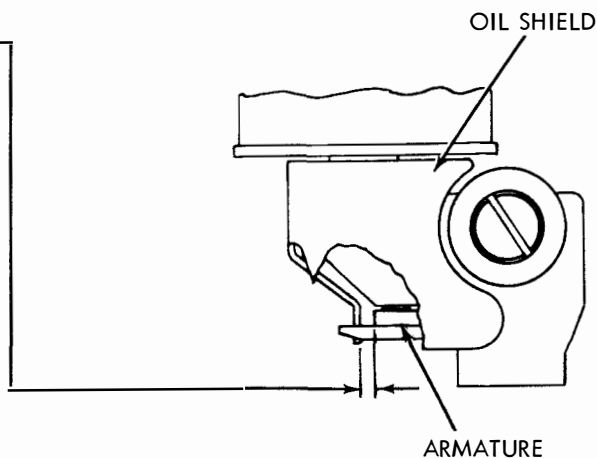

LEATHER WICK

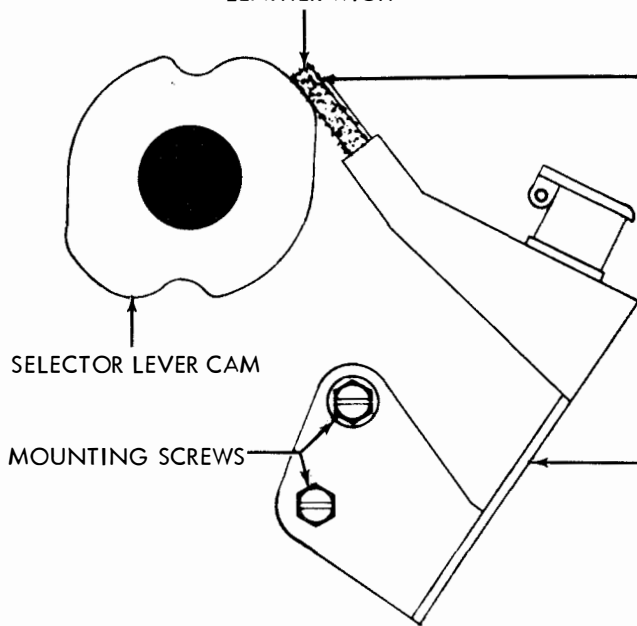

SELECTOR CAM LUBRICATOR REQUIREMENT

HIGH PART OF SELECTOR LEVER CAMS SHOULD CONTACT LEATHER WICK BUT SHOULD NOT DEFLECT WICK MORE THAN 1/32 INCH GAUGED VISUALLY

TO ADJUST

WITH MOUNTING SCREWS FRICTION TIGHT, POSITION LUBRICATOR ASSEMBLY USING LOWER SCREW AS A PIVOT POINT.

FIGURE 3-6

SELECTOR ARMATURE SPRING

REQUIREMENT

MARKING LOCK LEVER, SPACING LOCK LEVER, AND START LEVER ON HIGH PART OF THEIR CAMS. SCALE APPLIED AS NEARLY VERTICAL AS POSSIBLE UNDER END OF ARMATURE EXTENSION.

30 M.A. OPERATION - 1 1/2 OZS. TO 2 OZS.

60 M.A. OPERATION - 2 1/2 OZS. TO 3 OZS.

TO PULL ARMATURE TO MARKING POSITION, IT MAY BE NECESSARY TO READJUST THIS SPRING TENSION WHEN MAKING DISTORTION TOLERANCE TESTS OF THE UNIT.

TO ADJUST POSITION ADJUSTING NUT.

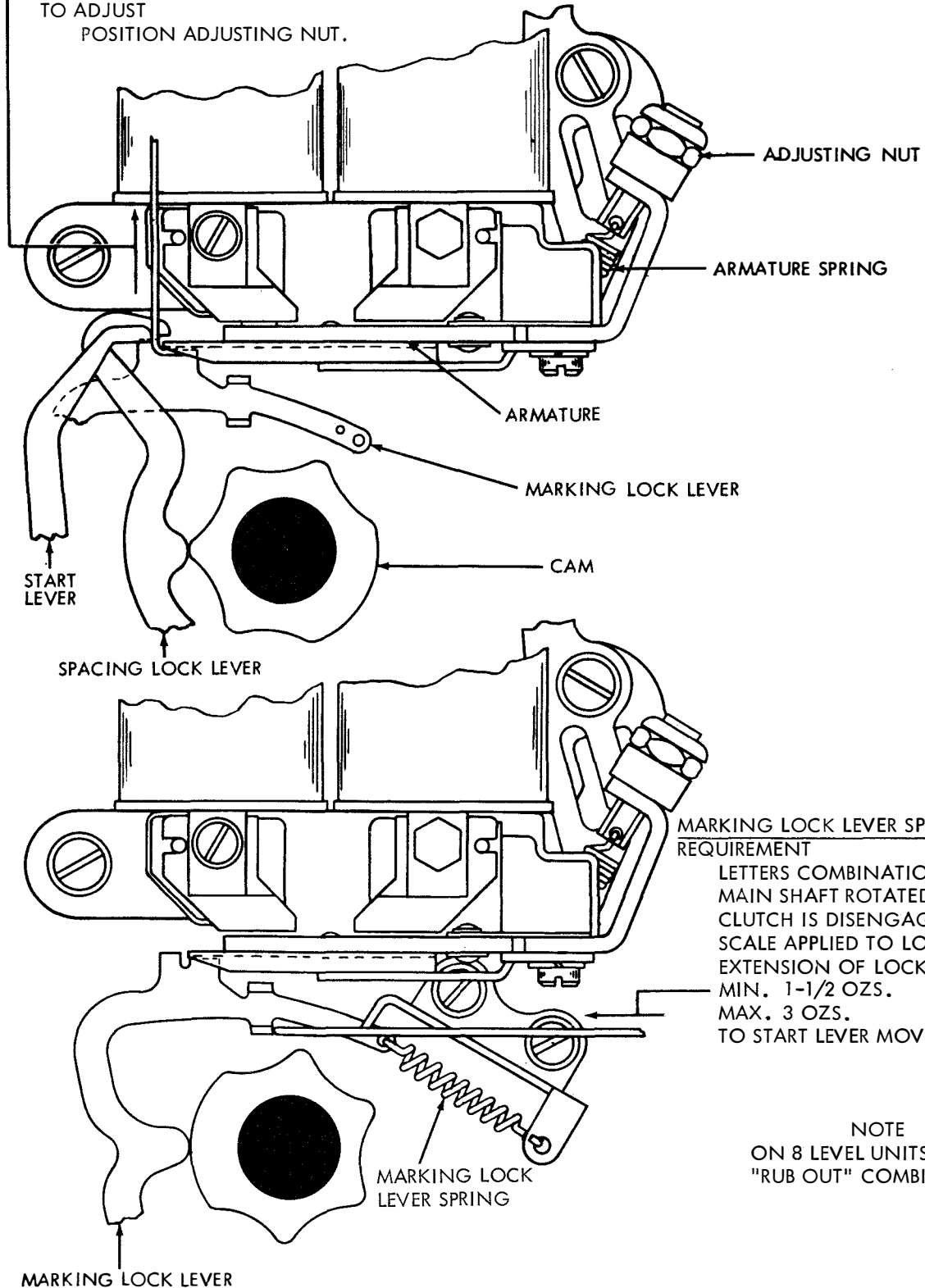

MARKING LOCK LEVER SPRING  
REQUIREMENT

LETTERS COMBINATION SELECTED, MAIN SHAFT ROTATED UNTIL CLUTCH IS DISENGAGED. PUSH SCALE APPLIED TO LOWER EXTENSION OF LOCK LEVER. MIN. 1-1/2 OZS. MAX. 3 OZS. TO START LEVER MOVING.

NOTE  
ON 8 LEVEL UNITS, SELECT "RUB OUT" COMBINATION.

FIGURE 3-7

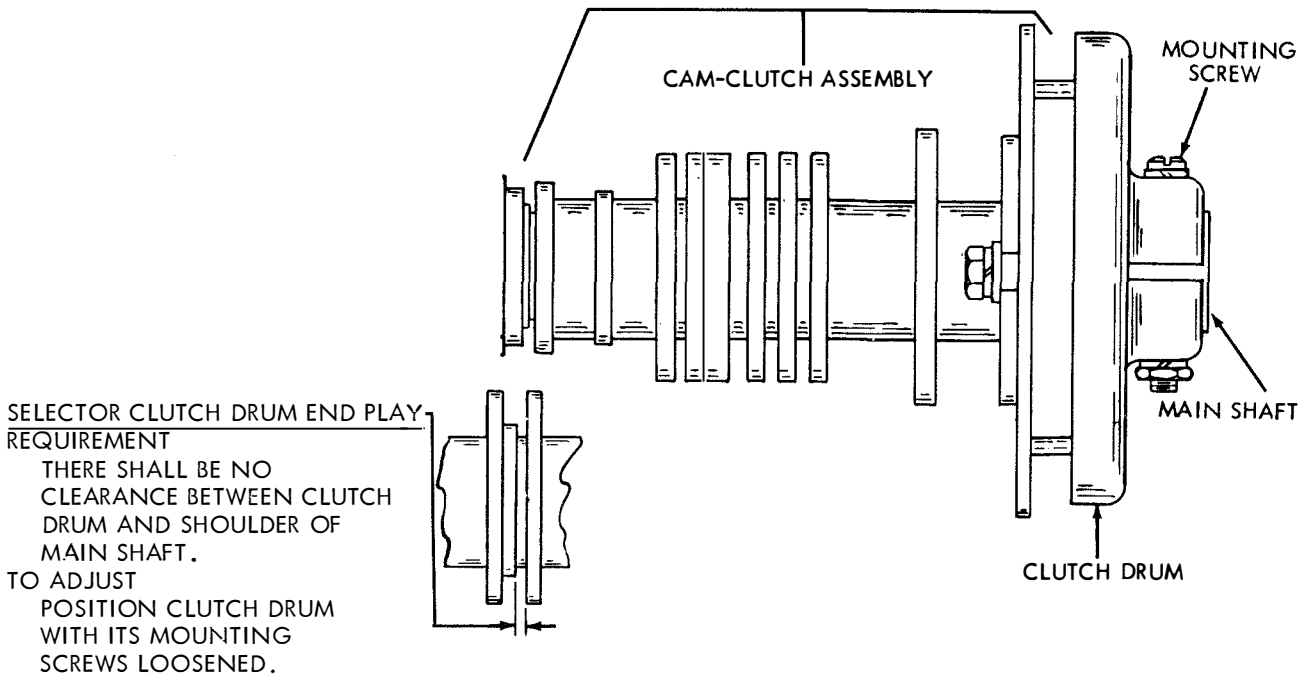
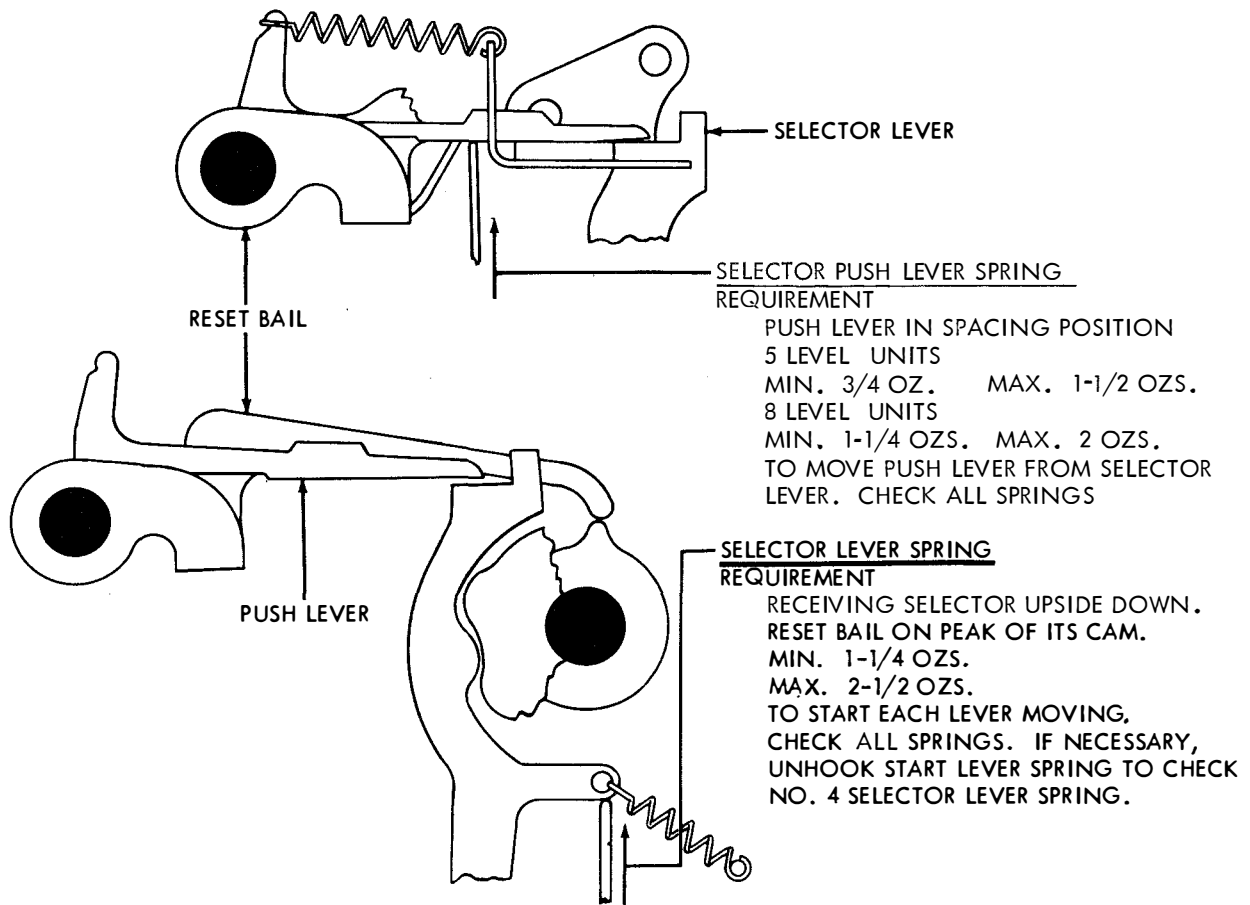

FIGURE 3-8

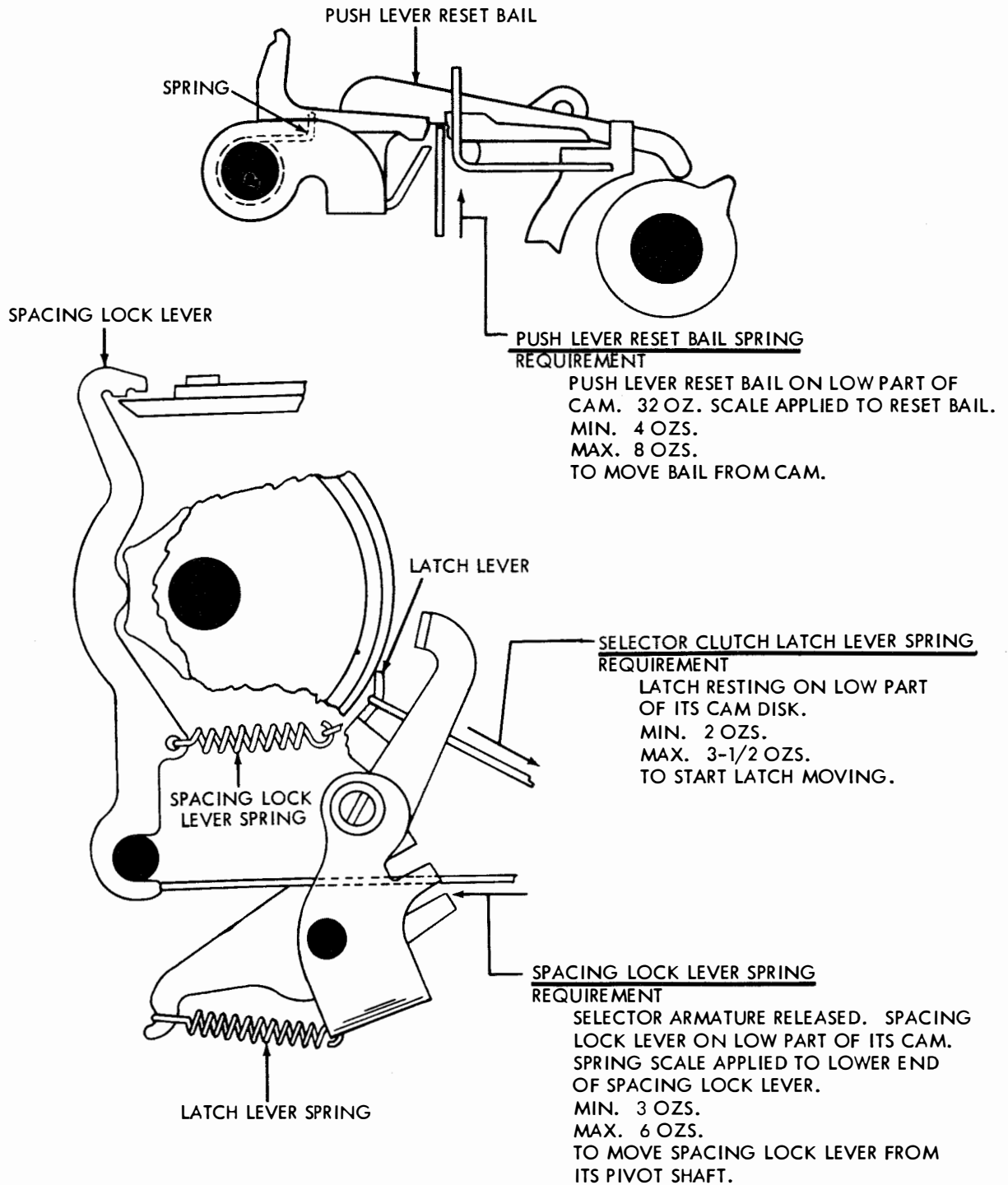

FIGURE 3-9

NOTE: REPLACE RANGE FINDER AND SELECTOR MAGNET ASSEMBLY.

RANGE FINDER KNOB PHASING  
REQUIREMENT

WITH RANGE FINDER KNOB TURNED TO EITHER END OF RACK, ZERO MARK ON SCALE FOR:  
5 LEVEL UNIT SHOULD BE WITHIN + 3 POINTS OF SCRIBED LINE ON RANGE FINDER PLATE.  
8 LEVEL UNIT SHOULD BE IN LINE WITH SCRIBED LINE ON RANGE FINDER PLATE.

TO ADJUST

REMOVE MOUNTING NUT, DISENGAGE KNOB FROM RACK AND POSITION KNOB.  
RE-ENGAGE KNOB WITH RACK AND REPLACE MOUNTING NUT.

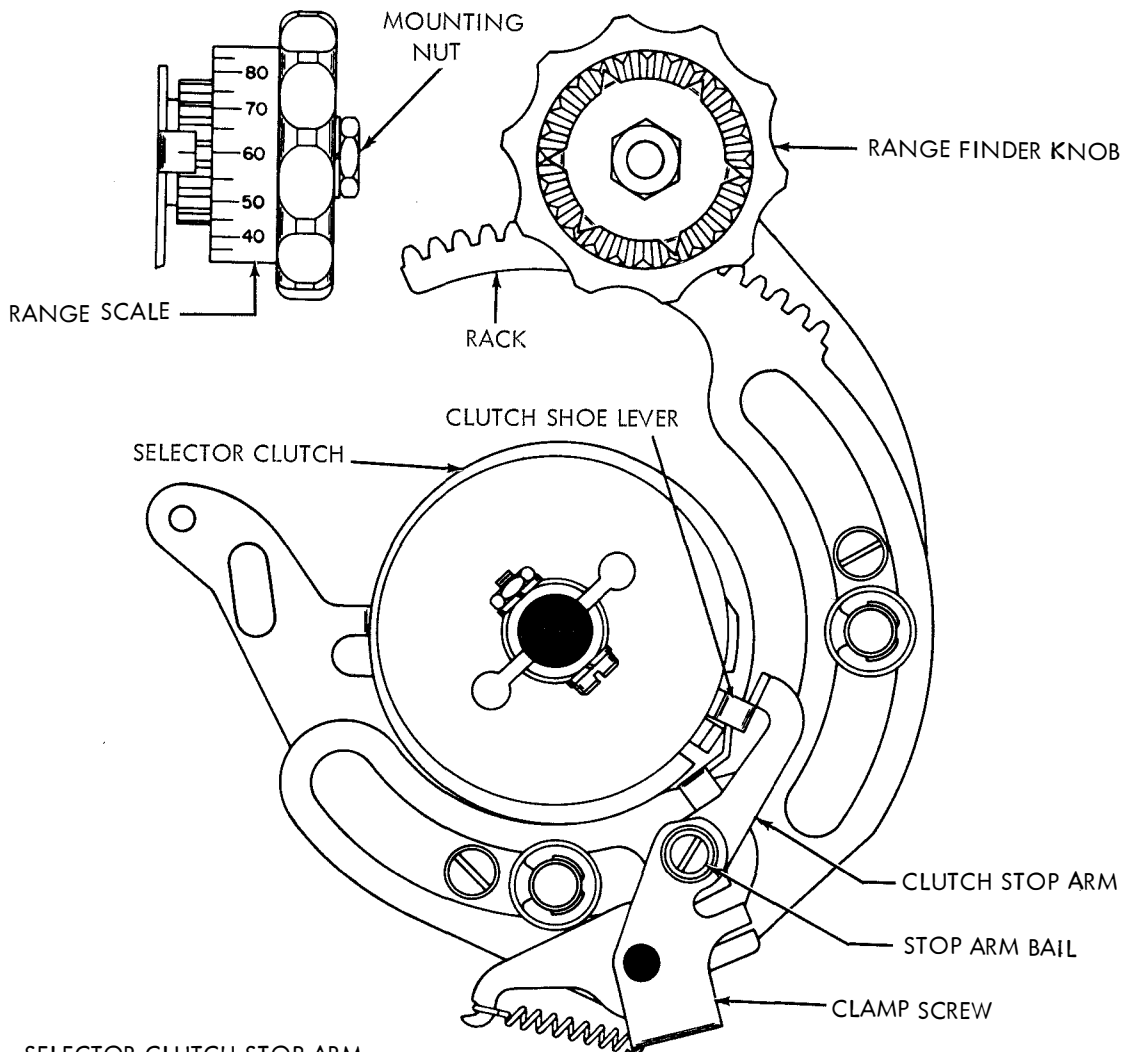

SELECTOR CLUTCH STOP ARM  
REQUIREMENT

RANGE SCALE SET AT 60. SELECTOR CLUTCH DISENGAGED. ARMATURE  
IN MARKING POSITION. CLUTCH STOP ARM SHOULD ENGAGE CLUTCH  
SHOE LEVER BY APPROXIMATELY FULL THICKNESS OF SHOE LEVER.

TO ADJUST

POSITION STOP ARM ON STOP ARM BAIL WITH CLAMP SCREW LOOSENED.

FIGURE 3-10



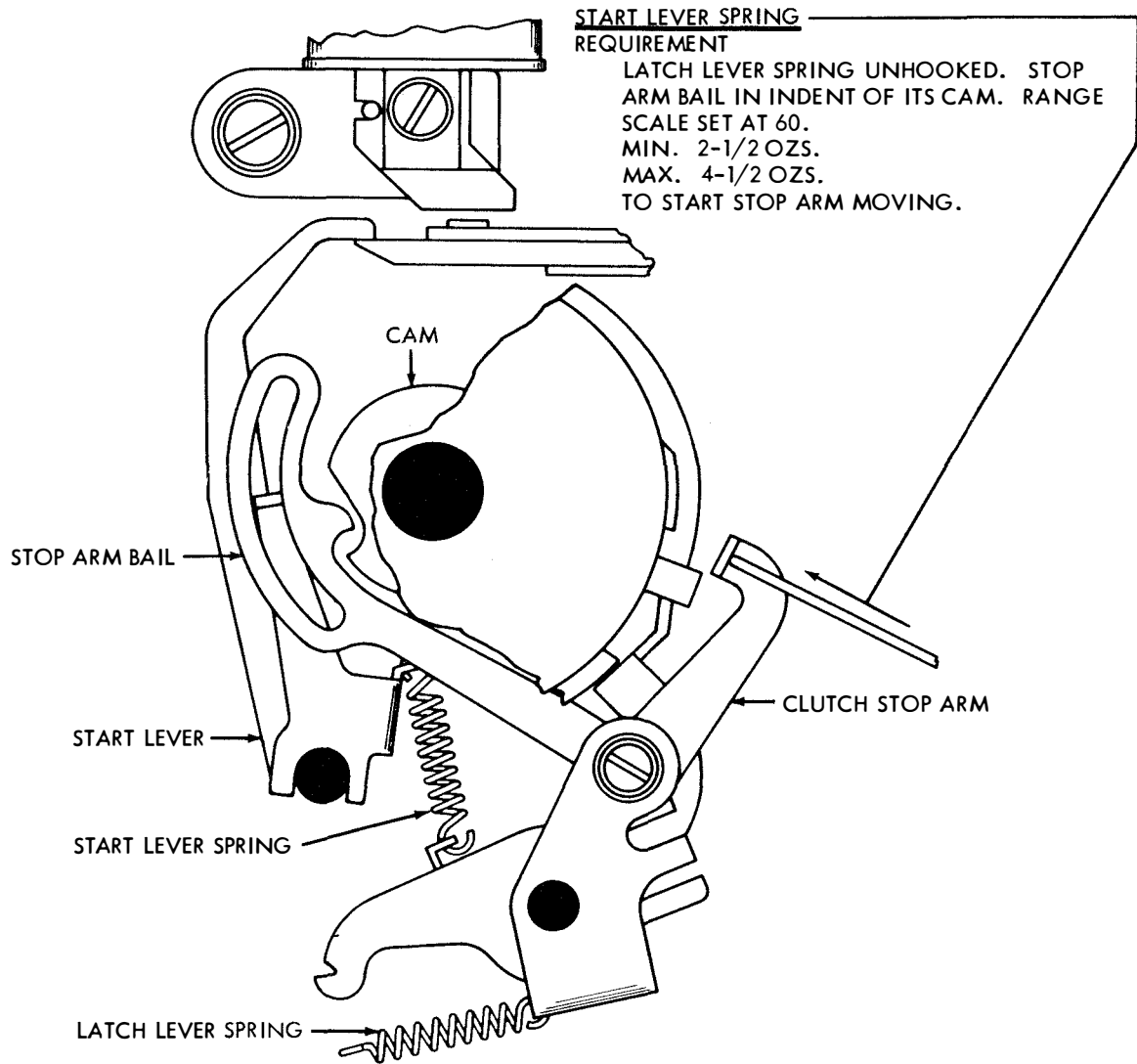

**SELECTOR RECEIVING MARGIN**

WHEN A SIGNAL DISTORTION TEST SET IS USED FOR DETERMINING THE RECEIVING MARGINS OF THE SELECTOR, AND WHERE THE CONDITION OF THE COMPONENTS IS EQUIVALENT TO THAT OF NEW EQUIPMENT, THE RANGE AND DISTORTION TOLERANCES BELOW SHOULD BE MET.

SELECTOR RECEIVING MARGIN MINIMUM REQUIREMENTS

CURRENT	SPEED IN WPM	POINTS RANGE WITH ZERO DISTORTION		PERCENTAGE OF MARKING AND SPACING BIAS TOLERATED		END DISTORTION TOLERATED WITH SCALE AT BIAS OPTIMUM SETTING	
		5 LEVEL	8 LEVEL	5 LEVEL	8 LEVEL	5 LEVEL	8 LEVEL
0.060 AMP (WINDINGS PARALLEL)	60	72	65	40	35	35	30
	100	72	65	40	35	35	30
0.020 AMP. (WINDINGS SERIES)	60	72	65	40	35	35	30

TO ADJUST: REFINE THE SELECTOR ARMATURE SPRING (FIGURE 3-7).

FIGURE 3-11

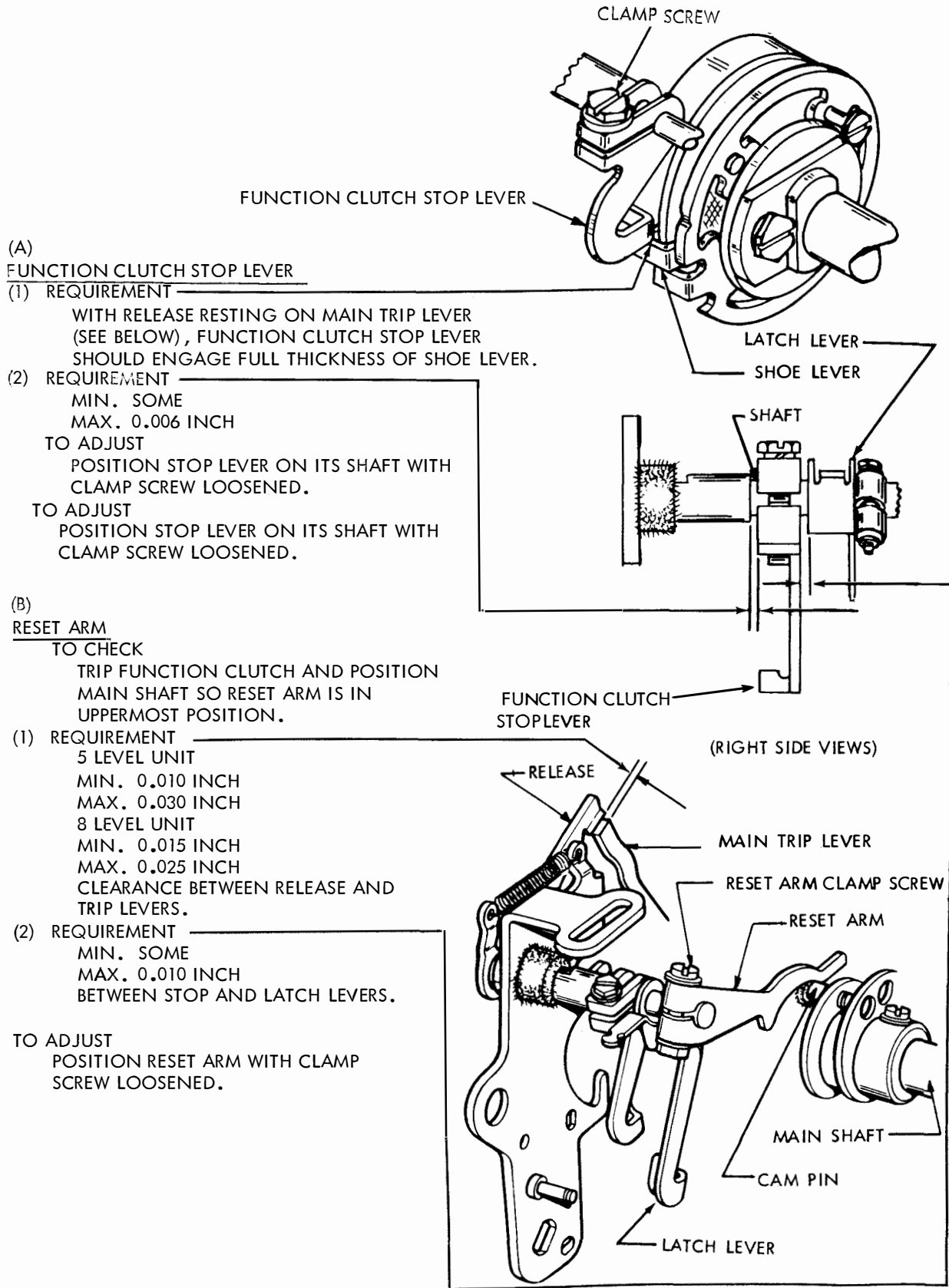

FIGURE 3-12

FOLLOWER LEVERTO CHECK

FOLLOWER LEVER ON HIGH PART OF CAM.

(1) REQUIREMENT

5 LEVEL UNITS

MIN. 0.010 INCH

MAX. 0.030 INCH

8 LEVEL UNITS

MIN. 0.005 INCH

MAX. 0.020 INCH

CLEARANCE BETWEEN MAIN TRIP LEVER AND DOWNSTOP BRACKET.

(2) REQUIREMENT

SOME CLEARANCE BETWEEN MAIN TRIP LEVER AND DOWNSTOP BRACKET.

TO ADJUST

BY MEANS OF PRY POINT, POSITION ADJUSTING ARM ON FOLLOWER LEVER WITH LOCK NUT LOOSENED.

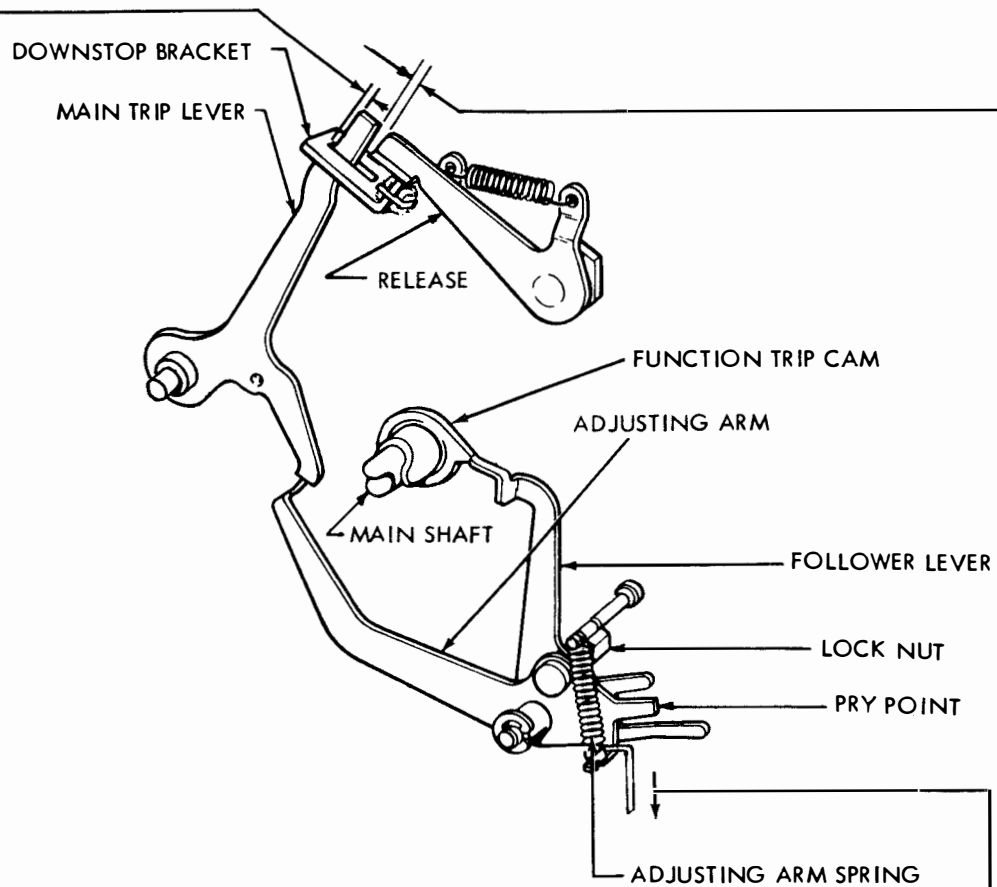
ADJUSTING ARM SPRINGREQUIREMENT

WITH FOLLOWER LEVER ON HIGH PART OF TRIP CAM, AND MAIN TRIP LEVER HELD AWAY FROM ADJUSTING ARM:

MIN. 2-1/2 OZS.

MAX. 4 OZS.

TO START ADJUSTING LEVER MOVING.

FIGURE 3-13

(A) FUNCTION CLUTCH RELEASE SPRING  
TO CHECK

TRIP FUNCTION CLUTCH. ROTATE MAIN  
SHAFT UNTIL RELEASE IS RESET ON MAIN  
TRIP LEVER.  
REQUIREMENT  
MIN. 5 OZS.  
MAX. 8 OZS.  
TO START RELEASE LEVER MOVING.

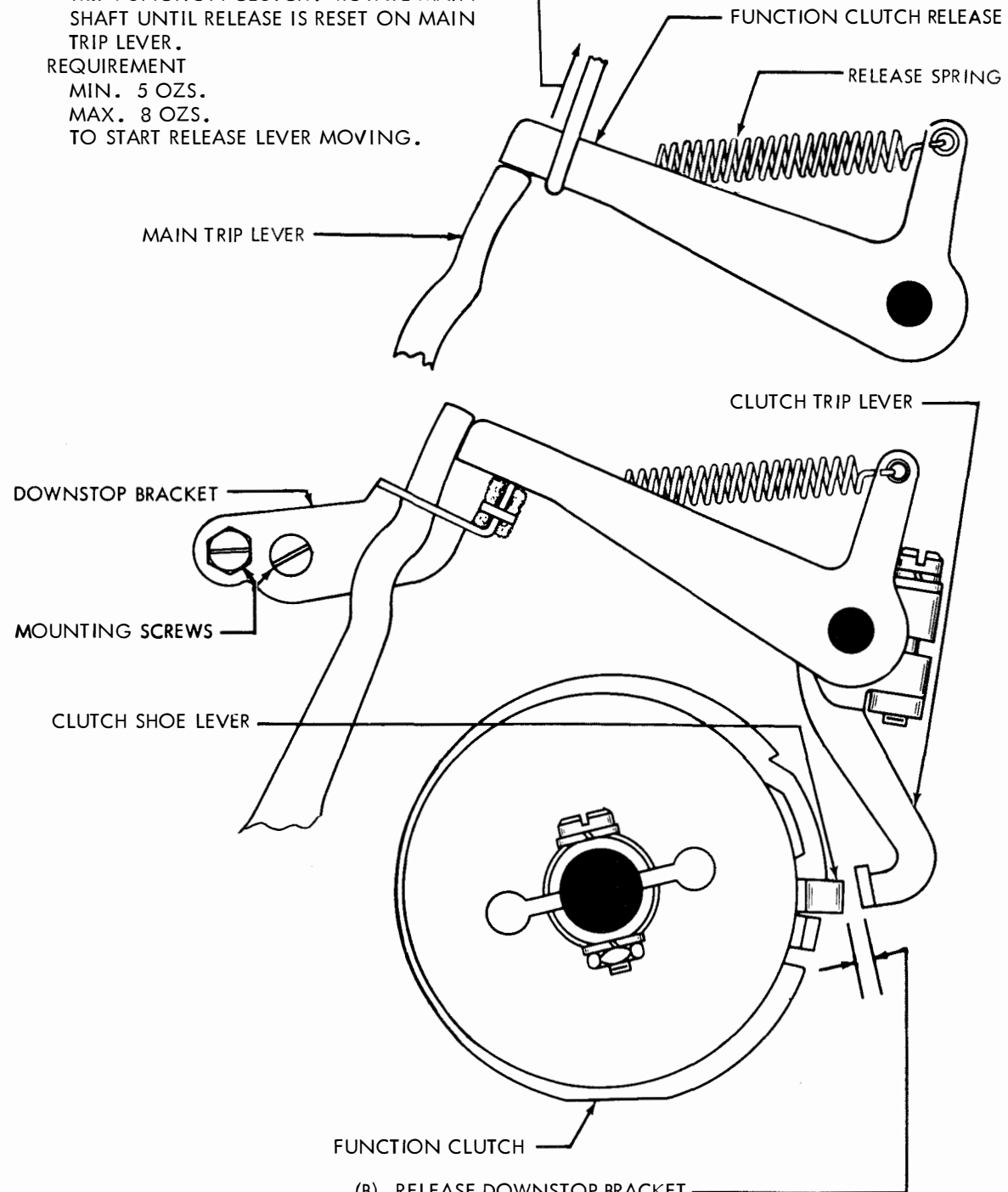

(B) RELEASE DOWNSTOP BRACKET  
REQUIREMENT

WITH FUNCTION CLUTCH TRIPPED:  
MIN. 0.002 INCH  
MAX. 0.045 INCH  
CLEARANCE BETWEEN TRIP LEVER AND CLUTCH SHOE LEVER  
AT POINT WHERE CLEARANCE IS LEAST.  
TO ADJUST  
POSITION DOWNSTOP BRACKET WITH MOUNTING SCREWS  
FRICTION TIGHT.

FIGURE 3-14

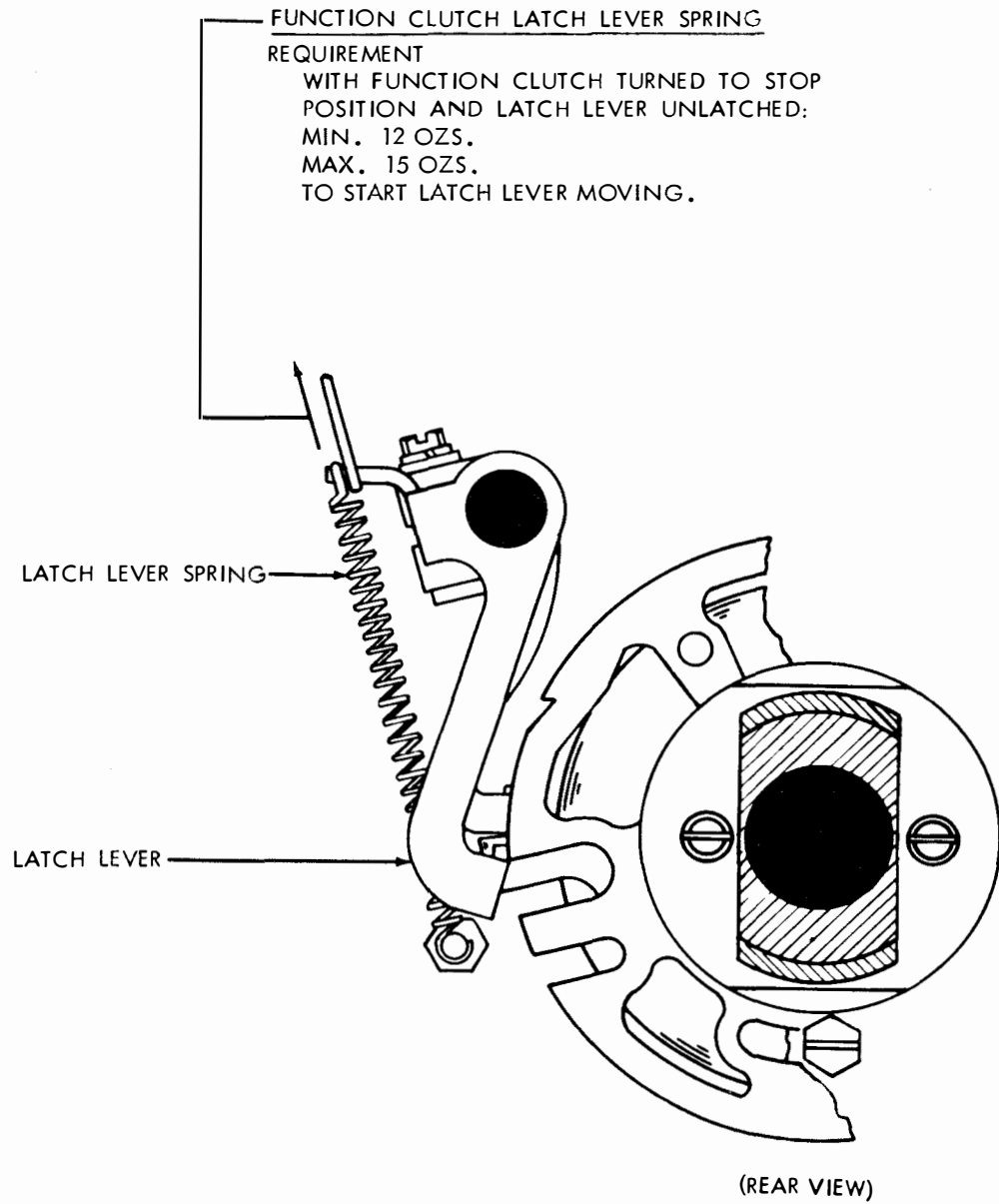

FIGURE 3-15

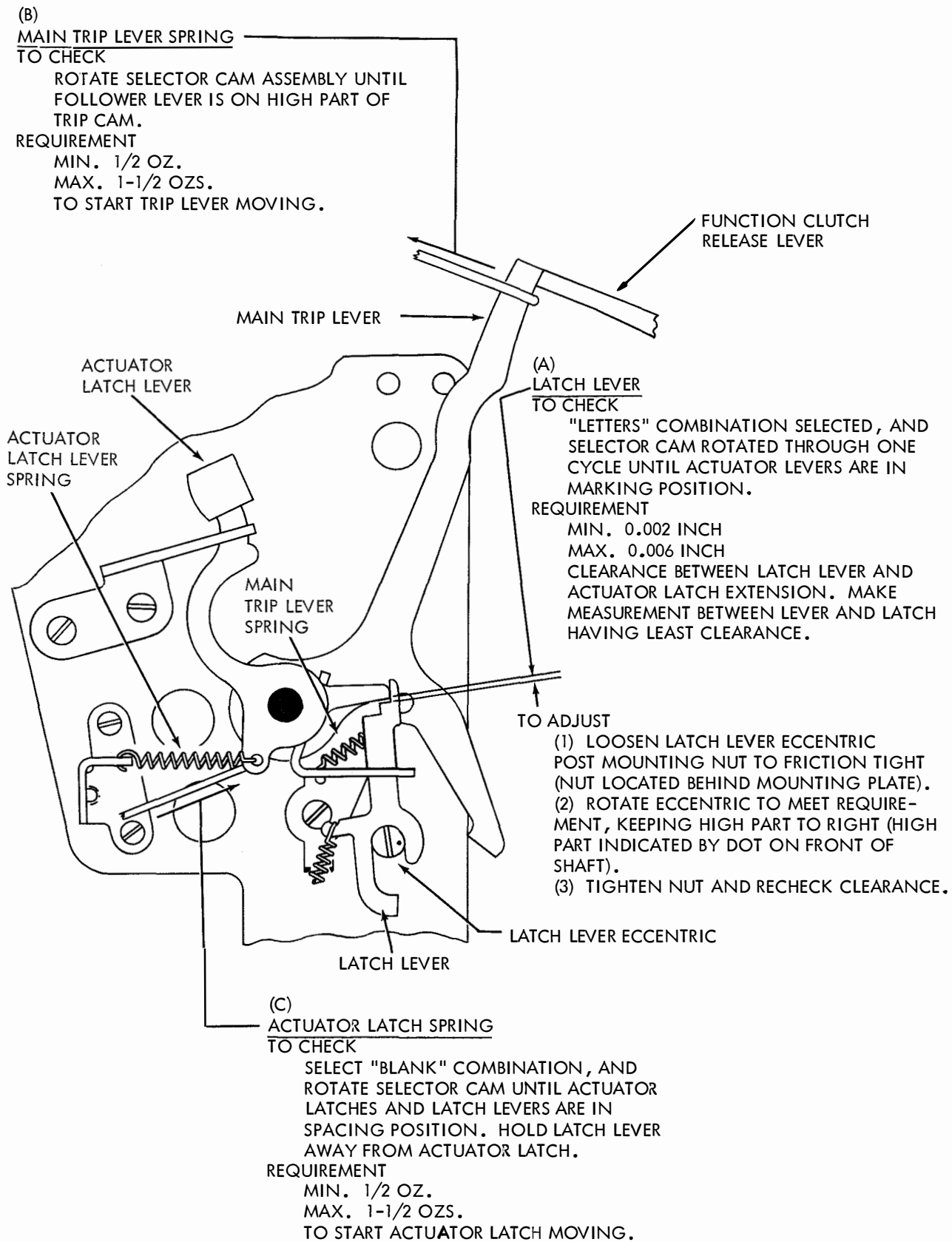

FIGURE 3-16

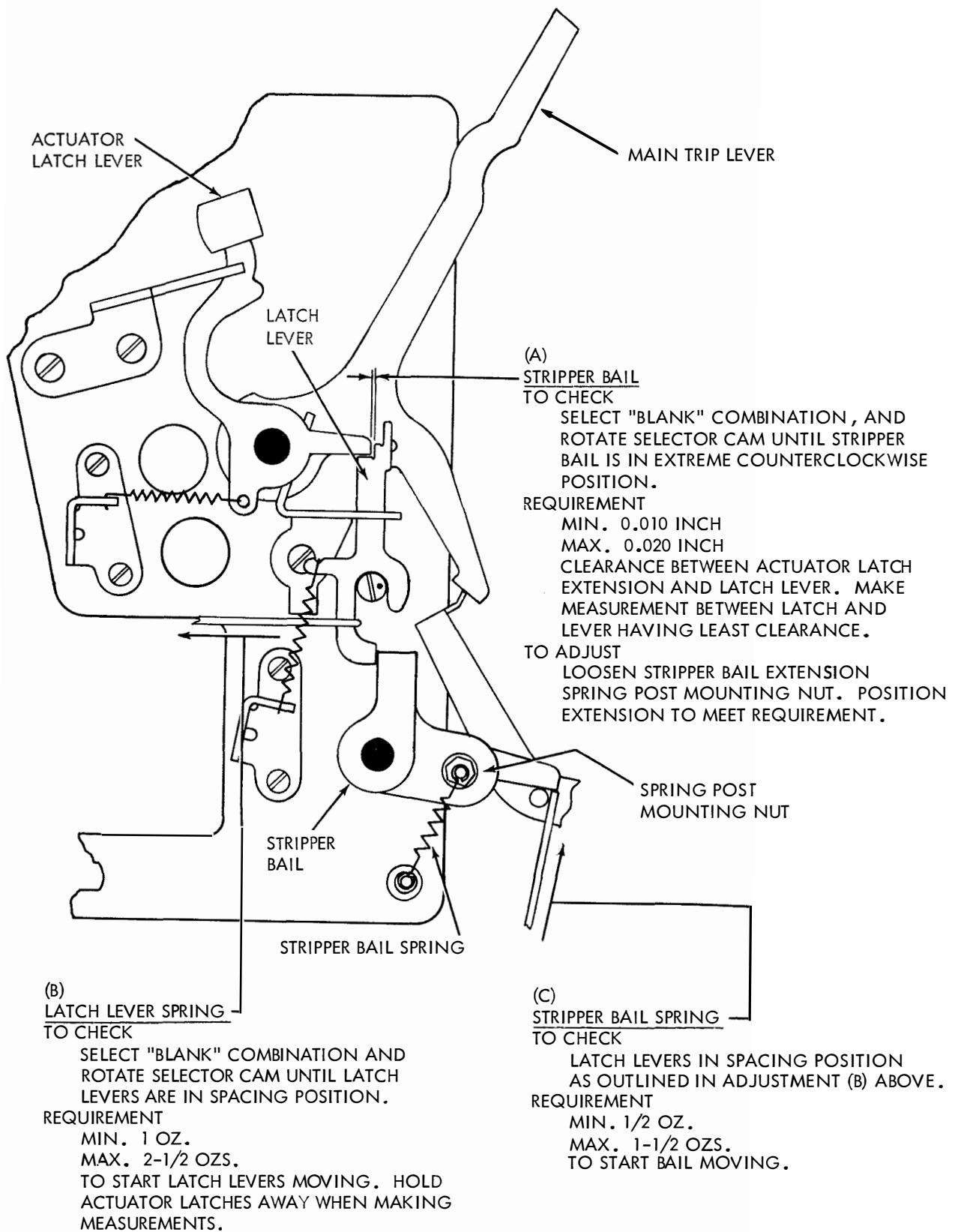
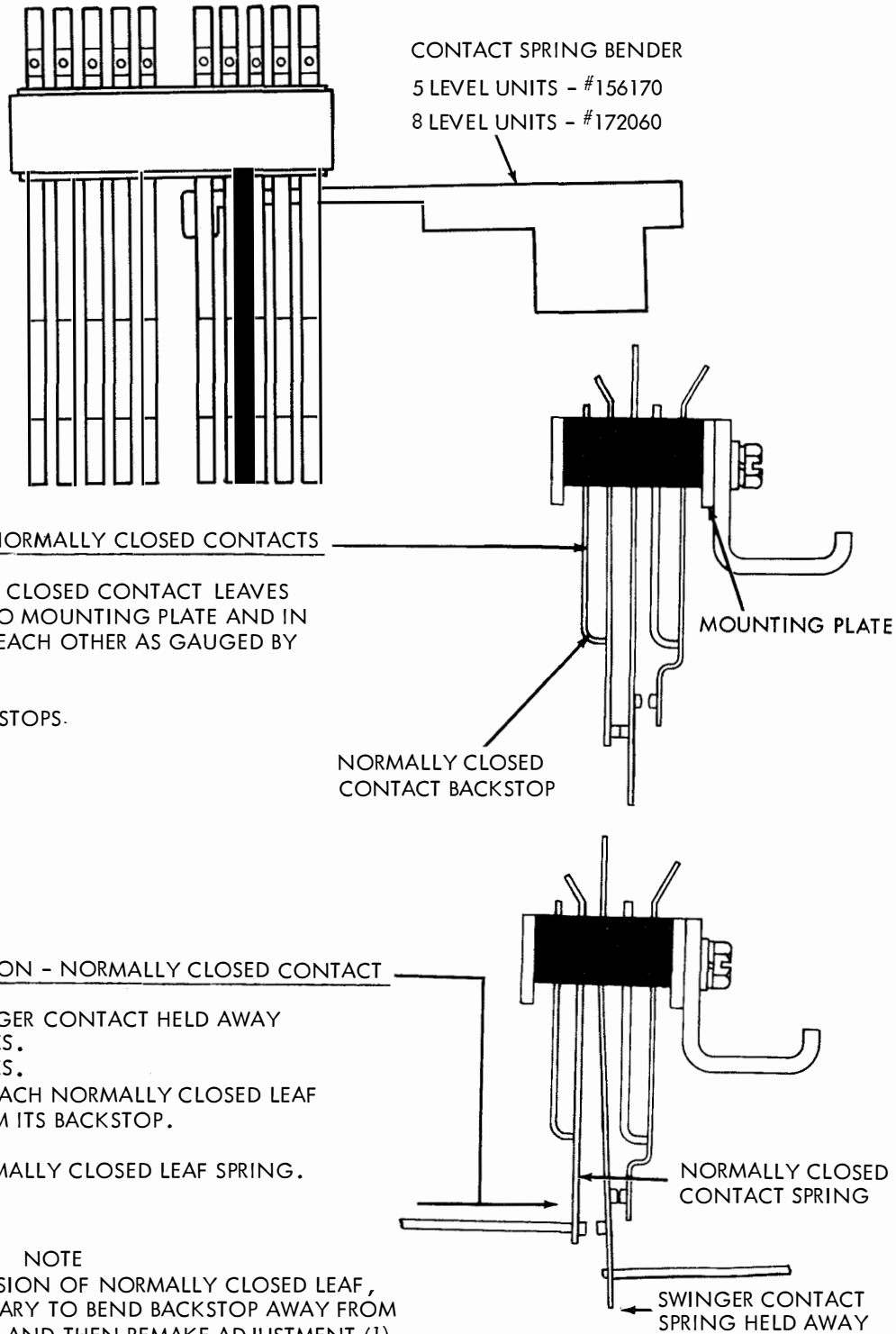

FIGURE 3-17

CODE READING CONTACT ASSEMBLY ADJUSTMENTS

NOTE

THE FOLLOWING FIVE (5) ADJUSTMENTS ARE TO BE MADE WITH THE CODE READING CONTACT ASSEMBLY REMOVED FROM THE UNIT. OBSERVE THAT THE CONTACTS ARE ARRANGED IN TWO GROUPS OF FIVE (5) CONTACTS EACH. WORK ON ONLY ONE GROUP AT A TIME. USE A CONTACT SPRING BENDER TO BEND THE CONTACTS. FOR EACH ADJUSTMENT, START WITH THE CONTACT PILE-UP FARTHEST FROM THE HANDLE OF THE BENDING TOOL TO AVOID DISTURBING COMPLETED ADJUSTMENTS.



- (1) BACKSTOP - NORMALLY CLOSED CONTACTS REQUIREMENT  
 NORMALLY CLOSED CONTACT LEAVES PARALLEL TO MOUNTING PLATE AND IN LINE WITH EACH OTHER AS GAUGED BY EYE.  
 TO ADJUST BEND BACKSTOPS.

- (2) SPRING TENSION - NORMALLY CLOSED CONTACT REQUIREMENT  
 WITH SWINGER CONTACT HELD AWAY  
 MIN. 2 OZS.  
 MAX. 6 OZS.  
 TO MOVE EACH NORMALLY CLOSED LEAF AWAY FROM ITS BACKSTOP.  
 TO ADJUST BEND NORMALLY CLOSED LEAF SPRING.

NOTE

TO INCREASE TENSION OF NORMALLY CLOSED LEAF, IT MAY BE NECESSARY TO BEND BACKSTOP AWAY FROM LEAF, BEND LEAF, AND THEN REMAKE ADJUSTMENT (1).

FIGURE 3-18



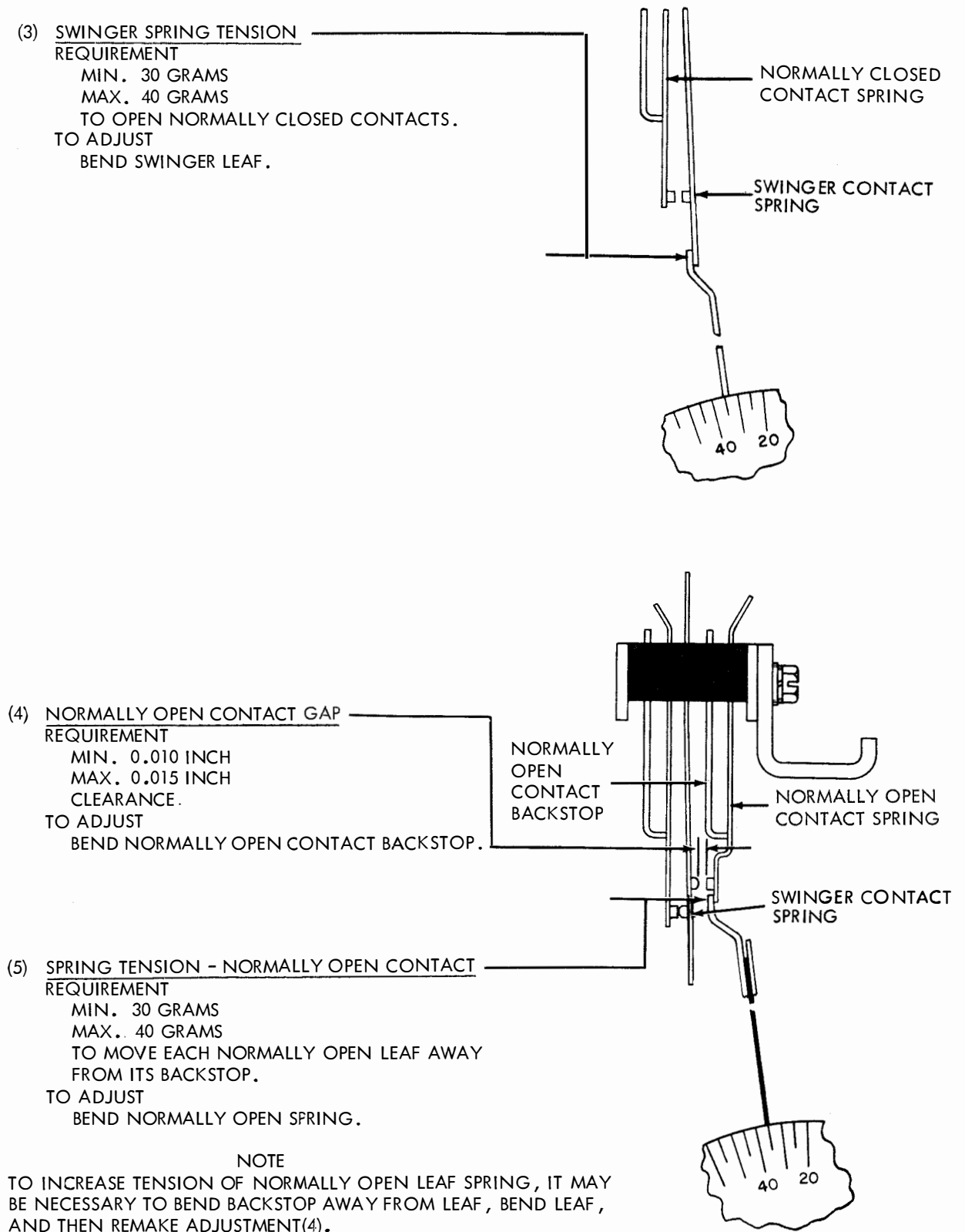
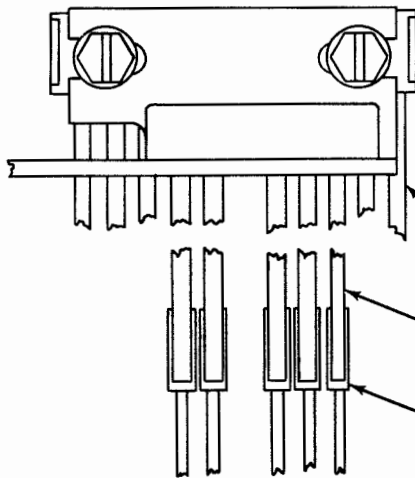

FIGURE 3-19

CODE READING CONTACT ASSEMBLY



(A) CODE READING CONTACT POSITION REQUIREMENT  
 CODE READING CONTACT SWINGERS CENTERED ON THEIR RESPECTIVE ACTUATOR LATCH INSULATOR PADS.  
 TO ADJUST POSITION CODE READING CONTACT PILE-UP WITH ITS MOUNTING SCREWS LOOSENED.

MOUNTING BRACKET  
 SWINGER  
 ACTUATOR LATCH INSULATOR

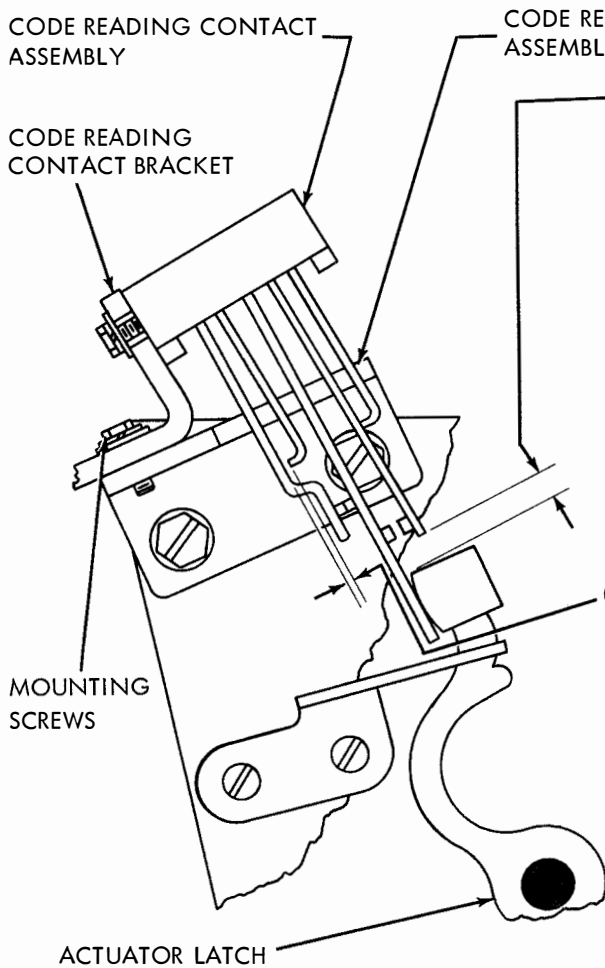

(B) CODE READING CONTACT SPRING CLEARANCE REQUIREMENT

MIN. 0.035 INCH  
 MAX. 0.070 INCH  
 CLEARANCE BETWEEN TOP OF ACTUATOR LATCH INSULATOR PAD AND TIP OF NORMALLY CLOSED (SPACING) CONTACT SPRING.

TO CHECK  
 OPERATE ACTUATOR LATCHES TO MARKING (LEFT) POSITION. MEASURE BETWEEN PAD AND SPRING TIP HAVING LEAST CLEARANCE.

TO ADJUST  
 POSITION CODE READING CONTACT ASSEMBLY MOUNTING BRACKET UP OR DOWN, WITH ITS MOUNTING SCREWS FRICTION TIGHT.

(C) CODE READING CONTACT BRACKET REQUIREMENT

MIN. 0.002 INCH  
 MAX. 0.008 INCH  
 CLEARANCE BETWEEN NORMALLY OPEN CODE READING CONTACT SPRING AND ITS ASSOCIATED BACKSTOP.

TO CHECK  
 SELECT "BLANK" COMBINATION. ROTATE MAIN SHAFT UNTIL SELECTOR AND FUNCTION CLUTCHES ARE DISENGAGED AND LATCHED. MANUALLY OPERATED ACTUATOR LATCHES TO MARKING (LEFT) POSITION. MAKE MEASUREMENT AT FOREMOST AND REARMOST CONTACTS.

TO ADJUST  
 POSITION CODE READING CONTACT MOUNTING BRACKET WITH ITS MOUNTING SCREWS FRICTION TIGHT.

FIGURE 3-20

## TIMING CONTACT ASSEMBLY ADJUSTMENTS

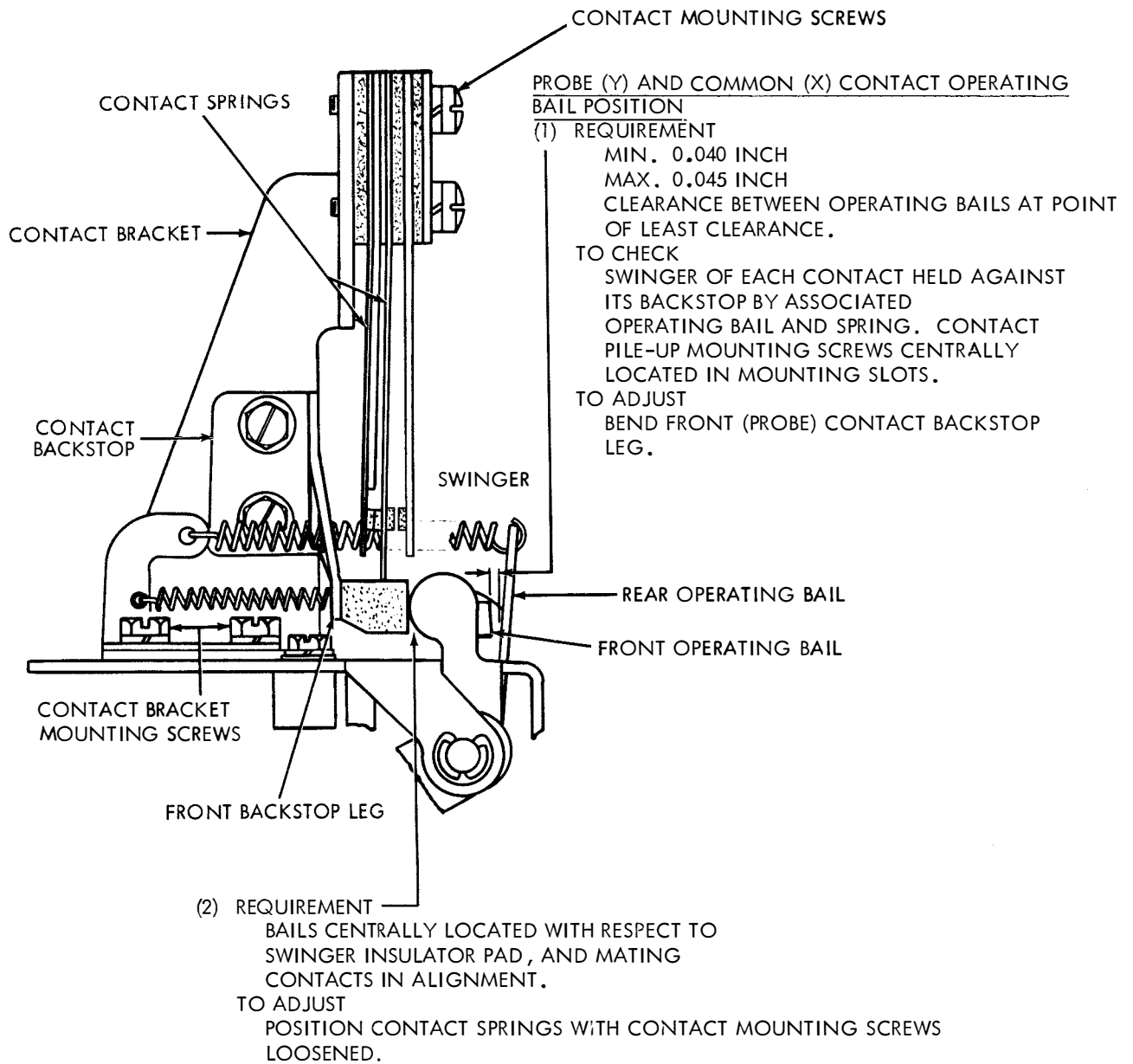
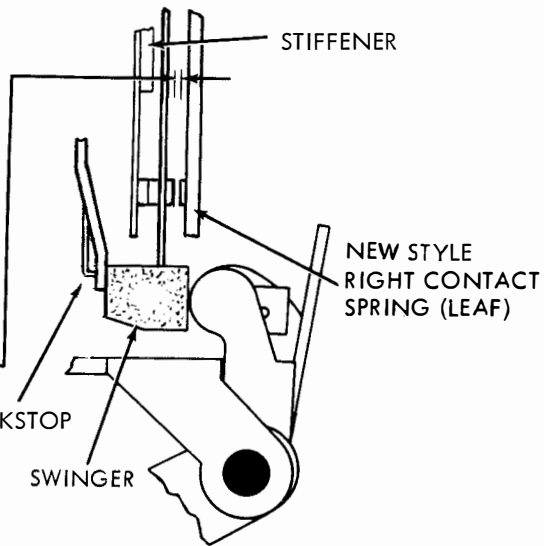
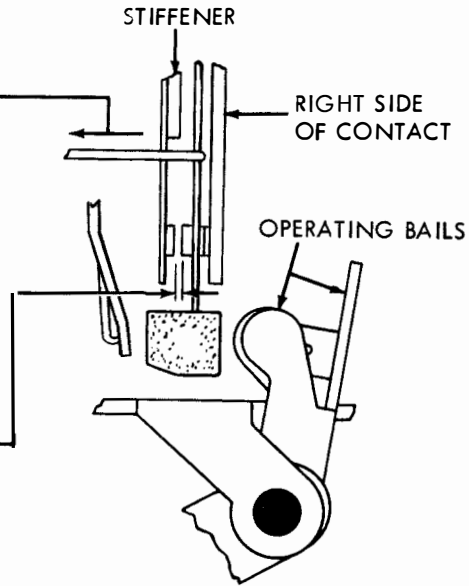

FIGURE 3-21

NOTE  
 MAKE THE FOLLOWING TIMING CONTACT ADJUSTMENTS  
 WITH THE CONTACT ASSEMBLIES REMOVED FROM THE UNIT.  
 THE ADJUSTMENTS APPLY TO BOTH THE PROBE (Y) AND  
 COMMON (X) CONTACT ASSEMBLIES.



- (A) NORMALLY CLOSED CONTACT GAP  
 REQUIREMENT  
 MIN. 0.020 INCH  
 MAX. 0.025 INCH  
 GAP BETWEEN CONTACTS WHEN SWINGER  
 IS HELD AGAINST BACKSTOP.  
 TO ADJUST  
 BEND THICK (RIGHT) SPRING LEAF.



- (B) NORMALLY CLOSED CONTACT PRESSURE  
 REQUIREMENT  
 MIN. 4 1/2 OZS.  
 MAX. 5 1/2 OZS.  
 TO OPEN NORMALLY CLOSED CONTACTS  
 TO CHECK  
 HOLD OPERATING BAIL AWAY FROM SWINGER.  
 TO ADJUST  
 BEND SWINGER. RECHECK ADJUSTMENT (A).  
 AND REFINE IF NECESSARY.

- (C) NORMALLY OPEN CONTACT GAP  
 REQUIREMENT  
 MIN. 0.020 INCH  
 MAX. 0.025 INCH  
 GAP BETWEEN CONTACTS WHEN SWINGER  
 IS HELD AGAINST BACKSTOP.  
 TO ADJUST  
 BEND STIFFENER.

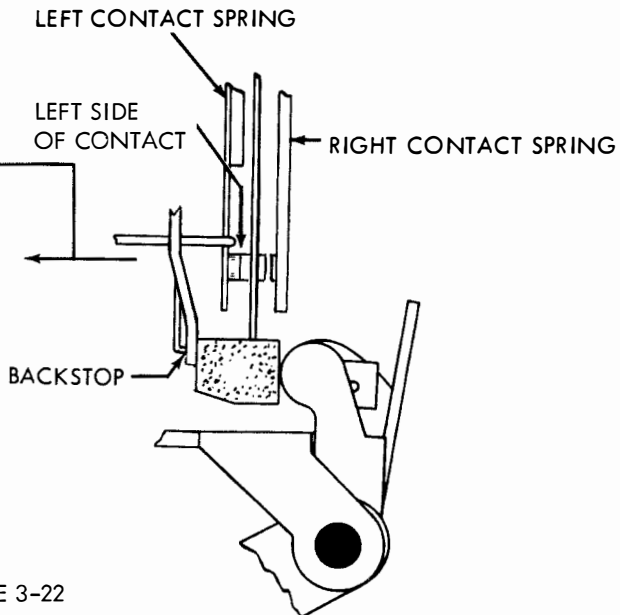

- (D) NORMALLY OPEN CONTACT PRESSURE  
 TO CHECK  
 SWINGER HELD AGAINST BACKSTOP BY  
 ITS OPERATING BAIL.  
 REQUIREMENT  
 MIN. 4 1/2 OZS.  
 MAX. 5 1/2 OZS.  
 TO OPEN LEFT SIDE OF CONTACT.  
 TO ADJUST  
 BEND LEFT CONTACT SPRING. RECHECK  
 ADJUSTMENTS (A) AND (C), AND REFINE  
 IF NECESSARY.

FIGURE 3-22

NOTE  
REPLACE TIMING CONTACT ASSEMBLY ON UNIT.

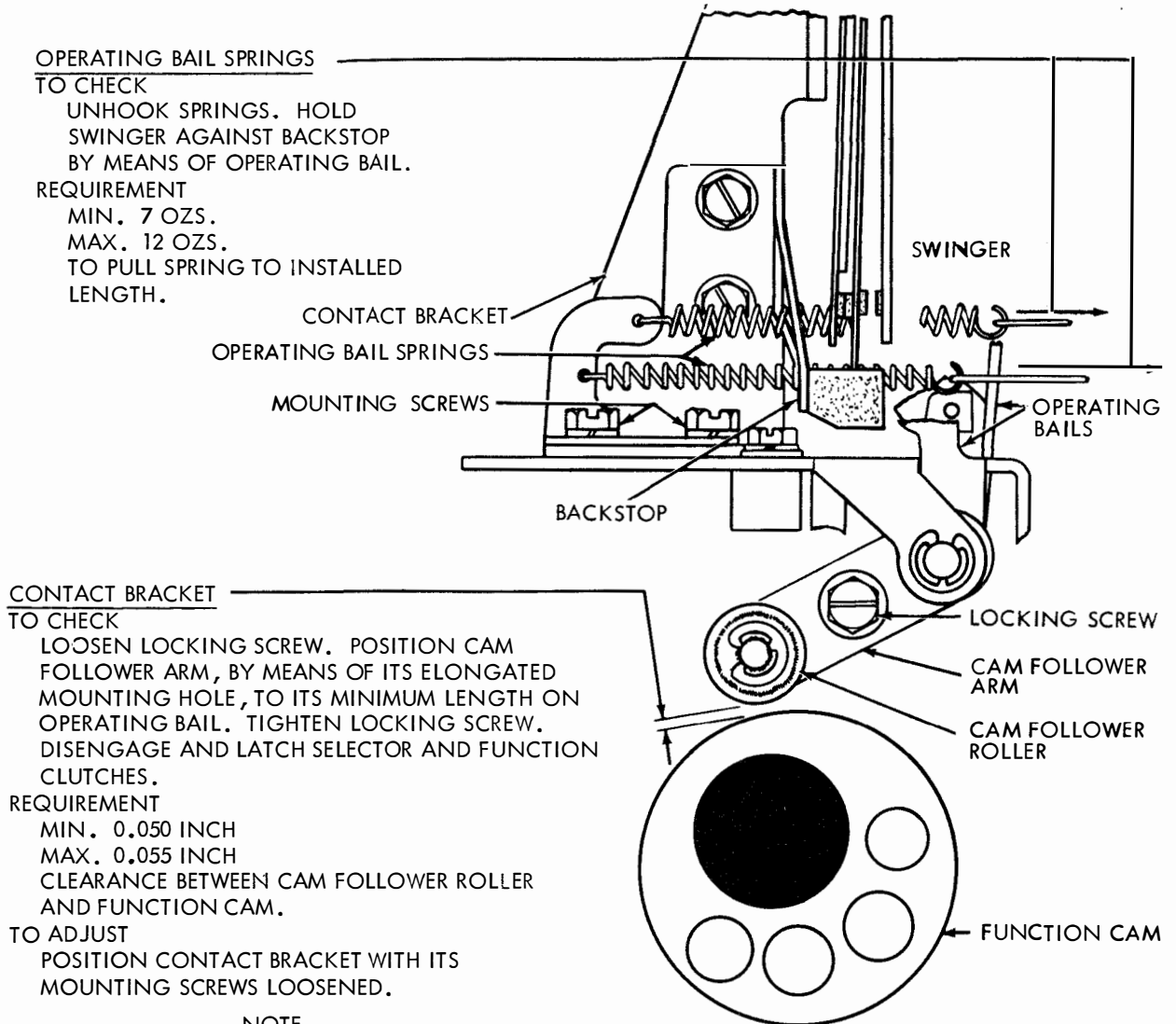

NOTE  
RECHECK PROBE (Y) AND COMMON (X) CONTACT OPERATING BAIL POSITION ADJUSTMENT  
(SEE FIGURE 3-21). IF BAIL CLEARANCE IS NOT MET, REFINE SWITCH MOUNTING BRACKET POSITION.

FIGURE 3-23

b. BASE & MOTOR UNIT

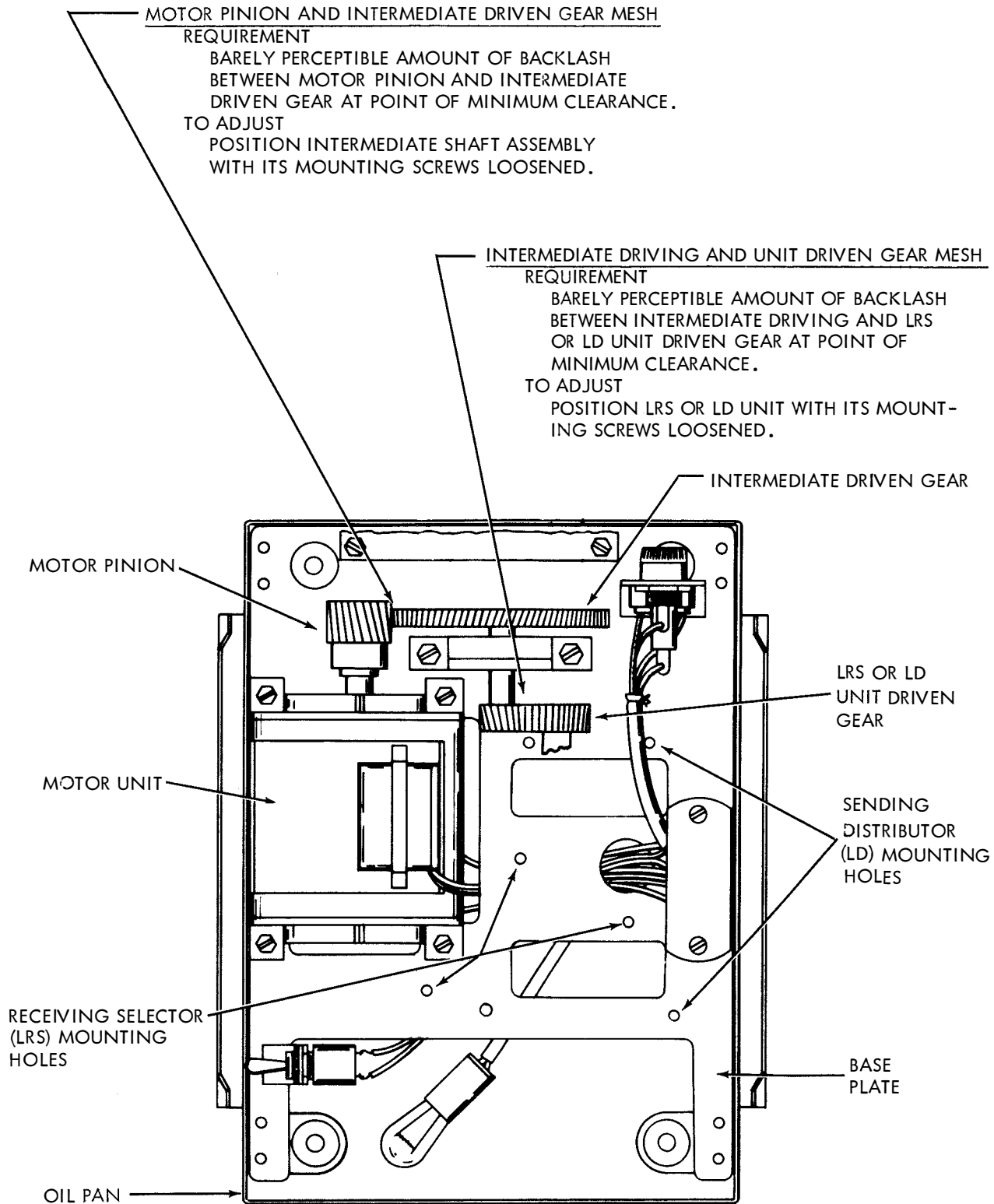

FIGURE 3-24

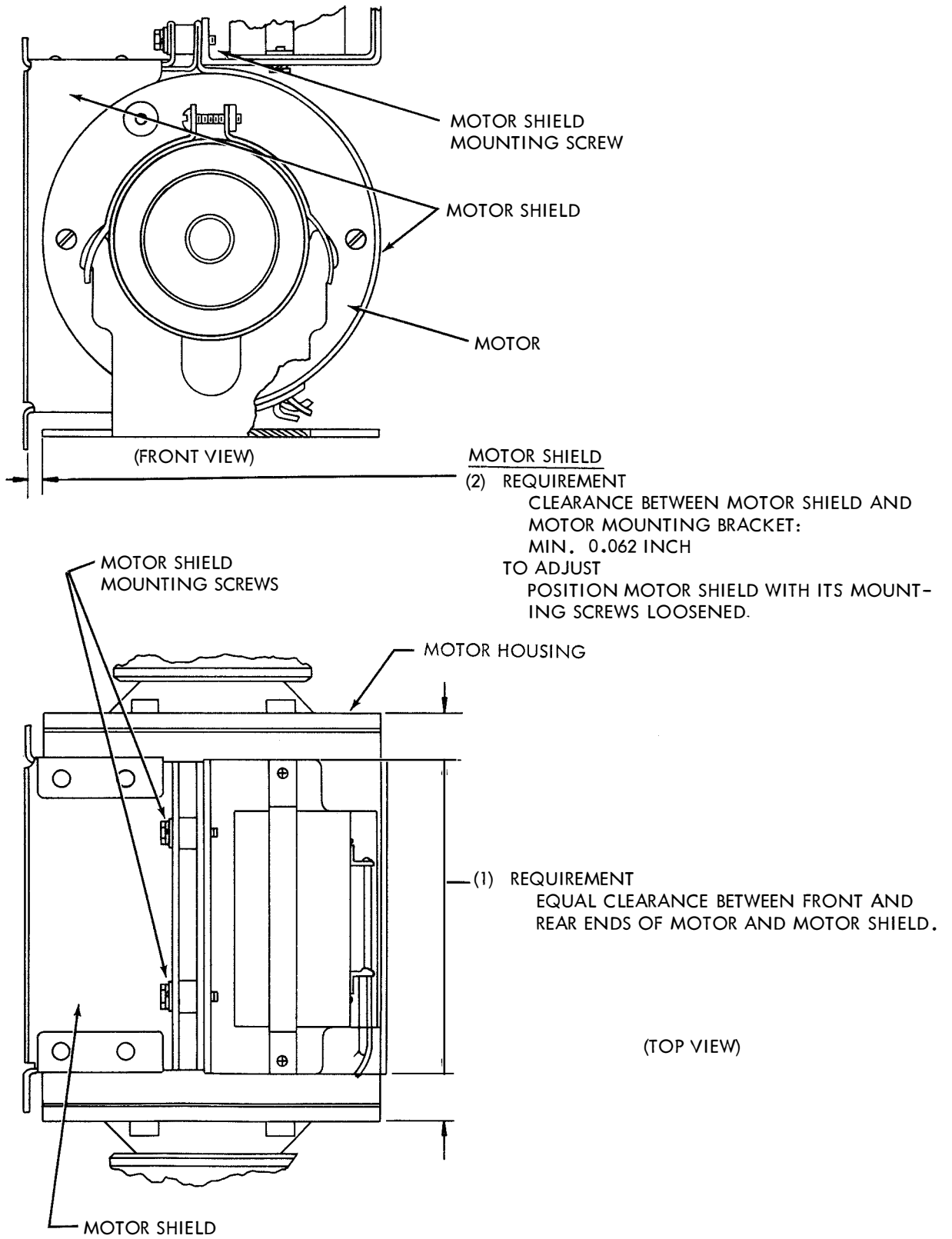

FIGURE 3-25

## 3-6. CODE READING AND TIMING CONTACT STROBING PROCEDURE

## a. Introduction

The following adjustment procedure outlines pulse length requirements for the code reading and timing contacts of the (LRS) Receiving Selector Set. In all cases, both the test set and the unit under test must be operating at the same speed for proper strobing. All pulse length requirements are made with respect to a 7.42 unit code test set scale. To strobe the code reading and timing contacts, a Signal Distortion Test Set (DXD) is used. For operation of this set, refer to Teletype Bulletin 181B.

## b. General Testing Information

- (1) Preliminary Preparation - Perform the following tests after completing the adjustment of the code reading and timing contacts as outlined in paragraph 3-5.a. For all strobing tests, the DXD and LRS should be operating at 600 OPM.
- (2) DXD "zero" - In order to perform the following tests, observation of a neon trace on the scale of the DXD will have to be made. Since the trace has a tendency to "jump" (i.e., the trace will not remain steady, but may vary as much as 10 scale divisions), the following steps should be taken to "zero" the DXD:
  - (a) While receiving alternate "LETTERS - BLANK" (all marking - all spacing) code combinations, connect the neon trace lamp to the #1 normally open code reading contact. Observe, and note, the point at which the trace begins. This point will "jump" - as mentioned above - and only the minimum reading should be noted.
  - (b) Repeat the above procedure for all the contacts, and choose the trace which starts latest. Set the "START" zero mark of the DXD scale to this point.
  - (c) Record the earliest end of the trace for future adjustment reference.

## c. Code Reading Contacts - Strobing Procedure

- (1) Zero the DXD test set as outlined in paragraph 3-6.b. (2).
- (2) Connect the neon trace lamp to the 5th (5 level units) or 8th (eight level units) normally open contact of the contact assembly.
  - (a) Requirements (See Figure 1)

The marking code reading contact trace - including breaks - shall have a minimum signal length of 700 divisions in the "LETTERS" (all marking) position. All bounce must end within 20 divisions of the earliest start or latest end of the contact traces (as determined during the DXD "zero" procedure - paragraph 3-6.b. (2)).

## To Check

Receiving Selector Set operating, and receiving alternate "LETTERS - BLANK" (all marking - and spacing) code combinations.

## To Adjust

Refine code reading contact assembly adjustments and spring tensions.

(b) Requirement

Normally closed contact opens before normally open contact closes (i.e., contacts should break before make).

## To Check

Turn unit off. With code reading contact swinger in spacing position, manually operate swinger to marking position. Check all contacts.





## To Adjust

Refine code reading contact assembly adjustments and spring tensions. Recheck requirements (a) and (b) if any refinements are made.

## d. Timing Contacts - Strobing Procedure

- (1) Zero the DXD test set as outlined in paragraph 3-6.b. (2).
- (2) With the Receiving Selector Set in idle position, connect the neon trace lamp to the normally open contact of the Common (X) contact pile-up.

(a) Requirements (See Figure 2)

The earliest starting trace shall begin no sooner than 50 divisions after the DXD zero mark, and the latest ending trace shall end no later than 50 divisions from the earliest end of the code reading contact traces (as determined during the DXD zero procedure - paragraph 3-6.b. (2)). The minimum trace length shall be 225 divisions. All bounce must end within 5 divisions of the earliest start and latest end of a trace.

## To Check

Receiving Selector Set operating and receiving "LETTERS" (all marking) code combinations.

## To Adjust

Refine timing contact adjustments and spring tensions.

(b) Requirements (See Figure 3)

Connect neon trace to both contacts of the Probe (y) contact pile-up. There shall be at least a 10 division break in the trace indicating the break before make contact. There shall be at least 325 to 420 division between the earliest starts of the normally open and normally closed contacts. All bounce must end within 5 divisions of the earliest start and latest end of a trace.

## To Adjust

Refine timing contact adjustments and spring tensions. Recheck requirements (a) and (b) if any refinements are made.

## SECTION 4

## DISASSEMBLY

## 4-1. INTRODUCTION

a. The purpose of this section is to aid maintenance personnel in the disassembly of the (LRS) Receiving Selector Set. The procedure, as outlined, breaks the Set down into its major subassemblies only. Further disassembly procedures are not described, but may be undertaken if necessary. Refer to Teletype Parts Bulletin 1185B for detailed exploded illustrations of the parts referred to in the text.

b. The disassembly instructions are arranged in a sequence which should be followed only when a complete disassembly of the Set is required. The removal of a specific subassembly (for replacement or repair purposes) may not require the complete disassembly of the Set but will, however, normally require removal of associated subassemblies in the same area.

## 4-2. GENERAL DISASSEMBLY INSTRUCTIONS

a. During the disassembly of a mechanism, take careful note of the position and order of removed parts to facilitate reassembly. Retaining rings are made of spring steel and have a tendency to release suddenly. Loss of these rings can be minimized as follows: Hold the retaining ring to prevent it from rotating. Place a screwdriver blade into one of the ring's slots. Rotate the screwdriver in a direction to increase the diameter of the retaining ring.

b. When unsoldering leads from switch and connector terminals, the thermoplastic tubing over the leads might be damaged from the heat. Replace any damaged tubing. During the resoldering operation, avoid using an excessive amount of solder. Be especially careful to prevent solder from falling onto and becoming wedged between moving parts and electrical contact springs.

c. After all removed parts have been replaced, and any necessary adjustments made, the Set should be checked for proper operation before applying power to it. With the use of an armature spring clip (see Bulletin 1185B) to hold the selector armature in the attracted position, manually rotate the main shaft until the clutches latch. Operate the selector armature to allow unlatching of the clutches, and manually select various code combinations while checking operation of the set.

## 4-3. COVER

The LRS cover is removed by simply lift-

ing it up from the base. Lift it straight up, making certain it clears the selector mechanism before moving it in a lateral direction. To replace the cover, reverse the removal procedure.

## 4-4. RECEIVING SELECTOR (LRS)

a. Removal from Base - Disconnect the 36-point female connector from the connector brackets at the rear of the base. Remove the three mounting screws, lock washers, and flat washers which secure the Receiving Selector to the base plate. Remove the LRS from the base while guiding the cable assembly forward and up through the base plate cutout. To remount the LRS, refer to paragraph 2-3.e.

## b. Selecting Mechanism Removal

(1) Remove the screw, lock washer, and nut from the selector clutch drum. Hold the push lever reset bail in its raised position, and the stop arm and marking lock lever to the left (see NOTE). Grasp the cam-clutch by the cam disk (not by the drum) and pull forward while rotating the cam-clutch slowly. The cam-clutch should come off easily; it should not be forced.

## NOTE

To hold the push lever reset bail in its raised position, place the blade of a screwdriver under the forward extension of the reset bail. Apply pressure on the bail to push it toward the rear, and simultaneously lift upward on the extension with the screwdriver. The reset bail arm will engage a step in the push lever guide bracket, and hold the push levers in a raised position. To hold the marking lock lever and stop arm to the left, push the lock lever to the left until the left hole in its extension is on the left side of the guide bracket. Insert a pin (or other device) into this hole and release the lever. The pin will stop the marking lock lever from returning to the right.

(2) Unhook the spring on the function latch lever. Remove the spring post by removing its nut and lock washer, (located below the forward main shaft bearing on the function cam-clutch side of the frame) which passes through the frame and selector mounting plate into the selector lever guide. Remove the oil wick, screw, lock washer, and wick holder. Remove the selecting mechanism.

(3) To replace the selecting mechanism, reverse the above procedure.

## c. Main Shaft Removal

(1) Remove the selector cam-clutch (refer to paragraph 4-4.b.(1)).

(2) Remove the spring from the function clutch latch lever. Remove the retaining ring, spring washer and flat washers from the forward end of the main shaft.

(3) Remove the screw and lock washer from the function clutch drum. Remove the screw and lock washer from the collar. Remove the screw and lock washer which secures the rear bearing clamp.

(4) Pull the main shaft out towards the rear, removing the function cam-clutch and collar in the process.

## CAUTION

Note the location of the main shaft needle roller bearings, as shown in Bulletin 1185B. Move the main shaft toward the rear of the unit a small amount at a time. Exercise care not to drop or contaminate the 20 needle bearing rollers in each race. A spring may be stretched around the shaft and rollers, and its ends hooked together. The spring, in conjunction with the lubricant on the bearings, will hold the bearings in place.

(5) To replace the main shaft assembly, reverse the disassembly procedure. Make sure the rollers are clean, and lubricate them

as specified in Section 5.

## NOTE

When the main shaft is inserted into the cam-clutch assemblies, hold the latter firmly so that the drum is not pushed off the clutch. Compress the drum and cam disk together so that the holes in the drum and the clutch bearings are aligned.

## d. Main Plate Assembly Removal

(1) Place the actuator latch levers in the spacing position. Remove the spring which holds the latch lever reset bail biased against the trip lever. Remove the spring post and screw, at the bottom of the main plate, which secure the plate to the frame. Remove the oil wick, screw, lock washer, and wick holder. Remove the main plate assembly.

(2) To replace the main plate assembly, reverse the above procedure.

## 4-5. MOTOR UNIT

a. Disconnect the wiring at the 4-point terminal.

b. Remove the four screws and lock washers which secure the motor to the base plate. Remove the motor unit.

c. To remount the motor unit, refer to paragraph 2-3.d.

SECTION 5  
LUBRICATION

5-1. INTRODUCTION

This section provides lubrication instructions for the Teletype Model 28 (LRS) Receiving Selector Set. It is very important that thorough lubrication of the Set be performed at the intervals specified and with the lubricants recommended. Be sure to lubricate the equipment before its initial service, or prior to its storage.

CAUTION

The Receiving Selector is shipped with the selector cam oil reservoir empty. Fill the reservoir before placing the unit into operation. Refer to lubrication instructions on page 5-3.

5-2. GENERAL LUBRICATION INFORMATION

a. The specific points to receive lubrication are indicated by line drawings and descriptive text. These line drawings are keyed to photographs which show the general area referred to by the line drawing. The symbols in the text indicate the following directions:

- O Apply one drop of oil.
- O2 Apply two drops of oil.
- O3 Apply three drops of oil, etc.
- G Apply thin coat of grease.
- SAT Saturate with oil.

Use only Teletype KS7470 oil and KS7471 grease at the specified lubrication points.

b. The equipment should be thoroughly lubricated, but over-lubrication, which might allow oil to drip or grease to be thrown on other parts, should be avoided. Exercise special care to prevent any lubricant from getting between armature and pole faces. Keep all electrical

contacts free from oil or grease.

c. The following general instructions supplement the specific lubrication points illustrated in this section.

- (1) Apply one drop of oil to all spring hooks.
- (2) Apply a light film of oil to all cam surfaces.
- (3) Apply a coat of grease to all gears.
- (4) Saturate all felt washers, oilers, etc.
- (5) Apply oil to all pivot points.
- (6) Apply oil to all sliding surfaces.

d. After a few weeks of service, re-lubricate the Set to make certain that all specified points have received lubricant. Thereafter, adhere to the following schedule unless otherwise specified:

<u>OPERATING SPEED</u>	<u>LUBRICATION INTERVAL</u>
60 WPM	3000 hours or 1 year*
75 WPM	2400 hours or 9 months*
100 WPM	1500 hours or 6 months*

\*Whichever occurs first.

5-3 LUBRICATION

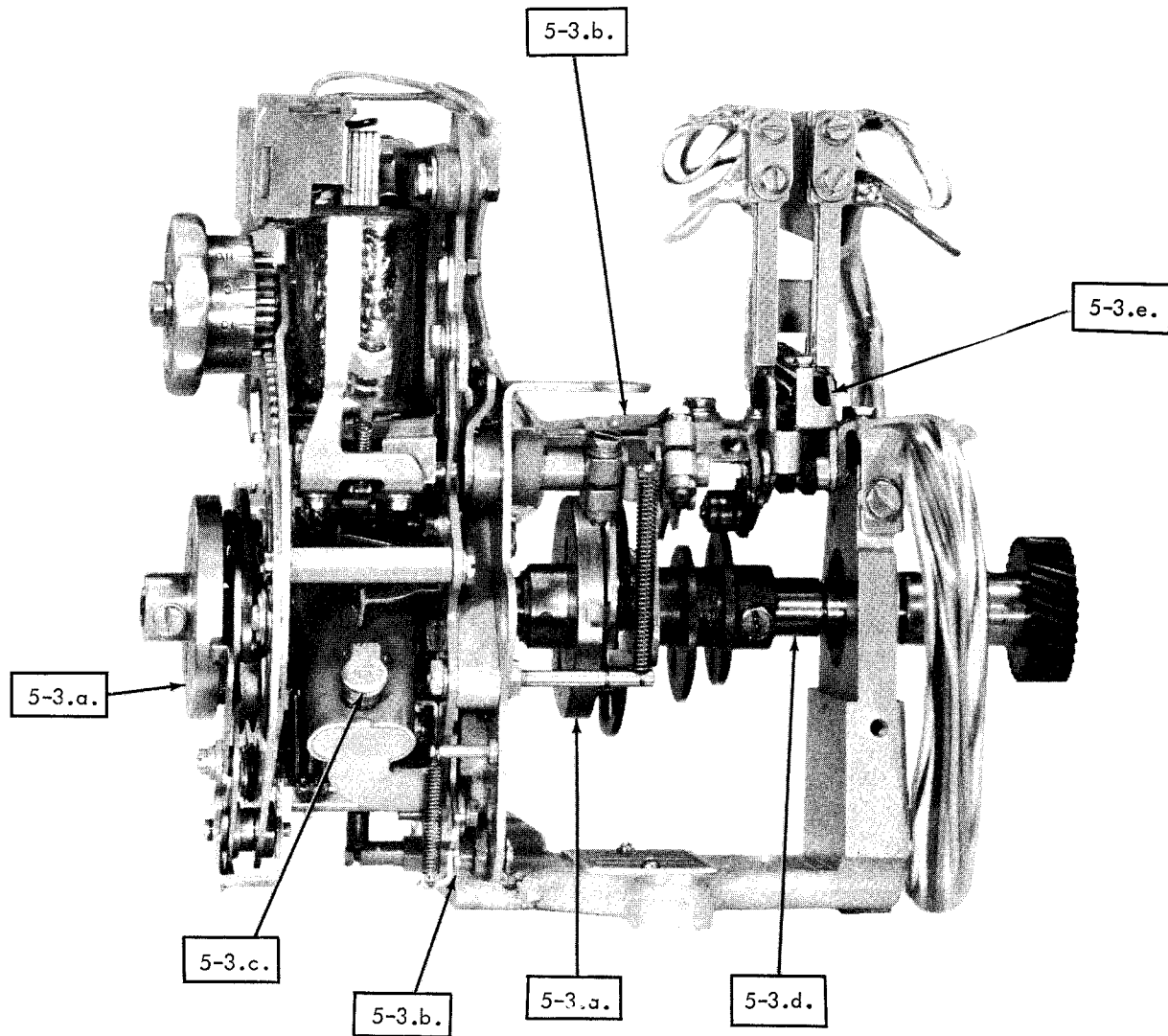

a. FUNCTION AND SELECTOR CLUTCH

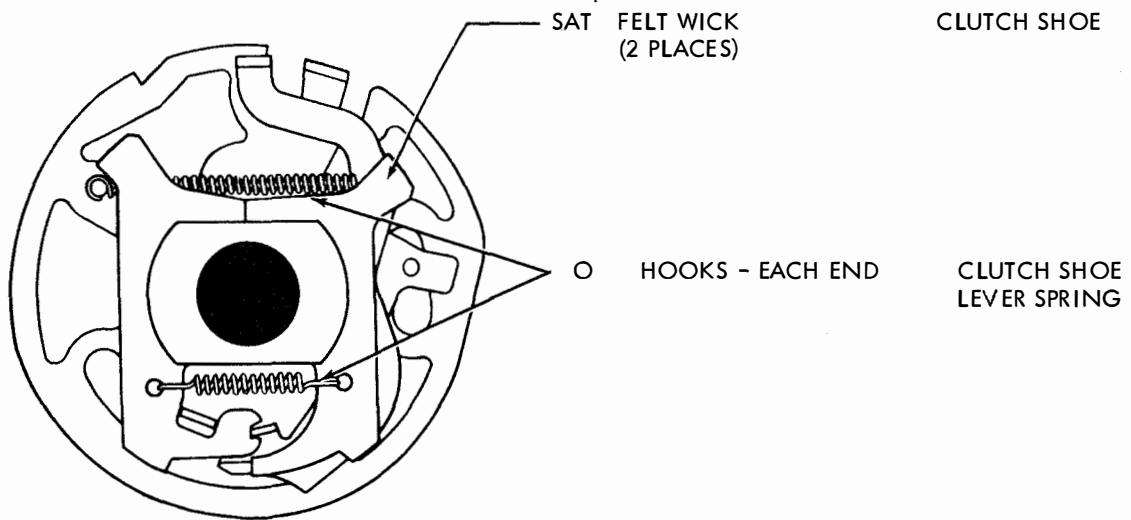

b. FUNCTION CAM AND CLUTCH TRIP MECHANISM

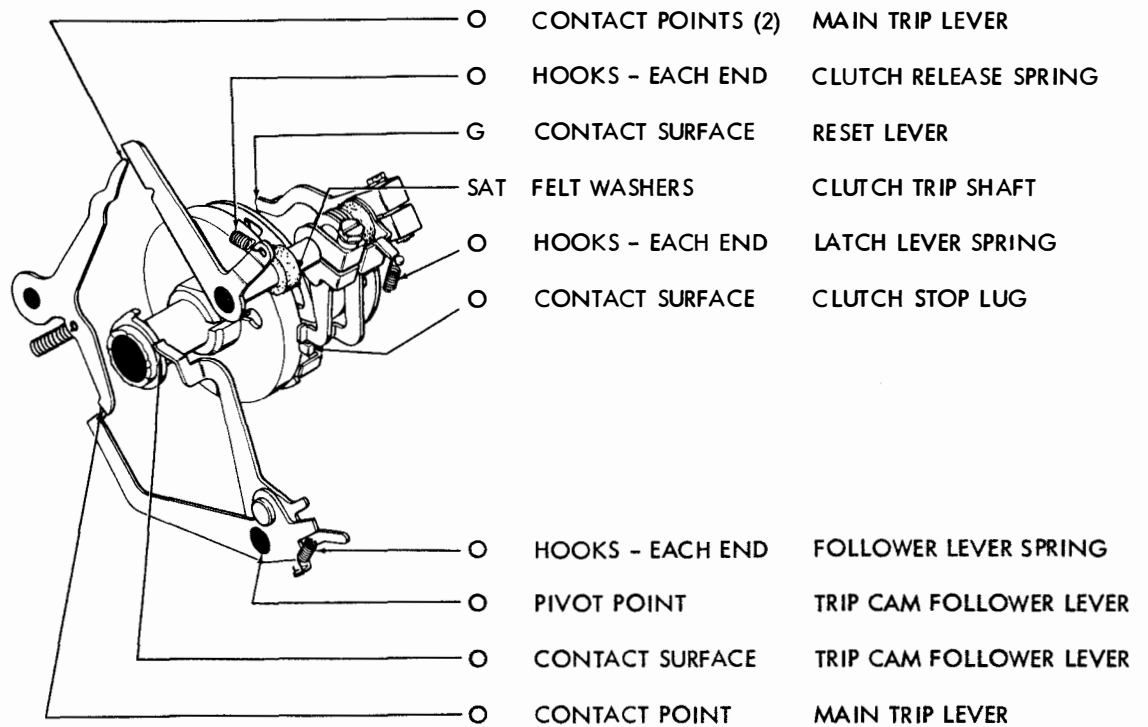

c. OIL RESERVOIR



d. MAIN SHAFT

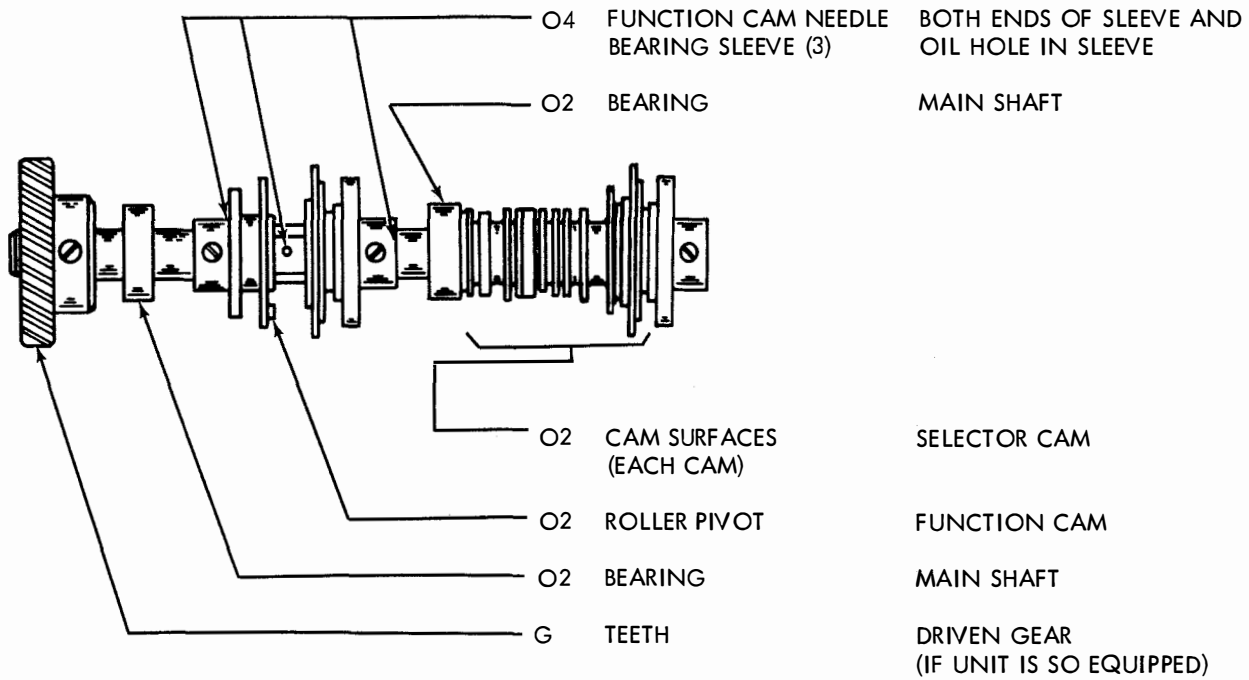

e. TIMING CONTACT BAILS

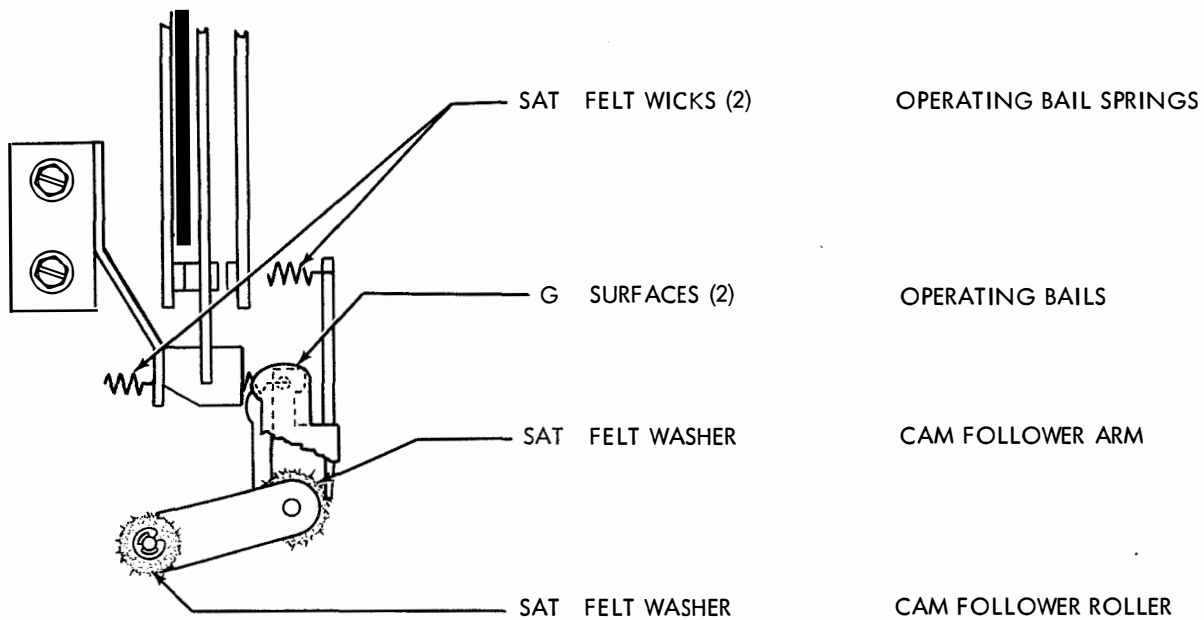



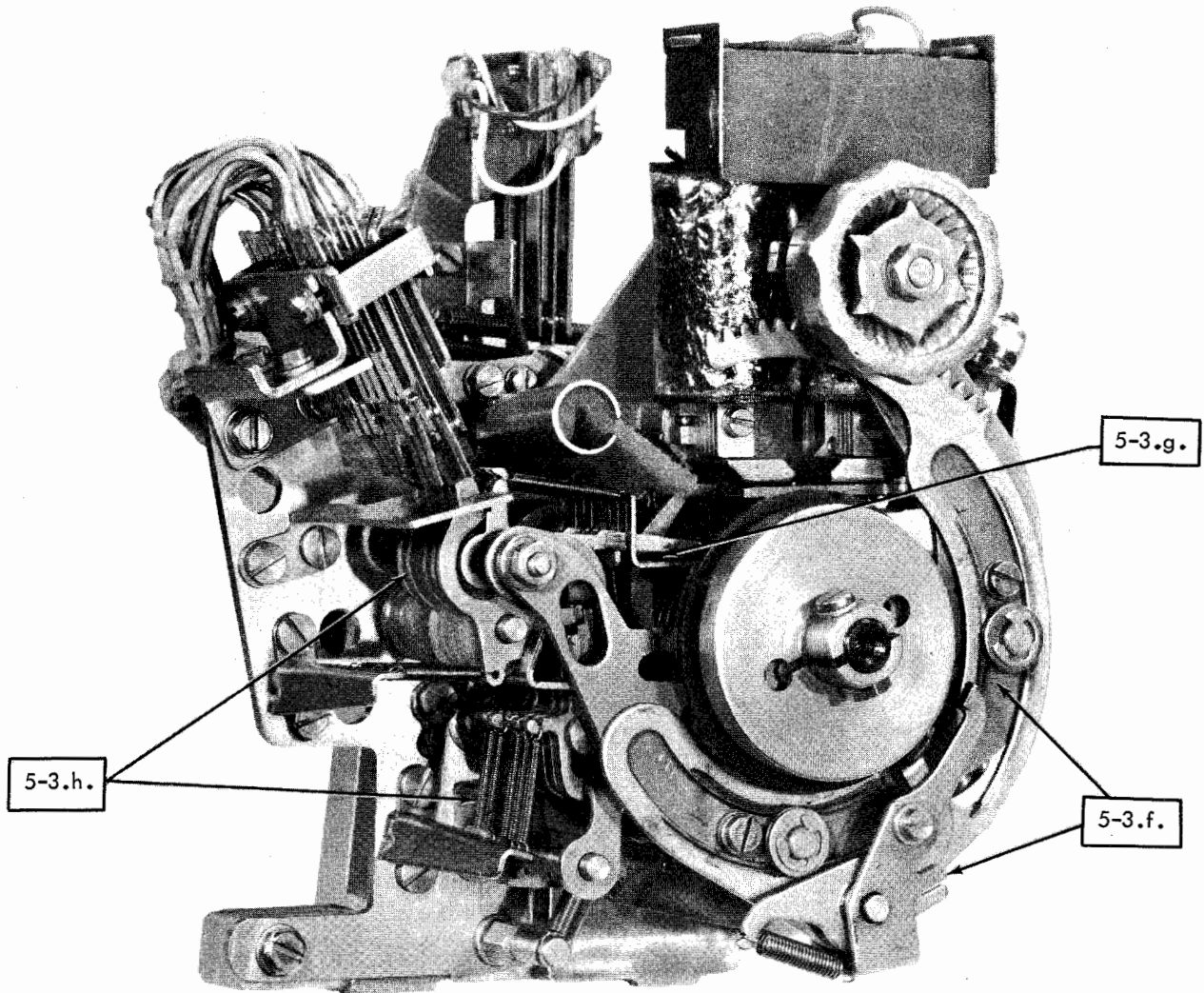

f. RANGE FINDER MECHANISM

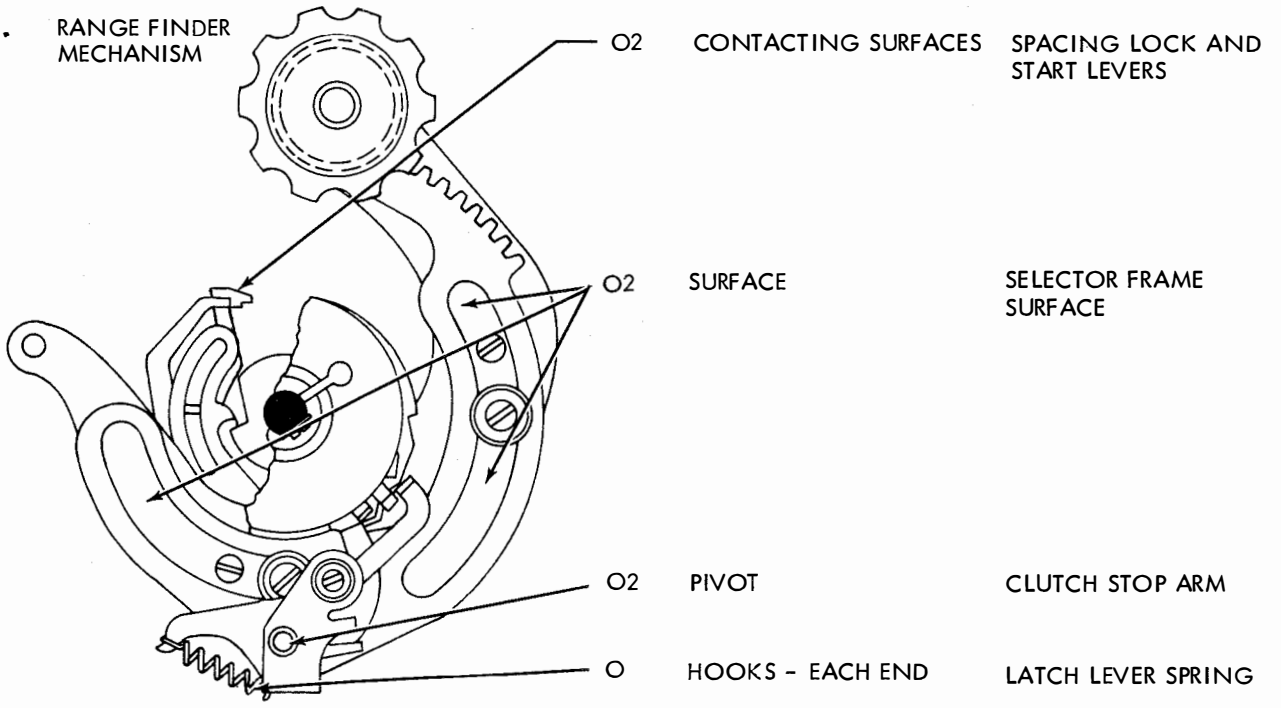

g. SELECTOR LEVER AND SPRINGS

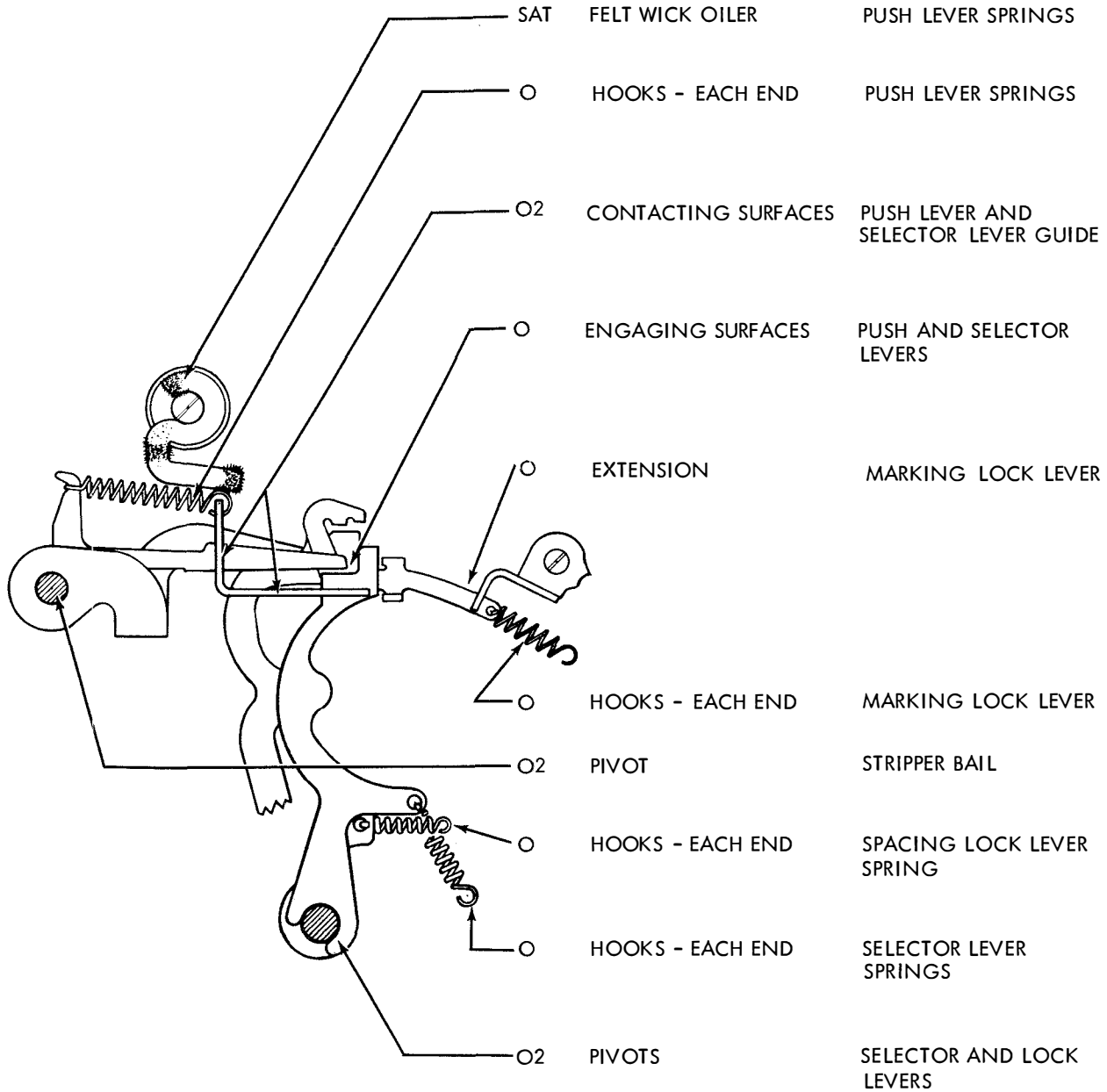

h. ACTUATOR LATCHES AND SPRINGS

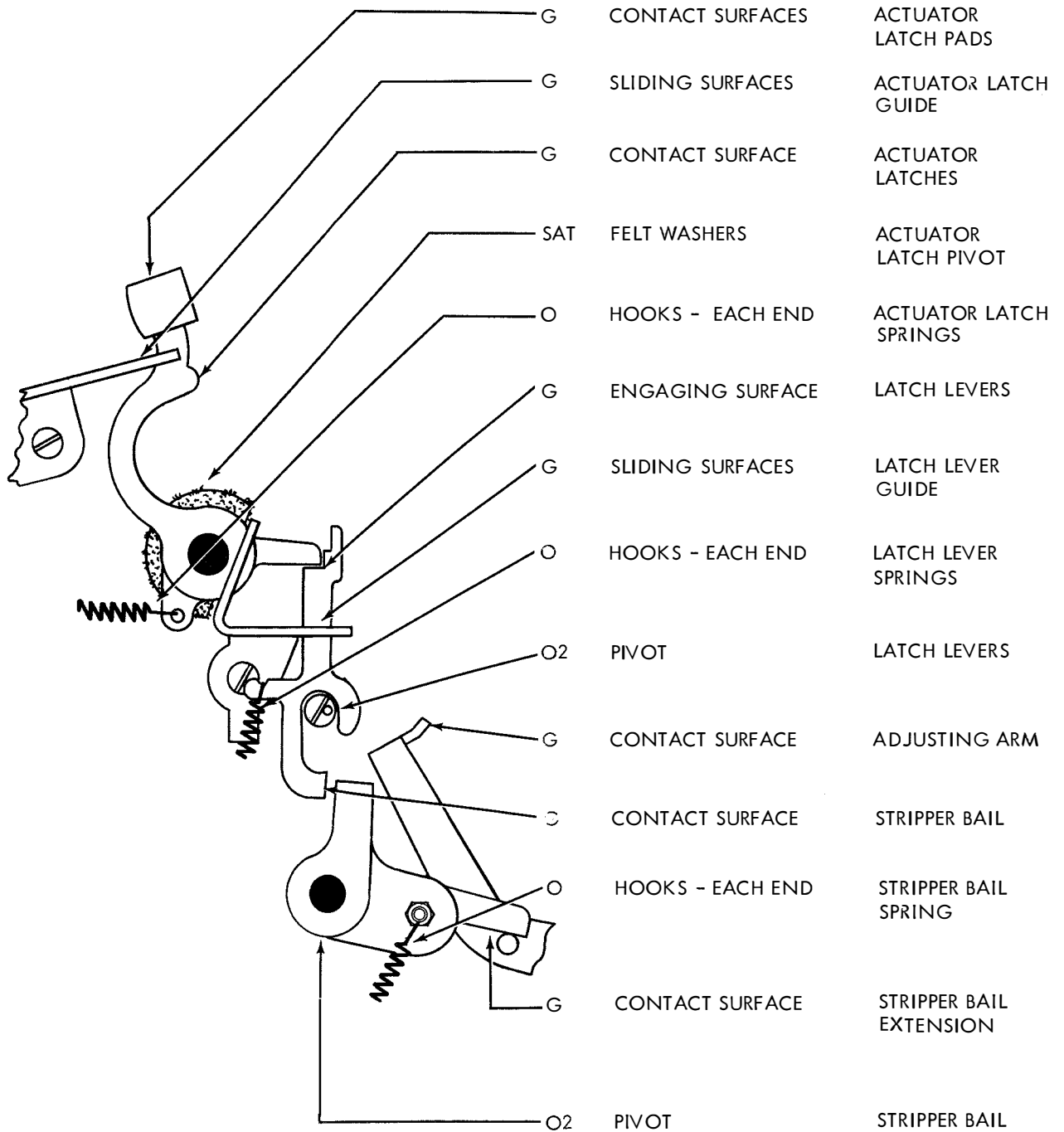

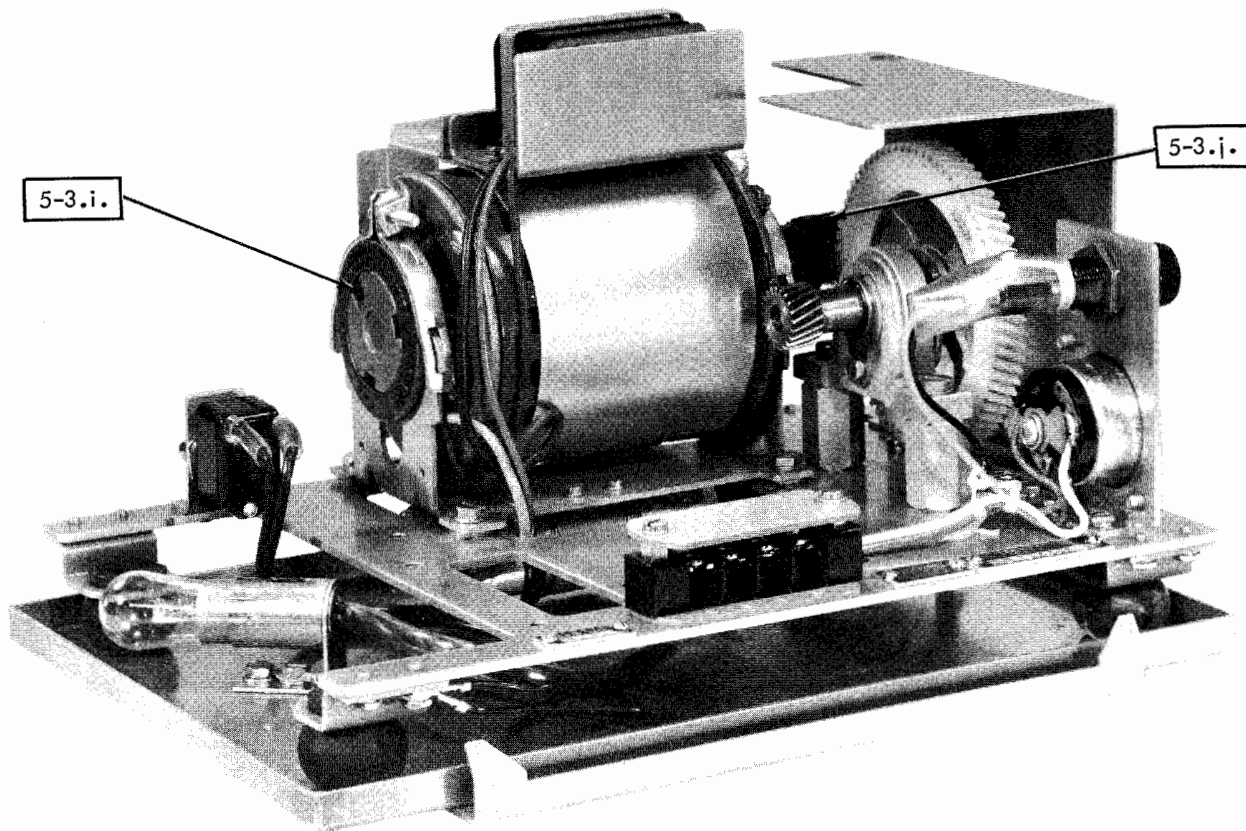

i. MOTOR AND GEARS

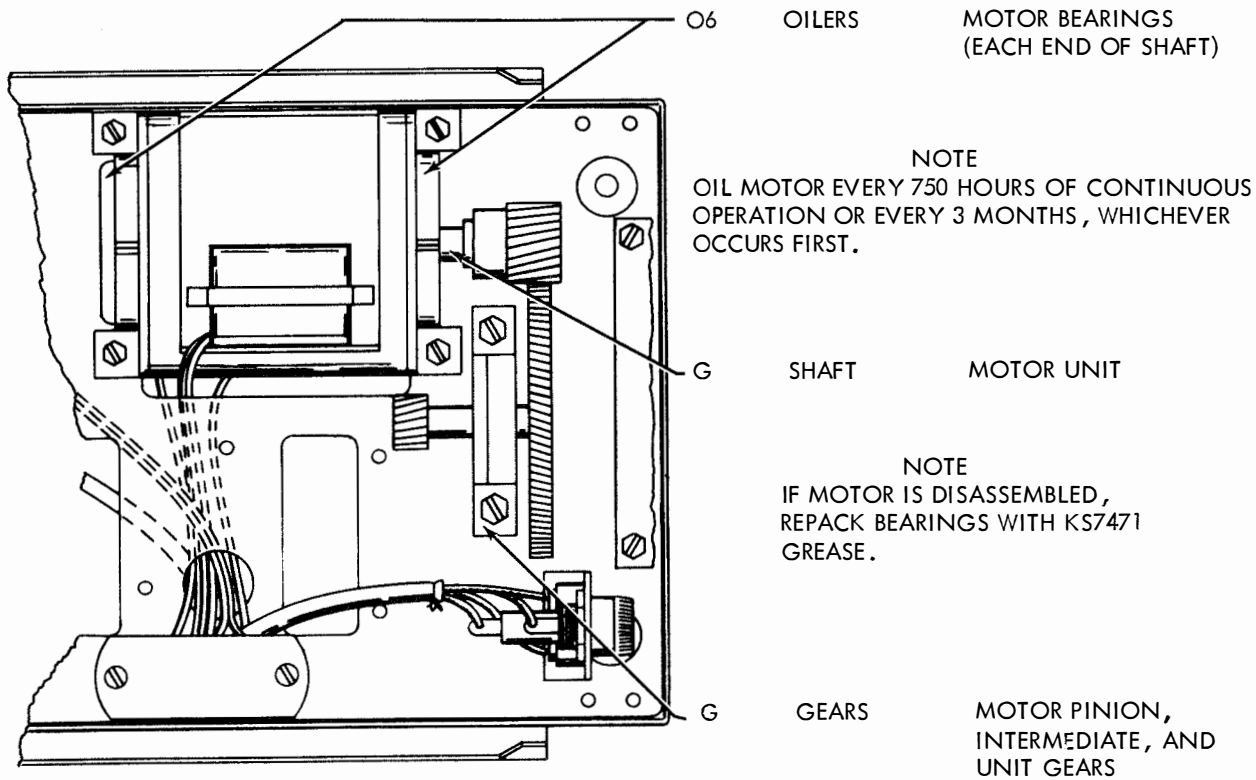

## SECTION 6

## PRINCIPLES OF OPERATION

## 6-1. INTRODUCTION

This section covers the operating principles of the Model 28 (LRS) Receiving Selector Set. The purpose of this section is to provide interested personnel with a detailed explanation of the electro-mechanical operation of the Set. A clear understanding of how the unit operates will be especially useful to maintenance personnel involved in trouble shooting the equipment.

## 6-2. CODE

a. The information handled by the Receiving Selector is in the form of a binary permutation code. The units of information - characters, numerals, etc. - are represented by combinations of binary intelligence levels (bits), each of which may be in one of two states, i. e., on-off, mark-space, yes-no, etc. Different versions of the equipment will accommodate codes whose combinations consist of either five or eight levels. The total number of permutations available in a given code is equal to two to the  $n$  power ( $2^n$ ) where  $n$  is the number of levels. For example, the permutations that can be expressed by a five level code is equal to two raised to the fifth power, or 32.

b. The code (as used by this equipment) is expressed in electrical form only. Each level of the code combinations consists of either a current condition (referred to as a marking pulse) or a no-current condition (spacing pulse). The intelligence elements are preceded by a start element (always spacing) and are followed by a stop element (always marking). The start and stop elements provide for mechanical synchronization between the transmitting unit and the Receiving Selector Set.

c. The five level version of the Receiving Selector Set is designed to accept a 7.42 unit code transmission pattern, while the eight level version accepts an 11.00 unit code transmission pattern. Figure 6-1 illustrates both the 7.42 and 11.00 unit code patterns, and the character arrangements for standard five level code.

## 6-3. RECEIVING SELECTOR SET OPERATION

## a. Summary of Operation

(1) The Receiving Selector Set is designed to receive neutral direct current signals, and can be wired to operate at either 0.020 or 0.060 ampere line current. 60, 75, or 100 WPM operation is possible, depending on the gear set used (see paragraph 1-6). Figure 6-9 is a block

diagram of the set. Operation of the Set, as represented by the figure, is described below.

(2) A.c. power is fed to the Motor Unit through the a.c. power switch. When the switch is ON, the motor converts the electrical power into rotary mechanical motion. This mechanical motion is transmitted to the main shaft of the Receiving Selector via the intermediate gear assembly.

(3) As long as a.c. power is applied to the motor unit, the LRS main shaft rotates continuously. The start pulse of each code combination causes the selector magnet armature to trip the selecting cam-clutch. Driven by the main shaft, the cam-clutch begins its cycle and imparts timed motion to the selector, which converts the code combinations into corresponding mechanical arrangements. Near the end of each selecting cycle, the selecting cam-clutch trips the function cam-clutch and permits the actuator latch levers to receive the arrangements from the selector. The selecting cam-clutch is then disengaged by the stop pulse of the code and remains inoperative until the next start pulse is received.

(4) The actuator latch levers transfer intelligence from the selector, in the form of mechanical arrangements, to the code reading contact assembly. Here the intelligence is stored until the next code combination is received by the Receiving Selector.

## b. Motor Unit

(1) The initial starting current causes the start relay to pull up, and its contacts to close the auxiliary winding circuit (see Figure 6-10). As the rotor gains speed, the current flowing through the relay coil decreases. When a predetermined current value is reached the relay armature is released, the relay contacts are opened, and the auxiliary winding circuit is disconnected from the line. The rotor continues to accelerate until it reaches synchronous speed (3600 RPM). The motor is wired in such a manner that the shaft rotates in a clockwise direction when viewed from the pinion end. (Refer to paragraph 1-7. e. for detailed technical data.)

(2) The capacitor and thermal cut-out switch are located below the motor, mounted on the motor mounting bracket. The starting relay is mounted on the bracket assembly, and sits above the motor. The thermal cut-out switch is in series with both the main and the auxiliary windings. If excessive current is drawn by the

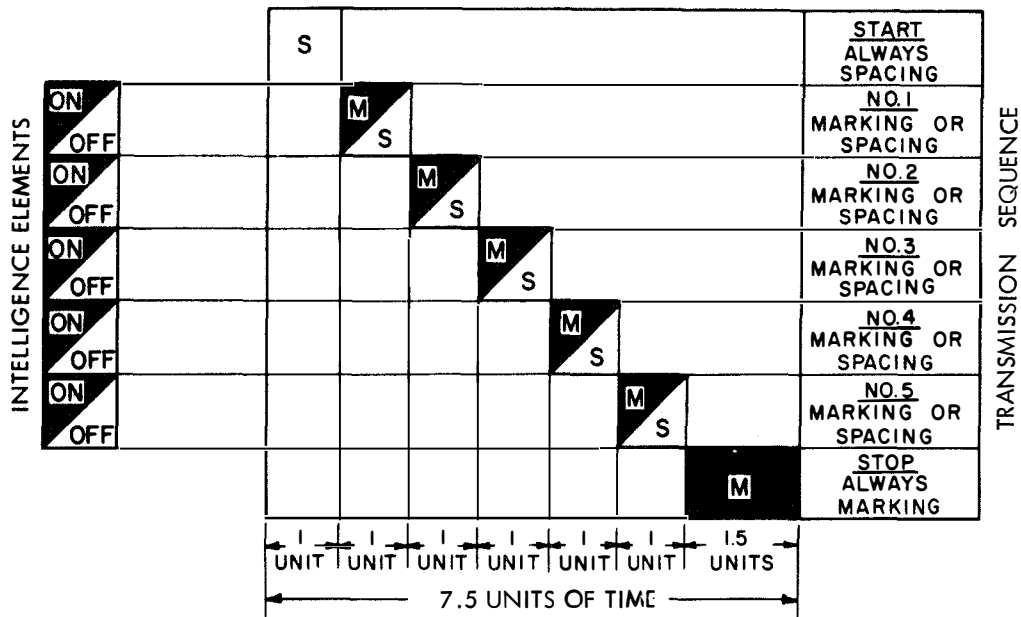

a. FIVE LEVEL PERMUTATION CODE

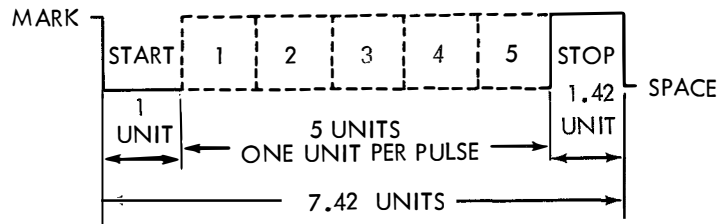

b. FIVE LEVEL START-STOP SIGNALING CODE

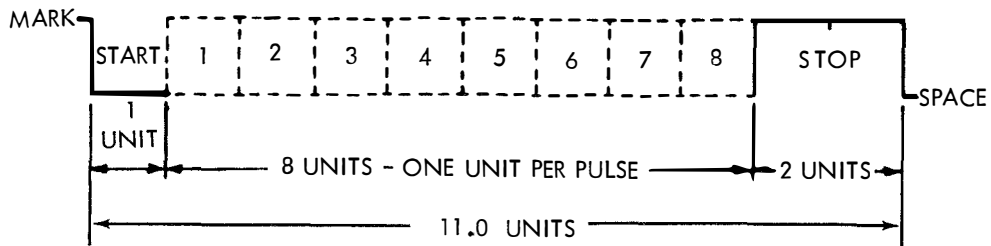

c. EIGHT LEVEL START-STOP SIGNALING CODE

FIGURES	-	5/8	3/4	3	1/4	8	8	'	1/2	3/4	7/8	9	0	1	4	BELL	5	7	3/8	2	/	6	"	BLANK	LETTERS	FIGURES	SPACE	CARRIAGE	LINE	FEED
LETTERS	A	B	C	D	E	F	G	H	I	J	K	L	M	N	O	P	Q	R	S	T	U	V	W	X	Y	Z				
1	●	●		●	●	●				●	●					●	●		●	●	●	●	●	●	●	●	●			
2	●		●				●		●	●	●	●				●	●	●			●	●	●			●	●			●
3		●			●		●	●	●	●	●	●				●	●	●			●	●	●	●		●	●			●
4		●	●	●		●	●		●	●	●	●	●			●					●	●				●	●			●
5		●					●	●				●	●	●	●		●				●	●	●	●	●	●	●			●

d. TYPICAL FIVE LEVEL CHARACTER ARRANGEMENTS

FIGURE 6-1. CODE

motor for any reason, the switch will open the circuit and prevent possible damage to the motor. The switch may be manually reset by depressing the red button projecting upward through the motor mounting plate and motor shield.

#### CAUTION

Allow the motor to cool at least 5 minutes before manually resetting the thermal cut-out switch.

(3) Two fans are located within the motor housing, one at each end of the rotor. The fans draw cooling air through the slots in the end bells, and exhaust it through the motor housing slots. Rubber vibration mounts isolate the motor from its mounting bracket. The mounts are held in the bracket by mounting straps. The motor shaft has a tapped hole which is used to mount the motor pinion gear. All motor shaft end play is taken up by a spring washer which bears

against the outer race on one of the bearings. The function of the motor shield is to isolate the cool air intakes from the hot air exhaust slots.

#### c. Receiving Selector

##### (1) Selecting Mechanism (Figure 6-2)

(a) The selecting mechanism consists of the selector magnet coil and armature, a selector cam-clutch, and associated levers, arms, bails, and slides. Essentially, the selecting mechanism is a signal converter. The incoming sequential signal (in electrical form) is converted into a mechanical arrangement of levers which stores the code in parallel form. From the selecting mechanism, the code is mechanically "passed on" to the Transfer Mechanism (see paragraph 6-3.c.(2), which transfers the signal intelligence from the selecting mechanism to the code reading contacts.

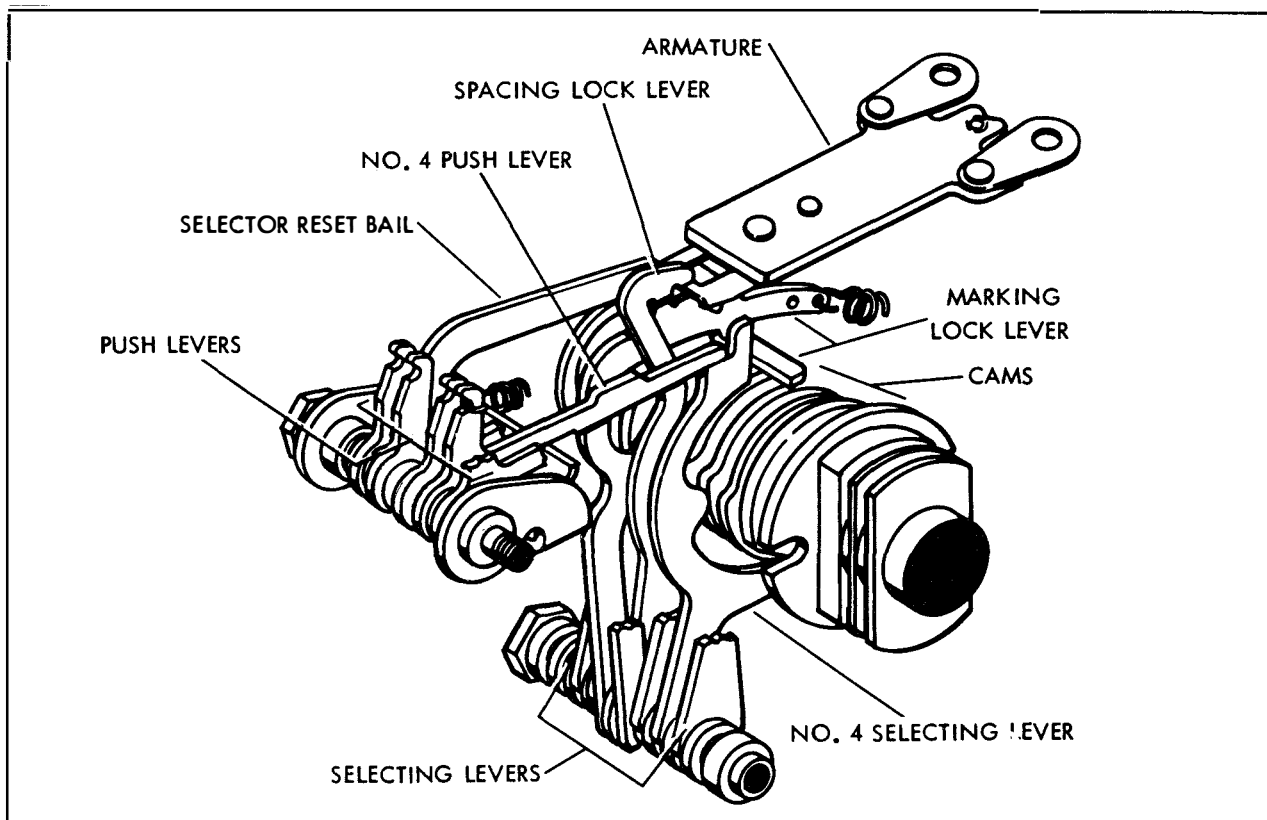

FIGURE 6-2. SELECTING MECHANISM

(b) The selector cam-clutch comprises, from right to left (Figure 6-3): the clutch, stop arm bail cam, the fifth, fourth, and third selector lever cams, the cam for the spacing and marking lock levers, the second and first selector lever cams, the push lever reset bail cam, and the function clutch trip cam.

(c) During the time in which a closed line circuit (marking) condition exists, the selector magnet coils are energized and hold the selector armature against the selector magnet pole pieces. In this stop position, the selector armature blocks the start lever (Figure 6-4). When the signal for any character or function is being received, the start (spacing) element releases the selector armature which, under the tension of its spring, moves away from the magnet cores and unlatches the start lever. The start lever turns clockwise under the tension of its spring, and moves the stop arm bail into the indent of its cam. As the stop arm bail rotates about its pivot point, the attached stop arm is moved out of engagement with the clutch shoe lever. The selector cam-clutch engages and begins to rotate. The stop arm bail immediately rides to the high point of its cam and holds the start lever away from the selector armature

during the signaling time. When the stop element at the end of signal is received, the selector armature is pulled up to block the start lever. The stop arm bail is prevented from dropping onto the low part of its cam (stop position of cam-clutch), and the attached stop arm is held so as to stop the clutch shoe lever. The selector clutch cam disk, upon which the latch lever rides, has an indent at its stop position. When the clutch shoe lever strikes the stop arm, the inertia of the cam disk assembly causes it to continue to turn until its lug makes contact with the lug on the clutch shoe lever. At this point, the latch lever drops into the indent in the cam disk, and the clutch is held disengaged until the next start element is received.

(d) The selecting levers, a marking lock lever, and a spacing lock lever ride their respective cams on the selector cam-clutch. As the marking and spacing signal elements are applied to the selector magnet, the selector cam-clutch rotates and actuates the selector levers. When a spacing impulse is received, the marking lock lever is blocked by the end of the armature and the spacing lock lever swings toward the right above the armature and locks it in the spacing position until the next

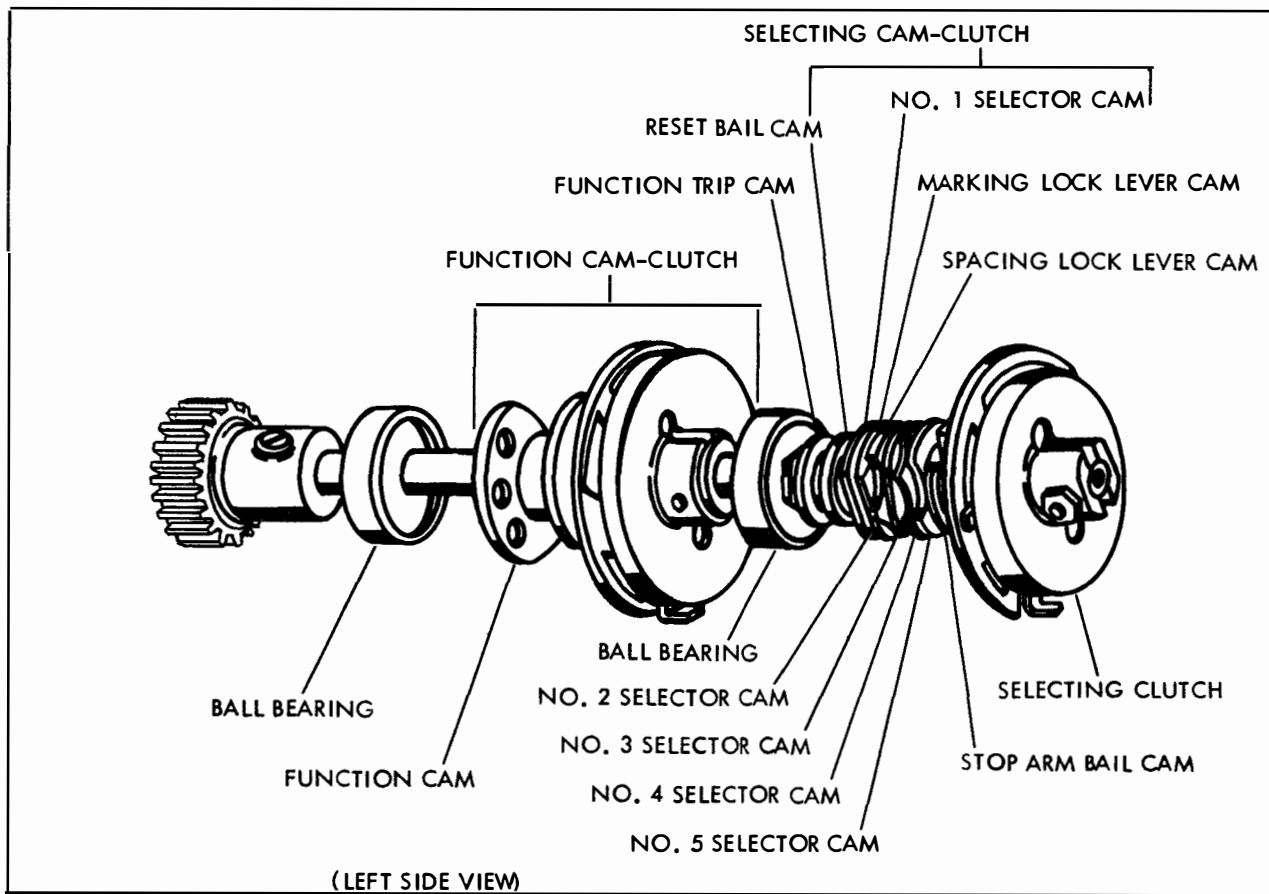

FIGURE 6-3. SELECTOR CAM-CLUTCH ASSEMBLY



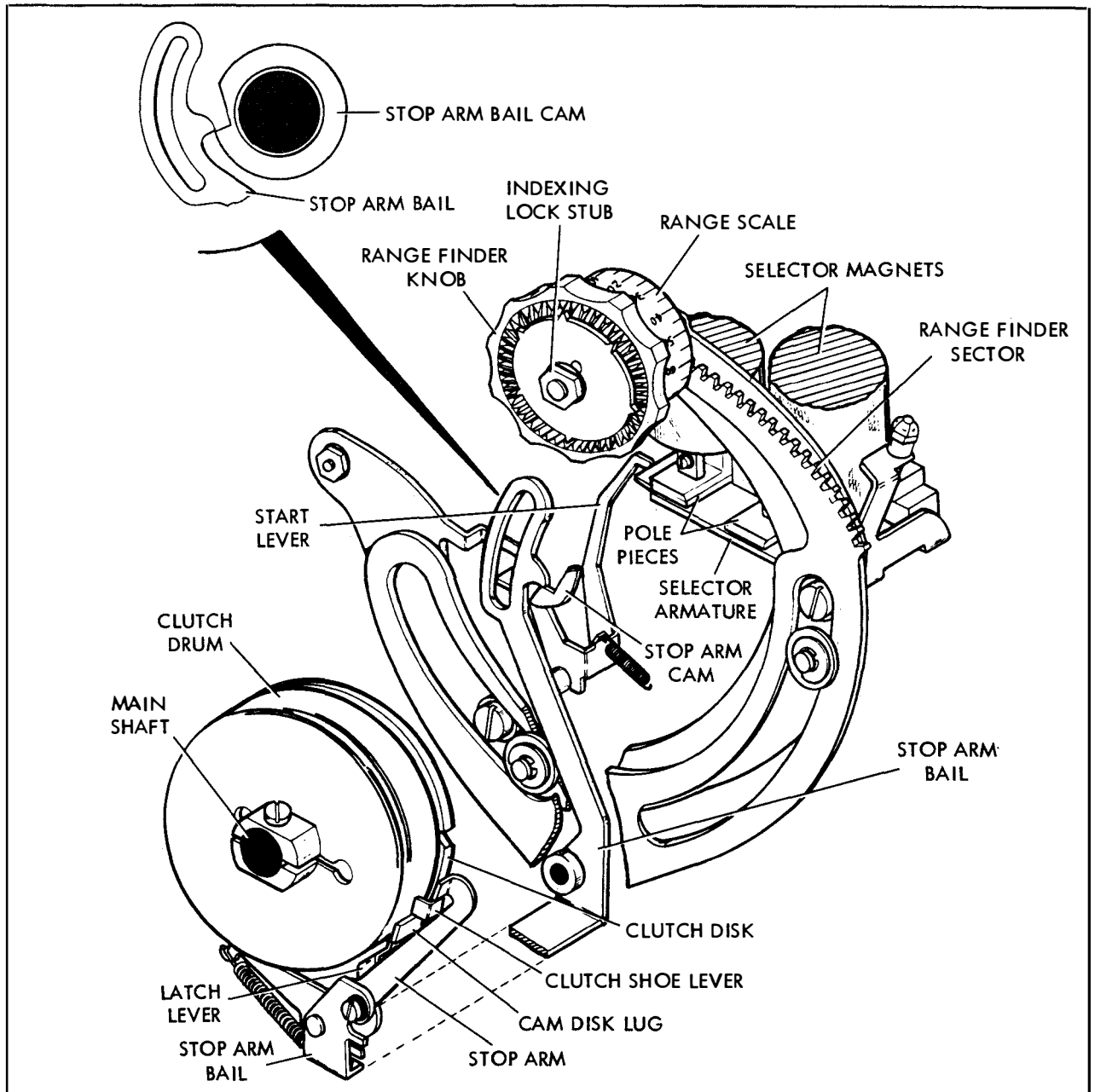

FIGURE 6-4. RANGE FINDER AND SELECTING CAM-CLUTCH TRIP ASSEMBLY

signal transition is due. Extensions on the marking lock lever prevent the selector levers from following their cams (Figure 6-2). When a marking element of the signal is received, the spacing lock lever is blocked by the end of the armature and the marking lock lever swings to the right below the armature to lock it in the marking position until the next signal transition is due. During this marking condition, the selector levers are not blocked by the marking lock lever extensions but are permitted to move against their respective cams. The selecting lever that is opposite the indent in its cam, while

the armature maintains a marking condition, swings to the right or selected position momentarily. Each selecting lever has an associated push lever which drops into a notch on the top of the selecting lever when it falls into its cam indent. As the selector cam rotates, the selecting levers - together with their selected push levers - are moved to the left and held there until all the code impulses have been received. Each selected push lever engages an associated actuator latch lever of the Transfer Mechanism. After the last push lever is selected, the latch lever stripper ball rotates the latch levers to the right

and clears the previous code combination from the code reading contact assembly. Any unselected actuator latch levers will move right, under spring tension, to the spacing position. Further rotation of the selector cam results in engagement of the function clutch (see paragraph 6-3.c.(5)), and storage of the selected code combination on the code reading contact assembly (see paragraph 6-3.c.(3)).

(2) Transfer Mechanism (Figure 6-5)

(a) The function of the transfer mechanism is to transfer the signal intelligence, mechanically stored in the selecting mechanism, to the code reading contact assembly. The transfer mechanism consists of a series of actuator latch levers, associated latches, a stripper (or reset) bail, and necessary springs and guides.

(b) There is an actuator latch for each code level. The latches pivot about the same fixed axis, and are engaged by the selector push levers at a point above their center of rotation. Each actuator latch is tipped with an insulated pad to isolate the lever from the contact swinger, when the two are in contact.

(c) Upon receipt of a marking code pulse, a selector push lever is selected (refer to paragraph 6-3.c.(1)). As the selector

cam rotates, the push lever moves to the left, engages its associated actuator latch lever, and rotates it counter-clockwise. As the actuator latch lever rotates counter-clockwise, an associated latch lever, which is spring biased against the actuator latch extension, falls under the extension and locks the actuator latch in place. (If a spacing code pulse is received, the selector push lever remains in its unselected position, and does not move left to engage its associated actuator latch lever. Consequently, the actuator latch lever remains in, or moves to, the spacing position.) As the selector cam continues to rotate, the follower lever rides to the high part of its cam, and operates the latch lever stripper bail and the main trip lever (paragraph 6-3.c.(5)). The stripper bail rotates counter-clockwise and bears against the latch levers, rotating them clockwise. This permits all previously selected (marking) actuator latches - if not selected during this cycle - to return to the unselected (spacing) position. Operation of the stripper bail occurs just before the main trip lever allows the function clutch release arm to rotate clockwise, engaging the function clutch.

(3) Code Reading Contact Assembly

(a) The code reading contact assembly consists of a bank of transfer type contacts, one set of contacts for each code level. The assembly mounts on an adjustable bracket,

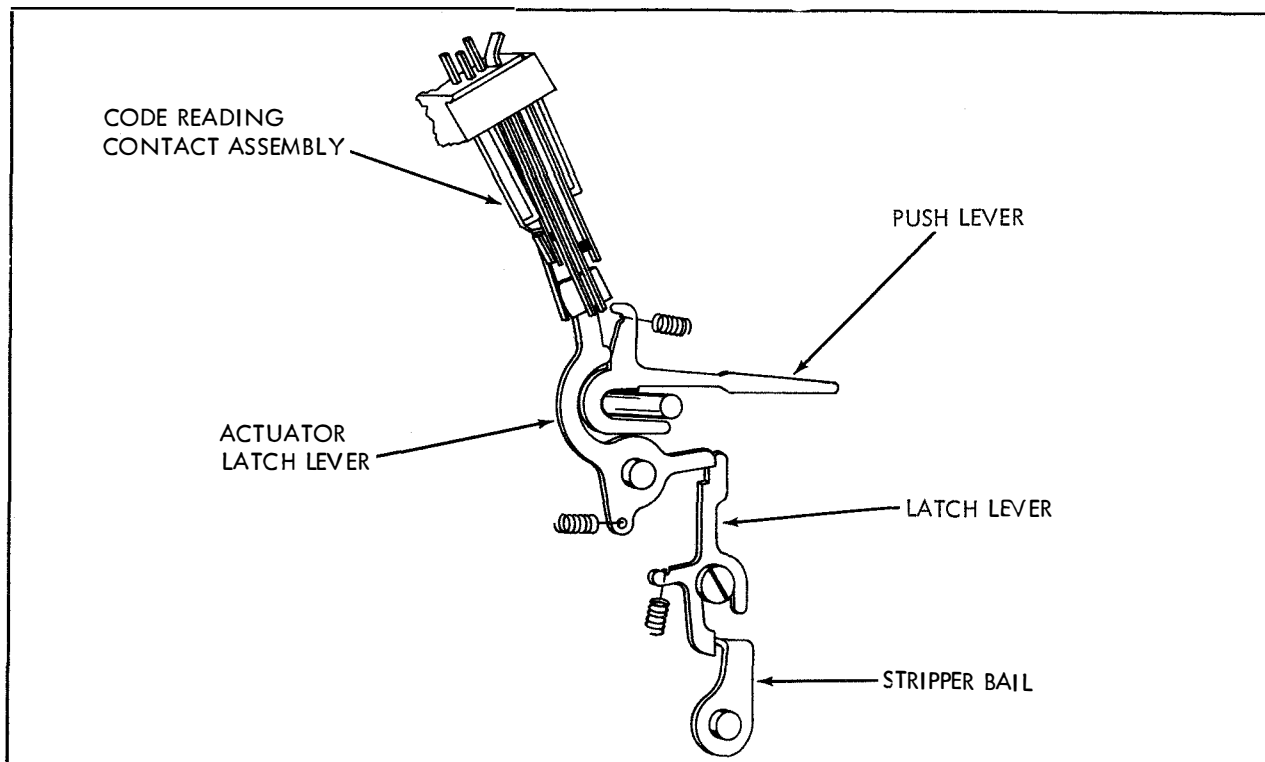

FIGURE 6-5. TRANSFER MECHANISM

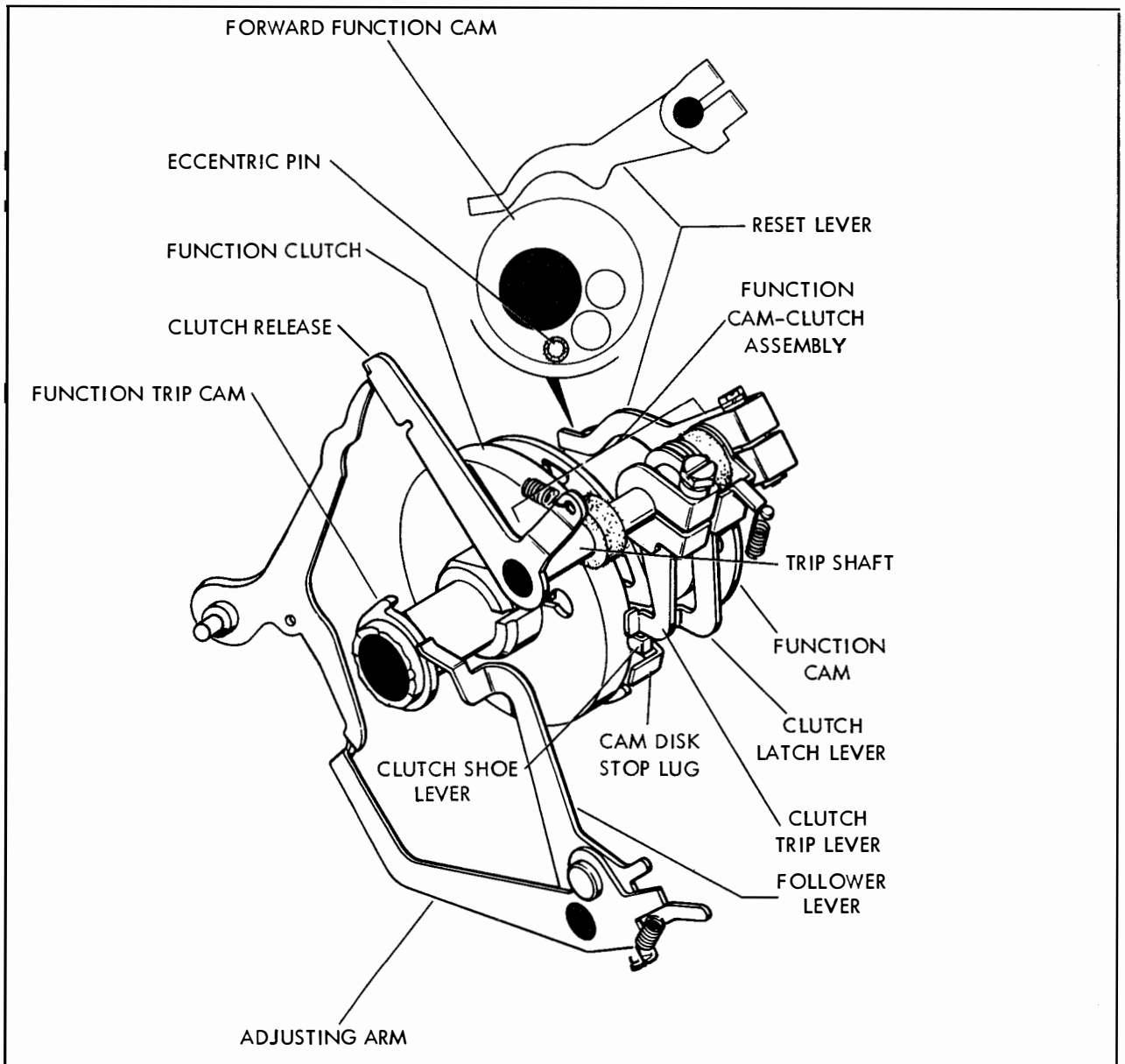

FIGURE 6-6. FUNCTION CAM-CLUTCH AND CLUTCH TRIP ASSEMBLY

and is located at the front of the unit immediately left of the transfer mechanism. Its function is to store the signal information transferred from the selecting mechanism by the transfer mechanism, for parallel wire output.

(b) The swingers of the contact assembly are operated by associated actuator latch levers. The selected code combination is stored in the contact assembly until it is "wiped off" when a new code selection is transferred from the selecting mechanism. The storage of a marking or spacing pulse is determined by the position of the transfer contacts, via operation of the selecting and transfer mechanisms (refer to paragraphs 6-3.c.(1) and (2)). A marking

pulse results when the normally closed contacts are opened, and a spacing pulse results when the normally closed contacts remain closed.

#### (4) Orientation

(a) For optimum performance, the selecting mechanism should be adjusted to sample the signaling code elements at the most favorable time. To determine this adjustment, the operating margins are established through the range finder, which provides a means of varying the time of sampling.

(b) When the range finder knob (Figure 6-4) is pushed inward and rotated, its

attached range gear moves the range finder section (which mounts the stop arm bail, stop arm and latch lever) either clockwise or counterclockwise about the selector cam-clutch. This changes the angular position at which the selector cam-clutch stops with respect to the selecting levers. When an optimum setting is obtained, the range finder knob is released. Its inner teeth engage the teeth of the indexing lock stud and lock the range finder mechanism in position. The setting may be read on the range scale opposite the fixed index mark.

#### (5) Function Cam-Clutch and Clutch Trip Assembly (Figure 6-6)

(a) The main trip lever is rotated counterclockwise by the selector cam clutch when the function trip cam raises the follower lever near the end of the selecting cycle. After reaching the high part of the trip cam, the follower immediately returns to its unoperated position. This places the main trip lever in a free condition, allowing it to move under the clutch release when the trip shaft raises the release. The latch lever stripper bail extension is engaged by an extension on the adjusting arm, and acts to release the unselected actuator latch levers (see paragraph 6-3.c.(2)). The upper arm of the main trip lever moves out of the way of the clutch release, which falls against a downstop and rotates the trip shaft counterclockwise. Immediately the trip lever latch allows the main trip lever to return toward its unoperated position, the upper arm moving down against the clutch release. When the trip shaft is rotated by the release, it moves the clutch trip lever out of engagement with the clutch shoe lever. The clutch engages to begin the function cycle.

(b) About midway through the function cycle, an eccentric pin on the function cam lifts a reset arm, which rotates the trip shaft clockwise. The clutch release is moved upward, allowing the main trip lever to rotate fully clockwise, raising the reset bail. The eccentric pin then moves out from under the reset arm, and the clutch release is permitted to return to its unoperated position against the main trip lever. When the cam-clutch assembly completes its cycle, the clutch shoe lever strikes the trip lever, and the clutch is disengaged.

(c) As the function cam assembly rotates, the rear function cam engages the roller on the cam follower arm of the timing contact assembly (paragraph 6-3.c.(6)). The cam follower arm operates the timing contact operating bails which, in turn, operate the timing contacts.

#### (6) Timing Contact Mechanism

(a) The timing contact mechanism consists of two separate transfer type contact assemblies, two contact operating bails and springs, and a cam follower arm. The mechanism is mounted to an adjustable frame, and is located at the rear of the Receiving Selector above the rear function cam. The timing contacts provide electrical pulses which may be synchronized with respect to the code reading contact pulses for control circuitry purposes.

(b) Each transfer type contact is operated by a bail that pivots on a common shaft. The bails are spring operated in one direction, and cam operated in the other. The rearmost contact operating bail is operated by the forward-most operating bail. In the stop position, both sets of normally open contacts are held closed by their operating bails. Rotation of the function cam, during the function cycle, results in operation of the timing contacts. During the first half of the cycle, the Y (or probe) contact is operated first, followed by the X (or common) contact. During the last half of the cycle, the contacts are returned to their stop position (i. e. normally open contacts held closed) in the reverse order.

#### (7) Selector and Function Clutch Operation

(a) When the selector clutch stop arm or the function clutch trip lever is tripped, the clutch shoes engage a serrated surface on the inside of the clutch drum. Since the clutch shoes are mounted on a plate that is part of the cam assembly (selector or function cam), the cam rotates upon engagement of the clutch.

(b) Figure 6-7 shows a clutch disengaged. Disengagement is caused by bringing together lug A on the cam clutch disk and the lower end of clutch shoe lever B. The upper end of lever B pivots about its ear C and allows its other ear D to move toward the right. The upper spring then pulls the two shoes together and away from the drum.

(c) Figure 6-8 shows the same clutch engaged. This is accomplished by releasing the lower end of lever B. The upper end of lever B pivots about its ear C (which bears against the upper end of the secondary shoe) and moves its ear D, and the upper end of the primary shoe, toward the left until the shoe makes contact with the drum at point E. As the drum turns counterclockwise, it drives the primary shoe downward, so that it again makes

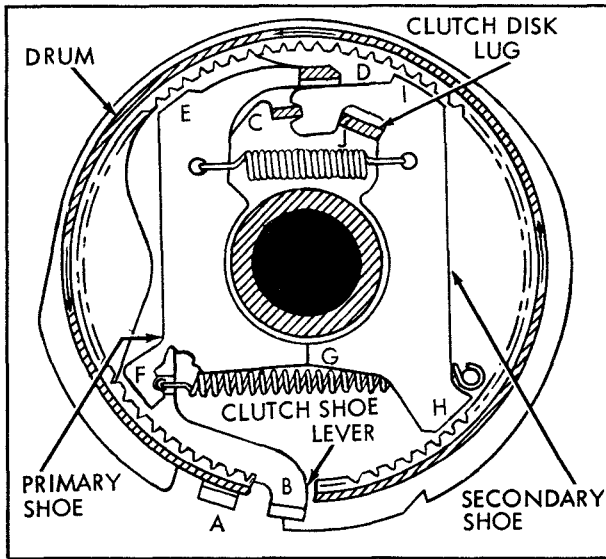

FIGURE 6-7. CLUTCH DISENGAGED

contact with the drum, this time at point F. There, the combined forces acting on the primary shoe cause it to push against the secondary shoe at point G. The lower end of the secondary shoe then bears against the drum at point H. The revolving drum acts to drive this shoe upward so that it again makes contact with the drum at point I. Since the

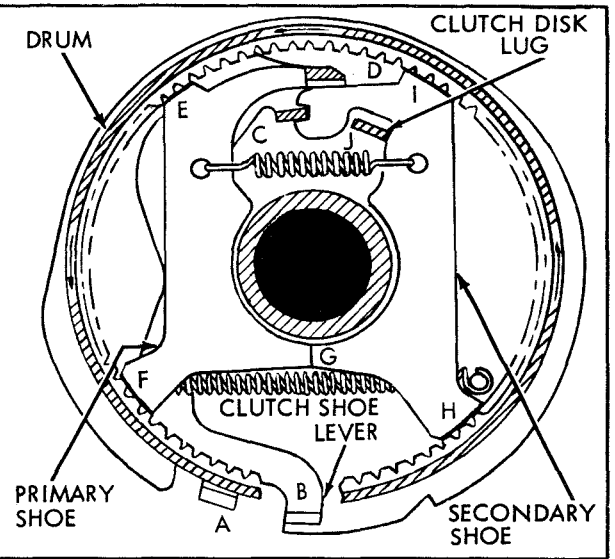

FIGURE 6-8. CLUTCH ENGAGED

forces involved are multiplied at each of the preceding steps, the final force developed at point I is very great. This force is applied to the lug J on the clutch-cam disk to cause it to turn in step with the drum. The cam disk is a part of the selector cam assembly, which rotates upon engagement of the clutch.



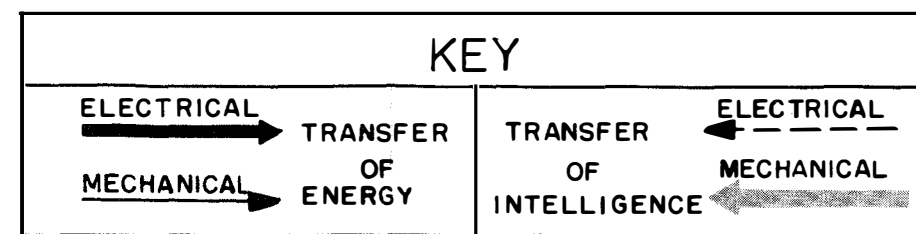
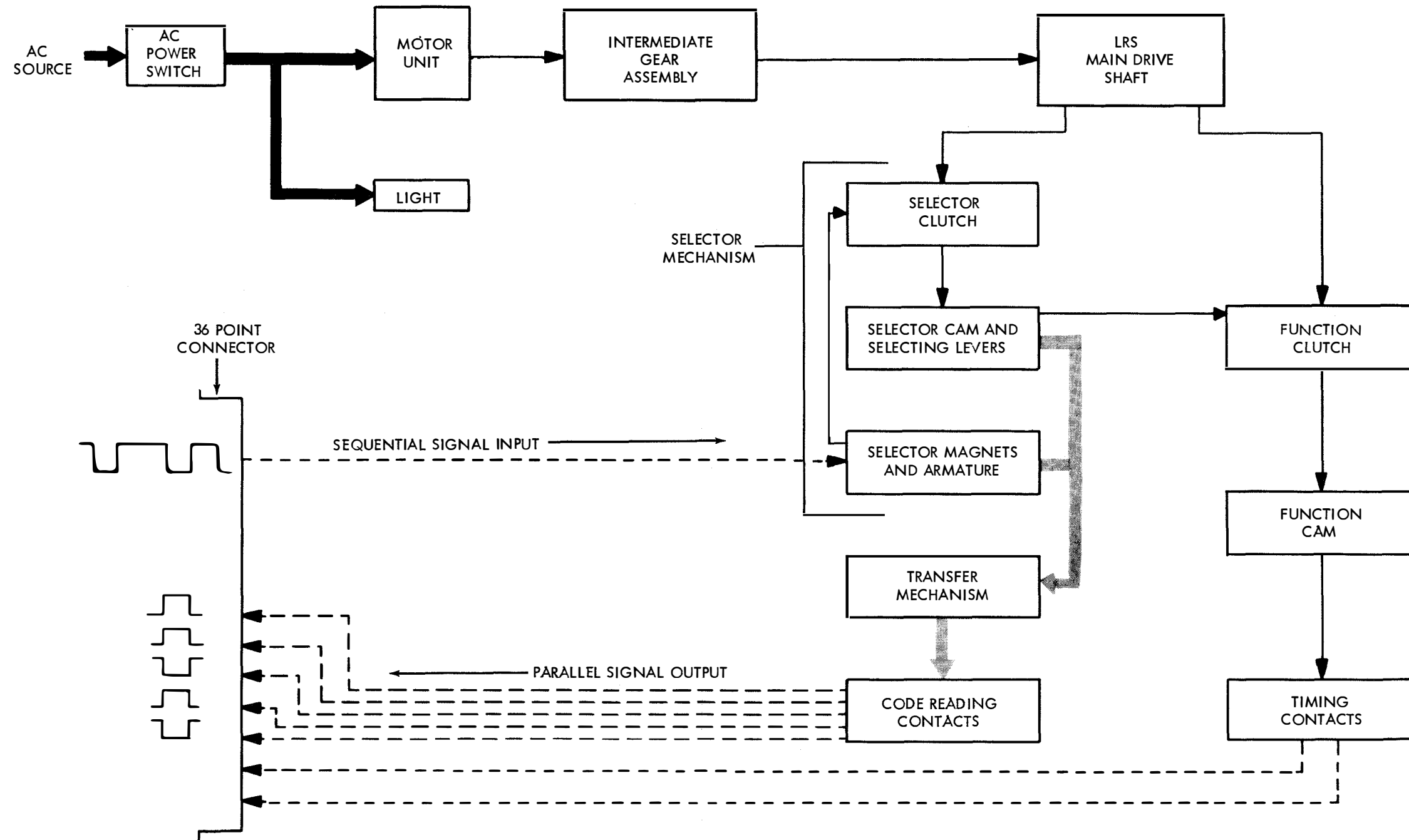

Fig. 6-9. Model 28 Receiving Selector Set, Block Diagram

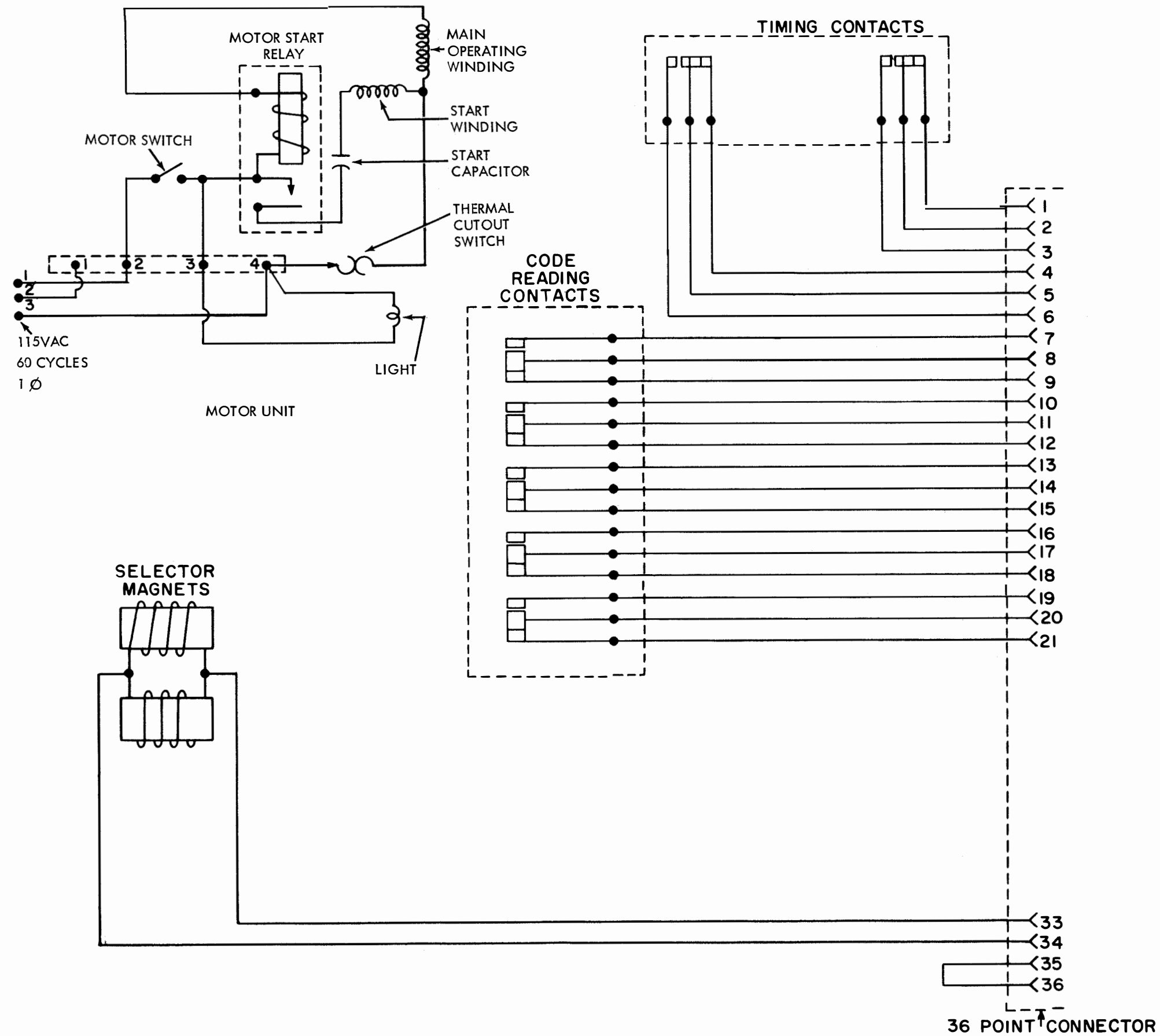

Fig. 6-10. Auxiliary Winding Circuit, Schematic Diagram