

## The Typing Reperforator and the Transmitter Distributor of the AN/FGC-58

**I**N ADDITION to the keyboard and page typer discussed in Chapter 5, the Model 28 ASR set contains two typing reperforators. One of these is shown in figure 138. This unit, the auxiliary typing reperforator, is mounted with a separate motor behind the transmitter distributor. The other unit, the keyboard typing reperforator, is shown to the left of the keyboard in figure 81 and is driven by the same motor which supplies power to the keyboard, the typer, and the transmitter distributor.

2. As with the page typer, one wonders how this collection of madly oscillating levers and quivering springs can remain together and perform so flawlessly—which it will do if accorded proper maintenance. The auxiliary typing reperforator responds to line signals only, while the keyboard unit can produce punched and printed tape from a line signal or through a mechanical linkage with the keyboard. The electrical selecting, perforating, and typing operations of the two units are identical.

3. We then conclude our study of the mechanical operation of the set with a discussion of the transmitter distributor.

### 26. Mechanical Operation of the Typing Reperforators

26-1. We know that both typing reperforators are identical in mechanical operation except for the fact that the keyboard typing reperforator is mechanically linked to the keyboard for local production of message tape. In this chapter we will direct our discussion towards the keyboard typing reperforator. Through it, you should also understand how the auxiliary typing reperforator operates.

26-2. After a general overview of the operation of the unit, let us see how a selection is made—first mechanically from the keyboard, then electrically via the line and the selector unit. We will then explore the method used by this machine to prepare punched and printed tape. The ma-

chine, of course, must also be able to perform the letters-figures shift and ribbon feed and reverse.

26-3. **General Information.** Operation of the keyboard typing reperforator is by electrical linkage when the selector switch is in the  $\kappa$ - $\tau$  position and by mechanical linkage when the selector switch is positioned for the T mode of operation. The keyboard selector switch mechanically disables the keyboard reperforator in both the  $\kappa$  and  $\kappa$ - $\tau$  positions. In the  $\kappa$  position, transmission is from the keyboard while the keyboard typing reperforator is idle.

26-4. How the keyboard typing reperforator responds when the selector switch is positioned to the  $\kappa$ - $\tau$  position will depend on the line circuit. It will produce the same message as that being transmitted by the keyboard. If the keyboard typing reperforator is connected to a different signal line from that servicing the basic equipment, the keyboard typing reperforator will be disconnected from the line circuit and put into connection with the local keyboard circuit when the selector switch is positioned for K-T operation. We will discuss this in greater detail in the final chapter of this volume.

26-5. Right now, we will examine how the keyboard reperforator—which becomes the keyboard perforator as it responds to the mechanical linkage whenever the machine is conditioned for T (tape only) operation. Next, we will study the reaction of the unit to electrical signal, which may come either from the local keyboard or the distant station. Once the code combination (either mechanically or electrically inspired) is registered in the punch slides of the reperforator, the rest of the operations of the machines are alike.

26-6. **Mechanical Selection.** You know that when the selector switch is in the  $\tau$  position, tape is perforated by the typing perforator but no signals are generated by the keyboard. When the ASR set is conditioned for the local production of tape, the mechanisms shown in figure 139 operate to set up the selection. After the printing and

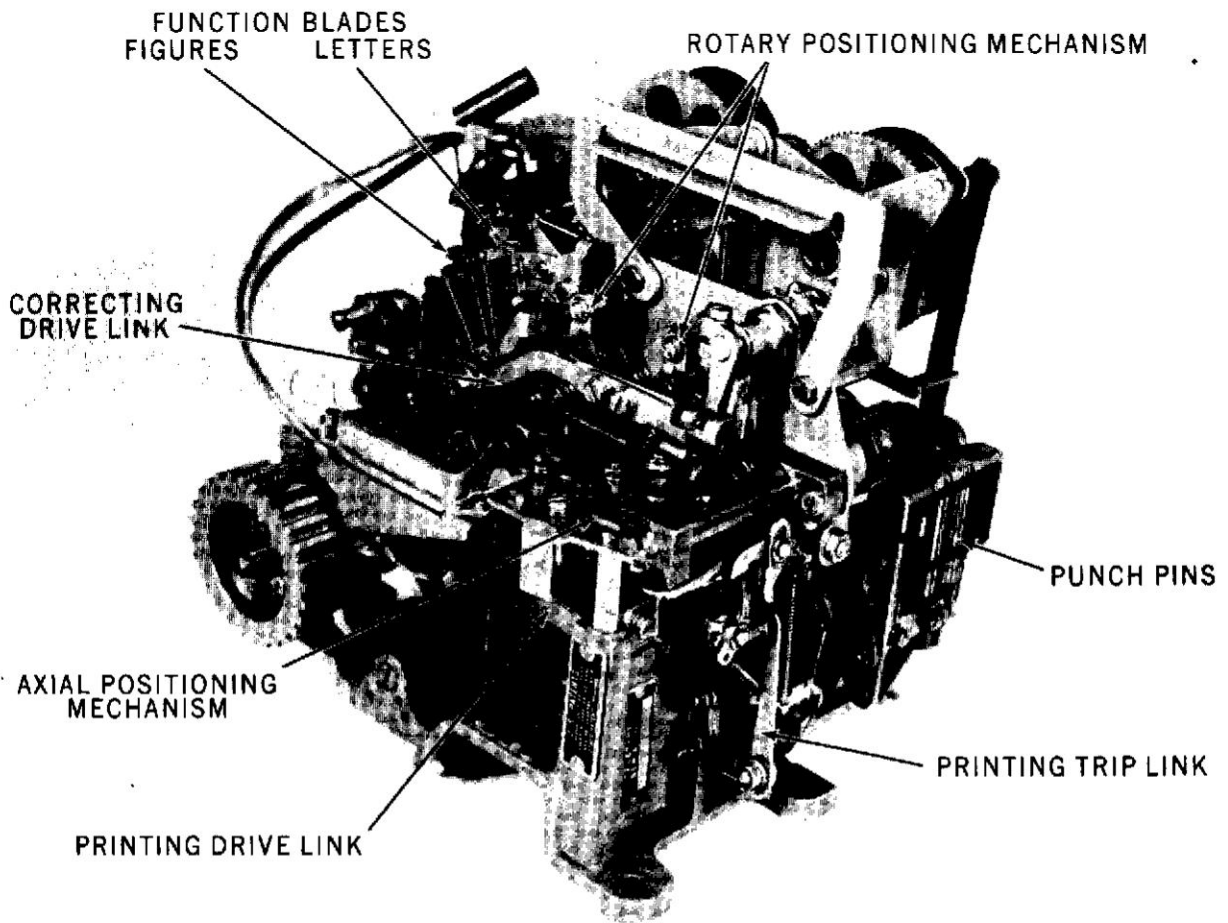

Figure 138. Typing reperforator.

perforating sequences are assured, the keyboard is reset by the typing perforator since the keyboard signal generator mechanism is inoperative.

26-7. When the selector switch is turned to the  $\tau$  position, in addition to changing the circuitry, it allows the components (shown in fig. 139) to operate. Find the selector switch located in the left center portion of the illustration and imagine that you are turning it to the  $\tau$  position. This will position the blocking bail at D, as shown. This movement to the right frees the code bar extensions so that they can follow the code bars to the right for a marking impulse. The blocking bail extension rotates the bell crank counterclockwise and into alignment with the clutch trip bar latch.

26-8. The large control cam on the selector switch shaft operates another group of levers and latches shown at the bottom of our illustration. Downward pressure against the control cam follower results in a clockwise rotation of the keyboard control selection lever. This places the pin at point K in line with the hook on the lower end of the reset cam follower reset lever. The right

end of the keyboard control selection lever falls so that it will not engage the keyboard signal generator clutch trip lever, and the signal generator shaft is inoperative. However, the signal generator can still be tripped by an incoming external clocking pulse unless the selector switch is rewired to keep the clutch trip magnet continuously energized when the switch is in the  $\tau$  position. The character counter is operative and causes the end-of-line indicator to light at the proper time. Let's see what happens when you depress a key top for a character.

26-9. *Character selection.* When a code key lever is depressed, the clutch trip bar is released and moves to the right. The lower end of the code bar bail also moves to the right, releasing the selected code bars as described in Chapter 5. Movement of the selected code bars allows the associated code bar extensions (E in fig. 139) to also move to the right under spring tension. The upper ends of the extensions (C in fig. 139) contact the punch slide latches (B) and rotate them counterclockwise. The clutch trip bar link in the center of figure 139 is pulled to the right by the clutch

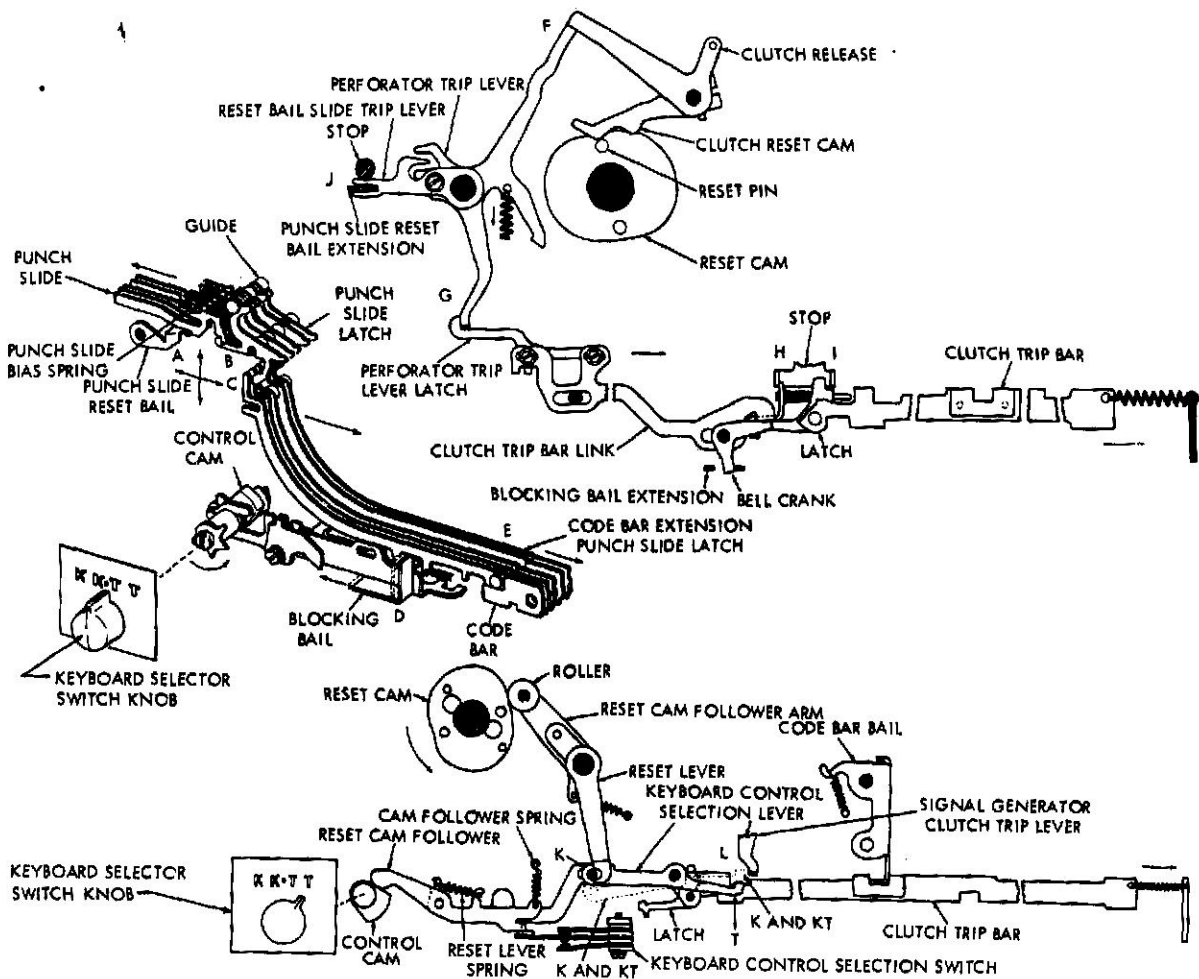

Figure 139. Mechanical linkage to keyboard.

trip bar. As you can see in the illustration, the clutch trip bar is coupled to the perforator trip lever latch. This latch, in turn, contacts the perforator trip lever at G in figure 139, causing it to rotate counterclockwise. As it does so, the perforator trip lever is disengaged from the clutch release at F. The clutch release falls under spring tension and releases the reperforator clutch trip lever which, in turn, trips the perforator function clutch, allowing the shaft to turn.

26-10. As the perforator trip lever rotates counterclockwise, it also imparts motion to the reset bail trip lever which is linked to it, as shown in figure 139. This pulls down an extension on the punch slide reset bail at point J. The reset bail moves downward, permitting the punch slides (A), which have been selected for marking, to move to the left under the tension of their springs.

26-11. *Reset.* As the clutch trip bar nears the end of its movement to the right, the upper portion of the latch comes in contact with the stop at point I in the illustration. The latch then pivots

counterclockwise, releasing the clutch trip bar link, which moves rapidly to the left under the action of the compression spring shown between H and I. The clutch trip bar link is stopped in its movement to the left by its extension striking the stop at point H. The perforator trip lever latch is to the left of, and completely free of, the perforator trip lever. As the clutch release pivots clockwise under the resulting action of the pin on the reset cam, the perforator trip lever is released from its counterclockwise position and allowed to rotate clockwise to its normal position, as shown at G in figure 139.

26-12. At the same time, the clutch trip bar is being reset and is moving to the left. As the latch moves to the left away from its stop at point I, it pivots clockwise to its normal position, so that when the clutch trip bar is at the extreme left of its reset travel, the latch is again allowed to hook under the clutch trip bar link to complete the cycle.

26-13. The code bars are also being reset at this time. This is accomplished by the reset cam on the perforator acting against the reset cam roller

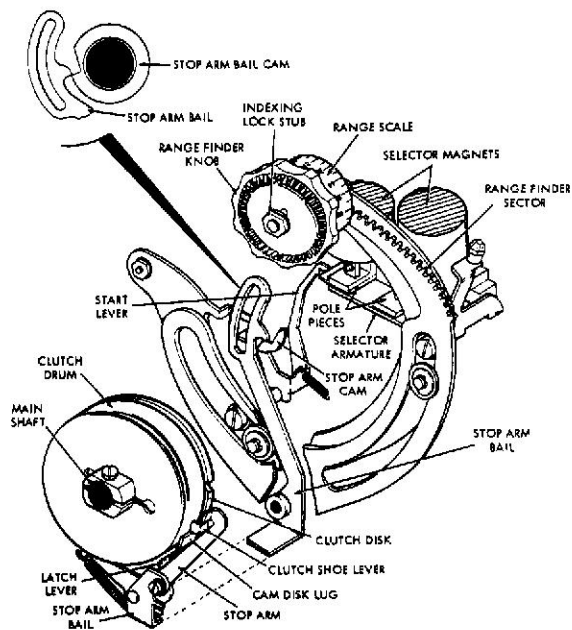

Figure 140. Rangefinder and selector cam-clutch assembly.

and reset cam follower arm which pivots on the keyboard base. When the key lever on the keyboard is depressed, the code bar bail and the clutch trip bar are released to move toward the right. The reset lever with the hook, shown at the bottom of figure 139, is in position to engage the pin of the keyboard control selection lever at point K. As the lower end of the reset lever moves to the left, it forces the clutch trip bar to the left. The code bar bail, moving to the left with the clutch trip bar, resets the code bars, and the bail latch holds the code bar bail and the bars to the left. As the reset bail continues to revolve, the reset lever moves back to the right to clear the pin at point K. This allows room for the movement of the clutch trip bar to the right when the next key lever is depressed.

26-14. Having seen how the perforator responds to the mechanical input from the keyboard, let us assume that the typing reperforator is receiving a code combination in the selector magnets. Now we'll see how the machine responds to the signals and positions the punch slides to correspond to the electrical signal input.

26-15. **Electrical Selection.** The signaling combinations received by the machine are applied to a selecting mechanism identical in appearance to that used on the typing unit. The rangefinder and selector cam-clutch assembly are shown in figure 140. The start pulse of each code combination causes the selector-magnet armature to trip the selecting cam-clutch as previously discussed. Driven by the main shaft, shown in figure 141, the

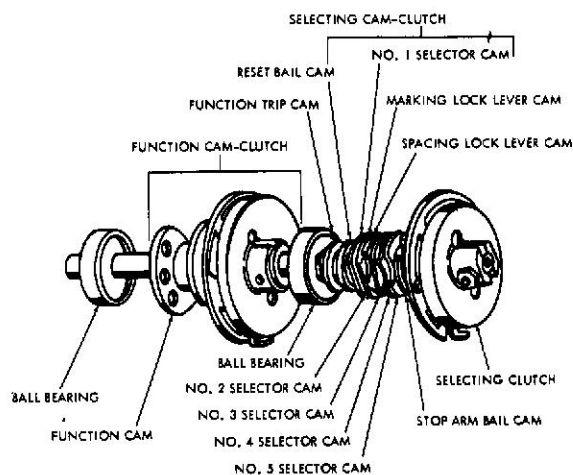

Figure 141. Typing reperforator main shaft.

cam-clutch begins its cycle, which will convert the electrical code combination into the corresponding mechanical arrangements. Near the end of each selecting cycle, the selecting cam-clutch trips the function cam-clutch and permits the punch slides of the perforator to receive the combination from the selector. The selector cam-clutch is then disengaged by the stop pulse and remains in the rest position until the next start pulse is received. The electrical input to this point corresponds to the mechanical keyboard input supplied to operate the typing reperforator.

26-16. **Selecting mechanism.** The selecting mechanism, made up primarily of the selector, shown in figure 140, the cam-clutch portion of the main shaft, shown in figure 141, and the selecting mechanism, shown in figure 142, translates the signaling code into mechanical arrangements which govern printing and perforating of the tape. We have already covered the operation of the selecting mechanism in our discussion of the typing unit. The selecting cam-clutch assemblies of both the typing unit and the reperforator are similar

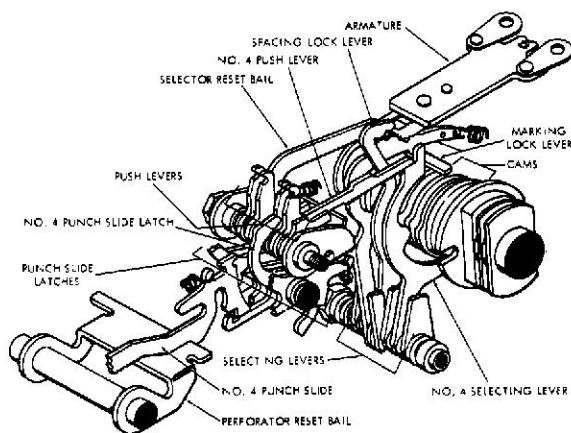

Figure 142. Selecting mechanism.

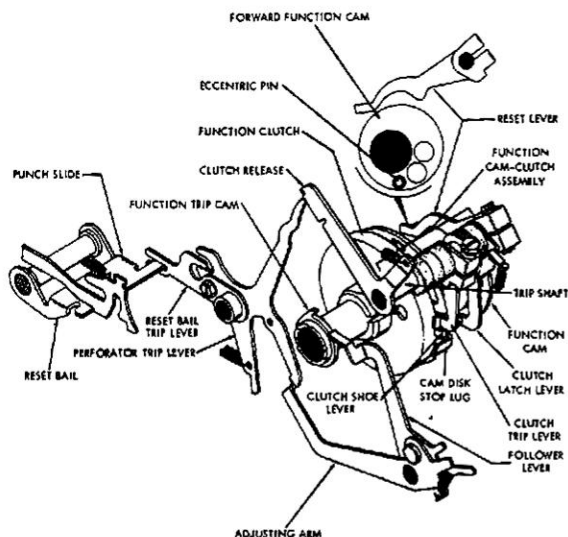

Figure 143. Function trip mechanism.

with the exception that the last cam on the reperforator cam-clutch assembly acts as a function clutch trip cam.

26-17. *Code reception.* When a selecting lever, shown in figure 142, responds to a marking impulse and rotates slightly in a clockwise direction, the associated push lever drops in front of the raised shoulder of the selecting lever. When the selecting lever is cammed counterclockwise to its normal position, the push lever moves to the left, as in figure 142. The moving push lever contacts the punch slide latch and causes it to rotate counterclockwise. This then releases the punch slide so that it can move to the left for a marking code pulse.

26-18. Just before the fifth push lever is selected, the function trip cam of the selector cam assembly, shown in figures 142 and 143, causes the reperforator reset bail to release the punch slides. By this time, the fifth code has been received and registered in the push lever. The unselected levers hold their associated slides to the right for spacing, while the selected latches permit their slides to move to the left under spring tension for marking. A little later on in our discussion, you will see how the reset bail returns the punch slides to their unselected position near the end of the function cycle. The latches, under spring tension, return to their unselected position when the selected push levers are repositioned at the beginning of the next cycle. With this in mind, let us now see how the unit develops the motion required for perforating and printing.

26-19. *Motion for Perforating and Printing.* We know that the machine can be geared to operate at speeds of 45.5 or 75 bauds. When the selector switch is in the T position, the keyboard typ-

ing reperforator can operate at a speed of 150 words per minute—if the operator is capable of typing at that speed.

26-20. Power and motion is distributed from the main shaft to the mechanisms concerned with perforating and printing by the function mechanism which is comprised of a cam-clutch (shown in fig. 141); a clutch trip assembly, which is shown in figure 143 with the main shaft cut away at the last cam of the selecting cam assembly; and a rocker bail mechanism which operates off the function cams on the main shaft. This mechanism is shown in detail in figure 144. Let us now see how these assemblies operate.

26-21. *Function cam-clutch and clutch trip assembly.* The trip assembly is shown in the unoperated condition in figure 143. The reperforator trip lever, shown in the center of figure 143, can be operated by both the mechanical input from the keyboard in the T mode of operation and by the electrical input when the selector switch is in the K-T position.

26-22. When you glance back at figure 139, you can see how the reperforator trip lever is operated through the linkage to the clutch trip bar in the keyboard. This is the method used in the T mode of operation. The reperforator trip lever can also be activated by the function trip cam, which is the last cam on the selector cam assembly of the main shaft. A received start pulse will cause the selector cams to rotate; and the function trip cam, through the follower lever and adjusting arm, trips the reperforator trip lever when the machine is conditioned for the K-T mode of operation.

26-23. The reset bail trip lever is attached to the reperforator trip lever, and it moves downward as the reperforator trip lever rotates counterclockwise. This lowers the reperforator reset bail, allowing the selected punch slides to move to the left for a marking code pulse. At the same time, the

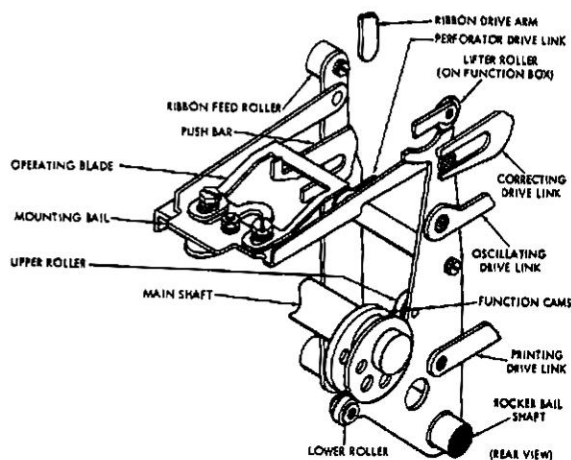

Figure 144. Rocker bail assembly.

upper arm of the perforator trip lever moves out of the way of the clutch release which falls against a downstop and, in doing so, rotates the trip shaft in a counterclockwise direction.

26-24. In the T mode of operation, the perforator trip lever latch in the keyboard lowers the perforator trip lever to return to a position where the upper arm of the trip lever is against the clutch release. In the K-T mode, the perforator trip lever latch is out of the way, allowing the perforator trip lever spring to return the trip lever against the clutch release.

26-25. When the trip shaft is rotated by the release, it moves the clutch trip lever out of engagement with the clutch shoe lever; and the clutch engages to begin the function cycle. About midway through the function cycle, the eccentric pin, shown on the forward function cam in figure 143, lifts the reset lever, which rotates the trip shaft clockwise. The clutch release rotates clockwise, allowing room for the upper arm of the perforator trip lever to move in under the clutch release. This also raises the reset bail. The eccentric pin then moves out from under the reset lever, and the clutch release is permitted to return to its unoperated position against the perforator trip lever. When the cam-clutch assembly completes its cycle, the clutch shoe lever strikes the clutch trip lever, and the clutch is disengaged.

26-26. *Rocker bail assembly.* The rocker bail assembly, shown in figure 144, distributes motion from the function cam-clutch to the following components:

- Perforator
- Function box
- Push bars of the type wheel positioning mechanism
- Oscillating assembly
- Corrector mechanism
- Printing mechanism
- Ribbon feed mechanism

26-27. The rocker bail is shown in the rest position in figure 144. With each function cycle, the two function cams, shown in the illustration, bear against rollers (upper and lower) and cause the bail, when viewed from the front of the machine, to rock to the left during the first part of the cycle and then back to the rest (or home) position during the latter part of the cycle.

26-28. *Transfer.* Near the end of each selecting cycle, the transfer mechanism, shown in figure 145, moves the input intelligence in the form of a mechanical arrangement from the punch slides, shown in figures 142 and 145, to the function box and positioning mechanisms. Each of the five punch slides has a linkage arrangement similar to that shown for the No. 4 punch slide in figure 145.

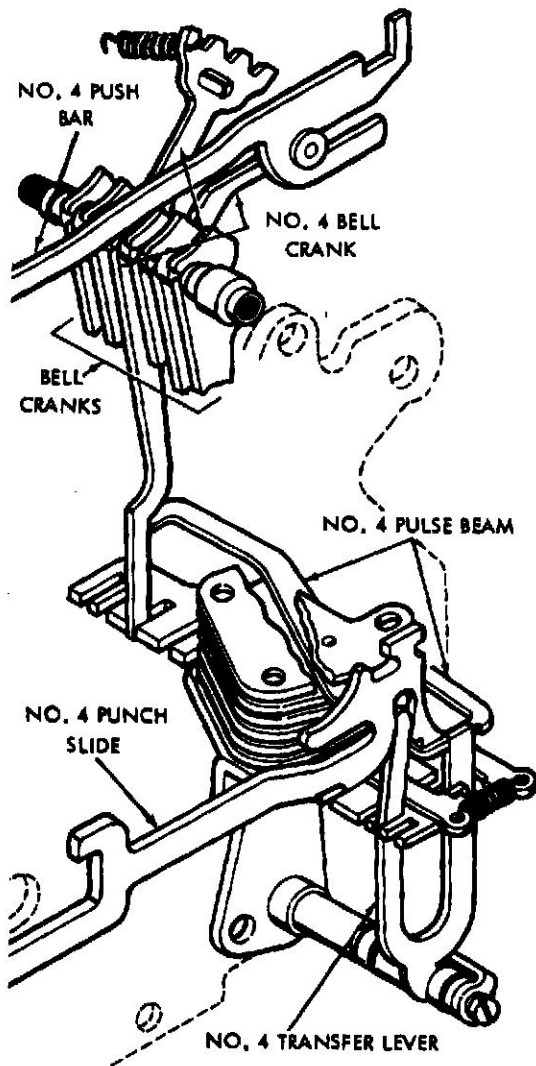

Figure 145. Transfer mechanism.

Each linkage consists of a transfer lever, a pulse beam, and a bell crank.

26-29. The linkages associated with the unselected punch slides (spacing) remain as shown in figure 145. However, the selected (marking) slides, in moving to the left, pivot the associated transfer lever which, through the pulse beam and bell crank, raises the attached push bars. The push bars control the positioning mechanism. In the period of the last half of the function cycle, the selected punch slides are moved back, carrying with them the transfer linkages and returning the linkages to their unselected position.

26-30. Slotted upper arms (like that shown on the No. 4 bell crank in fig. 145) extend up into the function box but are not used in the typing reperforator. An additional bell crank, not associated with a transfer linkage, is used for letters-figures shift.

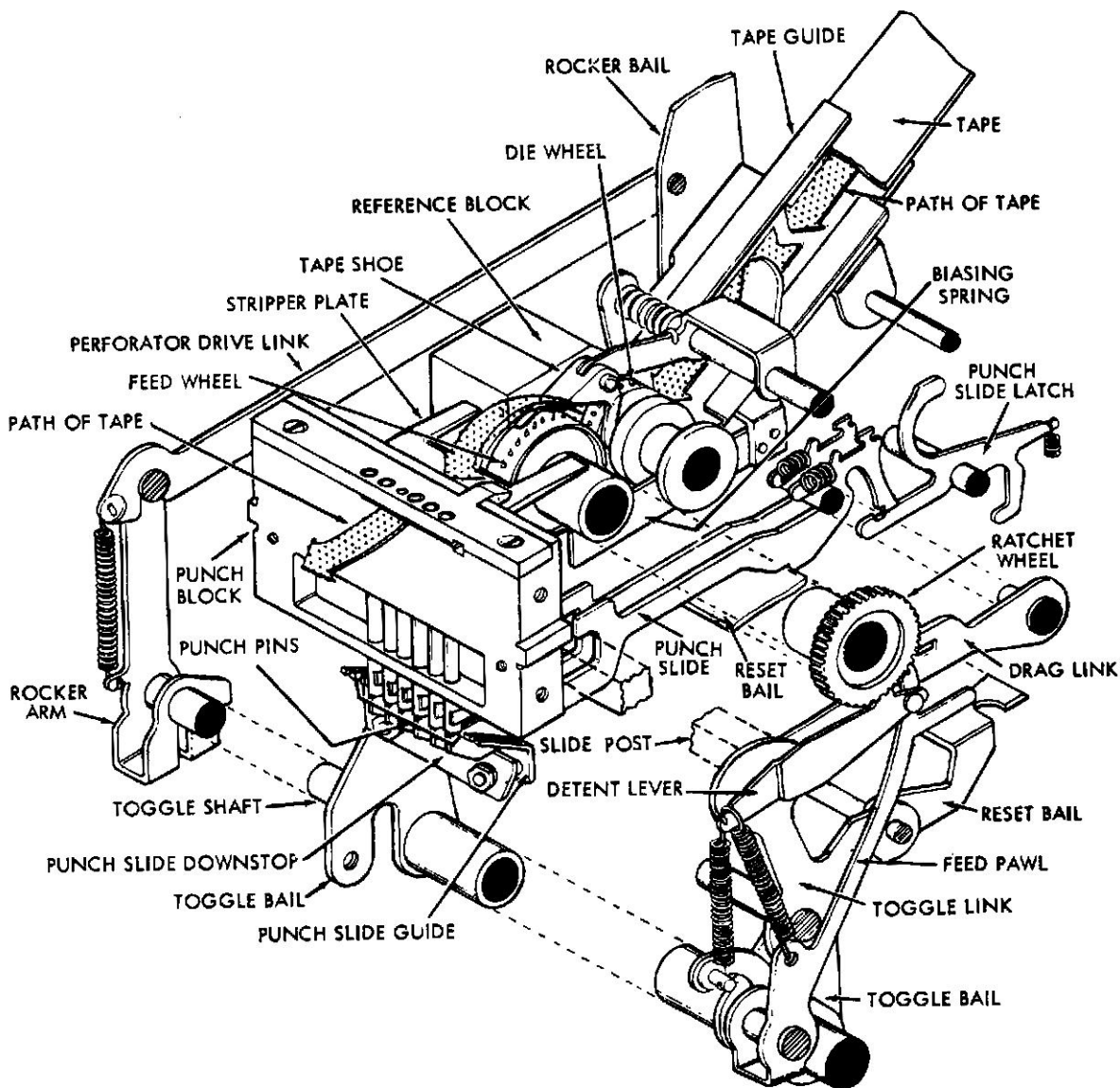

Figure 146. Perforating mechanism.

26-31. **Tape Perforating and Feeding.** The perforator mechanism punches feed holes, advances the tape, and perforates combinations of code holes corresponding to the code combinations received from the keyboard or the line. The intelligence is set up in the punch slides as previously described, which select the proper pins in the punch block assembly shown in figure 146. Motion from the rocker bail, located in the upper right section of the drawing, is distributed to the punch pins and the tape feeding components by a toggle bail assembly (lower portion of illustration). This assembly includes the toggle bail, a toggle shaft, a slide post, toggle links, drag links, and the punch slide reset bail.

26-32. **Perforating.** We have already discussed how, through the action of the perforator trip le-

ver, the reset bail is lowered, releasing the five punch slides. The selected slides move to the left, and the unselected slides are held to the right by their latches. In the selected position, a projection near the left end of each slide extends over the slide post which is attached to the left end of the drag link, as shown in figure 146. An additional punch slide, associated with the feed hole, is designed so that it is always in the selected position.

26-33. During the first part of the function cycle, the rocker bail moves to the left and, by means of the perforator drive link and rocker arm shown to the rear in figure 146, rotates the toggle shaft and bail counterclockwise. Toggle links attached to the front and rear of the bail lift the slide post and move the reset bail to the left. The selected slides are carried upward by the post and force

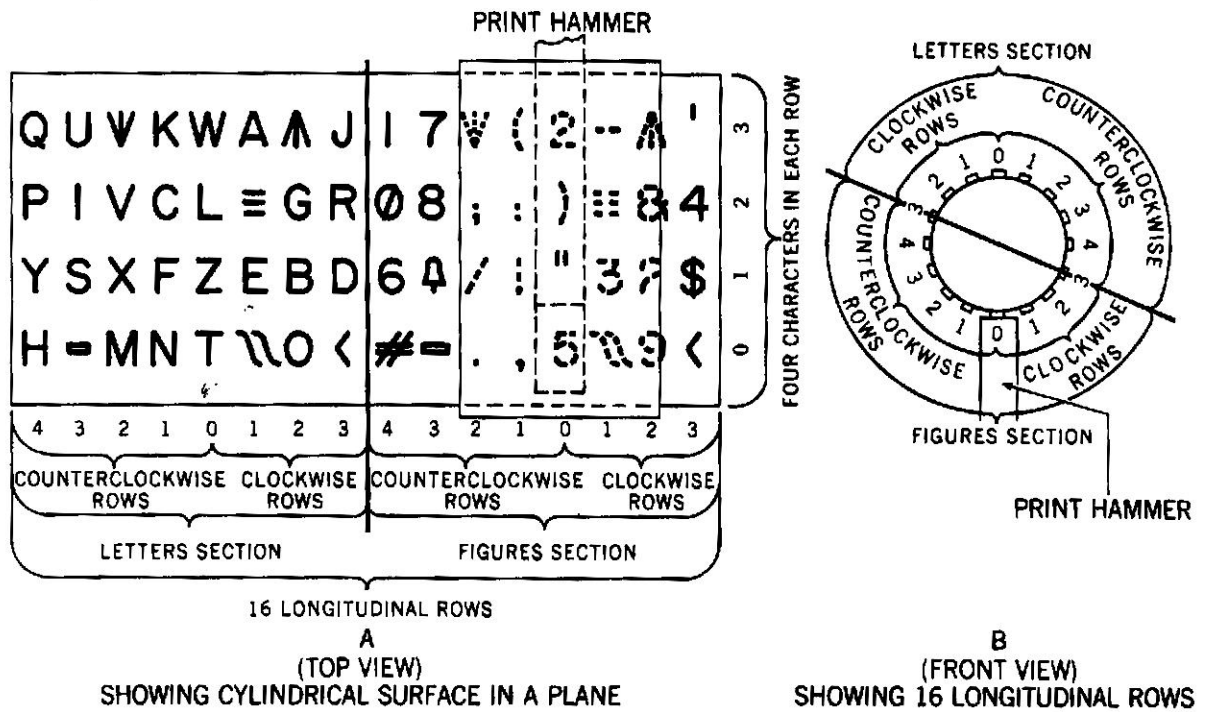

Figure 147. Type wheel character arrangement.

the associated pins through the tape. The slides pivot about the same point as the drag links, and so become part of the toggle bail assembly during the perforating stroke. Approximately midway through the function cycle, the function trip assembly lifts the reset bail so that it is in position to hold the punch slides to the right on the next cycle.

26-34. During the last half of the cycle, the toggle bail is rotated clockwise, pulling the slide post down and lowering the selected punch slides. The punch slides, which engage notches in their respective punch pins, pull the punches down below the tape. The toggle bail assembly and the selected punch pins move as a unit during the perforating stroke.

26-35. *Tape feed.* Tape feed is accomplished after perforation, during the last half of each function cycle. The tape is threaded down through a type guide and then up between a feed wheel and a die wheel as shown in figure 146. A feed pawl (lower right of illustration), driven by the toggle bail, acts upon the feed ratchet wheel and rotates the feed wheel. The feed wheel, by means of sharp pins and the holes in the die wheel, advances the tape one character space at a time. A detent with a roller that rides on the bottom of the ratchet wheel holds the feed wheel and tape in position during perforation. The tape is stripped from the feed wheel by a stripper plate upon which printing takes place, and then passes into the punch block where it is perforated. Of course, we know that perforation and printing occur at the

same time so that the printed character is always six spaces behind the corresponding set of perforations. Speaking of the printed character, let's see how typing is done on the typing reperforator.

26-36. *Typing.* The characters used for typing (letters, figures, and symbols representing various functions) are embossed on the cylindrical surface of the metal type wheel. The type wheel normally furnished with the typing reperforator will print standard communications symbols. During the function cycle, the rotary and axial positioning mechanism, having received the code combination from the transfer mechanism, positions the type wheel so that the character represented by the input code is selected. Following type wheel positioning, the correcting mechanism accurately aligns the selected character. The printing mechanism, by means of the printing hammer, then drives the tape and inked ribbon against the wheel and imprints the character. A ribbon feed mechanism advances the ribbon and reverses its direction of feed when one of the two ribbon spools becomes empty. Near the end of the function cycle, the axial positioning mechanism retracts the type wheel and ribbon guide so that the last printed character is visible. The letters or figures code combination sets up an arrangement in the transfer mechanism which permits the function box to operate and cause the rotary positioning mechanism to shift the type wheel through 180° of rotation.

26-37. *Type Wheel Positioning.* The type



wheel character arrangement is shown in figure 147. View A shows a top view of the cylinder rolled out into a flat plain. If you will count the rows, you will find 16 longitudinal rows, each of which is made up of four characters numbered 0 to 3 from front to rear. The surface is divided into two sections, a letters and a figures section, each containing eight rows, as shown in both A and B of figure 147. The fifth row counterclockwise from the division line in both sections is numbered 0, and there are four rows in one direction from 0, numbered 1 through 4 and designated as counterclockwise rows. Note that there are three rows from the 0, numbered 1 through 3 in the clockwise rows. The clockwise and counterclockwise designations refer to the direction of rotation needed for the wheel to position with the desired character at the bottom.

26-38. Each printing operation — excluding those needed for the letter-figures shift—begins and ends with the type wheel in the home (0-0) position of the section (letters or figures) containing the character which has been printed. This would be the number 5 in the figures section and the letter "T" in the letters section. Actually, inasmuch as the type wheel is retracted to show the last character printed, the 0-0 character is slightly to the rear; but for our discussion let us assume that it is at the point of contact (over the print hammer). During the printing operation, the axial and rotary positioning mechanism—transferring separate but coordinated motions to the type wheel—positions it so that the character to be printed is at the point of contact with the hammer at the time of printing. The rotary mechanism, which selects one of eight longitudinal rows, is controlled by the No. 3, 4, and 5 selecting elements of the code, and it revolves the wheel so that the proper row is selected. The axial mechanism, which is governed by the No. 1 and 2 code elements, moves the type wheel forward and rearward along its axis so as to select the proper character (0 through 3) in the row. The letters and figures shift consists of rotating the type wheel eight rows from the home position of the other section. This shifting requires a separate operation of the equipment and results in the printing of the letters or figures symbol.

26-39. As an illustration of the above, let us say that the type wheel is in the figures position, as shown in B of figure 147, and the numeral 5 is to be printed. In this case, there is no movement of the wheel for printing, as 5 (home position in figures) is already at the point of contact of the hammer. If, however, the letter "I" is to be printed, the code combination for letters must first be received to shift the type wheel eight rows counterclockwise to the letters section home posi-

tion (letter "T"). Then, during the next operation when the code combination for the letter "I" is received, the type wheel is rotated three rows counterclockwise and has an axial movement forward of two characters so that the "I" is rotated downward and is at the point of contact with the hammer. Printing takes place, and the type wheel is then returned to the letters home position.

26-40. **Rotary Movement.** The rotary positioning mechanism revolves the type wheel so that the row containing the character to be printed is down and aligned with the print hammer at the time of printing.

26-41. If you will study figure 148, you will see that the rotary positioning mechanism includes two eccentric assemblies, the left and the right. Each assembly includes a primary shaft, a section of which is formed into a pinion gear. These shafts (one for the left and one for the right eccentric assemblies) can best be seen in figure 149, which shows you a view of the push bars and the assemblies with the front plate removed. A secondary shaft, mounted in the primary and offset from its center, forms an eccentric referred to as the rear eccentric. A forward portion of the secondary shaft is also a pinion gear. A crankpin, mounted on its disklike forward surface, forms a secondary, or front eccentric. Each of the four pinion gears of the two eccentric assemblies is meshed with the gear surface of a push bar or bars.

26-42. The right eccentric assembly in figure 148 is controlled by two push bars, No. 3 and No. 5. If you will observe figure 149 closely, you will see that the No. 3 push bar operates on the front pinion gear, while the No. 5 push bar is meshed with the right rear pinion gear. Further observation of figure 149 will show you that the No. 3 bell crank must be lifted (marking pulse)

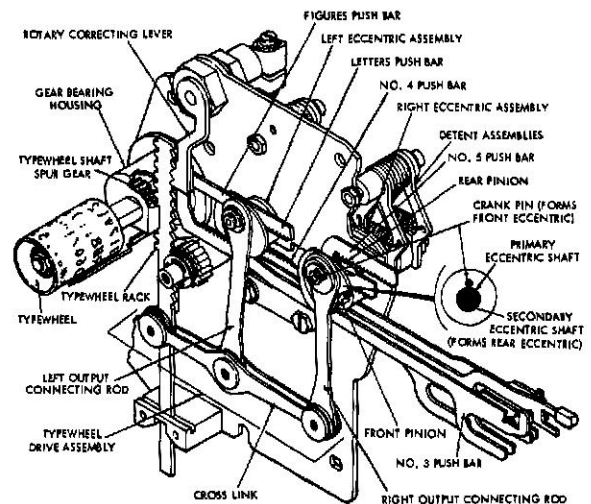

Figure 148. Rotary positioning mechanism.

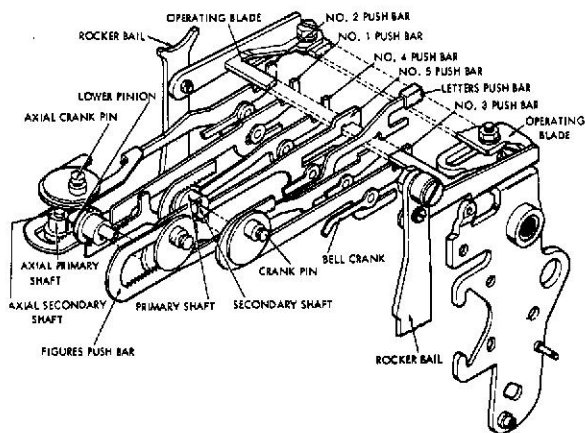

Figure 149. Push bars and eccentric assemblies.

to place it in the path of the operating blade when it moves to the right. The No. 5 push bar is constructed differently. It is placed *over* the operating blade and a marking impulse will raise it out of the path of the blade. Therefore you should realize that to turn the right rear pinion the No. 5 pulse must be spacing.

26-43. Now shift your attention to the left eccentric assembly. Note that *both* the letters and figures push bar operate on the left front pinion. A close examination will show you that the figures push bar engages the pinion gear at the bottom, while the letters push bar (directly behind the figures push bar) has teeth on the top and so engages the pinion gear at the top. You can readily understand why the figures push bar will rotate the left eccentric on figure 148 in one direction, while the letters push bar, when selected, will rotate the left eccentric in the opposite direction. Also note that the letters and figures push bar operate when the operating blade moves back to the right. The No. 4 push bar operates the left rear pinion gear and operates to the left on a mark.

26-44. The eccentric assemblies are linked to the type wheel by a drive assembly, as shown in figure 148. The type wheel is secured to the front of the shaft, which is supported by a bearing housing mounted at the left rear of the front plate. A spur gear, which meshes with the vertical type wheel rack, rides on the squared shaft in a bearing housing. The shaft is free to move in and out in the housing and through the squared hole in the spur gear. The squared shape of the shaft and the matching hole in the gear insures its rotation when the gear rotates in response to the vertical movement of the type wheel rack. Of course, you can see how the position of the left and right eccentrics control the vertical movement of the type wheel rack through the left and right output connecting rods and the cross link.

26-45. Let us concern ourselves with the operation of the No. 3, 4, and 5 push bars at this time, for they control the rotary position of the type wheel. The additional added effect of the letters or figures push bar will be discussed under the letters and figures shift.

26-46. When, in response to a mark impulse, the No. 3 or No. 4 push bar is lifted by its bell crank, the rocker bail operating blade engages the shoulder of a slot in the bar and moves it to the left during the first part of the function cycle. The bar, by means of its rack of teeth and the mating pinion gear in the eccentric assembly, rotates the associated eccentric one-half revolution, where it is locked in position by a detent assembly while printing takes place. When the bail rocks back to the right, it returns the bars and eccentrics to their home positions, where the eccentrics are again detented. The same procedure occurs when the No. 5 push bar is selected; however, as previously stated, the No. 5 push bar is selected when the fifth code pulse is spacing, not marking.

26-47. *Clockwise rotation.* Let's tackle the movement of the left eccentric first in response to any code combination, other than a letters-figures shift. When the No. 4 push bar is selected, it rotates the left rear eccentric 180° to where it is down. This causes the left front eccentric, together with the letters and figures push bars and the left output connecting rod, to move downward. The cross link is not pivoting at its connection to the right output connecting rod. This moves the left end of the cross link and the connected type wheel rack downward, imparting a clockwise turning to the type wheel. Under the influence of the No. 4 push bar alone, the type wheel will turn two rows clockwise from the home position.

26-48. The right rear eccentric operates in a similar manner; however, its home position is down. When the No. 5 push bar is selected (a spacing pulse) for a code combination, the movement of the push bar rotates the right rear eccentric 180°. This lifts the front of the right eccentric assembly on figure 148, the No. 3 push bar, and the right output connecting rod upward. Notice that now the cross link is pivoting on the left output connecting rod. Because the pivot point is in the middle of the cross link, the downward motion of the type wheel rack is one-half of the movement caused by the left rear eccentric. The type wheel, under the influence of the No. 5 push bar, will move one row clockwise.

26-49. If a code combination called for the fourth pulse to be marking and the fifth pulse spacing, the movements of both eccentrics, as just described, *combine* to rotate the type wheel three rows in a clockwise direction. This gives us all clockwise positions of the type wheel. Let us

now see how counterclockwise positioning is obtained.

26-50. *Counterclockwise rotation.* The No. 3 push bar, when selected alone (No. 4 and No. 5 not selected), develops the maximum counterclockwise rotation of the type wheel. When the No. 3 push bar is selected, it rotates the right front part of the right eccentric downward. The right front eccentric is on the primary eccentric shaft (as shown at the right in fig. 148). This rotation of the right crankpin results in the upward movement of the type rack, and the type wheel rotates four rows counterclockwise.

26-51. How do we get to the third row counterclockwise? Well, it takes a combination of counterclockwise and clockwise rotations. Let us say that the code combination for space (three marking) has been received. We know that the No. 3 and the No. 5 push bars will be selected and moved to the left. The movement of the No. 5 push bar, as already explained, causes an upward movement which should result in a one-row clockwise rotation of the type wheel. However, at the same time, the No. 3 push bar is rotating the front portion of the right eccentric downward, which should result in a four-row counterclockwise rotation. With a four-row counterclockwise movement and a one-row clockwise movement occurring at the same time, the combined reaction of the type wheel is a three-row counterclockwise rotation of the type wheel. A two-row counterclockwise rotation is the result when push bars No. 3 and No. 4 are selected, like when the letter "M" is received. A one-row counterclockwise rotation is the net result when all three push bars (3, 4, and 5) are selected—four counterclockwise movements and three clockwise movements result in one counterclockwise movement of the type wheel. Of course, if none of the three push bars are selected—say that the code combination received is for the letter "T" where the third and fourth pulses are spacing and the fifth is marking—there is no movement of the eccentrics and so consequently no rotation of the type wheel. The wheel remains on the zero, or home, row. In all of our discussion so far we have been interested in rotating the type wheel in either a clockwise or counterclockwise direction; yet, when we look at figure 147, we see that we must be able to move the type wheel outward to any one of four different characters in each row.

26-52. **Axial Movement.** The function of the axial positioning mechanism is to position the type wheel so that the proper character in the selected row is aligned above the print hammer at the time of printing, and to retract the type wheel and ribbon guide at the end of the function cycle so that the last typed character is visible. The axial positioning mechanism can be seen at the

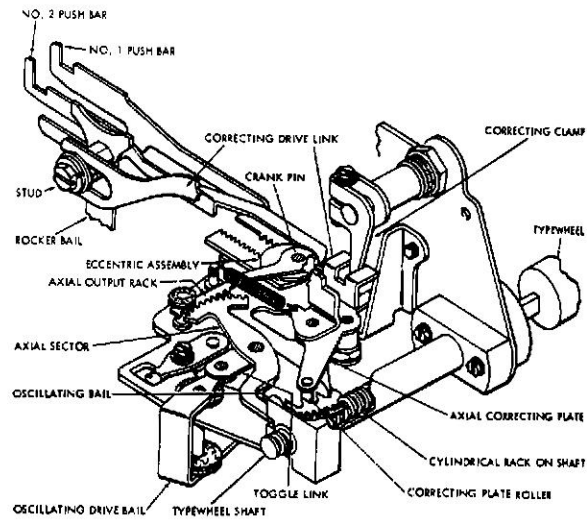

Figure 150. Axial positioning mechanism.

left rear portion of figure 149 and also in the rear view shown in figure 150. The components are mounted on an axial bracket supported by the frame and the front plate and include an eccentric assembly similar to the right eccentric assembly discussed in the paragraphs on rotary positioning. The lower eccentric is driven by the No. 1 push bar which, when selected by a marking code pulse, moves the upper portion of the eccentric. The axial output rack, shown in figure 150, then moves to the rear. The axial sector rotates counterclockwise, as viewed from the top rear, which moves the cylindrical rack on the type wheel shaft, the shaft itself, and the type wheel out from the home position one unit towards the front.

26-53. The No. 2 push bar, when selected, causes the upper portion of the axial eccentric assembly to rotate in such a manner as to move the output rack two spaces to the rear, which results in the type wheel moving out from the home position two units towards the front. When both the No. 1 and the No. 2 push bars have been selected (the letter "Q" is an example), movement of both push bars results in three axial units of movement. Of course, if neither one is selected (as for the letter "H"), there will be no axial movement of the type wheel other than that which results from the oscillating mechanism shown in the foreground of figure 150. This moves the wheel and the ribbon back each time so that the printed character can be viewed.

26-54. **Alignment Correction.** After the type wheel has been positioned by the rotary and axial positioning mechanisms, the selected character is more accurately aligned for printing by the correcting mechanism, which corrects any play and backlash in the positioning linkages.

26-55. *Rotary correction.* During each function cycle, the rocker bail transfers motion through a correcting drive link to a correcting clamp and shaft, shown at the top of figure 150. The shaft pivots a rotary correcting lever, shown in the upper center section of figure 148. Note that the end of the correcting lever is notched to engage a tooth on the type wheel rack. There is a tooth in the rack for each row of characters (16 in all), and they are so correlated with the type wheel that when a tooth is engaged by the corrector, the selected row is accurately aligned with the print hammer.

26-56. *Axial correction.* Axial correction, which is accomplished simultaneously, is similar to rotary correction. The drive link shown on figure 150 rotates an axial correcting plate counterclockwise, as viewed from the top rear of the unit. A roller mounted on the plate engages a notch in the axial sector, as shown on the illustration. Thus, the type wheel is accurately aligned in both the rotary and axial positions just before printing takes place. After printing has taken place and the unit is in the latter portion of the function cycle, a correcting drive link spring returns the correcting mechanism to its home position.

26-57. Since the rocker bail is the source of motion for both the push bars, the positioning mechanisms, and the correcting mechanisms, timing is quite critical and corrections must take place late in the forward portion of the cycle. Corrections must be made at a point near enough to the extreme leftward movement of the bail that it does not interfere with the movement of the type wheel rack or axial sector. In addition, because the rocker bail controls the tripping of the print hammer, which also occurs very late in the bail's power stroke, it becomes necessary to use the time between the tripping of the hammer and striking of the paper to accomplish correction. The delay in actuating the correcting mechanism is effected by mounting the drive stud on the rocker bail to slide in an elongated slot in the correcting drive link during the early part of the cycle.

26-58. **Letters and Figures Shift.** The purpose of the letters-figures shift is to rotate the type wheel from the home (or zero row) position, as shown in figure 147, in one section to that of the other section. This is accomplished through a function box mechanism which is made up of a number of parts mounted on and between two plates located at the upper rear of the typing reperforator unit. Figure 151 is an exploded view of the function box taken from the rear of the unit. As the illustration and figure 148 show the mechanism in the letters position, let us first

discuss the shifting to the figures position before studying the letters shift.

26-59. *Figures shift.* When the unit is in the letters position and the figures code combination is received, the transfer mechanism sets up the figures arrangement in the bell cranks. As the rocker bail moves from its home position during the first part of the function cycle, the lifter roller, which is shown nearest to you in figure 151, is forced down into the semicircular camming surface by spring tension. As the lifter drops, it allows the letters and figures function blades to move down and, by means of the projections on their lower surface, feel for an unblocked opening in the slotted upper arms of the bell cranks. With the No. 3 bell crank (far left, near front plate in fig. 151) to spacing, the letters function blade is blocked and only the figures function blade is allowed to complete its downward movement.

26-60. In moving all the way down, the figures function blade encounters an extension on the figures arm assembly, which is just to the left of the rear plate of the function box. Pressure on this extension rotates the figures arm assembly counterclockwise, as viewed from the rear in the illustration. This also rotates the figures yield arm and yield arm extension in the same direction. This movement of the figures yield arm, away from the right side (in our illustration) of the upper extension of the letters-figures bell crank, allows the letters yield arm, which presses against the left side of the upper extension of the bell crank, to apply spring pressure. This pressure rotates the letters-figures bell crank clockwise. This lifts the letters and figures push bars so that the letters push bar, which is taken out of the path of the operating blade, while the figures push bar is placed into the path of the operating blade. The notched ends of the figures arm assembly and the letters arm assembly (close to the rear plate of the function box) lock together in a position to hold the figures yield arm extension away from the letters-figures bell crank and the letters yield arm against the bell crank when the lifter roller moves up and out of the camming surface of the rocker bail. This happens when the rocker bail completes its forward motion. Of course, the upward motion of the lifter carries both function blades away from the tops of the bell cranks.

26-61. You must always remember that many operations are occurring at the same time. For instance, while the letters-figures bell crank is being positioned by the function box mechanism, the No. 1, 2, and 4 push bars are selected and move to the left in figure 149. This, of course, activates the axial and rotary positioning components. Axial movement of the type wheel is

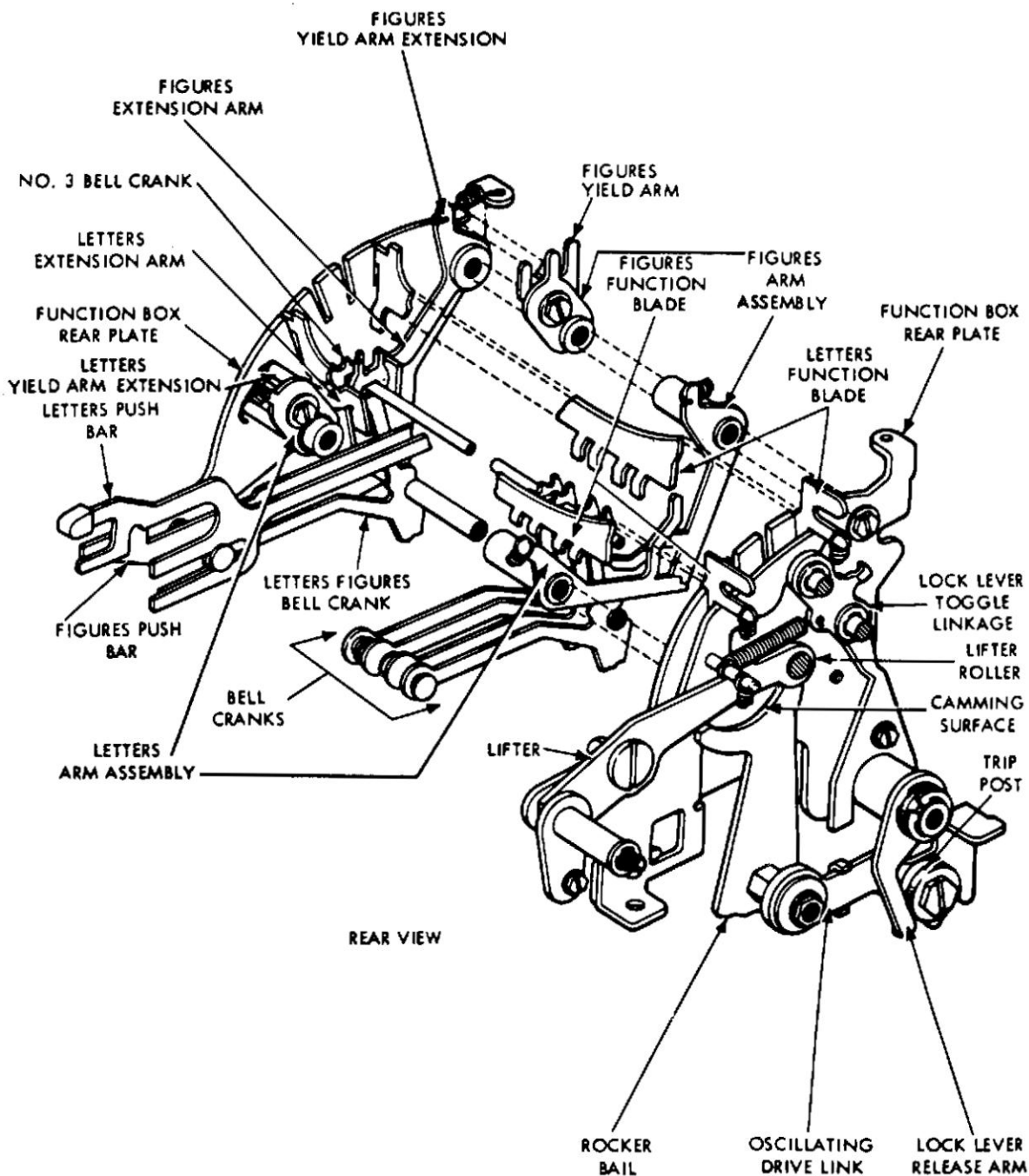

Figure 151. Function box.

three characters forward to the last character in the row, while the type wheel rotates two rows clockwise. This lines up the figures symbol with the print hammer and the symbol is printed as the rocker arm completes the power stroke. Note that the figures symbol printed is on the letters section of the type wheel, as the figures shift has not, as yet, occurred. The shifting of the type wheel occurs when the rocker bail operating blade is on the return stroke. It then encounters the shoulder

of the raised figures push bar and moves it to the right, as seen in figure 149. This rotates the left front pinion gear and eccentric. The letters push bar moves to the left (it operates on the same pinion gear as the figures push bar) and the eccentric turns from the up to the down position. This adds six clockwise steps of rotary movement to the type wheel. As the type wheel has already moved two steps clockwise for the figures combination, the wheel now rotates an additional

six steps to turn it around to the zero row in the figures section, as shown in figure 147.

26-62. *Letters shift.* In a manner similar to that described above, when the letters code combination is received, the letters function blade is not blocked and moves all the way down into engagement with the bell cranks. The letters arm assembly rotates the letters extension arm away from the letters-figures bell crank, and the figures extension arm rotates the letters-figures bell crank downward so that the letters push bar can be moved by the operating blade of the rocker arm on the return stroke. With the No. 1, 2, 3, and 4 push bars selected and operated to the left on figure 149, the axial movement is again to the last character in the row, while rotary motion (two clockwise and four counterclockwise) results in a two counterclockwise rotation. The letters character in the figures section of the type wheel is printed. The return stroke of the operating blade finds the letters push bar to the left and in the path of the blade. The letters push bar is now forced to the right as the free fingers push bar moves to the left. The left front eccentric rotates upward, imparting a six-row rotary movement of the type wheel in a counterclockwise direction. This, added to the two-row counterclockwise rotation caused by the letter code combination, turns the type wheel a total of eight rows counterclockwise to the zero row of the letters section of the wheel.

26-63. In both cases—that is, for either letters or figures shift—as the rocker bail returns to its home position during the last half of the cycle, a lock lever toggle linkage, shown in the right foreground of figure 151, prevents the lifter roller from following the camming surface of the rocker bail. The lifter holds the function blades up so that they do not drop onto the bell cranks.

As the bail nears its home position, the trip post, riding on the oscillating drive link, strikes a lock release arm which buckles the toggle linkage, permitting the lifter roller to again follow the bail camming surface on the next operation. Each operation of the lifter permits the function blades to move down and feel for an opening in the top of the bell cranks. However, except for the letters or figures shift operation, they are blocked by the center projection on the tops of the bell cranks.

26-64. *Printing.* After the type wheel has been positioned and corrected, the printing mechanism supplies the force which drives the paper and the ribbon against the selected character on the type wheel. It does this operation by means of a print hammer, which is mounted on a shaft supported by a bracket attached to the type wheel bearing housing. In its unoperated condition, as illustrated in figure 152, the hammer is held against the accelerator by a weak spring. The accelerator is mounted on the hammer and is retained by the printing latch in its upper position against the tension of a relatively strong spring.

26-65. The rocker bail, during the early part of the function cycle, moves the printing drive link to the right, as viewed in figure 152. This causes the pivot arm to rotate clockwise. The arm lowers the trip link which glides in an elongated slot. Near the end of the rocker bail's travel, the trip link pivots the printing latch which releases the accelerator. Under the spring tension, the accelerator snaps down and impels the hammer upward. The face of the hammer drives the paper tape and inked ribbon up against the type wheel and imprints the selected character on the tape. The accelerator does not drive the hammer through the complete stroke, but is stopped by a projection on the latch bracket. Inertia carries the hammer the rest of the way. As the rocker bail returns to the home position, it causes the trip link to move up, release the latch, and return the accelerator to the latched position.

26-66. *Ribbon Feed and Reverse.* The characters are typed in ink supplied by an inked ribbon which is held between the tape and the type wheel by the ribbon guide and advanced by the ribbon feed mechanism shown in figure 153. A portion of the components play a part in the ribbon reverse operation which occurs when a ribbon spool is almost empty.

26-67. *Ribbon feed.* As you can see in the illustration, the path of the ribbon is down to the left off the top of the right spool, under the right roller and towards the left through the pins of the rear reversing arm, through the ribbon guide, up through the pins on the front reversing arm, over the left roller, and down to the right on the bottom of the left ribbon spool.

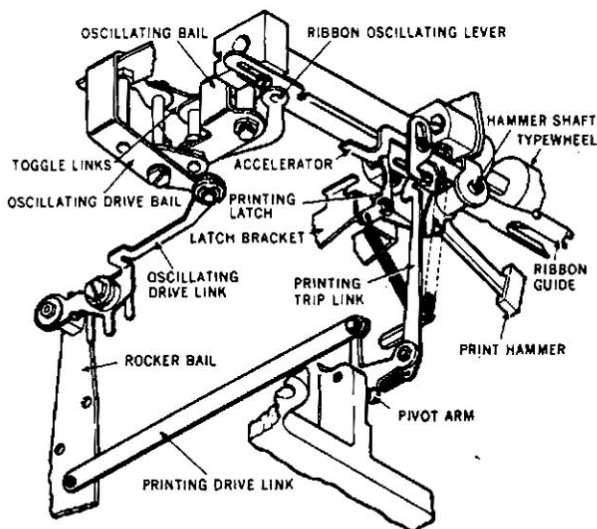

Figure 152. Printing mechanism.

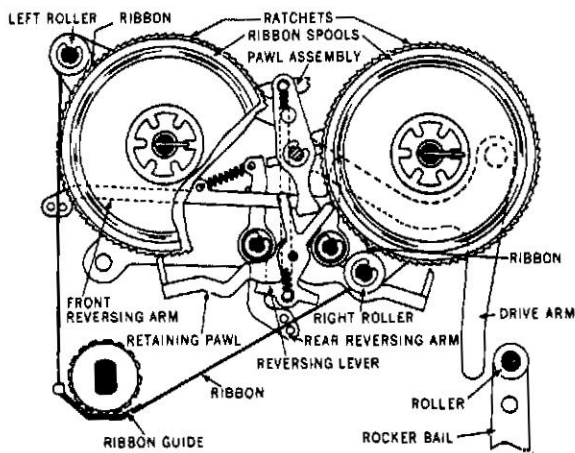

Figure 153. Ribbon feed mechanism.

26-68. During each function cycle, as the rocker bail nears the end of its left travel, a roller mounted on its forward arm pivots the ribbon feed drive arm clockwise. The drive arm lifts the ribbon feed pawl assembly, which advances the ribbon by rotating a ratchet and the attached ribbon spool one tooth. The retaining pawl holds the ratchet under spring tension, while the feed pawl, during the latter part of the function cycle, is lowered to engage the next tooth. Each operation causes the ribbon to advance in this manner until the ribbon feed mechanism is reversed.

26-69. *Ribbon reverse.* When a spool is almost empty, the eyelet in the ribbon encounters pins on the reversing arm. The tension applied to the ribbon, as it is wound on the spool, pivots the reversing arm. As the pawl assembly is lowered at the end of the next operation, an extension on the pawl assembly strikes the top of the reversing lever and the pawl is shifted to the other ratchet and ribbon spool. The pawl's rounded lower extension pivots a reversing lever, which shifts the retaining pawl so that it too engages the opposite ratchet. The ribbon will then feed in the opposite direction until again reversed.

### Review Exercises — Section 26

The following exercises are study aids. Write your answers in pencil in the space provided after each exercise. Use the blank page to record other notes on the chapter content. Immediately check your answers with the key at the end of the text. Do not submit your answers to ECI for grading.

1. What functions will the typing reperforator perform in response to line signals? Why? (26-2)

2. The operator of a Model 28 ASR set is using the keyboard to transmit a message to a distant station. The keyboard typing reperforator is recording a message; however, it is different from the one that the local operator is transmitting. Explain how is this possible? (26-4)

*Why the 3 different*

3. The code bar extensions do not move to the left when a key top is depressed. Is this a normal reaction of the machine? What does it indicate? (26-6,7)

*Yes, K or K T*

4. The operator of an ASR set informs you that the keyboard transmits perfectly and that the keyboard typing reperforator receives excellent copy from the line. However, it garbles when preparing tape locally. You test the machine by alternately depressing the R and Y key tops. The typing reperforator responds by punching and printing LF, Y; LF, Y. What is the trouble? Where is the most likely location of the trouble? Explain. (26-7,8)

*Not a problem with the machine*

5. With the keyboard selector switch in the T position, the code bar bail is pivoting clockwise. What operation is taking place? What component is directly responsible for this movement? What unit supplies the power to do this? (26-11-13)

*Reset of KB make rest*

6. The function trip cam on the typing reperforator main shaft is operating the follower arm. What code pulse is being received? What mechanical operation is about to take place? (26-15)

*It is operating on the 3rd code*

7. The perforator trip lever is rotating counterclockwise (when viewed from the front) while the function trip cam follower lever adjusting arm remains at rest. Is this possible? If so, when would it occur? (26-22-24)

*Yes, it is possible*