

CHAPTER 5 TROUBLESHOOTING

5-1. INTRODUCTION. This chapter provides information required to isolate a malfunction in compact page printer (CPP) teletypewriter sets to a misadjusted mechanism or a defective component. Troubleshooting is based on the results of operational tests described in paragraph 4-8d of Chapter 4. Wiring and schematic diagrams are presented at the end of this chapter for use in troubleshooting.

5-2. TROUBLESHOOTING PROCEDURES. Troubleshooting procedures for high and low-level CPP teletypewriter equipment are provided in paragraphs 5-2.1 and 5-2.2. The high-level procedures contained in paragraph 5-2.1, are also applicable to low-level equipment. The procedures contained in paragraph 5-2.2 are applicable to low-level equipment only.

5-2.1 HIGH-LEVEL TROUBLESHOOTING PROCEDURES. The following paragraphs provide procedures for use in troubleshooting high-level CPP teletypewriter equipment.

a. Troubleshooting Index. The troubleshooting index, table 5-1, contains the items referenced in tables 4-5 and 4-6, operational test procedures. If an abnormal indication is encountered, the technician is directed to a fault isolation paragraph describing remedies for symptoms related to the abnormal test results.

b. Lamp and Fuse Index. Table 5-2 provides a list of

lamps and fuses used in the high level CPP teletypewriter sets. The above active components constitute the most probable cause of failure.

c. Fault Isolation Procedures. The following paragraphs provide fault isolation procedures referenced in table 5-1.

(1) If unequal spacing between characters is observed, proceed as follows:

(a) Check horizontal positioning drive linkage adjustment (paragraph 6-3.1e(5)) (earlier designs - paragraphs 6-7.1e(1), 6-7.1e(3)).

(b) Check reversing slide brackets adjustment (paragraph 6-3.1e(12)).

(c) If adjustments are required in both steps (1) and (2), check rocker shaft bracket eccentric stud adjustment (paragraph 6-3.1e(3)).

(2) If type is not clear, proceed as follows:

(a) Check ribbon.

(b) Check type box.

(c) Check printing track adjustment (paragraph 6-3.1f(12)).

(d) Check printing hammer stop bracket adjustment (paragraph 6-3.1f(2)) (earlier design - 6-7.1f(2)).

Table 5-1. Troubleshooting Index

Item	Test/Step	Symptom	Fault Isolation Paragraph
1	2/g	Low range span.	5-2.1c (20)
2	3/a (1)	Printing unequal vertically.	5-2.1c (3)
3	3/a (2)	Unequal spacing between characters.	5-2.1c (1)
4	3/a (3)	Unclear type.	5-2.1c (2)
5	3/a (4)	Garbled test pattern.	5-2.1c (4)
6	3/a (5)	Improper ribbon feed.	5-2.1c (5)
7	3/b,c	Improper ribbon reverse.	5-2.1c (6)
8	4/c thru h	Machine does not meet requirements for copying a distorted signal.	5-2.1c (20)
9	*2/e (2) **2/c (2)	Figures-letters shift inoperative.	5-2.1c (7)
10	*2/e (2) **2/c (2)	Letters-figures shift inoperative.	5-2.1c (8)
11	*2/e (3) **2/c (3)	Normal carriage return inoperative.	5-2.1c (17)
12	5/f	Signal bell inoperative.	5-2.1c (12)
13	*2/e (3) **2/c (3)	Normal line feed inoperative.	5-2.1c (13)
14	*5/h,j **5/f,h	Single/double line feed improper operation.	5-2.1c (14)
15	*5/l (1) thru (5) **5/j (1) thru (5)	Automatic carriage return-line feed inoperative.	5-2.1c (15)
16	*5/l (1) thru (5) **5/j (1) thru (5)	Automatic carriage return-line feed improper operation.	5-2.1c (16)

Table 5-1. Troubleshooting Index - Continued

Item	Test/Step	Symptom	Fault Isolation Paragraph
17	*5/m thru p **5/k thru n	Automatic line feed on selected carriage return inoperative.	5-2.1c(18)
18	6/a	Local carriage return function inoperative.	5-2.1c(8)
19	6/b	Local line feed function inoperative.	5-2.1c(9)
20	*5/m thru p **5/k thru n	Line feed blocking after carriage return inoperative.	5-2.1c(19)
21	*8/f,h **8/b,d	High percentage of distortion.	5-2.1c(21)
22	7	One or more keys hard to press.	5-2.1c(22)
		*Table 4-5 **Table 4-6	

Table 5-2. Lamp and Fuse Index

Qty	Name, Type, Part Number	Function, Location	Energizing Voltage
2	Lamps, Indandescent, 151982.	Copyright, cover.	5.5 VAC
1	Fuse, 4 Amp, Slo-Blo, 129919.	Electrical circuit protection, Keyboard motor circuit.	--
1	Fuse, 1 Amp, 115358.	Electrical circuit protection, Keyboard function and reset circuits.	--

(e) Check printing arm adjustment (paragraph 6-3.1f(1)) (earlier design - 6-7.1f(3)).

(3) If printing is unequal vertically, proceed as follows:

(a) Check left and right vertical positioning lever eccentric stud adjustments (paragraphs 6-3.1e(8) and 6-3.1e(13)).

(b) Check right and left vertical positioning lock lever adjustment (paragraph 6-3.1e(19)).

(c) If adjustments are required in step (1), check rocker bracket eccentric stud adjustment.

(4) If a garbled test message is typed, proceed as follows:

(a) Check range setting.

(b) Check selector magnet bracket adjustment (paragraph 6-3.1g(14)).

(c) Check selector armature spring adjustment (paragraphs 6-3.1g(13), 6-3.1g(15)) (low - level - 6-3.2a(2)).

(5) If ribbon does not feed properly, proceed as follows:

(a) Check ribbon feed lever bracket adjustment (paragraph 6-3.1f(13)).

(b) Check ribbon feed lever spring.

(6) If ribbon does not reverse properly, proceed as follows:

(a) Check ribbon reverse spur gear adjustment (paragraph 6-3.1f(20)) (earlier design - paragraph 6-7.1f(5)).

(b) Check ribbon reverse detent adjustment (paragraph 6-3.1f(18)) (earlier design - paragraph 6-7.1f(6)).

(7) If repeating characters are observed, proceed as follows:

(a) Check code bar clutch trip lever adjustment (paragraph 6-3.1d(5)).

(b) Check type box clutch trip lever adjustment (paragraph 6-3.1d(8)).

(8) If local carriage return function is inoperative, proceed as follows:

(a) Press LOC CR key; verify local carriage return function bail moves top to rear; if not, check train of parts (located on keyboard) from key to bail.

(b) Ensure bail is operating carriage return lever; if not, remount typing unit.

(9) If local line feed function is inoperative, proceed as follows:

(a) Press LOC LF key; verify local line feed trip key moves to rear; if not, check train of parts (located on keyboard) from key to trip link.

(b) Ensure trip link is operating clutch trip

lever; if not, remount typing unit.

(10) If figures-letters shift function is inoperative, proceed as follows:

(a) Set up code combination for letters (12345).

(b) Engage and rotate function clutch 180 degrees; observe the following:

1. Letters function lever should be top to rear; if not, check function bar through lever.

2. Right shift link breaker slide should be rotated clockwise over breaker slide bail; if not, check parts from function lever to breaker slide bail.

(c) Rotate main shaft 180 degrees while observing the following:

1. Right breaker slide bail moves shift link breaker slide up.

2. Breaker slide buckles right oscillating rail shift link.

3. Oscillating rail moves left until left oscillating rail shift link completely straightens.

(11) If letters-figures shift function is inoperative, proceed as follows:

(a) Set up code combination for figures (12-45).

(b) Engage and rotate function clutch 180 degrees; observe the following:

1. Figures function lever should be top to rear; if not, check function bar through lever.

2. Left shift link breaker slide should be rotated counterclockwise over breaker slide bail; if not, check parts from function lever to slide bail.

(c) Rotate main shaft 180 degrees while observing the following:

1. Left breaker slide bail moves shift link breaker slide up.

2. Breaker slid buckles left oscillating rail shift link.

3. Oscillating rail moves right until right oscillating rail shift link completely straightens.

(12) If signal bell is inoperative, proceed as follows:

(a) Place typing unit in figures.

(b) Set up code combination for S (1-3--).

(c) Engage and rotate function clutch 180 degrees; signal bell function lever should be top to rear; if not, check function bar through lever.

(d) If signal bell function lever is properly positioned, trouble is electrical. Refer to schematics and wiring diagrams at end of this chapter.

(13) If normal line feed function is inoperative, proceed as follows:

(a) Set up code combination for line feed (-2---).

(b) Engage and rotate function clutch 180 degrees.

(c) Rotate main shaft 180 degrees; observe the following:

1. Line feed function lever should be top to rear; if not, check function bar through lever.

2. Check that line feed function pawl stripper is down and in proper engagement with stripper bail.

3. Check that clutch trip lever is out of path of shoe lever; if not, check bottom of function lever through trip lever.

4. Line feed bars should be in engagement with spur gear; if not, check line feed bar bell crank spring.

5. Rotate main shaft while observing that one line feed bar moves to rear and up while other line feed bar is moving down and rotating spur gear.

(14) If single/double line feed operates improperly, proceed as follows:

(a) Set single/double line feed lever in position 1.

(b) Observe that stripper bail is rotated counterclockwise (top view) in engagement with slot in line feed function pawl stripper; if not, check parts between lever

and bail and stripper bail spring.

(c) Set single/double line feed lever in position 2.

(d) Observe that stripper bail is rotated clockwise (top view) out of engagement with slot in line feed function pawl stripper; if not, check parts between lever and bail.

(15) If automatic carriage return line feed is inoperative, proceed as follows:

(a) Rotate spacing drum clockwise while observing the following:

1. Lug on spacing drum rear stop spring should strike and rotate automatic carriage return-line feed bell crank clockwise; if not, check for broken or bent lug or bell crank; check right margin adjustment (paragraph 6-3.1c(3), 6-3.1h(15), 6-3.1h(17)) (earlier design - paragraph 6-7.1h(7)).

2. The 0 (zero) code bar should move right; if not, check engagement of bell crank with code bar.

(b) Engage and rotate function clutch 180 degrees; observe the following:

1. Automatic carriage return and automatic line feed function levers should be top to rear; if not, check function bar through levers.

2. Normal line feed function lever should be top to rear; if not, check

tab on automatic line feed function pawl.

(c) Check engagement of bottom of automatic carriage return and normal line feed function levers with respective slide arms.

(16) If automatic carriage return-line feed function operates improperly, proceed as follows:

(a) If carriage does not return when 74th character is printed, check right margin adjustment (paragraphs 6-3.1c(3), 6-3.1h(15), 6-3.1h(17)) (earlier design - paragraph 6-7.1h(7)).

(b) If 75th character is not printed in center of page, increase tension on carriage return spring to move it to left, or decrease tension to move it to right.

(c) If carriage return spring tension was adjusted in step (2) above, readjust dash-pot vent screw (paragraph 6-3.1h(10)).

(d) If 76th and 77th characters are not positioned under 1st and 2nd, respectively, proceed as follows:

1. Check dash-pot vent screw adjustment (paragraph 6-3.1h(10)).

2. Check left margin adjustment (paragraphs 6-3.1c(1), 6-3.1h(2)) (earlier design - paragraph 6-7.1h(2)).

(17) If normal carriage return is inoperative, proceed as follows:

(a) Set up code combination for carriage return (---4-).

(b) Engage and rotate function clutch 180 degrees, observe the following:

1. Carriage return function lever should be top to rear; if not, check function bar through lever.

2. Carriage return feed pawl release link should be rotated counterclockwise holding feed pawls out of engagement with spacing drum, if not, check bottom of function lever through release link including carriage return lever adjustment (paragraph 6-3.1h(7)).

3. Carriage should be to left; if not, check for bind in spacing drum, draw-wire rope, carriage return spring drum, and printing and type-box carriages. Check tension on carriage return spring.

(18) If automatic line feed on selected carriage return function is inoperative, proceed as follows:

(a) Set up code combination for carriage return (---4-).

(b) Engage and rotate function clutch 180 degrees; observe the following:

1. Line feed on carriage return function lever should be top to rear; if not, check function bar through lever.

2. Check engagement of bottom of function lever with slide arm.

(19) If line feed blocking after carriage return function is inoperative, proceed as follows:

(a) Set up code combination for carriage return (---4-).

(b) Engage and rotate function clutch 180 degrees; observe the following:

1. Line feed on carriage return blocking function lever should be top to rear; if not, check function bar through lever.

2. Blocking slide should be to right with extensions in front of function bars in slots 39 and 40; if not, check top of function lever through blocking slide.

(c) Disengage function clutch.

(d) Set up code combination for line feed (-2---).

(e) Engage and rotate function clutch 180 degrees; observe the following:

1. Blocking function lever should be top to rear; if not, check blocking function lever latch.

2. Universal number 1 function lever should be top to rear; if not, check function bar through lever.

(f) Repeat steps (3) through (5); observe the following:

1. Universal number 1 and 2 function levers should be top to rear; if number 2 is not to rear, check function bar through lever.

2. Blocking slide should be to left; if not, check blocking function lever latch through blocking slide and shift plate post spring.

(20) If difference between range settings (range span) is too low or machine does not meet requirements for copying a distorted signal, proceed as follows:

(a) Check selector armature adjustment (paragraph 6-3.1g(10)) (low level - paragraph 6-3.2a(1)) (earlier design - paragraph 6-7.1g(4)).

(b) Check selector magnet bracket adjustment (paragraph 6-3.1g(14)).

(c) Check selector magnet bracket vertical adjustment (paragraph 6-3.1g(14)).

(d) Check for wear on armature extension, marking and spacing lock lever, and spring tensions.

(e) Check that range spans are centered on scale; if not, increase or decrease tension on selector armature spring to raise or lower range span.

(21) If percentage of distortion is too high, check keyboard shutter window gap

adjustment (low-level - paragraph 6-4.2a(1)).

(22) If one or more keys are hard to press, proceed as follows:

(a) Remove keyboard transmitter top plate.

(b) Check that keylevers are in proper slots.

(c) Check that keylevers are properly seated in slots.

d. Maintenance Schematic and Wiring Diagrams. Schematic and wiring diagrams are provided at the end of this chapter as aids to troubleshooting and maintenance of the teletypewriter sets. Figures 5-1 and 5-2 are schematic diagrams for high-level ac and dc circuits. Wiring diagrams for the high-level basic component assemblies are shown in figures 5-3 through 5-7. An index of the schematic and wiring diagrams for high-level equipment is provided in table 5-3.

5-2.2 LOW-LEVEL TROUBLESHOOTING PROCEDURES. The following paragraphs provide troubleshooting procedures for checking some of the difficulties that may be encountered in the operation of electrical service assemblies (ESAs) and their associated components. For troubleshooting mechanical failures refer to the high-level equipment troubleshooting procedures in paragraph 5-2.1, which are also applicable to low-level equipment.

a. Wiring and Schematic Diagrams. Wiring and schematic diagrams for use in troubleshooting low-level

equipment are shown in figures 5-8 through 5-29 at the end of this chapter. An index of these diagrams is provided in table 5-4.

b. Lamp, Photocell, Fuse, and Semiconductor Indexes. Refer to table 5-2 for a list of lamps and fuses used in both high-level and low-level teletypewriter sets. Table 5-5 lists additional lamps, photocells, fuses, and semiconductors found in low-level assemblies. These active components are identified because they constitute the most probable cause of failure.

c. ESA General Troubleshooting Instructions. The following paragraphs provide general instructions for use when troubleshooting CPP ESAs.

(1) Since the ESA encloses and is dependent on other component circuits for its operation, the field troubleshooting and repair for these components also are included in the procedures. Refer to the applicable wiring diagrams at the end of this chapter which are referenced in table 5-4, for circuit tracing and identification of components. The diagrams are identified with their associated assemblies in the equipment matrix provided in table 1-4 of Chapter 1, which also indicates the figure number.

(2) Before attempting to repair a power supply fault, the technician should familiarize himself with the power supply card and ESA wiring. Refer to the circuit description in Chapter 3. Refer also to the wiring diagrams for each teletypewriter set as identified in table 1-4 of Chapter 1. The wiring diagrams

Table 5-3. Index of High-Level Schematic and Wiring Diagrams for Troubleshooting

Figure	Diagram No.	Title	Page
5-1		AC Power and Control Circuits	5-11
5-2		DC (Signal) Circuits	5-13
5-3	5978 WD	Wiring Diagram; Model 28 CPP Covers LPC400 (KSR) and LPC402 (RO)	5-17
5-4	5976 WD	Wiring Diagram; Model 28 CPP KSF Keyboard Base LLK2	5-19
5-5		Wiring Diagram; Model 28 CPP RO Base LLB	5-21
5-6	3214 WD	Wiring Diagram; Model 28 CPP KSF and RO Typing Unit LP111	5-23
5-7	2900 WD	Wiring Diagram; Model 28 CPP Motor Units LMU37 and LMU51	5-25

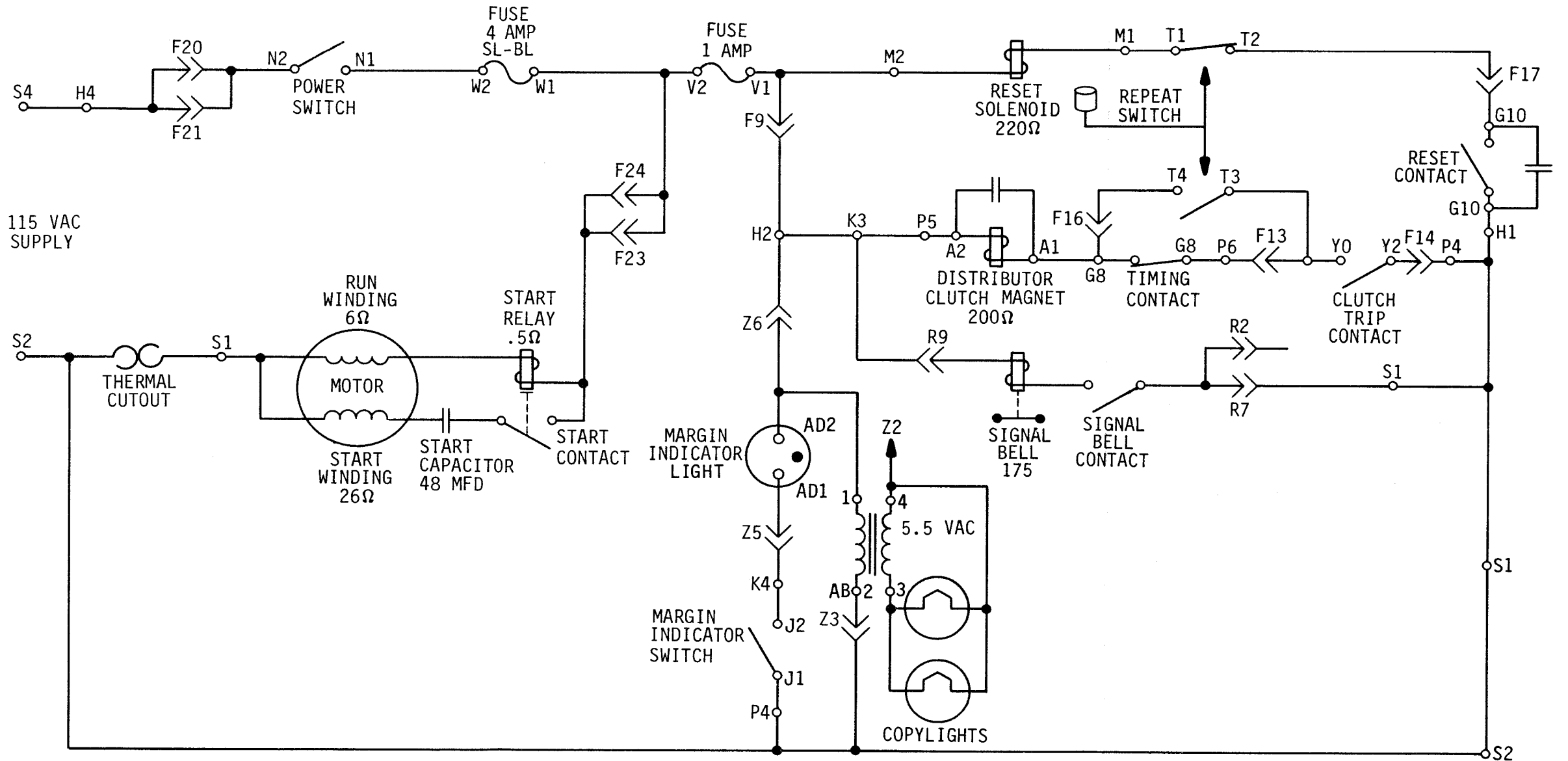

Figure 5-1. AC Power and Control Circuits

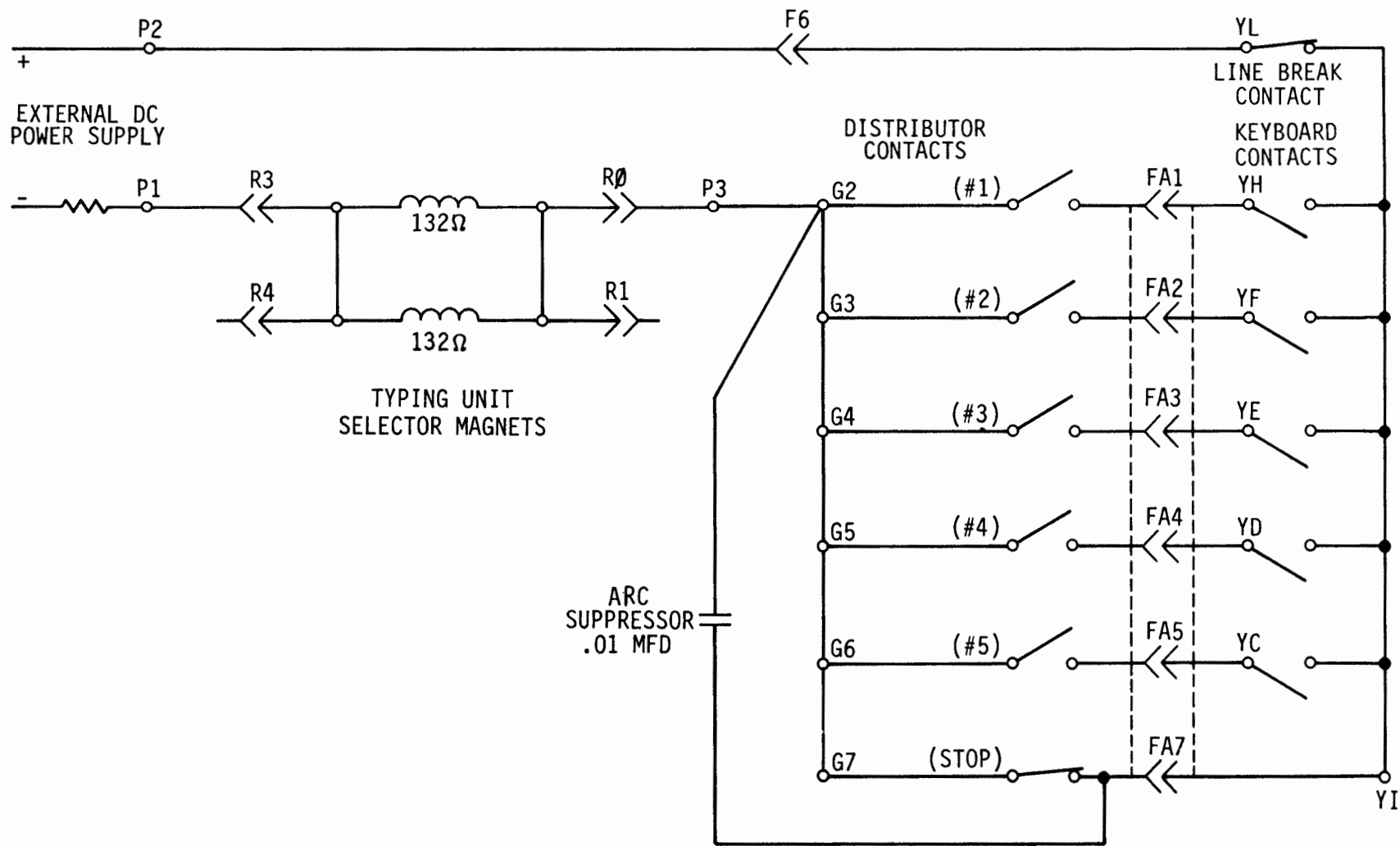

Figure 5-2. DC (Signal) Circuits

Table 5-4. Index of Low-Level Schematic and Wiring Diagrams for Troubleshooting

Figure	Diagram No.	Title	Page
5-7	2900 WD	Wiring Diagram; Model 28 CPP Motor Units LMU37 and LMU51	5-25
5-8	8728 WD	Wiring Diagram; Model 28 CPP KSP (Less Cover and Printer)	5-39
5-9	8729 WD	Schematic Diagram; Model 28 CPP KSP	5-41
5-10	8176 WD	Schematic Diagram; Model 28 CPP RO	5-43
5-11	8177 WD	Wiring Diagram; Model 28 CPP RO Cover LPC 402	5-45
5-12	8764 WD	Wiring Diagram; Model 28 CPP KSP Cover IPC 403	5-47
5-13	8137 WD (Sheet 1 of 3)	Wiring Diagram; Model 28 CPP RO ESA 321231 (Sheet 1 of 3)	5-49
	8137 WD (Sheet 2 of 3)	Wiring Diagram; Model 28 CPP RO ESA 321231 (Sheet 2 of 3)	5-51
	8137 WD (Sheet 3 of 3)	Wiring Diagram; Model 28 CPP RO ESA 321231 (Sheet 3 of 3)	5-53
5-14	8178 WD	Schematic Diagram; Model 28 CPP RO ESA 321231	5-55
5-15	321290	Assembly Drawing; Model 28 CPP KSR and RO ESA Power Supply Circuit Board Assembly with Heat Sink	5-57
5-16	321130 (Sheet 1 of 2)	Circuit Board Assembly; Model 28 CPP KSR and RO ESA Power Supply (47 - 53 VDC, 0.5 Amp Max) (Sheet 1 of 2)	5-59
	321130 (Sheet 2 of 2)	Circuit Board Assembly; Model 28 CPP KSR and RO ESA Power Supply (47 - 53 VDC, 0.5 Amp Max) (Sheet 2 of 2)	5-61

Table 5-4. Index of Low-Level Schematic and Wiring Diagrams for Troubleshooting - Continued

Figure	Diagram No.	Title	Page
5-17	323810	Circuit Board Assembly; Model 28 CPP KSR and RO ESA SMD with Signal Combiner	5-63
5-18	8143 WD	Schematic Diagram; Model 28 CPP KSR and RO ESA SMD with Signal Combiner, 323810	5-65
5-19	8724 WD (Sheet 1 of 4)	Wiring Diagram; Model 28 CPP KSR ESA 323120 (CMD) (Sheet 1 of 4)	5-67
	8724 WD (Sheet 2 of 4)	Wiring Diagram; Model 28 CPP KSR ESA 323120 (CMD) (Sheet 2 of 4)	5-69
	8724 WD (Sheet 3 of 4)	Wiring Diagram; Model 28 CPP KSR ESA 323120 (CMD) (Sheet 3 of 4)	5-71
	8724 WD (Sheet 4 of 4)	Wiring Diagram; Model 28 CPP KSR ESA 323120 (CMD) (Sheet 4 of 4)	5-73
5-20	8725 WD	Schematic Diagram; Model 28 CPP KSR ESA 323120 (CMD)	5-75
5-21	333069	Assembly Drawing; Model 28 CPP KSR ESA CMD Circuit Board Assembly with Heat Sink	5-77
5-22	333142	Schematic Diagram; Model 28 CPP KSR ESA CMD Circuit Board Assembly	5-79
5-23	8726 WD (Sheet 1 of 3)	Wiring Diagram; Model 28 CPP KSR FSA 323121 (SMD and LLK) (Sheet 1 of 3)	5-81
	8726 WD (Sheet 2 of 3)	Wiring Diagram; Model 28 CPP KSR ESA 323121 (SMD and LLK) (Sheet 2 of 3)	5-83
	8726 WD (Sheet 3 of 3)	Wiring Diagram; Model 28 CPP KSR ESA 323121 (SMD and LLK) (Sheet 3 of 3)	5-85
5-24	8727 WD	Schematic Diagram; Model 28 CPP KSR ESA 323121 (SMD and LLK)	5-87

Table 5-4. Index of Low-Level Schematic and Wiring Diagrams for Troubleshooting - Continued

Figure	Diagram No.	Title	Page
5-25	323130	Schematic Diagram; Model 28 CPP KSR ESA LLK Circuit Board Assembly	5-89
5-26	8179 WD	Wiring Diagram; Model 28 CPP RO Base LLB 5	5-91
5-27	8242 WD	Wiring Diagram; Model 28 CPP RO Typing Unit LP 139	5-93
5-28	8299 WD	Wiring Diagram; Model 28 CPP RO Typing Unit Selector Assembly 319204	5-95
5-29	8763 WD	Wiring Diagram; Model 28 CPP KSR Typing Unit LP 156	5-97

NO.	NOTES
1.	WIRING LEGEND: DISTANT TERMINATING AREA DISTANT TERMINATING DESIGNATION AB-4-BR WIRE COLOR CODE
2.	COLOR CODE: BK-BLACK R-RED BL-BLUE Y-YELLOW BR-BROWN G-GREEN O-ORANGE W-WHITE S-SLATE P-PURPLE
3.	ASSOCIATED WIRING DIAGRAM 5976W9 ACTUAL WIRING DIAGRAM LLK1 & LLK2 (FIGURE 5-4)
4.	INDICATES SPLICE SOLDER AND TAPE
5.	CONNECTOR VIEWED FROM SOLDER END.
6.	USE 155755 INSULATING SLEEVE ON THE CONNECTOR TERMINALS AFTER SOLDERING.
7.	THE 184856 NEON INDICATOR IS USED AS A MARGIN INDICATOR ON THE LPC 400 ONLY, ON THE LPC401 THIS LIGHT IS USED AS A POWER "ON" INDICATOR. BOTH COVER UNITS USE THE 198562 CABLE ASSEMBLY.
8.	SPLICE LEADS AB-3, AC-1 & AC-4 TAPE & TUCK & TIE AT THE "Z" CONN.
9.	EARLY VERSION COVERS UTILIZE ONE OF THE TRANSFORMER MOUNTING SCREWS FOR TERMINATING THE GROUND STRAP.

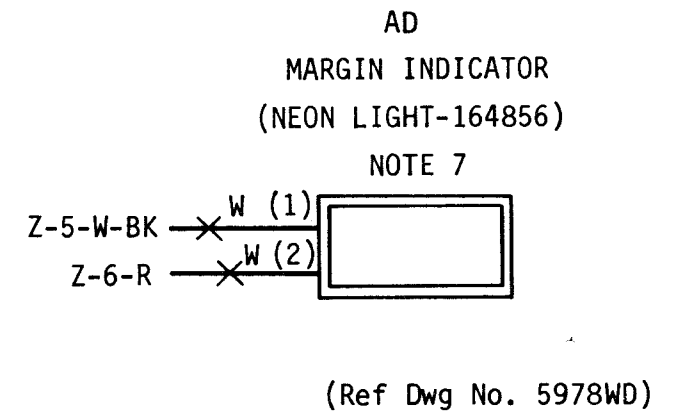
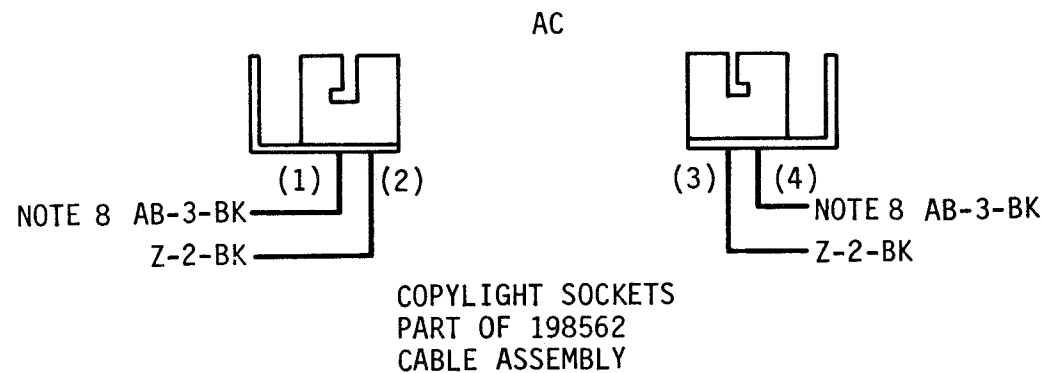
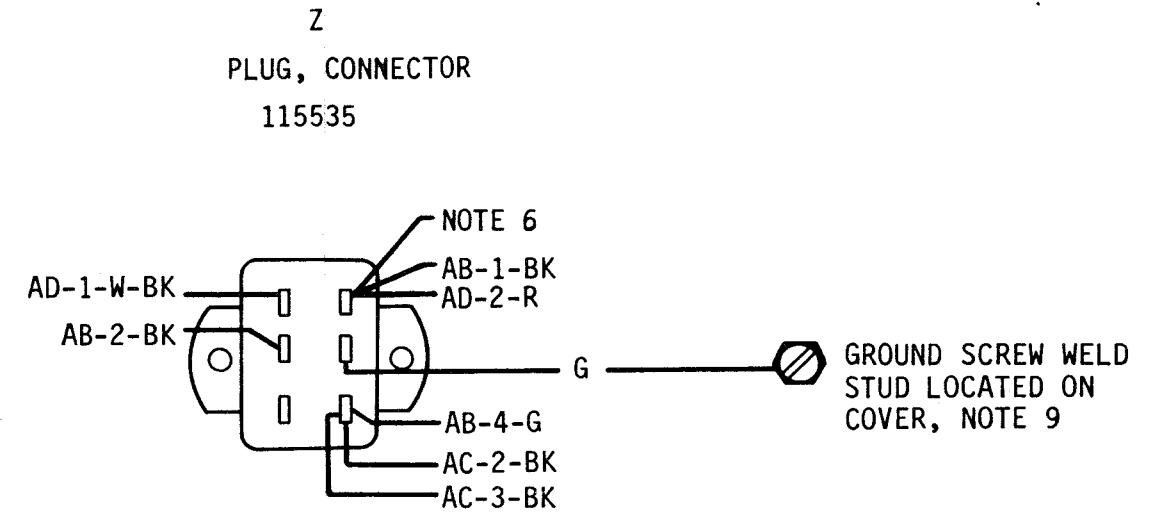
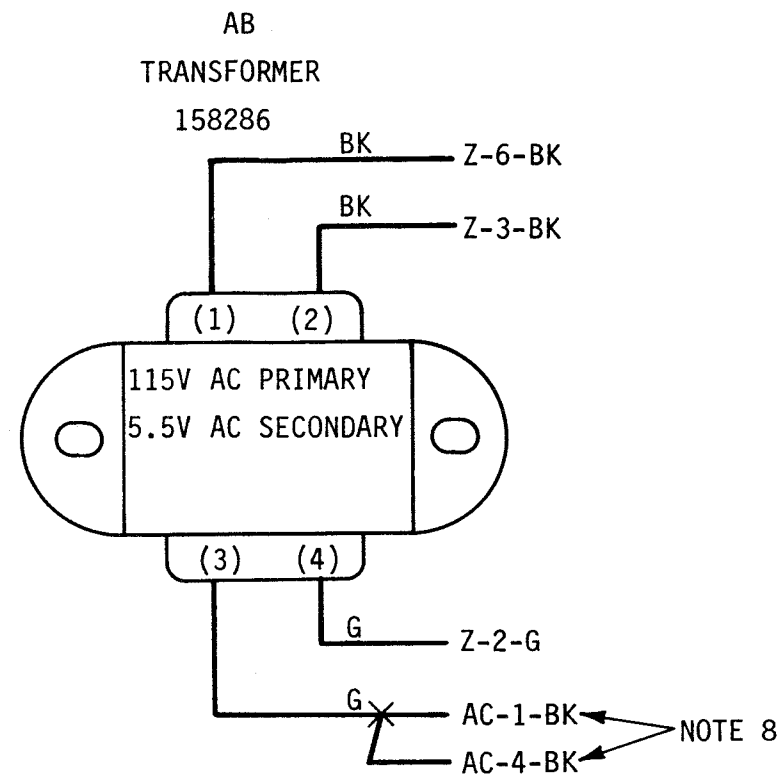

Figure 5-3. Wiring Diagram; Model 28 CPP Covers
 LPC400 (KSR) and LPC401 (RO)

- NOTES**
1. WIRING LEGEND
 DISTANT TERMINATING AREA
 DISTANT TERMINATING DESIGNATION
 G-9-W-P
 WIRE COLOR CODE
 2. COLOR CODE
 W - WHITE BL - BLUE
 BK - BLACK Y - YELLOW
 R - RED BR - BROWN
 G - GREEN P - PURPLE
 O - ORANGE S - SLATE
 W-BK - WHITE-BLACK
 W-R - WHITE-RED
 W-G - WHITE-GREEN
 W-O - WHITE-ORANGE
 W-BL - WHITE-BLUE
 W-Y - WHITE-YELLOW
 W-BR - WHITE-BROWN
 W-P - WHITE-PURPLE
 W-S - WHITE-SLATE
 R-BL - RED-BLUE
 W-P-BK - WHITE-PURPLE-BLACK
 W-BK-O - WHITE-BLACK-ORANGE
 3. CONNECTORS VIEWED FROM SOLDER END.
 4. B4551 TERMINAL STRAP
 5. * INDICATES 18 GA WIRE.
 6. WHEN TIME DELAY MOTOR STOP OPTION IS USED, CONNECT TO K TERMINAL BLOCK AS INDICATED ON SCHEMATIC WIRING DIAGRAM 5977WD.
 7. THIS UNIT IS WIRED FOR 115V AC OPERATION OF THE DISTRIBUTOR CLUTCH MAGNET. FOR SYNCHRONOUS PULSE OPERATION, REMOVE STRAPS P-4 TO S-2 AND P-6 TO K-3. EXTERNAL POWER (100 MILLI-AMPERES) TO BE FURNISHED BY CUSTOMER.
 8. GROUND SCREW LOCATED ON TERMINAL BLOCK MOUNTING BRACKET FOR CUSTOMERS TERMINAL GROUND CONNECTION.
 9. 103160 GROUND STRAP CONNECTED BETWEEN INNER AND OUTER PAN NEAR MOTOR; THIS APPLIES TO SETS WHOSE BASE SERIAL NO. IS ABOVE 447
 10. 151827 TERMINAL STRAP.
 11. NUMERALS IN PARENTHESES ARE NOT MARKED ON THE COMPONENTS BUT ARE SHOWN FOR PROPER TERMINAL ORIENTATION.
 12. SPARE TERMINAL BLOCK PROVIDED FOR CUSTOMER CONVENIENCE.
 13. FOR FULL DUPLEX OPERATION REMOVE G2 LEAD FROM P3 AND PLACE ON K51. TERMINAL, CONNECT INCOMING SIGNAL LINE TO P1 AND P3, CONNECT OUTGOING SIGNAL LINE TO P2 AND K51.
 14. INPUT POWER LEADS SHOULD BE SECURED IN CLAMP MOUNTED ALONGSIDE TERMINAL BLOCKS
 15. THIS ISSUE OF THE WIRING DIAGRAM APPLIES TO SETS WHOSE BASE SERIAL NUMBER IS ABOVE 600
 16. USE RADIO INTERFERENCE SUPPRESSOR FOR INSTALLATIONS REQUIRING A DECREASED RF INTERFERENCE. FOR OTHER INSTALLATION, OMIT SUPPRESSOR AND CONNECT INPUTS DIRECTLY TO TERMINALS AS SHOWN.
 17. 51088 RADIO INTERFERENCE SUPPRESSOR IS OPTIONAL EQUIPMENT. IT IS TO BE MOUNTED OUTSIDE OF UNIT AT A LOCATION CONVENIENT TO THE CUSTOMER.
 18. SET GROUND AND RADIO INTERFERENCE SUPPRESSOR GROUND MUST BE CONNECTED TO THE SAME GROUND SCREW. SEE NOTE 8
 19. 178535 SPARK SUPPRESSOR ASSEM. (153631 NETWORK)

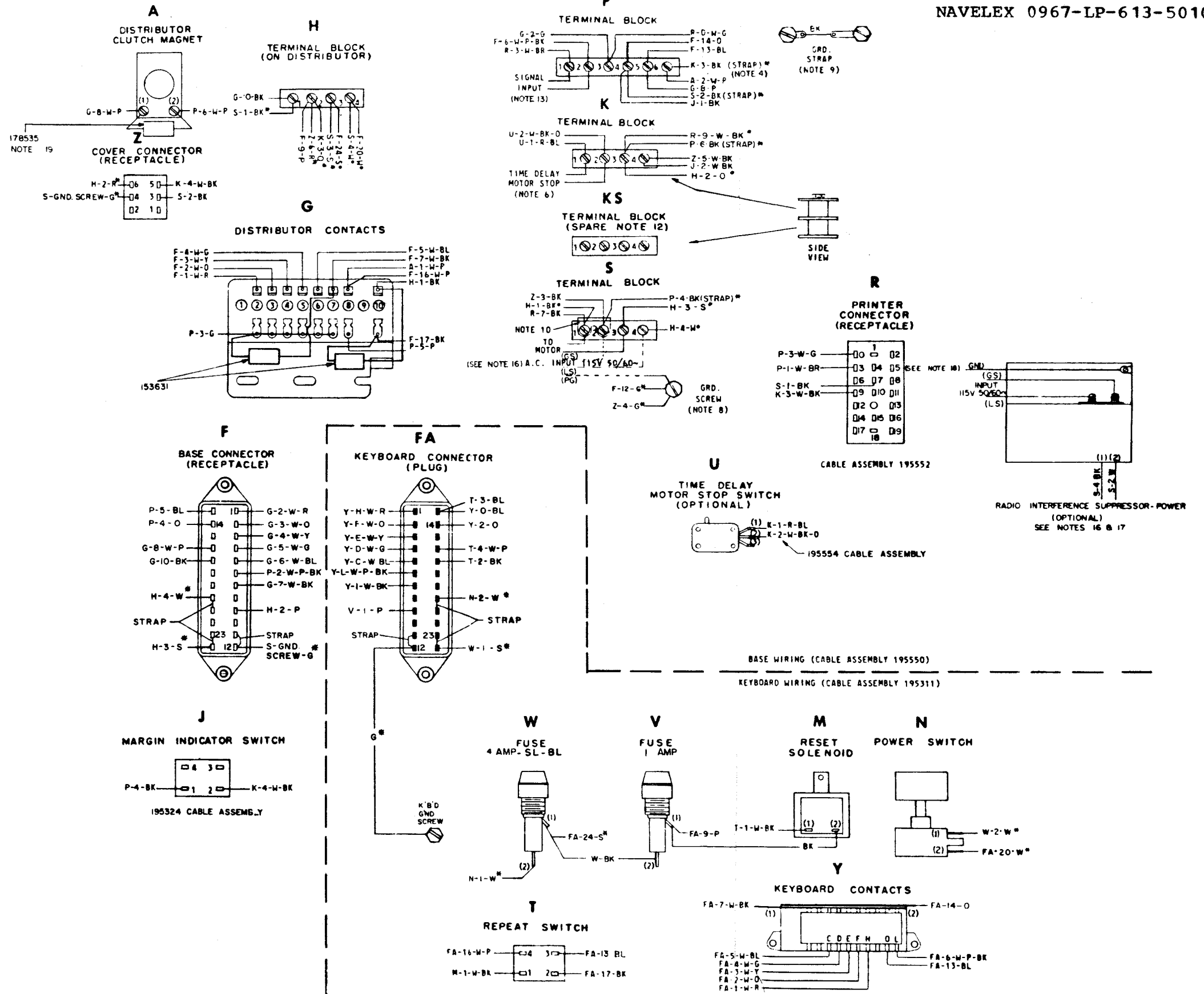

Figure 5-4. Wiring Diagram; Model 28 CPP KSR Keyboard Base LLK 2

1. WIRING LEGEND
 - DISTANT TERMINATING AREA
 - DISTANT TERMINATING DESIGNATION
 - G-9-W-P — WIRE COLOR CODE
2. COLOR CODE:

W-WHITE	W-BK--WHITE-BLACK
R-RED	W-G--WHITE-GREEN
BL-BLUE	W-P--WHITE-PURPLE
BR-BROWN	W-Y--WHITE-YELLOW
Y--YELLOW	W-R---WHITE-RED
G--GREEN	W-O---WHITE-ORANGE
S--SLATE	W-S---WHITE-SLATE
BK--BLACK	R-BL--RED-BLUE
O--ORANGE	W-P-BK--WHITE-PURPLE-BLACK
P--PURPLE	W-Y-BK--WHITE-YELLOW-BLACK
W-BL--WHITE-BLUE	
W-BR--WHITE-BROWN	
3. CONNECTORS VIEWED FROM SOLDER END
4. I51827 TERMINAL STRAP
5. SPARE TERMINAL BLOCK PROVIDED FOR CUSTOMER CONVENIENCE
6. ALL WIRES TO BE 24 GAGE EXCEPT AS NOTED
NO.18 GAGE WIRE TO BE USED
7. I03160 GROUND STRAP CONNECTED BETWEEN INNER AND OUTER PAN NEAR MOTOR
8. NUMERALS IN PARENTHESIS ARE NOT MARKED ON THE COMPONENTS BUT ARE SHOWN FOR PROPER ORIENTATION
9. GROUND SCREW LOCATED ON TERMINAL BLOCK MOUNTING BRACKET FOR CUSTOMERS TERMINAL GROUND CONNECTION

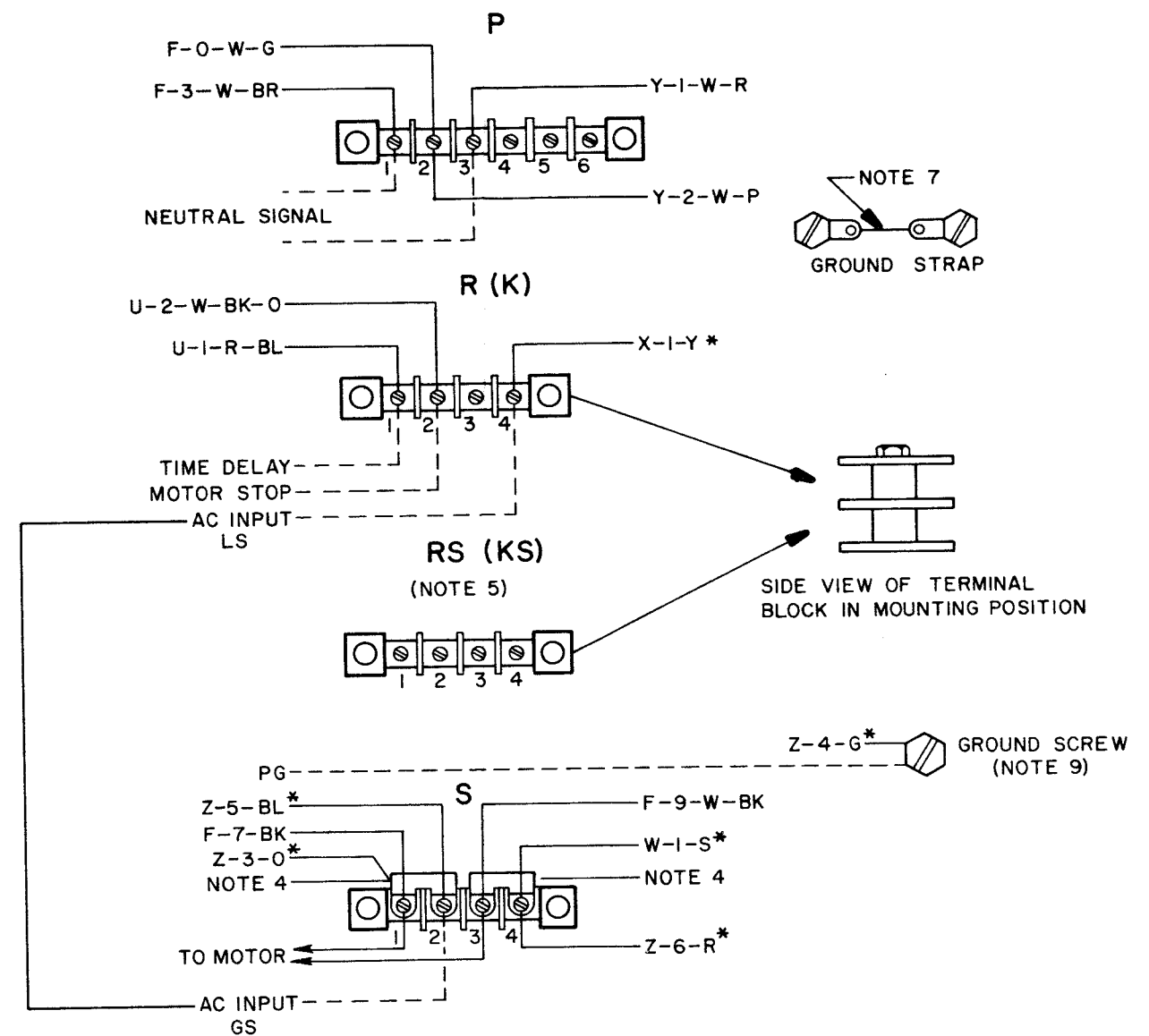
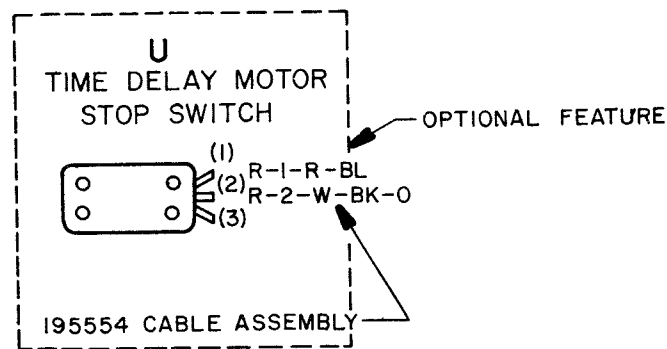
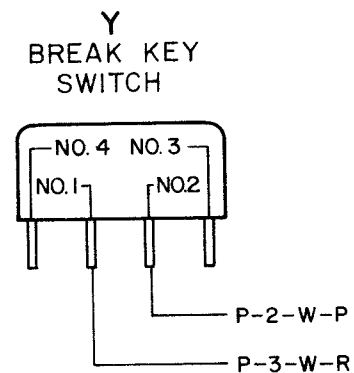
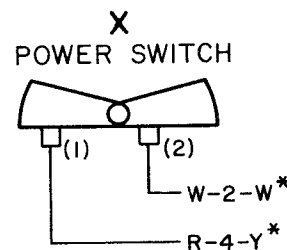
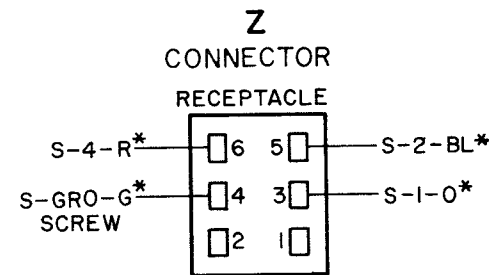
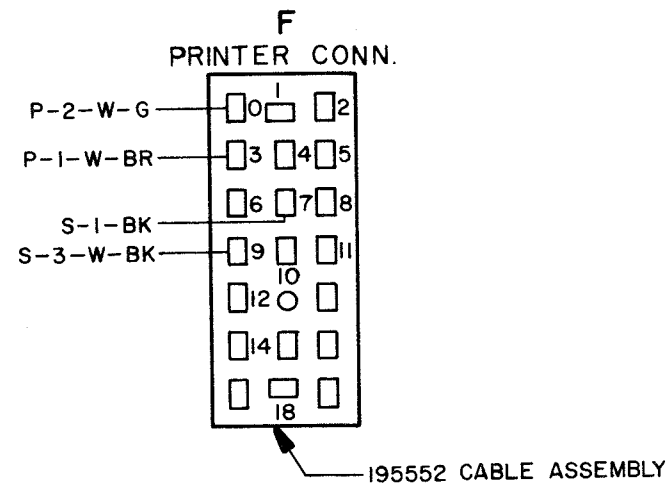

Figure 5-5. Wiring Diagram; Model 28 CPP RO Base LLB

NO	NOTES
1	WIRING CHANNEL DESIGNATED BY "R" DOES NOT REPRESENT CABLES, BUT ASSISTS IN TRACING CONNECTIONS
2	COLOR CODE: BK-BLACK BL-BLUE W-WHITE R-RED Y-YELLOW BR-BROWN P-PURPLE O-ORANGE S-SLATE G-GREEN
3	COLOR LEGEND: R- CHANNEL IDENTIFICATION W- CHANNEL WIRE NUMBER B- WIRE COLOR CODE
4	
5	CONNECTOR VIEWED FROM SOLDERED TERMINAL ENDS.
6	
7	THESE LEADS FURNISHED WITH FUNCTION BOX.
8	NORMALLY OPEN CONTACTS NORMALLY CLOSED CONTACTS
9	A COMPLETE LP UNIT USES ONLY ONE STUNT BOX. MAKE APPROXIMATE (.....) CONNECTIONS TO COMPLETE CIRCUIT.
10	TRANSFER CONTACTS REAR CONTACTS NORMALLY OPEN REAR CONTACTS NORMALLY CLOSED
11	THE FOLLOWING STUNT BOXES ARE WITHOUT SWITCH ASSEMBLIES: AX, ADL.
12	THESE TWO TERMINALS ARE USED WHEN LP IS EQUIPPED WITH XD CONT. PAGE FEED OUT OR XD CONT. HORIZ. TAB IF BOTH FEATURES ARE USED, THEY ARE WIRED IN SERIES TO THESE TERMINALS.
13	USE 39522RM STRAP FOR LP 95,96,97,102,122
14	THE 159611 SIGNAL BELL AND THE .95353 CABLE ASSEMBLY ARE CONTAINED ON THE LP111 ONLY.
15	A THE LP111 IS FACTORY WIRED FOR 60MA OPER. B THE LP111 MAY BE CONVERTED FOR 20-30MA. OPERATION BY THE CUSTOMER.
16	FOR AFY STUNT BOX, CONTACT IS OVER SLOT 30.
17	195269 STRAP CONNECTED FROM TERMINAL 6 TO CONNECTOR BRACKET MOUNTING SCREW FOR 179613 AND 179644 R.F. SUPPRESSION MODIFICATION KITS.

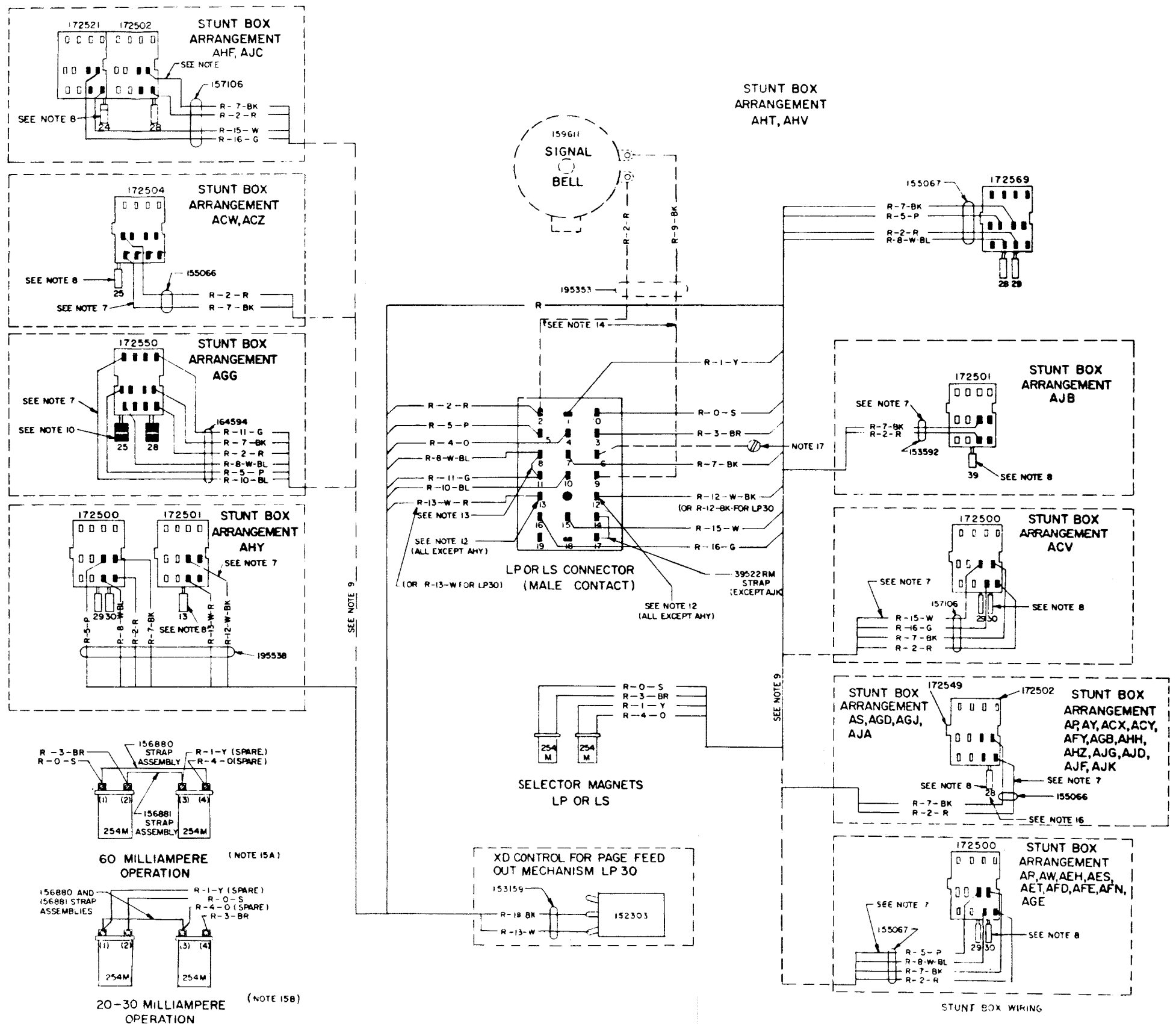

Figure 5-6. Wiring Diagram; Model 28 CPP KSR and RO Typing Unit LP111

SYNCHRONOUS MOTOR UNITS

NO.	NOTES	
1.	SYNCHRONOUS MOTOR OPERATES ON REGULATED FREQUENCY ($\pm 0.75\%$) MAXIMUM AC ONLY.	
2.	CONNECT EITHER WIRE TO DESIGNATED TERMINALS OF UNIT TERMINAL BLOCK, PER WIRING DIAGRAM OF ASSOCIATED UNIT	
3.	MOTOR LEADS OF SAME COLOR ARE INTERCHANGEABLE.	
5.	EXTERNAL NOISE SUPPRESSION NETWORK CONSISTING OF 100 OHM, 1/2 WATT RESISTOR IN SERIES WITH 0.25 MFD 1K V CAPACITOR CONNECTED ACROSS YELLOW AND BROWN WIRES. (FOR LMU45,46)	
6.	MOTOR GROUND LEAD (GREEN) TERMINAL MUST BE FASTENED TO MOUNTING CRADLE OF MOTOR UNDER A SEPARATE GROUND SCREW ONLY. A SCREW USED FOR ANOTHER PURPOSE CANNOT BE USED FOR GROUNDING (UNDERWRITERS LABORATORIES REQUIREMENT).	
7.	WIRE COLOR CODE: BK - BLACK R - RED BL - BLUE O - ORANGE BR - BROWN Y - YELLOW P - PURPLE S - SLATE W - WHITE G - GREEN	
8.	LMU	STARTING CAPACITOR VALUE
	3,15,21,30,33,36,37,38,42,46,49,51,52	43-48 MFD
	11,12	170-226 MFD
	35	64-77 MFD
	55	15-18 MFD
	19,20,24,26,31,45,56	88-108 MFD
	50,	161-193 MFD

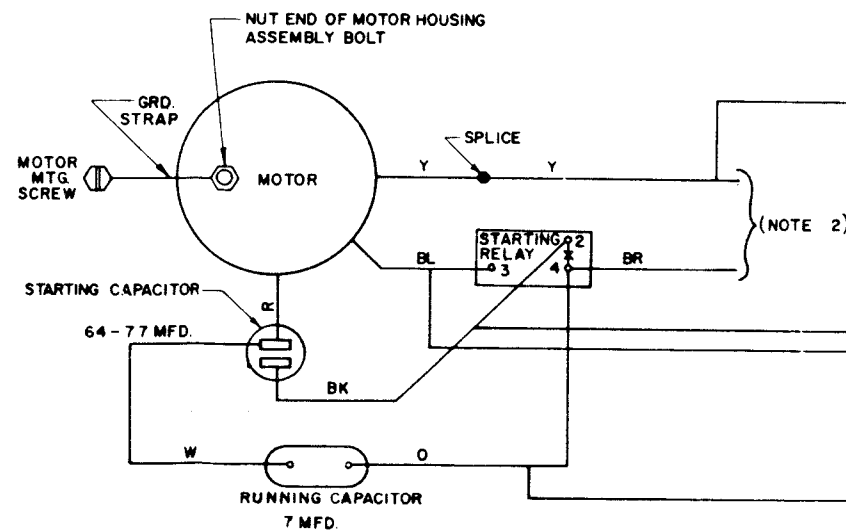
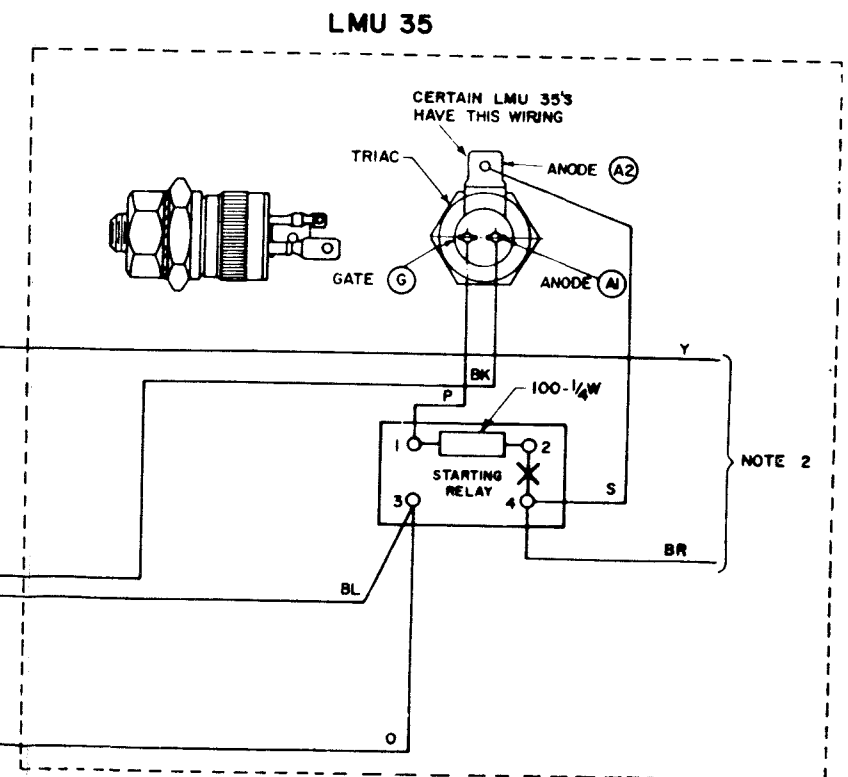
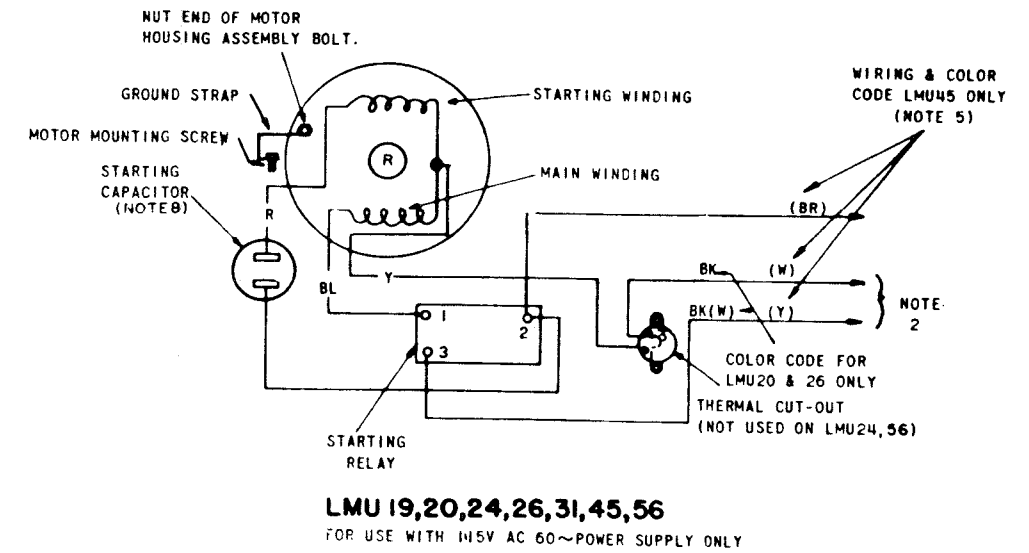
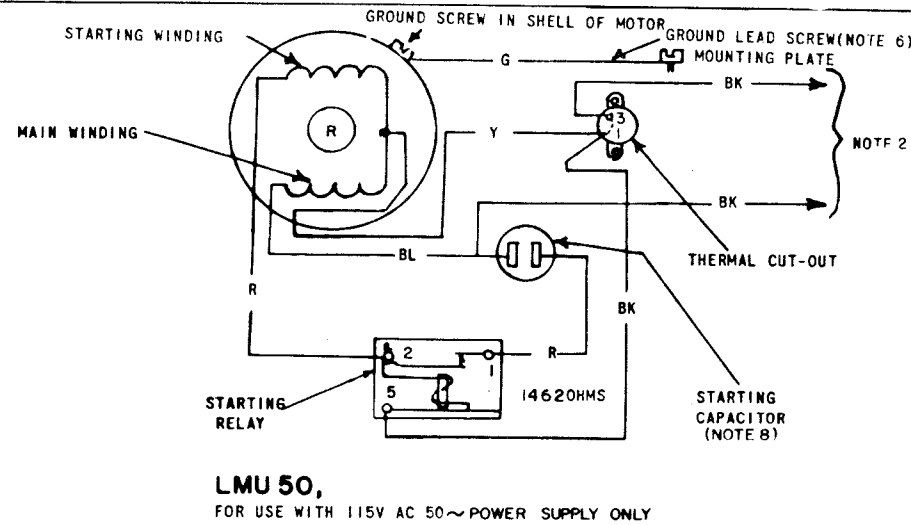
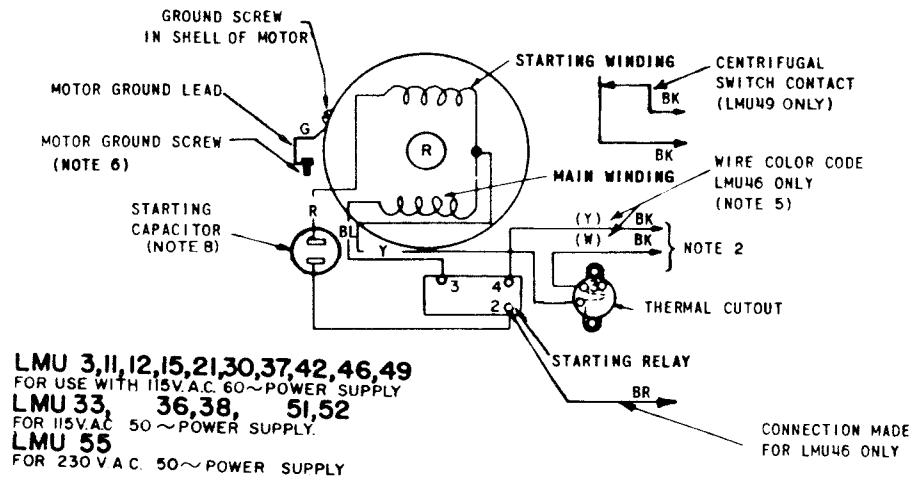

Figure 5-7. Wiring Diagram; Model 28 CPP Motor Units LMU37 and LMU51

Table 5-5. Lamp, Photocell, Fuse,
and Semiconductor Index

Qty	Name, Type, Part Number	Function, Location	Energizing Voltage
KEYBOARD AND DISTRIBUTOR ASSEMBLIES			
5	Lamps, Incandescent, 329266.	Photocell light source, Keyboard Transmitter.	4.5 VAC
6	Lamps, Incandescent, 329266.	Photocell light source, Distri- butor.	4.5 VAC
1	Photocell Assembly, 5 cells, 333094 (See Note).	Light sensors, Keyboard Trans- mitter.	--
1	Photocell Assembly, 6 cells, 333148 (See Note).	Light sensors, Distributor	--
NOTE			
If photocell problems are encountered, replace entire assembly. It is not recommended that photocells be re- placed individually.			
1	Diode Assembly, 329272.	Voltage dropping network for lamp assemblies, Keyboard Base.	--
ELECTRICAL SERVICE ASSEMBLIES			
2 (KSR) 1 (RO)	Fuse, 0.5 Amp 131807	ESA power supply to protect power supply voltage regulator and subsequent ESA PCB circuits.	--
2 (KSR) 1 (RO)	Fuse, 0.8 Amp, Slo-Blo 162360	ESA input circuit to protect ESA circuitry.	--
1 (KSR)	Diode, D-2, 177108	ILK circuit board assembly - R3 shunt switch.	--

Table 5-5. Lamp, Photocell, Fuse,
and Semiconductor Index - Continued

Qty	Name, Type, Part Number	Function, Location	Energizing Voltage
13 (KSR) 10 (RO)	Varistor, 100 Amp, 178844	Power supply circuit card ± 7 VDC reference voltage network and SMD and CMD circuit card temperature compensation circuits.	--
2 (KSR) 1 (RO)	Zener diode, 1N750A, 4.7 VDC $\pm 5\%$ 181667	ESA SMD and CMD temperature compen- sation reference voltage	± 4.7 VDC
1 (KSR)	Transistor, power, 181675	CMD assembly, $+47$ to $+53$ VDC input circuit voltage regulator stage.	--
8 (KSR) 4 (RO)	Diode, 1N4383 182520	Power supply circuit card rectifier diodes in ± 58 VDC unregulated output supply to reference Zener diodes.	--
2 (KSR)	Diode, 1N914, 197464	CMD DC amplifier transistor Q1 base protection circuitry.	--
1 (KSR)	Diode, 312341	CMD DC amplifier transistor Q4 emitter voltage diode	--
2 (KSR) 1 (RO)	Transistor, power, 318835	Power supply card power transistor, series voltage regu- lating circuit.	--
2 (KSR) 1 (RO)	Transistor, 2N2270, 321145	Power supply card gain transistor, series voltage regulating circuit.	--
1 (KSR)	Diode, Zener, 39 VDC $\pm 5\%$, 321149	CMD assembly, regulator voltage reference	39 VDC

Table 5-5. Lamp, Photocell, Fuse,
and Semiconductor Index - Continued

Qty	Name, Type, Part Number	Function, Location	Energizing Voltage
3	Diode, 1N457A, 321154	SMD assembly: tran- sistor Q1, Q5 base protection circuit diodes, and transient suppression network diode	--
4	Diode, 1N482A, 321156	SMD assembly: DC amplifier Q4 collector clamps, and DC amplifier Q8, Q9 emitter diodes.	--
2 (KSR) 1 (RO)	Zener Diode, 1N748A, 3.9 VDC +5% 321161	SMD, CMD regulator circuit voltage reference diodes.	3.9 VDC
2 (KSR) 1 (RO)	Transistor, 2N3638A, 321165	SMD, CMD DC amplifier circuits	--
3 (KSR) 2 (RO)	Transistor, 2N1893 321166	SMD, CMD DC amplifier circuits	--
2 (KSR) 1 (RO)	Transistor, 2N4036, 321261	SMD shunt regulator amplifier, power regulator stage; CMD DC amplifier circuit	--
4 (KSR) 2 (RO)	Zener Diode, 1N4749A, 321286, 24 VDC	Power supply, 24 VDC reference voltage Zener diodes to maintain series voltage regulator transistor base at 48 VDC	24 VDC
1	Transistor, 2N3053, 323844	SMD shunt regulator, power regulator stage	--
1	Transistor, 40319, 323845	SMD series regulator transistor, power regulator stage	--

Table 5-5. Lamp, Photocell, Fuse,
and Semiconductor Index- Continued

Qty	Name, Type, Part Number	Function, Location	Energizing Voltage
3 (KSR)	Transistor, 2N3565, 323934	LLK amplifier circuits	--
5 (KSR) 2 (RO)	Transistor, 2N4121, 324144	SMD, CMD DC amplifier circuit transistors; LLK amplifier circuit transistors.	--
4 (KSR) 2 (RO)	Zener diode, 7.2 VDC, 327794	Power supply reference voltage diodes for ± 7 VDC output	7.2 VDC

are those provided at the end of this chapter and indexed in table 5-4.

(3) Troubleshooting for an ESA is required only to repair the power supply or to correct wiring defects in case of loose, broken, or faulty wiring. Wiring can be checked by following the different circuits on the appropriate wiring diagram, point-to-point, and comparing with the actual equipment wiring.

d. Power Supply Troubleshooting Procedures. If trouble should develop, it may be found by performing the checks outlined in the troubleshooting procedures in table 5-6 using a multimeter. The following instructions are

applicable when troubleshooting power supply circuit cards.

(1) Colored test point jacks are provided on top of the power supply circuit card to accept standard meter probes.

(2) When a fault in the power supply is suspected but not obvious, disconnect all power from the ESA. Remove all keyer (LLK), selector magnet driver (SMD), and clutch magnet driver (CMD) circuit cards. Apply 100 to 130 volt ac power to the ESA and proceed with the troubleshooting procedure as outlined in table 5-6.

WARNING

Be extremely careful with capacitors, they may be

charged. A severe electrical shock may be received from a capacitor or leads connected to the power supply while it is in operation.

(3) In following the procedure outlined in table 5-6, perform step 1. If a normal response is received, proceed to Step 2. If an abnormal response is received, repair or replace card. After this procedure, return to Step 1. Next, perform Step 2 and so on in the same manner.

(4) If this troubleshooting fails to reveal the difficulty, check for loose or cold solder connection or a broken or misplaced wire in the ESA. Recheck all wiring as indicated in paragraph 5-2.2c(1).

(5) Continually blowing fuses indicate a shorted component or components. Disconnect power, remove the circuit card assembly and make continuity checks between circuit card connector terminals B and N, N and H, and B and H. A zero or near zero reading on the one ohm scale of a multimeter indicates a short; disregard any other reading. Also, check continuity between the power transistor case and its heat sink; the power transistor must be electrically isolated from the heat sink with mica insulators. If the board assembly checks satisfactorily, examine the power line filter, power transformer, and rectifier filter capacitor for a shorted condition. (These components are located within the electrical service assembly.)

(6) Failure to detect the fault using the methods described above normally indicates a loose or cold solder connection, broken or misplaced wire in the service assembly. Check all wiring according to appropriate wiring diagrams.

e. Selector Magnet Driver (SMD) Troubleshooting Procedures. Table 5-7 provides information for use as a guide when troubleshooting the SMD. The following recommendations also are applicable when troubleshooting SMDs.

NOTE

The TP323810 selector magnet driver (SMD) is a circuit card assembly that needs only to be plugged into a properly keyed (polarizing key between pins E and F) 15-pin receptacle which is wired into the electrical service assembly (ESA).

(1) It is recommended that any damaged TP323810 selector magnet driver (SMD) unit be replaced in the field and maintained in a repair center. The repair center should have equipment capable of simulating normal operating condition.

(2) It is also recommended that the SMD be radio frequency interference (rfi) suppression tested after servicing and prior to final installation. Failures from this standpoint are not necessarily recognized by monitoring a typical communications operation.

f. Low-Level Keyer (LLK) Troubleshooting Procedures. Table 5-8 provides information

Table 5-6. Power Supply Troubleshooting Procedures (0.5 Ampere Card)

Step	Action	Probe Position	Normal Response	Abnormal Response and Procedure
1	Check Voltage from -7 test jack.	COM-7	<p>Meter reading should be: Min-6.6 volts Max-7.8 volts</p> <p>If normal, proceed to Step 2.</p>	<p><u>RESPONSE</u>: Meter reading of zero volt.</p> <p><u>DIFFICULTY</u>: CR5 shorted or R5 open.</p> <p><u>PROCEDURE</u>: Remove CR5 short-power supply card and repair or replace.</p> <p>Recheck Step 1.</p> <p><u>RESPONSE</u>: Meter reading of +57 volts to +90 volts.</p> <p><u>DIFFICULTY</u>: CR5 open</p> <p><u>PROCEDURE</u>: Remove power supply card and repair or replace.</p> <p>Recheck Step 1.</p>
2	Check voltage from +7 test jack.	COM +7	<p>Meter reading should be: Min +6.6 volts Max +7.8 volts</p> <p>If normal, proceed to Step 3</p>	<p><u>RESPONSE</u>: Meter reading of zero volt.</p> <p><u>DIFFICULTY</u>: CR6 shorted or R4 open.</p> <p><u>PROCEDURE</u>: Remove power supply card and repair or replace.</p> <p>Recheck Step 1.</p> <p><u>RESPONSE</u>: Meter reading of +57 volts to +90 volts.</p> <p><u>DIFFICULTY</u>: CR6 open.</p> <p><u>PROCEDURE</u>: Remove power supply card and repair or replace.</p>

Table 5-6. Power Supply Troubleshooting
Procedures (0.5 Ampere Card) - Continued

Step	Action	Probe Position	Normal Response	Abnormal Response and Procedure
3	Check voltage from UNREG. test jack.	COM UNREG.	<p>Meter reading should be: Min +57 volts Max +90 volts</p> <p>If normal, proceed to Step 4.</p>	<p>Recheck Step 1.</p> <p><u>RESPONSE</u>: Meter reading of zero volt.</p> <p><u>DIFFICULTY</u>: Loose or blown fuse.</p> <p><u>PROCEDURE</u>: Remove power supply card and replace fuse.</p> <p>Proceed to Step 5.</p> <p><u>RESPONSE</u>: Meter reading indicates voltage which is too low.</p> <p><u>DIFFICULTY</u>: CR1 and/or CR4 open or shorted. C8 defective. T1 and power line filter defective.</p> <p><u>PROCEDURE</u>: Remove power supply card or defective parts and repair or replace.</p> <p>Recheck Step 1.</p>
4	Check voltage from +50 test Jack.	COM +50	<p>Meter reading should be: Min +47 volts Max +53 volts</p> <p>If normal, end test.</p>	<p><u>RESPONSE</u>: Meter reading of zero volt.</p> <p><u>DIFFICULTY</u>: Q1 and/or Q2 open.</p> <p><u>PROCEDURE</u>: Remove power supply card and repair or replace.</p> <p>Recheck Step 1.</p>

Table 5-6. Power Supply Troubleshooting
 Procedures (0.5 Ampere Card) - Continued

Step	Action	Probe Position	Normal Response	Abnormal Response and Procedure
5	Check voltage from UNREG. test jack.	COM UNREG.	Meter reading should be: Min +57 volts Max +90 volts	<p><u>RESPONSE:</u> Meter reading of more than zero volt but less than +47 volts.</p> <p><u>DIFFICULTY:</u> Too many shorting straps across CR8, CR9, CR10, and CR11.</p> <p><u>PROCEDURE:</u> Remove power supply card and remove straps, as necessary to increase voltage. Replace card.</p> <p>Recheck Step 1.</p> <p><u>RESPONSE:</u> Meter reading of +57 volts to +90 volts.</p> <p><u>DIFFICULTY:</u> Q1 and/or Q2 shorted.</p> <p><u>PROCEDURE:</u> Remove power supply card and repair or replace.</p> <p>Recheck Step 1.</p> <p><u>RESPONSE:</u> Meter reading of zero volt.</p> <p><u>DIFFICULTY:</u> Repeated fuse blowing.</p>

Table 5-6. Power Supply Troubleshooting
Procedures (0.5 Ampere Card) - Continued

Step	Action	Probe Position	Normal Response	Abnormal Response and Procedure
			Return to Step 4.	<p><u>PROCEDURE:</u> Disconnect power and remove power supply card. Make continuity checks between card terminals B and N, N and H, B and H. A zero or near zero reading on the 1-ohm scale of a multimeter indicates a short. Check continuity between Q1 case and its heat sink (Q1 must be electrically isolated from heat sink with mica insulators). If the power supply card checks satisfactorily, check power line filter T1 and C8 for shorted condition. Repair or replace card.</p> <p>Recheck Step 1.</p> <p><u>RESPONSE:</u> Meter reading indicates voltage which is too low.</p> <p><u>DIFFICULTY:</u> CR1 and/or CR4 open or shorted. C8 defective. T1 and power line filter defective.</p> <p><u>PROCEDURE:</u> Remove power supply card or defective parts and repair or replace.</p> <p>Recheck Step 1.</p>

Table 5-7. Selector Magnet Drive Troubleshooting Guide

	Symptom	Probable Cause
(a)	Switching levels out of tolerance	(1) Improper adjustment of R3 and/or R15 (2) Q1 and/or Q5 low gain. (3) CR5 defective or out of tolerance
(b)	Circuit always marking	(1) Q8 open (2) Q1, Q5, Q6, Q7 or Q9 collector-emitter shorted
(c)	Circuit always spacing	(1) Q1, Q5, Q6, Q7, or Q9 collector-emitter open. (2) Q8 collector-emitter shorted (3) CR13 open
(d)	Output current too high	R23 out of tolerance
(e)	Output current too low	R23 out of tolerance
(f)	Transient suppressor network ineffective	(1) CR14 open (2) R24 open (3) C6 open
(g)	Loss of receiving margin	(1) Q8, Q9 improper gain (2) C4, C5, or C6 out of tolerance or defective (3) CR14 shorted

Table 5-8. Low-Level Keyer Troubleshooting Guide

Symptom	Probable Cause
(a) Circuit always marking	Photocell in keyboard or distributor shorted
(b) Circuit always spacing	Photocell in keyboard or distributor open circuited
(c) Mark - space bits detectable but will not go positive on mark	Q3 open and/or Q2 shorted
(d) Mark - space bits detectable but will not go negative on space	Q4 open and/or Q1 shorted

for use as a guide when troubleshooting the LLK. The following recommendations also are applicable when troubleshooting LLKs.

NOTE

The TP323130 low-level keyer is a circuit card assembly that needs only to be plugged into a properly keyed 15-pin receptacle which is wired into an appropriate ESA.

(1) It is recommended that any damaged keyer card be replaced in the field and maintained in a repair center. The repair center should have equipment capable of simulating normal operating conditions.

(2) It is also recommended that the keyer and associated filter cards (if any) be radio frequency interference (rfi) suppression tested after servicing and prior to final installation. Failures from

this standpoint are not necessarily recognized by monitoring a typical communications operation.

g. Clutch Magnet Driver (CMD) Troubleshooting Procedures. Table 5-9 provides information for use as a guide when troubleshooting the CMD. The following recommendations also are applicable when troubleshooting CMDs.

NOTE

The clutch magnet driver (CMD) is a circuit card assembly that needs only to be plugged into a properly keyed 15-pin receptacle which is wired into an appropriate electrical service assembly (ESA).

(1) It is recommended that any damaged clutch magnet driver (CMD) unit be replaced in the field and maintained in a repair center. The repair center should have equipment capable of

Table 5-9. Clutch Magnet Driver Troubleshooting Guide

Symptom	Probable Cause
(a) Switching levels out of tolerance	(1) Improper adjustment of R7 (2) Q1 low gain (3) CR7 defective or out of tolerance
(b) Circuit always marking	(1) Q3 open (2) Q1, Q2, or Q4 collector-emitter shorted
(c) Circuit always spacing	(1) Q1, Q2, or Q4 open (2) Q3 collector-emitter shorted (3) CR8 open
(d) Output current too high	(1) CR2 open (2) R17 out of tolerance
(e) Output current too low	(1) R2 improperly adjusted or defective (2) R17 out of tolerance
(f) Transient suppressor network ineffective	(1) CR9 open (2) R16 open (3) C4 open

simulating normal operating conditions.

(2) It is also recommended that the CMD be radio frequency interference (rfi) suppression tested after

repair and prior to final installation. Failures from this standpoint are not necessarily recognized by monitoring a typical communications operation.

NO.	NOTES										
1.	<p>WIRING LEGEND:</p> <p>— DISTANT TERMINATING AREA — DISTANT TERMINATING DESIGNATION A-1-W WIRE COLOR CODE</p>										
2.	<p>COLOR CODE:</p> <table border="0"> <tr> <td>BK - BLACK</td> <td>G - GREEN</td> </tr> <tr> <td>BR - BROWN</td> <td>BL - BLUE</td> </tr> <tr> <td>R - RED</td> <td>P - PURPLE</td> </tr> <tr> <td>O - ORANGE</td> <td>S - SLATE</td> </tr> <tr> <td>Y - YELLOW</td> <td>W - WHITE</td> </tr> </table>	BK - BLACK	G - GREEN	BR - BROWN	BL - BLUE	R - RED	P - PURPLE	O - ORANGE	S - SLATE	Y - YELLOW	W - WHITE
BK - BLACK	G - GREEN										
BR - BROWN	BL - BLUE										
R - RED	P - PURPLE										
O - ORANGE	S - SLATE										
Y - YELLOW	W - WHITE										
3.	CONNECTORS VIEWED FROM SOLDER TERMINAL SIDE.										
4.	* INDICATES 18 GA. WIRE.										
5.	USE 4 AMP. SL-BL FUSE.										
6.	NUMBERS IN PARENTHESES ARE NOT IDENTIFIED ON COMPONENTS.										
7.	333079 CABLE ASSEMBLY.										
8.	333151 CABLE ASSEMBLY.										
9.	<p>ASSOCIATED WD'S</p> <p>2900WD ACTUAL OF LMU37 8764WD ACTUAL OF LPC 403 8143WD SCHEMATIC OF 323810 SMD CARD 8763WD ACTUAL OF LP156 8299WD ACTUAL AND SCHEMATIC OF 319204 SELECTOR 8724WD ACTUAL OF 323120 ESA 8725WD SCHEMATIC OF 323120 ESA 8726WD ACTUAL OF 323121 ESA 8727WD SCHEMATIC OF 323121 ESA 8729WD SCHEMATIC OF 28RFB0001A, 28RFB0001A, AND VSL500 INCORPORATING 32316 MODIFICATION KIT</p>										
10.	S-NUMBER 61,600 S										
11.	--- INDICATES SHIELDED WIRE.										
12.	333147 GROUND STRAP IS USED IN CONJUNCTION WITH OLD STYLE TWO PIECE BONDED KEYBOARD END FRAMES AND IS NOT USED ON LATER STYLE UNITS USING SOLID ONE PIECE END FRAMES.										

DISTRIBUTOR WIRING

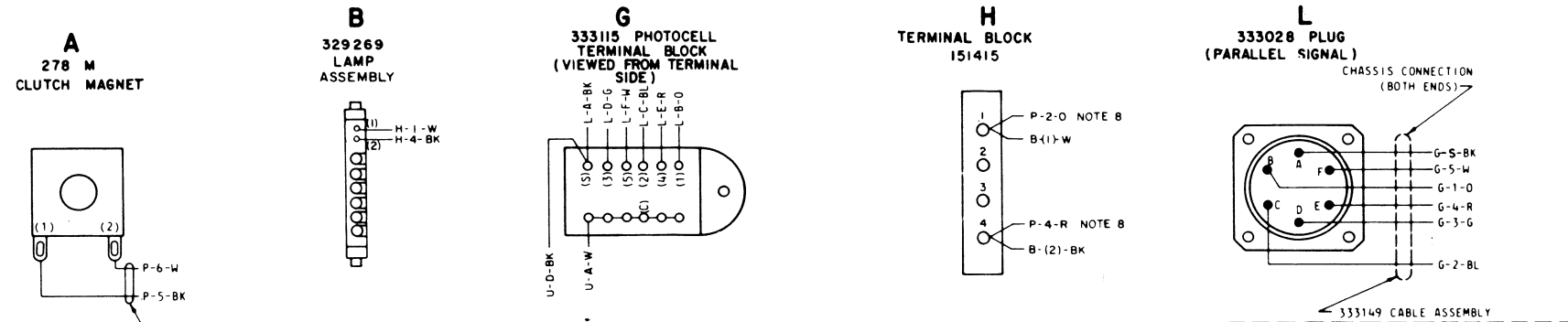

KEYBOARD WIRING

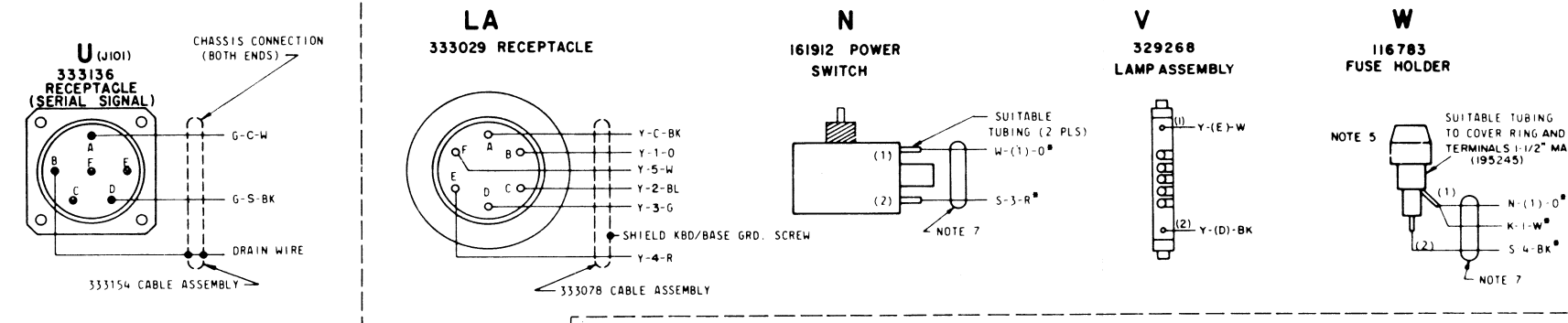

BASE WIRING

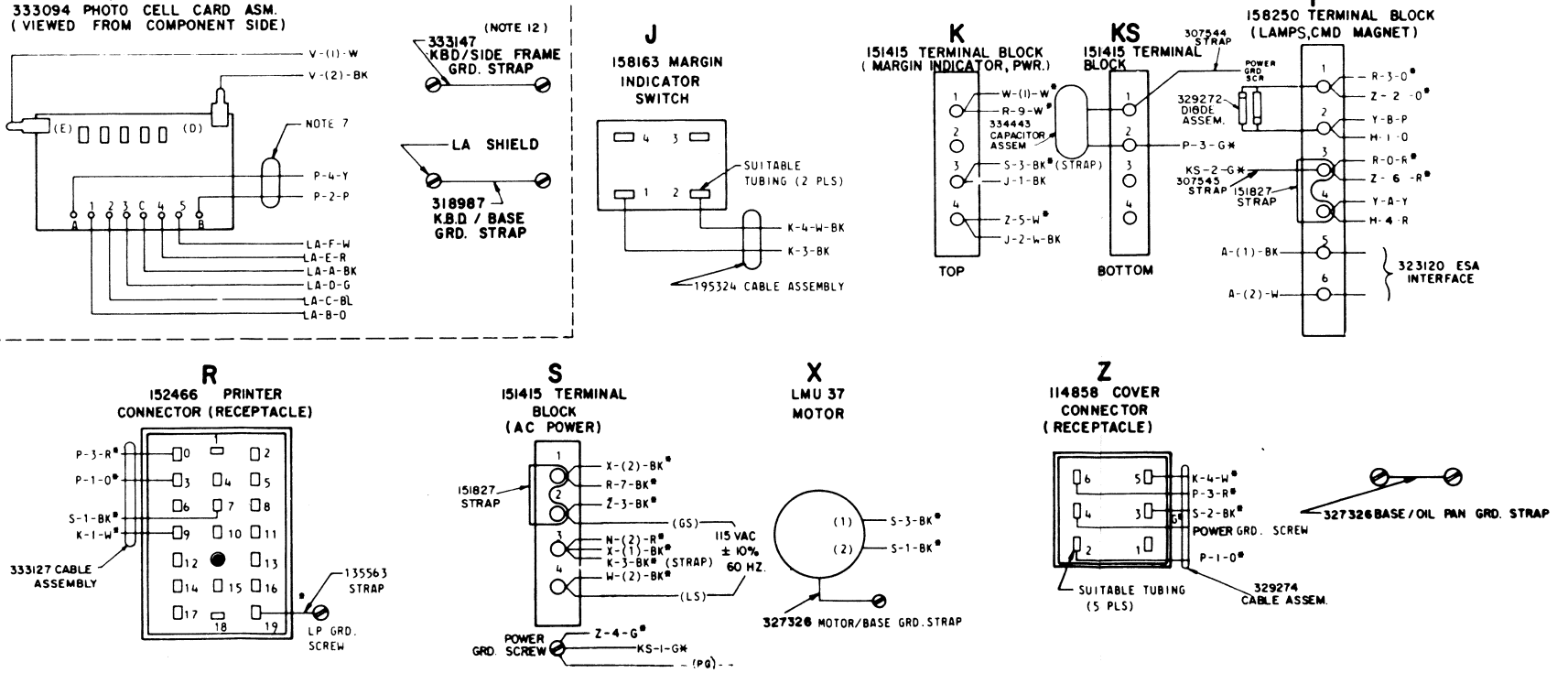





Figure 5-8. Wiring Diagram; Model 28 CPP KSR (Less Cover and Printer)

NO.	NOTES
1.	 INDICATES FEMALE TERMINAL  INDICATES MALE TERMINAL
2.	 INDICATES SINGLE SHIELDING  INDICATES DOUBLE SHIELDING
3.	SL-BL INDICATES SLOW BLOWING
4.	TERMINAL DESIGNATIONS ENCLOSED IN PARENTHESES ARE FOR REFERENCE ONLY AND ARE NOT MARKED ON COMPONENT.
5.	S NUMBER 61,600 S
6.	ASSOCIATED WIRING DIAGRAMS 2900WD ACTUAL OF LMU37 8764WD ACTUAL OF LFC403 8763WD ACTUAL OF LP156 8724WD ACTUAL OF 323120 ESA 8721WD ACTUAL OF 323121 ESA 8299WD ACTUAL AND SCHEMATIC OF 319204 SELECTOR 8143WD SCHEMATIC OF 323810 SMD CARD 8725WD SCHEMATIC OF 323120 ESA 8727WD SCHEMATIC OF 323121 ESA 8728WD ACTUAL OF 28RFC8001A, 28-RFH8001A, AND VSL500 INCORPORATING 323116 MODIFICATION KIT
7.	RESISTANCE VALUES IN OHMS UNLESS OTHERWISE SPECIFIED
8.	28-RFC8001A OMIT: 323120 ESA 323121 ESA 28-RFH8001A INCLUDE: 323120 ESA 323121 ESA VSL500 INCORPORATING 323116 MOD. KIT INCLUDE: 323120 ESA 323121 ESA

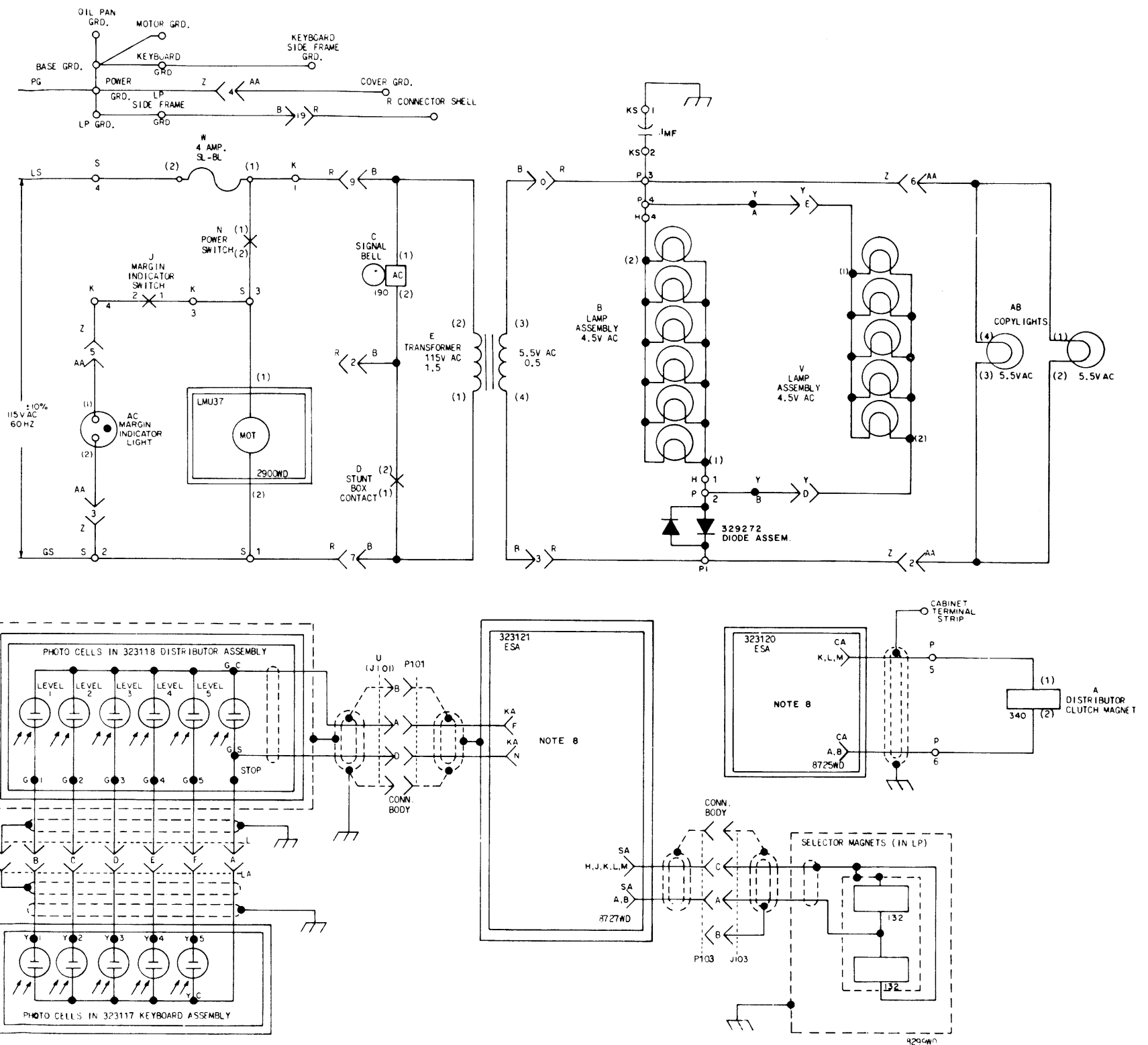

Figure 5-9. Schematic Diagram; Model 28 CPP KSR

NO.	NOTES
1	<ul style="list-style-type: none"> ↗ INDICATES FEMALE TERMINAL ↖ INDICATES MALE TERMINAL
2	TERMINAL DESIGNATIONS ENCLOSED IN PARENTHESES ARE FOR REFERENCE AND ARE NOT MARKED ON COMPONENT
3	○ INDICATES SHIELDED WIRE
4	193781 CUT-OUT SWITCH USED FOR 50HZ OPERATION. 122249 CUT-OUT SWITCH USED FOR 60HZ OPERATION.
5	ASSOCIATED WIRING DIAGRAMS: 2900WD - MOTOR UNITS 8177WD - COVER, PRINTER SET 8242WD - PAGE PRINTER UNIT 8179WD - REFERENCE SETS 8137WD - 32(23) E S A
6	SL-BL INDICATES SLOW-BLOWING
7	GROUND SCREW LOCATED ON TERMINAL BLOCK MOUNTING BRACKET FOR CUSTOMERS TERMINAL GROUND CONNECTION.
8	ALL VOLTAGES D.C. UNLESS OTHERWISE SPECIFIED
9	REFERENCE SPEC FOR TELETYPE CORPORATION EMPLOYEES ONLY 61351 S
10	○ INDICATES DOUBLE SHIELDED WIRE

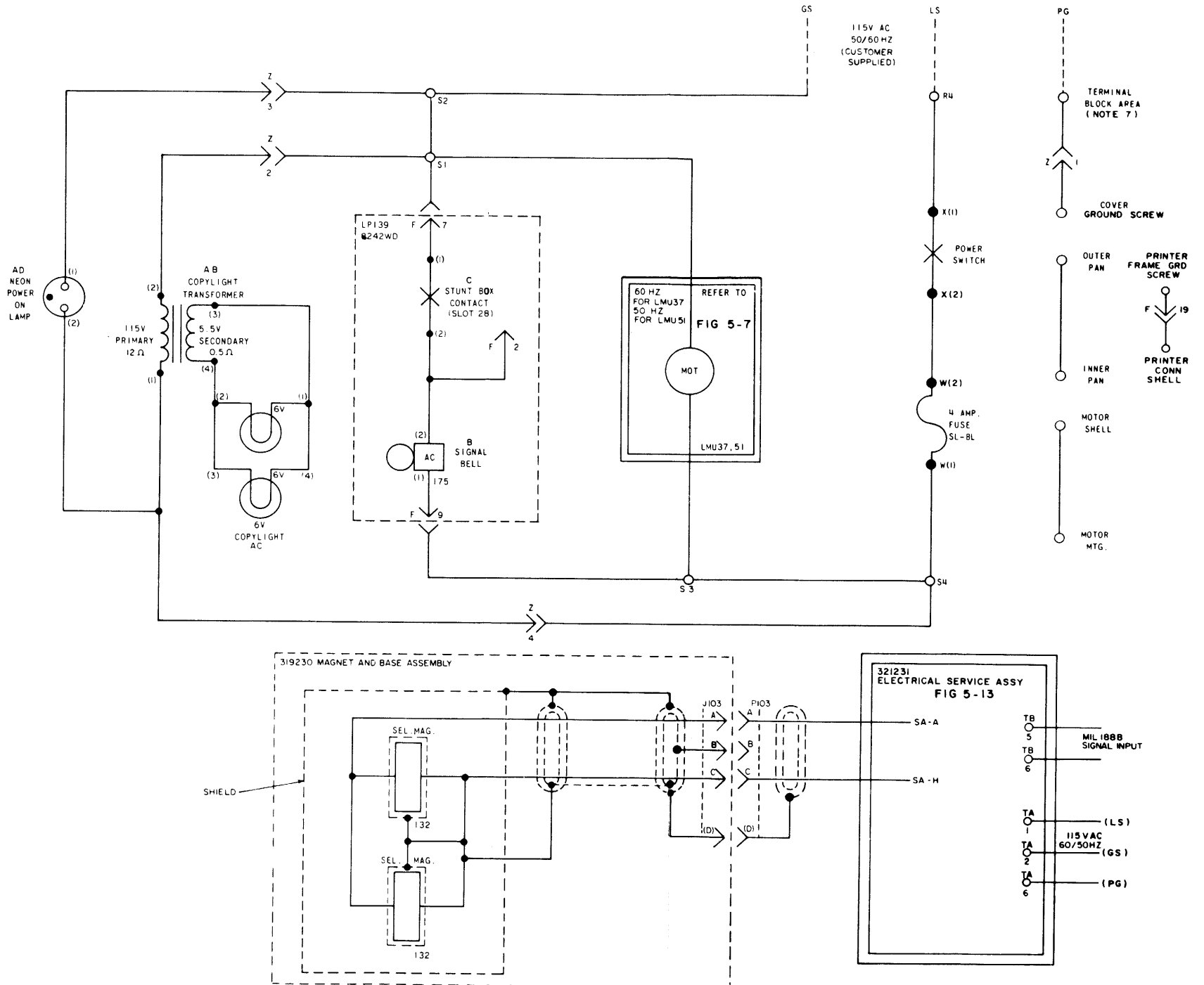

Figure 5-10. Schematic Diagram; Model 28 CPP RO

NO.	NOTES										
1.	<p>WIRING LEGEND:</p> <p>— DISTANT TERMINATING AREA — DISTANT TERMINATING DESIG.</p> <p>AB-4-BR WIRE COLOR CODE</p>										
2.	<p>COLOR CODE:</p> <table border="0"> <tr> <td>BK - BLACK</td> <td>R - RED</td> </tr> <tr> <td>BL - BLUE</td> <td>Y - YELLOW</td> </tr> <tr> <td>BR - BROWN</td> <td>W - WHITE</td> </tr> <tr> <td>O - ORANGE</td> <td>P - PURPLE</td> </tr> <tr> <td>S - SLATE</td> <td>G - GREEN</td> </tr> </table>	BK - BLACK	R - RED	BL - BLUE	Y - YELLOW	BR - BROWN	W - WHITE	O - ORANGE	P - PURPLE	S - SLATE	G - GREEN
BK - BLACK	R - RED										
BL - BLUE	Y - YELLOW										
BR - BROWN	W - WHITE										
O - ORANGE	P - PURPLE										
S - SLATE	G - GREEN										
3.	<p>✕ INDICATES SPLICE, SOLDER AND TAPE.</p>										
4.	<p>CONNECTOR VIEWED FROM SOLDER END</p>										
5.	<p>NUMERALS IN PARENTHESES ARE FOR REFERENCE ONLY AND DO NOT APPEAR ON COMPONENT.</p>										
6.	<p>USE 60373RM HEAT SHRINK TUBING ON THE CONNECTOR TERMINALS AFTER SOLDERING.</p>										
7.	<p>ON THE LPC402 THE 164856 NEON INDICATOR LIGHT IS USED AS A POWER "ON" INDICATOR.</p>										
8.	<p>COPYLIGHT SOCKETS PART OF 198562 CABLE ASSEMBLY.</p>										
9.	<p>SPLICE LEADS AB-3, AC-1, & AC-4 TAPE & TUCK & TIE NEAR "Z" CONN.</p>										
10.	<p>SPLICE LEADS AB-4, AC-2 & AC-3 TAPE & TUCK & TIE NEAR "Z" CONN.</p>										
11.	<p>ASSOCIATED WIRING DIAGRAMS:</p> <p>8137WD: 321231 ESA WIRING 8176WD: RFH8000B SCHEMATIC 8178WD: 321231 ESA SCHEMATIC 8179WD: RFH8000B 8242WD: LPI59</p>										
12.	<p>REFERENCE SPEC FOR TELETYPE CORPORATION EMPLOYEES ONLY 61351 S</p>										
13.	<p>* DENOTES 18GA - ALL OTHER WIRES 24 GA.</p>										

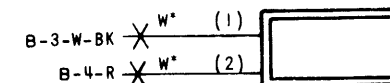
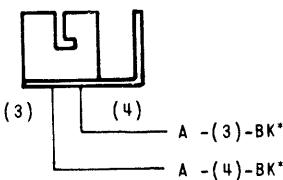
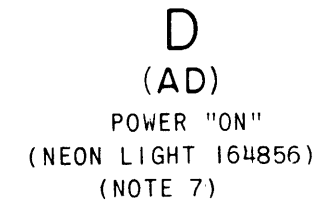
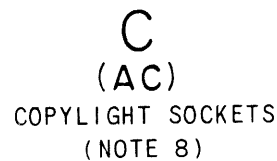
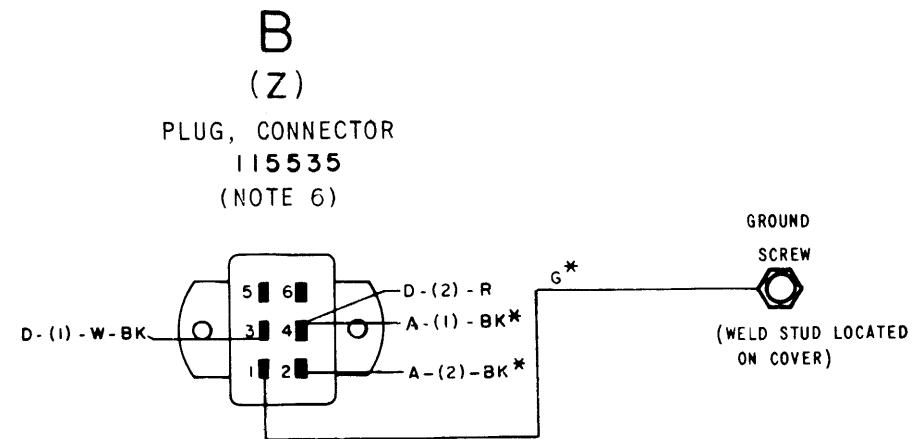
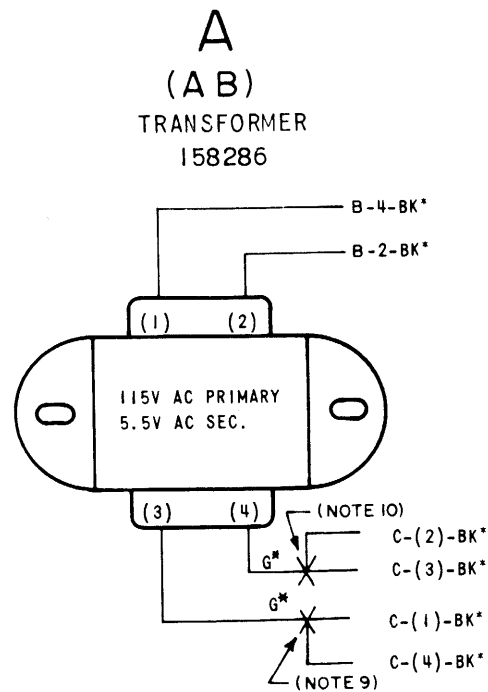
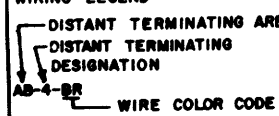



Figure 5-11. Wiring Diagram; Model 28 CPP RO
Cover LPC 402

NO.	NOTES
1.	WIRING LEGEND: 
2.	COLOR CODE: BK - BLACK R - RED BL - BLUE Y - YELLOW BR - BROWN G - GREEN O - ORANGE W - WHITE S - SLATE P - PURPLE
3.	ASSOCIATED WIRING DIAGRAMS 8724 WD 323120 ESA ACTUAL 8725 WD 323120 ESA SCHEMATIC 8726 WD 323121 ESA ACTUAL 8727 WD 323121 ESA SCHEMATIC 8728 WD 323116 MOD KIT ACTUAL 8729 WD 323116 MOD KIT SCHEMATIC 8763 WD LP 156 ACTUAL
4.	 INDICATES SPLICE SOLDER AND TAPE
5.	CONNECTOR VIEWED FROM SOLDER END.
6.	USE 155755 INSULATING SLEEVE ON THE CONNECTOR TERMINALS AFTER SOLDERING.
7.	S NUMBER 61600S
8.	* DENOTES 18 GA. ALL OTHER WIRES 24 GA.
9.	151982 INCANDESCENT LAMP
10.	TERMINAL DESIGNATIONS ENCLOSED IN PARENTHESES ARE FOR REFERENCE ONLY AND ARE NOT MARKED ON COMPONENTS.

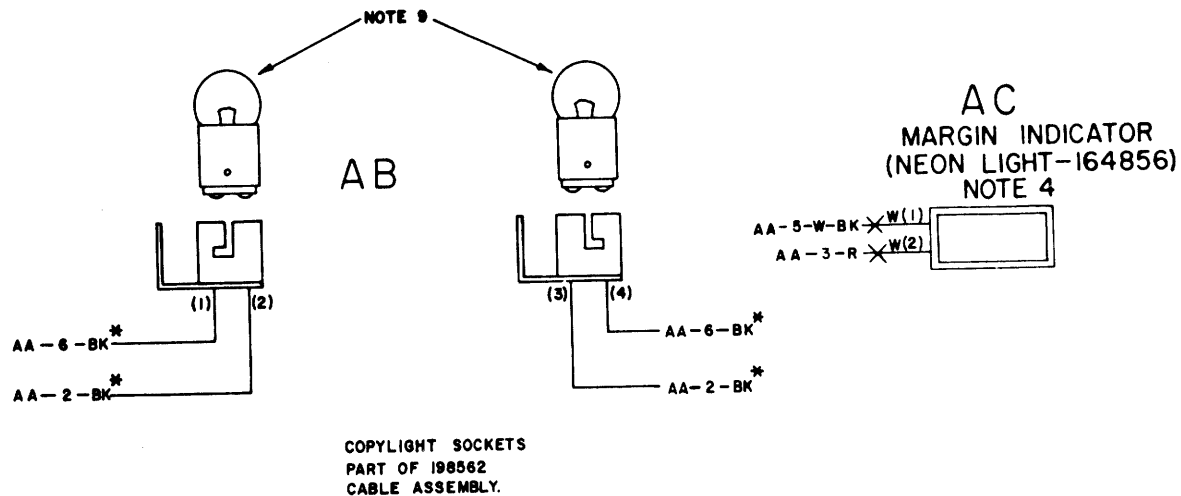
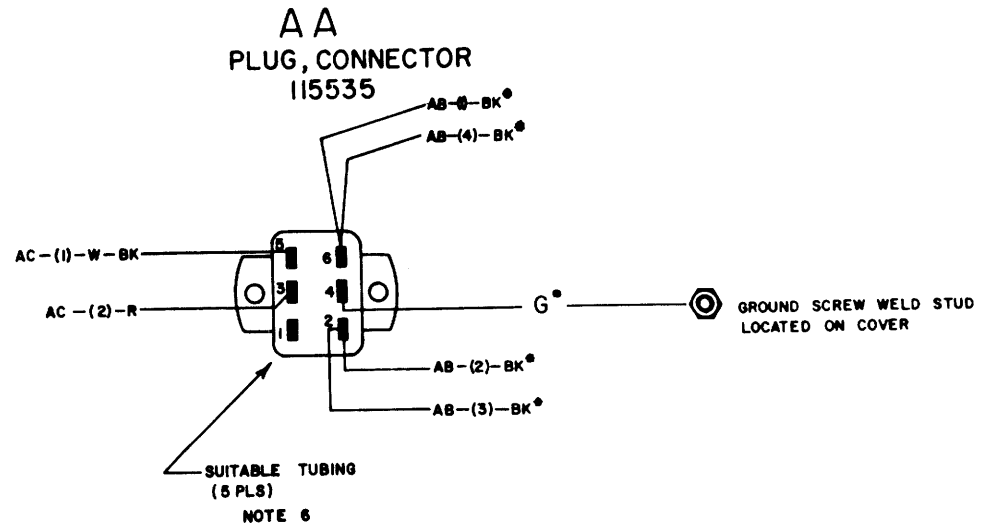



Figure 5-12. Wiring Diagram; Model 28 CPP KSR
Cover LPC403

NO	NOTES
1	ALL VOLTAGES DC UNLESS OTHERWISE SPECIFIED.
2	TERMINAL DESIGNATIONS ENCLOSED IN PARENTHESIS ARE FOR REFERENCE AND ARE NOT MARKED ON COMPONENT.
3	ALL SURFACE WIRE 24 AWG GREEN, 31784 RM, UNLESS OTHERWISE SPECIFIED. ALL STRAPPING WIRE 24 AWG BARE, 39603RM. USE SLEEVING WHERE REQUIRED. ① INDICATES 18 AWG STRANDED WIRE. ② INDICATES 24 AWG STRANDED WIRE. ③ INDICATES 24 AWG 2 LEAD SINGLE SHIELDED CABLE. ④ INDICATES 24 AWG SINGLE SHIELDED WIRE.
4	* INDICATES TO TAPE END TERMINATING POINT.
5	 INDICATES SINGLE SHIELDING  INDICATES DOUBLE SHIELDING
6	FUSE NUMBER. 162360 8/10 AMP SLOW BLOWING.
7	ASSOCIATED CABLE ASSEMBLIES, 321246, 321248, 324154, 324136, 324137.
8	TERMINALS 7 & 9 ARE GROUNDED THRU THE MOUNTING SCREW OF THE TERMINAL STRAPS.
9	
10	INNER SHIELD GROUND NUT ON CONNECTOR MOUNTING.
11	COLOR CODE: BK-BLACK R-RED BL-BLUE O-ORANGE BR-BROWN W-WHITE S-SLATE G-GREEN Y-YELLOW P-PURPLE
12	ASSOCIATED WD 8727 WD SCHEMATIC DIAGRAM.
	NOTES CONTINUED ON SHEET 2

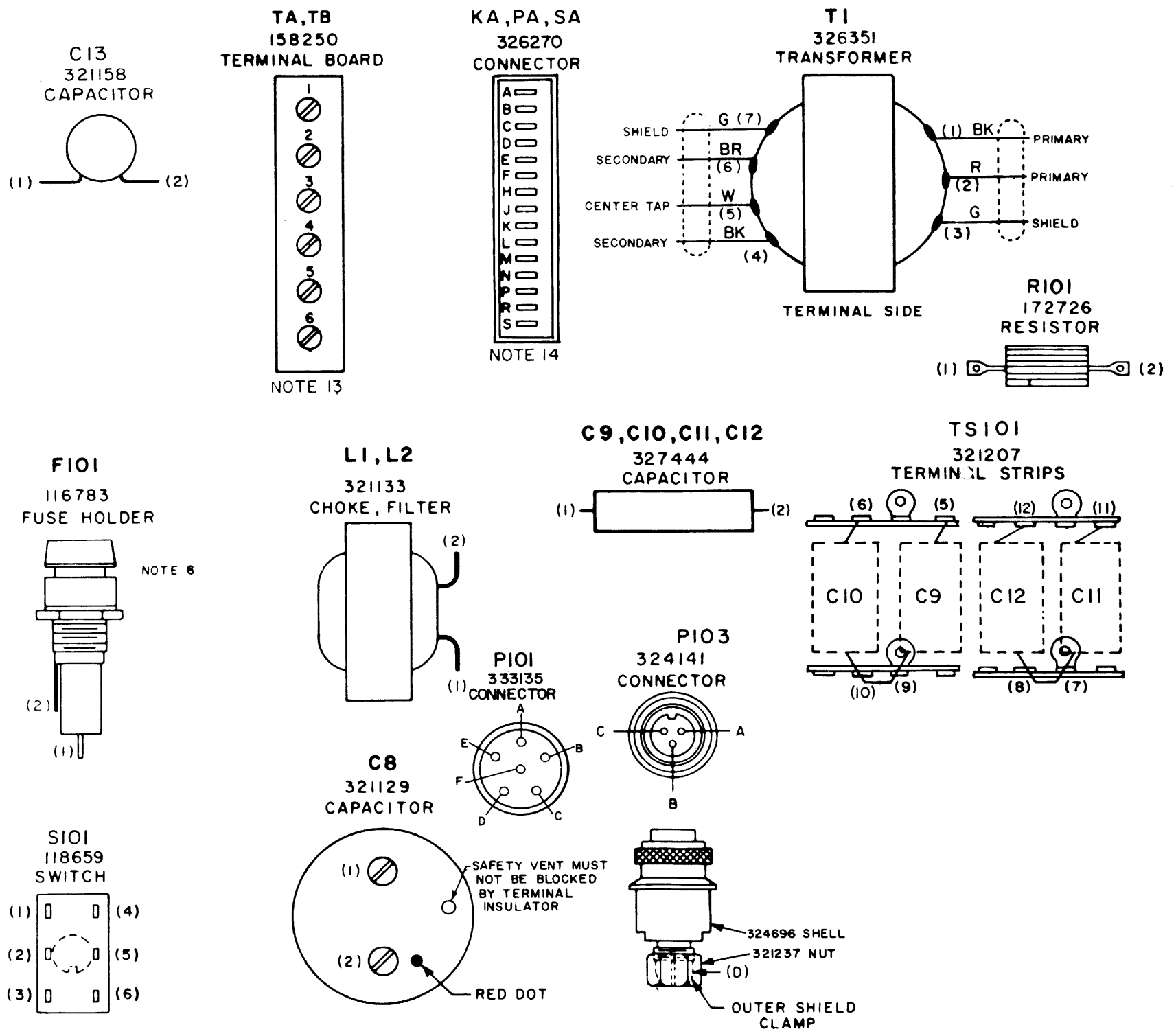

Figure 5-13. Wiring Diagram; Model 28 CPP RO
 ESA 321231 (Sheet 1 of 3)

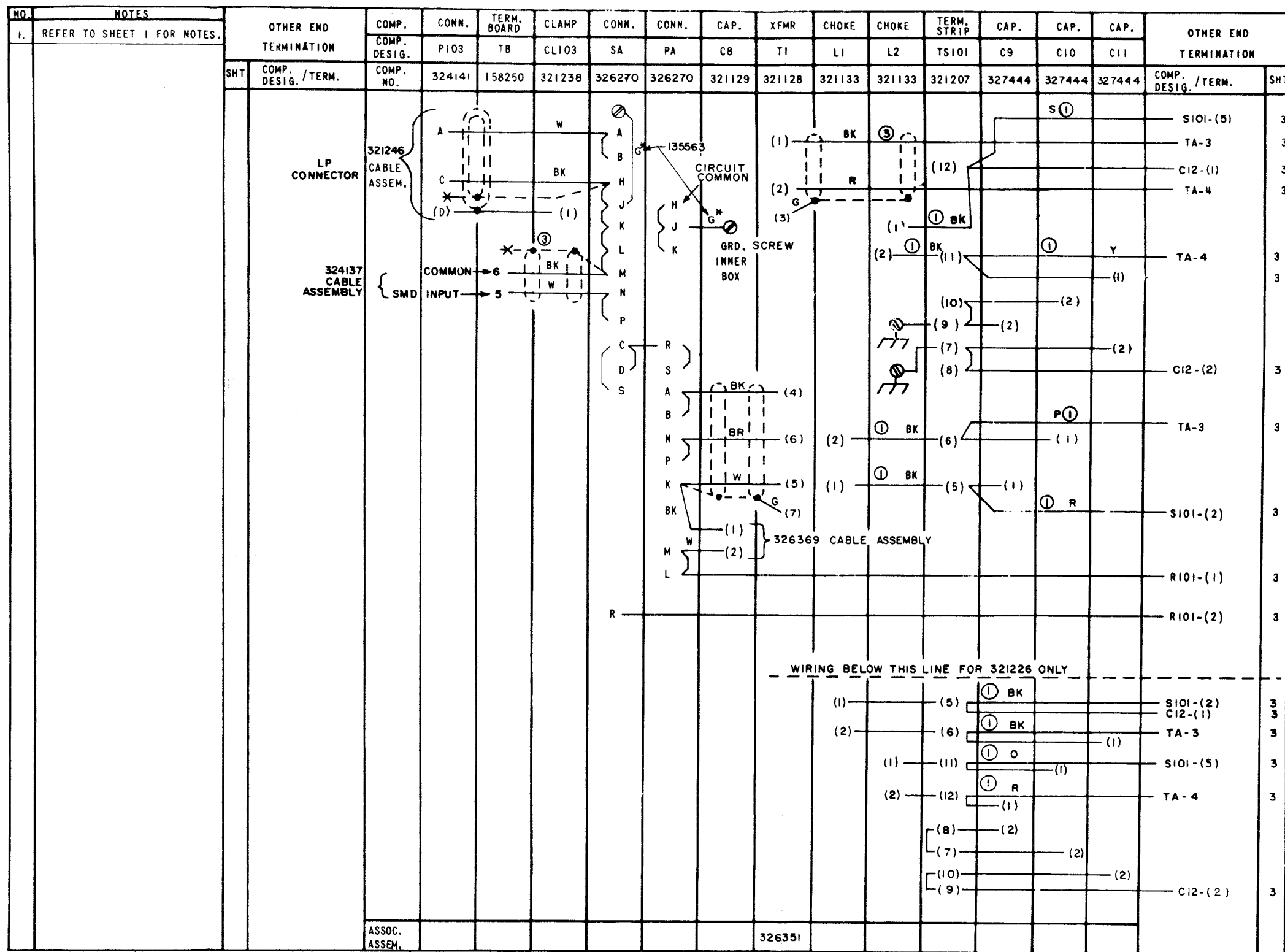

Figure 5-13. Wiring Diagram; Model 28 CPP RO
ESA 321231 (Sheet 2 of 3)

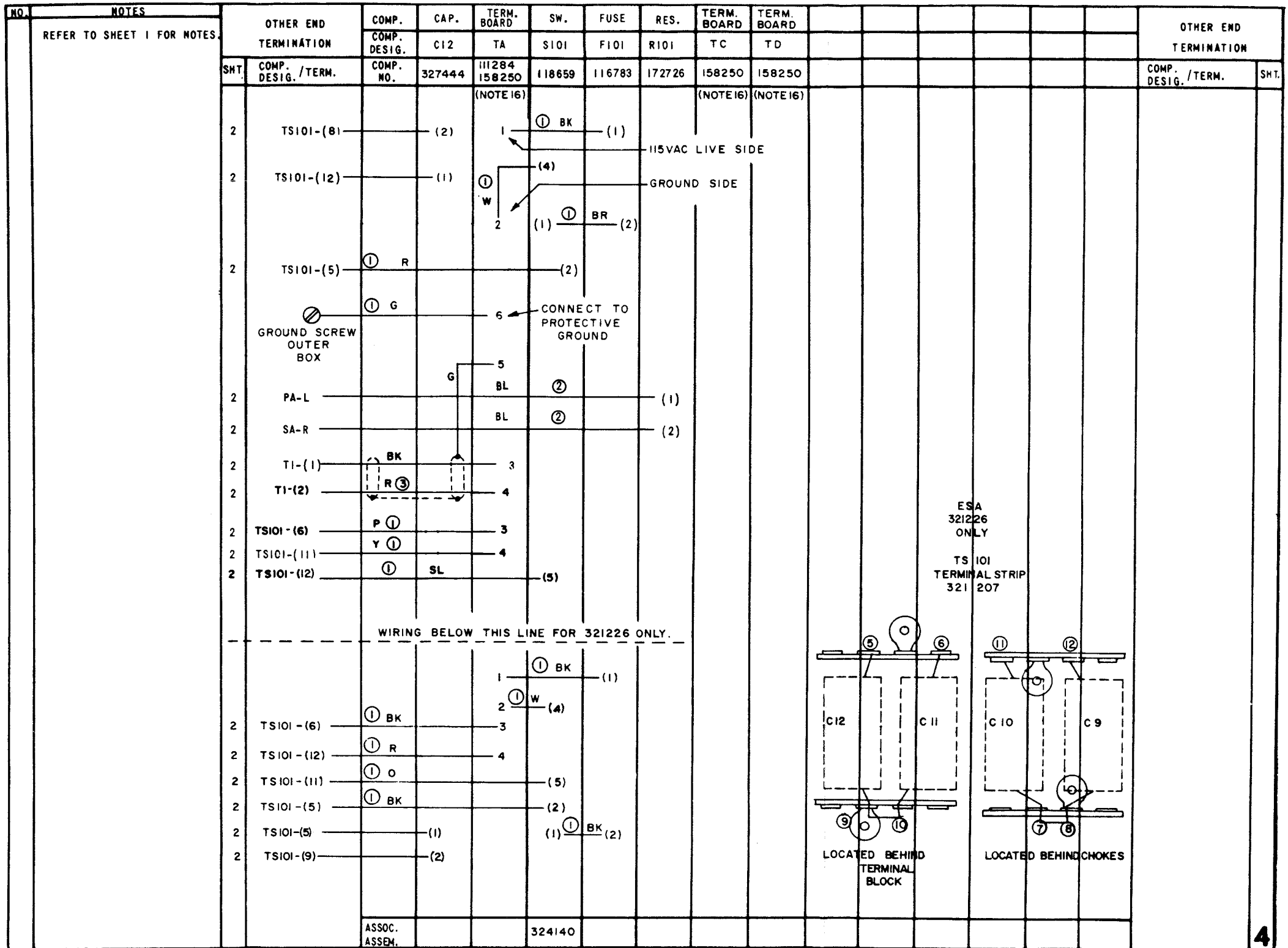

Figure 5-13. Wiring Diagram; Model 28 CPP RO
ESA 321231 (Sheet 3 of 3)

NO	NOTES
1.	--- INDICATES OUTER SHIELD AND - - - - - INDICATES INNER SHIELD
2.	CAPACITANCE VALUES IN MICROFARADS, UNLESS OTHERWISE SPECIFIED.
3.	⊖ INDICATES FEMALE AND ⊕ INDICATES MALE TERMINALS ON CONNECTORS
4.	SL-BL INDICATES SLOW-BLOWING.
5.	⊙ INDICATES SHIELDED WIRE.
6.	ALL VOLTAGES DC, UNLESS OTHERWISE SPECIFIED.
7.	TERMINAL DESIGNATIONS ENCLOSED IN PARENTHESES ARE FOR REFERENCE AND ARE NOT MARKED ON COMPONENT.
8.	WIRING DIAGRAM 9137AD
9.	RESISTANCE VALUES IN OHMS, UNLESS OTHERWISE SPECIFIED.
10.	⊕ DENOTES COMMON RETURN TO CIRCUIT GROUND.
11.	REFERENCE SPEC FOR TELETYPE CORPORATION EMPLOYEES ONLY 61352 S
12.	⊖ INDICATES DOUBLE SHIELDED WIRE

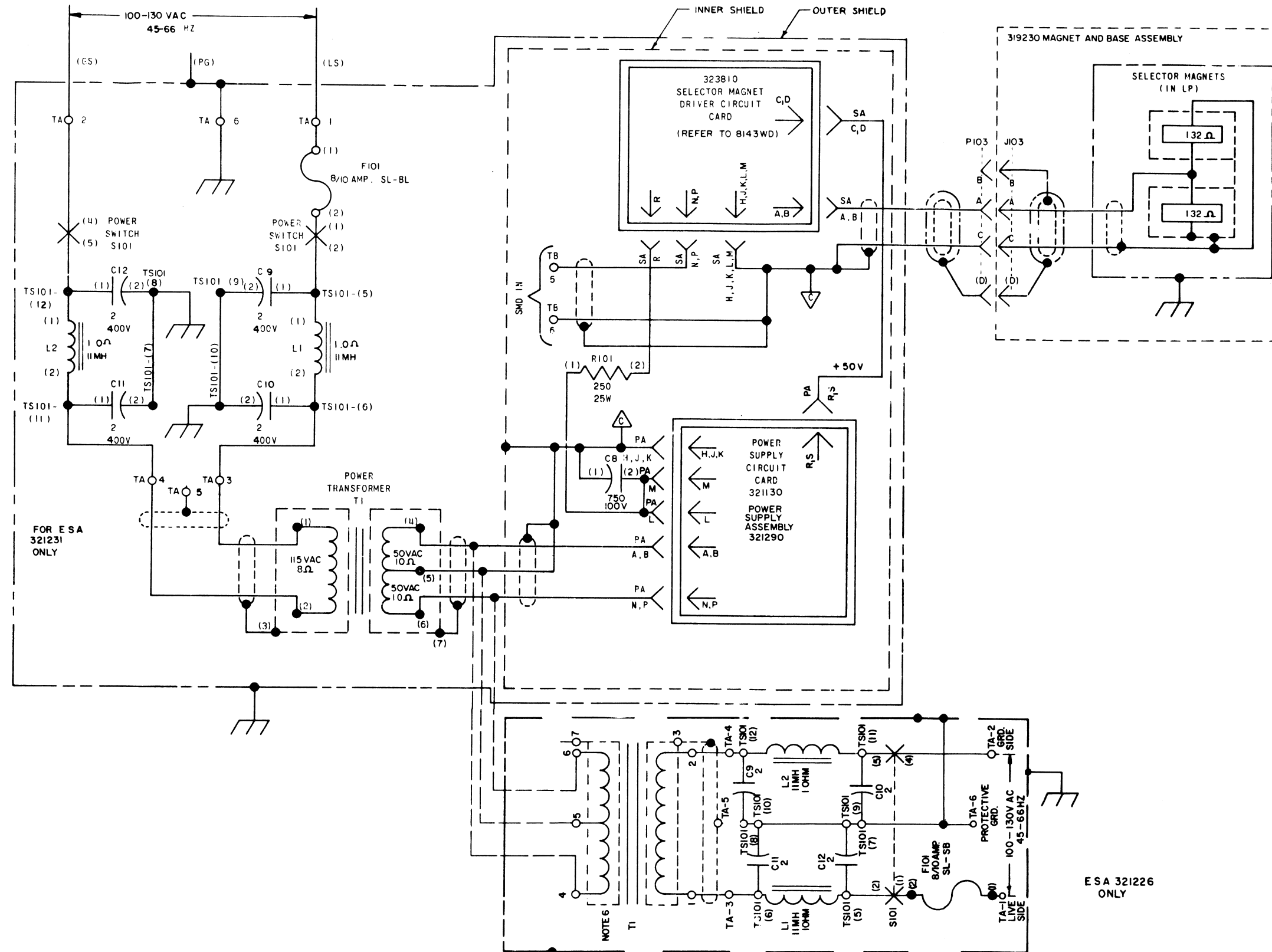
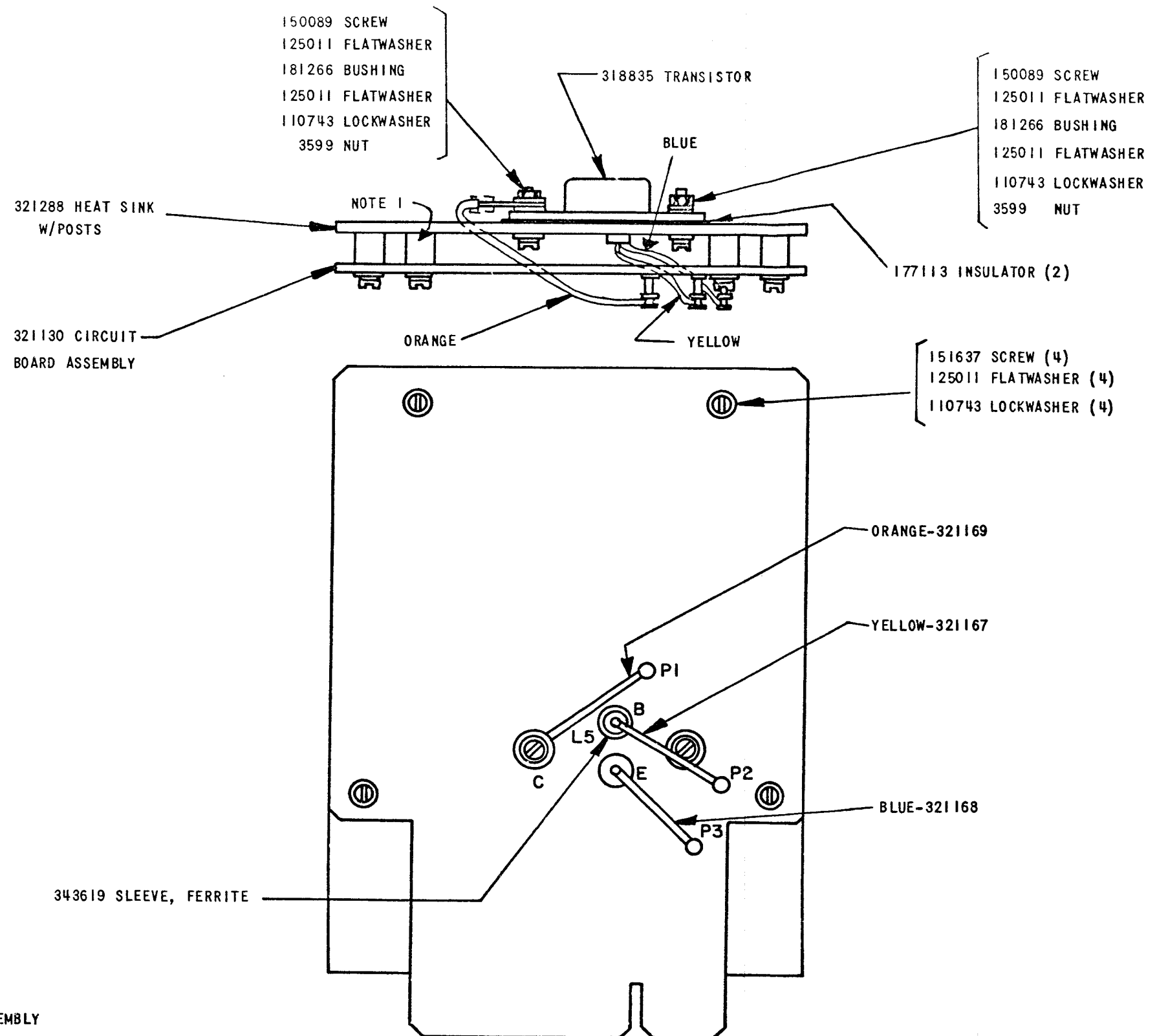

Figure 5-14. Schematic Diagram; Model 28 CPP RO
ESA 321231



NOTE 1

PART NUMBER 321290 TO
BE SCREENED ON HEAT SINK
WITH .250 HIGH CHARACTERS

NOTE 2

THIS ASSEMBLY MUST BE MADE USING THE
HIGHEST CUSTOMER IDENTIFICATION ISSUE
NUMBER OF THE 321130 CIRCUIT CARD ASSEMBLY
EXISTING AT TIME OF ASSEMBLY.

CURRENT CUSTOMER I.D. ISSUE NUMBER IS 13.

Figure 5-15. Assembly Drawing; Model 28 CPP KSR and RO
ESA Power Supply Circuit Board Assembly
with Heat Sink

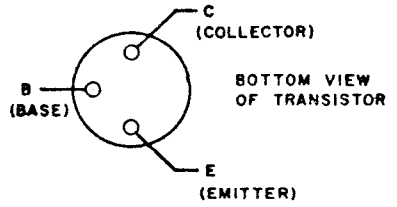
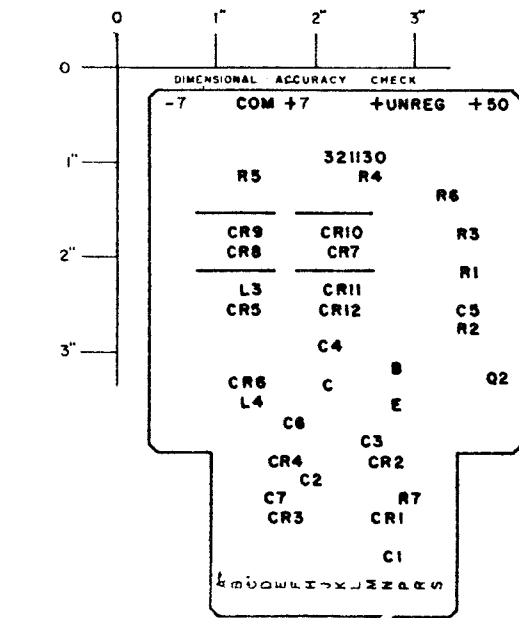
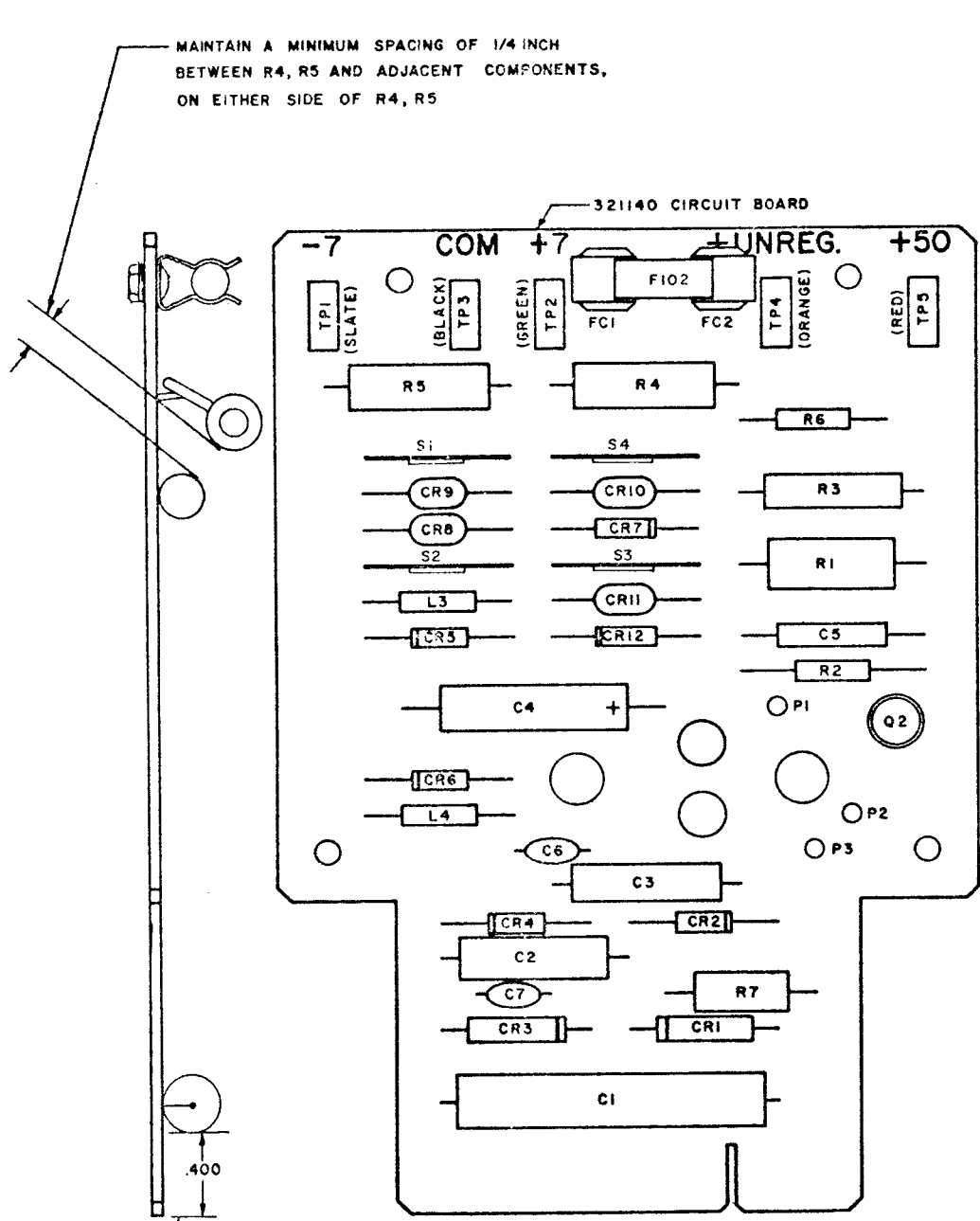

CIRCUIT BOARD ASSEMBLY, POWER SUPPLY (47-53V.D.C. .5AMP. MAX.)				
REF. DESIGN.	PART NO.	TOTAL QTY.	NAME AND DESCRIPTION	FUNCTION
C1	312284	1	CAPACITOR, 15MFD 400V	RF FILTER
C2,3	171535	2	CAPACITOR, .22MFD 200V	RF FILTER
C4	171831	1	CAPACITOR, 10MFD 150V	RECTIFIER FILTER
C5	178860	1	CAPACITOR, .022MFD 100V	RF FILTER
C6,7	312385	2	CAPACITOR, .1MFD 10V	RF FILTER
R1	198937	1	RESISTOR, 2.7K 2W	
R2	192180	2	RESISTOR, 200 OHM 1/2W	
R3	171533	1	RESISTOR 4 OHM 5W	
R4,5	311664	2	RESISTOR, 2.5K 8W	DROPPING
R6			SAME AS R2	RF FILTER
R7	305298	1	RESISTOR, 3.3K 3W	BLEEDER
CR1-4	171541	4	DIODE (NOTE 7)	RECTIFIER
CR5,6	327794	2	DIODE, ZENER (7.2V)	REFERENCE
CR7	321285	2	DIODE, ZENER (1M4749A)	REFERENCE
CR8-11	178844	4	VARIATOR (W.E. 10CA)	REFERENCE
CR12			SAME AS CR7	REFERENCE
L3,4	321159	2	INDUCTOR 39 uH	RF FILTER
Q2	321145	1	TRANSISTOR (2N2270)	GAIN
FC1,2	311068	2	FUSE CLIP	
F102	131807	1	FUSE .5 AMP.	
TP1	320042	1	JACK, TEST (SLATE)	
TP2	320041	1	JACK, TEST (GREEN)	
TP3	320039	1	JACK, TEST (BLACK)	
TP4	320040	1	JACK, TEST (ORANGE)	
TP5	320038	1	JACK, TEST (RED)	
P1-3	137471	3	TERMINAL POST	CONNECTOR
	321140	1	CIRCUIT CARD	
S1-S4	336470	4		
1	151637	2	SCREW 4-40	
2	151880	2	NUT 4-40	
3	110743	2	LOCK WASHER	
4	125011	2	FLAT WASHER	

CIRCUIT DESCRIPTION (SEE SHEET 2)

DIODES CR1 AND CR3 FORM A RECTIFIER WITH ASSOCIATED TRANSFORMER (321123) T1 AND CAPACITOR C8 (321129) TO OBTAIN A MINIMUM +53V DC UNREGULATED. Q1 IS AN EMITTER FOLLOWER VOLTAGE REGULATING ELEMENT WHICH ABSORBS THE VOLTAGE DIFFERENCE BETWEEN THE UNREGULATED DC AND THE CONSTANT +50V DC REFERENCE ESTABLISHED BY DIODES CR7-CR12. Q2 PROVIDES GAIN FOR Q1. DIODES CR3, CR4, TRANSFORMER T1 AND CAPACITOR C4 FORM A FULL WAVE RECTIFIER TO OBTAIN NEGATIVE UNREGULATED DC. R4 AND CR6, R5 AND CR5 FORM BASIC SHUNT REGULATORS TO OBTAIN +7 AND -7V DC.

- 1) TELETYPE REFERENCE ONLY: SPECIFICATION 61,267S
- 2) SEE SHEET 2 FOR SCHEMATIC WIRING
- 3) ALL CHARACTERS TO BE .125 HIGH AND PRINTED WITH WHITE ENAMEL.
- 4) ALL PRINTED CHARACTERS TO BE LOCATED ±.031 FROM NOMINAL POSITION.
- 5) L5 ADDED TO SCHEMATIC AT DRAWING ISSUE 14
- 6) ANY REVISION OF CUSTOMER IDENTIFICATION NUMBER MUST BE REFLECTED IN NOTE 2 ON DRAWING OF 321290 CIRCUIT CARD ASSEMBLY WITH HEAT SINK.
- 7) CR1-4 - 192520 (1N4383) WAS REPLACED FOR STANDARDIZATION

MOUNT C1 CAPACITOR ON END SO THAT THERE IS A MINIMUM OF .400 CLEARANCE TO BOTTOM OF BOARD.

Figure 5-16. Circuit Board Assembly; Model 28 CPP KSR and RO ESA Power Supply (47 - 53 VDC, 0.5 Amp Max) (Sheet 1 of 2)

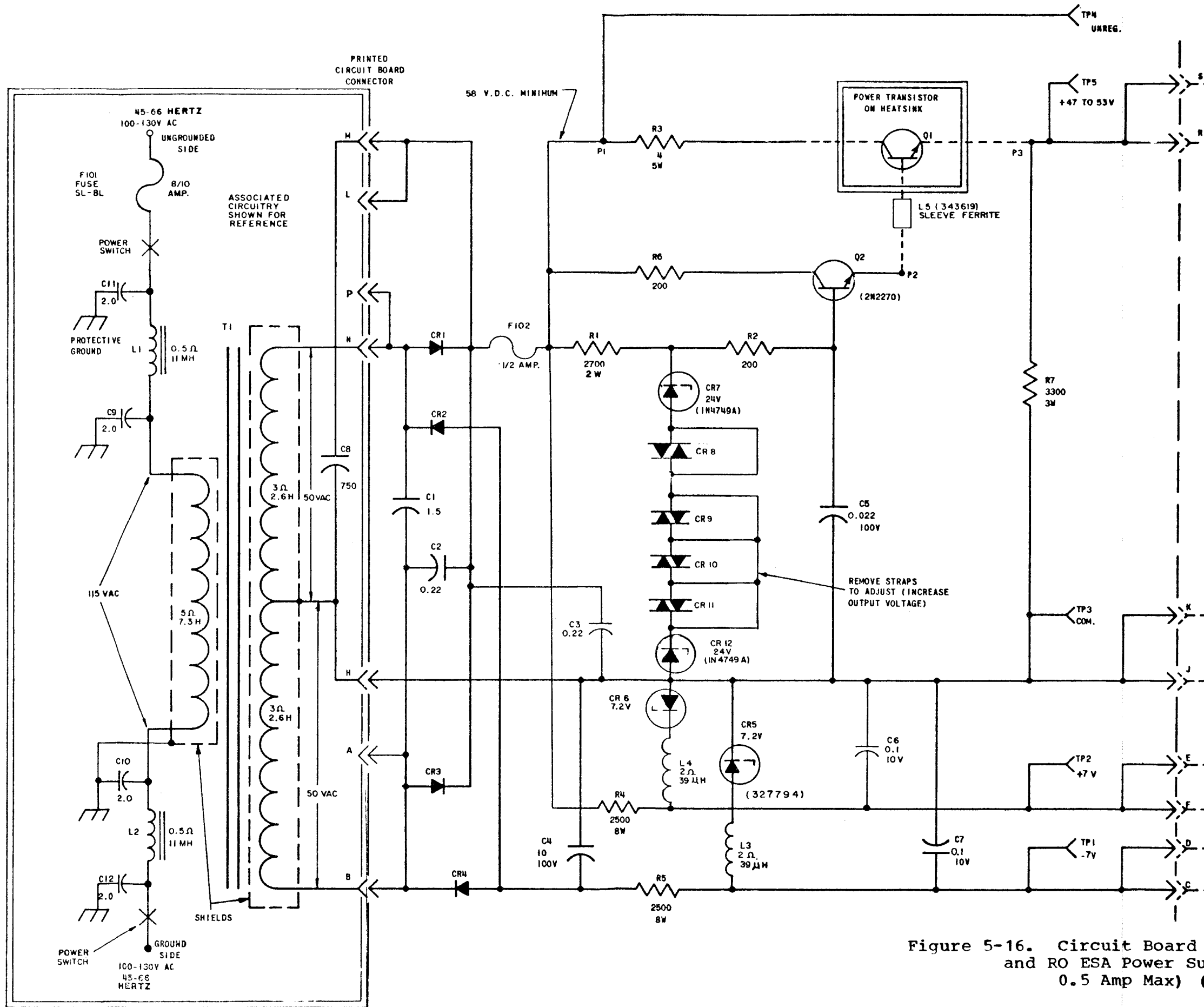
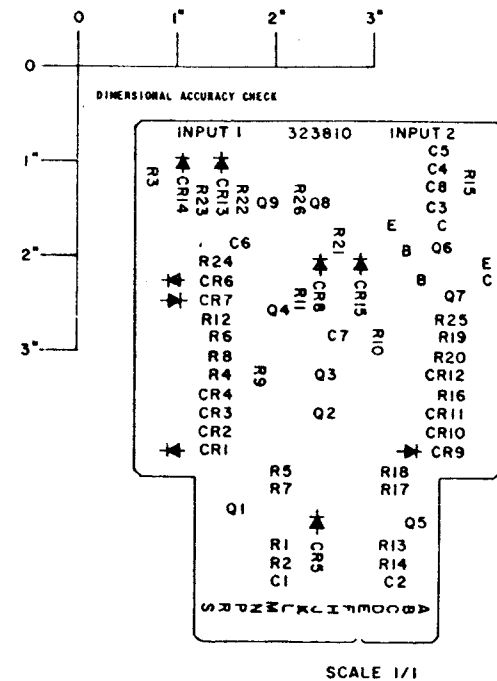
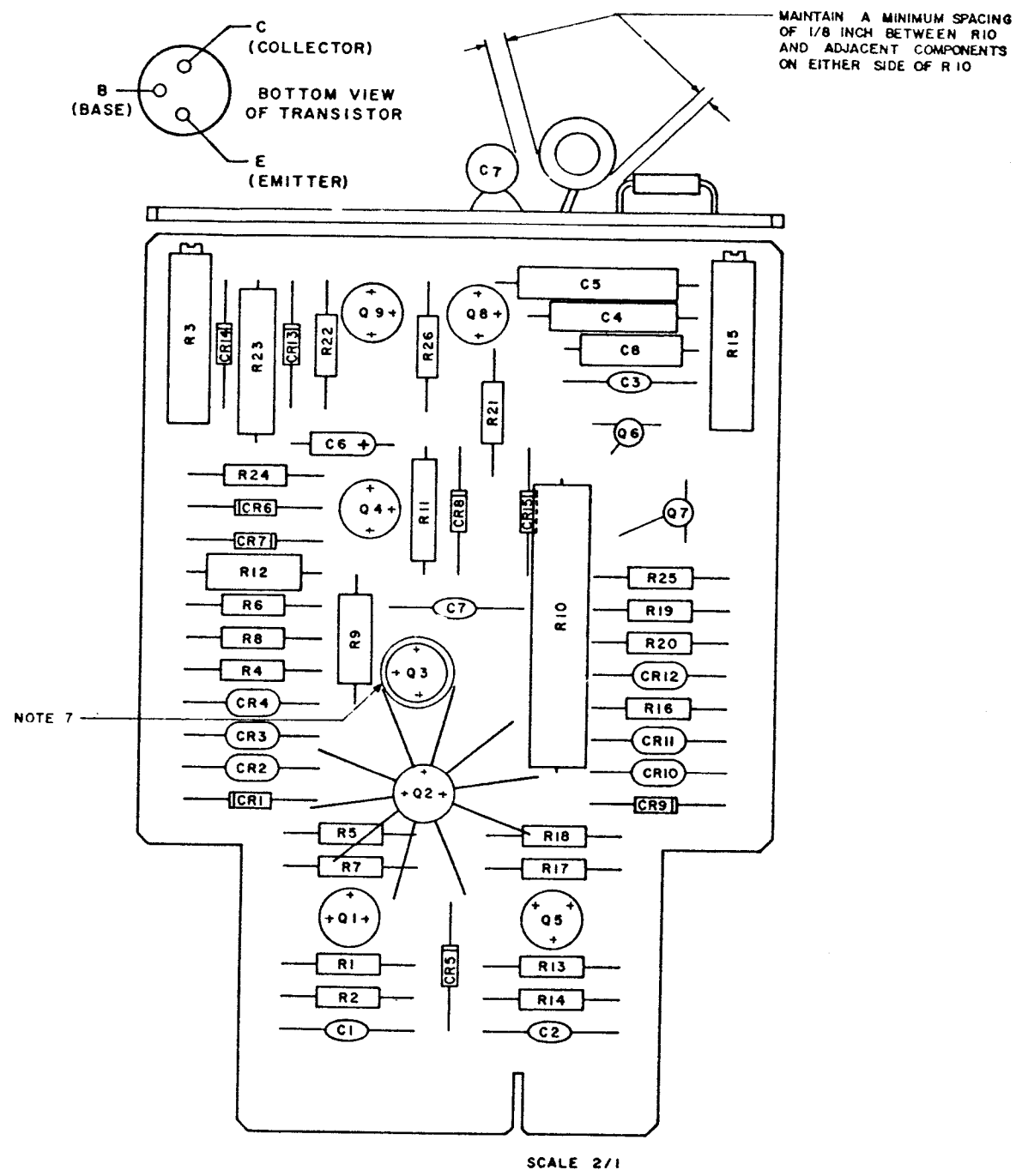

Figure 5-16. Circuit Board Assembly; Model 28 CPP KSR and RO ESA Power Supply (47 - 53 VDC, 0.5 Amp Max) (Sheet 2 of 2)

REF. DESIG.	TELETYPE PART NO.	TOTAL QTY.	NAME AND DESCRIPTION	LOCATING FUNCTION
C1	321157	1	CAPACITOR, 500 pF	R.F. BY-PASS CAP.
C2	321157	1	CAPACITOR, 500 pF	R.F. BY-PASS CAP.
C3	321157	1	CAPACITOR, 500 pF	R.F. BY-PASS CAP.
C4	171829	1	CAPACITOR, .15 MFD	Q8 FEEDBACK CAP.
C5	326776	1	CAPACITOR, .47 MFD	Q9 FEEDBACK CAP.
C6	321260	1	CAPACITOR, 1 MFD 50V	TRANSIENT SUPP.
C7	321157	1	CAPACITOR, 500 pF	R.F. BY-PASS CAP.
C8	178860	1	CAPACITOR, .022 MFD	R.F. BY-PASS CAP.
R1	118720	1	RESISTOR, 100K, 1/2W	Q1 OPEN LINE BIAS
R2	118720	1	RESISTOR, 100K, 1/2W	INPUT 1 RES
R3	323944	1	POTENTIOMETER 500K	Q1 BIAS
R4	129854	1	RESISTOR, 10K, 1/2W	Q1 BIAS
R5	118177	1	RESISTOR, 22K, 1/2W	Q1 LOAD RES.
R6	137604	1	RESISTOR, 620, 1/2W	VOLTAGE DIVIDER
R7	118146	1	RESISTOR, 4.7K, 1/2W	Q1 EMITTER RES.
R8	129850	1	RESISTOR, 680, 1/2W	VOLTAGE DIVIDER
R9	309866	1	RESISTOR, 1.3K, 3W	CR5 CURRENT LIMITER
R10	323841	1	RESISTOR, 300, 12 W	Q2 LOAD RES.
R11	323842	1	RESISTOR, 21, 1/2W, 1% REG. CURRENT SET	
R12	178864	1	RESISTOR, 3.9K, 1W CR8 CURRENT LIMITER	
R13	118720	1	RESISTOR, 100K 1/2W	Q5 OPENLINE BIAS
R14	118720	1	RESISTOR, 100K, 1/2W	INPUT 2 RES.
R15	323944	1	POTENTIOMETER 500K	Q5 BIAS
R16	129854	1	RESISTOR, 10K, 1/2W	Q5 BIAS
R17	118177	1	RESISTOR, 22K, 1/2W	Q5 LOAD RES.
R18	118146	1	RESISTOR, 4.7K, 1/2W	Q5 EMITTER RES.
R19	137604	1	RESISTOR, 620, 1/2W	VOLTAGE DIVIDER
R20	129850	1	RESISTOR, 680, 1/2W	VOLTAGE DIVIDER
R21	321975	1	RESISTOR, 33, 1/2W	Q8 EMITTER RES.
R22	118177	1	RESISTOR, 22K, 1/2W	CR13 BIAS RES.
R23	323843	1	RESISTOR, 590, 5W, 1% COIL CURRENT LIMITER	
R24	137442	1	RESISTOR, 1.5K, 1/2W	C6 BLEEDER RES.
R25	118154	1	RESISTOR 47K, 1/2W	Q6, Q7 LOAD RES.
R26	120424	1	RESISTOR 4.3K, 1W	Q8 LOAD RES.
CR1	197464	7	DIODE, NOTE 9	Q1 BASE PROT.
CR2	178844	1	VARIATOR, 100-A	TEMP. COMP.
CR3	178844	1	VARIATOR, 100-A	TEMP. COMP.
CR4	178844	1	VARIATOR, 100-A	TEMP. COMP.
CR5	181667	1	DIODE, 1N750A	TEMP. COMP. REF.
CR6			SAME AS CR1	Q4 COLLECTOR CLAMP
CR7			" " "	Q4 COLLECTOR CLAMP
CR8	321181	1	DIODE, 1N748A	REG. VOLT REF.
CR9			SAME AS CR1	Q5 BASE PROT.
CR10	178844	1	VARIATOR, 100-A	TEMP. COMP.
CR11	178844	1	VARIATOR, 100-A	TEMP. COMP.
CR12	178844	1	VARIATOR, 100-A	TEMP. COMP.
CR13			SAME AS CR1	Q3 EMITTER DIODE
CR14			" " "	TRANSIENT SUPP.
CR15			" " "	Q8 EMITTER DIODE
Q1	321166	1	TRANSISTOR, 2N1893	DC AMP.
Q2	323844	1	TRANSISTOR, 2N3053	SHUNT REG.
Q3	321261	1	TRANSISTOR, 2N4036	SHUNT REG. AMP.
Q4	323845	1	TRANSISTOR, 40319	SERIES REG.
Q5	321166	1	TRANSISTOR, 2N1893	DC AMP.
Q6	324144	2	TRANSISTOR, 2N4121	DC AMP.
Q7			SAME AS Q6	
Q8	321185	1	TRANSISTOR, 2N3638A	DC AMP.
Q9	321281	1	TRANSISTOR, 2N4036	DC AMP.
	324147	2	PAD, TRANSISTOR	
	144495	6	PAD, TRANSISTOR	
	323846	1	PAD, TRANSISTOR	
	323847	1	HEAT SINK	
	323835	1	CIRCUIT BOARD, ETCHED	
	300116	1	COVER, INSULATING	

USED ON 323808.



- NOTES:
1. TRANSISTOR Q2 HAS 323847 HEAT SINK PRESSED ON.
 2. USE 323846 TRANSISTOR PAD UNDER TRANSISTOR Q3.
 3. REFERENCE SPECIFICATION FOR TELETYPE CORP. EMPLOYEES ONLY: 61,2645
 4. REFER TO 8143WD FOR SCHEMATIC WIRING DIAGRAM.
 5. ALL CHARACTERS TO BE .125 HIGH AND PRINTED WITH WHITE ENAMEL.
 6. ALL PRINTED CHARACTERS TO BE LOCATED +.031 FROM NOMINAL.
 7. Q3 HAS 300116 INSULATING COVER. POSITION Q3 (WITH COVER) SO THAT 323847 HEAT SINK MAY BE FULLY SEATED ON Q2.
 8. 144495 TRANSISTOR PAD REQUIRED ON Q1, Q4, Q5, Q8 AND Q9, AND Q2.
 9. PARTS CHANGED FOR STANDARDIZATION WERE FORMERLY AS FOLLOWS: CR1, CR9, CR14 — 321154 (1N457A) AND CR6, CR7, CR13, CR15 — 321156 (1N482A).

Figure 5-17. Circuit Board Assembly; Model 28 CPP KSR and RO ESA SMD with Signal Combiner

NO.	NOTES
1.	R3 AND R15 ARE ADJUSTED FOR SYMMETRICAL SWITCHING ABOUT ZERO VOLTS FOR INPUT 1 AND 2 RESPECTIVELY
2.	PINS A, B - 60MA TO COILS PINS C, D - 47 TO 53V DC POWER INPUT PINS G, H - MS 188B SIGNAL INPUT 1 PINS I, J - MS 188B SIGNAL INPUT 2 PINS K, L, M - CIRCUIT COMMON (ALL INPUTS AND OUTPUTS REFERRED TO CIRCUIT COMMON).
3.	REFERENCE SPEC. FOR TELETYPE CORP. EMPLOYEES ONLY: 61,264S.
4.	ALL RESISTORS ARE 5%, 1/2 WATT UNLESS OTHERWISE SPECIFIED.
5.	ALL CAPACITANCE VALUES IN PICO FARADS UNLESS OTHERWISE SPECIFIED.
6.	∇ DENOTES CIRCUIT COMMON.

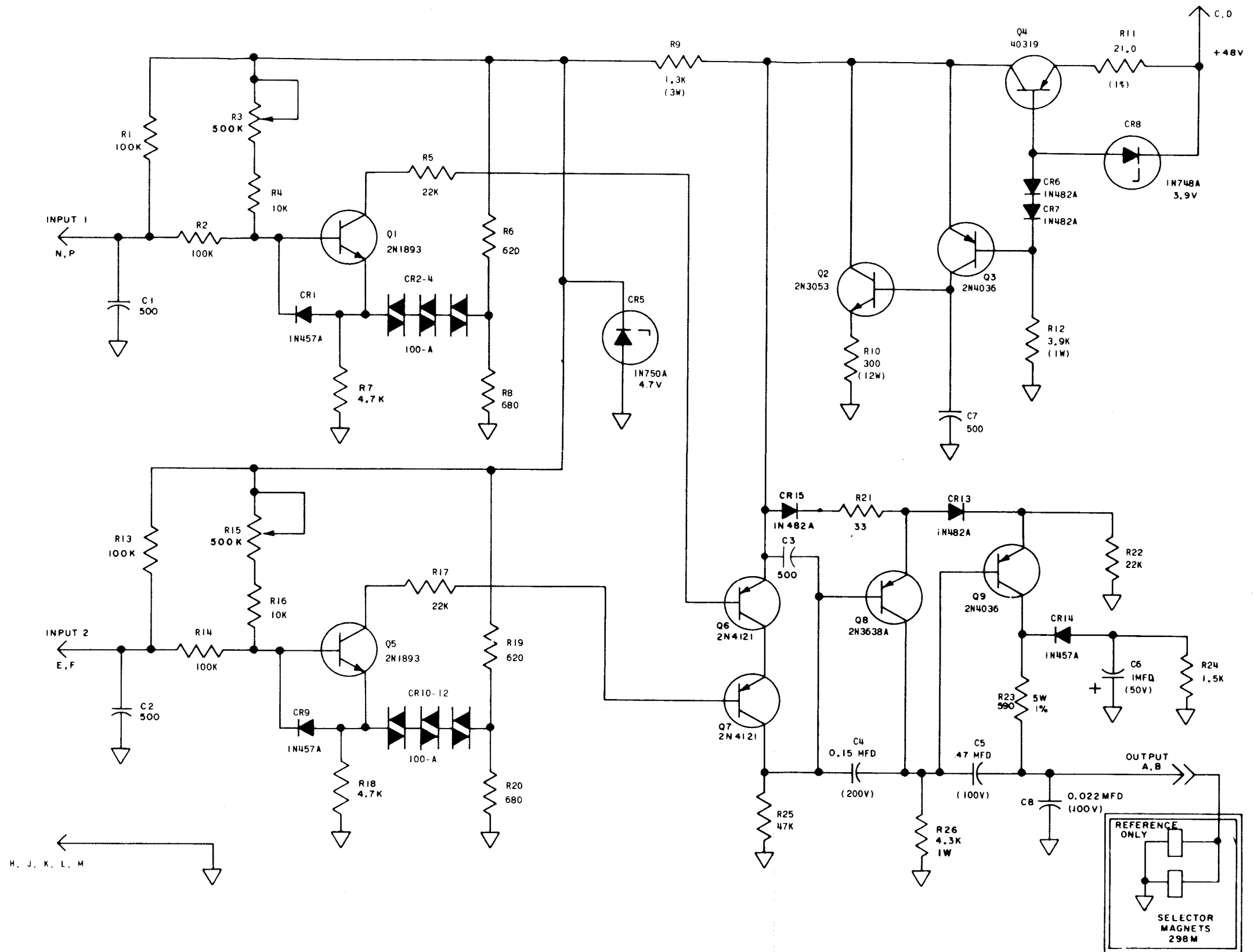



Figure 5-18. Schematic Diagram; Model 28 CPP KSR and RO ESA SMD with Signal Combiner, 323810

NO.	NOTES
1.	ALL VOLTAGES DC UNLESS OTHERWISE SPECIFIED.
2.	TERMINAL DESIGNATION ENCLOSED IN PARENTHESIS ARE FOR REFERENCE AND ARE NOT MARKED ON COMPONENT.
3.	FUSE NUMBER-162360 8/10 AMP SLOW BLOWING
4.	TERMINALS 7 AND 9 ARE CONNECTED TO THE OUTER SHIELD THRU THE MOUNTING SCREWS
5.	* INDICATES TO TAPE END TERMINATING POINT.
6.	 INDICATES SINGLE SHIELDING
7.	 INDICATES DOUBLE SHIELDING
8.	ALL STRAPPING WIRE 24 AWG. BARE, 39603RM USE SLEEVING WHERE REQUIRED. ① INDICATES 18 AWG STRANDED WIRE. ② INDICATES 24 AWG STRANDED WIRE. ③ INDICATES 24 AWG 2 LEAD SINGLE SHIELDED CABLE. ALL SURFACE WIRE 24 AWG GREEN, 31784 RM, UNLESS OTHERWISE SPECIFIED.
9.	REFER TO 8725WD FOR SCHEMATIC WIRING DIAGRAM
10.	COLOR CODE BK- BLACK G- GREEN BR- BROWN O- ORANGE BL- BLUE P- PURPLE R - RED Y- YELLOW S - SLATE W- WHITE
11.	OUTER SHIELD CONNECTED TO BOX AT CONNECTOR.

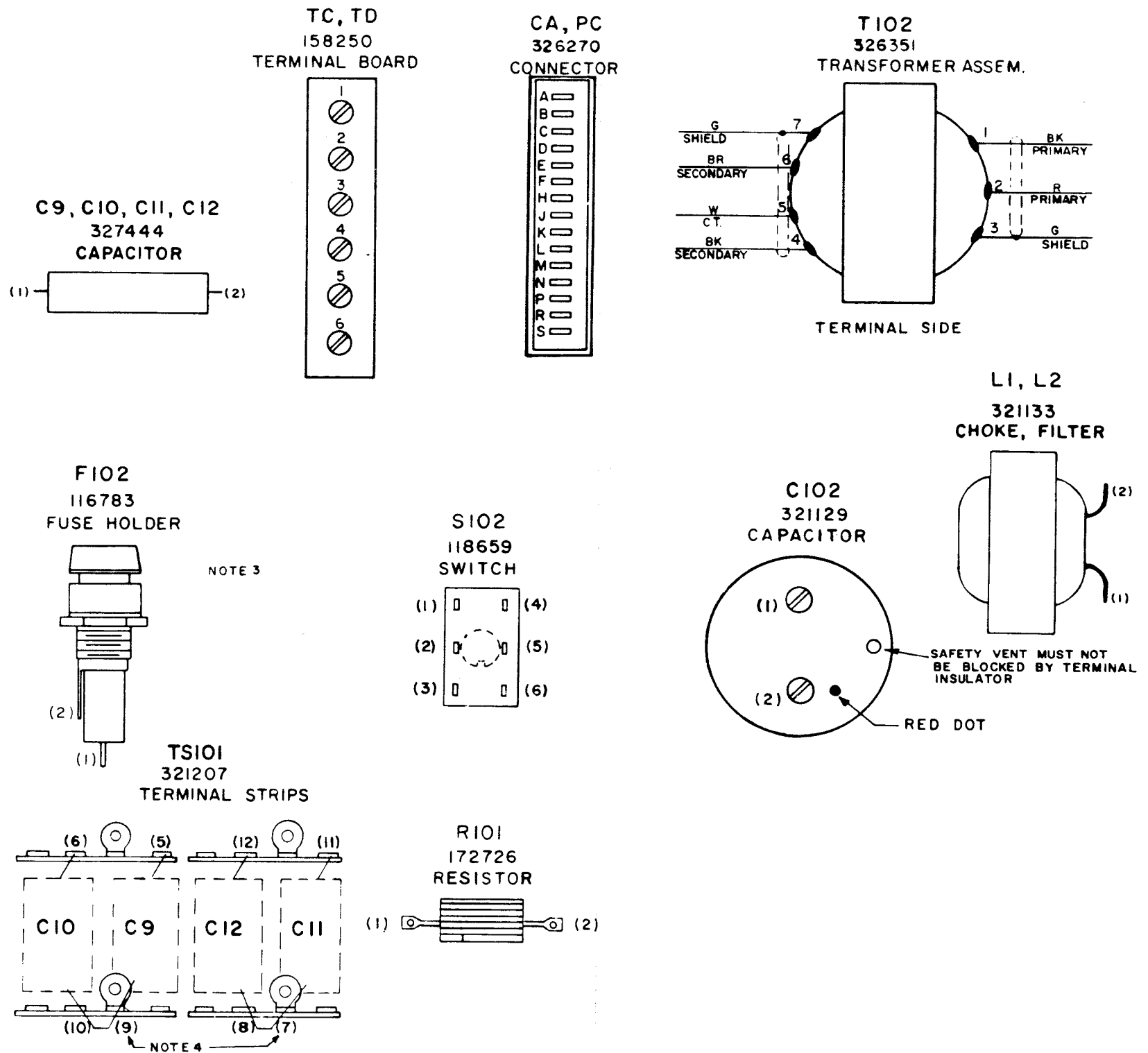

Figure 5-19. Wiring Diagram; Model 28 CPP KSR ESA 323120 (CMD) (Sheet 1 of 4)

NO.	NOTES
1.	SEE SHEET 1 FOR NOTES.

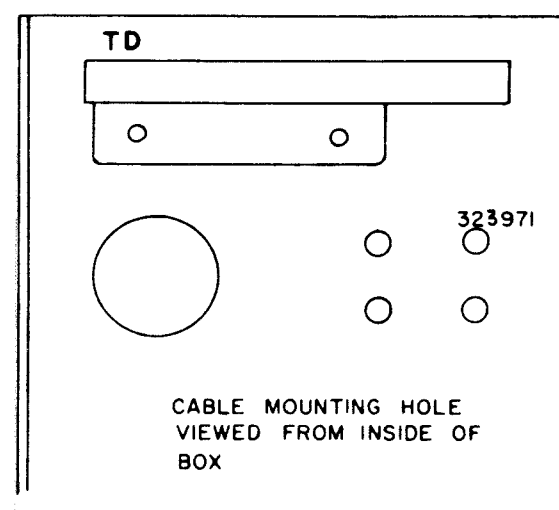
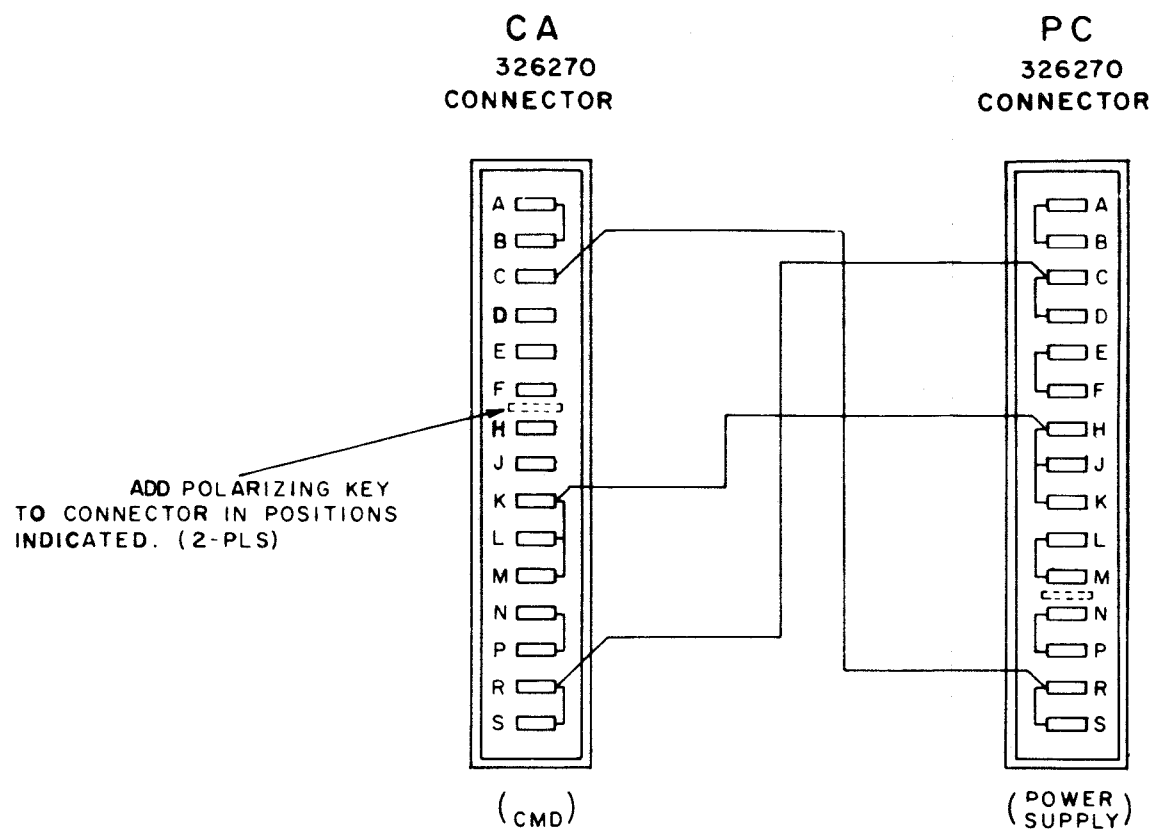

Figure 5-19. Wiring Diagram; Model 28 CPP KSR ESA 323120 (CMD) (Sheet 2 of 4)

NO.	NOTES
I.	SEE SHEET I FOR NOTES.

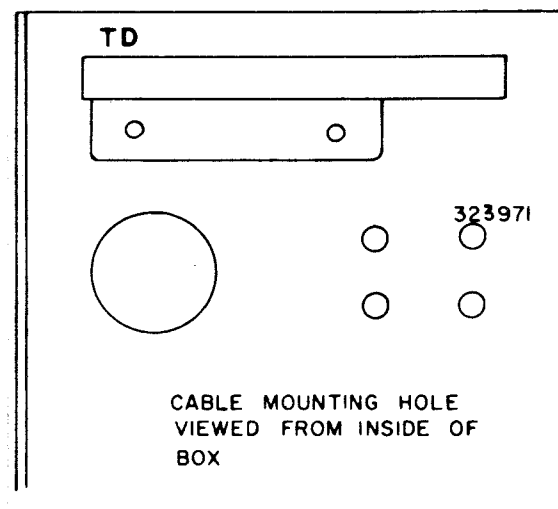
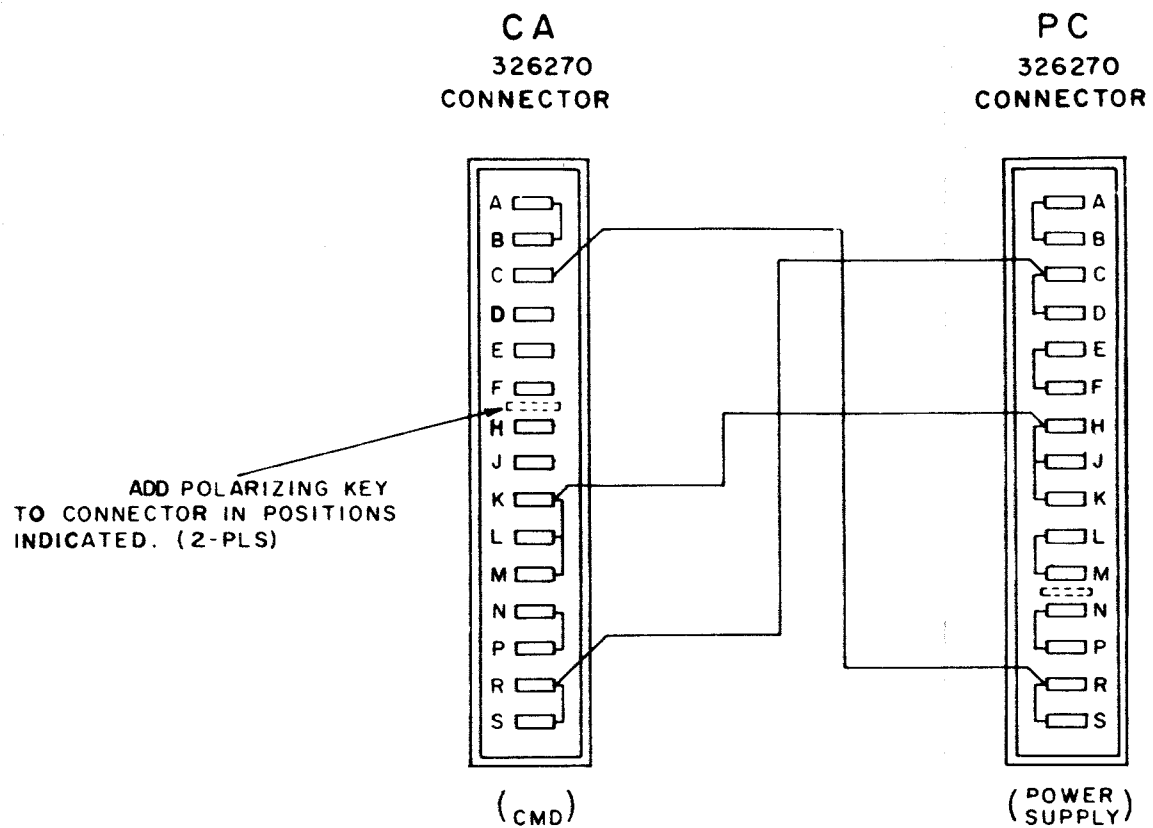

Figure 5-19. Wiring Diagram; Model 28 CPP KSR ESA 323120 (CMD) (Sheet 2 of 4)

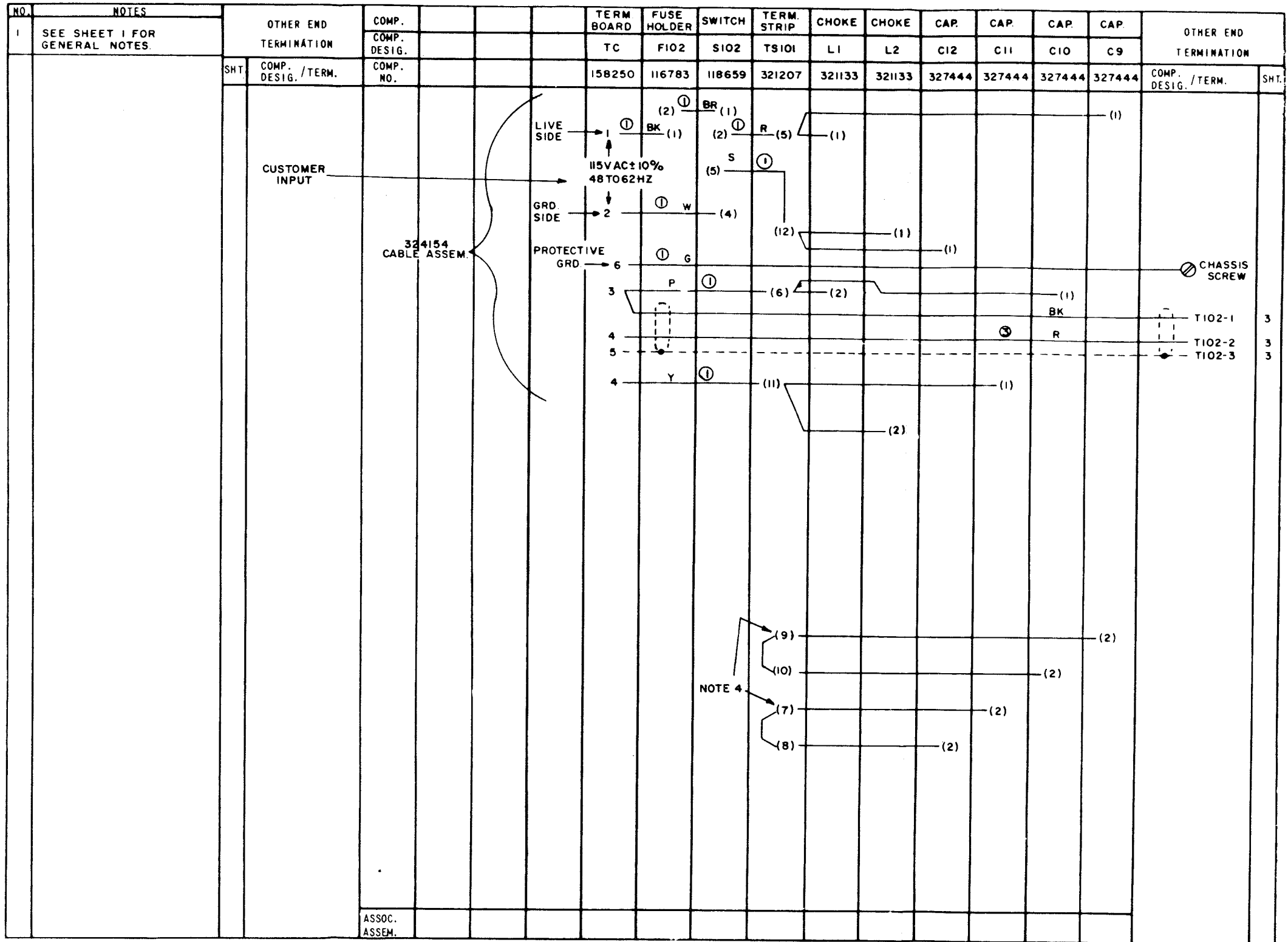







Figure 5-19. Wiring Diagram; Model 28 CPP KSR ESA 323120 (CMD) (Sheet 4 of 4)

NO.	NOTES
1.	ALL RESISTORS 1/2 WATT, RESISTANCE VALUES IN OHMS, CAPACITANCE VALUES IN MICROFARADS UNLESS OTHERWISE SPECIFIED.
2.	 INDICATES FEMALE TERMINAL  INDICATES MALE TERMINAL
3.	 INDICATES SINGLE SHIELDING  INDICATES DOUBLE SHIELDING
4.	REFER TO 8724WD FOR ACTUAL WIRING DIAGRAM.
5.	SL-BL INDICATES SLOW-BLOWING.
6.	 INDICATES CIRCUIT COMMON
7.	S-NUMBER 61,598
8.	TERMINAL DESIGNATIONS ENCLOSED IN PARENTHESIS ARE FOR REFERENCE AND ARE NOT MARKED ON COMPONENT.
9.	REFER TO RELATED SET SCHEMATIC 8729WD FOR EXTERNAL CIRCUITS.
10.	8 OHMS (MAX.) PRIMARY RESISTANCE 10 OHMS (MAX.) SECONDARY RESISTANCE TO CENTER TAP.

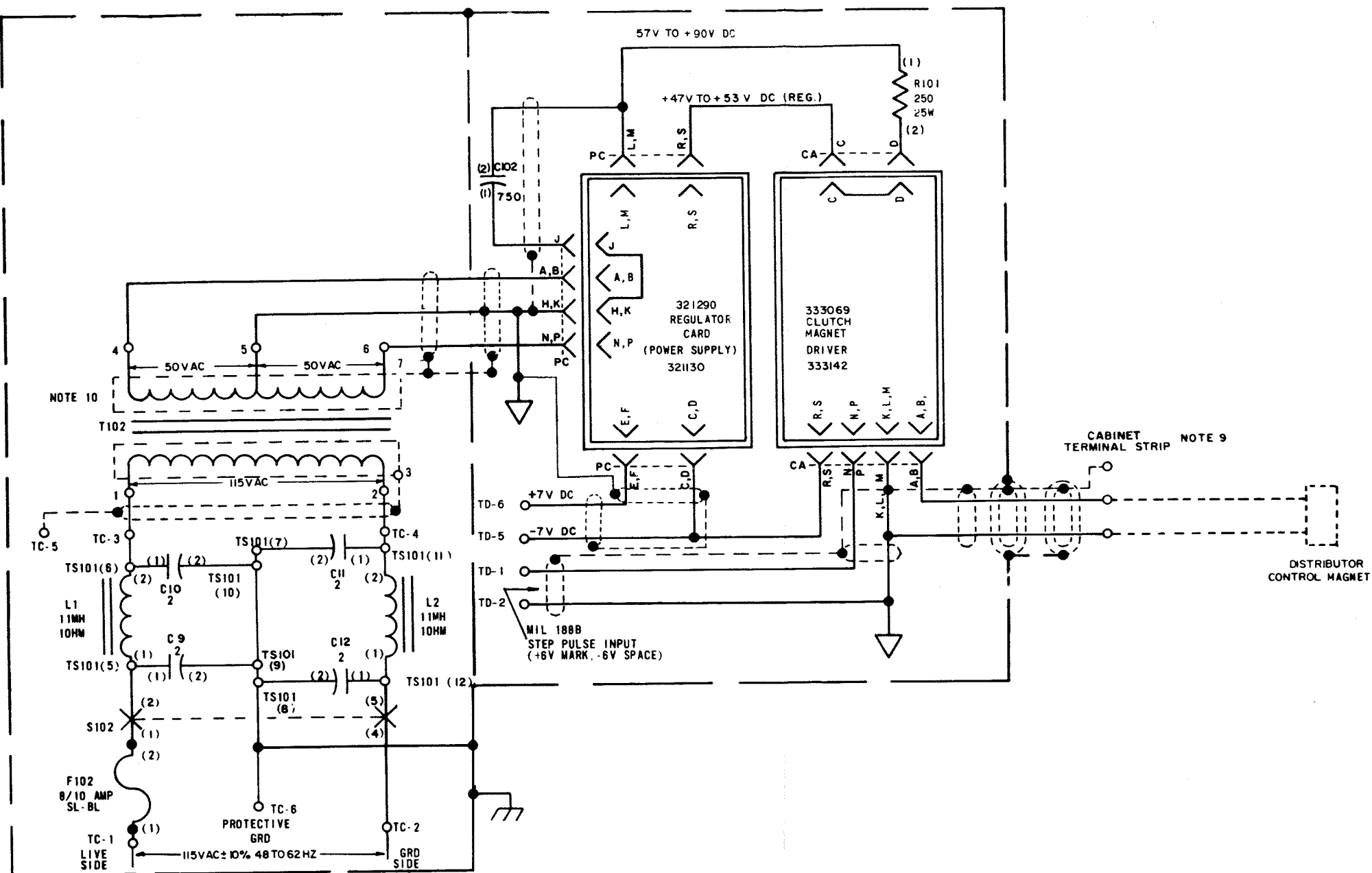

Figure 5-20. Schematic Diagram; Model 28 CPP KSR ESA 323120 (CMD)

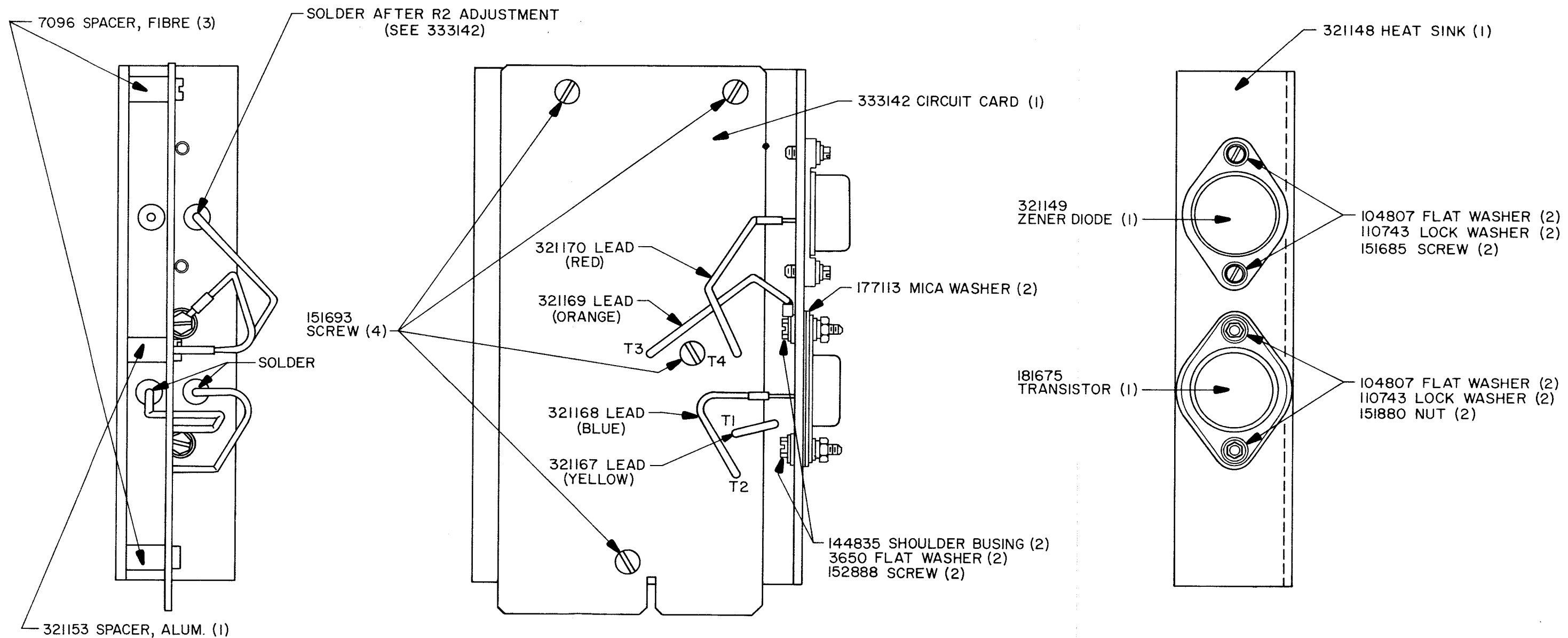
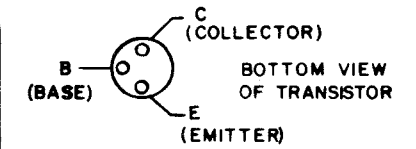
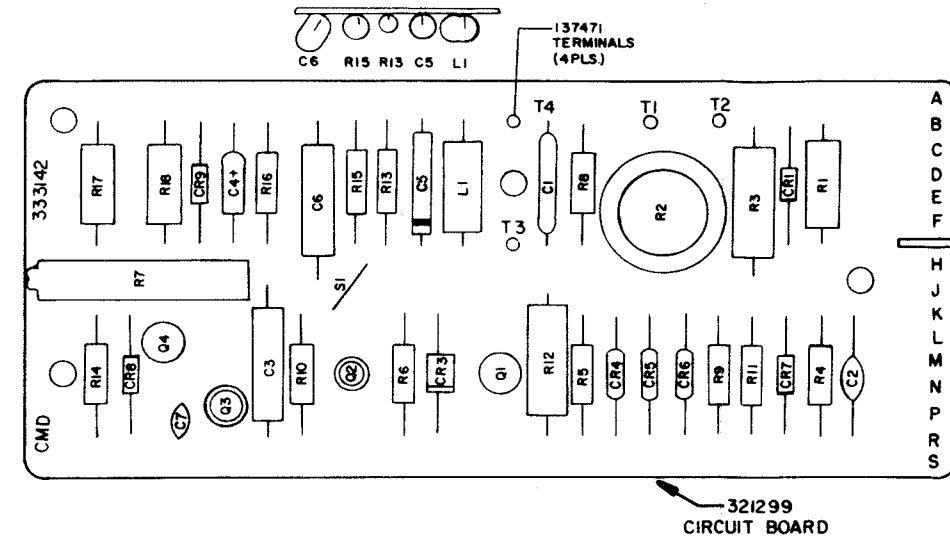
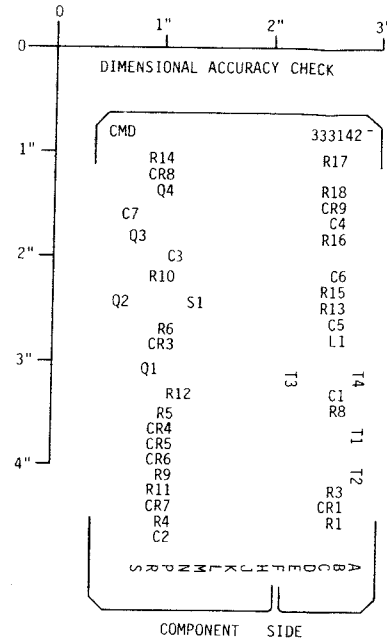

Figure 5-21. Assembly Drawing; Model 28 CPP KSR ESA
CMD Circuit Board Assembly with Heat Sink

NOTES:

1. THIS VIEW MAY BE USED AS 1-TO-1 MASTER FOR ARTWORK.
2. ALL CHARACTERS TO BE 0.125 IN. HIGH AND PRINTED WITH WHITE ENAMEL.
3. ALL PRINTED CHARACTERS TO BE LOCATED +0.031 IN. FROM POSITION SHOWN IN VIEW.

REF. DESIG.	TELETYPE PART NO.	TOTAL QTY	NAME AND DESCRIPTION	LOCATING FUNCTION
R1	329275	1	RESISTOR, 35 OHM, 1W, +1%	REG. CURRENT LIMITER
R2	182773	1	POTENTIOMETER, 300HM, 2.5W	REG. CURRENT ADJ.
R3	32115	1	RESISTOR, 2K, 2W, 5%	CR1 CURRENT LIMITER
R4	118720	1	RESISTOR, 100K, 1/2W, 5%	Q1 OPEN LINE BIAS
R5	118720	1	RESISTOR, 100K, 1/2W, 5%	INPUT RESISTOR
R6	129854	1	RESISTOR, 10K, 1/2W	Q1 BIAS
R7	321160	1	POTENTIOMETER, 5M	Q1 BIAS
R8	118146	1	RESISTOR, 4.7K, 1/2W, 5%	Q1 EMITTER RES
R9	129850	1	RESISTOR, 680 OHM, 1/2W, 5%	VOLTAGE DIVIDER
R10	321258	1	RESISTOR, 20K, 1/2W, 5%	Q1 LOAD RES
R11	137604	1	RESISTOR, 620 OHM, 1/2W, 5%	VOLTAGE DIVIDER
R12	321292	1	RESISTOR, 1.3K, 2W, 5%	CR7 CURRENT LIMITER
R13	139143	1	RESISTOR, 43K, 1/2W, 5%	Q2 LOAD RES
R14	321259	1	RESISTOR, 15 OHM, 1/2W, 5%	Q3 EMITTER RES
R15	165178	1	RESISTOR, 3.6K, 1/2W, 5%	Q3 LOAD RES
R16	137442	1	RESISTOR, 1.5K, 1/2W, 5%	C4 BLEEDER RES
R17	329273	1	RESISTOR, 470 OHM, 3/4W, 5%	COIL CURRENT LIMITER
R18	321258	1	RESISTOR, 20K, 1/2W, 5%	CR8 BIAS RES
C1	321158	1	CAPACITOR, 0.1 MFD	RF BYPASS CAPACITOR
C2	321157	1	CAPACITOR, 500 PFD	RF BYPASS CAPACITOR
C3	171829	1	CAPACITOR, 0.15 MFD	Q3 FEEDBACK CAPACITOR
C4	321264	1	CAPACITOR, 50V, 1.7 MFD	TRANSIENT SUPPLY
C5	178860	1	CAPACITOR, 100V, 0.022 MFD	RF BYPASS CAPACITOR
C6	171587	1	CAPACITOR, 200V, 0.25 MFD	Q4 FEEDBACK CAPACITOR
C7	171583	1	CAPACITOR, 0.003 MFD	RF BYPASS CAPACITOR
L1	321159	1	CHOKER, 39.0 OHM	RF CHOKER
CR1	321161	1	DIODE, 1N748A, 3.9V ±5%	REG VOLTAGE REF
CR3	197464	2	DIODE, (NOTE 7)	Q1 BASE PROT
CR4	178844	1	VARISTOR, 100-A	TEMP COMP.
CR5	178844	1	VARISTOR, 100-A	TEMP COMP.
CR6	178844	1	VARISTOR, 100-A	TEMP COMP.
CR7	181667	1	DIODE, 1N750A, 4.7V ±5%	TEMP COMP REF
CR8	312341	1	DIODE, (NOTE 7)	Q4 EMITTER DIODE
CR9		1	SAME AS CR3	TRANSIENT SUPPLY
Q1	321166	1	TRANSISTOR, 2N1893	DC AMP
Q2	324144	1	TRANSISTOR, 2N4121	DC AMP
Q3	321165	1	TRANSISTOR, 2N3638A	DC AMP
Q4	321261	1	TRANSISTOR, 2N4036	DC AMP
	324147	1	PAD, TRANSISTOR	
	144495	3	PAD, TRANSISTOR	
	321299	1	CIRCUIT BOARD, ETCHED	
T1-T4	137471	4	LUG, TERMINAL	
S1	39603RM	1	STRAP 5/8 IN. LONG	



NO.	NOTES
	ALL RESISTORS 1/2 WATT, ALL RESISTANCE VALUES IN OHMS AND ALL CAPACITANCE VALUES IN MFD UNLESS OTHERWISE SPECIFIED.
	Q5 (181875) AND CR2 (321149) ARE MOUNTED TO 321148 HEAT SINK. SEE CMD ASSEMBLY 333089
	R2 IS ADJUSTED FOR 12 TO 25 MA IN CR2 WITH INPUT MARKING (+S) AND OUTPUT CONNECTED TO A 330 OHM RESISTOR (5W)
	R7 IS ADJUSTED FOR SYMMETRICAL SWITCHING ABOUT ZERO.
	PINS A, B 48 MA TO COILS PINS R, S -7V DC PINS C, D -47 TO 53V DC POWER PINS N, P MS 1888 SIGNAL INPUT PINS K, L, M COMMON (ALL INPUTS AND OUTPUTS REFERRED TO COMMON)
	S NUMBER 615983
	PARTS CHANGED FOR STANDARDIZATION WERE FORMERLY AS FOLLOWS: CR3, CR9-321154 (IN457A), CR8-177611 (IN682).

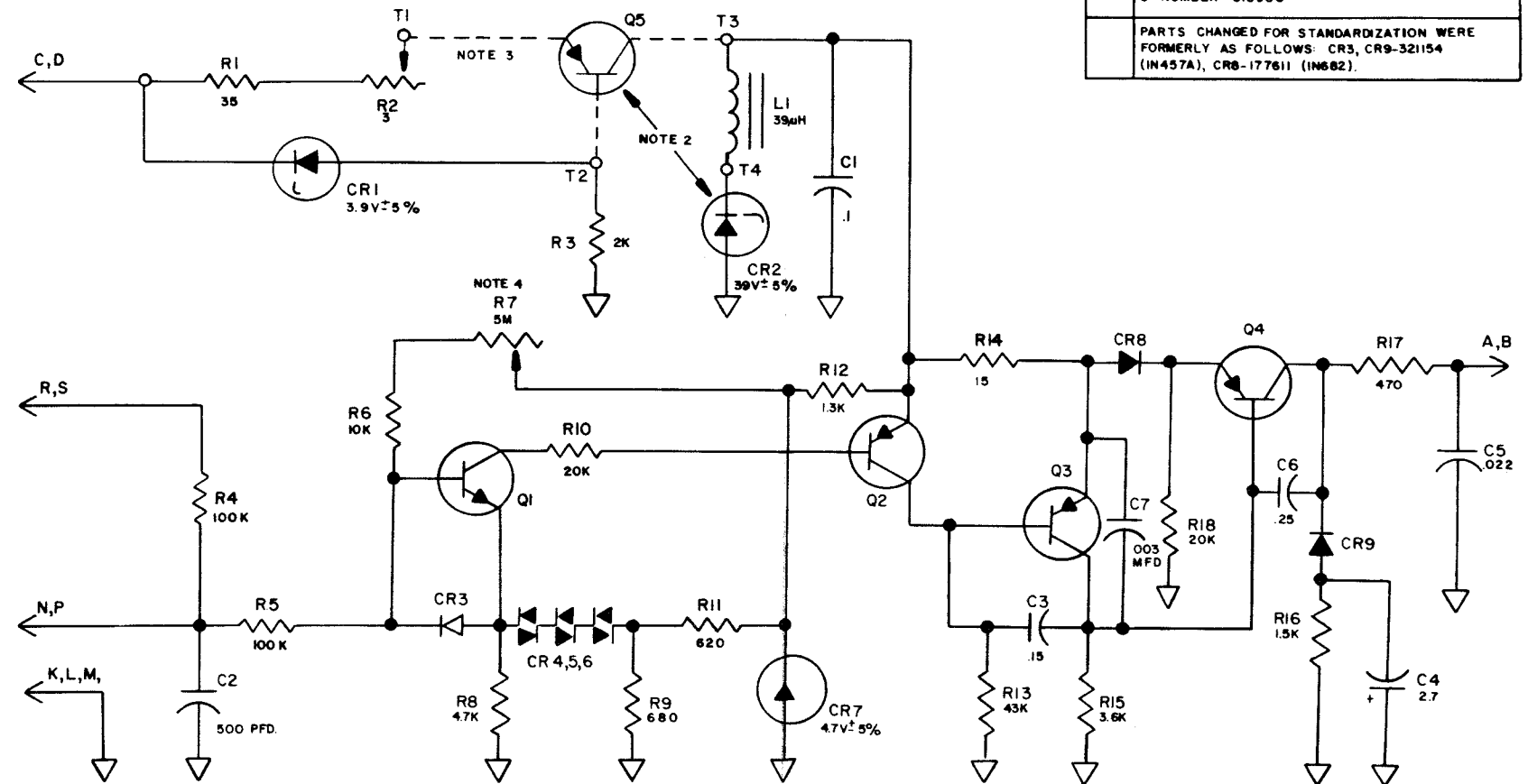



Figure 5-22. Schematic Diagram; Model 28 CPP KSR ESA CMD Circuit Board Assembly

NO.	NOTES
1.	ALL VOLTAGES DC UNLESS OTHERWISE SPECIFIED.
2.	TERMINAL DESIGNATION ENCLOSED IN PARENTHESIS ARE FOR REFERENCE AND ARE NOT MARKED ON COMPONENT.
3.	ALL SURFACE WIRE 24 AWG GREEN, 31784 RM, UNLESS OTHERWISE SPECIFIED.
4.	ALL STRAPPING WIRE 24 AWG BARE, 39603 RM, USE SLEEVING WHERE REQUIRED.
5.	* INDICATES TO TAPE END TERMINATING POINT.
6.	 INDICATES SINGLE SHIELDING
7.	 INDICATES DOUBLE SHIELDING
8.	THE PA CONNECTOR TAKES A 321290 CARD, THE SA TAKES A 323810 CARD.
9.	① INDICATES 18 AWG STRANDED WIRE.
10.	② INDICATES 24 AWG STRANDED WIRE.
11.	③ INDICATES 24 AWG 2 LEAD SINGLE SHIELDED CABLE.
12.	FUSE NUMBER: 162360 8/10AMP SLOW BLOWING
13.	SCHEMATIC DIAGRAM-8178 WD
14.	REFERENCE SPEC. FOR TELETYPE CORPORATION EMPLOYEES ONLY 61352 S
15.	COLOR CODE: BK-BLACK BL-BLUE W-WHITE R-RED Y-YELLOW BR-BROWN P-PURPLE O-ORANGE S-SLATE G-GREEN
16.	321226 ASSEMBLY USES TERMINAL BOARDS TA, TB, TC, TD AS SHOWN. 321231 ASSEMBLY USES 158250 TERMINAL BOARD AS TA, TB ONLY.
17.	PLACE A POLARIZING KEY IN SA CONNECTOR BETWEEN E AND F, IN PA CONNECTOR BETWEEN M AND N.

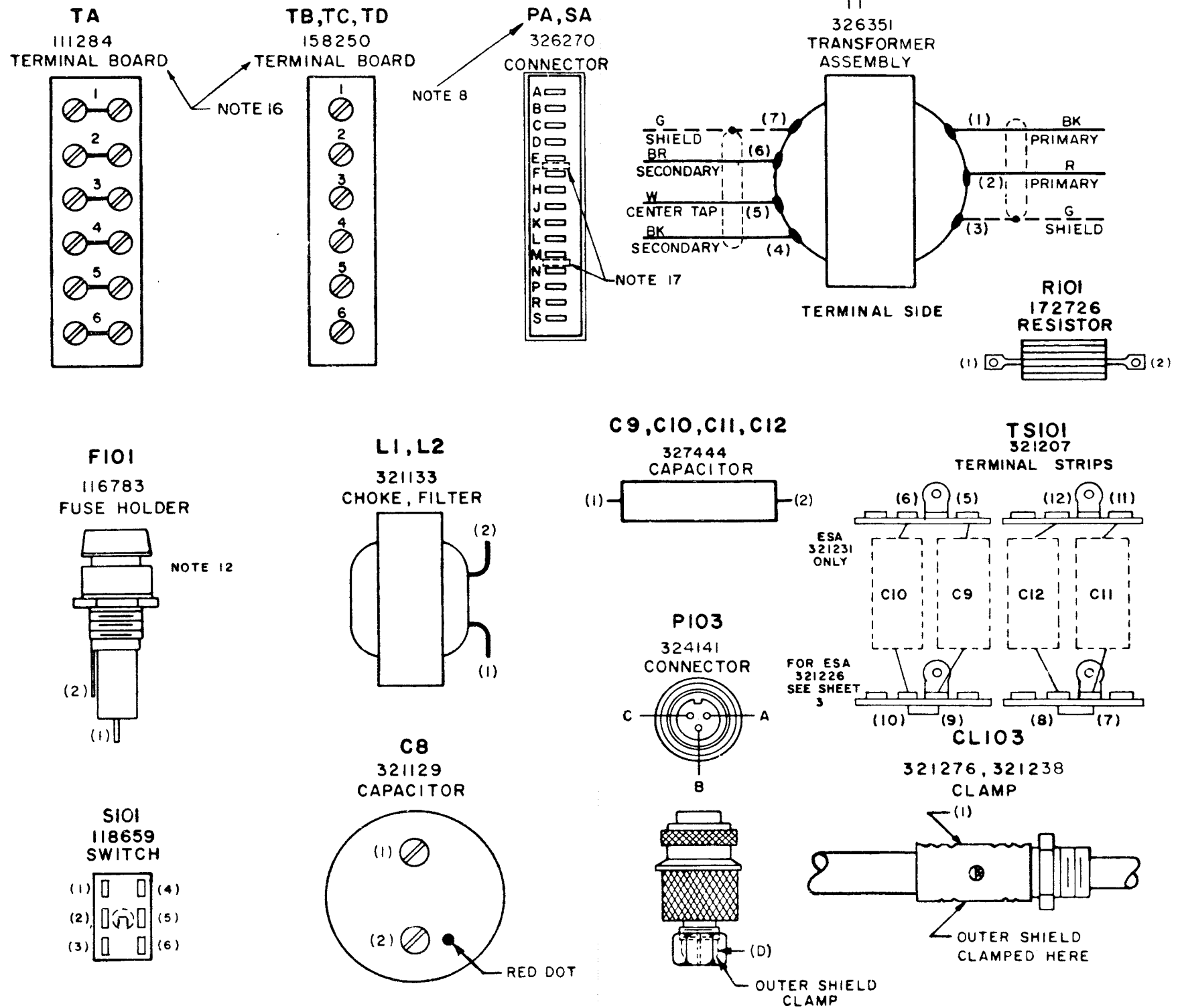

Figure 5-23. Wiring Diagram; Model 28 CPP KSR ESA 323121 (SMD and LLK) (Sheet 1 of 3)

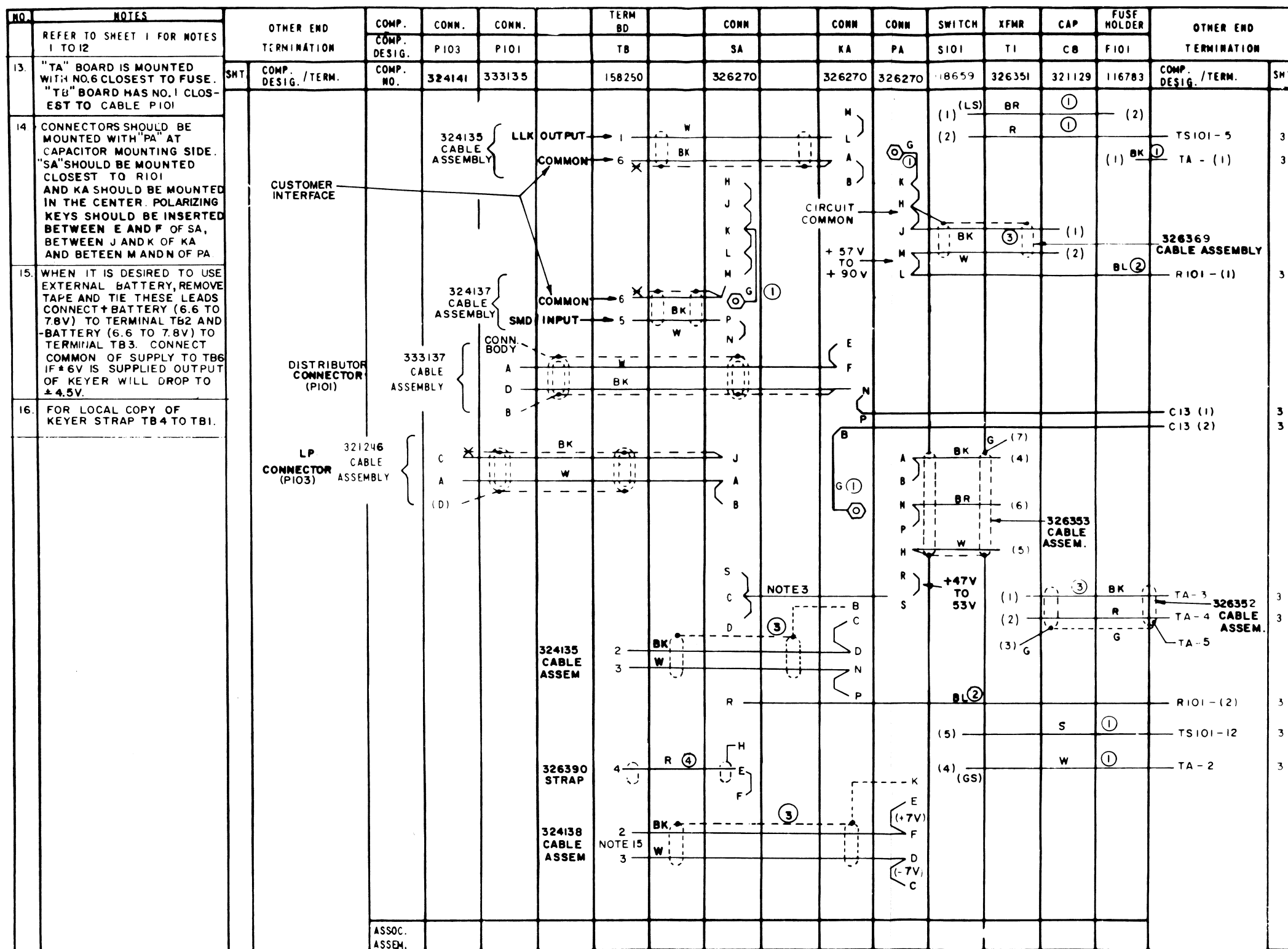

Figure 5-23. Wiring Diagram; Model 28 CPP KSR ESA 323121 (SMD and LLK) (Sheet 2 of 3)

NOTES	
1.	INDICATES OUTER SHIELD AND INDICATES INNER SHIELD
2.	CAPACITANCE VALUES IN MICROFARADS, UNLESS OTHERWISE SPECIFIED.
3.	INDICATES FEMALE AND INDICATES MALE TERMINALS ON CONNECTORS
4.	SL-BL INDICATES SLOW-BLOWING.
5.	S-NUMBER 61,599
6.	ALL VOLTAGES DC, UNLESS OTHERWISE SPECIFIED.
7.	TERMINAL DESIGNATIONS ENCLOSED IN PARENTHESES ARE FOR REFERENCE AND ARE NOT MARKED ON COMPONENT.
8.	WIRING DIAGRAM - 8728 WD
9.	RESISTANCE VALUES IN OHMS UNLESS OTHERWISE SPECIFIED.
10.	FOR LOCAL COPY FROM KEYS, STRAP TB4 TO TB1.
11.	WHEN IT IS DESIRED TO PROVIDE AN EXTERNAL +7V AND -7V, REMOVE THE +7V AND -7V LEADS FROM TB2 AND TB3. CONNECT COMMON OF EXTERNAL SUPPLY TO TB6
12.	REFER TO RELATED SET SCHEMATIC 8728 WD FOR EXTERNAL CIRCUITS.
13.	INDICATES SINGLE SHIELDING INDICATES DOUBLE SHIELDING
14.	INDICATES CIRCUIT COMMON

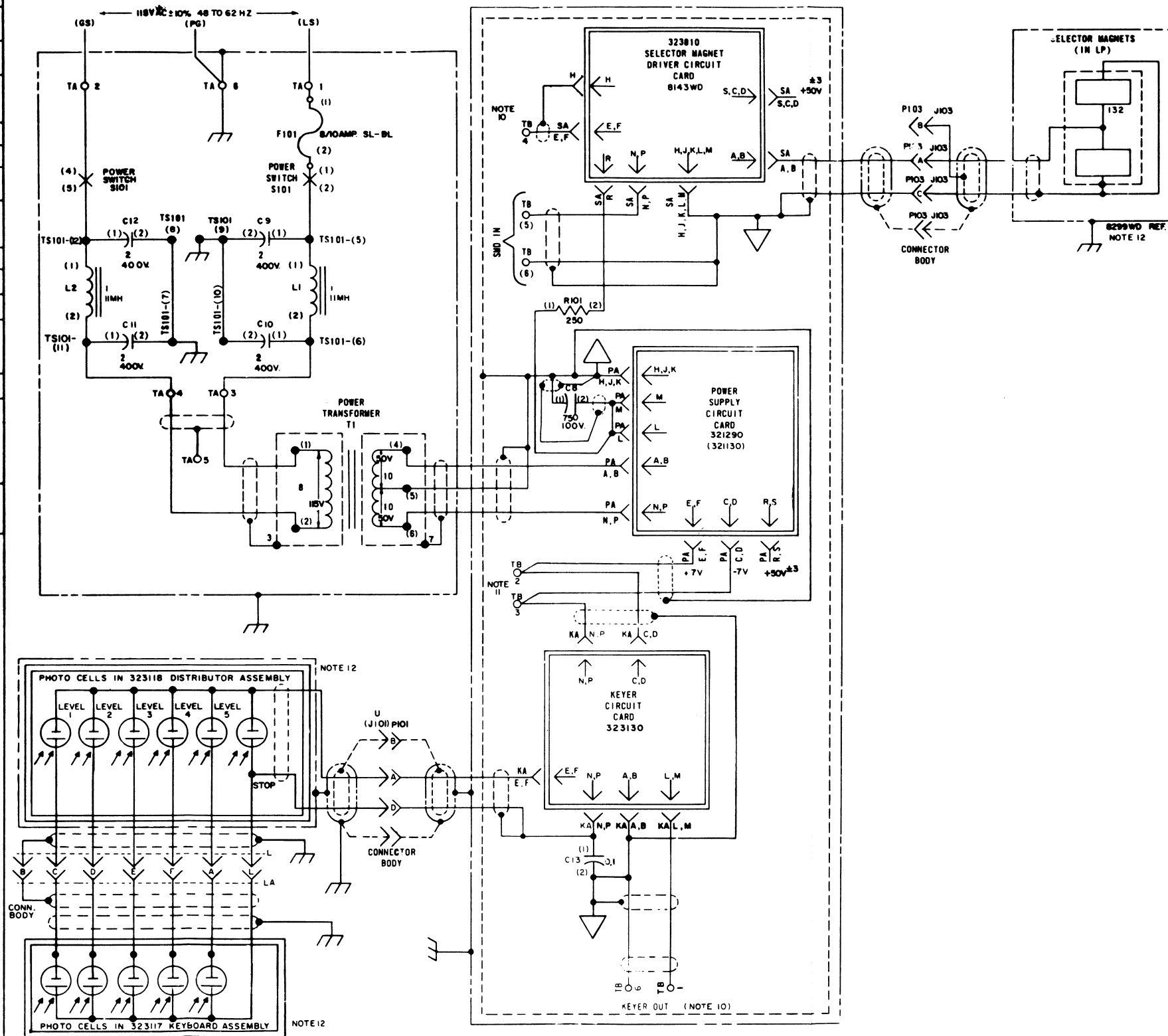
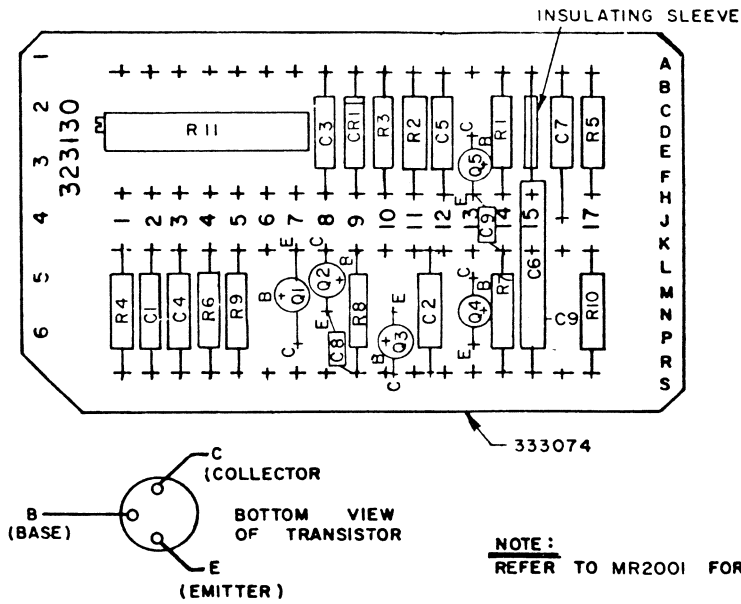

Figure 5-24. Schematic Diagram; Model 28 CPP KSR
ESA 323121 (SMD and LLK)

NOTES:

1. DUE TO VARIATIONS OF TRANSISTOR CHARACTERISTICS, "L1" WAS ADDED TO PROVIDE AN ACCEPTABLE RESPONSE TIME. "L1" SHOULD BE ADDED IF Q2 IS REPLACED.



NOTE:
REFER TO MR2001 FOR MARKING INFORMATION.

REF. DESIGN.	TELETYPE PART NO.	TOTAL QTY.	NAME AND DESCRIPTION	LOCATING	FUNCTION
C1,2	320048	2	CAPACITOR .5 MFD ± 10%		
C8,9	315976	2	CAPACITOR 470PF ± 20% 50 V.		
C3	320049	1	CAPACITOR .15 MFD ± 10%		
C4	181618	1	CAPACITOR .01 MFD ± 20%		
C6,7	321262	2	CAPACITOR 1.0 MFD ± 20%		
R1	323147	1	RESISTOR 36K OHMS 1/4 WATT ± 5%		
R2,3	118146	2	RESISTOR 4.7K OHMS 1/2 WATT ± 5%		
R4,5	118149	2	RESISTOR 12 K OHMS 1/2 WATT ± 5%		
R6,7,8	118147	3	RESISTOR 6.8K OHMS 1/2 WATT ± 5%		
R9	118179	1	RESISTOR 330K OHMS 1/2 WATT ± 5%		
R10	137438	1	RESISTOR 100 OHMS 1/2 WATT ± 5%		
R11	321160	1	RESISTOR 5M OHMS(POT)1/2 WATT ± 5%		
Q1,3,5	323934	3	TRANSISTOR, 2N3565		
Q2,4	324144	2	TRANSISTOR 2N4121		
CR1	177108	1	DIODE, D-2		
C5	305821	1	CAPACITOR .1 MFD. ± 20% 25 V.		
L1	343619	1	FERRITE BEAD		
	60340RM	1"	INSULATING SLEEVE		
	333074	1	BOARD, ETCHED CIRCUIT		
	324147	5	TRANSISTOR PAD		

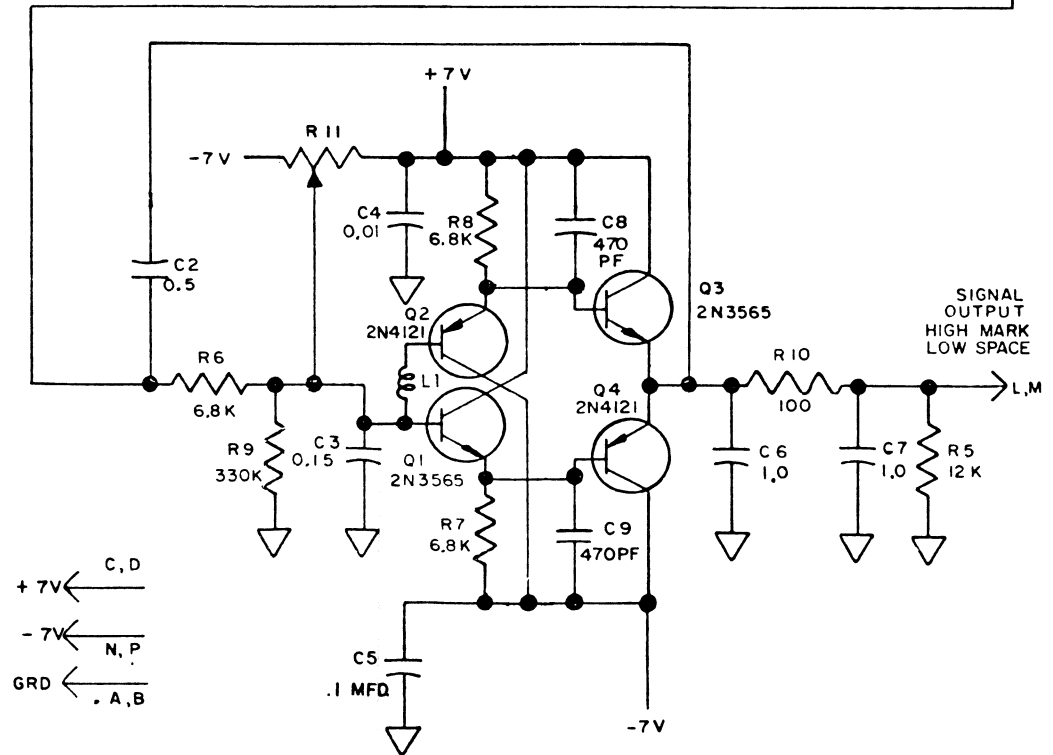
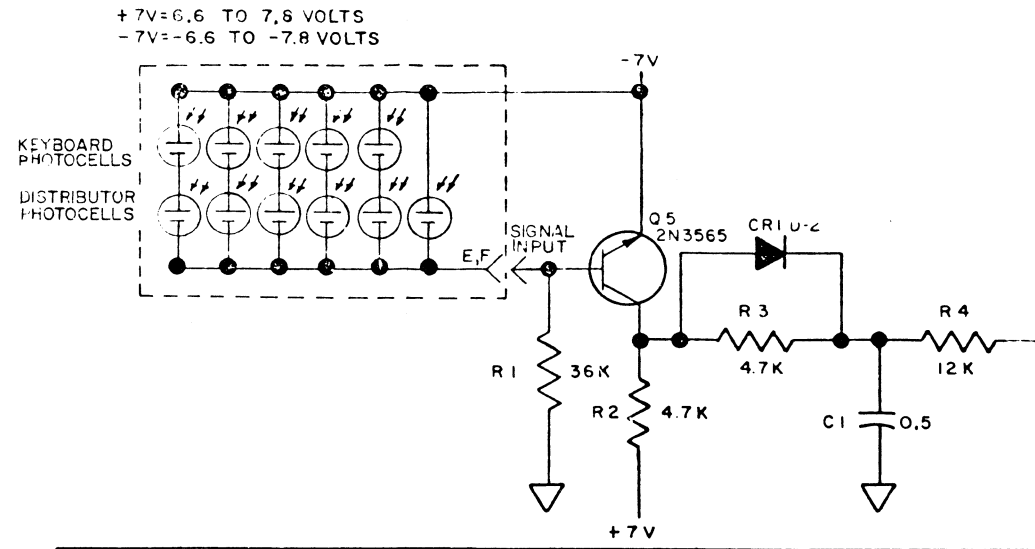

NOTE:
CARD CONNECTIONS ARE REPRESENTED BY LETTERS
TEST POINTS ARE REPRESENTED BY NUMBERS.

Figure 5-25. Schematic Diagram; Model 28 CPP KSR
ESA LLK Circuit Board Assembly

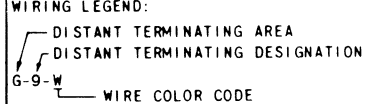
NO.	NOTES
1.	WIRING LEGEND: 
2.	COLOR CODE: BK - BLACK G - GREEN BL - BLUE R - RED BR - BROWN O - ORANGE Y - YELLOW S - SLATE P - PURPLE W - WHITE
3.	CONNECTORS VIEWED FROM SOLDER END.
4.	SPARE TERMINAL BLOCK PROVIDED FOR CUSTOMER CONVENIENCE.
5.	ALL WIRES TO BE 24 GA. EXCEPT AS NOTED: *18 GA WIRE
6.	327326 GROUND STRAP CONNECTED BETWEEN INNER AND OUTER PAN NEAR MOTOR.
7.	NUMERALS IN PARENTHESIS ARE NOT MARKED ON THE COMPONENTS BUT ARE SHOWN FOR PROPER ORIENTATION.
8.	ASSOCIATED WIRING DIAGRAMS: 8137WD - 321231 ESA 8176WD - RFH8000B SCHEMATIC 8177WD - RFH8001B 8178WD - LPC402 COVER 8178WD - 321231 ESA SCHEMATIC 8242WD - LP139
9.	GROUND SCREW LOCATED ON TERMINAL BLOCK MOUNTING BRACKET FOR CUSTOMER'S TERMINAL GROUND CONNECTION.
10.	ASSOCIATED CABLES: 324497 CABLE ASSEMBLY 324523 CABLE ASSEMBLY
11.	----- INDICATES CUSTOMER FURNISHED WIRING
12.	REFERENCE SPEC. FOR TELETYPE CORPORATION EMPLOYEES ONLY 613515

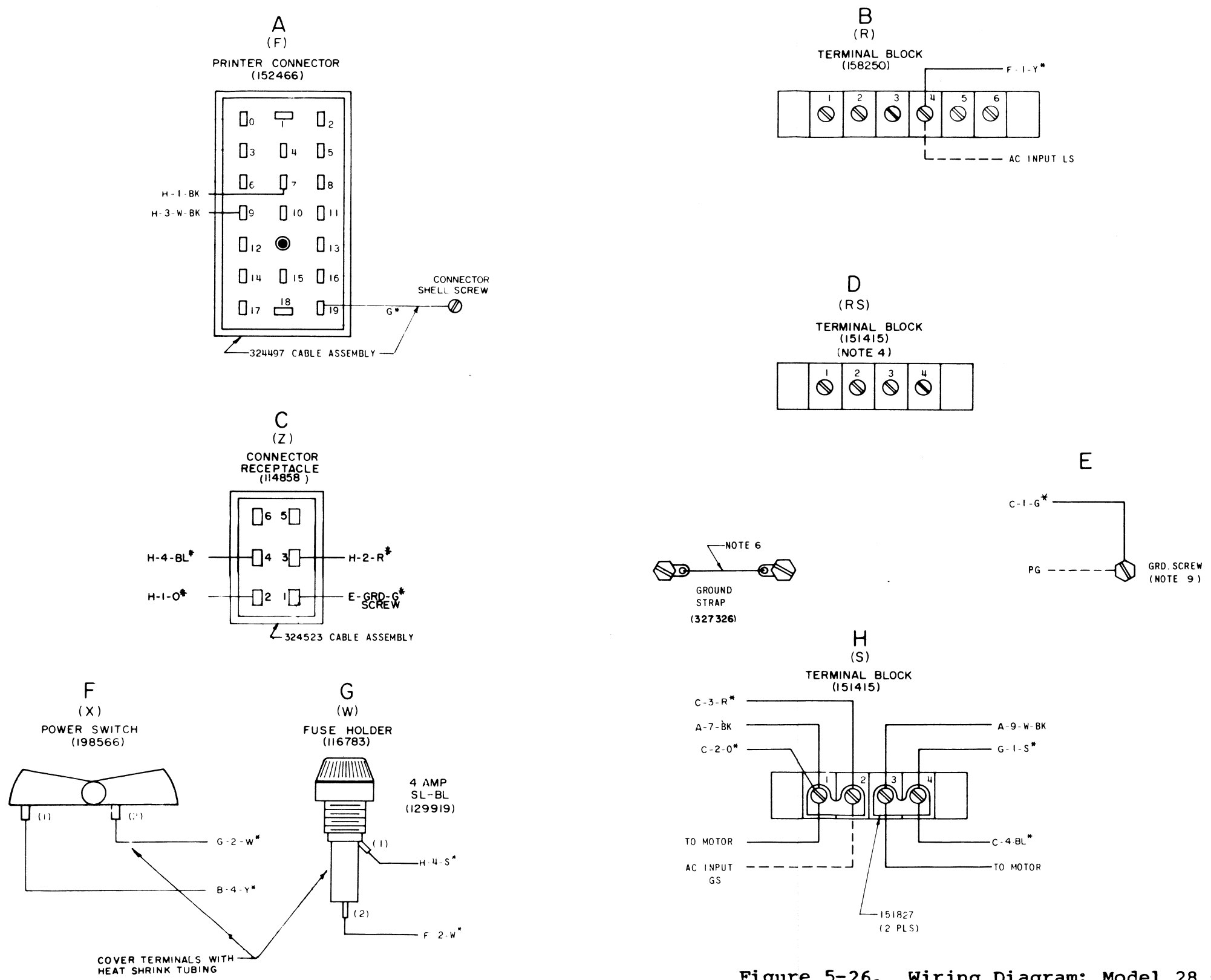
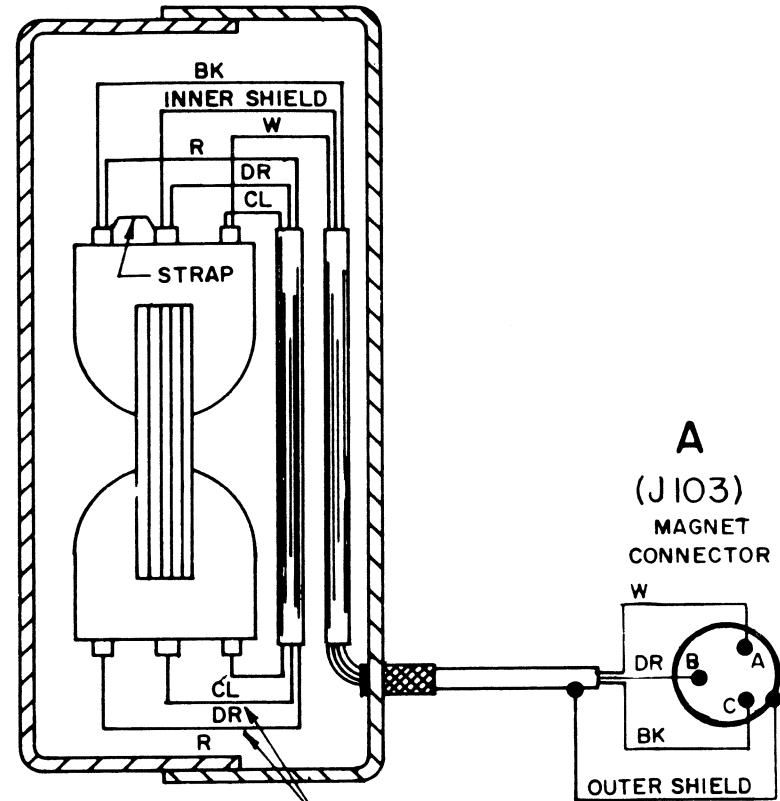

Figure 5-26. Wiring Diagram; Model 28 CPP RO Base LLB 5

NO.	NOTES										
1.	<p>AREA DESIGNATION TERMINATING DESIGNATION COLOR CODE</p>										
2.	<p>COLOR CODE:</p> <table border="0"> <tr> <td>BK - BLACK</td> <td>BL - BLUE</td> </tr> <tr> <td>W - WHITE</td> <td>R - RED</td> </tr> <tr> <td>Y - YELLOW</td> <td>BR - BROWN</td> </tr> <tr> <td>P - PURPLE</td> <td>O - ORANGE</td> </tr> <tr> <td>S - SLATE</td> <td>G - GREEN</td> </tr> </table>	BK - BLACK	BL - BLUE	W - WHITE	R - RED	Y - YELLOW	BR - BROWN	P - PURPLE	O - ORANGE	S - SLATE	G - GREEN
BK - BLACK	BL - BLUE										
W - WHITE	R - RED										
Y - YELLOW	BR - BROWN										
P - PURPLE	O - ORANGE										
S - SLATE	G - GREEN										
3.	CONNECTOR VIEWED FROM SOLDERED TERMINAL ENDS.										
4.	*DENOTES 18 GA. - ALL OTHER WIRES 24 GA..										
5.	<p>NORMALLY OPEN CONTACT NORMALLY CLOSED CONTACT</p>										
6.	<p>ASSOCIATED WIRING DIAGRAMS</p> <p>8137WD-321231 ESA WIRING 8176WD-VSL 536 AND 537 SCHEMATIC 8177WD-LPC 402 WIRING 8178WD-321231 ESA SCHEMATIC 8179WD-VSL 536 AND 537 WIRING 8331WD-326471 ESA SCHEMATIC</p>										
7.	<p>ASSOCIATED CABLES:</p> <p>155066 - CABLE ASSEMBLY 195353 - CABLE ASSEMBLY</p>										
8.	<p>LEGEND:</p> <p>CL - CLEAR INSULATION. DR - DRAIN LEAD.</p>										
9.	<p>REFERENCE SPEC. FOR TELETYPE CORPORATION EMPLOYEES ONLY</p> <p>61351 S</p>										
10.	TAPE ENDS AND TIE BACK 152468 CABLE IF NOT USED.										

MAGNET AND BASE ASSEMBLY (319230)



(B)
C
SIGNAL BELL (159611)

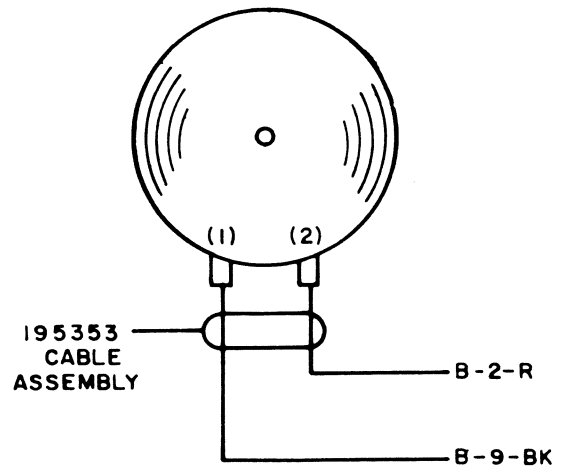

B
(F)
PRINTER CONNECTOR (152467)

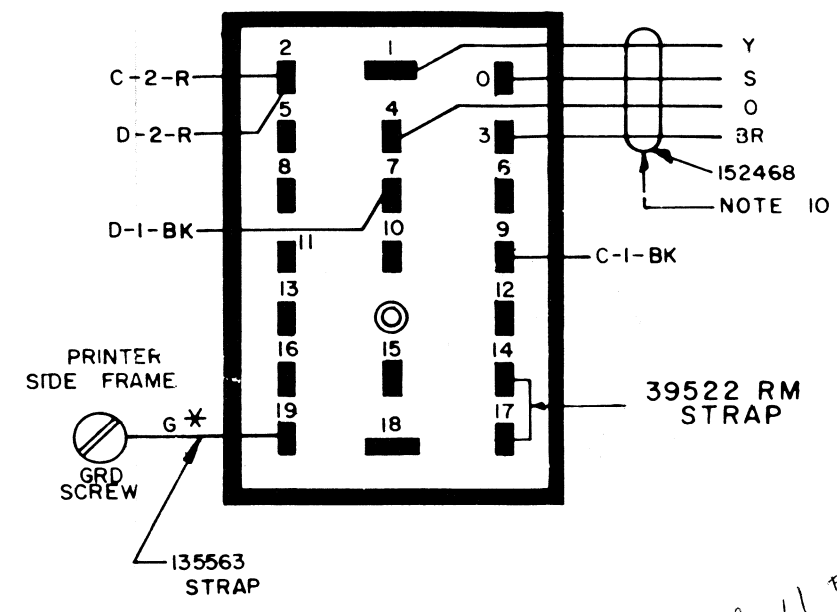

*Bell #2 to (Red) Printer Recip #2
Bell #1 to Printer Recip #1 (BL)*

D
(C)
STUNT BOX CONTACT ARRANGEMENT AJF, AJG, ACX, AKH (172502)

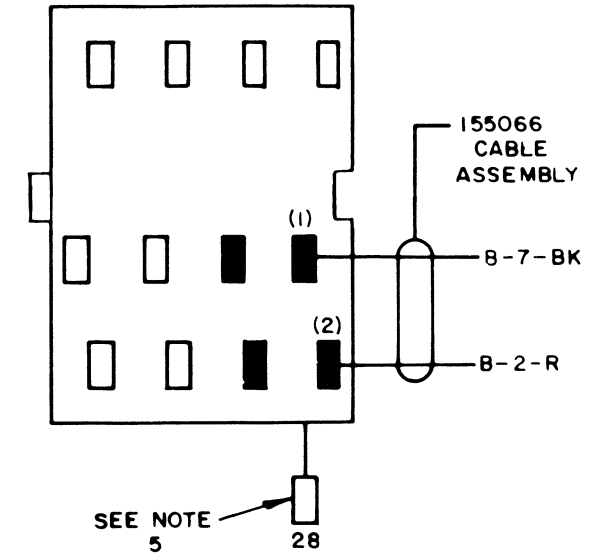

Figure 5-27. Wiring Diagram; Model 28 CPP RO Typing Unit LP 139 5-93/5-94 blank

ck/aly

NO.	NOTES
1	CONNECTOR VIEWED FROM SOLDER TERMINAL END.
2	SELECTOR MAGNETS ARE WIRED FOR .060 AMPERE OPERATION OR USE WITH 323810 SELECTOR MAGNET DRIVER.
3	COLOR CODE R- RED W- WHITE BK- BLACK
4	REFERENCE SPEC. FOR TELETYPE CORPORATION EMPLOYEES ONLY 61213S
5	LEGEND: DR-DRAIN CL-CLEAR INSULATION
6	REFER TO APPROPRIATE SET SCHEMATIC WIRING DIAGRAM FOR J CONNECTOR NUMBER.

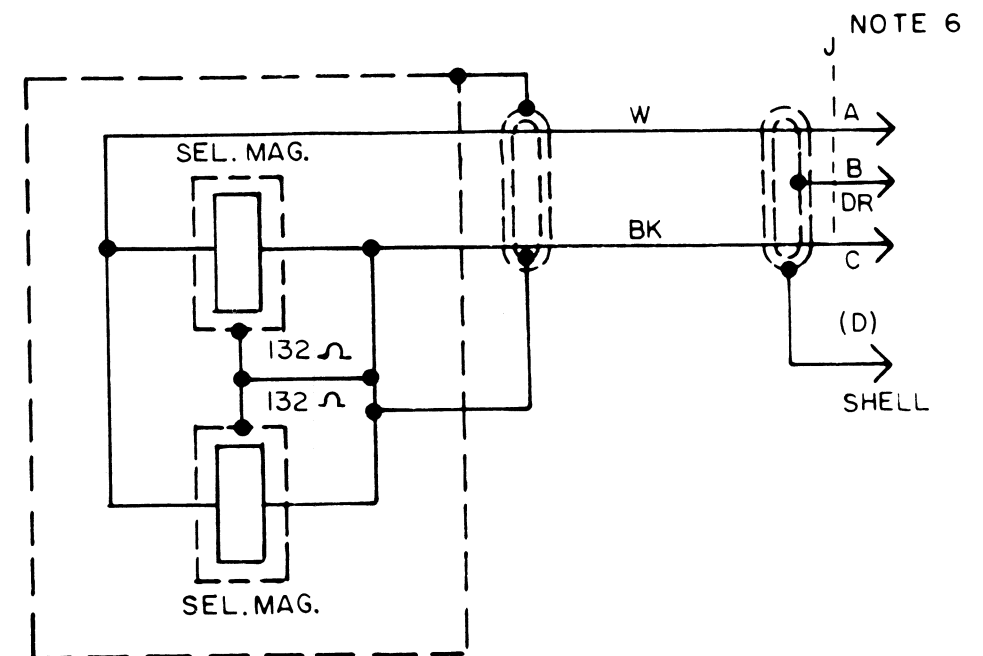
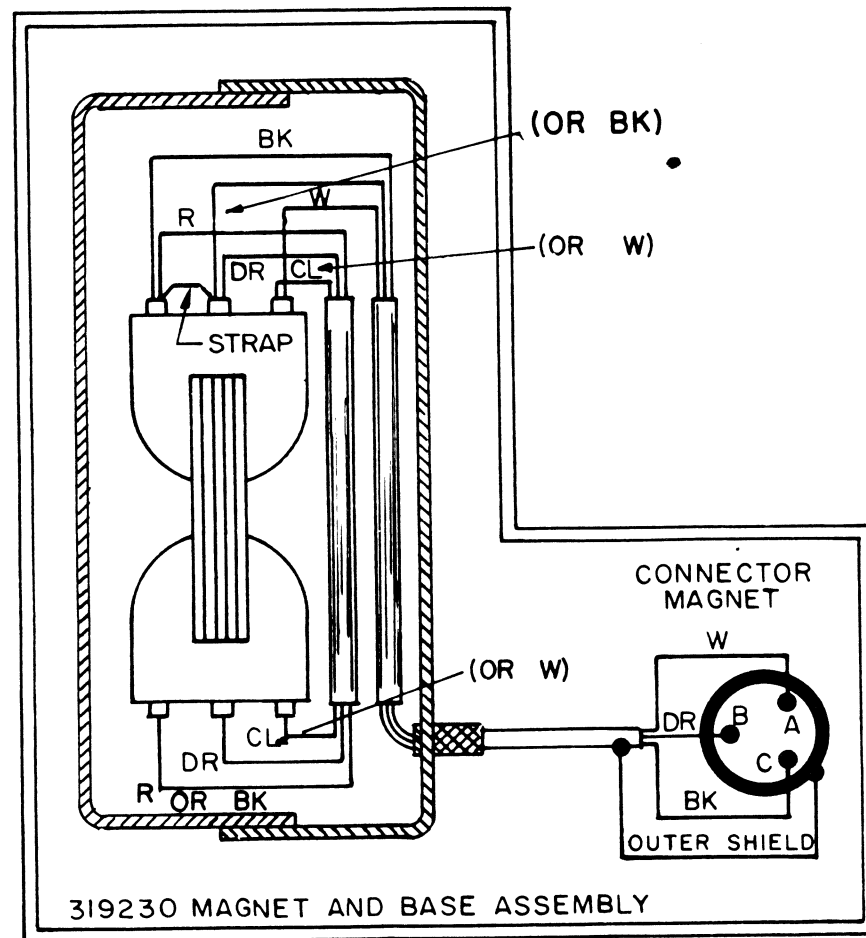

Figure 5-28. Wiring Diagram; Model 28 CPP RO Typing Unit Selector Assembly 319204

NO.	NOTES
1.	
2.	COLOR CODE: BK - BLACK BL - BLUE W - WHITE R - RED Y - YELLOW BR - BROWN P - PURPLE O - ORANGE S - SLATE G - GREEN
3.	CONNECTOR VIEWED FROM SOLDERED TERMINAL ENDS.
4.	* DENOTES 18 GA., ALL OTHER WIRES 24 GA.
5.	
6.	ASSOCIATED WIRING DIAGRAMS: 8724WD 323120 ESA ACTUAL 8725WD 323120 ESA SCHEMATIC 8726WD 323121 ESA ACTUAL 8727WD 323121 ESA SCHEMATIC 8728WD 323116 MOD. KIT ACTUAL 8729WD 323116 MOD. KIT SCHEMATIC 8764WD 1PC403 ACTUAL
7.	ASSOCIATED CABLES: 155066 - CABLE ASSEMBLY 195353 - CABLE ASSEMBLY 333118 - CABLE ASSEMBLY
8.	LEGEND: CL - CLEAR INSULATION DR - DRAIN LEAD
9.	S NUMBERS 61,351S 61,600S
10.	X INDICATES SPLICE
11.	TERMINAL DESIGNATIONS ENCLOSED IN PARENTHESIS ARE FOR REFERENCE ONLY AND ARE NOT MARKED ON COMPONENTS
12.	USE SUITABLE TUBING OVER TERMINALS.
13.	CABLE 152468 (PART OF STUNT BOX) MAY BE CLIPPED AND DISCARDED.

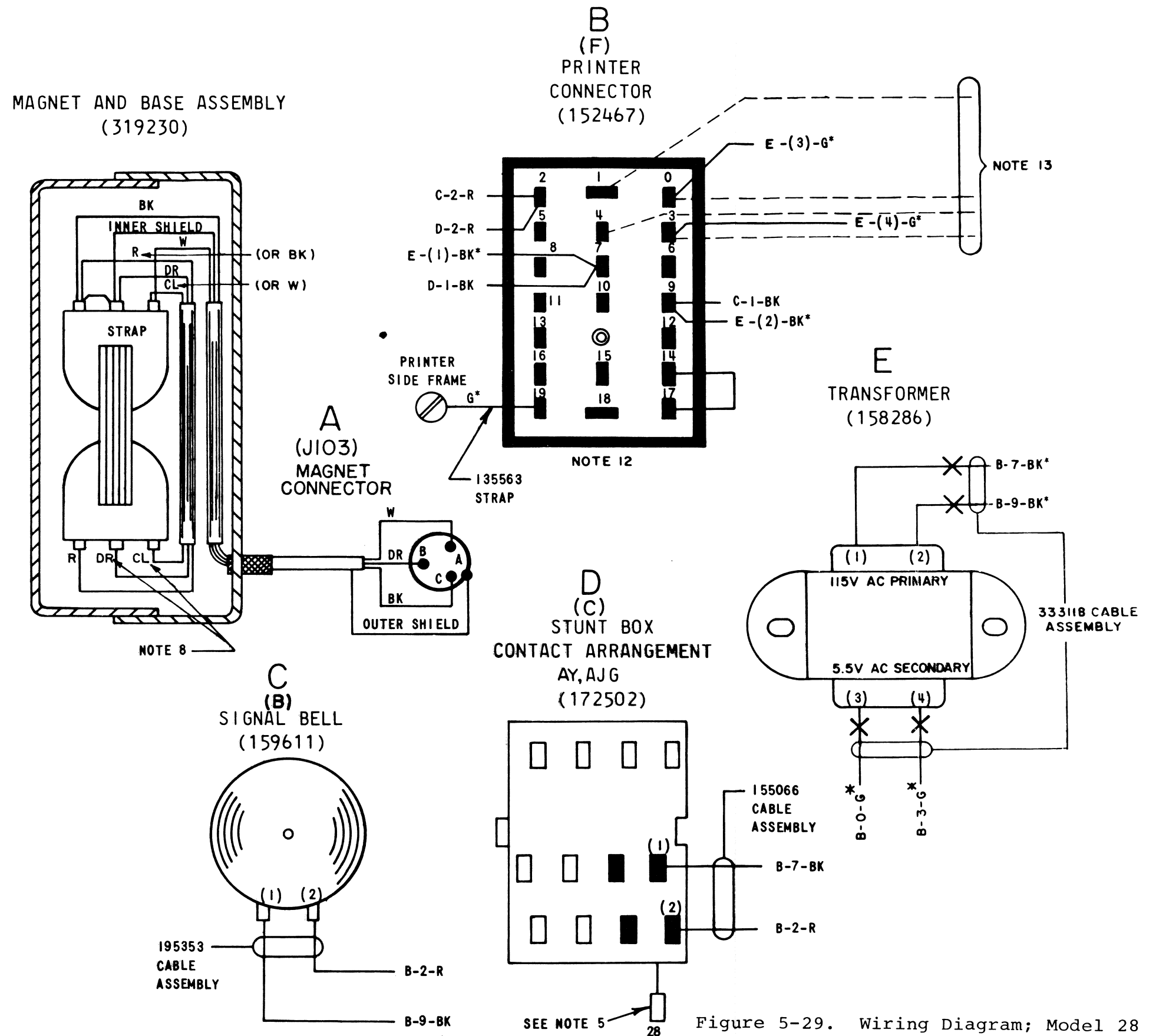

Figure 5-29. Wiring Diagram; Model 28 CPP KSR Typing Unit LP 156