

Manual 368
Issue 1, March 1977

The **43 Teleprinter**

**INSTALLATION
& SERVICING**



FOR BASIC KSR TERMINALS

THE 43 TELEPRINTER
BASIC KSR
INSTALLATION AND SERVICING MANUAL

	<u>PAGE</u>
PART 1 -- INTRODUCTION	
PART 2 -- INSTALLATION	
A. VARIABLE FEATURES	2-1
B. INTERFACES	2-2
C. ASSEMBLY	2-6
1. UNPACKING	2-6
2. TELEPHONE AND LINE CONNECTION	2-6
3. ACCESSORIES	2-6
4. STATION TESTING	2-6
PART 3 -- SERVICING	
A. TROUBLE ISOLATION AND CORRECTION	3-1
B. PERIODIC CHECKS, LUBRICATION AND CLEANING	3-4
1. GENERAL	3-4
2. VISUAL CHECKS	3-4
3. CLEANING AND APPEARANCE	3-4
4. LUBRICATION PROCEDURES	3-4
5. LUBRICATION POINTS	3-6
C. COMPONENT ACCESS	3-7
1. OPERATOR CONSOLE, CABLES, DIRECTORY CARD AND VARIABLE FEATURE SWITCH	3-7
2. POWER SUPPLY LAMP, CABLES AND FUSES.	3-7
D. ADJUSTMENTS	3-8
1. RIGHT PAPER SPROCKET	3-8
2. PLATEN ENDPLAY AND PRINTED LINE POSITION	3-8

PART 2 -- INSTALLATION
A. VARIABLE FEATURES

The chart below provides information on how to set the feature shown under feature numbers 431 through 435.

Feature No.	Feature Suffix and Conditions	Feature Definition	Switch Numbers								Location of Switch on Circuit Card (See Page 3-7)
			SPD4								
XXX			1	2	3	4	5	6	7	8	
a.			—	—	—	—	○	●	—	—	*
b.			—	—	—	—	○	●	—	—	
c.			—	—	—	—	●	○	—	—	
431. Type Font Arrangement			SPD4								
			1	2	3	4	5	6	7	8	
a.	Narrow numeric 0 and wide alpha O. Standard ^ and underline _		—	—	—	—	—	—	●	●	*
b.	Slash numeric / and wide alpha O. ^ prints as ↑ and _ prints as ←.		—	—	—	—	—	—	●	○	
c.	Slash alpha / and wide numeric O. ^ prints as ↑ and _ prints as ←.		—	—	—	—	—	—	○	○	
432. Line Length			SPD4								
			1	2	3	4	5	6	7	8	
a.	132 Characters		—	—	—	—	●	●	—	—	*
b.	72 Characters		—	—	—	—	○	●	—	—	
c.	80 Characters		—	—	—	—	●	○	—	—	
433. EOT Disconnect			SPD4								
			1	2	3	4	5	6	7	8	
a.	Disconnect on EOT		—	—	—	○	—	—	—	—	*
b.	Does not disconnect on EOT		—	—	—	●	—	—	—	—	
434. Character Parity Bit Sent			SPD4								
			1	2	3	4	5	6	7	8	
a.	Even Parity		—	—	○	—	—	—	—	—	*
b.	8th Bit Mark		—	—	●	—	—	—	—	—	
435. End-of-Line on Receive			SPD4								
			1	2	3	4	5	6	7	8	
a.	Auto CR-LF performed		○	—	—	—	—	—	—	—	*
b.	Bell & Print Inhibit at last char. position		●	—	—	—	—	—	—	—	

- Indicates toggle or slide position to ON.
- Indicates toggle or slide position to OFF.
- Position of switch does not affect feature.
- * Factory furnished state of feature.

B. INTERFACES

The 4320AAB set equipped with 430750 Terminal Data Unit (TDU) provides two modular telephone jacks for connection to the telephone equipment using modular cords. These jacks are labeled line (bottom) and phone (top). The pin assignments are given below:

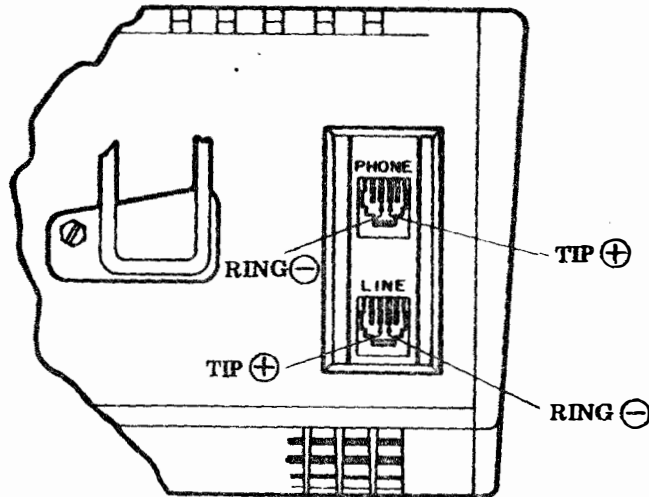

The 4320AAC set equipped with a 430751 Terminal Auxiliary Unit (TAU) provides a 25-pin male connector for connection to a stand-alone data set. The interface meets the requirements of EIA-RS-232C. The pin assignments are given below:

EIA DATA SET INTERFACE SIGNALS

<u>Connector Pin</u>	<u>Signal</u>	<u>EIA Circuit</u>
1	Protective Ground	AA
2	Transmit Data	BA
3	Receive Data	BB
4	Request to Send (Future)	RS
5	Clear to Send	CB
6	Data Set Ready	CC
7	Signal Gnd	AB
8	Received Line Signal Detector	CF
9		
10		
11	TWX Control	-
12	Data Speed Indicator	SCF
13		
14		
15		
16		
17		
18	TWX Indicator	-
19		
20	Data Terminal Ready	CD
21		
22		
23	Data Speed Select	CH
24		
25	Analog Loop Test	

The 4320AAA set is furnished without the interface signaling unit. Connection to the external communications device (provided by the customer) is made through a 20-pin connector, Berg 65346-003 or 3M 3421-300 or equivalent at the end of a short ribbon cable. No provision is made for adding additional cable length.

Electrical Characteristics of Interface Leads are:

Electrical signals compatible with low-power TTL logic are utilized for both control and data interchange as described below:

STATE	DRIVER	TERMINATOR
MARK (OFF) (1)	$+2.4 \leq V_{\text{MARK}} \leq +5.25$ Volts	$+2.0 \leq V_{\text{MARK}} \leq +5.25$ Volts
SPACE (ON) (0)	$0 \leq V_{\text{SPACE}} \leq +0.4$ Volts	$0 \leq V_{\text{SPACE}} \leq +0.7$ Volts

TTL PIN ASSIGNMENT CHART

<u>Pin No.</u>	<u>Code</u>	<u>Function</u>
1	DL	Digital Loop Test
2	DSI	Data Speed Indicator to Terminal
3	AL	Analog Loop Test
4	DSS	Data Speed Select from Terminal
5	TR	Terminal Ready
6	RS	Request to Send (Future)
7	+5	+5 Volts
8		Reserved for future
9	GND	Circuit Ground
10		Reserved for future
11	-12	-12 Volts
12		Reserved for future
13	+12	+12 Volts
14	DP	Duplex Indicator from Terminal (Future)
15	DR	Data Ready
16	TW2	TWX Indicator (Future)
17	RD	Receive Data
18	TW1	TWX Control (Future)
19	SD	Transmit Data
20		Reserved for future

C. ASSEMBLY

The basic 43 Teleprinter set is furnished fully assembled and tested with one of the signal interfaces described on Page 2-2, B. INTERFACES.

1. UNPACKING

- a. Unpack the large carton referring to instructions on the container.
- b. Remove tape securing the cover to the housing. (see below).
- c. Depress the cover locking tabs on the lower front of the cabinet and lift the cover. Remove the packing detail securing the print head (see below).
- d. Verify that the following items are included in the box:

- 1 - Set -- 43 Teleprinter (4320AAA, AAB, or AAC)
- 1 - Ribbon
- 1 - Manual, Installation and Servicing, 368
- 1 - Manual, Attendant, 367
- 1 - Paper Holder

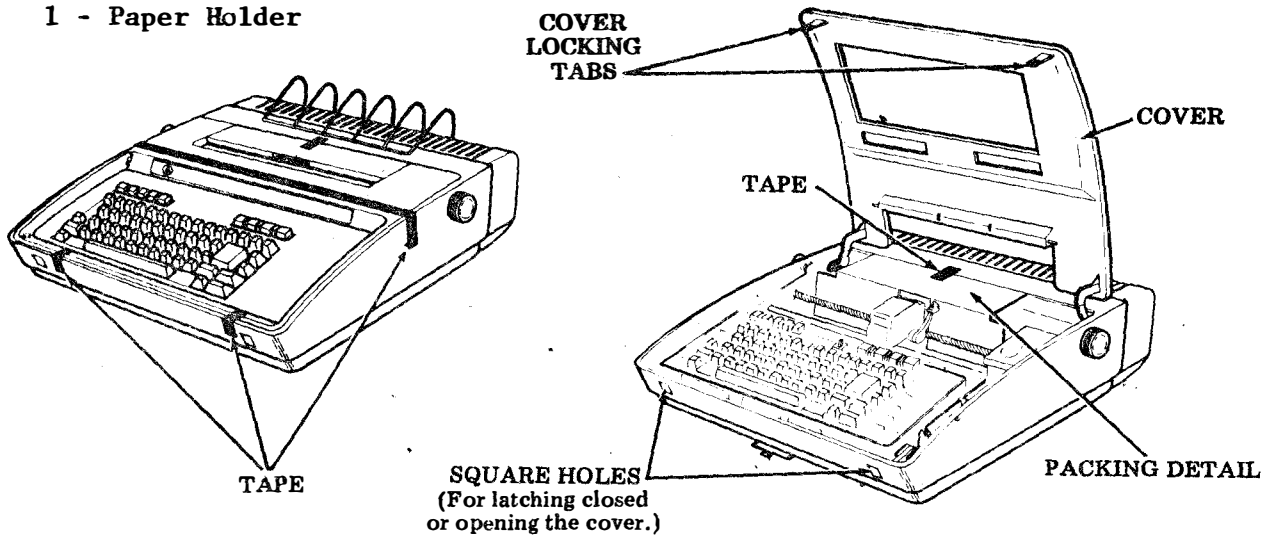

NOTE: Fan-fold 12 x 8-1/2 inch paper and modular telephone cords must be obtained locally.

2. TELEPHONE AND LINE CONNECTION

NOTICE: In the U.S.A., only telephone company installers should connect the 43 Teleprinter directly to the switched network.

4320AAB Set W/TDU

- a. Remove the modular cord plug from the modular jack associated with the keyless telephone to be used with the teleprinter. Connect the plug to the lower connector marked LINE on the rear of the TDU accessible through the opening in the left rear of the bustle cover (Page 2-5).
- b. Connect the locally obtained modular cord between the upper connector on the TDU marked PHONE and the telephone jack (Page 2-5).

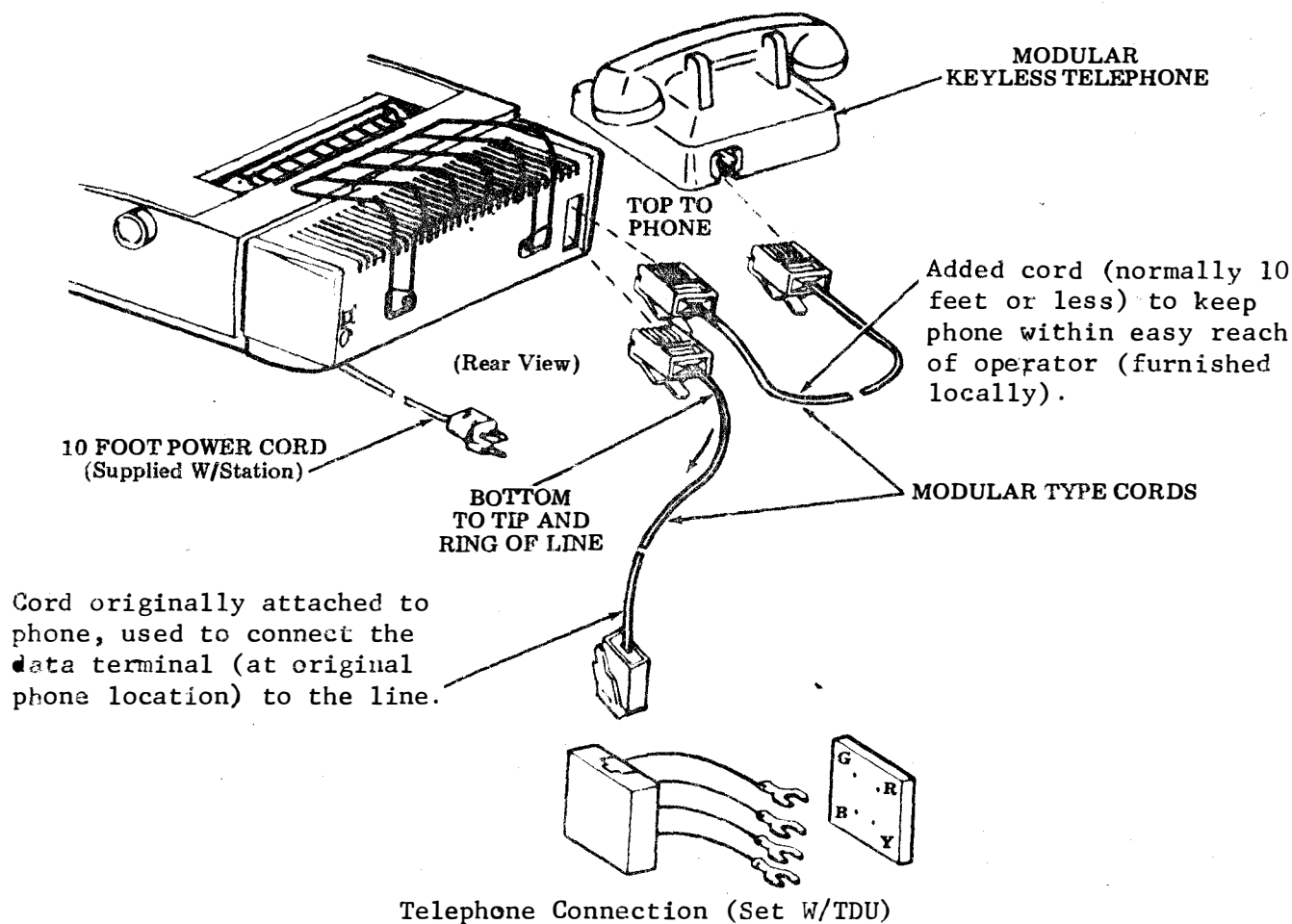

4320 AC Set With TAU

- a. The connecting cables between the terminal and the data set must be furnished by the installer and should employ shielded cable. The following cables are available from Teletype Corporation.

7 foot length	408065
12 foot length	408066
25 foot length	408067
50 foot length	408068

- b. The connection to the data set and telephone should be made following the instructions for the particular data set involved (Page 2-6).

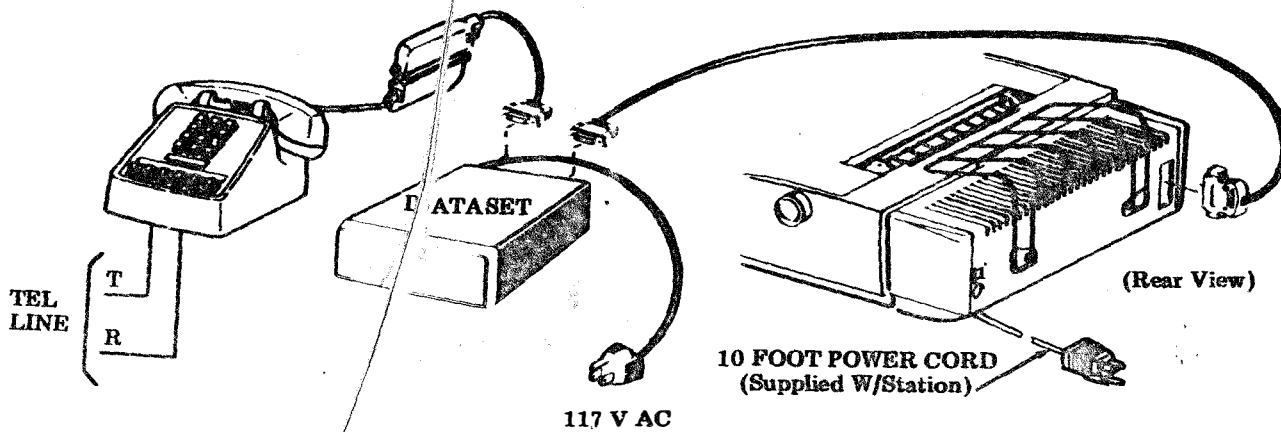

Telephone Connection (Set W/TAU)

4320AAA Set With Interface Signaling Unit

Connection to the 43 Teleprinter interface cable requires the removal of the paper holder (if present), paper deflector and bustle cover. Refer to Page 3-7, C. COMPONENT ACCESS for removal instructions.

This set is not equipped with a communications unit and telephone and line connections cannot be made until the KSR set is provided with an appropriate communications device. The connections to the telephone, data set or communications device should be done following the instructions for the particular device involved.

3. ACCESSORIES

- a. Install the ribbon and paper. Refer to Manual 367.
- b. Install the paper holder if desired. Refer to Page 3-7.
- c. Record any nonstandard options enabled in the space provided on the directory card.
- d. Fill out remaining information on the directory card in accordance with local procedures.
- e. Install the directory card in the holder provided "Frequently Called Numbers" side up. Refer to Page 3-7.

4. STATION TESTING

After installation the station shall perform as stated in the How To Operate Manual.

PART 3 -- SERVICING
A. TROUBLE ISOLATION AND CORRECTION

QUESTIONS	YES	NO
1. Are any of the three communications mode keys lit? (Power available and set power on.) (Depress other keys if proper key not lit.)	Go to 2.	Go to 1a.
1a. Is there any indication of power in the set? (Lamps flash when power is turned on and off, red lamp on power supply, etc). (See Page 3-7.)	Go to 1b.	Check and replace set fuse (F1) if blown. Replace terminal if fuse blows again. If not blown go to 1b.
1b. Is red lamp on power supply lit?	Check opcon cable connector. (See Page 3-7.)	Check fuse (F2) on power supply. If blown, check for foreign objects between circuit lands or terminals and replace fuse. Replace terminal if fuse blows again.
2. Does printer print test message while the PRINTER TEST key is depressed? (ie, character set printed repeatedly within margin restraints.)	Go to 2a.	Turn off power for several seconds and retry. Replace terminal.
2a. Are any of the following characters substituted in copy? <div style="text-align: center;"> \emptyset \wedge \uparrow $-\leftarrow$ </div>	Check Page 2-1, <u>A. VARIABLE FEATURES</u> , 431.	Go to 2b.
2b. Are undesired line lengths set as follows when power is turned on? <div style="text-align: center;"> 72 80 132 </div>	Check Page 2-1, <u>A. VARIABLE FEATURES</u> , 432.	Go to 2c.
2c. Is printed copy properly aligned with edges of paper? (ie, parallel to edge and not printing on fold or form line.)	Go to 2d.	Check <u>Right Paper Sprocket</u> adjustment and <u>Printed Line Position</u> adjustment.

A. TROUBLE ISOLATION AND CORRECTION (Cont)

QUESTIONS	YES	NO
2d. Is print density acceptable (including any carbons)?	Go to 3.	Replace ribbon. Check proper density multicopy paper.
3. Does terminal have a directly connected modular telephone?	Go to 4.	On-line communications troubles encountered using externally connected data sets and telephones or other arrangements may be insulated by observing signals at the EIA or TTL interface. See Page 2-2, <u>B. INTERFACES</u> .
4. Does AUTO ANSW key light when power is turned on and do LOCAL-TEST, AUTO ANSW and DATA keys each light when depressed?	Go to 5.	Replace terminal.
5. Does telephone operate normally with LOCAL-TALK key lit?	Go to 6.	Check proper connection of modular cords at rear of set. See Page 2-2, <u>B. INTERFACES</u> . Connect phone directly to line. Go to 5a.
5a. Does phone now operate normally?	Check cord that was between phone and terminal. Replace terminal.	Check connections to line and cord between phone and line. Replace phone.
6. When originating a call (answering tone heard) and DATA key depressed, does DATA key light steadily?	Go to 7.	Go to 9.
7. Does phone ring only once and the DATA key light following a received call in the AUTO ANSW mode.	Go to 8.	Originating station must send originating frequency tones, ie, go to DATA mode. Go to 9.

QUESTIONS	YES	NO
8. Are data messages properly sent and received in DATA mode?	Go to 10.	Go to 8a.
8a. Do PARITY, DUPLEX and CPS keys alternately lock down and release up when depressed?	Go to 8b.	Replace terminal.
8b. Does substitute character ■ appear with PARITY key on?	Go to 8c.	Go to 9.
8c. Are both stations operating at same speed, is local copy obtained and is remote station sending even parity?	Go to 9.	Select proper speed and DUPLEX keys. Operate with PARITY switch off or check Page 2-1, <u>A. VARIABLE FEATURES</u> , 434 if remote station is printing the ■ character.
9. Does station echo-back characters (print twice) in ANALOG LOOP-BACK -- HALF DUPLEX mode? (ie, depress AUTO ANSW key, ESC key and shifted key.) (Alarm lamp flashes.)	Remote station may be sending incorrect frequencies or signal levels.	Replace terminal.
10. Does carriage return automatically when line lengths beyond the right margin are received on-line and does station disconnect when EOT is received?	Place in service.	Check Page 2-1, <u>A. VARIABLE FEATURES</u> , 433 or 435. Replace station.

B. PERIODIC CHECKS, LUBRICATION AND CLEANING

1. GENERAL

This part provides routine maintenance procedures for the 43 Teleprinter Basic KSR Station.

A routine maintenance should be performed, at the convenience of the customer, at least once a year.

Routine maintenance consists of visual checks, lubrication, and cleaning. When performed at routine intervals, the possibility of later troubles will be reduced.

Following the routine maintenance, a local and on-line installation checkout should be performed. The routine maintenance date should be filled out on the bottom side of the directory card holder.

2. VISUAL CHECKS

The following areas should be checked for mechanical condition:

- a. Frayed belts on spacing and line feed motors
- b. Worn or frayed ribbon
- c. All cable connectors fully seated (Page 3-7).
- d. Print head cover fully seated.

3. CLEANING AND APPEARANCE

Examine exterior areas for smudges, dust, etc.

Check proper fit of cover. Replace extremely damaged or discolored cover, housing, bustle, etc.

Exterior cleaning should normally be limited to wiping with a soft cloth moistened with a mild detergent. However, in case of ink stained plastic surfaces, a waterless (nonabrasive) hand cleaner or a lather from abrasive bar soap applied with a cloth should be used.

Interior areas should be examined with the cover opened and accumulations of paper dust or ribbon fragments cleaned by carefully brushing loose material onto a cloth. Ink stains or deposits on interior surfaces, ribbon rollers, platen, etc, can be wiped with a cloth dampened in mineral spirits.

WARNING: DO NOT ALLOW MINERAL SPIRITS OR SOLVENTS TO CONTACT EXTERIOR PLASTIC SURFACES.

4. LUBRICATION PROCEDURES

The printer can be lubricated by opening the cabinet cover. Apply lubricant to points as indicated.

On small parts, a minimum amount of lubricant should be applied so that the lubricant remains on the parts and does not run off.

Excessive lubricant should be removed with a dry, lint-free cloth.

The following areas must be kept dry, free of all lubricant: All electrical components, including terminals. All parts normally touched by the operator, including exposed surfaces in ribbon, paper handling areas, and all large flat areas.

The following symbols indicate the quantity of lubricant to be used in a specified area: Symbols O1, O2, O3, etc, refer to 1, 2, 3, etc, drops of oil.

The following list of symbols applies to the lubrication instructions and the type of lubricant to be used:

- O Oil 88970 (1 qt), 88971 (1 gal), 318775 (4 oz).
- G Apply thin film of 97116 (4 oz) or 88973 (no. 1) grease.
- S Saturate felt oilers, washers, and wicks with oil.
- D Keep dry, no lubricant permitted.

Lubrication Checklist: (See Page 3-6.)

Lead Screw -- Film of grease over entire threaded portion of lead screw.
 Carriage Wicks -- Saturate with oil (4 places)
 Ribbon Rollers -- 2 drops of oil (4 places)
 Ribbon Tension Arm Pivot and Spring -- 2 drops of oil each (4 places)
 Spacing Tension Arm Pivot, Roller and Spring -- 2 drops of oil each (4 places)
 Platen Bearing -- 5 drops of oil each side (2 places)
 Finger Pivots -- 2 drops of oil each side (2 places)
 Paper-Out Arm Pivot -- 2 drops of oil on both pivot points.
 Lead Screw Pulley Clip -- Grease between clip and lead screw shaft.

Carriage and Nut Engaging Surfaces:

- Two nut drive arms -- Grease four bearing surfaces.
- Nut keying arm -- Lubricate by packing carriage engaging slot with grease.

B. PERIODIC CHECKS, LUBRICATION AND CLEANING (Cont)

5. LUBRICATION POINTS

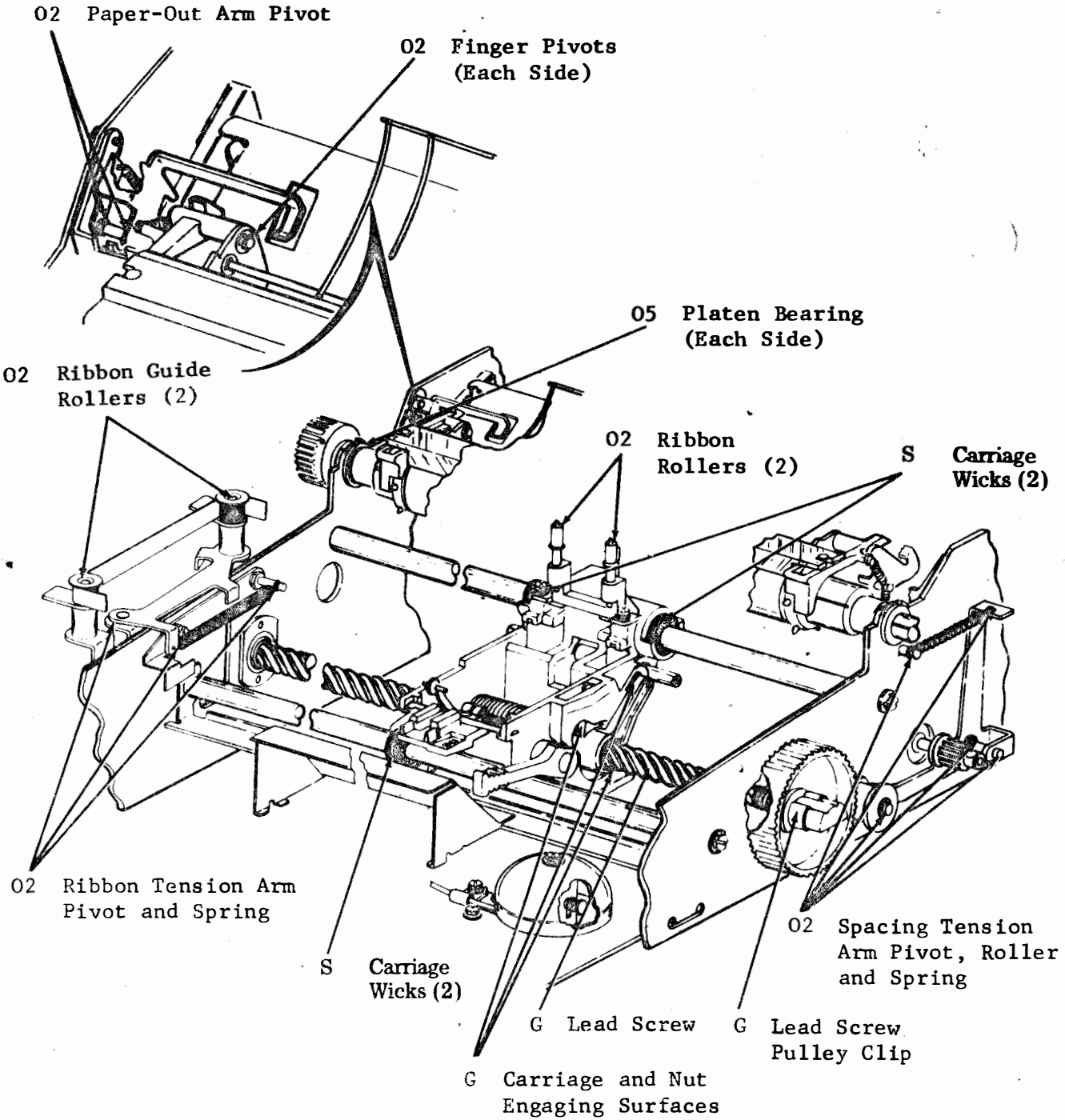

C. COMPONENT ACCESS

1. Operator Console (Opcon), Cables, Directory Card and Variable Feature Switch

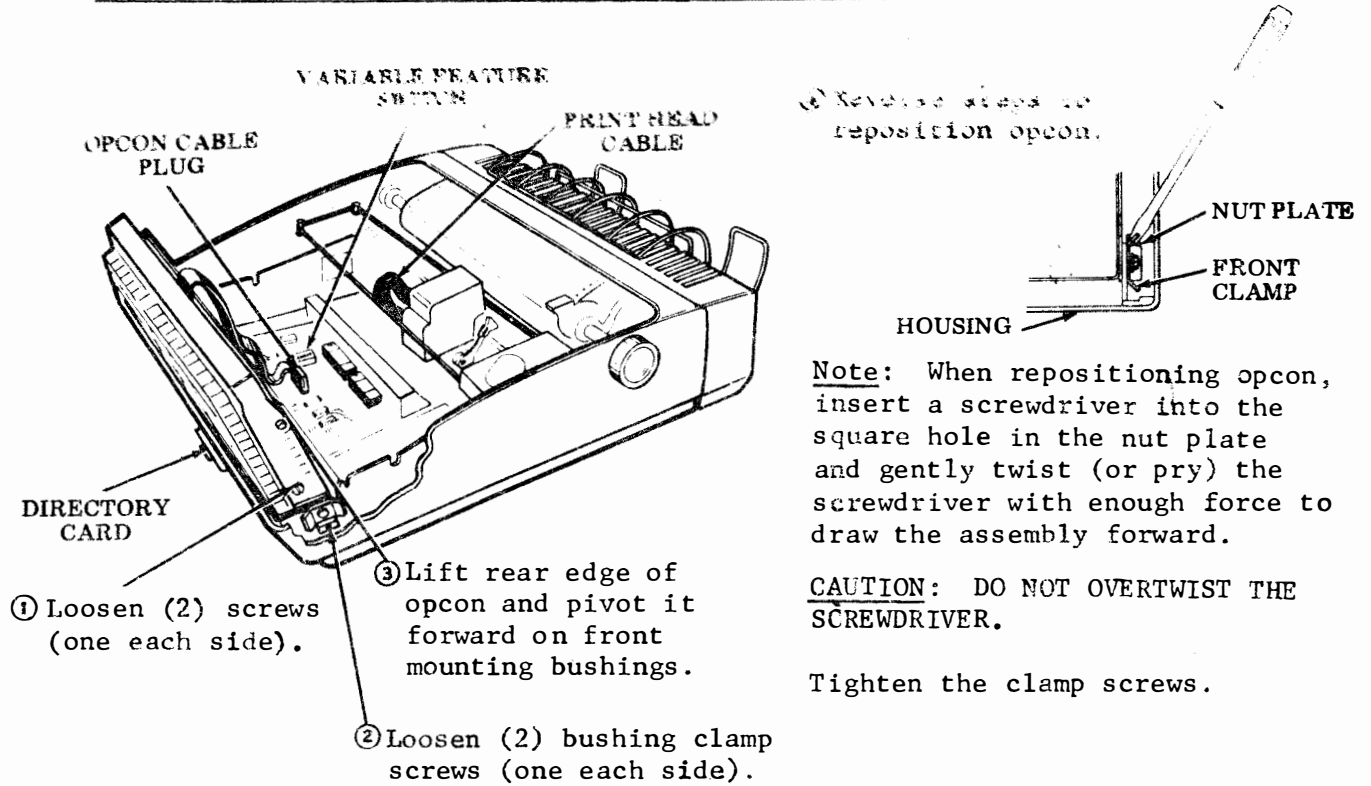

2. Power Supply Lamp, Cables and Fuses

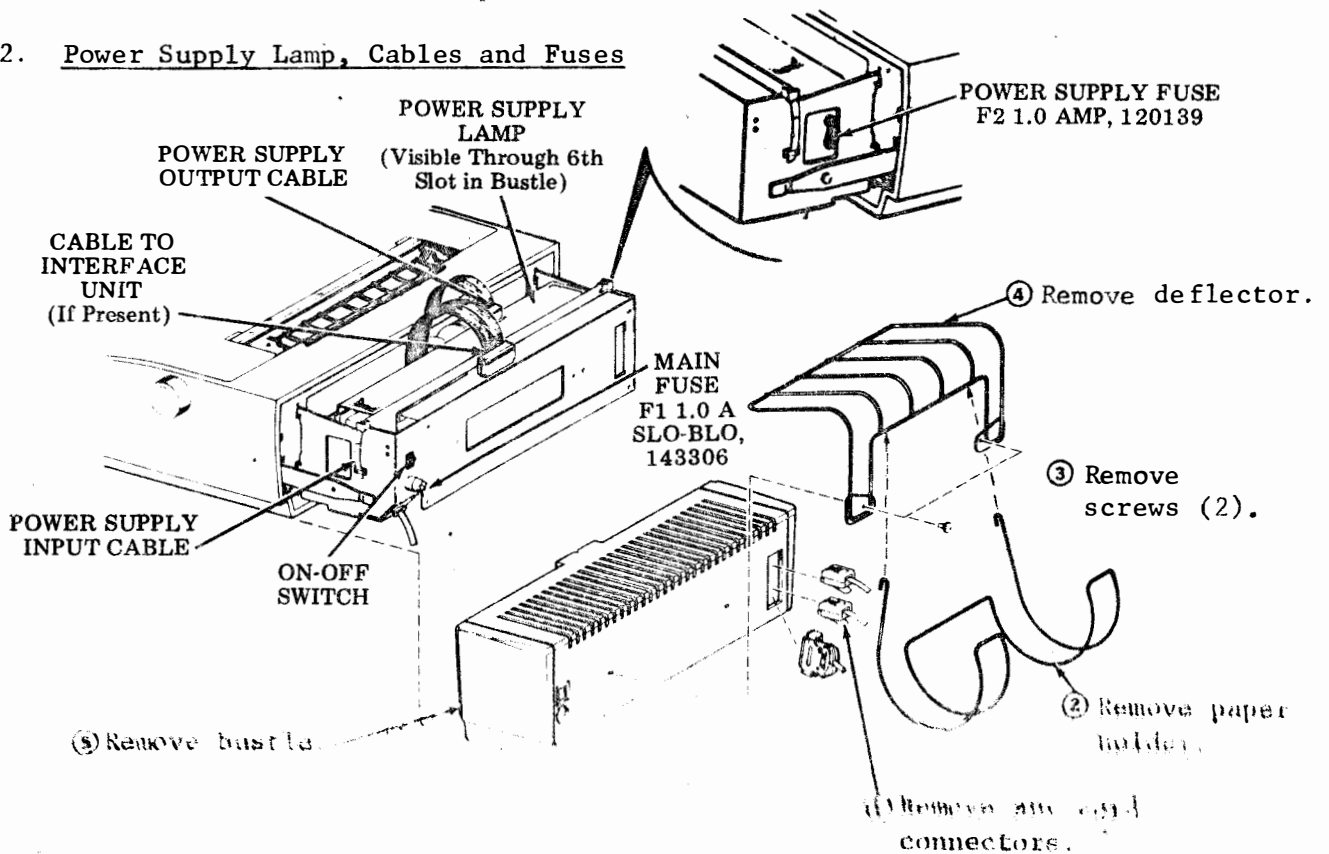

D. ADJUSTMENTS1. RIGHT PAPER SPROCKET

Requirement: The right sprocket shall be biased against the collar of the platen hub and the pins shall be in line with the pins of the left sprocket.

To Adjust: Loosen setscrews and position right sprocket to meet requirement.

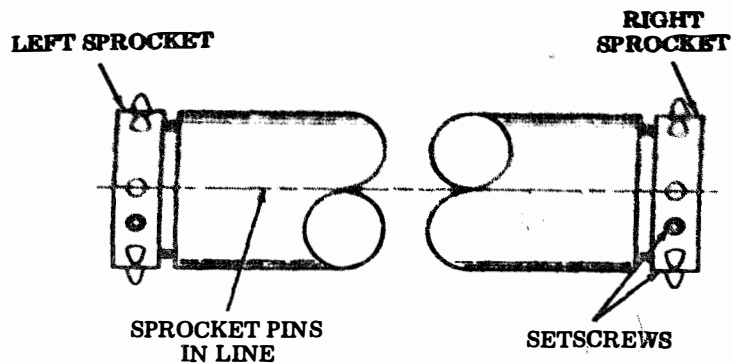
2. PLATEN ENDPLAY AND PRINTED LINE POSITION

The following 2 requirements must be met:

Requirement (1): Platen Endplay
With the platen biased against the left bearing there shall be some to 0.008 inch clearance between the bearing and the sprocket.

Requirement (2): Printed Line Position
The lower edges of a typed line shall be $\frac{1}{32} \pm \frac{1}{64}$ inch above a horizontal line drawn even with the bottom edge of any sprocket hole. If horizontal ruled lines are provided on which typing is to be done, the lower edges of a typed line shall be even with, or a multiple of $\frac{1}{6}$ inch from the bottom of any sprocket hole within a tolerance of $\pm \frac{1}{64}$ inch. (Power must be on line feed motor for this adjustment.)

To Adjust: Loosen the line feed sprocket (at platen) setscrews and position. Print the character "M" across the line and check Requirement (2). If necessary, loosen setscrew on right sprocket to meet alignment requirement.

