

*Bulletin No. 3  
Issue 1  
November, 1932*

# TELETYPESETTER

*DESCRIPTION  
OF THE  
KEYBOARD TAPE PERFORATOR*

**RTTY  
ELECTRONICS**  
**TELETYPE**  
SALES - SERVICE - PARTS  
P.O. BOX. 20101 EL SOBRANTE, CA.  
94820  
PHONE (510) 222-3102  
mr\_rtty@pacbell.net

**TELETYPESETTER**  
CORPORATION  
1400 WRIGHTWOOD AVE.,  
CHICAGO, U. S. A.

**Property of Wilbur F. Porter**

keylevers and four sets of counting selector bars.

The notches in the forward ends of the counting code keylevers fit over studs on the character keylevers (Fig. 7). The rear ends of the counting code keylevers are pivoted on the shift ball. A detent (if provided) to hold the shift ball in either the lower or upper case position. A red and white assembly, located on the pointer mechanism, is operated in combination with the shift ball through the linkage of levers. White indicates lower and red upper case position.

When a keylever is depressed, the counting code keylevers will be moved down against the counting selector bars. The combination set up in these selector bars is determined by the notch on the lower surface of the counting code keylevers. It should be noted that the perforating mechanism is somewhat similar to that of the perforating mechanism, except that the notches are located on the counting code keylevers instead of on the selector bars.

The "SHIFT" and "UPPER" keys control the position of the shift ball, making it possible to change the counting selection (by shift) for the relationship of the counting code keylever notches to that of the counting code bars for upper and lower case characters. By this change in the selection, the counting mechanism will be advanced the proper amount corresponding to the width of either the upper or lower case characters.

The four sets of counting selector bars, used with the counting mechanism, provide a possibility of sixteen combinations. The counting selector bar assembly (which includes the levers and links) are

TELETYPESETTER  
PATENTS APPLIED FOR

OFF  
ON



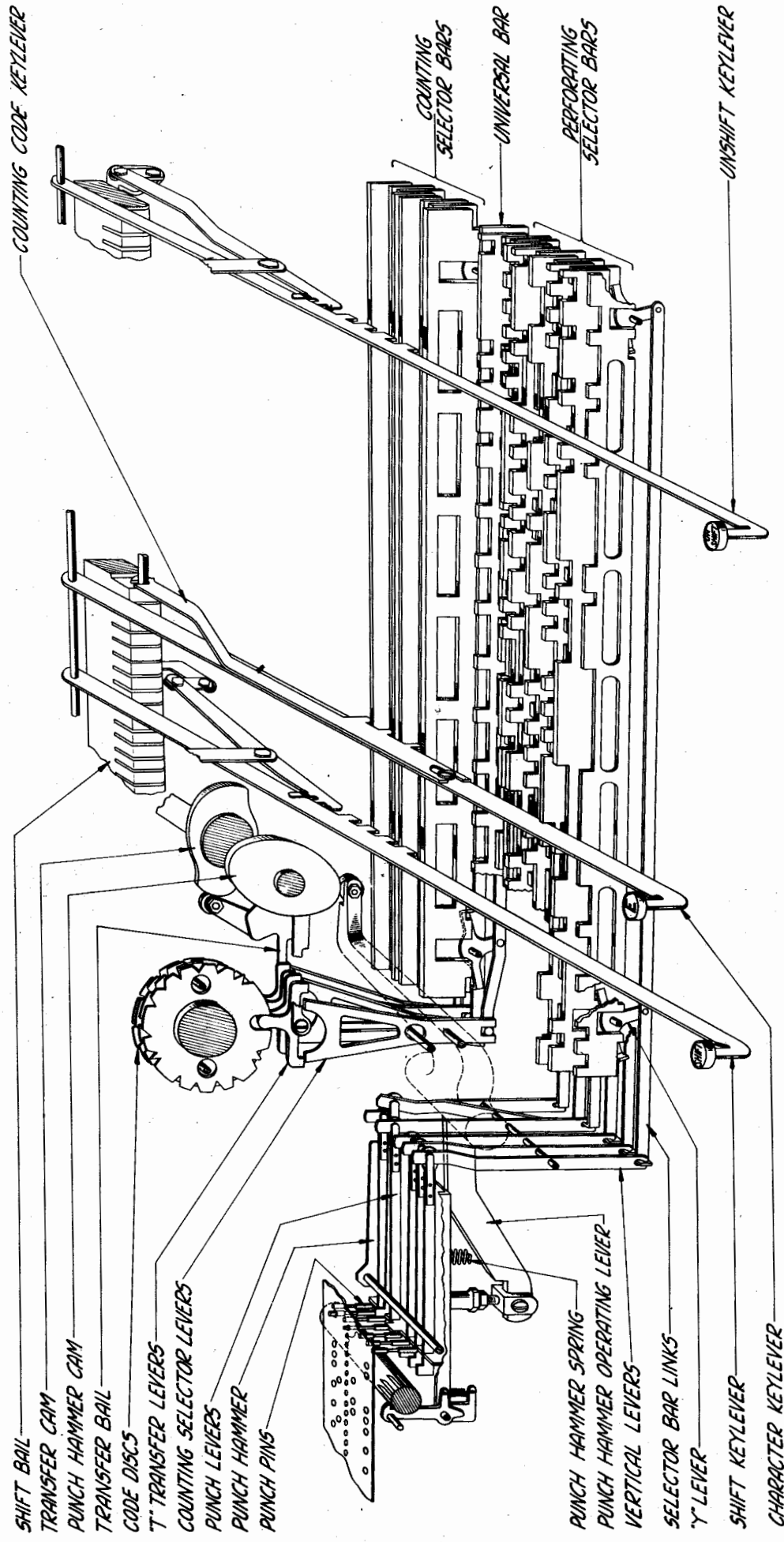

FIGURE 1



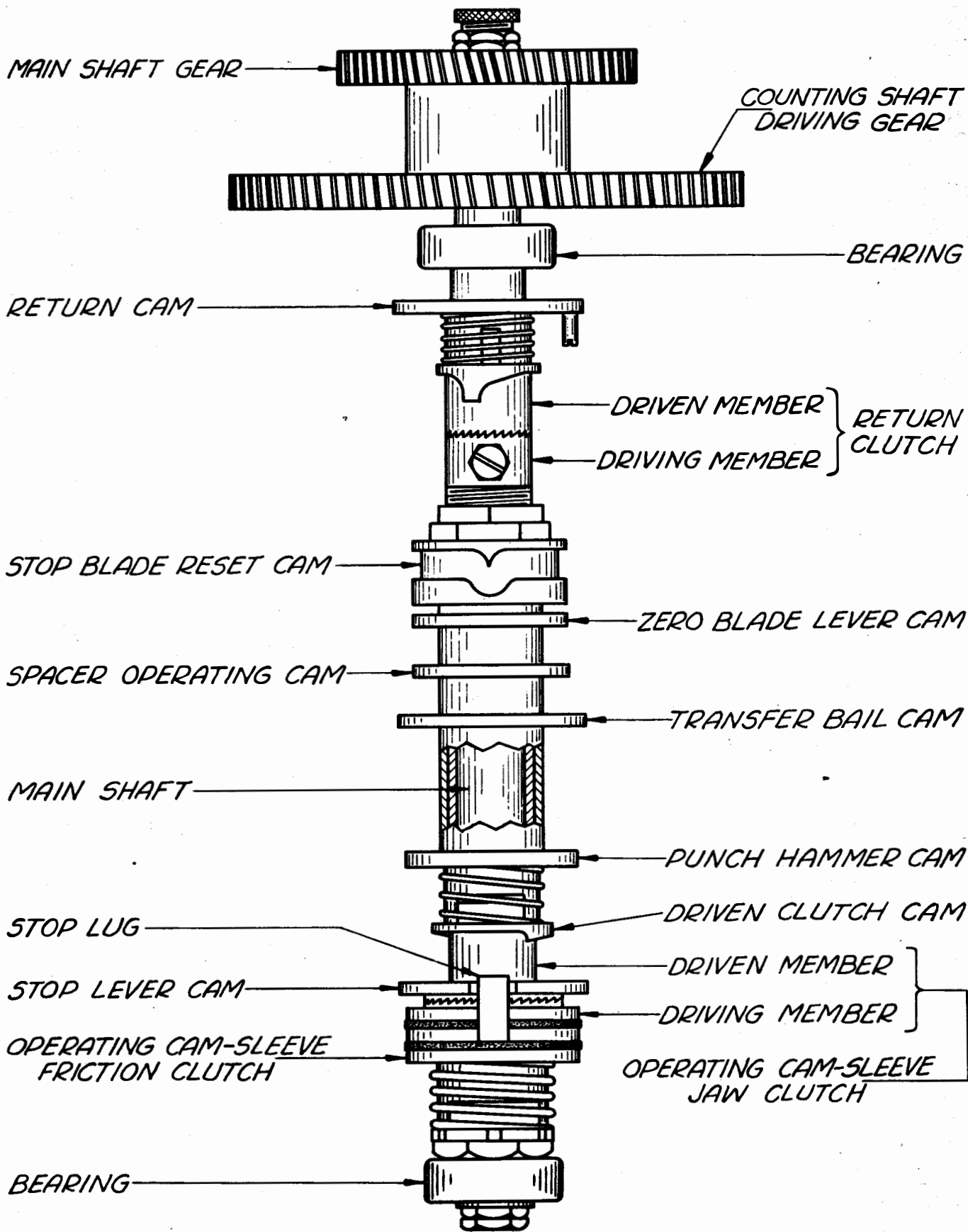

FIGURE 3

both ends so that they may be moved upward or downward. The perforating selector bars are provided with notches on their upper edges according to the requirements of the code. The notches in the front and rear perforating selector bars of each pair are staggered so that there will always be a high portion on either one of the pair in the path of each keylever. The ends of each pair of perforating selector bars rest on the arms of "Y" levers, the front perforating selector bars resting on the left arms of the "Y" levers, while the rear bars rest on the right arms.

When a keylever is depressed, those perforating selector bars having their high portions in line with that keylever, are moved down. This causes the "Y" levers to move the other selector bar of each pair up. Should the rear one of any pair of selector bars be moved down, the lower extensions of the corresponding "Y" levers will be moved to the left; and to the right when the corresponding front selector bars are moved down. Thus it may be seen that the links which are connected to the ends of the lower extensions of the "Y" levers will be moved to the left when the rear selector bar is moved down and to the right when the front selector bar is moved down.

The left ends of the links are engaged in the lower ends of vertical levers. The upper ends of the vertical levers are connected to the punch levers. When the links are moved to the left, the punch levers will be moved to the right and their high portions (located at the extreme left end) will be positioned in the path of the punch pins that are to be selected to perforate the tape.

### Main Shaft Functions

The power for operating the perforating and counting mechanism is supplied by the motor. The motor pinion meshes with the main shaft gear which is mounted on a hub attached to the rear end of the main shaft (Fig. 3). The counting shaft driving gear (mounted on the same hub with the main shaft gear) drives the counting shaft so that the two shafts will be caused to revolve continuously. The main shaft assembly includes the operating cam sleeve friction and jaw clutches, operating cam sleeve, return clutch and the return cam. The operating cam sleeve friction clutch is located at the forward end of the main shaft and consists of two steel discs keyed to the shaft, two felt washers and a clutch friction disc. Two stop lugs on the clutch friction disc engage notches in the stop lever cam which is part of the

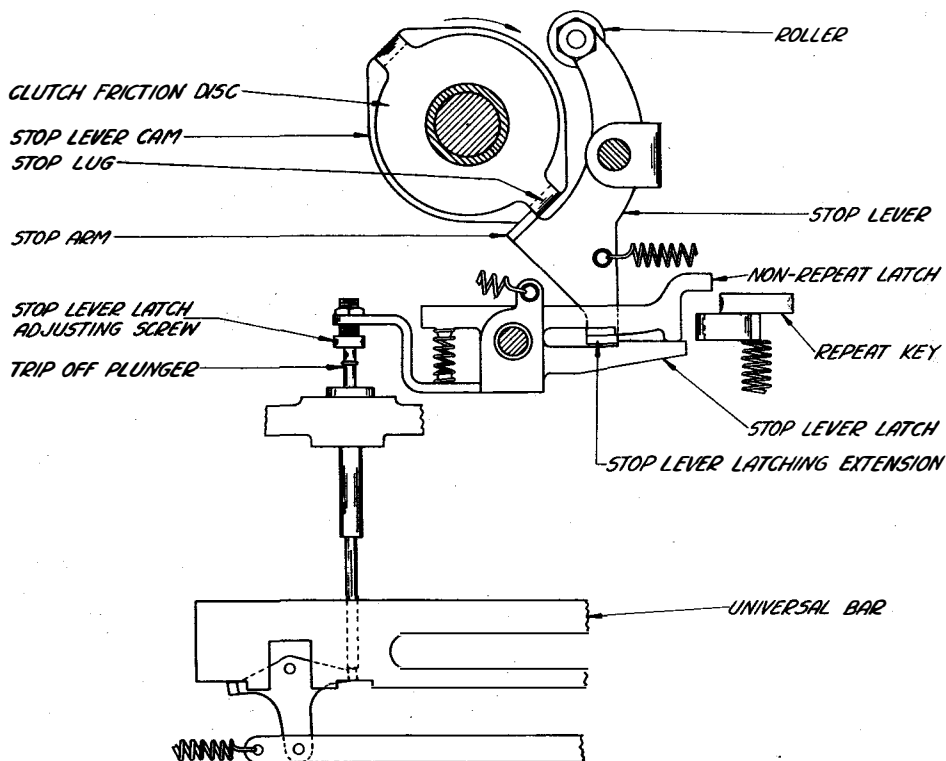

FIGURE 4.

operating jaw clutch driven member (Fig. 4). Prongs on the rear end of the driven clutch member engage slots in the operating cam sleeve assembly (Fig. 3). Normally the cam sleeve assembly is held stationary because the latching extension of the stop lever is engaged by the stop lever latch (Fig. 4) and the stop arm on the stop lever is against the stop lug on the friction disc. Thus it may be seen that when the friction disc is permitted to revolve the operating cam sleeve will also revolve.

At the same time that the selector bars are being positioned by depressing a key-lever, the universal bar is moved down against the tension of a spring. The right arm of the "Y" lever, located at the left end of the universal bar will move the trip-off plunger upward against the left end of the stop lever latch (Fig. 4). The right end of the latch will then move down out of engagement with the stop lever latching extension. The stop lever spring in turn pulls the stop lever out of engagement with the lug on the clutch friction disc, permitting the cam sleeve assembly to revolve. After the cam sleeve assembly has revolved a few degrees, the driven clutch member will be permitted to mesh with the driving member (Fig. 3) and the cam sleeve will be rotated through the medium of the jaw clutch. It should be noted that two friction clutch stop lugs are provided so that the operating cam sleeve will be stopped twice during each revolution and the cams on the operating cam sleeve are arranged to perform their various functions during each half revolution. Near the end of the one-half revolution, the driven clutch member will be cammed out of mesh with the driving member. As the stop lever roller rides up onto the high portion of the stop lever cam, the stop lever latching extension is moved toward the left into engagement with the stop lever latch (Fig. 4).

The non-repeat latch is provided to prevent a selection being perforated more than once with each operation of a keylever regardless of the length of time a keylever is held down (Fig. 4). Should the keylever be held depressed for a period longer than that required for one-half revolution of the cam shaft, the stop lever latching extension will engage the notch in the non-repeat latch and the clutch stop lever will be held in the path of one of the friction disc stop lugs. When the key-lever is released, the stop lever latch will move the non-repeat latch upward out of engagement with the stop lever latching extension which permits the stop lever to move into engagement with the stop lever latch.

As the cam sleeve revolves, the roller on the right end of the punch hammer operating lever (Figs. 1 & 5) will ride onto a high part of its cam, moving the left end of the lever upward. The punch hammer, which is engaged with the plunger that is attached to the left end of the operating lever, will also be moved upward (against the tension of its spring) carrying with it the punch levers. The selected punch levers (those which have been moved to the right and have their high portions in line with the punch pins) will drive the corresponding die block punch pins through the tape. An extension is provided on the punch hammer beneath the tape feed hole die block pin, so that with each operation of the punch hammer, a feed hole will be perforated.

The punch hammer operating lever roller will now ride down onto a low portion of the operating cam, permitting the punch hammer spring to pull the punch hammer downward to the normal unoperated position. This will also permit the die block pins to be withdrawn from the tape.

#### Tape Feed Mechanism

The tape feed roll is located to the left of the die block (Figs. 1 & 5). Spaced at equal intervals around the feed roll is a series of projecting feed pins which mesh with the feed holes punched in the tape. A tape tension lever holds the tape against the feed roll, keeping the feed holes in the tape in constant mesh with the tape feed pins.

During the upward movement of the punch hammer, the feed pawl, which is attached to the punch hammer, engages another tooth on the tape feed roll. When the punch hammer moves downward, the tape feed roll will revolve, advancing the tape one character space. The star wheel and detent are provided to insure an equidistant spacing of the tape.

#### Back Space Lever

The back space lever is provided so that any operator's errors may be corrected in the tape before it is used to operate the slug line casting machine. The back



space lever moves the tape backwards. The rubout key may then be depressed, causing six holes to be perforated over the error. This combination may be passed through the operating unit without performing any function on the slug line casting machine.

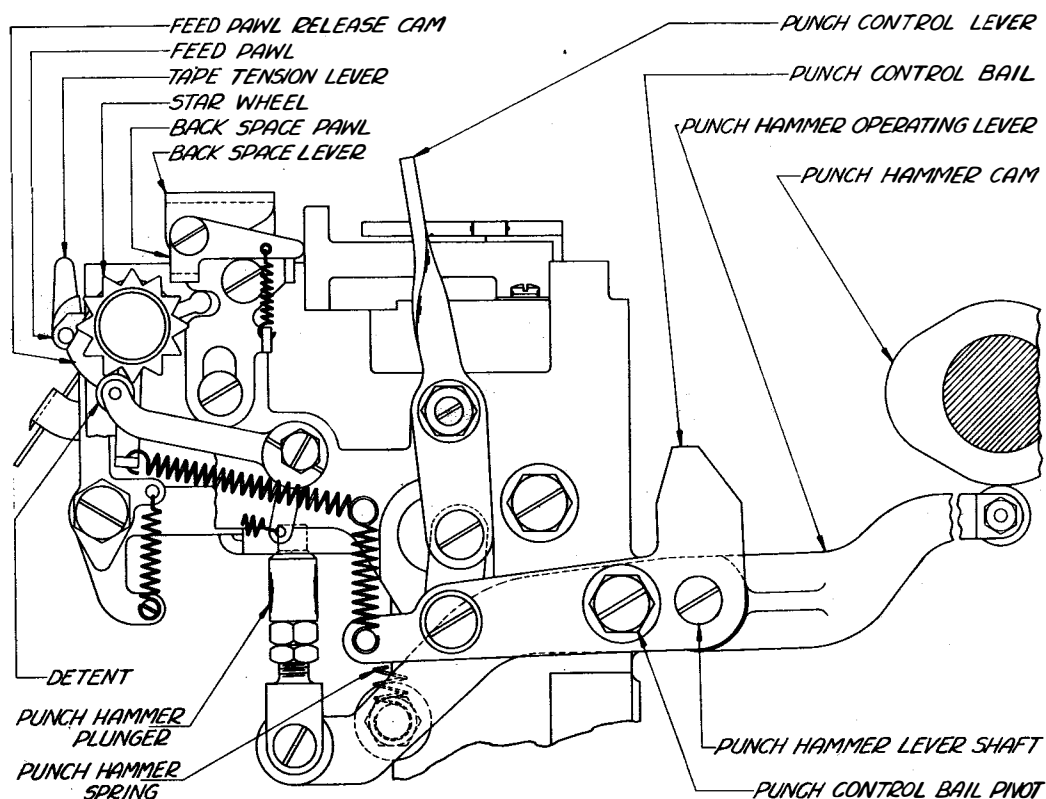

FIGURE 5.

As the back space lever is moved downward (Fig. 5), the feed pawl release cam moves the feed pawl out of engagement with the feed roll ratchet. Then the back space pawl engages a tooth on the star wheel rotating the tape feed roll backwards one character space.

### Punch Control

The manually operated punch control is provided so that the operator may make a trial line to determine the exact length required for the text to be set up without perforating the tape.

The punch hammer operating lever is pivoted on the punch hammer lever shaft which is located at the right hand end of the punch control bail (Fig. 5). With the punch control lever to the left (normal operating position), the left end of the punch control bail is held down and the punch hammer lever will be positioned so that its roller will ride against the punch hammer lever operating cam.

When the punch control lever is moved to the right, the left end of the punch control bail will be pulled upward by its spring. The punch hammer lever cam roller will then be moved down out of the path of its cam.

### COUNTING MECHANISM

The counting mechanism advances the counting pointer the required amount to correspond with the width of the letter or character to be set up in the slug line casting machine. This is accomplished by means of a selecting mechanism through the medium of counting code keylevers and four sets of counting selector bars.



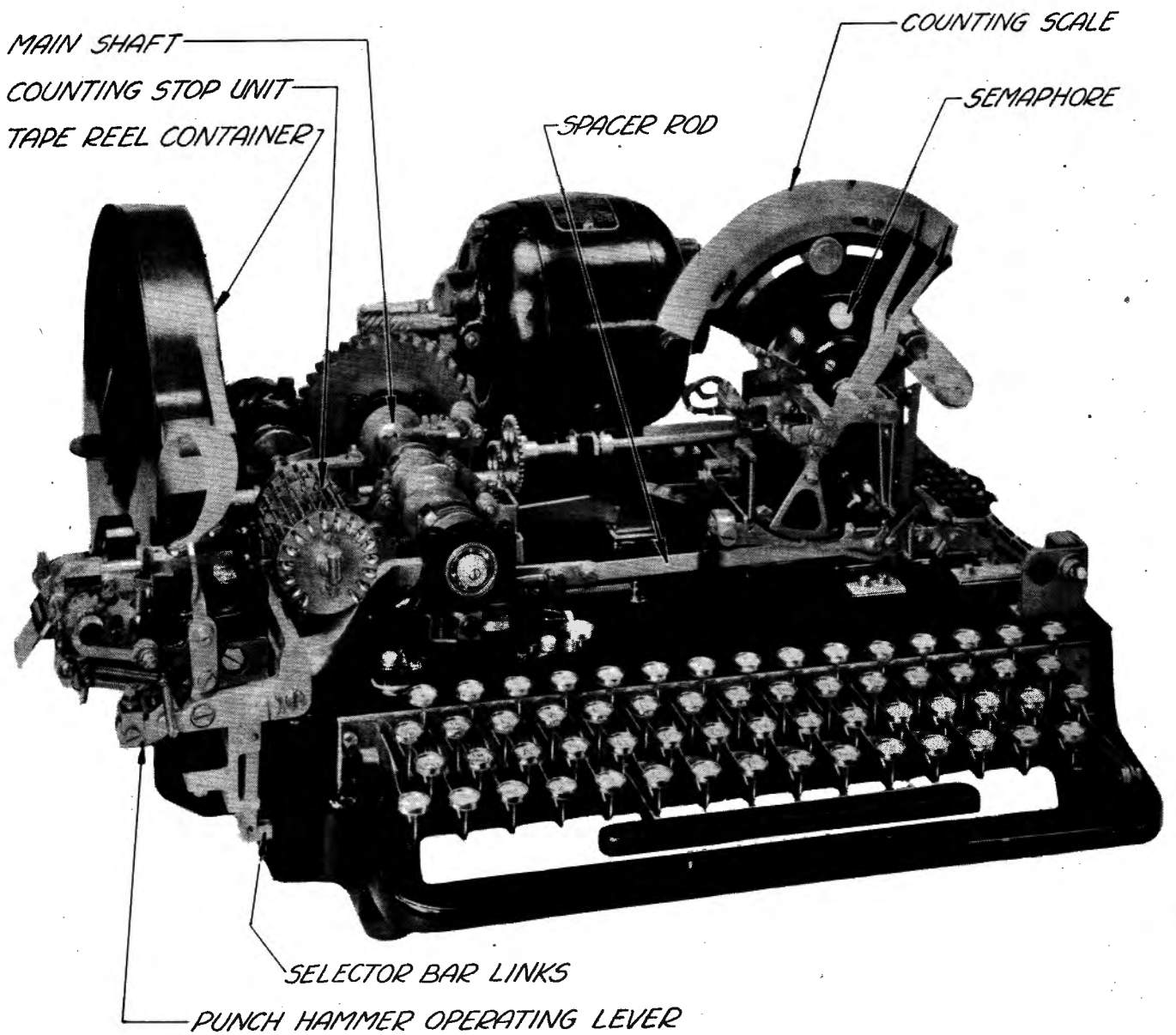

*ILLUSTRATION A*

The notches in the forward ends of the counting code keylevers fit over studs on the character keylevers (Fig. 1). The rear ends of the counting code keylevers are pivoted on the shift bail. A detent is provided to hold the shift bail in either the lower or upper case position. A red and white semaphore (Illus. A) located on the counter bracket is operated in conjunction with the shift bail through the medium of levers. White indicates lower case position and red indicates upper case.

When a keylever is depressed, the counting code keylevers will be moved down against the counting selector bars. The combination set up in these selector bars is determined by the coding on the lower surface of the counting code keylevers. It should be noted that the method of selection is somewhat similar to that of the perforating selecting mechanism, except that the notches are located on the counting code keylevers instead of on the selector bars.

The "SHIFT" and "UNSHIFT" keys control the position of the shift bail, making it possible to change the counting selection (by shifting the relationship of the counting code keylever notches to that of the counting code bars) for upper and lower case characters. By this change in the selection, the counting mechanism will be advanced the proper amount corresponding to the width of either the upper or lower case characters.

The four sets of counting selector bars, used with the counting mechanism, provide a possibility of sixteen combinations. The counting selector bar assembly (which includes "Y" levers and links) is arranged similarly to that of the perforating selector bar assembly. The left ends of the links engage the counting selector levers.

When a keylever is depressed, in addition to setting up code combinations on the punch levers, code combinations are also set up on the selector levers of the counting mechanism.

At about the time the punch hammer operating lever roller is on a high part of its cam (when the tape is being perforated), the transfer bail roller is also on a high part of its cam. When the "T" transfer levers (which are pivoted on a shaft attached to the transfer bail) are moved down against the counting selector levers, the "T" transfer levers will position themselves to correspond with the selection set up (Fig. 1). The upper extensions of the "T" transfer levers (which engage in the notches of the code discs) will in turn transfer this selection to the code discs by rotating them either clockwise or counter-clockwise to correspond with the selection. The four code discs, which are part of the counting stop unit, have a series of notches in their outer edges. Equally spaced around the circumference of the code discs are sixteen stop pins (Fig. 6). These pins are held in slots in three guide discs and are pulled against the edges of the discs by springs. With the code discs set in any particular combination, their notches will be lined up so that the selected stop pin will be permitted to move toward the center. The stop pins fit into the notches of stop pin plungers so that a selected stop pin will move its plunger into the path of one of nineteen stop blades.

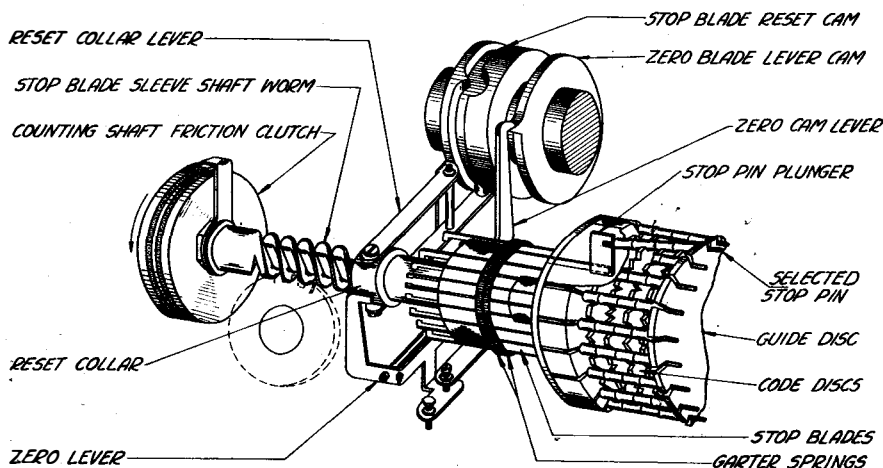

FIGURE 6

These nineteen stop blades are fitted into grooves in a sleeve located to the rear of the code discs. The blades are held in the grooves and are detented in their front and rear positions by two garter springs.

At practically the same time as the transfer bail starts moving downward, the zero cam lever rides up onto a peak of its cam. The lower end of the zero cam lever will then move against the zero lever, the upper extension of which will push the stop blade opposite it to its forward position. This stop blade will be held in its forward position by the detenting action of the garter springs. The zero cam lever will then ride onto the low portion of its cam, permitting the zero lever to be moved away from the stop blades by a spring. While the zero lever is moving the stop blade forward, the reset collar is resetting the previously selected stop blade, the reset collar being actuated by the reset collar lever roller moving onto the high portion of the stop blade reset cam (Fig. 6). The stop blade that is being moved forward by the zero lever is not affected by the movement of the reset collar, however, because of a notch in the collar at the zero position. When the stop blade that is being reset has been moved far enough by the reset collar to clear the stop pin plunger, the counting shaft friction clutch will rotate the stop blade sleeve shaft until the stop blade (which was just moved forward by the zero lever) strikes the selected stop pin plunger.

The distance that the stop blade sleeve shaft rotates is determined by the character selected and will be indicated on the counting scale by the movement of the counting pointer. Thus the counting pointer (Fig. 7) is advanced by the rotation of the stop blade sleeve shaft worm (Fig. 6) through a chain of gears an amount that will correspond to the width required for that character.

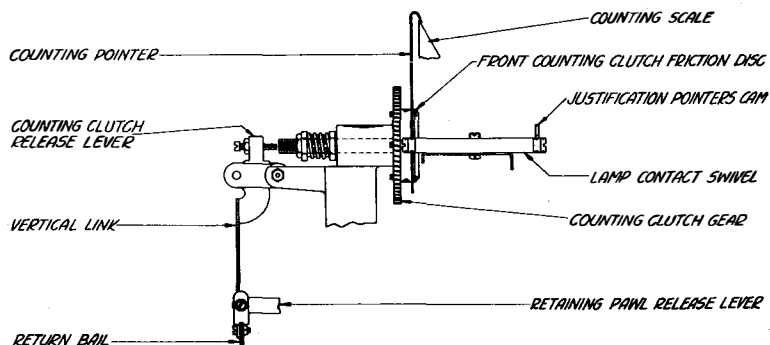

FIGURE 7

When any function key is depressed, the #1 stop pin and plunger is selected on the counting stop unit. The #1 stop pin plunger is located next to the zero stop blade position. When a character follows a function, the stop blade previously selected for the function will not be reset by the reset collar (because of the notch at this point) but it will be used again instead of the stop blade set up by the zero lever to determine the stopping point of the stop sleeve shaft. Therefore, the distance traveled by the sleeve in cases of this kind (when a character follows a function) is equivalent to the distance required for that character less the distance previously traveled for the function.

### Justification Pointers

In addition to the counting pointer, two justification pointers are provided to indicate the range of space band expansion on the slug line casting machine (Fig. 8). They operate in conjunction with the counting mechanism and are normally held by their springs opposite the zero position on the counting scale. The justification pointers are operated by the spacer operating cam through the medium of the spacer bail, spacer rod, justification pointers ratchet (Fig. 9), and gear segments meshed with teeth on the lower ends of the pointers (Fig. 8). The operation of the pointers, however, is controlled by the space bar.

When the space bar is depressed, in addition to setting up the combinations in the perforating mechanism, an extension on the space bar lever moves the justification pointers feed pawl into engagement with the justification pointers ratchet through

the intermediate pawl and intermediate pawl latch, mounted on the spacer rod. At practically the same time as the tape is being perforated, the spacer bail roller is riding up onto the high part of the spacer operating cam and the spacer rod, which is attached to the spacer bail, will be moved towards the left. The justification

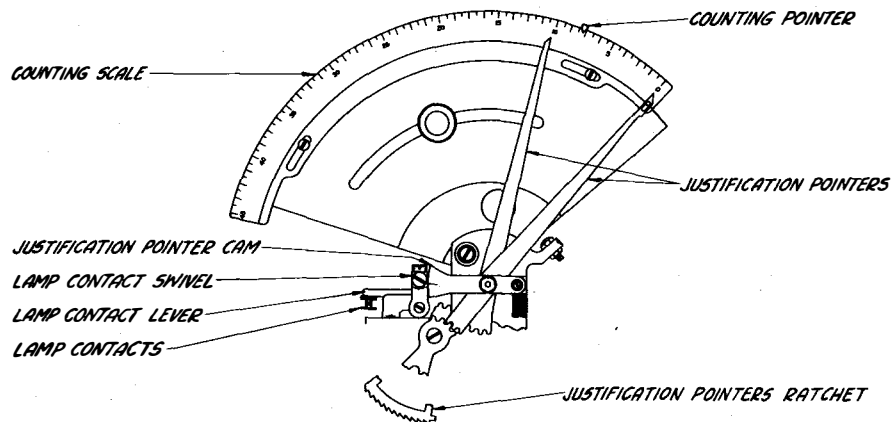

FIGURE 8.

pointers feed pawl will in turn advance the justification pointers ratchet one tooth. Thus the right hand justification pointer and scale will be moved a distance equivalent to the minimum thickness of the adjustable space bands and the left hand pointer a distance equivalent to the widest spacing. Near the end of the left stroke of the spacer bail rod the reset extension on the intermediate pawl is moved against the reset lug, bringing the upper extension of the intermediate pawl into engagement with its latch. The retaining pawl holds the justification pointers ratchet while the feed pawl is being advanced to the next tooth on the ratchet.

#### End-of-Line Signal Lamp

A signal lamp is provided to warn the operator when approaching the end of the line (Fig. 8). The circuit to the lamp is closed at approximately the time when the counting pointer is opposite the left hand justification pointer. This is accomplished by a pair of contacts that are controlled by cams which form a part of the counting pointer and the left hand justification pointer. The lamp contact swivel rollers are held against the counting and left justification pointers cams by the lamp contact lever spring. As the counting pointer moves toward the right and the left justification pointer toward the left, the high portions of their cams will move the swivel toward the left and the lamp contact lever which is attached to it will move down, closing the lamp contacts.

#### Carriage and Pointers Return ("Ret" Key)

Normally the driven member of the return clutch, located to the rear of the main shaft, is held out of engagement with the driving member by the return clutch throw-out lever (Fig. 9). When the "Ret" (return) key is depressed, an extension on the keylever pulls the right end of the return actuating lever down. The clutch throw-out lever trip-off pawl, which is attached to the left end of the return actuating lever, will move the clutch throwout lever out of engagement with the stop lug on the driven clutch member. The return clutch spring will move the driven cam member into engagement with the driving member, causing the return cam to be revolved. The return bail roller (attached to the left end of the return bail) will ride up onto the high portion of the return cam, moving the counting pointer clutch release lever forward through the medium of the vertical link which connects the right end of the return bail to the counting clutch release lever.

The end of the shaft which forms a part of the front counting clutch friction disc (Fig. 7) is engaged with the adjusting screw on the upper end of the counting clutch release lever. Therefore, when the counting pointer clutch release lever is moved forward, the front friction disc will remove the tension on the counting pointer disc, allowing the counting pointer spring to return the counting pointer to its starting position. This position is adjustable and may be moved to the various pica widths of the column to be set up.

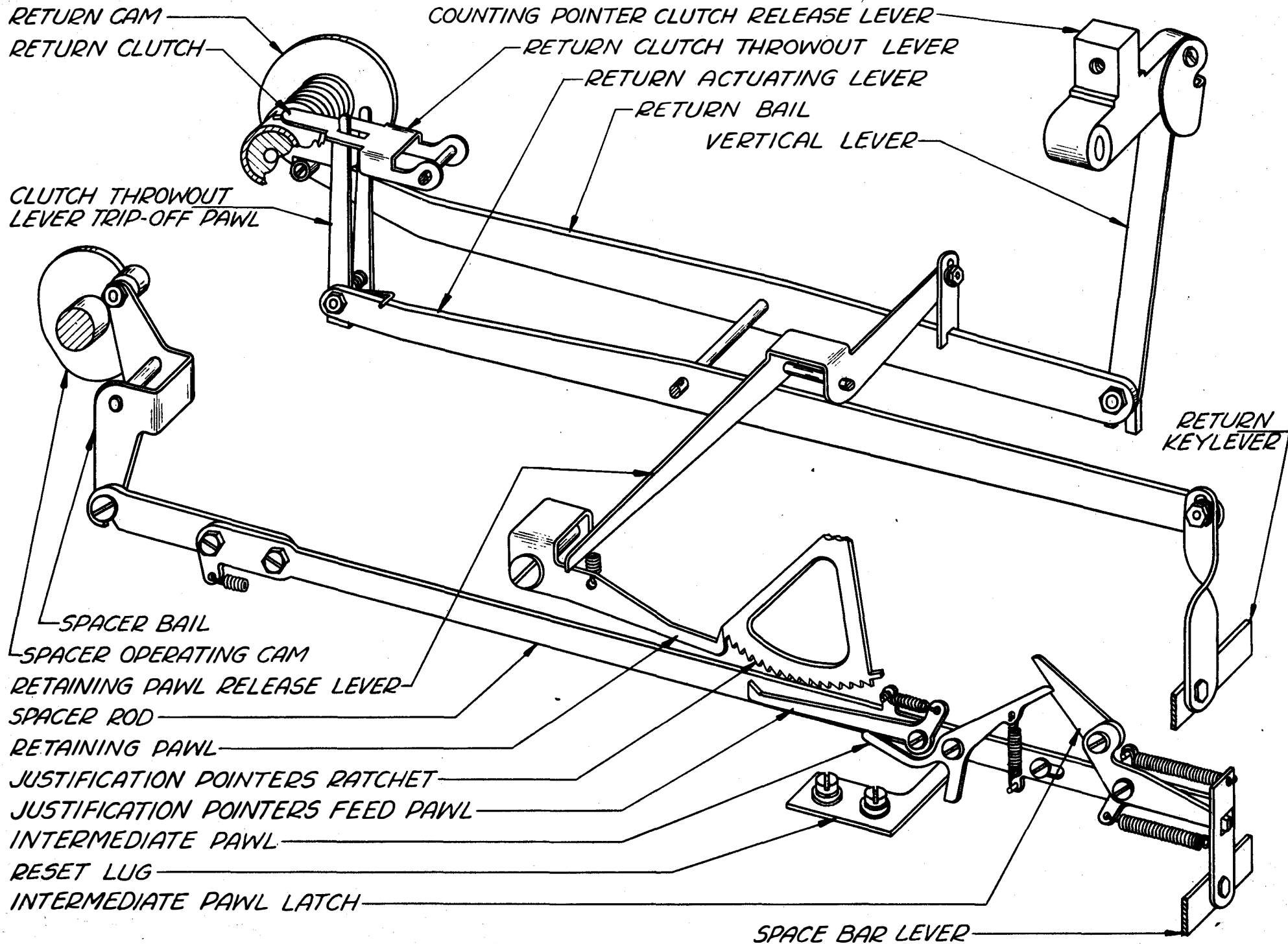

FIGURE 9

A vertical link attached to the rear end of the retaining pawl release lever engages the return bail (Fig. 9). At the same time the right end of the return bail moves up to disengage the counting clutch, the front end of the retaining pawl release lever will be moved down against the retaining pawl, disengaging it from the justification pointers ratchet. The justification pointers will also be returned to their zero position by their springs.

Near the end of each revolution of the return cam, a stud which is attached to the cam will move against the rear extension of the clutch throwout lever trip-off pawl. Should the "Ret" (return) key be held depressed, the return clutch throwout lever will be held out of engagement with the stop lug on the clutch driven member until the return cam stud moves the trip-off pawl out of engagement with the clutch throwout lever. In this way, only one revolution of the return cam is permitted each time the "Ret" (return) key is depressed.

#### REPEAT KEY

When the "RPT" (repeat) key is depressed in conjunction with any other key, it provides continuous operation of that character or function. In operating practice this feature is used to facilitate the spacing out of the tape and perforating a series of rubouts. This is accomplished by the rear extension of the repeat key moving up against the non-repeat latch, raising it out of the path of the clutch stop lever.

#### WIRING

Wiring Diagram #1447 on the following page shows the theoretical wiring of a typical Keyboard Tape Perforator. The upper diagram shows the wiring of a direct current unit and the lower diagram shows the alternating current unit. Refer to actual wiring diagram for complete circuits.

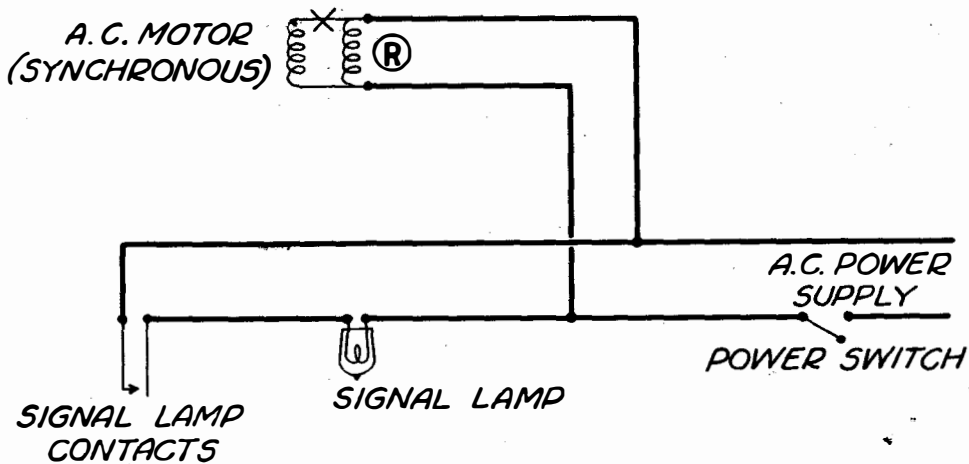
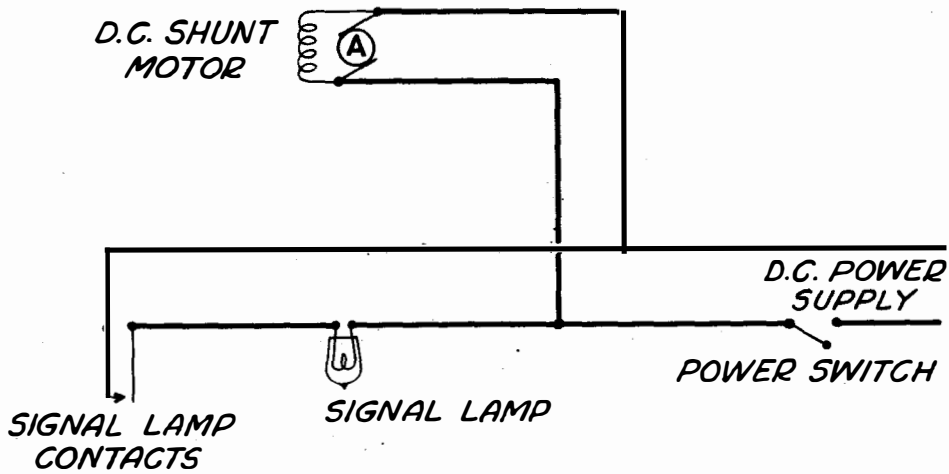

TELETYPESETTER CORPORATION

1447

THEORETICAL WIRING DIAGRAM

TELETYPESETTER KEYBOARD TAPE PERFORATOR

DRAWN *Rue*  
 TRACED  
 CHECKED *E.P.K.*  
 ENG'R'D  
 APPROVED *J.C.P.*