

28 PERFORATOR-TRANSMITTER BASE

ADJUSTMENTS

CONTENTS	PAGE	CONTENTS	PAGE
1. GENERAL . . . . .	1-3	Synchronous motor positioning . . . . .	26
2. BASIC UNIT . . . . .	4	Keyboard Mechanism	
Codebar Assembly		Ball wedgelock, ball endplay, and universal bail latch (final) . . . . .	14
Clutch tripbar spring . . . . .	8	Ball wedgelock and ball track clearance (preliminary) . . . . .	12
Clutch tripbar spring (used for synchronous pulse transmission) . . . . .	9	Codelever spring . . . . .	18
Codebar bail . . . . .	11	Lockball channel . . . . .	10
Codebar bail and nonrepeat lever clearance . . . . .	11	Lockball endplay . . . . .	12
Codebar and codelever clearance . . . . .	8	Local carriage return function bail spring . . . . .	18
Codebar bail latch spring . . . . .	11	Local line feed trip link spring . . . . .	17
Codebar bail spring . . . . .	13	Plunger spring . . . . .	17
Codebar extension spring . . . . .	19	Signal Generator Mechanism	
Codebar guide clearance . . . . .	4	Clutch latchlever spring . . . . .	5
Codebar spring . . . . .	9	Clutch shoe lever . . . . .	5
Codelever universal bail spring . . . . .	4	Clutch shoe lever spring . . . . .	6
Function bail levers and codelever clearance . . . . .	10	Clutch shoe spring . . . . .	6
Lockbar spring . . . . .	9	Clutch stop lever . . . . .	5
Nonrepeat lever spring . . . . .	11	Clutch stop lever spring . . . . .	5
Spacebar bail pivot . . . . .	4	Signal contact clearance . . . . .	7
Universal bail extension . . . . .	13	Signal contact clearance (strobing) . . . . .	15
Universal bail latchlever . . . . .	13	Signal contact clearance - polar operation (strobing) . . . . .	16
Universal bail latch spring . . . . .	13	Signal contact drive link . . . . .	7
Universal codebar . . . . .	9	Signal contact spring . . . . .	7
Interrelated Features		Transfer bail detent latch spring . . . . .	7
Cam follower spring . . . . .	25	Transfer bail detent plate . . . . .	7
Clutch tripbar link return spring . . . . .	23	Transfer lever locking bail spring . . . . .	19
Codebar bail . . . . .	21	Transfer lever spring . . . . .	19
Codebar extension and punch slide latch . . . . .	22	3. VARIABLE FEATURES	
Codebar extension bail spring . . . . .	24	Answer-Back Mechanism	
Codebar extension blocking assembly . . . . .	24	Armature latch spring . . . . .	54
Detent lever spring . . . . .	24	Blocking lever spring . . . . .	54
Follower lever spring . . . . .	21	Character generator mounting plate . . . . .	50
Intermediate gear bracket . . . . .	27	Coding the message drum . . . . .	55
Keyboard control switch . . . . .	25	Detent lever spring . . . . .	50
Margin indicator spring . . . . .	19	Drive link . . . . .	51
Mounting typing unit on keyboard . . . . .	28	Drive link spring . . . . .	51
Perforator alignment . . . . .	20	Latch operating lever adjusting screw . . . . .	53
Perforator clutch release trip . . . . .	23	Latch operating lever spring . . . . .	53
Punch slide latch spring . . . . .	22	Magnet yoke . . . . .	48
Reset lever spring . . . . .	25	Motor control relay switch . . . . .	54
Signal generator frame . . . . .	28	Sensing lever springs . . . . .	50

CONTENTS	PAGE
Stepping pawl . . . . .	52
Stepping pawl spring . . . . .	53
Stop lever latch . . . . .	49
Answer-Back Mechanism ("Figs D")	
Keyboard lockball eccentric . . . . .	56
Auxiliary Contacts	
Auxiliary contacts . . . . .	58
Character Counter Mechanism	
Antibounce spring . . . . .	32
Character counter scale . . . . .	32
Character counter stroke . . . . .	34
Cord assembly . . . . .	31
End-of-line switch . . . . .	33
Ratchet drum assembly return spring.	33
Reset latchlever and drive lever spring . . . . .	34
Reset lever extension spring . . . . .	34
Stop lever . . . . .	32
Clutch Trip Delay Mechanism	
Clutch trip delay . . . . .	57
Trip delay torsion spring . . . . .	57
Code Reading Contacts (Transmitting)	
Code reading contacts (transmitting) .	60
Electrical Line Break Mechanism	
Line break lever spring . . . . .	29
Keyboard Lockbar Switch Mechanism	
Keyboard lockbar switch . . . . .	30
Keyboard lockbar switch spring . . . . .	30
Letters and Figures Contact	
Letters and figures contact . . . . .	59
Local Paper Feed-Out Mechanism	
Switch lever spring . . . . .	29
Perforator Motor	
Perforator motor pinion and driven gear mesh . . . . .	46
Power Backspace Switch	
Power backspace switch position. . . . .	43
Remote Control Gear Shift Mechanism	
Armature stop . . . . .	45
Clutch stop lever . . . . .	45
Gear shift magnet . . . . .	45

CONTENTS	PAGE
Gear shift magnet armature spring . .	44
Gear shift mechanism . . . . .	44
Repeat on Space Mechanism	
Spacebar . . . . .	35
Space repeat lever spring . . . . .	35
Stop . . . . .	35
Travel screw . . . . .	35
Synchronous Pulse Mechanism	
Armature clamp . . . . .	42
Armature hinge . . . . .	40
Contact gap . . . . .	41
Magnet armature . . . . .	40
Mounting bracket . . . . .	40
Universal codebar contact . . . . .	41
Tape-Out Switch Mechanism	
Low tape switch . . . . .	30
Switch lever spring . . . . .	30
Tape-out lever spring . . . . .	30
Time Delay Mechanism	
Contact latch pawl spring . . . . .	37
Contact pawl spring . . . . .	37
Eccentric follower pawl spring . . . . .	39
Time delay mechanism position . . . . .	38
Time delay ratchet wheel tension . . . . .	36
Time delay switch position . . . . .	36
Time delay disabling device . . . . .	39
Universal Keyboard Switch	
Keyboard universal switch . . . . .	47
Keyboard universal switch - horizontal . . . . .	47
Keyboard universal switch - vertical . . . . .	47

## 1. GENERAL

1.01 This section has been revised to include recent engineering changes and additions, and to rearrange the text, so as to bring the section generally up-to-date. Since this is an extensive revision, marginal arrows ordinarily used to indicate changes have been omitted.

1.02 This section contains the specific requirements and adjustments for the 28 perforator-transmitter base.

1.03 Maintenance procedures which apply only to mechanisms of a particular design, or to certain models of 28 perforator-transmitter bases are so indicated in the titles of the paragraphs which contain these particular adjustment requirements.

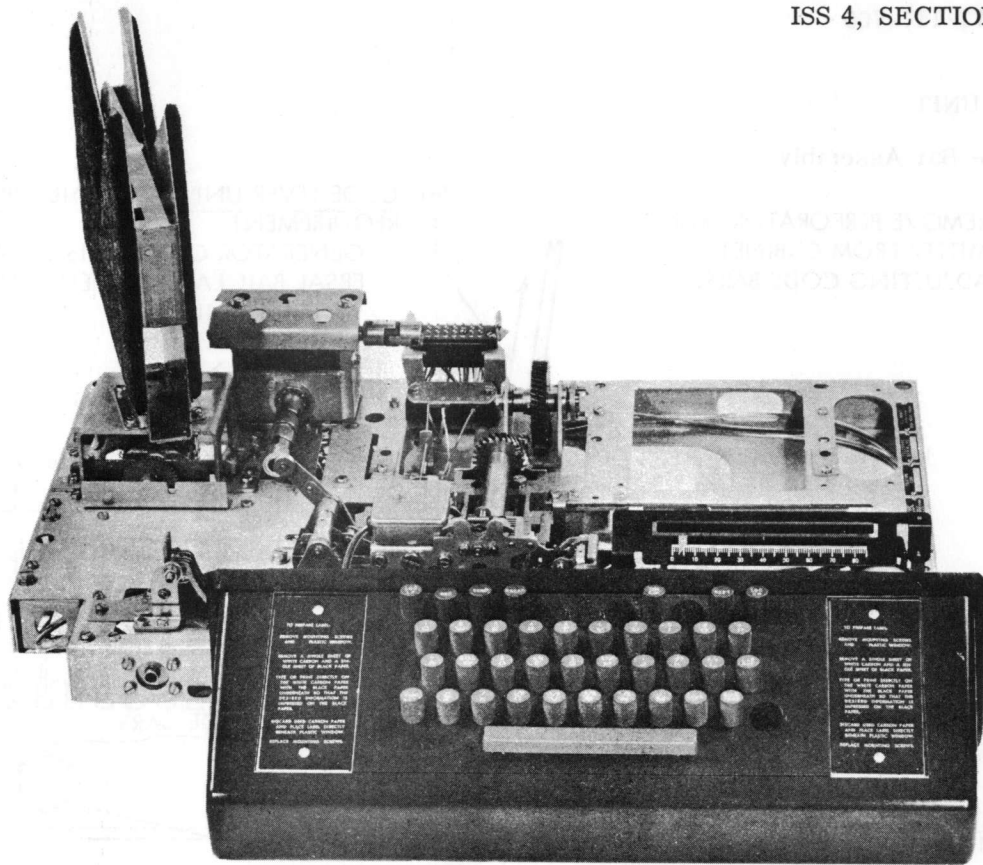

Figure 1 - 28 Perforator-Transmitter Base

1.04 The adjustments of each unit are arranged in a sequence that should be followed if a complete readjustment of the unit were undertaken. The tools and spring scales required to perform these adjustments are listed in the applicable section. After an adjustment is completed, be sure to tighten any nuts or screws that are loosened. The adjusting illustrations indicate tolerances, positions of moving parts, spring tensions and the angles at which scales should be applied when measuring spring tensions. If a part mounted on shims is removed, the number of shims used at each of its mounting screws should be noted so that the same number is replaced when the part is re-mounted.

1.05 References made to left or right, up or down, front or rear, etc apply to the unit in its normal operating position as viewed from the front.

1.06 The letters K (Keyboard), K-T (Keyboard - Tape), and T (Tape) are used in this section to refer to corresponding positions of the keyboard-control knob. Unless otherwise specified adjustments should be made in the K-T position.

1.07 When a requirement calls for a clutch to be disengaged, the clutch shoe lever must be fully latched between its trip lever and latch-lever so that the clutch shoes release their tension on the clutch drum. When engaged, the clutch shoe lever is unlatched and the clutch shoes are wedged firmly against the clutch drum.

Note: When the signal generator shaft is rotated by hand, the clutch does not fully disengage upon reaching its stop position. In order to relieve drag and permit the main shaft to rotate freely, apply pressure on the lug of the clutch disc with a screwdriver to cause it to engage its latch-lever and fully disengage the clutch.

1.08 All electrical contact points should meet squarely. Contacts with the same diameter should not be out of alignment more than 25 per cent of the contact diameter. Check contacts for pitting and corrosion and clean or bur-nish them before making specified adjustment or tolerance measurement. Avoid sharp kinks or bends in the contact springs.

**CAUTION: KEEP ALL ELECTRICAL CONTACTS FREE OF OIL AND GREASE.**

2. BASIC UNIT

2.01 Code Bar Assembly

NOTE: REMOVE PERFORATOR TRANSMITTER FROM CABINET BEFORE ADJUSTING CODE BARS.

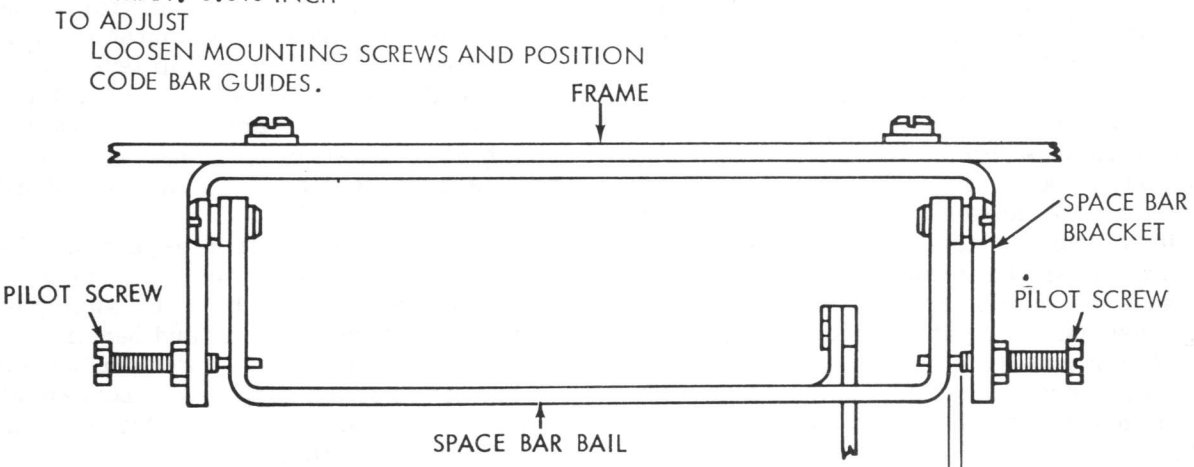
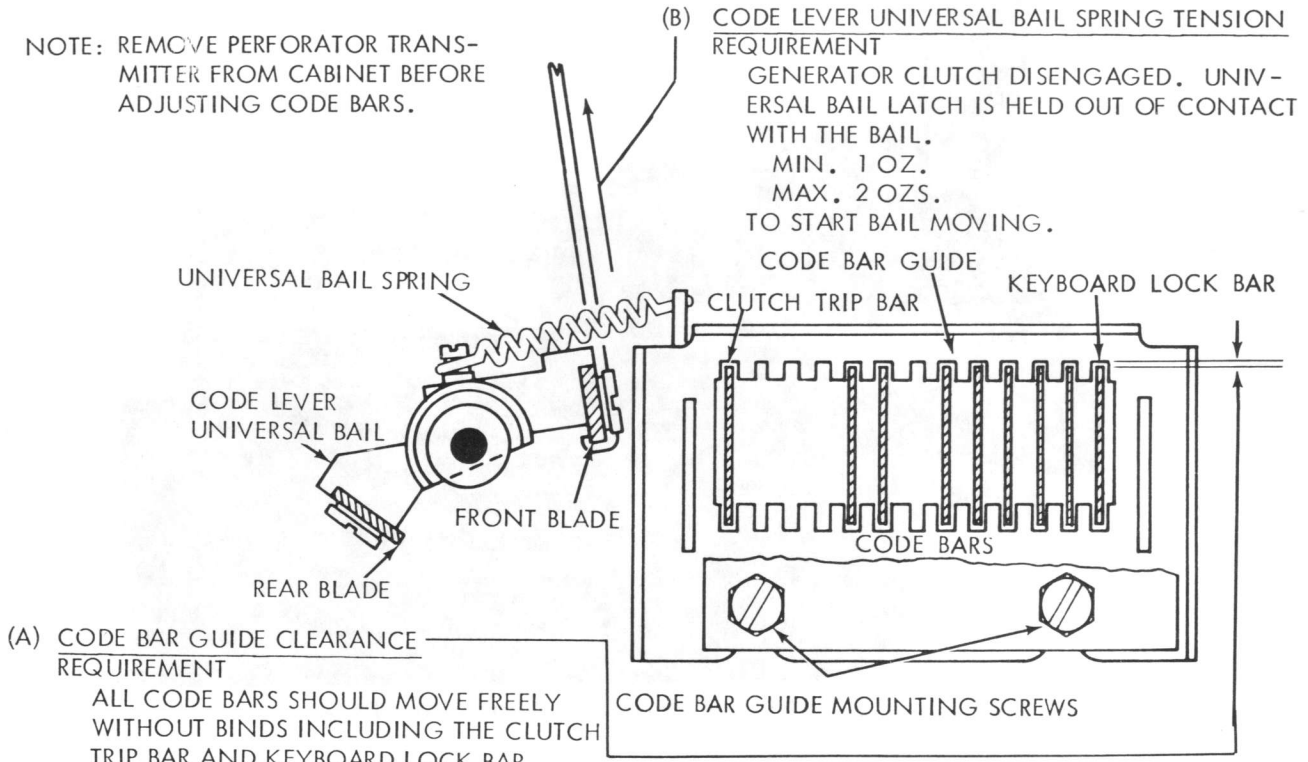

NOTE: KEYLEVER COVER MUST BE REMOVED. SEE DISASSEMBLY AND REASSEMBLY.

(C) SPACE BAR BAIL PIVOT REQUIREMENT  
 MIN. SOME END PLAY.  
 MAX. 0.010 INCH.  
 SPACE BAR FREE FROM BIND.  
 TO ADJUST  
 POSITION SPACE BAR WITH PILOT SCREWS LOOSENED.

NOTE: THE BAIL SHOULD BE SO ADJUSTED THAT THE SPACE BAR CAN BE OPERATED WITHOUT BINDING IN THE HOLES IN THE GUIDE PLATE AND THE FRAME.



2.02 Signal Generator Mechanism

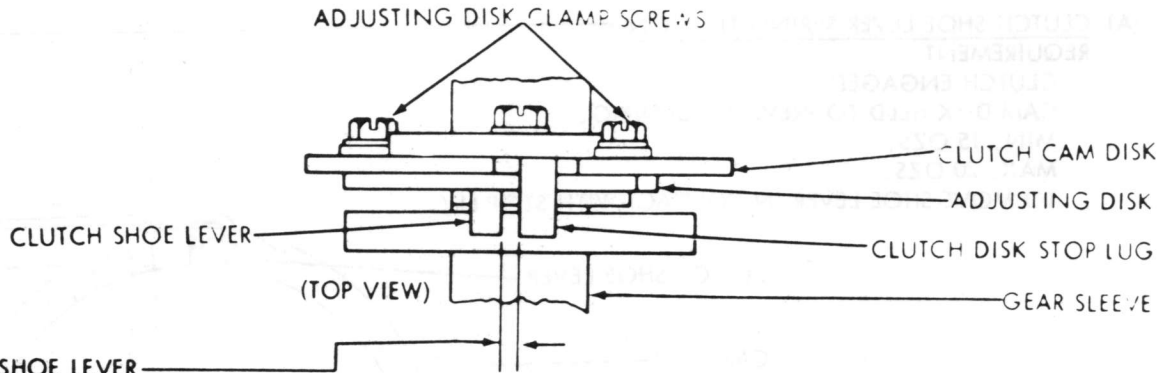

(A)

CLUTCH SHOE LEVER REQUIREMENT

CLEARANCE WHEN CLUTCH IS DISENGAGED SHOULD BE 0.055 INCH TO 0.085 INCH LESS THAN WHEN CLUTCH IS ENGAGED.

TO CHECK

LATCH CLUTCH IN DISENGAGED POSITION AND MEASURE CLEARANCE. ROTATE GEAR UNTIL OIL HOLE IS UPWARD. ENGAGE CLUTCH AND MEASURE CLEARANCE.

TO ADJUST

LOOSEN THE TWO ADJUSTING DISK CLAMP SCREWS TO POSITION DISK.

(C)

CLUTCH STOP LEVER SPRING TENSION REQUIREMENT

CLUTCH ENGAGED AND ROTATED 1/4 TURN.

MIN. 2 OZS.

MAX. 3 OZS.

TO START LEVER MOVING.

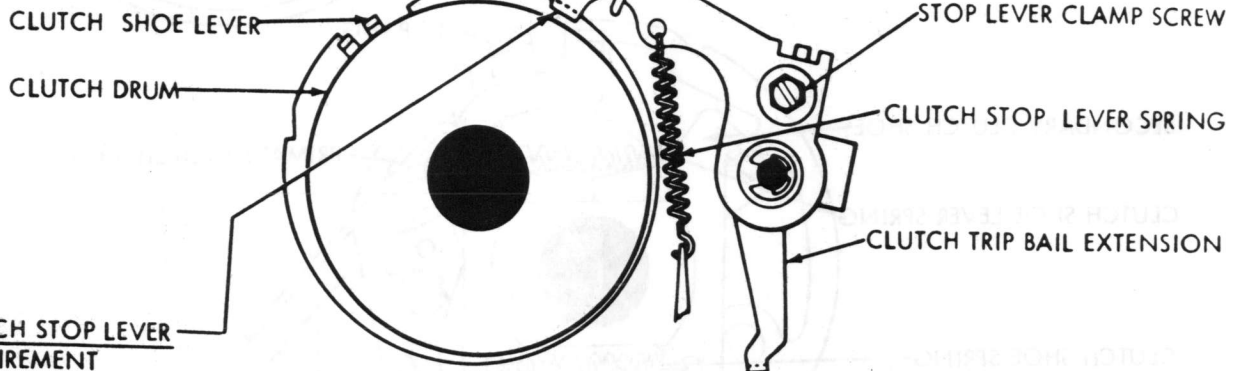

(B)

CLUTCH STOP LEVER REQUIREMENT

SHOULD FULLY ENGAGED CLUTCH SHOE LEVER.

DURING ROTATION, THE LEVER SHOULD NOT TOUCH THE CLUTCH DRUM AT ANY POINT.

TO ADJUST

POSITION STOP LEVER WITH ITS CLAMP SCREW LOOSENED.

(D) CLUTCH LATCH LEVER SPRING TENSION REQUIREMENT

CLUTCH LATCH LEVER RESTING ON THE HIGHEST POINT OF CLUTCH DISK.

MIN. 2 OZS.

MAX. 3 OZS.

TO START LATCH LEVER MOVING.

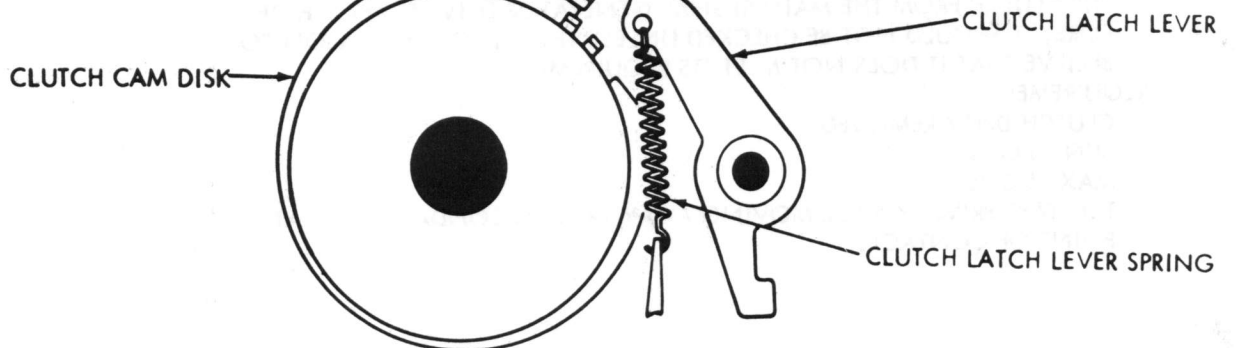

2.03 Signal Generator Mechanism continued

(A) CLUTCH SHOE LEVER SPRING TENSION  
REQUIREMENT

CLUTCH ENGAGED.  
CAM DISK HELD TO PREVENT TURNING.  
MIN. 15 OZS.  
MAX. 20 OZS.  
TO MOVE SHOE LEVER IN CONTACT WITH STOP LUG.

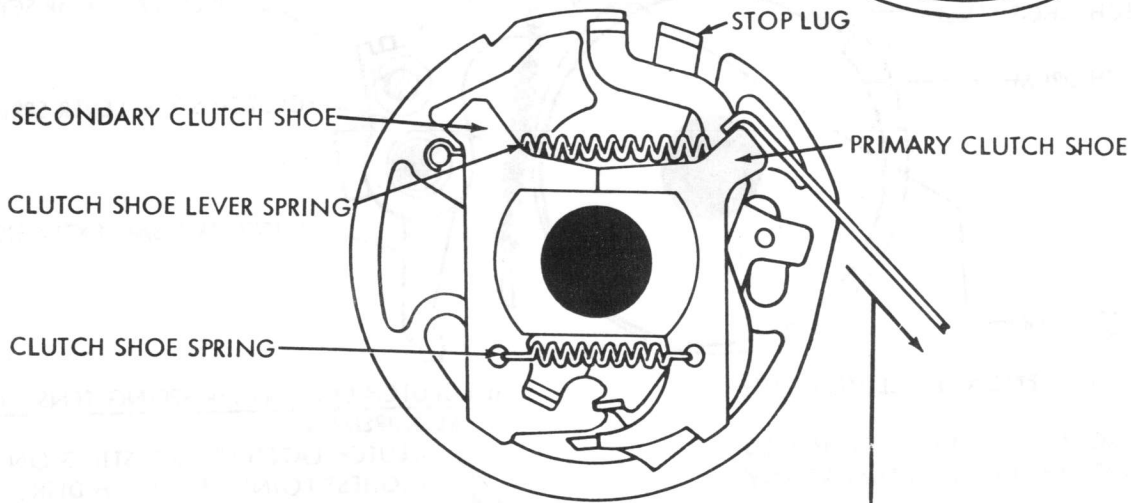
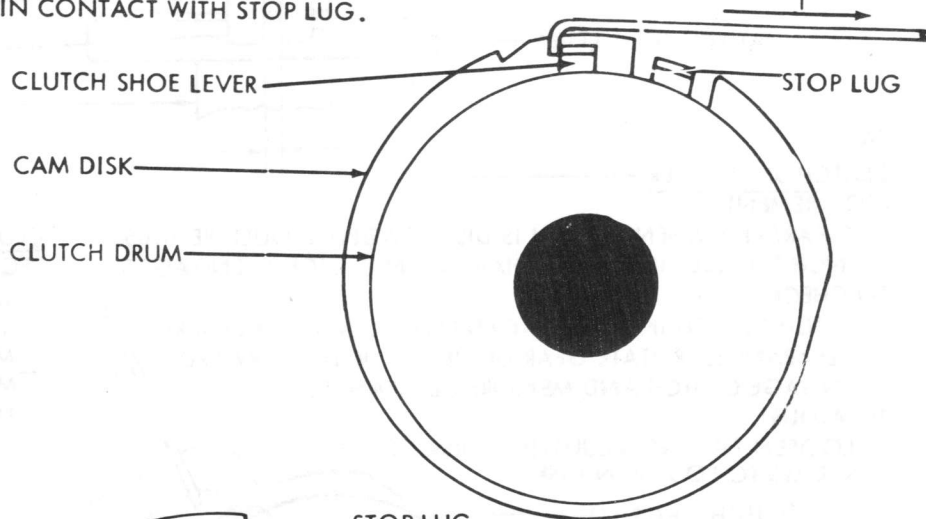

(B) CLUTCH SHOE SPRING TENSION  
NOTE

IN ORDER TO CHECK THIS SPRING TENSION, IT IS NECESSARY TO REMOVE THE CLUTCH FROM THE MAIN SIGNAL GENERATOR DRIVE SHAFT. THEREFORE, IT SHOULD NOT BE CHECKED UNLESS THERE IS GOOD REASON TO BELIEVE THAT IT DOES NOT MEET ITS REQUIREMENT.

REQUIREMENT

CLUTCH DRUM REMOVED.  
MIN. 3 OZS.  
MAX. 5 OZS.  
TO START PRIMARY SHOE MOVING AWAY FROM SECONDARY SHOE AT POINT OF CONTACT.

2.04 Signal Generator Mechanism continued

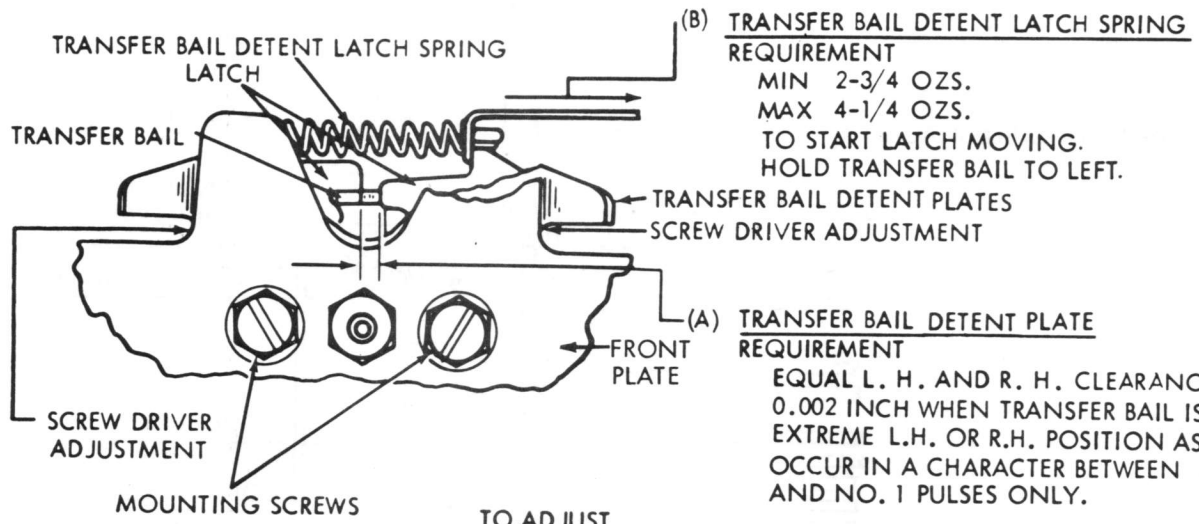

TO ADJUST  
 ROTATE DETENT PLATE RIGHT OR LEFT BY MEANS OF SCREWDRIVER WITH DETENT PLATE MOUNTING SCREWS LOOSENED.

(C) SIGNAL CONTACT CLEARANCE REQUIREMENT  
 MARKING AND SPACING GAPS SHOULD BE EQUAL WITHIN 0.001 INCH.  
 TO CHECK  
 DEPRESS Y KEYLEVER AND ROTATE SIGNAL GENERATOR CAM SLEEVE UNTIL EACH CONTACT HAS FULLY OPENED.  
 TO ADJUST  
 LOOSEN MOUNTING SCREWS AND MOVE CONTACT BOX BY MEANS OF ECCENTRIC.

NOTE: CHECK BY MEANS OF SIGNAL CHECKING DEVICE WHERE POSSIBLE, AND CAREFULLY RE-FINE THE ADJUSTMENT TO ELIMINATE ALL BIAS FROM THE SIGNALS BY EQUALIZING THE CURRENT-ON AND CURRENT-OFF INTERVALS

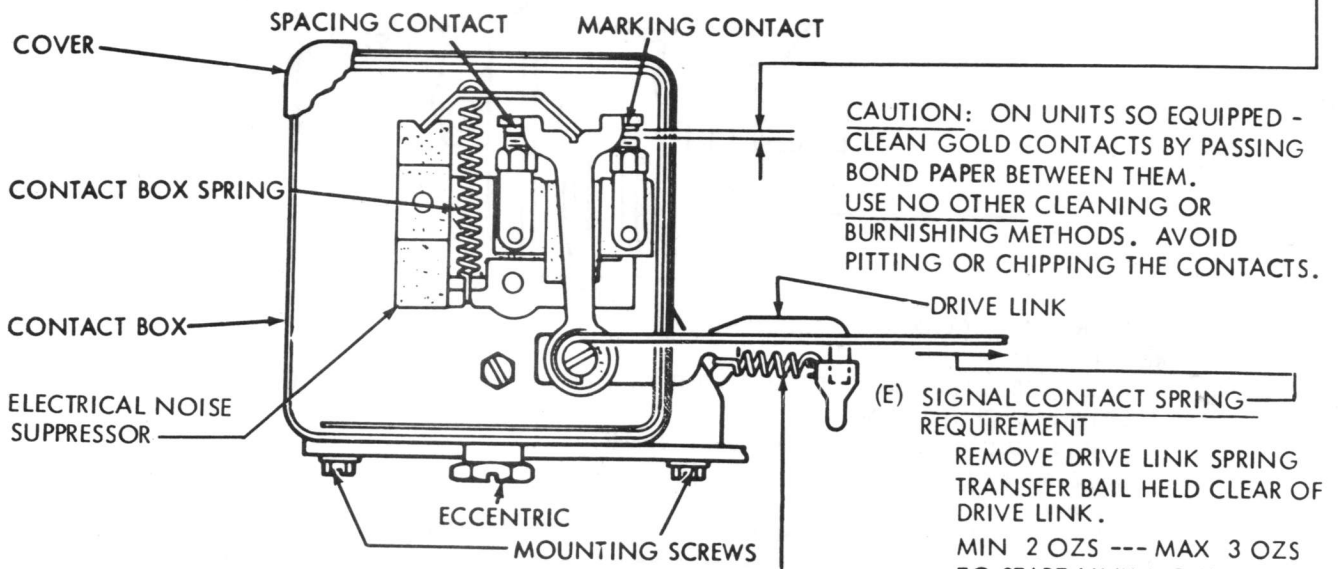

(D) SIGNAL CONTACT DRIVE LINK REQUIREMENT  
 WITH MAINSHAFT IN STOP POSITION AND TRANSFER BAIL DETENT LATCH SPRING UNHOOKED (SEE FIG ABOVE), MOVE LATCHES AWAY FROM TRANSFER BAIL EXTENSION. HOLD THE TOGGLE FIRMLY AGAINST CONTACTS.  
 MIN 6 OZS --- MAX 9 OZS  
 TO START TRANSFER BAIL EXTENSION MOVING.

2.05 Codebar Assembly continued

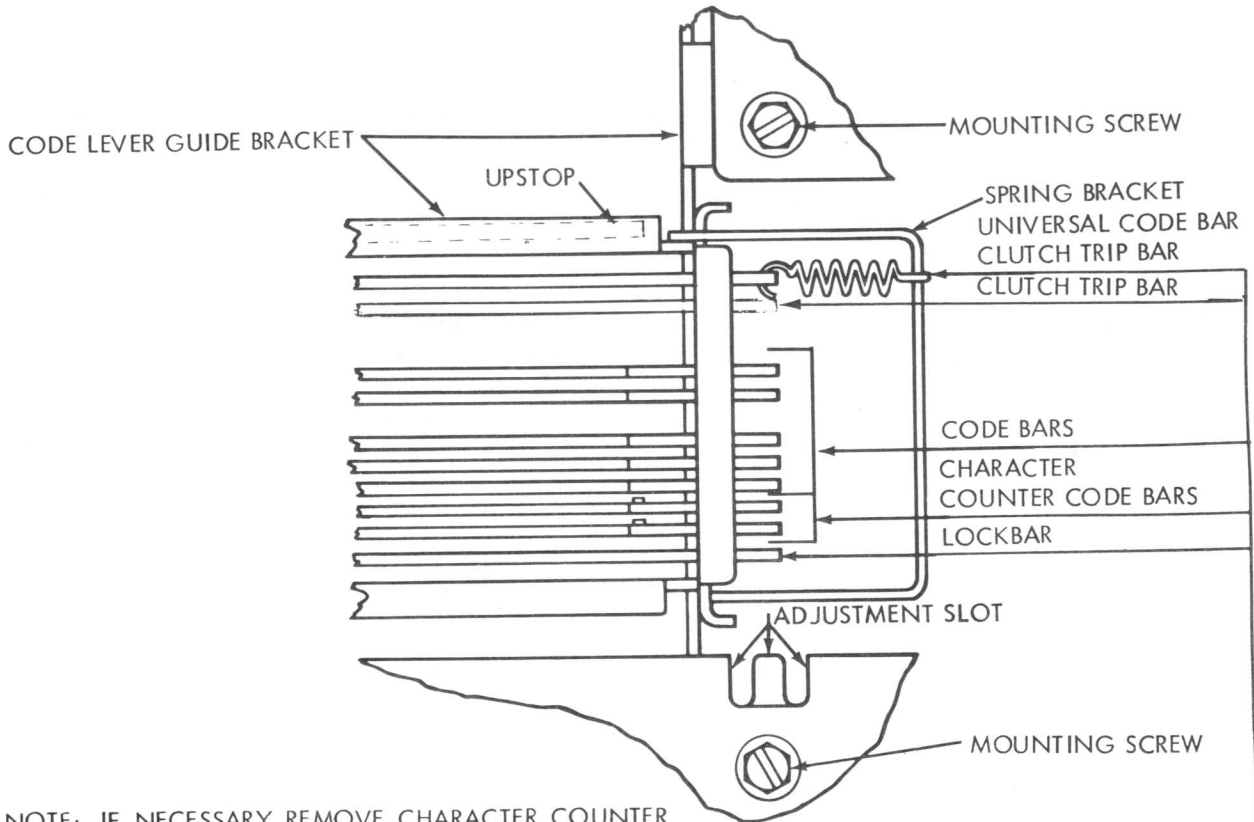

NOTE: IF NECESSARY REMOVE CHARACTER COUNTER ASSEMBLY. SEE DISASSEMBLY AND REASSEMBLY.

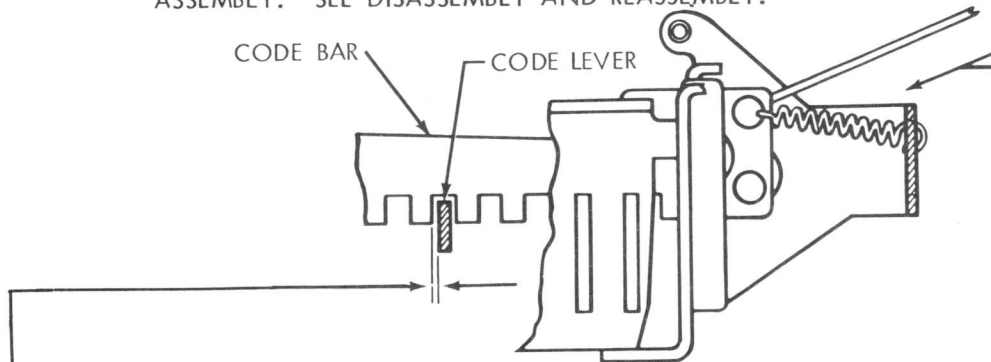

(A) CODE BAR AND CODE LEVER CLEARANCE  
REQUIREMENT

CARRIAGE RETURN KEY DEPRESSED BUT NOT ENOUGH TO TRIP OFF UNIVERSAL BAIL LATCH OR CLUTCH BAR.

MIN. 0.006 INCH --- MAX. 0.017 INCH  
MEASURE AT CODE BAR #3

TO ADJUST

POSITION GUIDE BY ADJUSTING SLOT WITH FOUR MOUNTING SCREWS LOOSENED.

(B) CLUTCH TRIP BAR SPRING TENSION  
REQUIREMENT

BLANK KEY DEPRESSED TO ALLOW THE CLUTCH TRIP BAR TO FALL TO RIGHT.

SPRING UNHOOKED FROM BRACKET

MIN. 8 OZS. --- MAX. 12 OZS.

TO PULL SPRING TO INSTALLED LENGTH.

NOTE: SEE FOLLOWING PAGE FOR ADJUSTMENTS (C), (D), (E) AND (F).

## Codebar Assembly continued

NOTE: ADJUSTMENTS CONTINUED FROM  
PRECEDING PAGE.

(C) CLUTCH TRIP BAR (USED FOR SYNCHRONOUS PULSED TRANSMISSION)REQUIREMENT

WITH THE CLUTCH DISENGAGED AND LATCHED, POWER OFF AND ARMATURE OF THE MAGNET ASSEMBLY HELD AWAY FROM THE CLUTCH TRIP BAR. PUSH AT THE RIGHT HAND END OF CLUTCH TRIP BAR.

MIN. 9 OZS. --- MAX. 12 OZS.  
TO START CLUTCH TRIP BAR MOVING.

NOTE: HOLD THE SWINGER OF THE CONTACT ASSEMBLY AWAY FROM THE UNIVERSAL CODE BAR WHEN MEASURING THE CLUTCH TRIP SPRING TENSION.

(D) UNIVERSAL CODE BAR (USED FOR SYNCHRONOUS PULSED TRANSMISSION)REQUIREMENT

WITH THE CLUTCH DISENGAGED AND LATCHED, DEPRESS THE BLANK KEY TO ALLOW THE UNIVERSAL CODE BAR TO FALL TO THE RIGHT. SPRING UNHOOKED FROM THE BRACKET.

MIN. 8 OZS. --- MAX. 12 OZS.  
TO PULL SPRING TO INSTALLED LENGTH.

(E) CODE BAR SPRING TENSIONREQUIREMENT

KEYBOARD IN K POSITION, LETTERS KEYLEVER DEPRESSED (POWER OFF) HOLD TRANSFER LEVERS (REF. FIGURE 1-15) TO THE RIGHT SO THEY DO NOT AFFECT THE CODE BARS.

MIN. 3 OZS. --- MAX. 5 OZS.  
TO START CODE BAR MOVING.

(F) LOCK BAR SPRING TENSIONREQUIREMENT

CLUTCH DISENGAGED, KEYBOARD LOCK KEYLEVER DEPRESSED. APPLY PUSH END OF SCALE AGAINST R.H. END OF LOCK BAR.

MIN. 2-1/2 OZS. --- MAX. 6 OZS.  
TO START LOCK BAR MOVING.



2.06 Codebar Assembly continued

(A) FUNCTION BAIL AND CODE LEVER CLEARANCE REQUIREMENT

MIN. 0.015 INCH  
BETWEEN ANY FUNCTION BAIL AND ITS  
ADJACENT CODE LEVER.

TO ADJUST  
POSITION FUNCTION BAIL ASSEMBLY WITH  
MOUNTING SCREWS AND TYPING UNIT  
LOCATING STUDS LOOSENED.

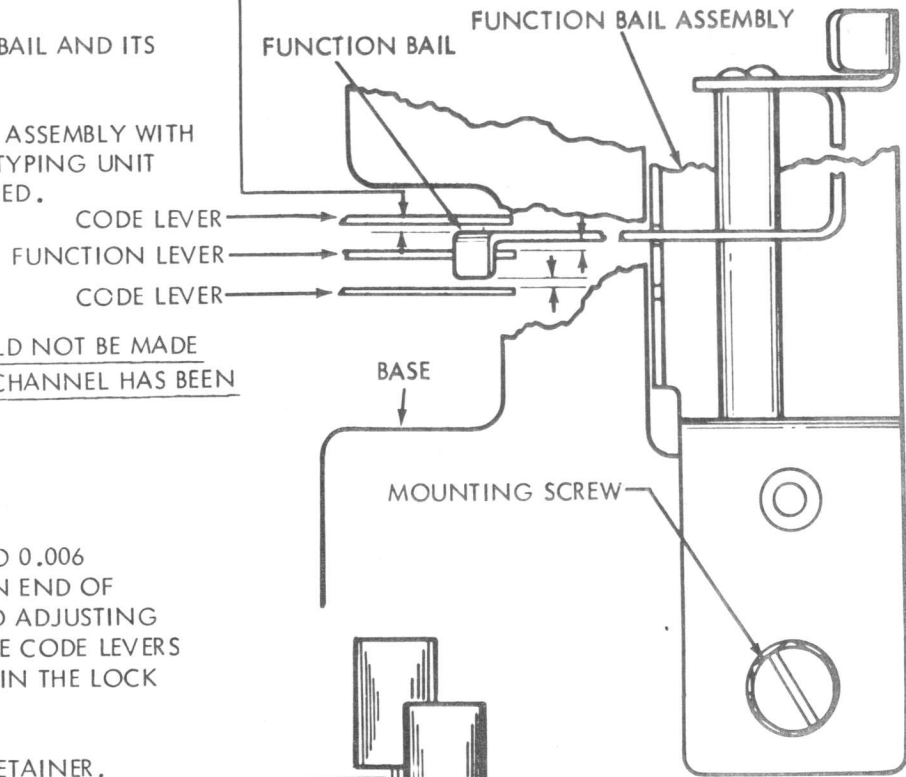

NOTE: THIS ADJUSTMENT SHOULD NOT BE MADE  
UNLESS THE LOCK BALL CHANNEL HAS BEEN  
DISASSEMBLED.

2.07 Keyboard Mechanism

(B) LOCK BALL CHANNEL REQUIREMENT

THERE SHOULD BE SOME TO 0.006  
INCH CLEARANCE BETWEEN END OF  
LOCK BALL CHANNEL AND ADJUSTING  
SCREW WHEN MOST OF THE CODE LEVERS  
ARE CENTRALLY LOCATED IN THE LOCK  
BALL CHANNEL SLOTS.

TO CHECK  
REMOVE THE LOCK BALL RETAINER.  
REMOVE A WEDGE FROM EACH END AND  
ONE FROM THE CENTER IN ORDER TO  
VIEW THE POSITION OF THE CODE LEVER.

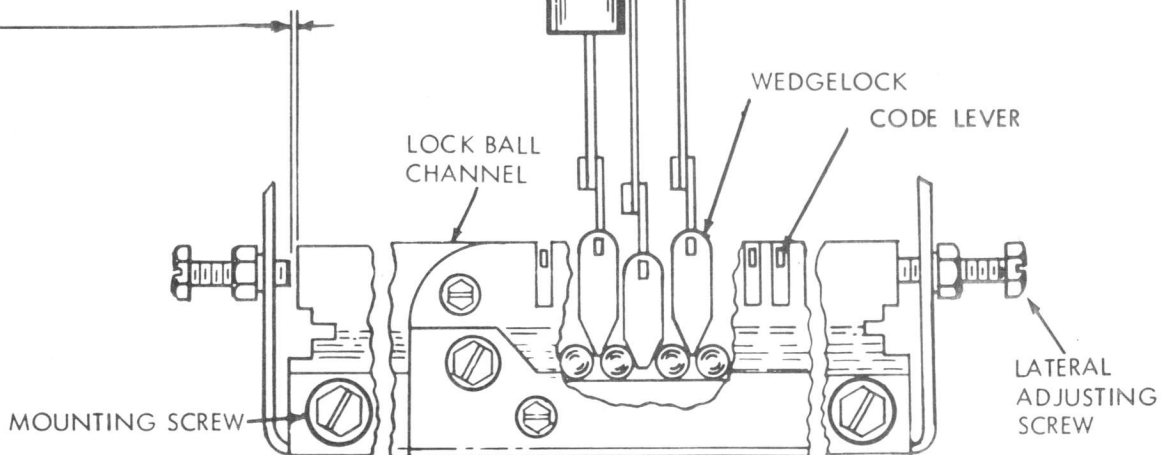

TO ADJUST

LOOSEN THE LOCK BALL CHANNEL MOUNTING SCREWS. BACK OFF LATERAL ADJUSTING SCREWS AND POSITION CHANNEL. TURN ONE ADJUSTING SCREW IN AGAINST THE END OF THE CHANNEL AND LOCK IT. TURN THE OTHER ADJUSTING SCREW IN TO THE END OF THE CHANNEL AND BACK IT OFF 1/4 TURN. LOCK THE SCREW. REPLACE THE WEDGES AND CHECK THEIR POSITION WITH RESPECT TO THE BALLS. PULL CHANNEL ASSEMBLY DOWNWARD UNTIL ALL CODE LEVERS STRIKE THEIR UPSTOP WITHOUT WEDGES JUMPING OUT OF POSITION. REPLACE LOCK BALL RETAINER. BACK OFF BALL ENDPLAY ADJUSTING SCREW.

2.08 Code Bar Assembly continued

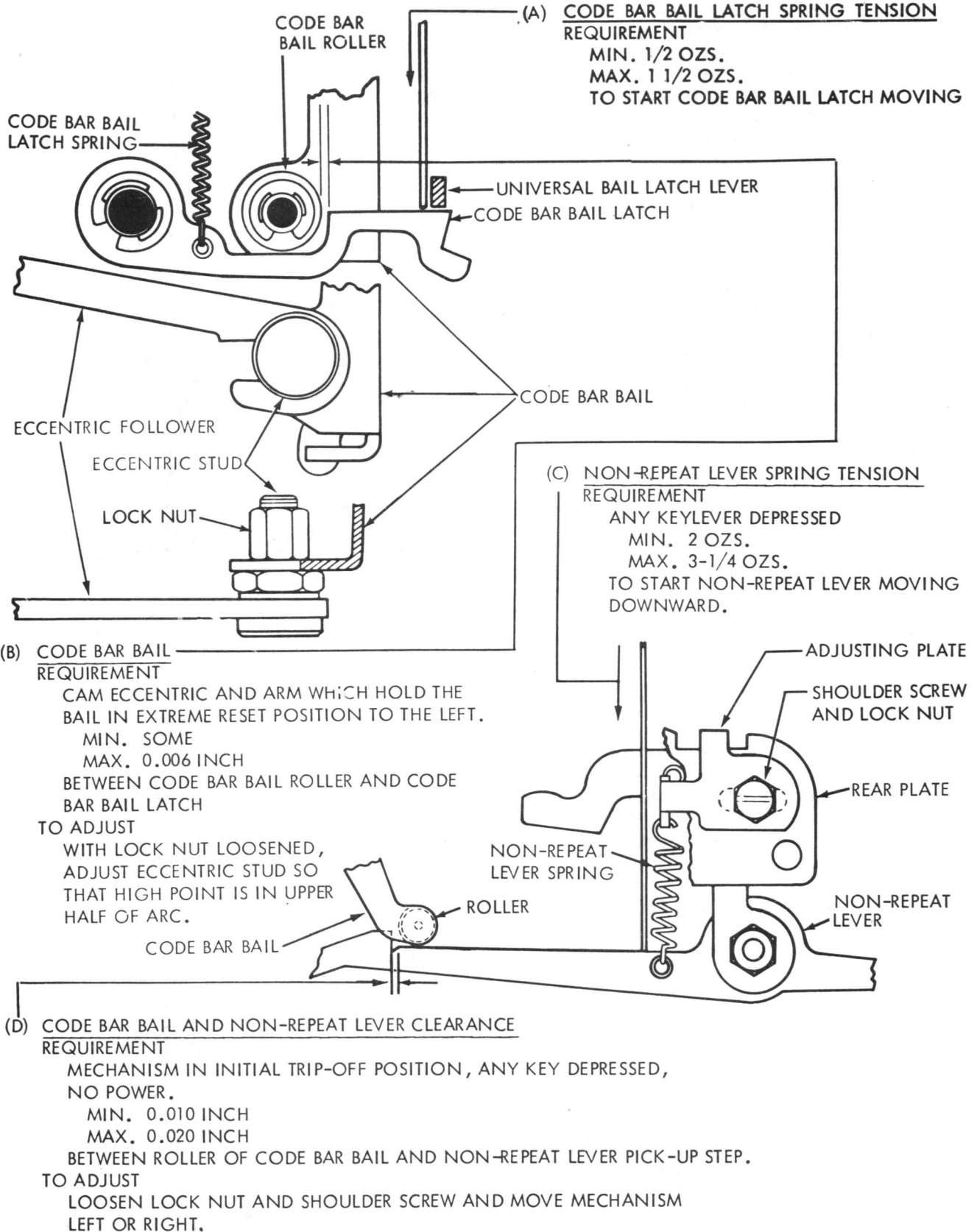

2.09 Keyboard Mechanism continued

(A) BALL WEDGELOCK AND BALL TRACK CLEARANCE  
 REQUIREMENT (PRELIMINARY)

ADJUSTMENT SCREW BACKED OUT TO PERMIT MAXIMUM BALL MOVEMENT WITHOUT THE BALLS ROLLING OUT OF TRACK. (FROM PREVIOUS LATERAL ADJUSTMENT)  
 APPLY 32 OZS. OF PRESSURE TO THE "Q" OR THE "P" KEYLEVER  
 MIN. 0.005 INCH  
 MAX. 0.015 INCH  
 EQUAL WITHIN 0.005 INCH BETWEEN THE TIP OF THE WEDGE-LOCK AND THE BALL TRACK.

TO ADJUST

LOOSEN MOUNTING SCREWS AT EACH END OF THE BALL TRACK AND ADJUST TRACK UP OR DOWN.

NOTE: REMOVE KEYBOARD HOOD IN ORDER TO MAKE THIS ADJUSTMENT. SEE DISASSEMBLY AND REASSEMBLY

NOTE: WHEN GAUGING THESE CLEARANCES MAKE SURE THERE IS NO CLEARANCE BETWEEN THE LOWER EDGE OF CODE LEVER EXTENSIONS AND THE BOTTOM OF THE SLOTS IN THE WEDGES. A TOTAL OF 43 BALLS ARE REQUIRED IN THE BALL TRACK ASSEMBLY.

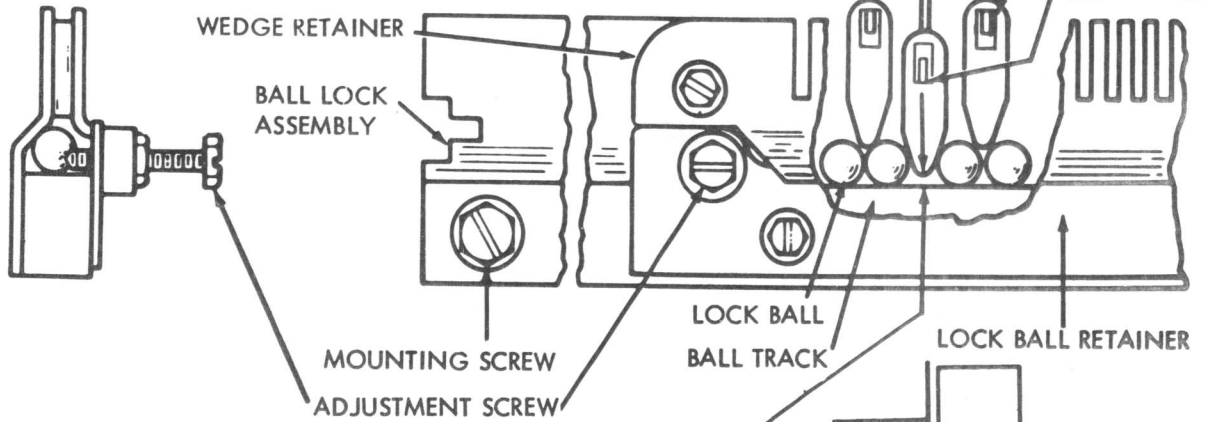

(B) LOCK BALL-END PLAY

REQUIREMENT (PRELIMINARY)

WITH A 32 OZS. PRESSURE APPLIED TO THE CAR. RET. KEY, THE BALLS SHALL HAVE A MIN. CLEARANCE

TO ADJUST

TURN IN BALL END-PLAY ADJUSTMENT SCREW WITH FINGERS UNTIL A RESISTANCE IS FELT, TIGHTEN THE NUT.

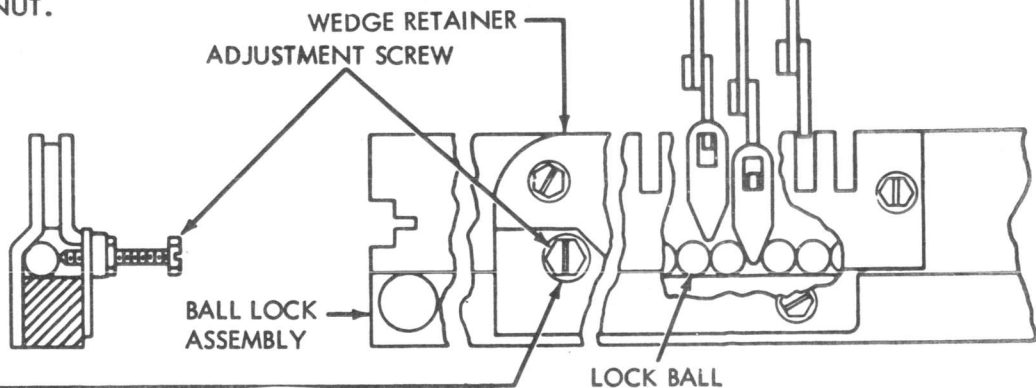

2.10 Codebar Assembly continued

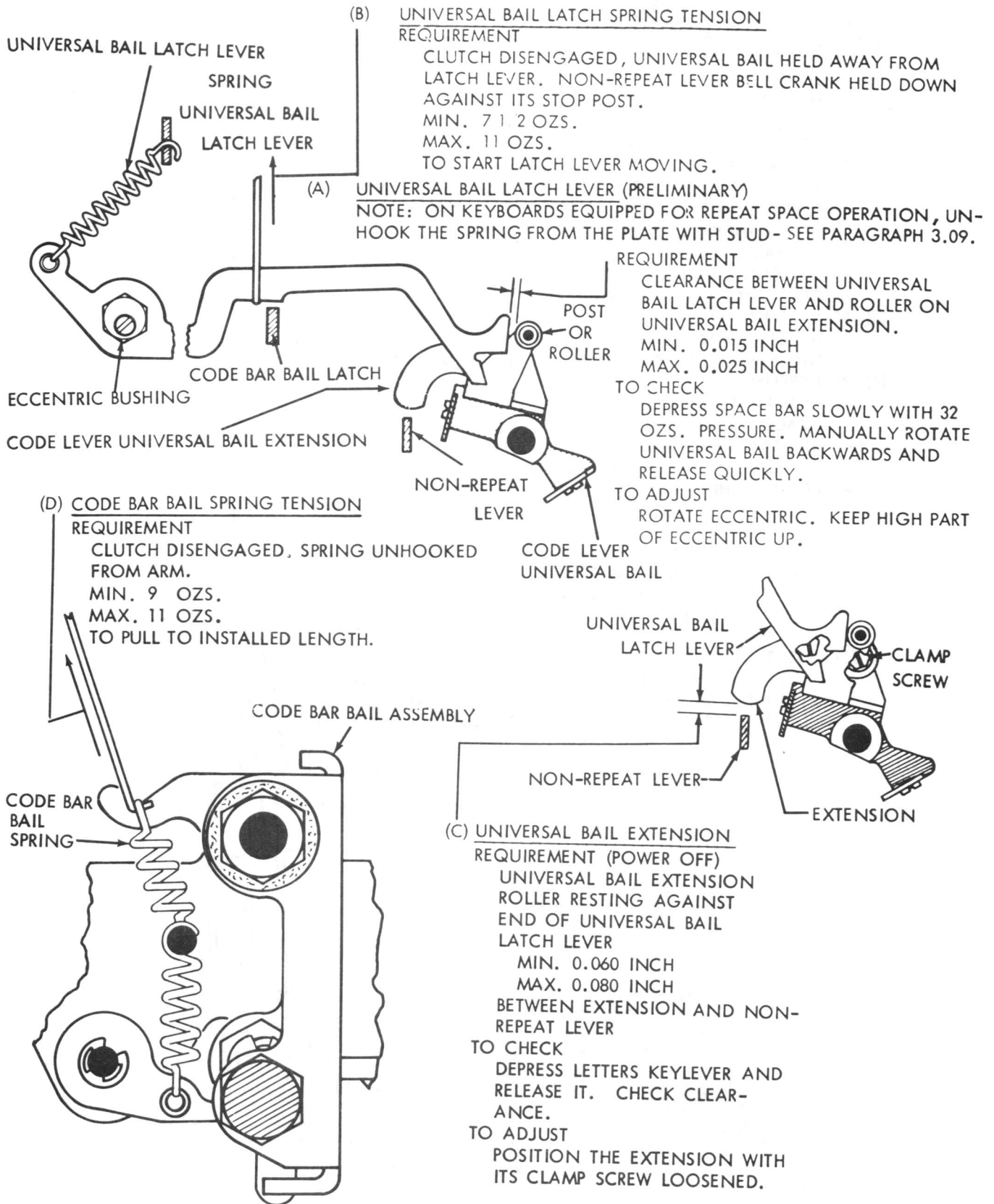

2.11 Keyboard Mechanism continued

BALL WEDGELOCK, BALL END-PLAY AND UNIVERSAL BAIL LATCH ADJUSTMENTS - (FINAL)

CHECK UNDER POWER

- (1) REQUIREMENT  
MIN. 2 OZS.  
MAX. 5 OZS.  
TO TRIP ANY CENTER ROW KEY.
- (2) REQUIREMENT  
WITH 5-1/2 OZS. PRESSURE APPLIED PERPENDICULAR TO THE "A" KEY, DEPRESS EACH KEY IN THE THIRD ROW. THE "A" KEY SHALL TRIP EACH TIME A KEY IS RELEASED. REPEAT THIS CHECK WITH THE 5-1/2 OZS. PRESSURE ON THE "CAR. RET." KEY.
- (3) REQUIREMENT  
THE CLUTCH SHALL NOT TRIP WHEN ANY TWO KEYS ARE DEPRESSED SIMULTANEOUSLY.
- (4) REQUIREMENT  
WITH  $4\text{-}1/4 \pm 1/4$  OZ. APPLIED TO THE "SPACE BAR," DEPRESS "CAR. RET." KEY. THE "SPACE BAR" SHALL TRIP EACH TIME THE "CAR. RET." KEY IS RELEASED BY MOVING THE FINGER OFF THE KEY IN A HORIZONTAL DIRECTION.

NOTE  
DISREGARD MULTIPLE SPACE OPERATION IF UNIT IS EQUIPPED WITH 163775 MODIFICATION KIT FOR REPEAT-SPACE OPERATION.

TO ADJUST  
IF NECESSARY, REFINE PRELIMINARY BALL WEDGELOCK, PRELIMINARY BALL END-PLAY, PRELIMINARY UNIVERSAL BAIL LATCH, AND UNIVERSAL BAIL EXTENSION ADJUSTMENTS.

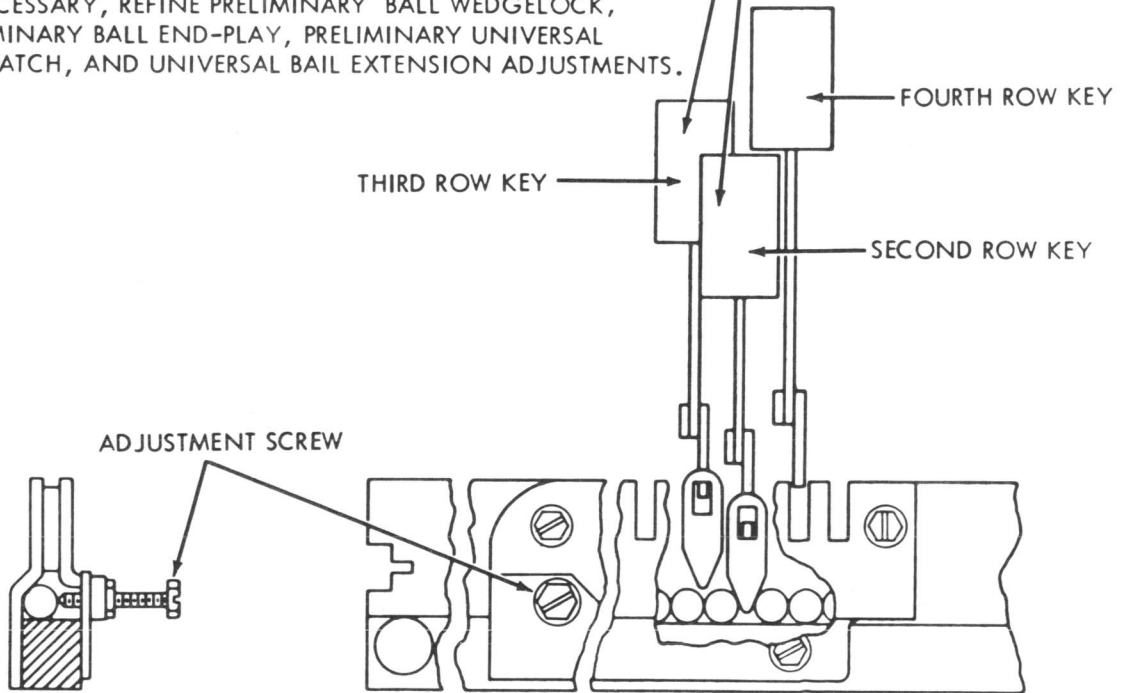



2.12 Signal Generator Mechanism continued

SIGNAL CONTACT CLEARANCE (USING SIGNAL TEST SET --- SUCH AS DXD/LSS)  
PRELIMINARY --- WITH ELECTRICAL NOISE SUPPRESSOR DISCONNECTED FROM CIRCUIT, CONNECT SIGNAL CONTACTS SO AS TO INTERRUPT (KEY) CURRENT TO "STROBE" LAMP OF DXD OR LSS. TEST SET AND KEYBOARD MUST OPERATE AT SAME SPEED. (SEE TABLE 1-1).

REQUIREMENTS

- (1) WITH BLANKS COMBINATION SELECTED, ORIENT SCALE OF TEST SET TO ALIGN ZERO MARK OF STOP SEGMENT WITH BEGINNING OF STOP PULSE IMAGE. LENGTH OF TRACE SHALL BE FROM THE ZERO MARK (NOTE 1.) TO  
 ( MIN. 141-1/2 DIVISIONS ----- MAX. 142-1/2 DIVISIONS )  
 TO ADJUST - IF VARIATIONS OCCUR, POSITION SCALE SO THAT VARIATIONS EXTEND EQUALLY ON RIGHT & LEFT OF 142 MARK.
- (2) NOMINAL LENGTH OF PULSES NO. 1, 2, 3, 4, & 5 IS 100 DIVISIONS. TO ADJUST - RECHECK CONTACT CLEARANCE REQUIREMENT FIG. 1-4. REFINE CLEARANCE, WHERE NECESSARY, TO FAVOR PULSES 1 THRU. 5 BY ORIENTING BEGINNING OF STOP PULSE TRACE UP TO  $\pm 5$  DIVS. FROM ZERO MARK OF SEGMENT (REFER TO REQUIREMENTS "A" AND "B" BELOW)
- (3) EACH PULSE TRACE (SEE "C" BELOW) TO BE FREE OF UNDERSIRABLE BREAKS. TO ADJUST - RECHECK TRANSFER BAIL DETENT PLATE REQUIREMENT. (FIG. 1-4) AND WHERE NECESSARY, REFINE ADJUSTMENT. NOTE --- DETENT PLATE MAY BE ROTATED EITHER LEFT OR RIGHT AS LONG AS DETENT TOGGLE LATCH CONTINUES TO CAM OFF PROJECTION OF TRANSFER BAIL.

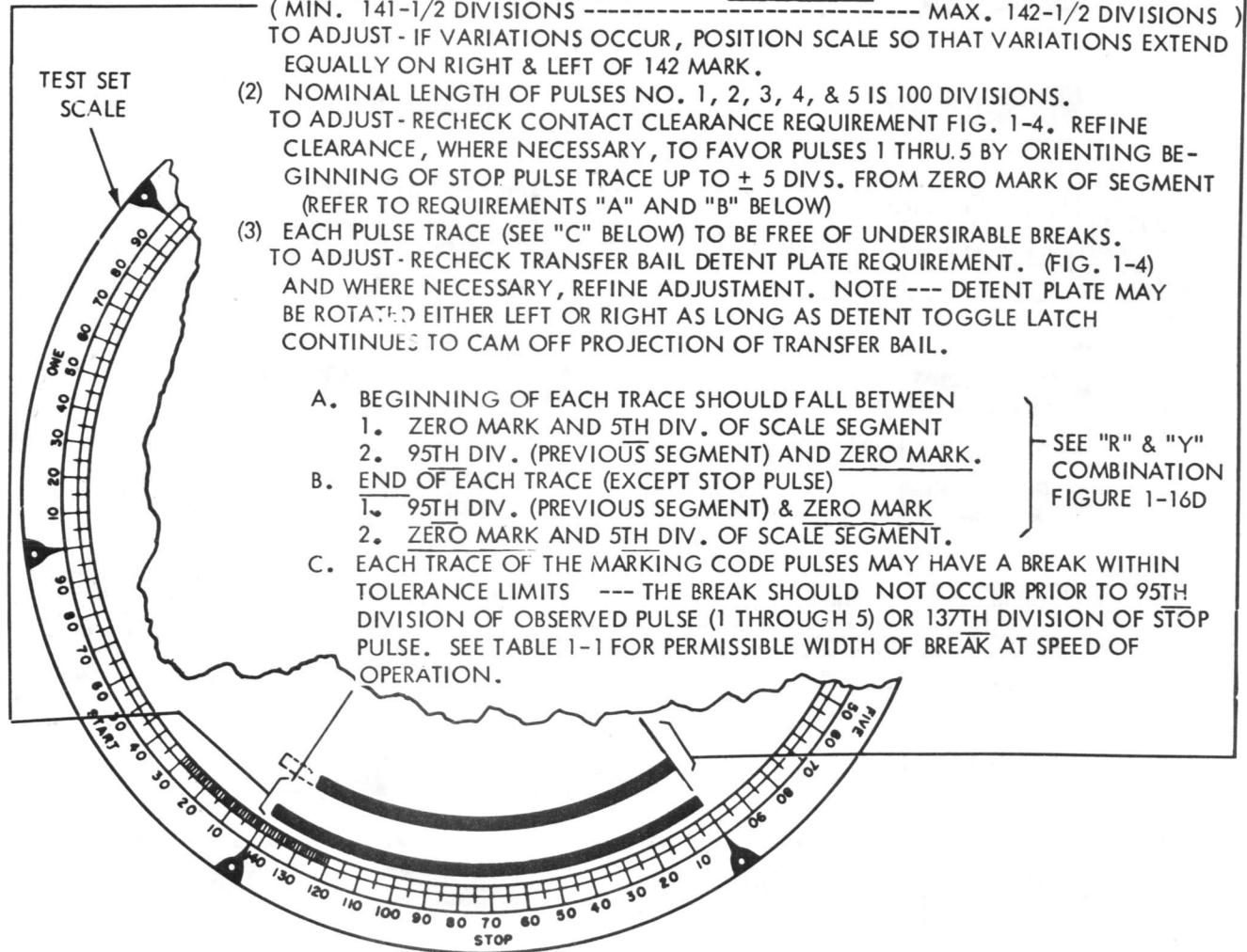

- A. BEGINNING OF EACH TRACE SHOULD FALL BETWEEN
    1. ZERO MARK AND 5TH DIV. OF SCALE SEGMENT
    2. 95TH DIV. (PREVIOUS SEGMENT) AND ZERO MARK.
  - B. END OF EACH TRACE (EXCEPT STOP PULSE)
    1. 95TH DIV. (PREVIOUS SEGMENT) & ZERO MARK
    2. ZERO MARK AND 5TH DIV. OF SCALE SEGMENT.
  - C. EACH TRACE OF THE MARKING CODE PULSES MAY HAVE A BREAK WITHIN TOLERANCE LIMITS --- THE BREAK SHOULD NOT OCCUR PRIOR TO 95TH DIVISION OF OBSERVED PULSE (1 THROUGH 5) OR 137TH DIVISION OF STOP PULSE. SEE TABLE 1-1 FOR PERMISSIBLE WIDTH OF BREAK AT SPEED OF OPERATION.
- } SEE "R" & "Y" COMBINATION FIGURE 1-16D

TABLE 1-1 SIGNALING PULSE SPEED AND PERMISSIBLE WIDTH OF BREAK

SPEED	OPERATIONS PER MINUTE	WIDTH OF BREAK NOT TO EXCEED	REMARKS
60 W.P.M.	368.182	1 DIVISION	MARKING PULSES (1 THROUGH 5 & STOP)
75 W.P.M.	460.00	1-1/2 DIVISION	MARKING PULSES (1 THROUGH 5 & STOP)
100 W.P.M.	600.00	2 DIVISION	MARKING PULSES (1 THROUGH 5 & STOP)

2.13 Signal Generator Mechanism continued

"R" AND "Y" COMBINATION

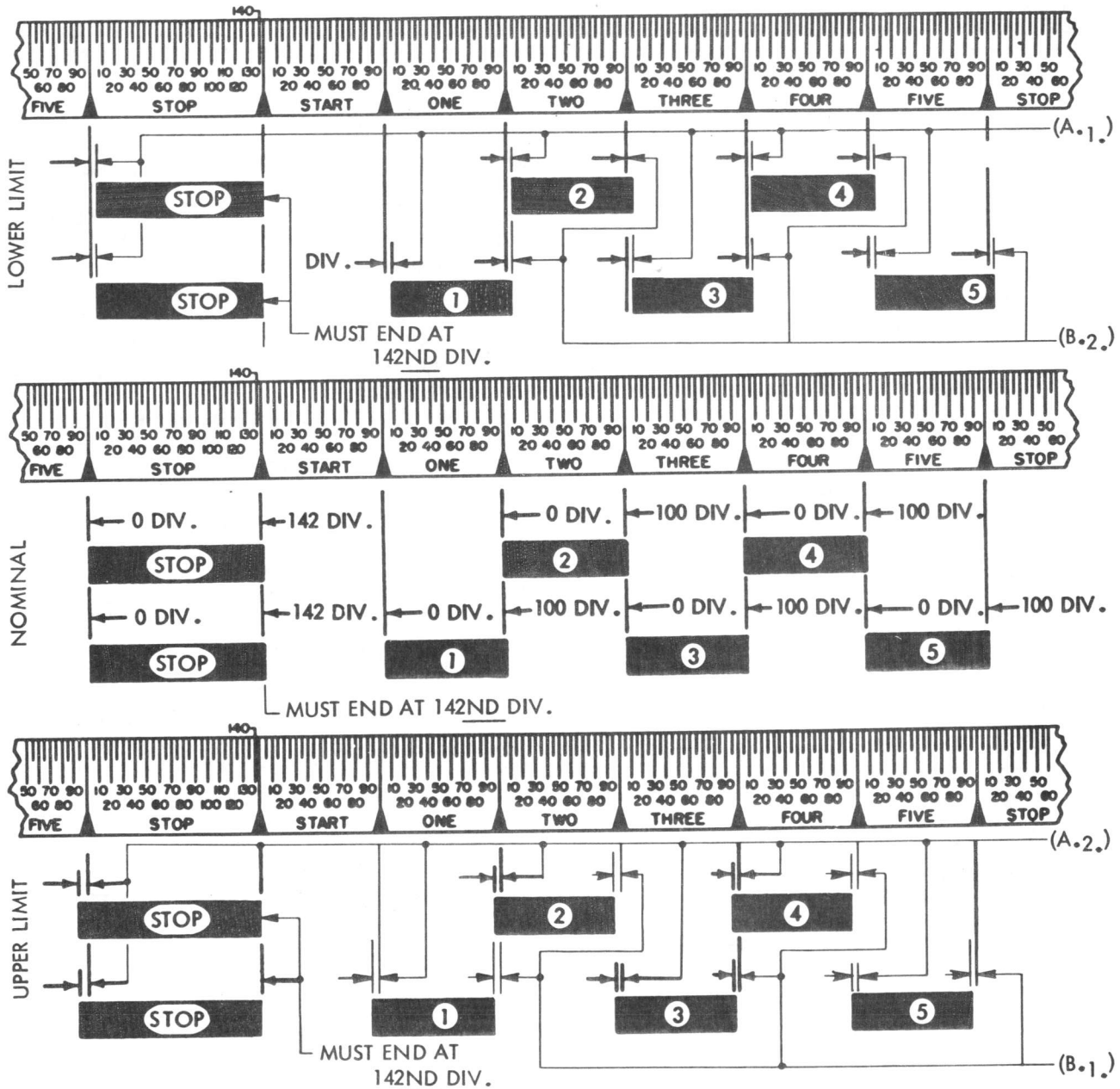

FOR UNITS WITH SPACING CONTACTS OF SIGNAL GENERATOR WIRED FOR POLAR OPERATION  
REQUIREMENTS ---

- (1) SPACING PULSES SHALL START NO EARLIER THAN 94TH DIV. OF PREVIOUS SEGMENT AND NO LATER THAN 6TH DIV. OF PULSE UNDER OBSERVATION.
- (2) TRACE OF SPACING PULSE SHALL END NO EARLIER THAN 94TH DIV. OF PULSE UNDER OBSERVATION AND END NO LATER THAN 6TH DIV. OF FOLLOWING PULSE.
- (3) TRACE OF START PULSE SHALL BEGIN NO EARLIER THAN 136TH DIV. OF STOP SEGMENT AND NO LATER THAN 6TH DIV. OF START SEGMENT. START PULSE SHALL END NO EARLIER THAN 94TH DIV. OF START SEGMENT AND END NO LATER THAN 6TH DIV. OF NO. 1. SEGMENT.
- (4) SPACING PULSE MAY HAVE A BREAK PROVIDED THE BREAK IS NOT OVER ONE DIVISION WIDE AND IT DOES NOT OCCUR PRIOR TO 95TH DIV. OF PULSE UNDER OBSERVATION.

SEE TABLE 1-1 FOR PERMISSIBLE WIDTH OF BREAK AT SPEED OF OPERATION.

2.14 Keyboard Mechanism continued

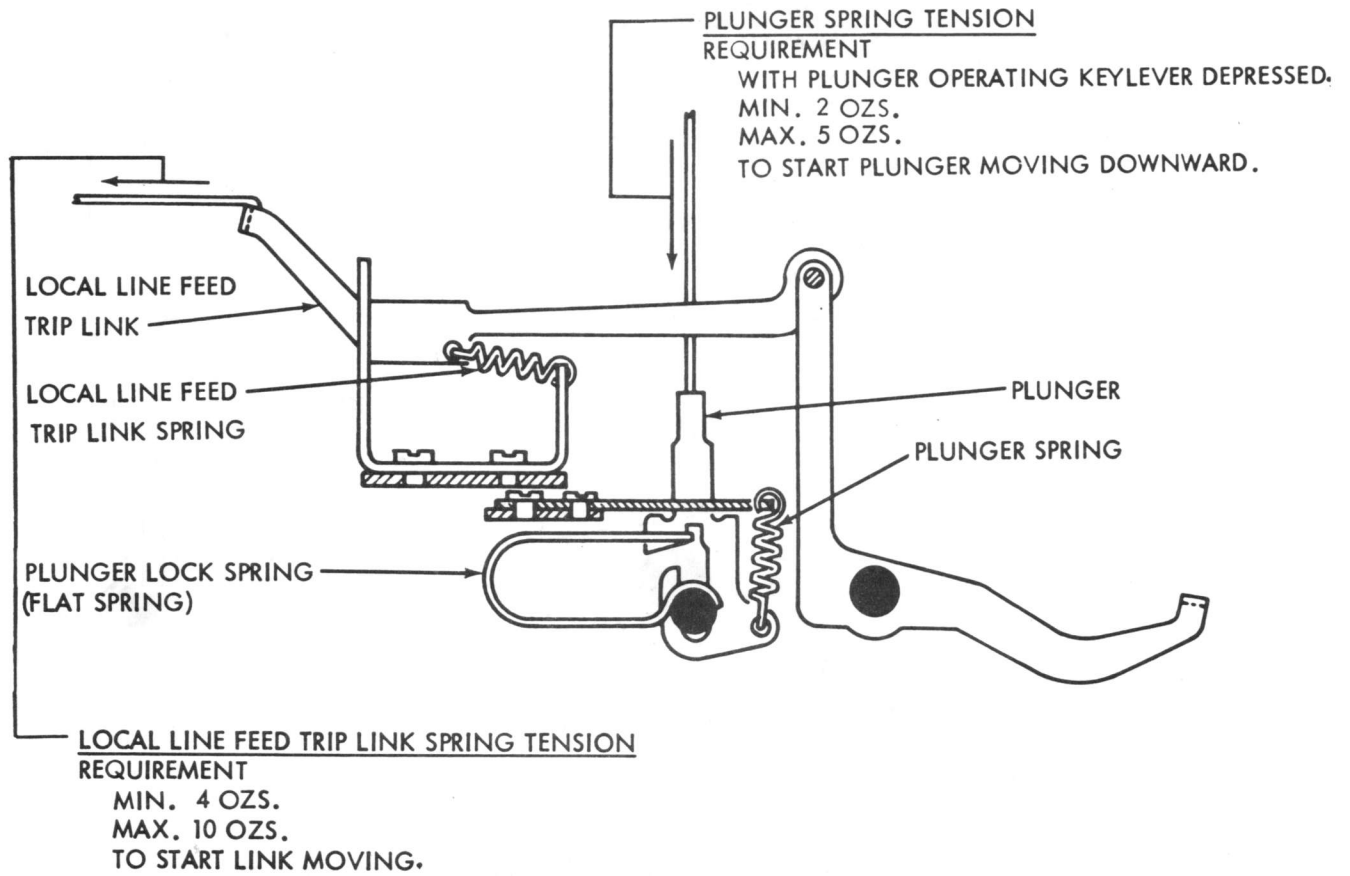

2.15 Keyboard Mechanism continued

(A) CODE LEVER SPRING TENSION

- (1) REQUIREMENT  
MIN. 1 OZ.  
MAX. 2 OZS.  
TO START CODE LEVER MOVING DOWNWARD.
- (2) REQUIREMENT  
POWER ON.  
GENERATOR CLUTCH DISENGAGED.  
MIN. 3 OZS.  
MAX. 5 OZS.  
TO OPERATE KEYLEVER OR SPACE BAR.

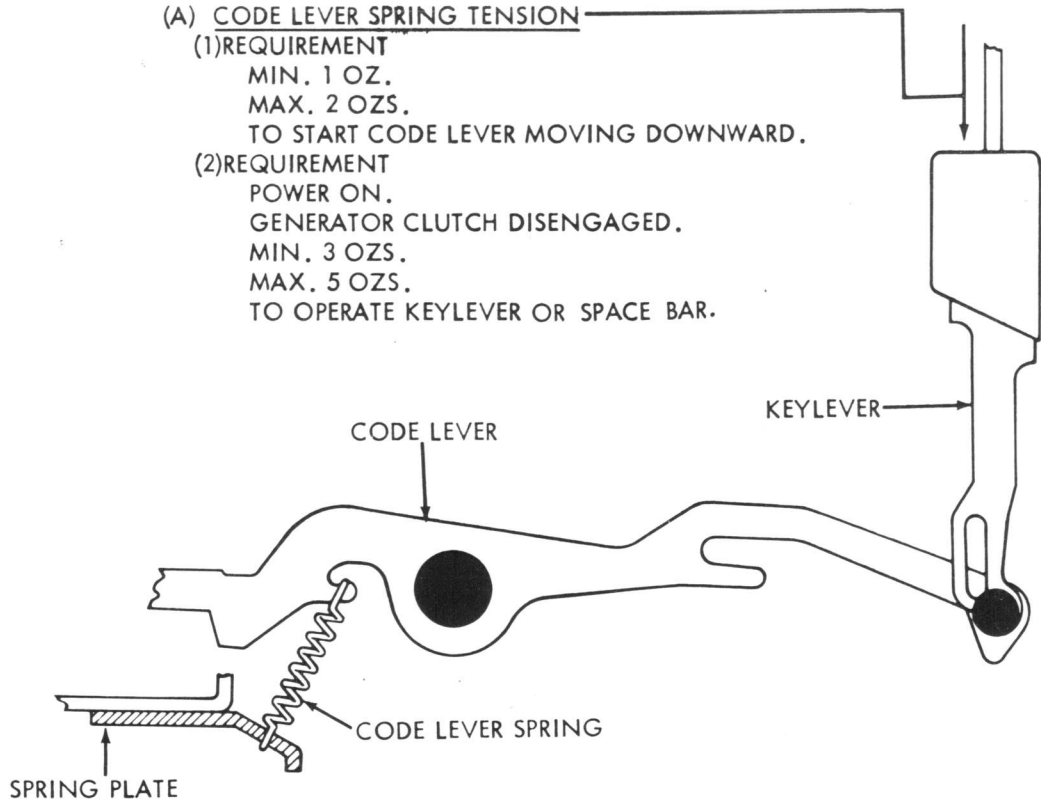

(B) LOCAL CARRIAGE RETURN FUNCTION BAIL SPRING TENSION

- (COMBINED CODE LEVER AND BAIL SPRING)
- REQUIREMENT  
MIN. 1 OZ.  
MAX. 3 OZS.  
TO MOVE KEYLEVER DOWNWARD.

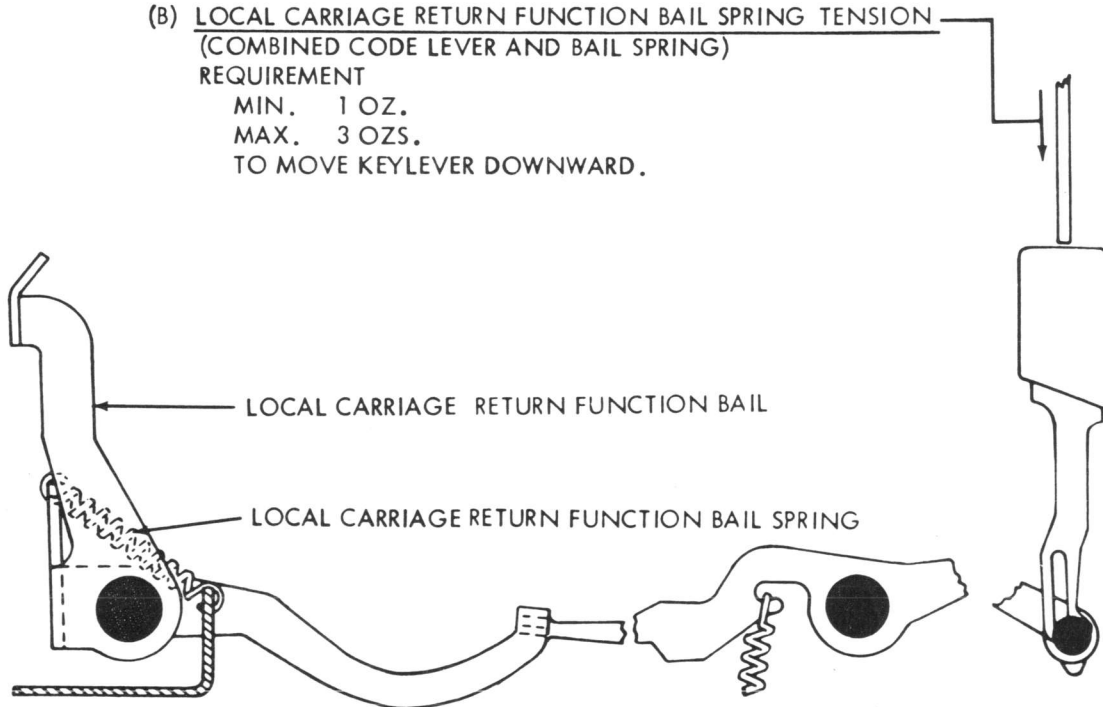

2.16 Codebar Assembly and Signal Generator Mechanism continued

(B) TRANSFER LEVER LOCKING BAIL SPRING TENSION

REQUIREMENT

SPRING UNHOOKED FROM POST, CLUTCH DISENGAGED.  
 MIN. 5 OZS.  
 MAX. 6 OZS.  
 TO PULL TO INSTALLED LENGTH.

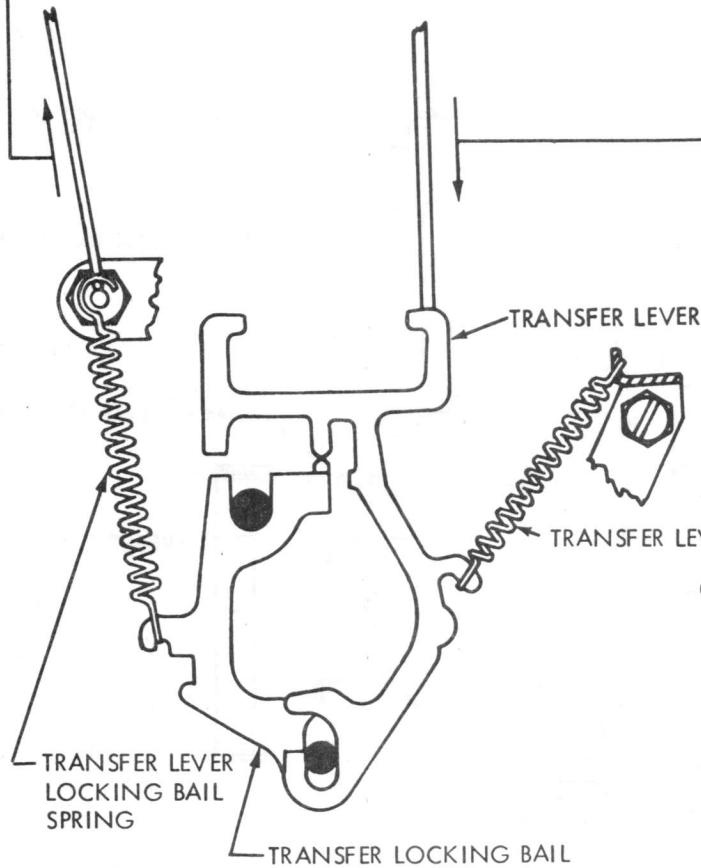

(A) TRANSFER LEVER SPRING TENSION

REQUIREMENT

CLUTCH DISENGAGED.  
 MIN. 1 1/2 OZS.  
 MAX. 2 1/2 OZS.  
 TO START EACH OF SEVEN LEVERS MOVING.

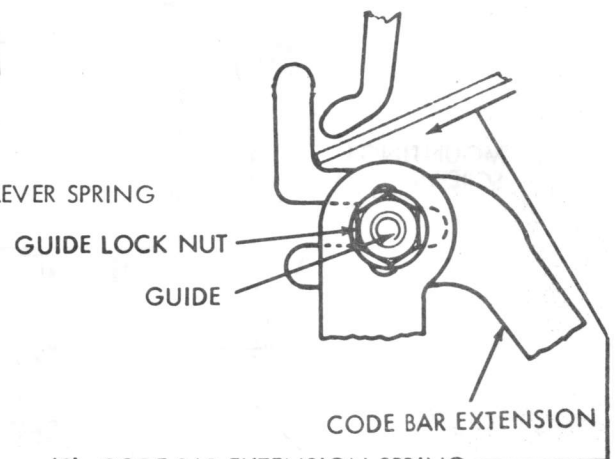

(C) CODE BAR EXTENSION SPRING

REQUIREMENT

MIN. 5 OZS.  
 MAX. 7 OZS.  
 TO START EACH EXTENSION MOVING.

2.17 Interrelated Features

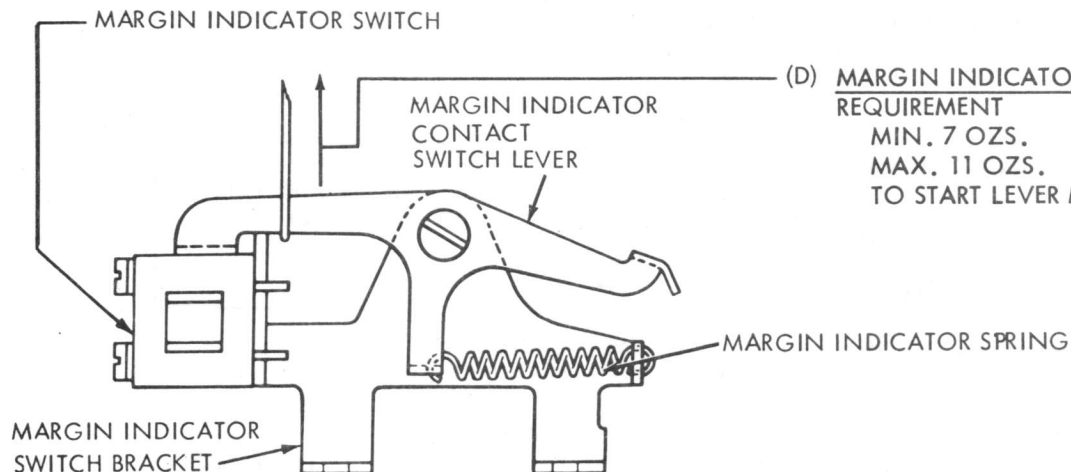

(D) MARGIN INDICATOR SPRING TENSION

REQUIREMENT

MIN. 7 OZS.  
 MAX. 11 OZS.  
 TO START LEVER MOVING.



SECTION 573-117-700

Note: Paragraph 2.18 through 2.23 apply to both typing and non-typing perforators.

2.18 Interrelated Features continued

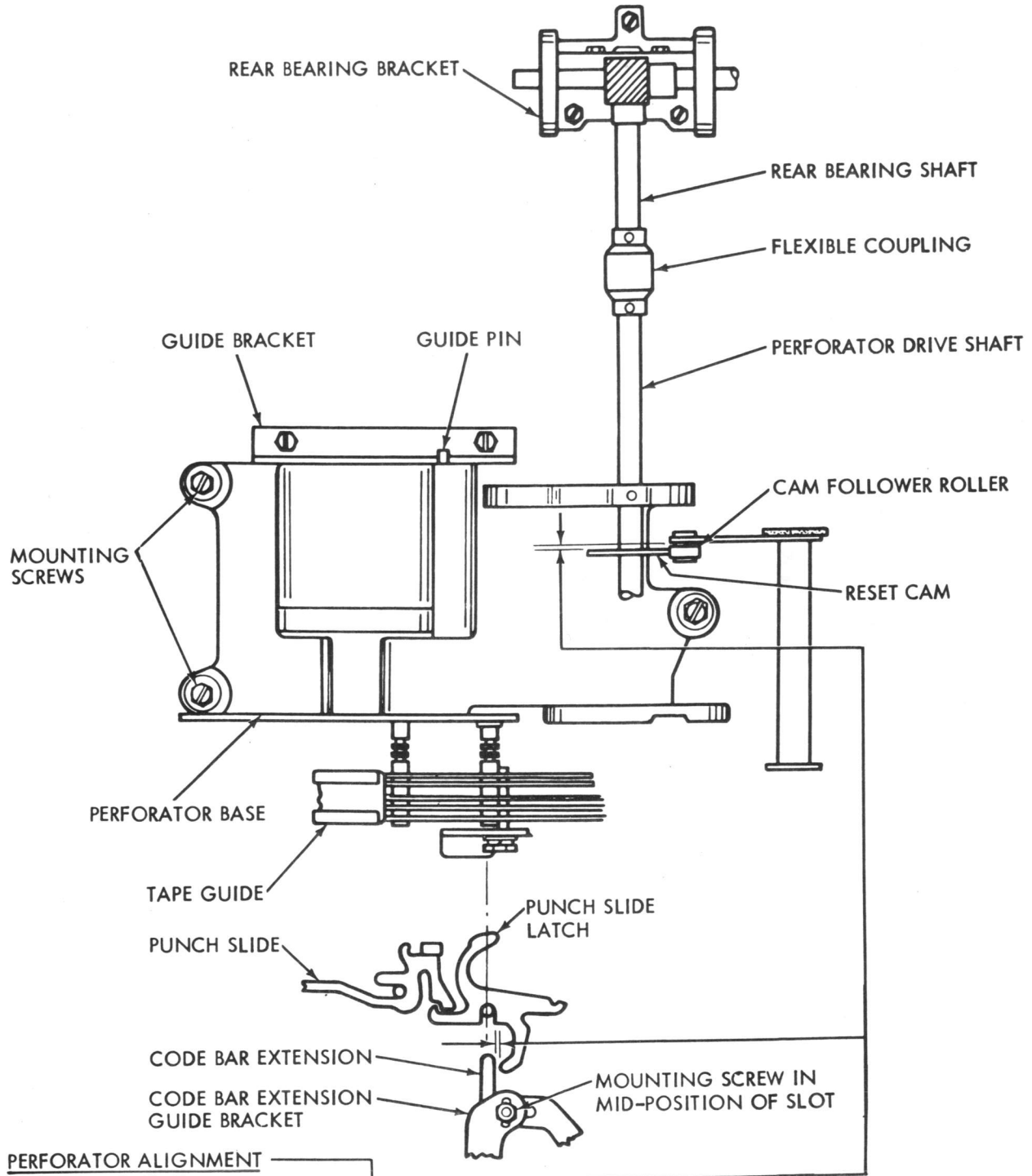

**PERFORATOR ALIGNMENT**

- (1) REQUIREMENT  
PUNCH SLIDE LATCHES SHOULD ALIGN WITH CODE BAR EXTENSIONS  
MIN. 0.010 -- MAX. 0.020 INCH TO RIGHT OF CODE BAR EXTENSION.
- (2) REQUIREMENT  
RESET CAM SHOULD ALIGN WITH ITS CAM FOLLOWER ROLLER  
APPROXIMATELY 0.030 INCH FORWARD OF THE REAR EDGE OF THE ROLLER.

CONTINUED ON FOLLOWING PAGE.

CONTINUED FROM PRECEDING PAGE.

TO ADJUST

LOOSEN SET SCREWS AND DISENGAGE FLEXIBLE COUPLINGS. LOOSEN TWO ALIGNMENT BRACKET SCREWS AND THREE PERFORATOR MOUNTING SCREWS. SET EXTENSION GUIDE PIN IN MIDDLE OF GUIDE BRACKET SLOT AND ALIGN PERFORATOR AND RESET CAM. TIGHTEN PERFORATOR MOUNTING SCREWS. POSITION ALIGNMENT BRACKET SO THAT IT CONTACTS PERFORATOR CASTING FOR ITS FULL LENGTH, AND TIGHTEN SCREWS. POSITION REAR BEARING BRACKET UNTIL PERFORATOR DRIVE SHAFT LINES UP WITH BEARING BRACKET SHAFT. A STRAIGHT-EDGE RULE APPLIED TO THE CENTER OF THE BEARING BRACKET SHAFT SHOULD ALSO EXTEND THROUGH THE CENTER OF THE PERFORATOR DRIVE SHAFT. TIGHTEN SCREWS, AND ENGAGE THE COUPLING, IF NECESSARY, REFINE LINE UP OF PUNCH SLIDE LATCHES AND CODE BAR EXTENSIONS BY ADJUSTING THE CODE BAR EXTENSION GUIDE BRACKET IN ITS MOUNTING HOLES.

2.19 Interrelated Features continued

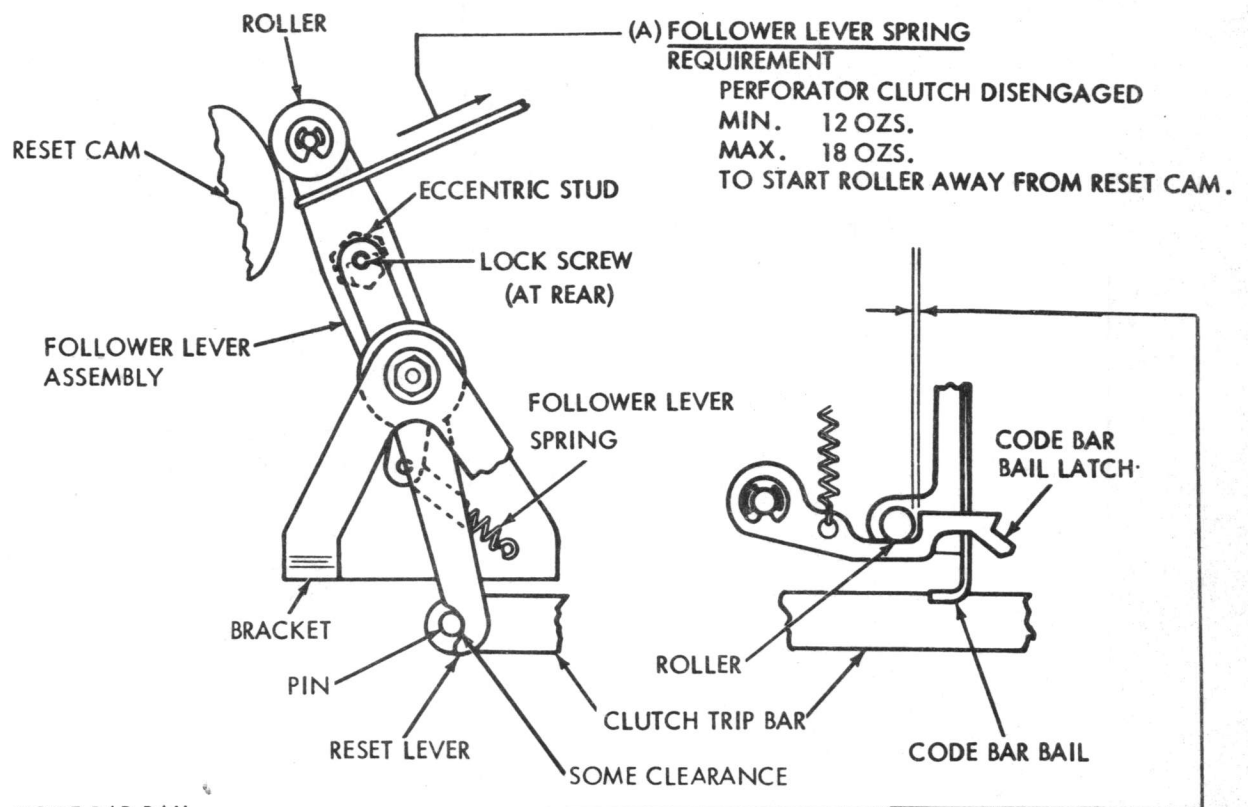

(B) CODE BAR BAIL REQUIREMENT

CONTROL KNOB IN T POSITION. CODE BAR BAIL AT EXTREME LEFT. CLEARANCE BETWEEN CODE BAR BAIL LATCH LEVER AND ROLLER.

MIN. SOME --- MAX. 0.006 INCH

TO ADJUST

POSITION ECCENTRIC STUD WITH LOCK SCREW LOOSENED TO MEET REQUIREMENT. RECHECK AFTER TIGHTENING LOCK SCREW.

TO CHECK

WITH ALL CLUTCHES LATCHED, DEPRESS LTRS KEY. AFTER CODE BARS HAVE MOVED TO RIGHT, THERE MUST BE SOME CLEARANCE BETWEEN FOLLOWER RESET LEVER AND CLUTCH TRIP BAR PIN.

2.20 Interrelated Features continued

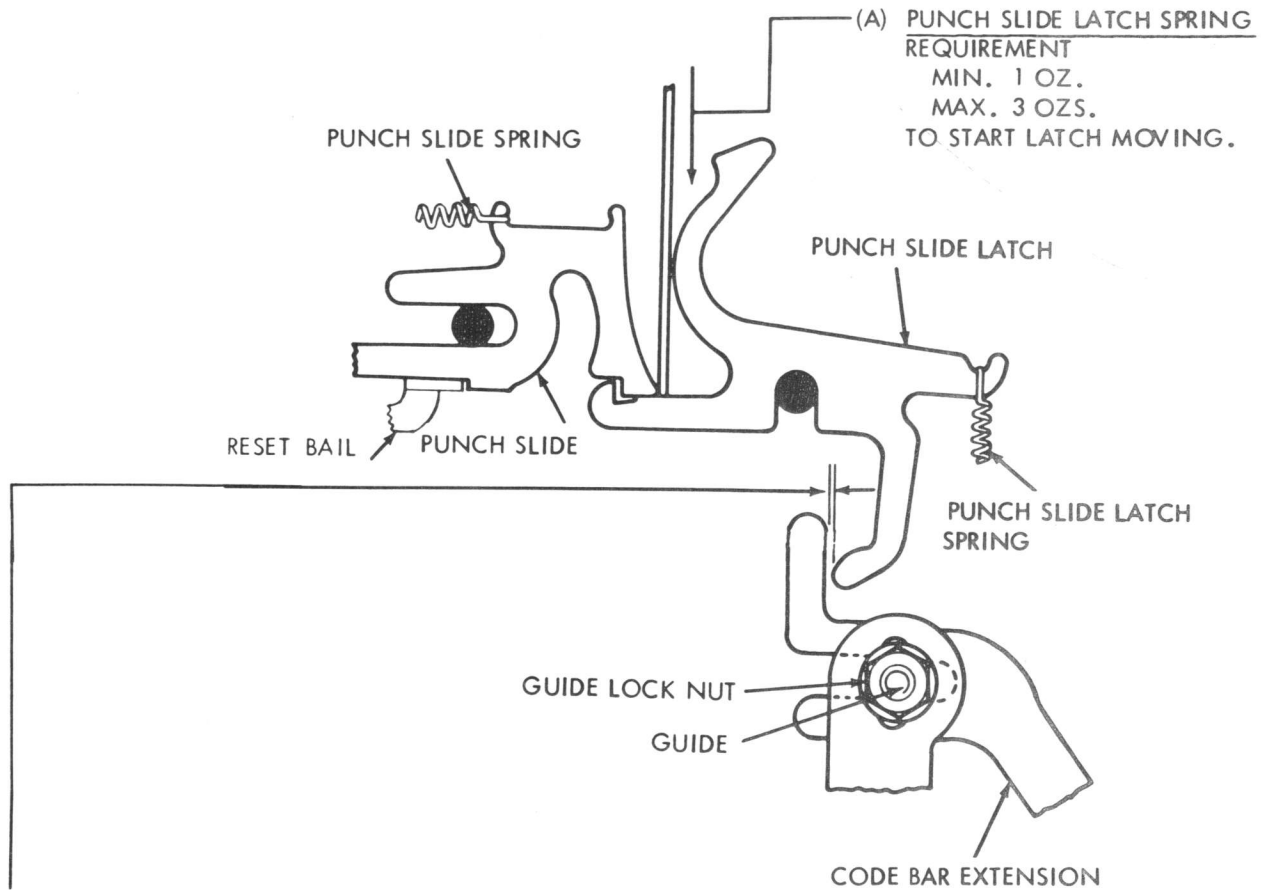

(A) PUNCH SLIDE LATCH SPRING  
 REQUIREMENT  
 MIN. 1 OZ.  
 MAX. 3 OZS.  
 TO START LATCH MOVING.

(B) CODE BAR EXTENSION AND PUNCH SLIDE LATCH

(1) REQUIREMENT

CONTROL KNOB IN T POSITION, BLANK KEYLEVER DEPRESSED. PUNCH SLIDE LATCHED. PLAY BETWEEN CODE BAR EXTENSIONS AND CODE BARS TAKEN UP BY MOVING AND HOLDING EXTENSIONS AT ENGAGEMENT WITH CODE BARS. CLEARANCE SHOULD BE MIN. SOME --- MAX. 0.010 INCH

BETWEEN CODE BAR EXTENSIONS AND CLOSEST PUNCH SLIDE LATCH.

(2) REQUIREMENT

LTRS KEYLEVER DEPRESSED. CODE BAR EXTENSIONS SHOULD ROTATE PUNCH SLIDE LATCHES TO RELEASE ALL PUNCH SLIDES. CHECK DYNAMIC OPERATION BY DEPRESSING THE "REPEAT" AND "BLANK" KEY SIMULTANEOUSLY.

(3) ON KEYBOARD PERFORATORS NOT HAVING THE "BLANK" KEY, OPERATE THE "BLANK" CODE BAR LEVER BY LIFTING WITH A SPRING HOOK.

TO ADJUST POSITION GUIDE VERTICALLY WITH GUIDE LOCK NUT LOOSENED TO OBTAIN REQUIRED CLEARANCE. TIGHTEN LOCK NUT.

2.21 Interrelated Features continued

**PERFORATOR CLUTCH RELEASE TRIP**

**REQUIREMENT**

PERFORATOR CLUTCH SHOULD TRIP CONSISTENTLY IN K-T POSITIONS WHEN BLANK AND REPEAT KEYLEVERS ARE DEPRESSED SIMULTANEOUSLY. WHEN THE CONTROL KNOB IS TURNED FROM K POSITION TO K-T POSITION, THE PERFORATOR CLUTCH SHOULD TRIP WHEN THE FIRST KEYLEVER IS DEPRESSED. CLEARANCE BETWEEN MAIN TRIP LEVER AND CLUTCH RELEASE

MIN. 0.015 INCH

MAX. 0.025 INCH

**TO ADJUST**

PLACE CONTROL KNOB IN T POSITION. LOOSEN MAIN TRIP LEVER LATCH CLAMP SCREWS AND MOVE LATCH TO EXTREME LEFT. STRIKE BLANK KEYLEVER. MOVE THE STOP BRACKET TO THE RIGHT UNTIL IT IS OUT OF ENGAGEMENT WITH THE LATCH. MOVE THE CLUTCH TRIP BAR EXTENSION TO THE RIGHT UNTIL IT LATCHES. POSITION MAIN TRIP LEVER LATCH TO RIGHT TO OBTAIN REQUIRED CLEARANCE. TIGHTEN SCREWS.

NOTE: CHECK FOR CLEARANCE BETWEEN RESET BAIL AND SLIDES WHEN THE RESET LEVER IS TRIPPED. REFINE ADJUSTMENT IF NECESSARY TO OBTAIN OPERATIONAL CLEARANCE.

**TO CHECK**

WITH THE STOP BRACKET SCREWS FRICTION TIGHT, MOVE THE STOP BRACKET SLOWLY TO THE LEFT UNTIL THE LATCH JUST TRIPS. TIGHTEN CLAMP SCREWS. TURN ON MOTOR. DEPRESS BLANK AND REPEAT KEYLEVERS SIMULTANEOUSLY. IF OPERATION IS SATISFACTORY, TURN TO K-T POSITION AND REPEAT. TURN TO K POSITION AND BACK TO K-T POSITION. DEPRESS A KEYLEVER. PERFORATOR CLUTCH SHOULD TRIP. IF IT DOES NOT, MOVE STOP BRACKET SLIGHTLY TO THE RIGHT AND REPEAT THE ABOVE ADJUSTMENT.

NOTE: IF KEYBOARD DOES NOT HAVE BLANK KEYLEVER USE "T" KEYLEVER INSTEAD OF BLANK.

**CLUTCH TRIP BAR LINK RETURN SPRING**

**REQUIREMENT**

CLUTCH DISENGAGED AND IN K-T POSITION.

MIN. 4 OZS.

MAX. 6 OZS.

TO START MAIN TRIP LEVER LATCH MOVING.

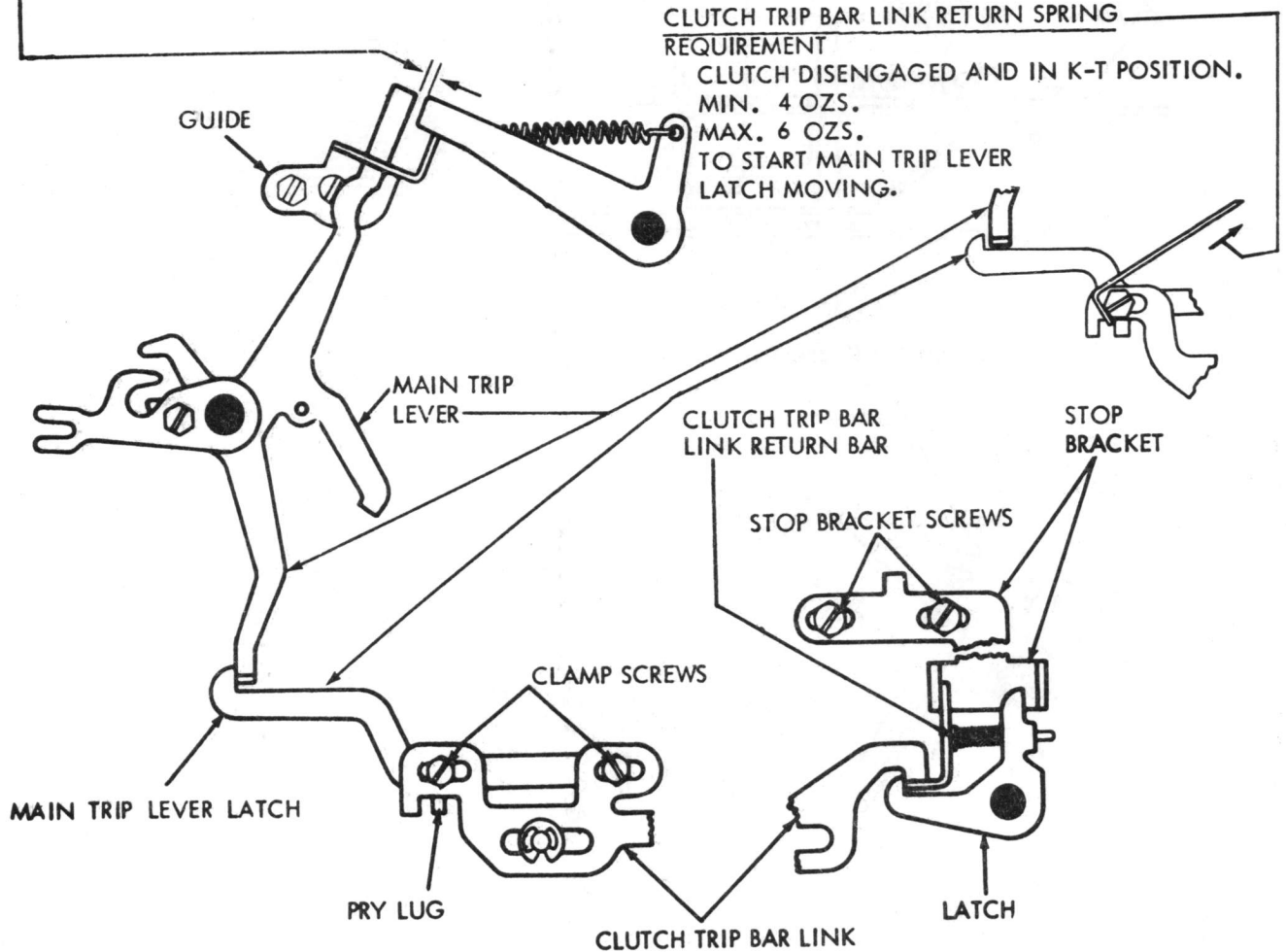

2.22 Interrelated Features continued

CODE BAR EXTENSION BLOCKING ASSEMBLY

REQUIREMENT

SELECTOR SWITCH IN K POSITION. CODE BAR EXTENSIONS AND CHARACTER COUNTER BARS SHOULD NOT OPERATE.

(1) CLEARANCE BETWEEN RIGHT END AT CODE BAR EXTENSIONS AND CODE BARS.

MIN. SOME

MAX. 0.015 INCH

(2) CLEARANCE BETWEEN BLOCKING LEVER AND SIDE OF NOTCH IN CHARACTER COUNTER CODE BARS. BAR WITH CLOSEST GAP

MIN. SOME

MAX. 0.010 INCH

TO ADJUST

WITH CLUTCH LATCHED, TURN CONTROL KNOB TO THE K POSITION. STRIKE LTRS KEYLEVER AND ROTATE SIGNAL GENERATOR SHAFT TO RETURN CODE BARS TO EXTREME LEFT. WITH ADJUSTING SCREW FRICITION TIGHT, POSITION EXTENSION BAIL TO OBTAIN REQUIREMENT (1) AND POSITION BLOCKING LEVER TO OBTAIN REQUIREMENT (2) MAKE CERTAIN THAT THE CODE BAR EXTENSION BAIL IS FREE ON ITS GUIDE POST. TEST OPERATION IN K, K-T AND T POSITIONS.

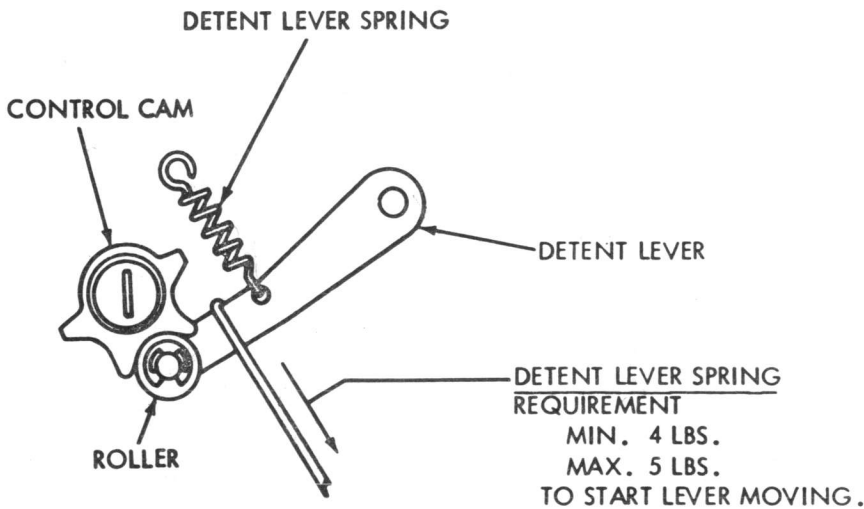
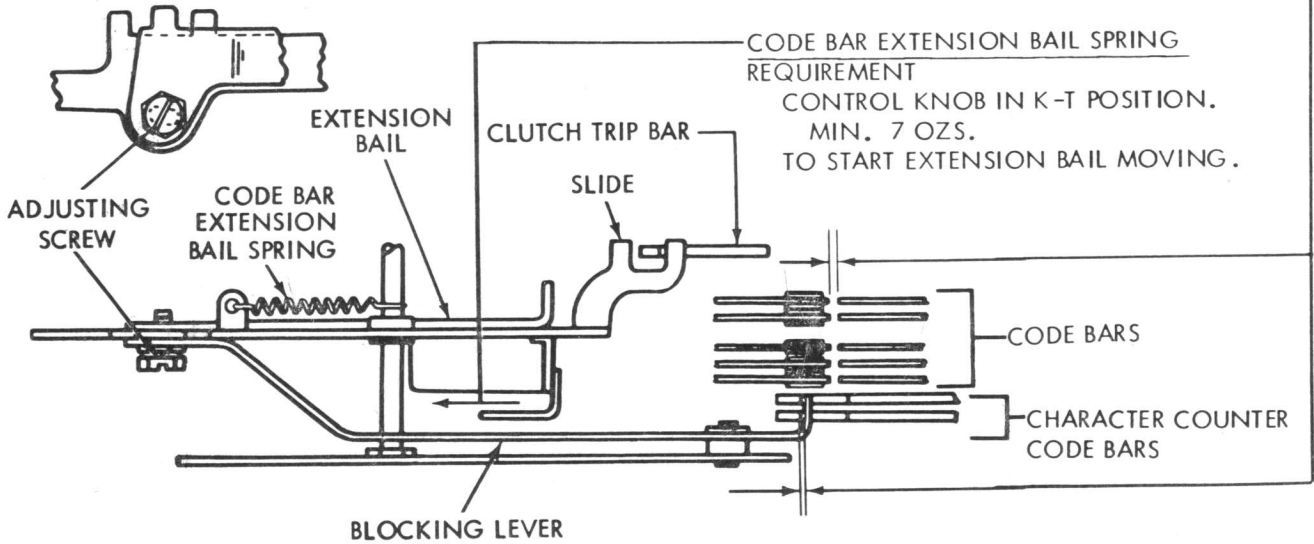



2.23 Interrelated Features continued

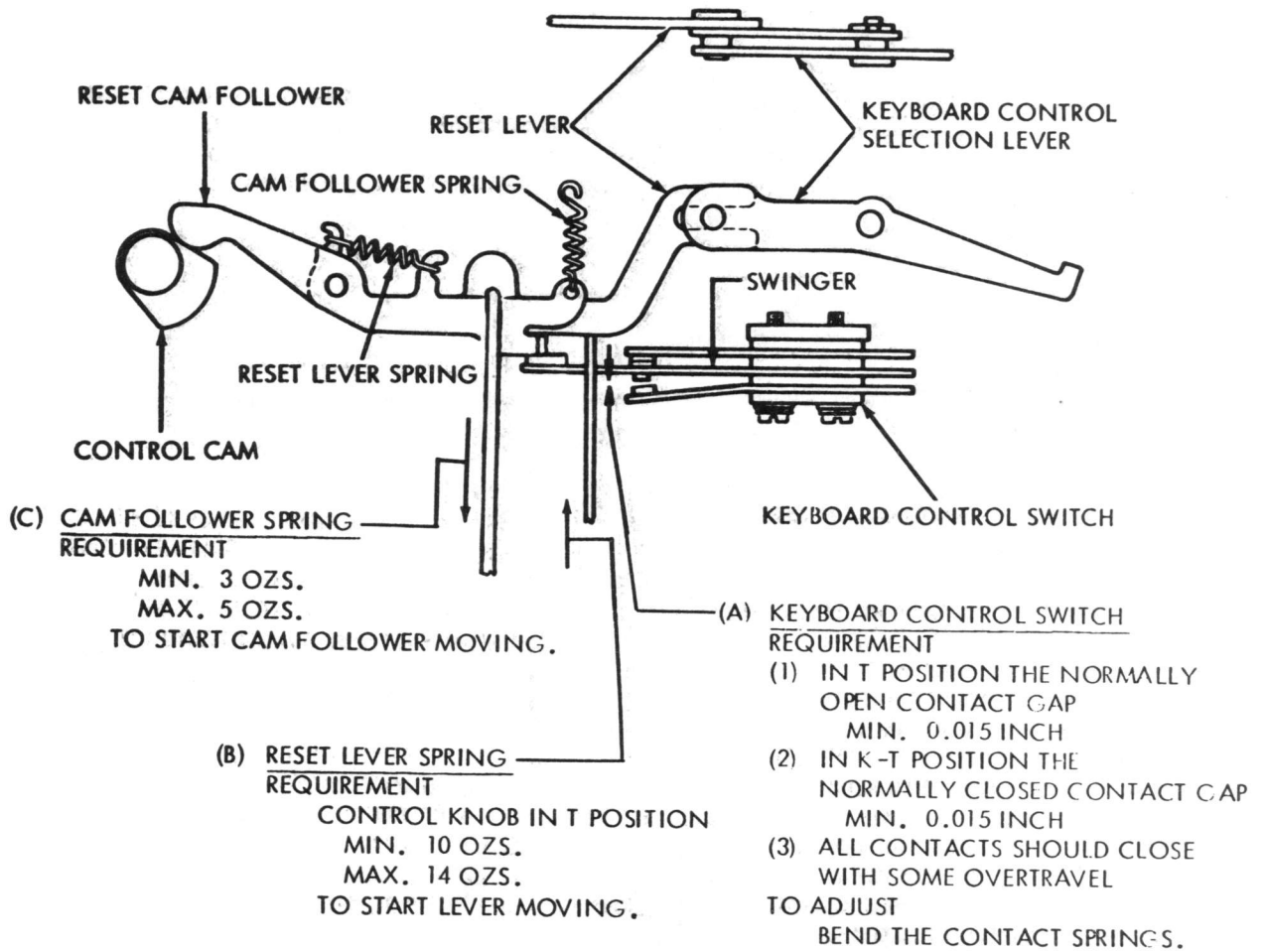

2.24 Interrelated Features continued

CAUTION

IF THE MOTOR SHOULD BECOME BLOCKED FOR SEVERAL SECONDS, THE THERMAL CUT-OUT SWITCH WILL BREAK THE CIRCUIT. SHOULD THIS HAPPEN, ALLOW THE MOTOR TO COOL AT LEAST 5 MINUTES BEFORE MANUALLY DEPRESSING THE RED BUTTON. AVOID REPEATED DEPRESSION.

SYNCHRONOUS MOTOR POSITIONING REQUIREMENT

TWO OILERS SHOULD BE UPWARD AND APPROXIMATELY EQUIDISTANT FROM A VERTICAL LINE THROUGH THE MOTOR SHAFT.  
TO ADJUST POSITION THE MOTOR WITH BOTH CLAMP SCREWS LOOSENED.

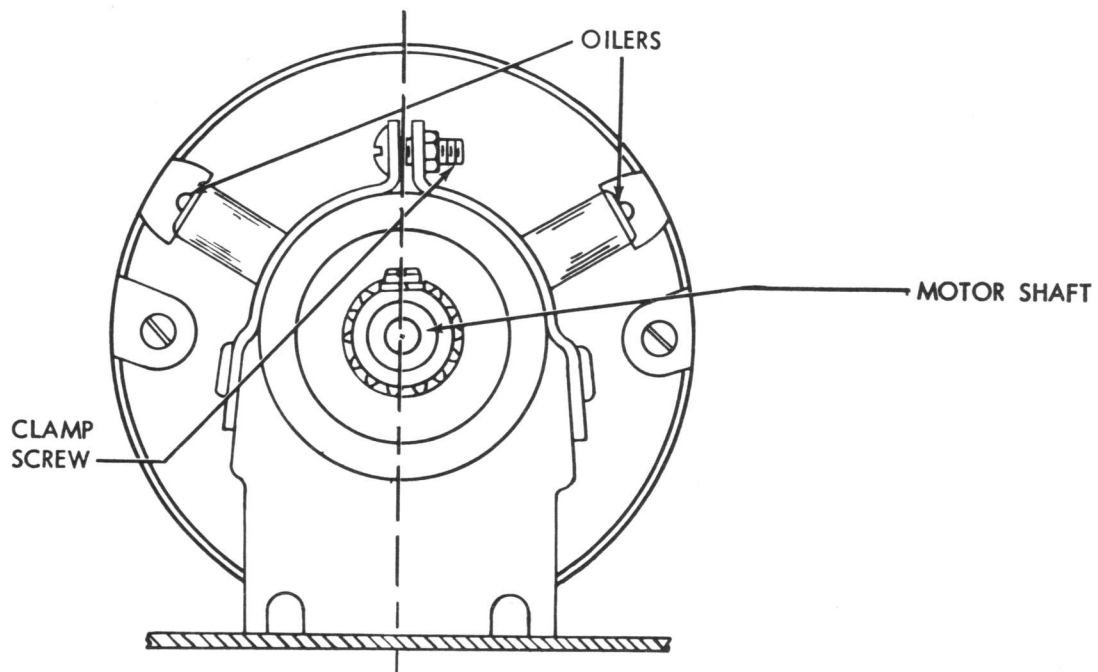

2.25 Interrelated Features continued

(2) REQUIREMENT  
 BARELY PERCEPTIBLE BACKLASH BETWEEN THE INTERMEDIATE DRIVING GEAR AND THE INTERMEDIATE DRIVEN GEAR AT THE CLOSEST POINT.

TO ADJUST  
 RAISE OR LOWER THE FRONT END OF THE INTERMEDIATE GEAR BRACKET BY MEANS OF THE FILLISTER HEAD ADJUSTING AND CLAMPING SCREWS LOCATED AT THE FRONT END OF THE BRACKET. REFINE REQUIREMENTS IF NECESSARY.

INTERMEDIATE GEAR BRACKET

(1) REQUIREMENT

BARELY PERCEPTIBLE BACKLASH BETWEEN THE TYPING UNIT DRIVEN GEAR AND THE TYPING UNIT DRIVING GEAR AT THE CLOSEST POINT.

TO ADJUST

POSITION THE COMPLETE INTERMEDIATE GEAR MECHANISM BRACKET BY UTILIZING THE ADJUSTING SLOTS WITH THE THREE HEXAGON HEAD SCREWS LOOSENED. ALIGN THE GEARS AT THIS TIME.

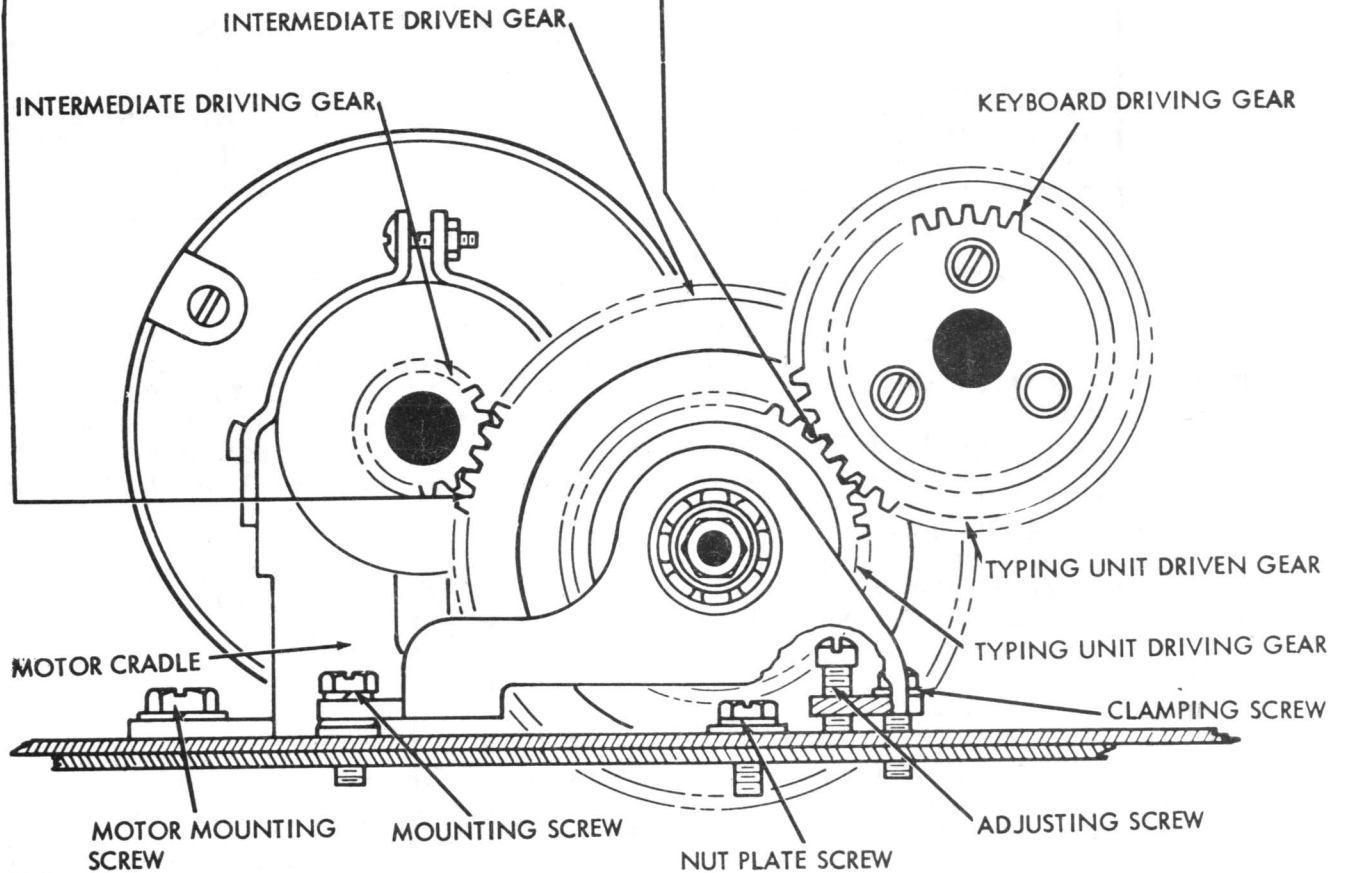

2.26 Interrelated Features continued

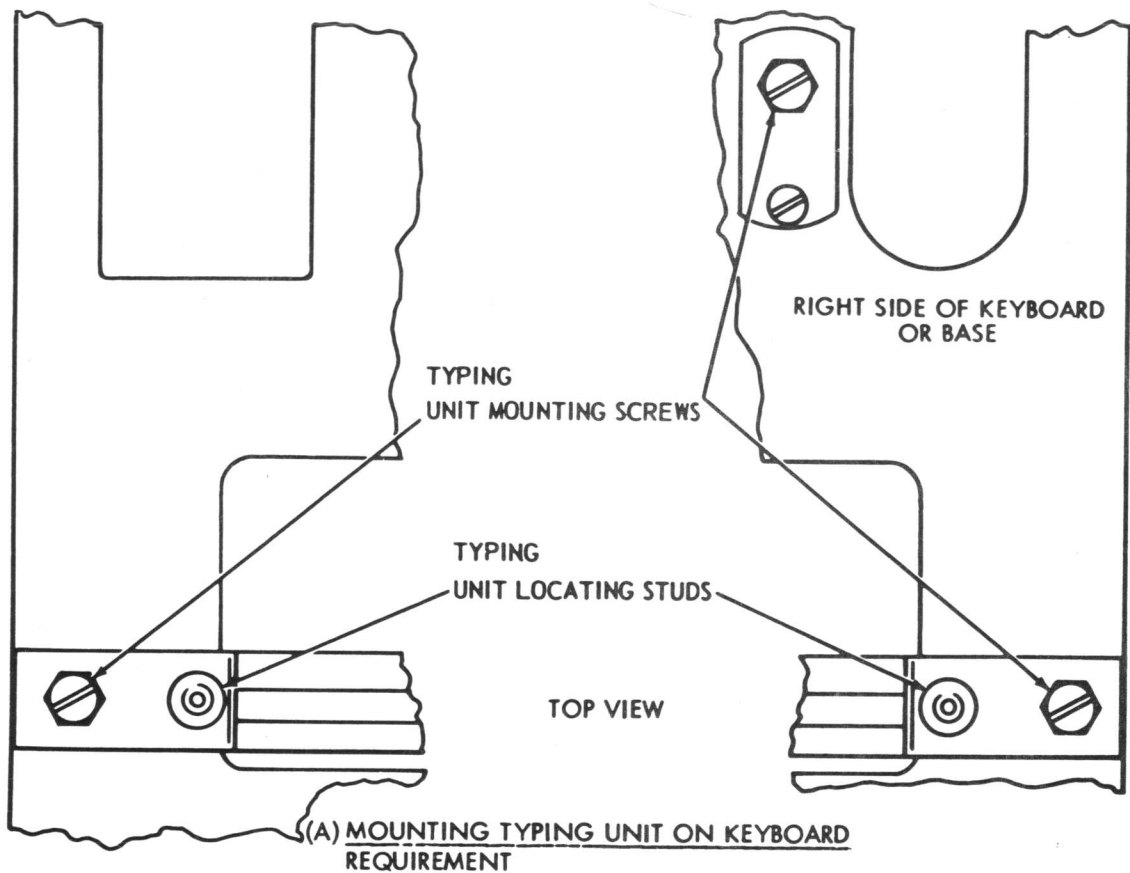

(B) SIGNAL GENERATOR FRAME REQUIREMENT  
 WITH TYPING UNIT MOUNTED IN POSITION, THERE SHOULD BE A PERCEPTIBLE AMOUNT OF BACKLASH BETWEEN THE SIGNAL GENERATOR DRIVEN GEAR AND THE SIGNAL GENERATOR DRIVING GEAR AT THE POINT WHERE BACKLASH IS THE LEAST.  
 TO ADJUST REMOVE THE SIGNAL GENERATOR FRAME REAR MOUNTING SCREW AND LOOSEN THE SHIM SCREW. ADD OR SUBTRACT SHIMS AS REQUIRED.

WHEN PLACING THE TYPING UNIT ON THE BASE HOLD IT TILTED SLIGHTLY TO THE RIGHT AND LOWER THE RIGHT END INTO ENGAGEMENT WITH THE RIGHT LOCATING STUD. WHILE EASING THE LEFT END DOWNWARD ROTATE THE MOTOR BY HAND TO PROPERLY MESH THE GEARS. SECURE BY FOUR MOUNTING SCREWS. ROTATE THE MOTOR BY HAND TO INSURE PROPER MESHING OF GEARS.

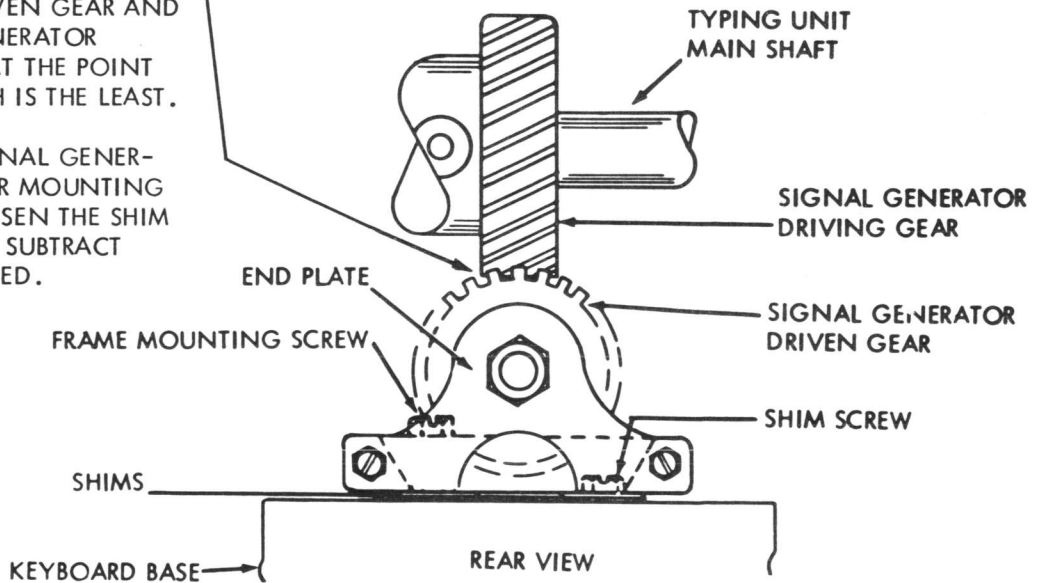

3. VARIABLE FEATURES

3.01 Electrical Line Break Mechanism

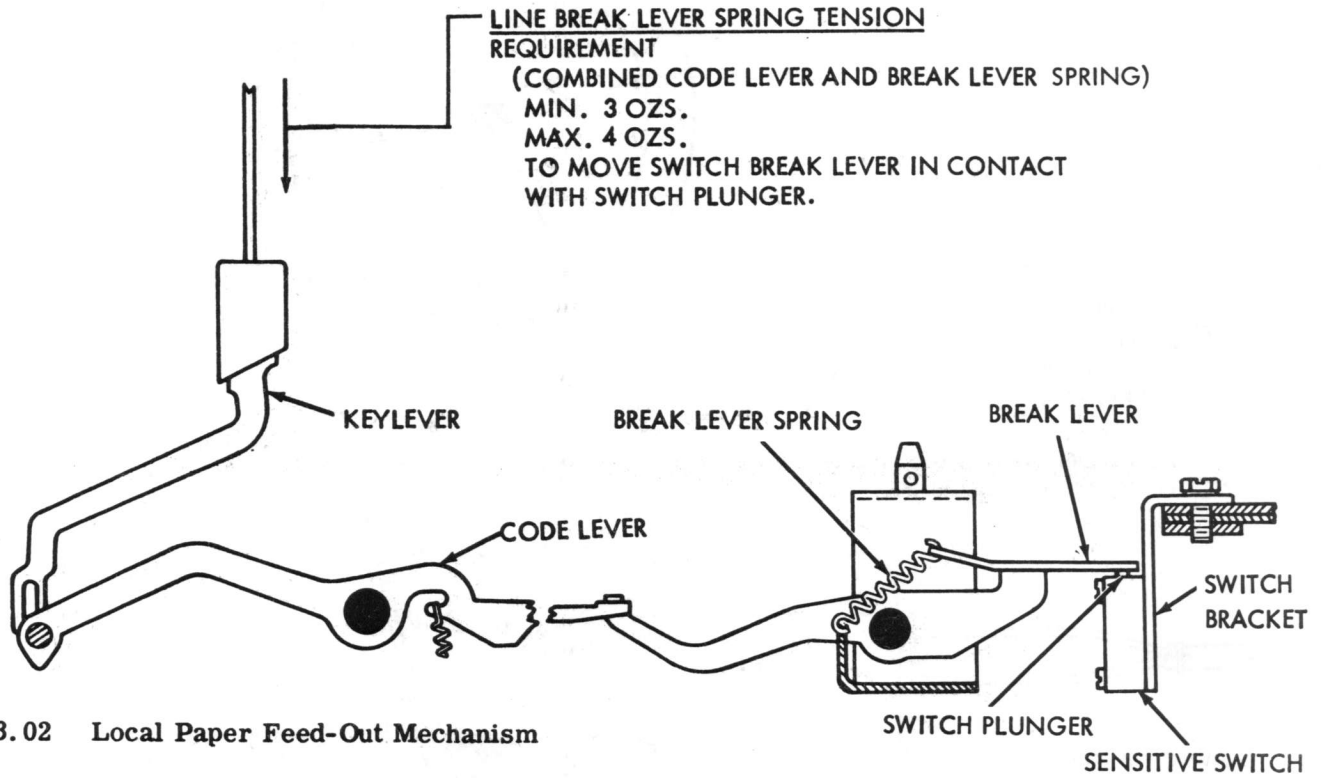

3.02 Local Paper Feed-Out Mechanism

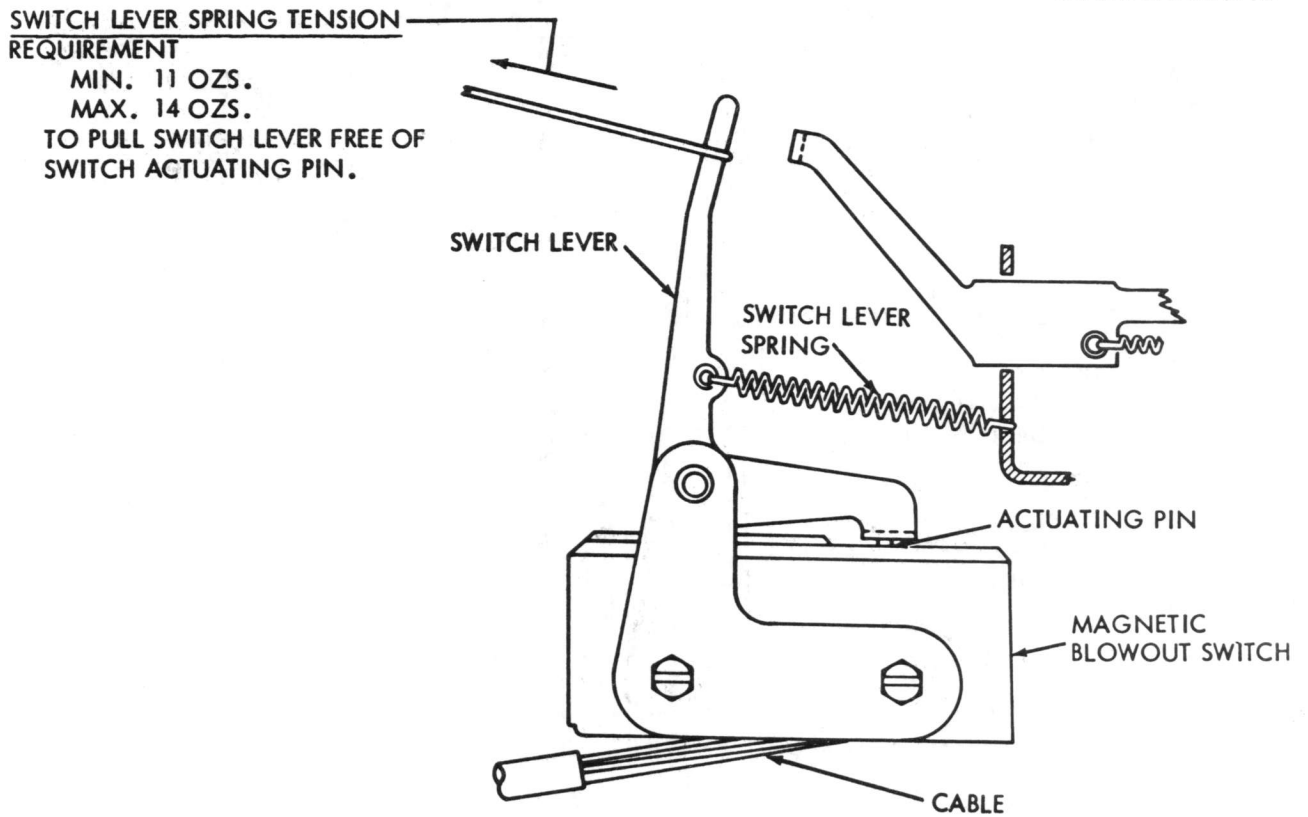

3.03 Tape Out Switch Mechanism

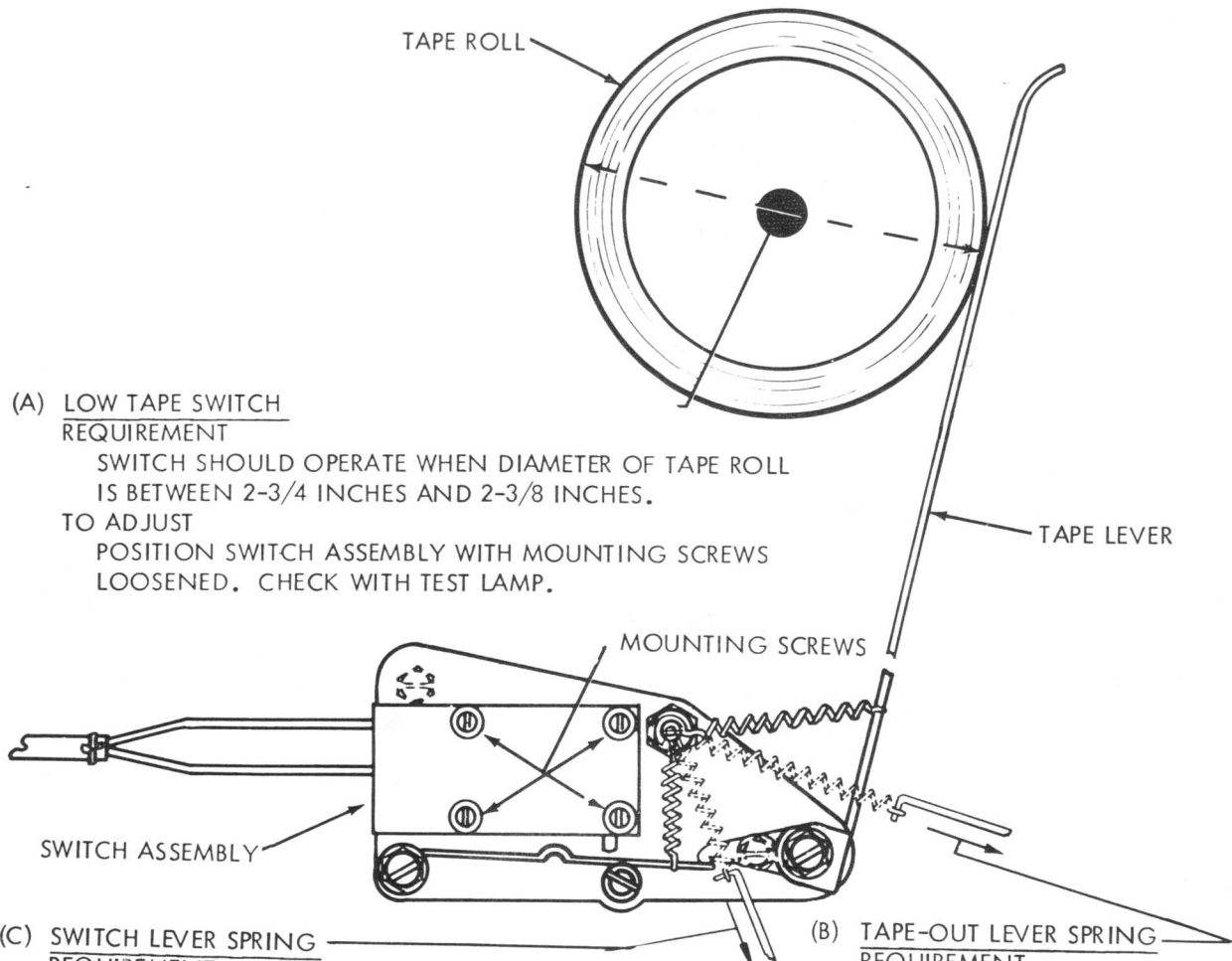

(A) LOW TAPE SWITCH REQUIREMENT

SWITCH SHOULD OPERATE WHEN DIAMETER OF TAPE ROLL IS BETWEEN 2-3/4 INCHES AND 2-3/8 INCHES.

TO ADJUST

POSITION SWITCH ASSEMBLY WITH MOUNTING SCREWS LOOSENED. CHECK WITH TEST LAMP.

(C) SWITCH LEVER SPRING REQUIREMENT

MIN. 6 OZS. --- MAX. 7 OZS.  
TO PULL SPRING TO LENGTH OF 1-1/4 INCHES

(B) TAPE-OUT LEVER SPRING REQUIREMENT

MIN. 6 OZS. --- MAX. 8 OZS.  
TO PULL SPRING TO LENGTH OF 1-17/32 INCHES.

3.04 Keyboard Lockbar Switch Mechanism

(D) KEYBOARD LOCK BAR SWITCH SPRING REQUIREMENT

LOCK BAR LATCHED (SEND KEYLEVER DEPRESSED IF EQUIPPED WITH ELECTRICAL LOCK-OUT)  
MIN. 8 OZS.  
MAX. 15 OZS.  
TO START SWITCH SPRING MOVING.

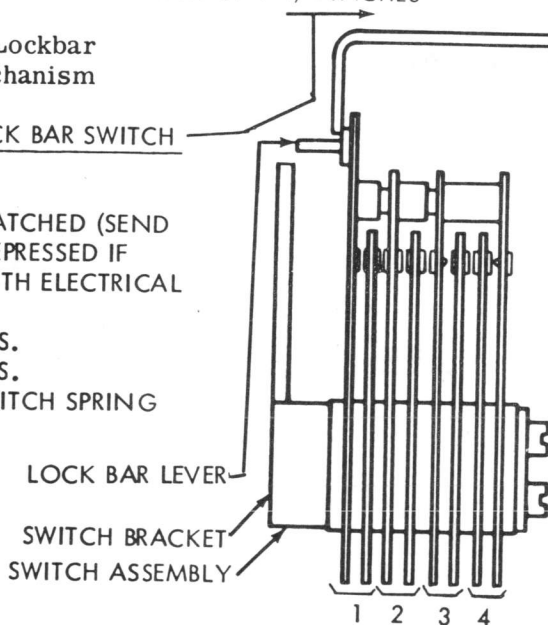

(E) KEYBOARD LOCK-BAR SWITCH REQUIREMENT

(1) REQUIREMENT  
WITH THE RECEIVE KEY DEPRESSED THE CONTACT GAP OF THE NORMALLY OPEN CONTACT (NO'S 1,2,3) SHOULD BE MIN. 0.008 INCH

(2) REQUIREMENT  
WITH THE SEND KEY DEPRESSED CONTACT GAP OF THE NORMALLY CLOSED CONTACT NO. 4 SHOULD BE MIN. 0.008 INCH

(3) REQUIREMENT  
ALL CONTACTS SHOULD CLOSE WITH SOME OVER-TRAVEL  
TO ADJUST BEND CONTACT SPRINGS

3.05 Character Counter Mechanism

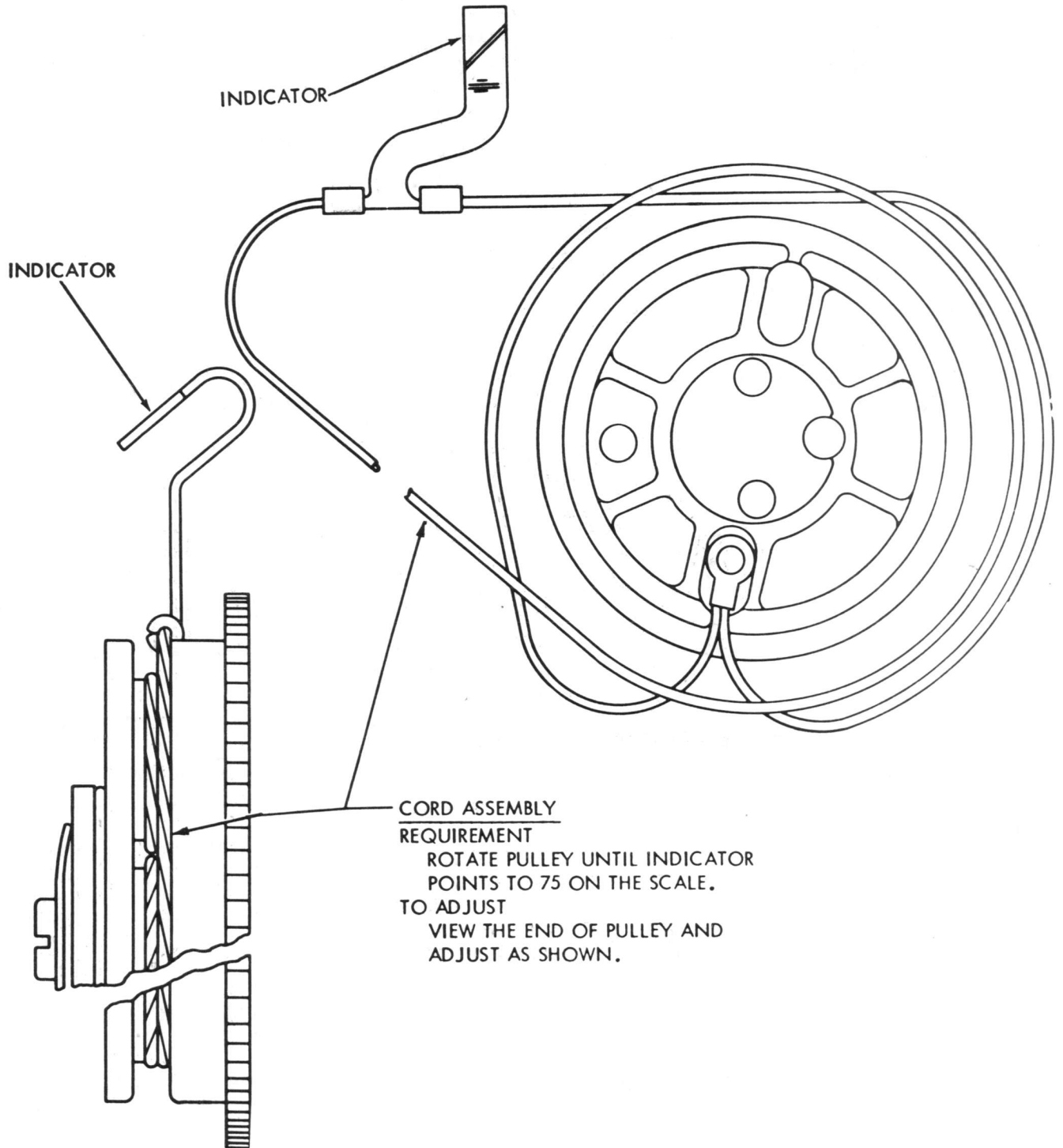



3.06 Character Counter Mechanism continued

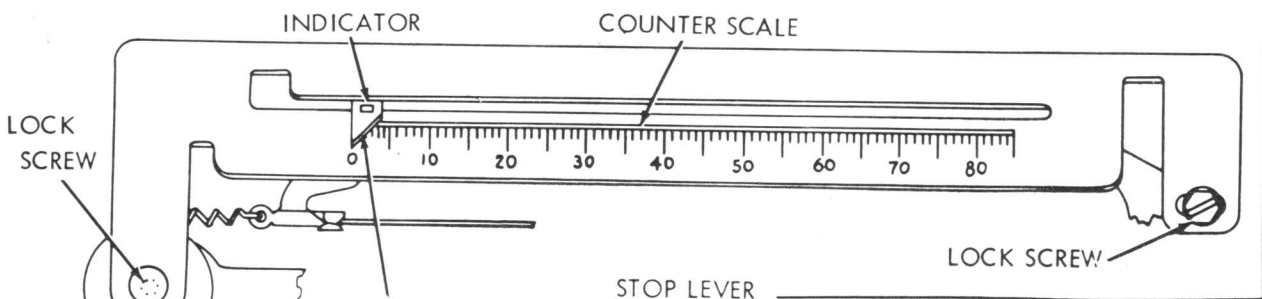
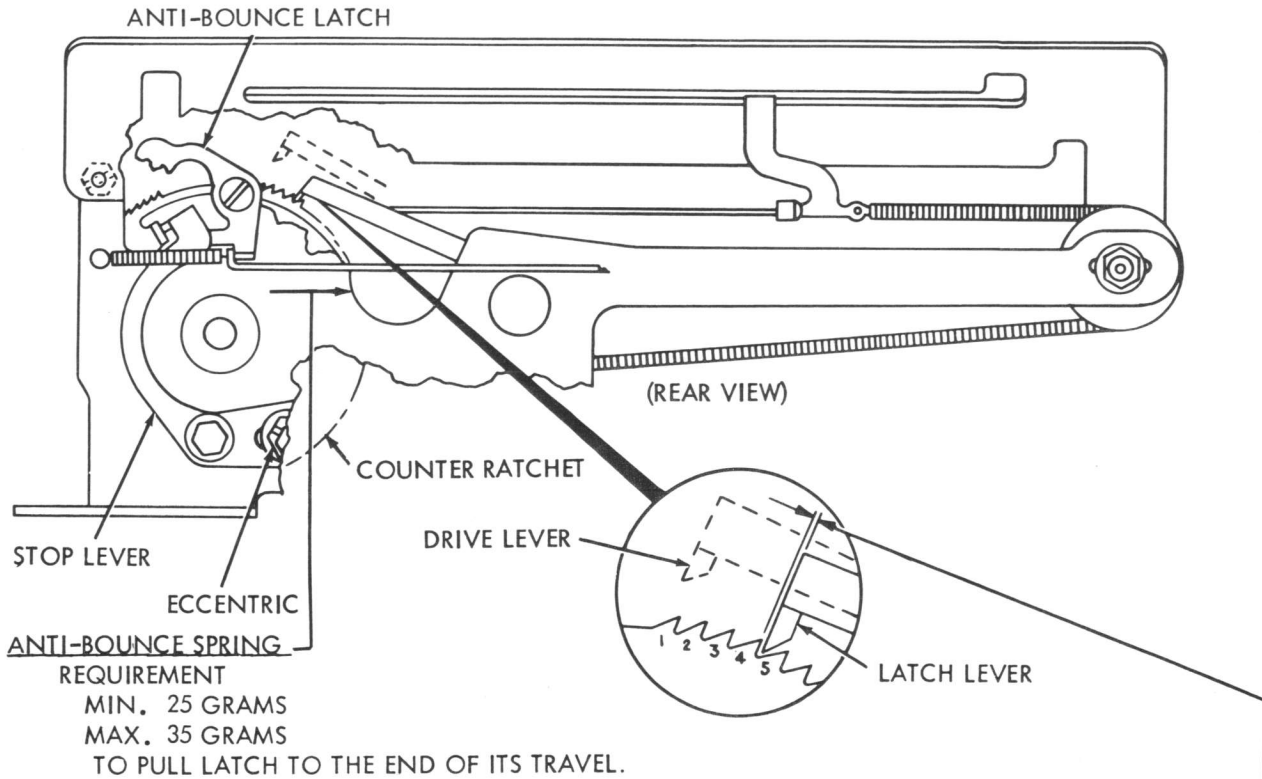

CHARACTER COUNTER SCALE

- (1) REQUIREMENT  
WHEN INDICATOR IS AT EXTREME LEFT OF SCALE, IT SHOULD POINT TO ZERO.  
TO ADJUST  
SET INDICATOR TO LEFT. LOOSEN LOCK SCREWS AND POSITION SCALE.
- (2) REQUIREMENT  
POINT OF INDICATOR SHOULD NOT TOUCH THROUGHOUT ITS ENTIRE TRAVEL.  
TO ADJUST  
FORM THE INDICATOR.

STOP LEVER

- (1) REQUIREMENT  
WITH THE COUNTER RATCHET FULLY RETURNED AND RESTING AGAINST ITS STOP LEVER, THE CLEARANCE BETWEEN THE LATCH LEVER AND THE FACE OF THE 4TH RATCHET TOOTH SHOULD BE  
MIN. 0.002 INCH  
MAX. 0.010 INCH
- (2) REQUIREMENT  
THE ANTI-BOUNCE LATCH SHOULD NOT INTERFERE WITH THE ROTATION OF THE RATCHET.  
TO ADJUST  
HOLD THE DRIVE LEVER OUT OF ENGAGEMENT WITH THE RATCHET AND ROTATE THE STOP LEVER ECCENTRIC.

## 3.07 Character Counter Mechanism continued

RATCHET DRUM ASSEMBLY RETURN SPRING REQUIREMENT

1/2 TO 1 1/2 OZS. WHEN INDICATOR POINTS TO 35 ON THE SCALE.

1 1/2 TO 2 1/2 OZS. WHEN INDICATOR POINTS TO 70 ON THE SCALE.

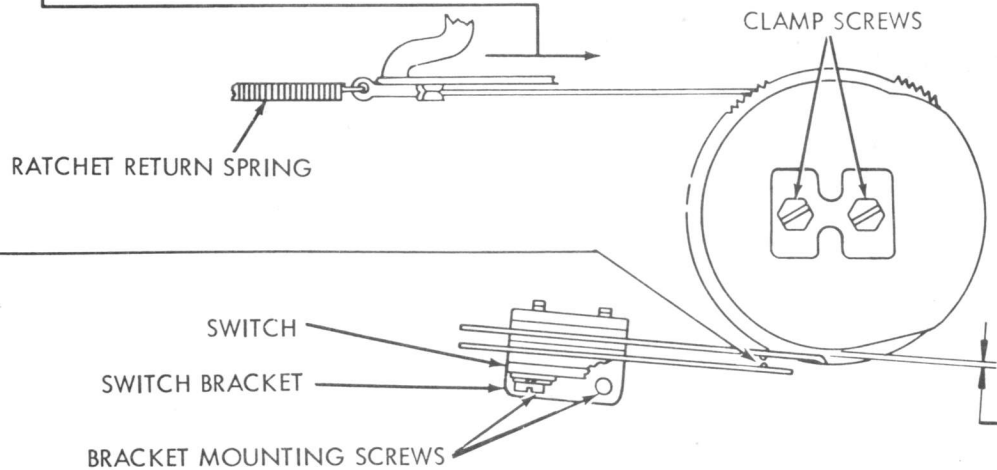
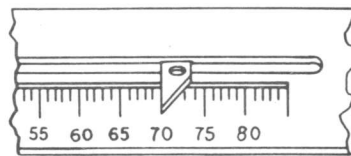
CHARACTER COUNTER END-OF-LINE SWITCH

## (1) REQUIREMENT

THE SWITCH SHOULD CLOSE AT A PRESET NUMBER OF CHARACTERS.

## (2) REQUIREMENT

BEFORE INSTALLING THE COUNTER ON THE KEYBOARD PERFORATOR, TIGHTEN THE CLAMP SCREWS AND SWITCH BRACKET MOUNTING SCREWS FRICTION TIGHT. WITH THE SWITCH LEAF SPRINGS APPROXIMATELY PARALLEL TO THE SWITCH MOUNTING BRACKET (GAGE BY EYE) AND WITH

MIN. 0.005 INCH --- MAX. 0.020 INCH

CLEARANCE BETWEEN THE LEAF SPRING SWITCH CONTACTS (BEND LOWER LEAF SPRING).

## TO ADJUST

POSITION SWITCH BRACKET UNTIL THE UPPER SWITCH LEAF SPRING CLEARS THE LOW OF THE CAM

MIN. SOME --- MAX. 0.025 INCH

CHECK CLOSEST POINT AND TIGHTEN BRACKET SCREWS. SET INDICATOR TO COUNT DESIRED AND ADJUST CAM UNTIL THE SWITCH JUST CLOSURES. TIGHTEN CLAMP SCREWS.

## TO CHECK OPERATION

MOVE RATCHET DRUM UNTIL THE INDICATOR TRAVERSES THE ENTIRE SCALE. THE SWITCH SHOULD CLOSE ON THE DESIRED COUNT, WITH A SMALL AMOUNT OF OVER-TRAVEL OF BOTH BLADES. IT MAY BE NECESSARY TO REFINE THE ABOVE ADJUSTMENTS WHEN OPERATING ON THE EXTREME ENDS OF THE 65 TO 80 CHARACTER RANGE.

3.08 Character Counter Mechanism continued

CHARACTER COUNTER STROKE

REQUIREMENT

WHEN CHARACTER AND REPEAT KEYS ARE DEPRESSED, THE COUNTER SHOULD OPERATE CONSISTENTLY IN T OR K-T POSITION. WHEN CARRIAGE RETURN KEY IS DEPRESSED, THE COUNTER SHOULD RESET WITHOUT BINDING. THE MECHANISM SHOULD COUNT THE FIRST CHARACTER ON A RESTART AFTER RESET CONDITION.

MIN. 0.006---MAX. 0.015 INCH

BETWEEN DRIVE LEVER AND RATCHET TOOTH, WHEN COUNTER IS SET NEAR MID-POINT OF ITS RANGE.

TO ADJUST

LOOSEN MOUNTING SCREWS. WITH KEYBOARD IN T POSITION, START MOTOR AND STRIKE CARRIAGE RETURN KEY, AND THEN E KEY. TURN OFF MOTOR. DEPRESS E KEY. POSITION CHARACTER COUNTER FRAME FOR CLEARANCE. TURN CONTROL KNOB TO K-T POSITION AND RECHECK. REFINE IF NECESSARY.

RESET LATCH LEVER AND DRIVE LEVER SPRING

REQUIREMENT

MIN. 1/2 OZ.

MAX. 1 OZ.

TO MOVE EITHER LEVER.

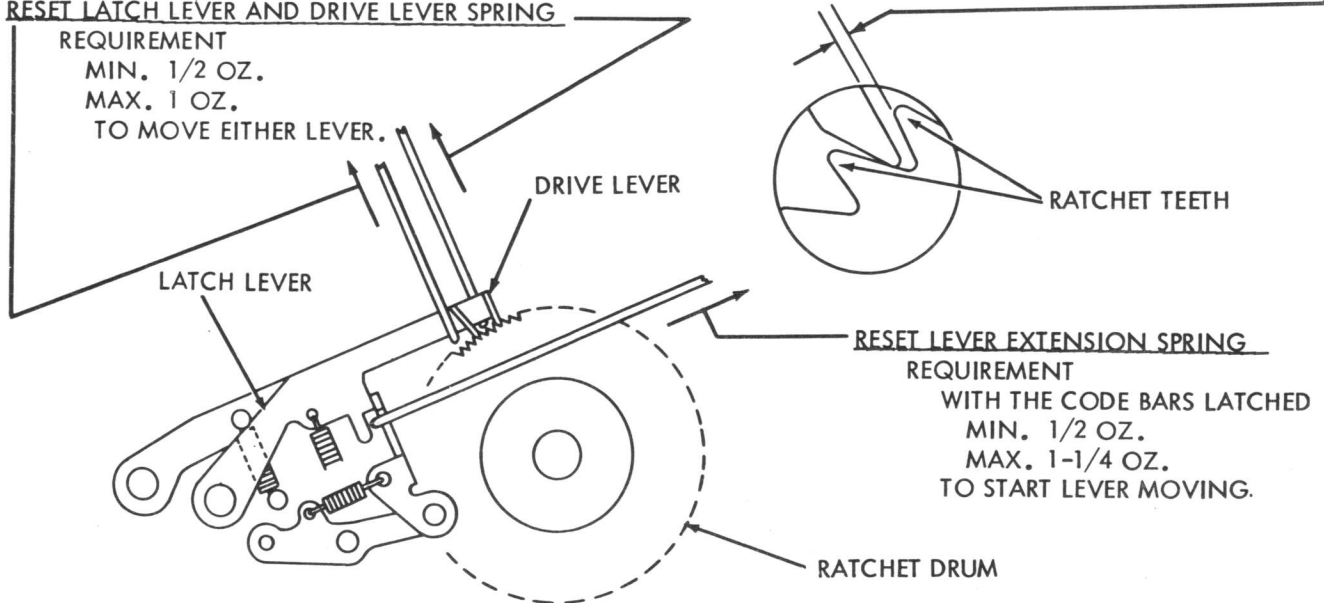

RESET LEVER EXTENSION SPRING

REQUIREMENT

WITH THE CODE BARS LATCHED

MIN. 1/2 OZ.

MAX. 1-1/4 OZ.

TO START LEVER MOVING.

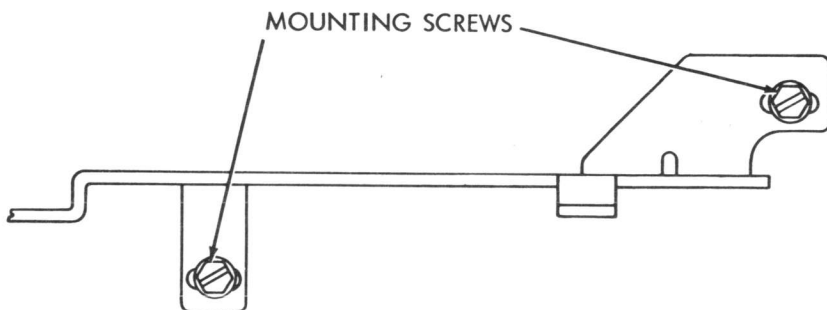

3.09 Repeat On Space Mechanism

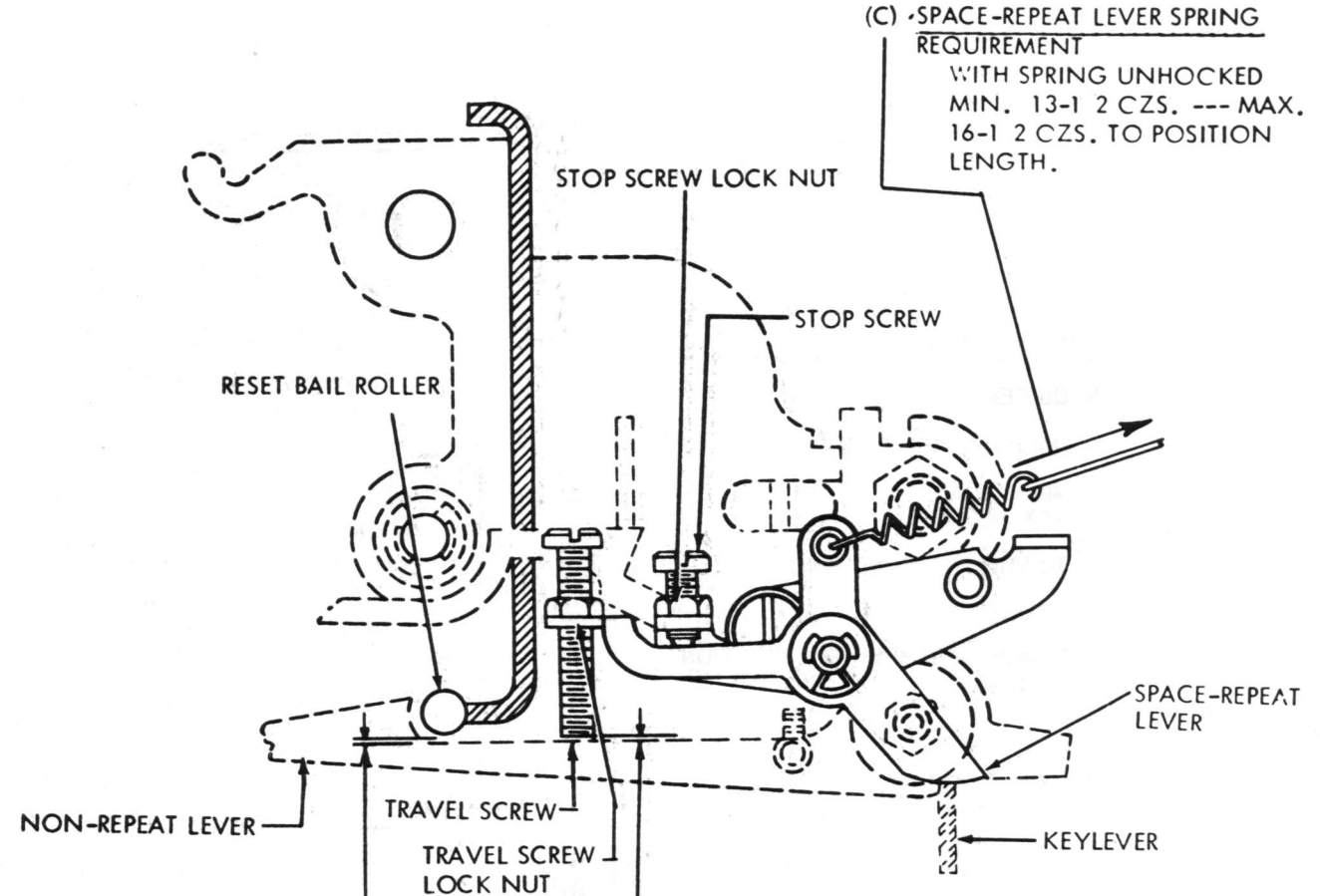

(A) TRAVEL SCREW REQUIREMENT  
 WITH SPACE BAR FULLY DEPRESSED:  
 MIN. 0.035 INCH --- MAX. 0.080 INCH  
 BETWEEN RESET BAIL ROLLER AND  
 NON-REPEAT LEVER.  
 TO ADJUST  
 WITH SPACE BAR FULLY DEPRESSED,  
 POSITION TRAVEL SCREW WITH ITS  
 LOCK NUT LOOSENED. RECHECK  
 CLEARANCE AFTER TIGHTENING  
 LOCK NUT.

(B) STOP REQUIREMENT  
 MIN. 0.002 INCH --- MAX. 0.020 INCH  
 BETWEEN TRAVEL SCREW AND NON-  
 REPEAT LEVER.  
 TO ADJUST  
 DEPRESS G KEYLEVER TO TRIP KEY-  
 BOARD CLUTCH. POSITION STOP  
 SCREW WITH ITS LOCK NUT  
 LOOSENED. RECHECK GAP AFTER  
 TIGHTENING LOCK NUT.

(C) SPACE-REPEAT LEVER SPRING REQUIREMENT  
 WITH SPRING UNHOCKED  
 MIN. 13-1 2 CZS. --- MAX.  
 16-1 2 CZS. TO POSITION  
 LENGTH.

(D) SPACE BAR  
 (1) REQUIREMENT (SINGLE SPACE)  
 NORMAL KEY TOP PRESSURE  
 TO TRANSMIT SINGLE SPACE  
 (2) REQUIREMENT (REPEAT SPACE)  
 SPACE BAR FULLY DEPRESSED AND  
 HELD DOWN TO EFFECT CONTINUOUS  
 SPACE TRANSMISSION.

NOTE: SPACE BAR TOUCH TO OBTAIN A  
 REPEAT IS AFFECTED BY THIS ADJUST-  
 MENT. TO GET A LIGHTER TOUCH,  
 ADJUST TO MAXIMUM LIMIT. TO  
 OBTAIN A HEAVIER TOUCH ADJUST  
 TO THE MINIMUM LIMIT.

3.10 Time Delay Mechanism

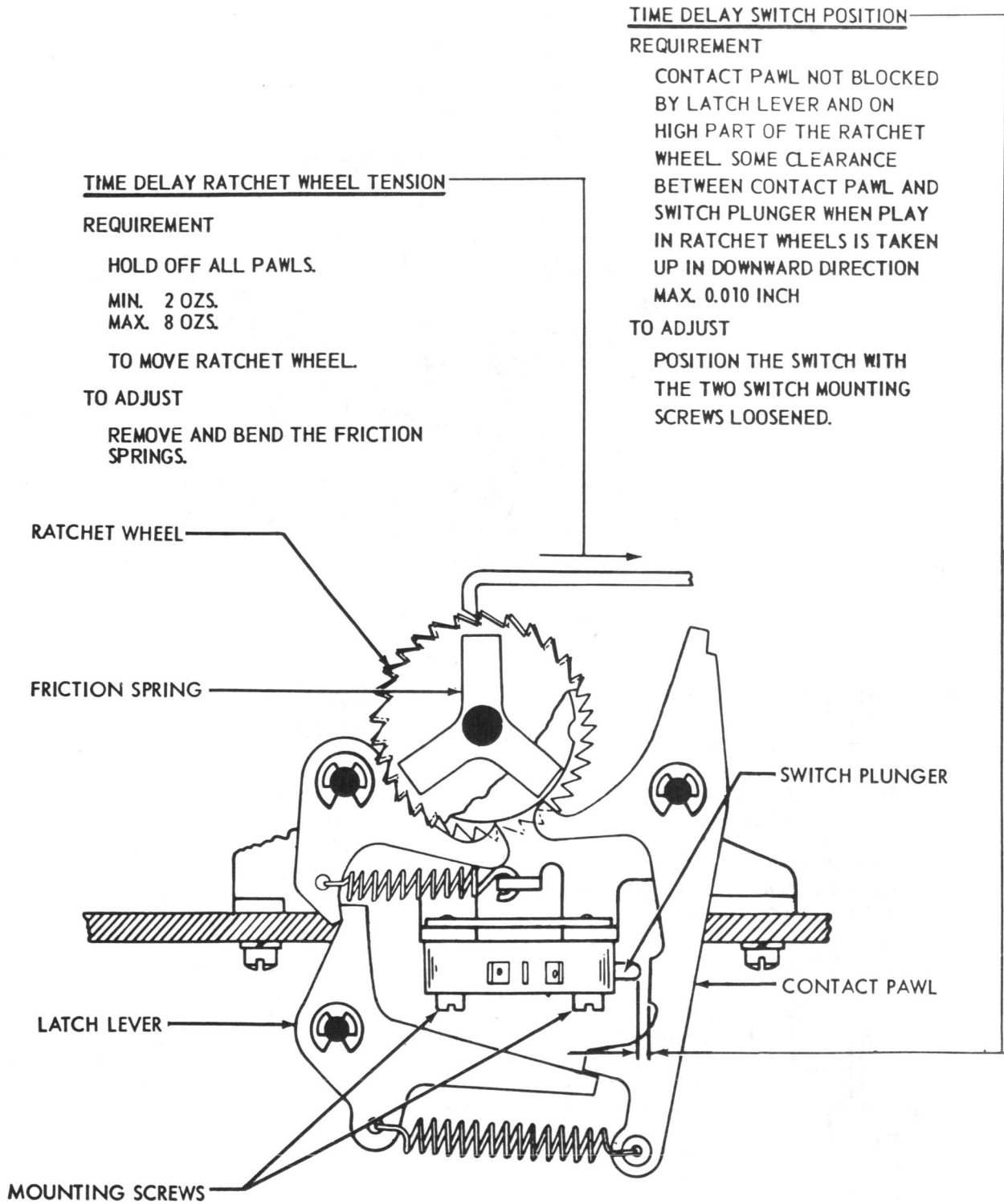

3.11 Time Delay Mechanism continued

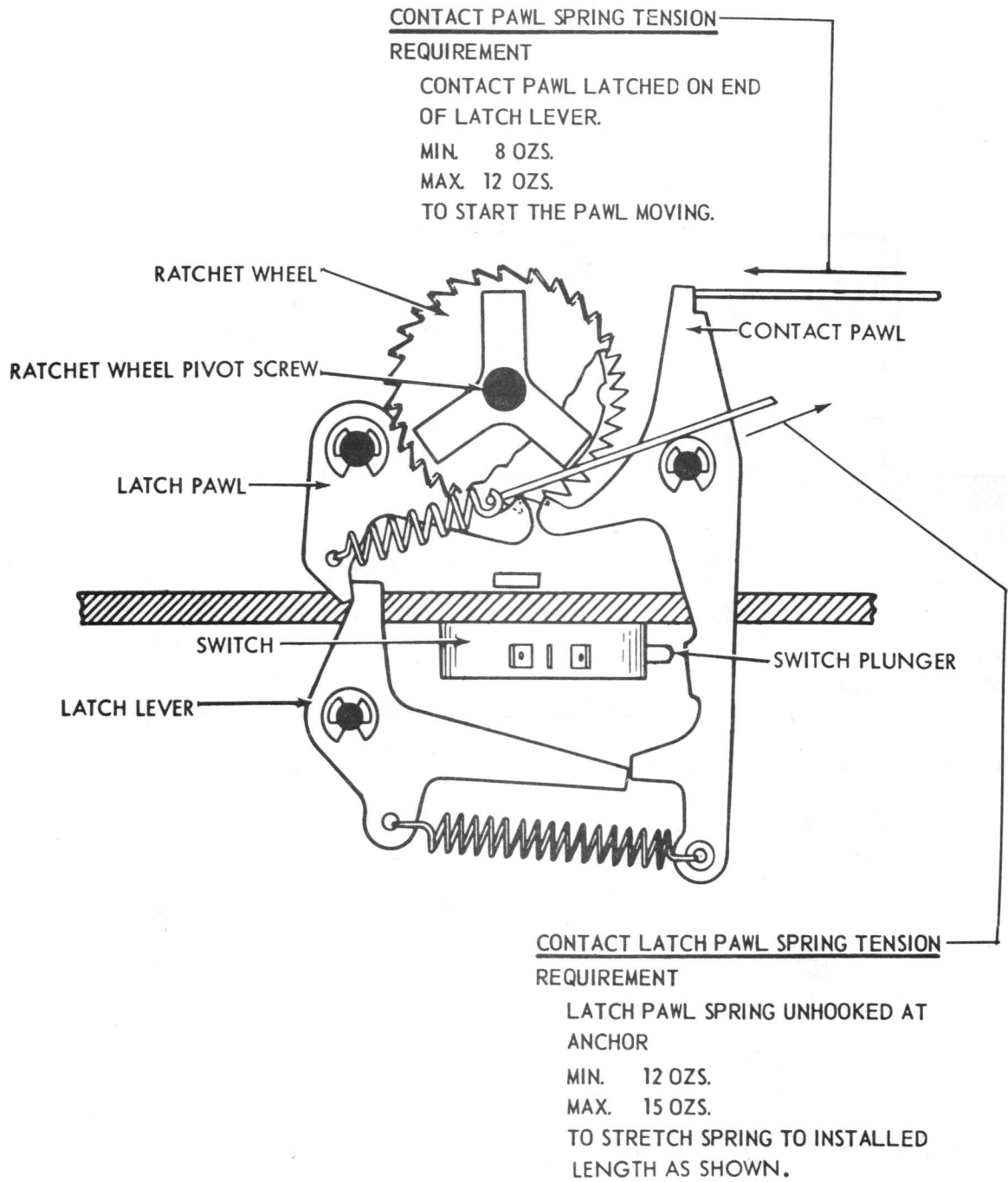

3.12 Time Delay Mechanism continued

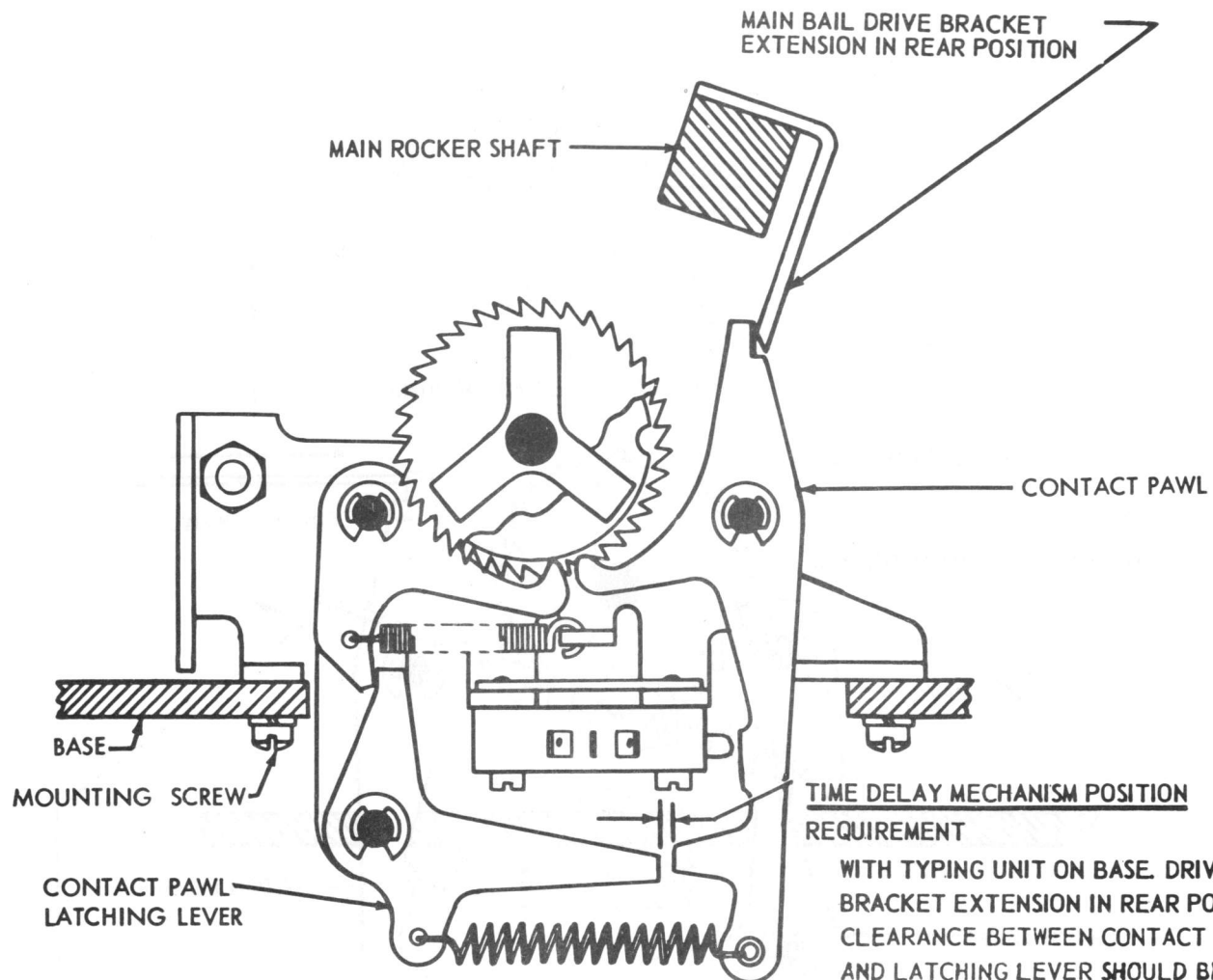

TO ADJUST

REMOVE THE TYPING UNIT FROM THE BASE. LOOSEN THE TIME DELAY MOUNTING SCREWS. ROTATE THE RATCHET WHEELS UNTIL THE LATCH PAWL DROPS INTO THE INDENTS IN THE TWO RATCHET WHEELS. LIFT THE ECCENTRIC FOLLOWER PAWL UPWARD. TAKE UP THE PLAY BY PRESSING THE RATCHET WHEELS BACKWARD. WITH THE ECCENTRIC FOLLOWER PAWL AT THE END OF ITS EXTREME FORWARD TRAVEL, POSITION THE MECHANISM SO THAT THE POINT OF THE LOWER BEVELED EDGE OF THE FOLLOWER PAWL RESTS ON THE PEAK OF THE FIRST RATCHET-WHEEL TOOTH FORWARD OF A VERTICAL CENTERLINE THROUGH THE RATCHET WHEEL OR OVER TRAVELS THE PEAK BY NOT MORE THAN 0.010 INCH. RECHECK MINIMUM CLEARANCE OF 0.020 INCH WITH TYPER ON KEYBOARD BASE. IF NECESSARY, REFINE ADJUSTMENT



## 3.13 Time Delay Mechanism continued

ECCENTRIC FOLLOWER PAWL SPRINGREQUIREMENT

ECCENTRIC FOLLOWER PAWL IN EXTREME FORWARD POSITION. 8 OZ. SCALE APPLIED TO PAWL NEAR RATCHET WHEEL AND PULLED UPWARD  
 UPWARD  
 MIN. 1-1/2 OZS.  
 MAX. 4 OZS.  
 TO START PAWL MOVING.

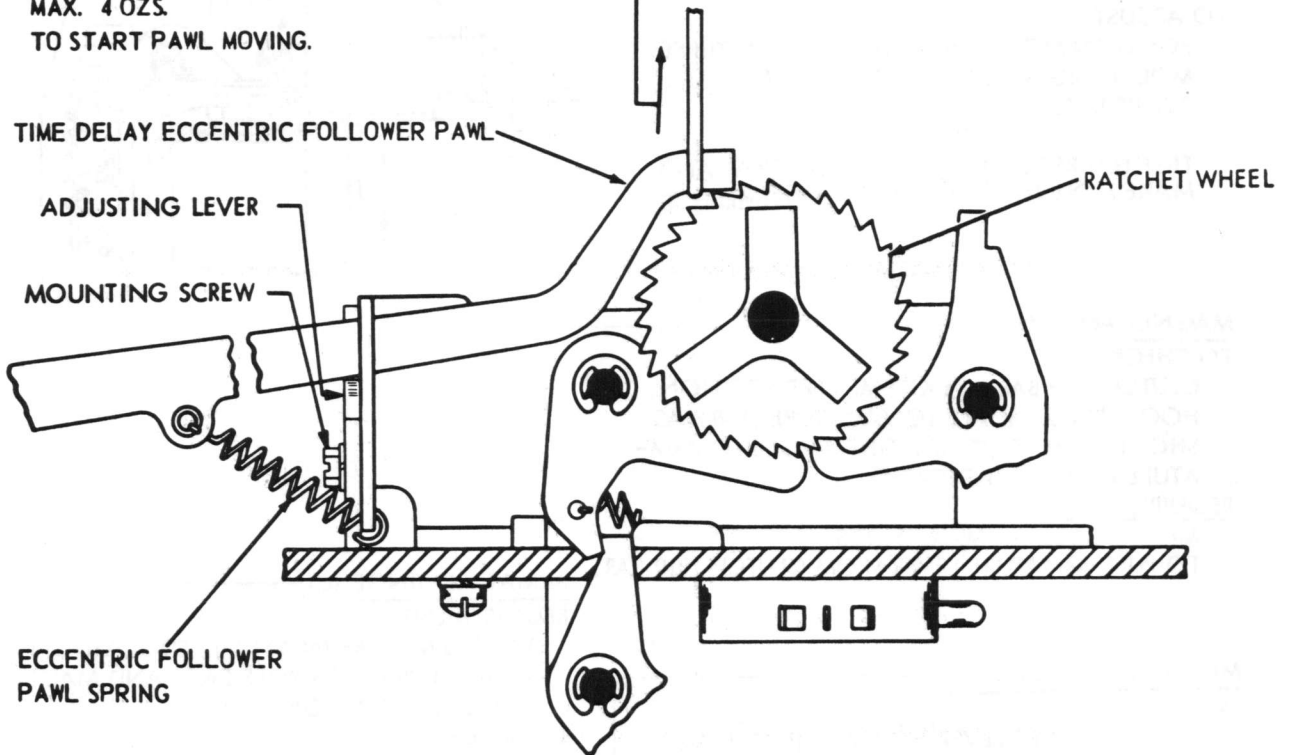
TIME DELAY DISABLING DEVICEREQUIREMENT

DISABLE THE TIME DELAY MECHANISM WHEN NOT REQUIRED.

TO ADJUST

LOOSEN THE ADJUSTING LEVER MOUNTING SCREW AND PRESS DOWNWARD ON THE LEVER TO RAISE ECCENTRIC FOLLOWER OUT OF ENGAGEMENT WITH ITS RATCHET WHEEL.

3.14 Synchronous Pulse Mechanism

MOUNTING BRACKET (A)

TO CHECK

WITH MAGNET NOT ATTRACTED AND CLUTCH TRIP BAR IN FURTHEST LEFT POSITION.

REQUIREMENT

MIN. 0.005 INCH --- MAX. 0.015 INCH BETWEEN CLUTCH TRIP BAR AND ARMATURE LEVER.

TO ADJUST

POSITION MOUNTING BRACKET WITH THREE MOUNTING SCREWS LOOSE BY MEANS OF PRY POINT.

NOTE

TIGHTEN REAR LEFT MOUNTING SCREW AND MAKE MOUNTING BRACKET ADJUSTMENT (B).

REAR LEFT MOUNTING SCREW

PRY POINT

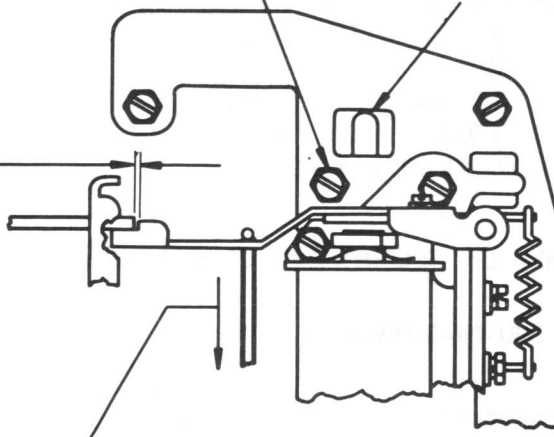

MAGNET ARMATURE (D)

TO CHECK

CLUTCH TRIP BAR IN EXTREME LEFT POSITION. HOOK 32 OZ. SCALE TO ARMATURE LEVER AS SHOWN. MEASURE AT RIGHT ANGLE TO ARMATURE LEVER AS INDICATED.

REQUIREMENT

MIN. 3 OZS. --- MAX. 5 OZS.

TO PULL ARMATURE LEVER FROM CLUTCH TRIP BAR.

ARMATURE HINGE (C)

REQUIREMENT

WITH ARMATURE IN ATTRACTED POSITION ARMATURE FLUSH WITH POLE FACE AND MAGNET BRACKET EXTENSION.

TO ADJUST

POSITION ARMATURE WITH HINGE BRACKET MOUNTING SCREW AND SPRING POST LOOSE.

MOUNTING BRACKET (B)

TO CHECK

WITH ARMATURE LEVER HELD AGAINST MAGNET POLE FACE AND CLUTCH TRIP BAR IN FURTHEST RIGHT POSITION.

REQUIREMENT

MIN. 0.005 INCH --- MAX. 0.015 INCH BETWEEN CLUTCH TRIP BAR AND ARMATURE LEVER.

TO ADJUST

WITH RIGHT REAR AND LEFT FRONT MOUNTING BRACKET SCREWS LOOSE POSITION MOUNTING BRACKET BY MEANS OF PRY POINT.

MOUNTING SCREWS

PRY POINT

CLUTCH TRIP BAR

ARMATURE LEVER

SPRING POST

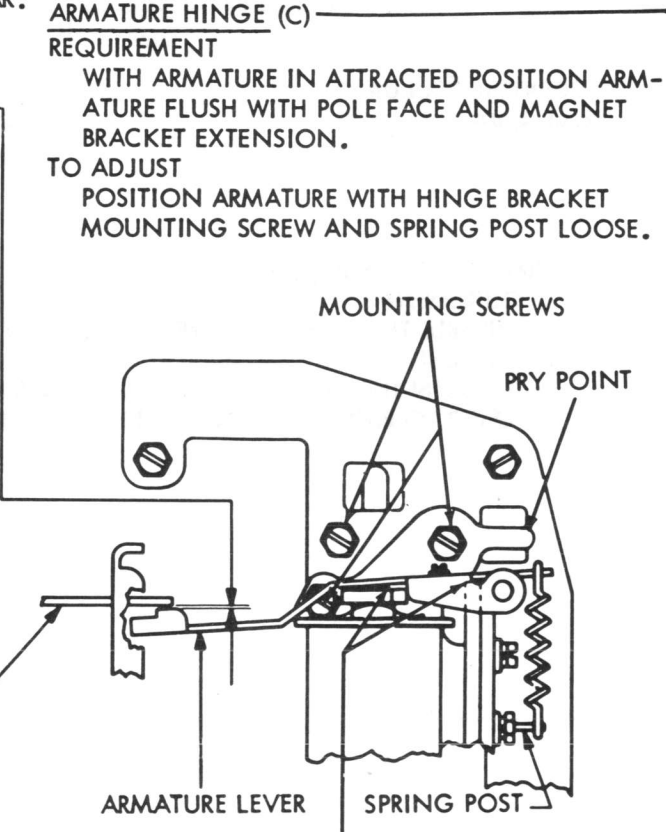

3.15 Synchronous Pulse Mechanism continued

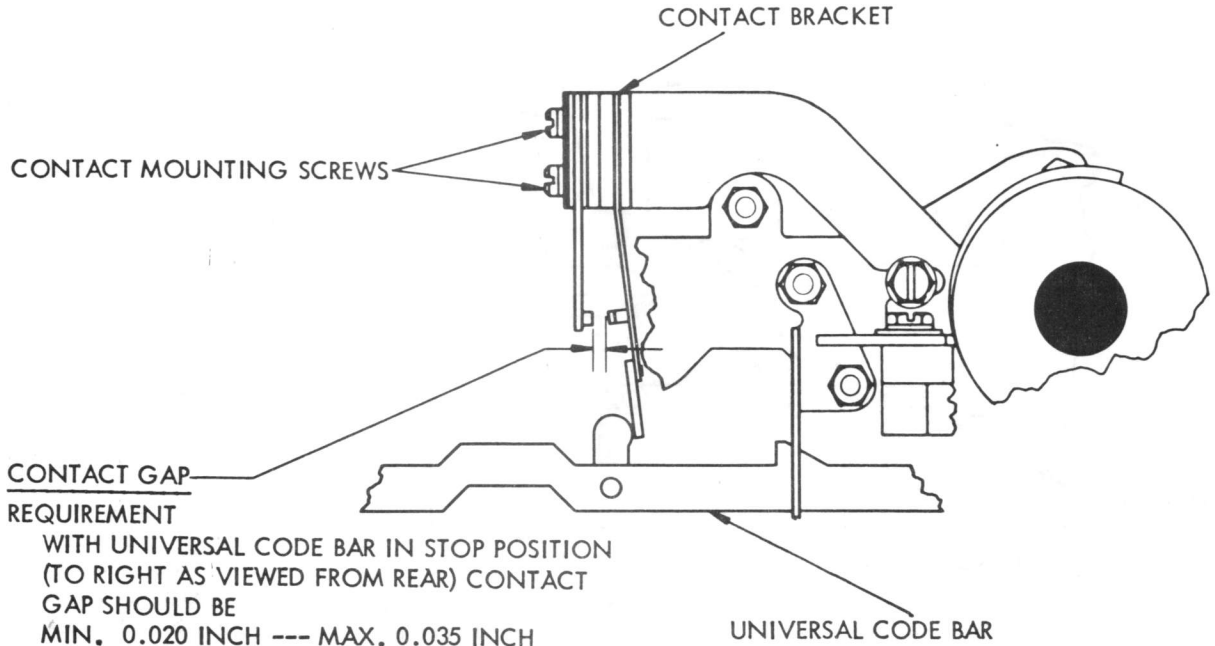

CONTACT GAP  
 REQUIREMENT  
 WITH UNIVERSAL CODE BAR IN STOP POSITION  
 (TO RIGHT AS VIEWED FROM REAR) CONTACT  
 GAP SHOULD BE  
 MIN. 0.020 INCH --- MAX. 0.035 INCH  
 TO ADJUST  
 POSITION CONTACT MOUNTING BRACKET  
 WITH MOUNTING SCREWS LOOSE.

UNIVERSAL CODE BAR CONTACT  
 REQUIREMENT  
 WITH UNIVERSAL CODE BAR IN OPERATED  
 POSITION (TO THE LEFT AS VIEWED FROM REAR)  
 MIN. 3-1/2 OZS. --- MAX. 4-1/2 OZS.  
 TO OPEN CONTACTS.  
 TO ADJUST  
 BEND CONTACT SWINGER.

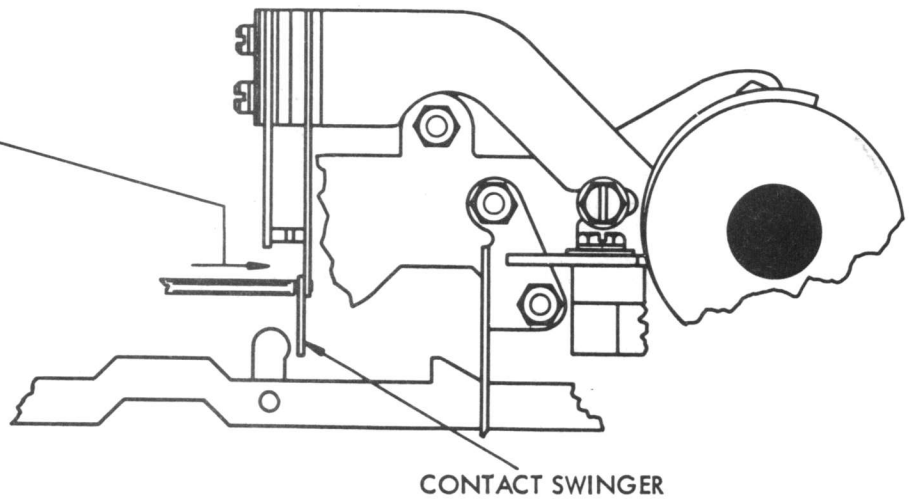

3.16 Synchronous Pulse Mechanism continued

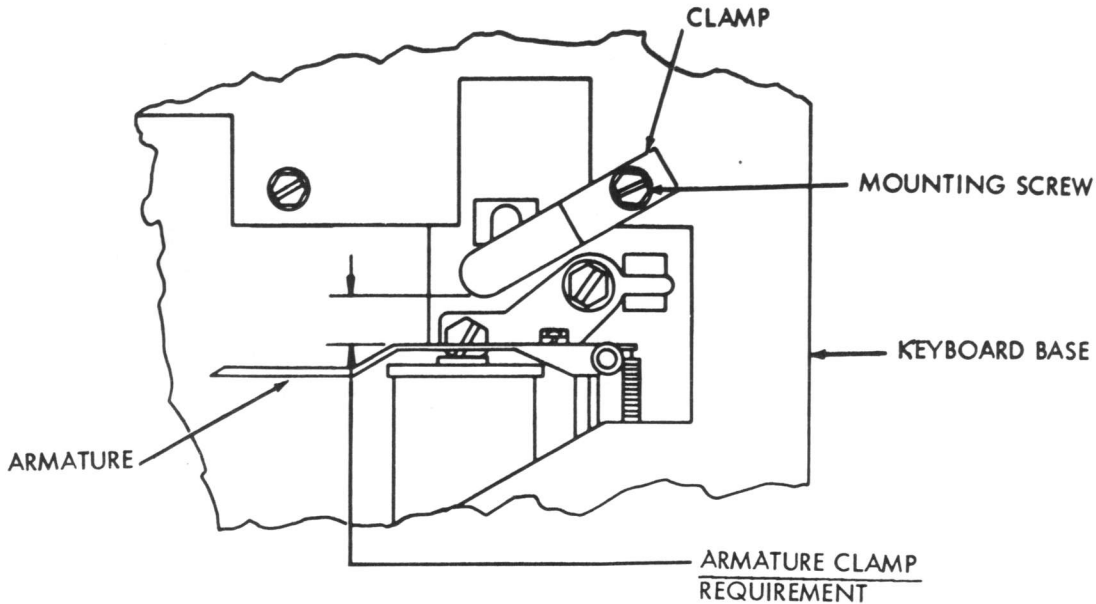

NOTE: TO MAKE KEYBOARD OPERABLE WITHOUT ELECTRICAL PULSE TO OPERATE STEPPING MAGNET LOOSEN CLAMP MOUNTING SCREW AND ROTATE CLAMP COUNTERCLOCKWISE TO HOLD THE ARMATURE IN THE OPERATING POSITION. MAINTAIN 0.005 INCH TO 0.015 INCH CLEARANCE BETWEEN CLUTCH TRIP BAR AND ARMATURE LEVER.

ARMATURE CLAMP REQUIREMENT  
WITH ARMATURE OPERATED, CLEARANCE BETWEEN ARMATURE CLAMP AND ARMATURE APPROX. 3/8 INCH  
TO ADJUST POSITION CLAMP WITH ITS MOUNTING SCREW LOOSENED.

3.17 Power Backspace Switch

POWER BACKSPACE SWITCH POSITION

NOTE

THIS IS NOT A ROUTINE ADJUSTMENT AND SHOULD BE CHECKED AND MADE ONLY IF TROUBLE IN ITS OPERATION IS ENCOUNTERED OR PARTS ARE DISASSEMBLED AND REPLACED.

- (1) REQUIREMENT  
WITH SWITCH OPERATING LEVER HELD PARALLEL TO THE TOP OF ITS MOUNTING BRACKET AND DEPRESSED TO LIMIT OF ITS TRAVEL, THE SWITCH SHALL BE OPERATED.
- (2) REQUIREMENT  
WITH SWITCH IN UNOPERATED CONDITION AND OPERATING LEVER HELD PARALLEL TO TOP OF ITS MOUNTING BRACKET, THERE SHOULD BE SOME CLEARANCE BETWEEN THE OPERATING LEVER AND TOP OF THE CURVED SLOT IN THE BRACKET.  
TO ADJUST  
POSITION SWITCH BRACKET WITH ITS MOUNTING  
SCREWS LOOSENED.

SWITCH OPERATING LEVER

BRACKET

BACKSPACE SWITCH

SWITCH KEYLEVER

SWITCH OPERATING LEVER

MOUNTING BRACKET

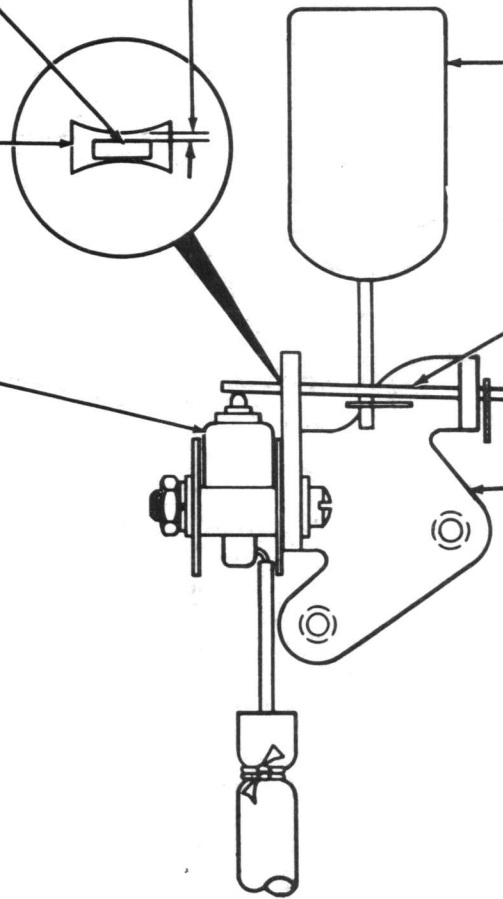

3.18 Remote Control Gear Shift Mechanism

GEAR SHIFT MECHANISM

REQUIREMENT

THE BACKLASH BETWEEN THE MOTOR PINION AND ITS DRIVEN GEAR AND BETWEEN THE TYPING UNIT DRIVEN GEAR AND ITS DRIVING GEAR SHOULD BE SOME --- MAX. 0.005 INCH

TO ADJUST

LOOSEN THE FOUR SCREWS WHICH MOUNT THE ASSEMBLY BRACKET TO BASE. LOOSEN THE NUT-PLATE MOUNTING SCREW AT FRONT OF ASSEMBLY BRACKET. LOOSEN LOCK NUTS ON ADJUSTING BUSHINGS. POSITION GEAR SHIFT BRACKET ASSEMBLY FRONT TO REAR. RAISE OR LOWER REAR OF ASSEMBLY BY ROTATING ADJUSTING BUSHING NEAREST THE MOTOR. POSITION OTHER BUSHING AGAINST BASE PLATE AND TIGHTEN ALL SCREWS AND LOCK NUT.

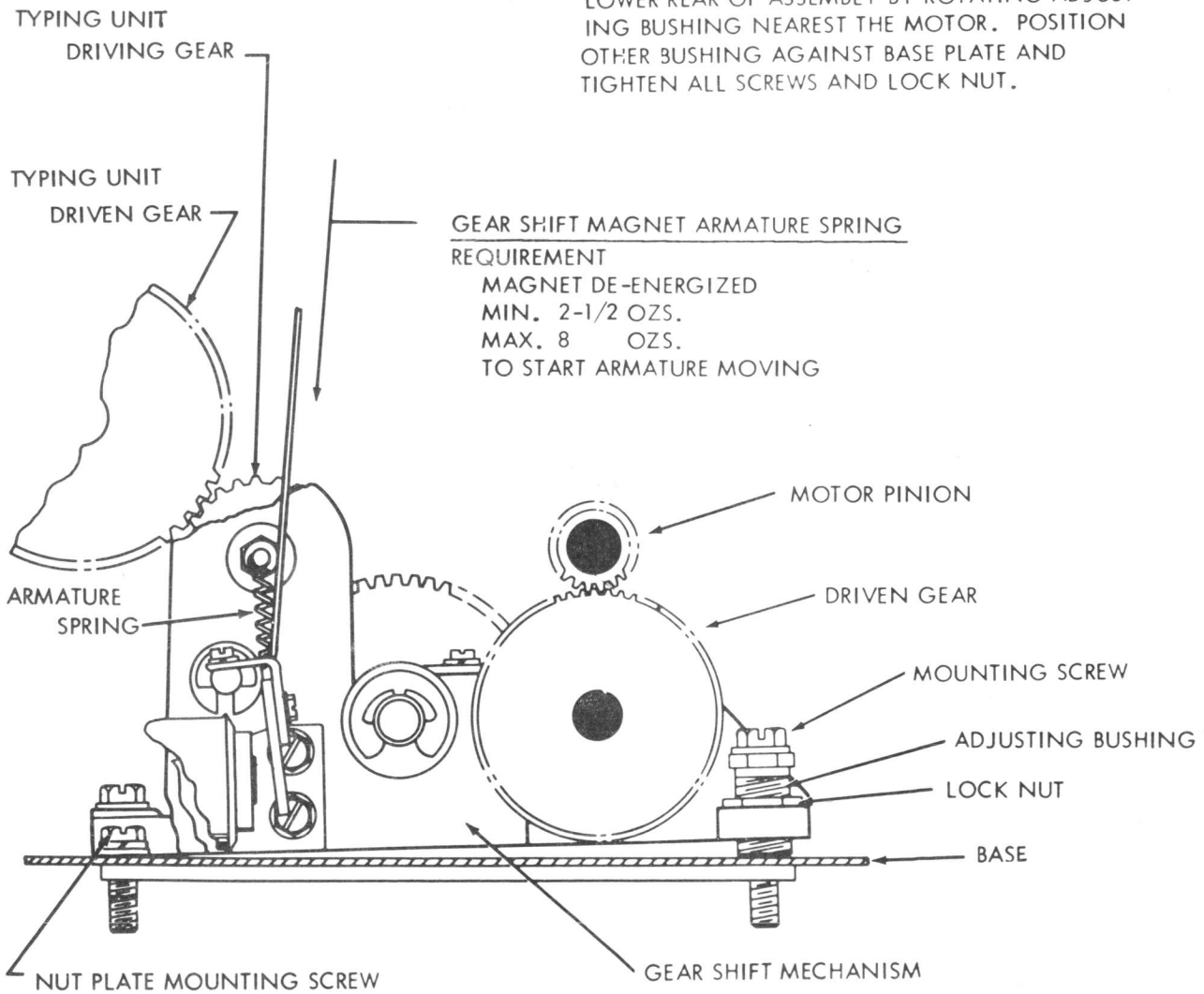

3.19 Remote Control Gear Shift Mechanism continued

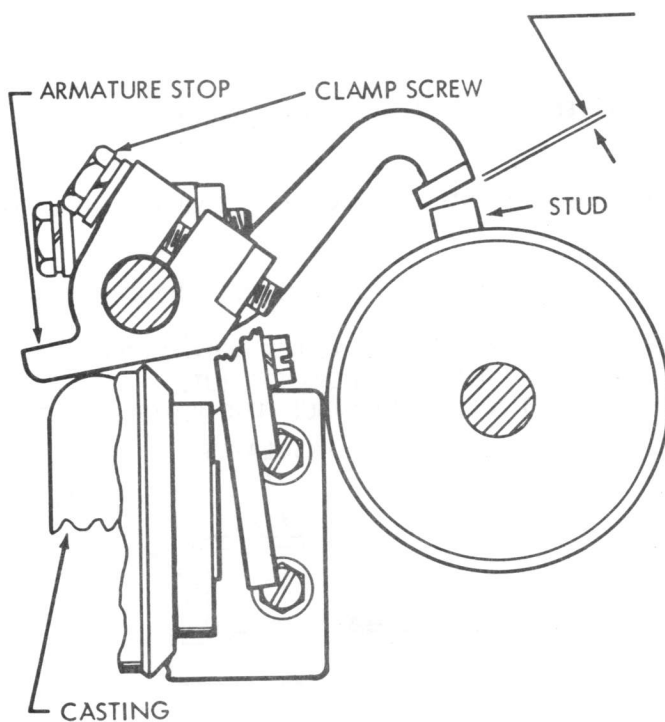

ARMATURE STOP

REQUIREMENT

WITH ARMATURE IN ITS OPEN POSITION AND THE ARMATURE STOP AGAINST THE CASTING, CLEARANCE BETWEEN GEAR SHIFT LEVER AND STUD ON SLEEVE  
 MIN. 0.010 INCH  
 MAX. 0.020 INCH

TO ADJUST

HOLD GEAR SHIFT LEVER IN POSITION AND POSITION ARMATURE STOP WITH ITS CLAMP SCREW LOOSENED UNTIL REQUIREMENT IS MET.

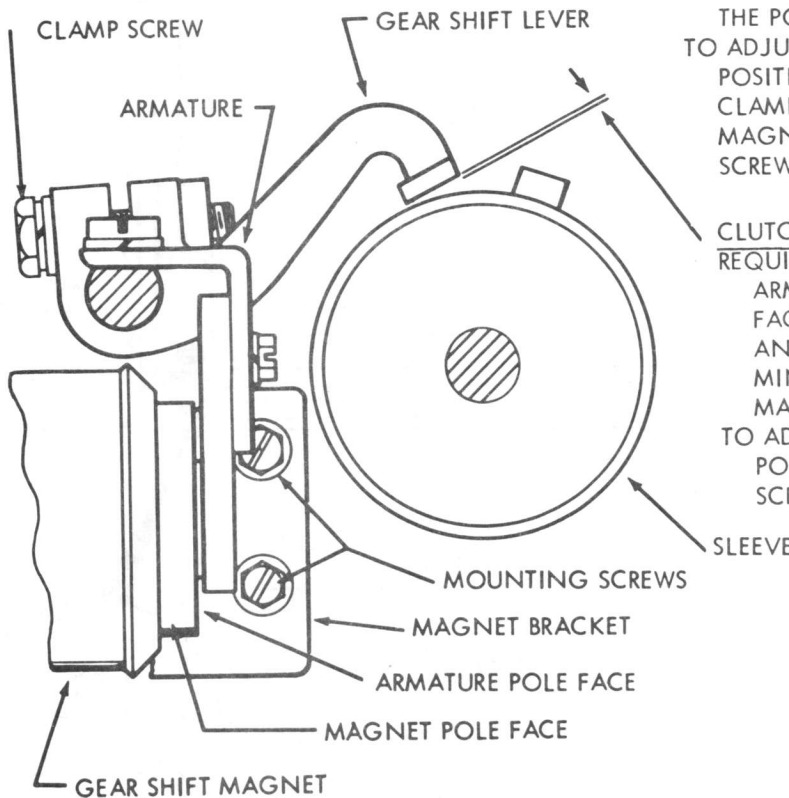

GEAR SHIFT MAGNET

REQUIREMENT

THE POLE FACE OF THE ARMATURE SHOULD MEET THE POLE FACE OF THE MAGNET SQUARELY  
TO ADJUST

POSITION ARMATURE WITH GEAR SHIFT LEVER CLAMP SCREW LOOSENED AND POSITION MAGNET BRACKET WITH ITS MOUNTING SCREWS LOOSENED.

CLUTCH STOP LEVER

REQUIREMENT

ARMATURE RESTING AGAINST MAGNET POLE FACE, CLEARANCE BETWEEN GEAR SHIFT LEVER AND THE SLEEVE  
 MIN. 0.002 INCH  
 MAX. 0.010 INCH

TO ADJUST

POSITION GEAR SHIFT LEVER WITH ITS CLAMP SCREW LOOSENED.



3.20 Perforator Motor

PERFORATOR MOTOR PINION AND DRIVEN GEAR MESH

REQUIREMENT

MIN. 0.004 INCH

MAX. 0.008 INCH

BAGKLASH BETWEEN MOTOR PINION AND DRIVEN GEAR AT POINT OF MINIMUM BACKLASH.

TO CHECK

- (1) LOOSEN THE FOUR MOTOR MOUNTING SCREWS.
- (2) LOOSEN THE TWO NUTS WHICH LOCK THE ADJUSTING BUSHINGS AT THE RIGHT END OF THE MOTOR (REAR VIEW)

TO ADJUST

- (1) BACK OFF A FEW TURNS ON THE REAR ADJUSTING BUSHING TO PROVIDE ENOUGH CLEARANCE TO MAKE THE ADJUSTMENT.
- (2) BY MEANS OF THE FRONT ADJUSTING BUSHING, ADJUST THE MOTOR HEIGHT TO MEET REQUIREMENT AT THE PINION AND DRIVEN GEARS. TIGHTEN THE LOCK NUT.
- (3) TURN THE REAR ADJUSTING BUSHING UNTIL IT TOUCHES THE MOUNTING PLATE. TIGHTEN THE LOCK NUT.

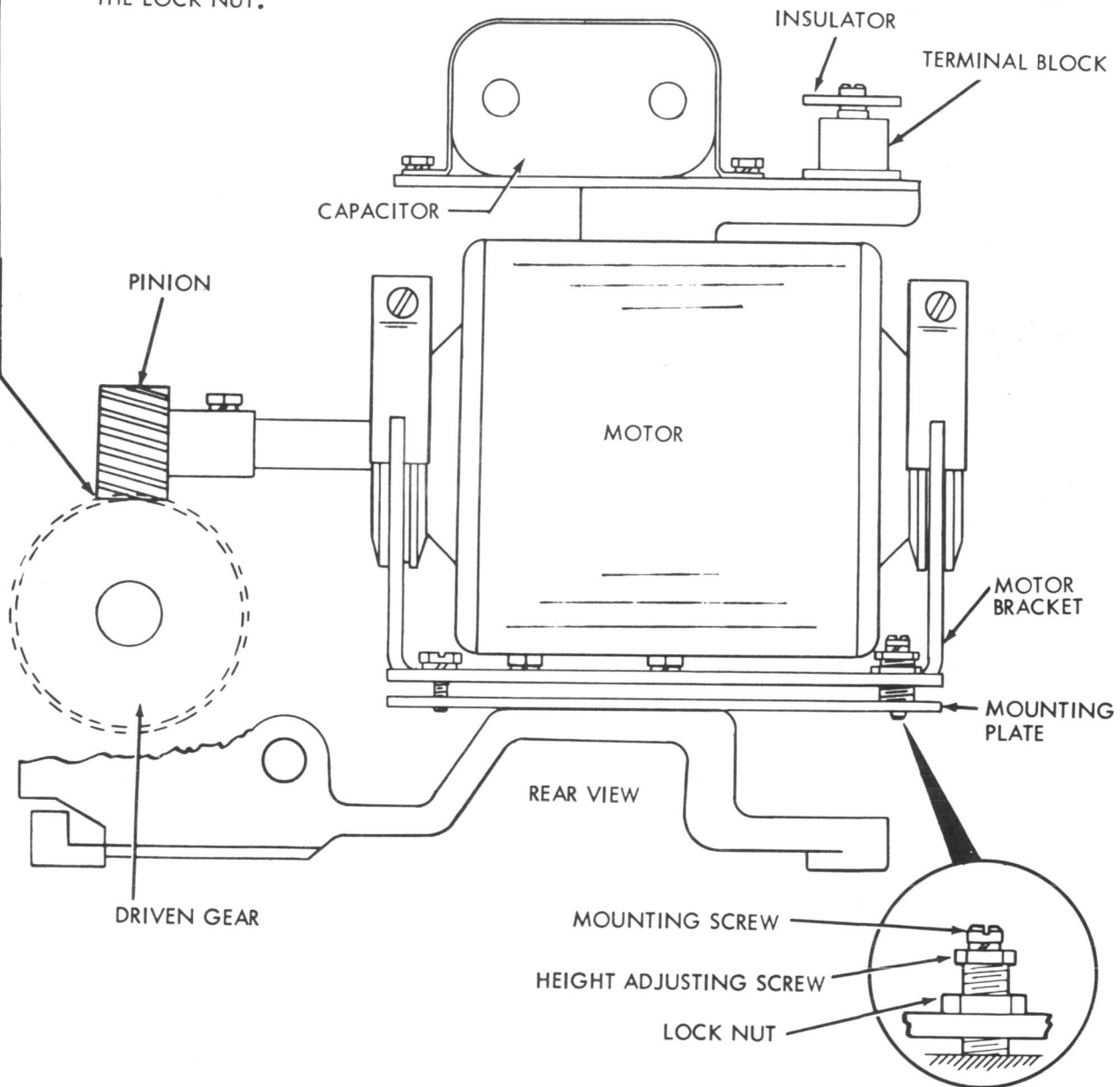

3.21 Universal Keyboard Switch

(A) KEYBOARD UNIVERSAL SWITCH  
PRELIMINARY  
REQUIREMENT

CENTERLINE OF INSULATED PORTION OF UNIVERSAL SWITCH ASSEMBLY SHOULD ALIGN WITH CENTERLINE OF CODE BAR LEVER.

TO ADJUST POSITION UNIVERSAL SWITCH ASSEMBLY Laterally ON RETAINER BAR WITH ITS MOUNTING SCREW LOOSENED.

BRACKET MOUNTING SCREW

RETAINER BAR BRACKET

RETAINER BAR

FRONT VIEW

BAR MOUNTING SCREW

CODE BAR LEVER

SWITCH ASSEMBLY

ASSEMBLY MOUNTING SCREW

(B) KEYBOARD UNIVERSAL SWITCH - HORIZONTAL  
REQUIREMENT

CENTERLINE OF INSULATED PORTION OF UNIVERSAL SWITCH ASSEMBLY SHOULD ALIGN WITH CENTERLINE OF LOWERMOST PORTION OF CODE BAR LEVER.

TO ADJUST POSITION RETAINER BAR FORWARD OR REARWARD ON ITS BRACKETS WITH ITS MOUNTING SCREWS LOOSENED.

CODE BAR LEVER

(C) KEYBOARD UNIVERSAL SWITCH - VERTICAL  
REQUIREMENT

1. CLEARANCE BETWEEN CENTER AND LOWER CONTACT POINTS SHOULD BE MIN. 0.015 INCH --- MAX. 0.025 INCH

TO CHECK

PULL CONTACT FUNCTION LEVER DOWN AGAINST CODE BAR BASKET AT REAR OF BASKET AND FRONT OF CONTACT LEVER TOUCHING CENTER OF CONTACT INSULATOR

TO ADJUST

BEND UPPER CONTACT SPRING

2. CLEARANCE BETWEEN CENTER AND LOWER CONTACT POINTS SHOULD BE AT LEAST 0.010 INCH

TO CHECK

DEPRESS CONTACT OPERATING KEY WITH 16 OZS. PRESSURE.

3. CENTER AND LOWER CONTACTS SHOULD CLOSE WITH SOME OVER-TRAVEL

TO CHECK

FULLY DEPRESS CONTACT OPERATING KEY

TO ADJUST

POSITION COMPLETE ASSEMBLY WITH RIGHT AND LEFT BRACKET MOUNTING SCREWS LOOSENED.

MOUNTING SCREWS

BRACKET

RETAINER BAR

SWITCH ASSEMBLY

FUNCTION LEVER

LEFT VIEW

SWITCH ASSEMBLY

3.22 Answer-Back Mechanism

NOTE 1: ADJUSTMENTS ON THIS PAGE SHOULD BE MADE WITH THE ANSWER-BACK MECHANISM REMOVED FROM THE KEYBOARD.

NOTE 2: FOR "HERE IS" KEYLEVER SWITCH REQUIREMENTS SEE UNIVERSAL KEYBOARD SWITCH ADJUSTMENTS, PAGE 47.

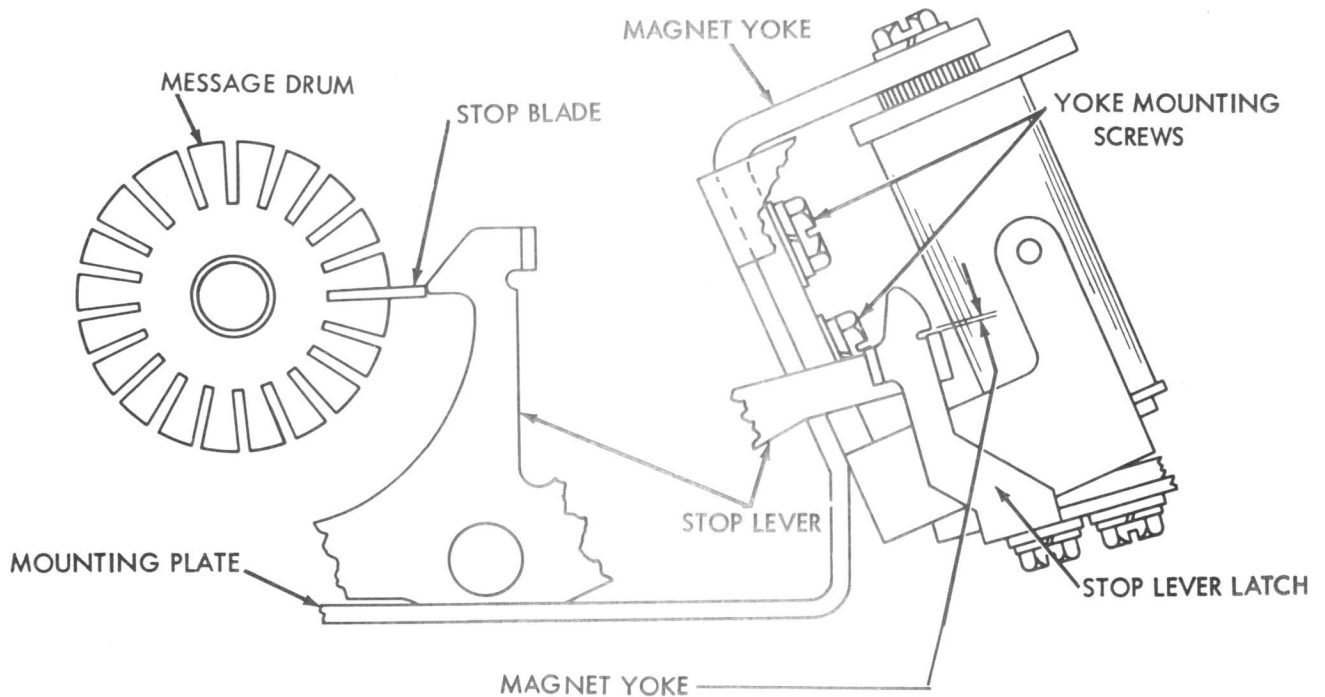

MAGNET YOKE  
REQUIREMENT

CLEARANCE BETWEEN LATCHING SURFACES OF  
STOP LEVER EXTENSION AND STOP LEVER  
LATCH SHOULD BE  
MIN. 0.005 INCH  
MAX. 0.015 INCH

TO CHECK

HOLD TIP OF STOP LEVER AGAINST STOP BLADE.

TO ADJUST

POSITION MAGNET YOKE WITH ITS TWO  
MOUNTING SCREWS LOOSENED.

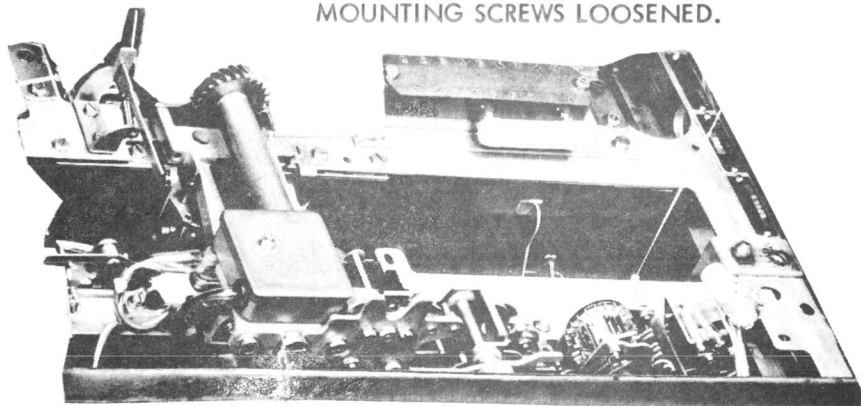
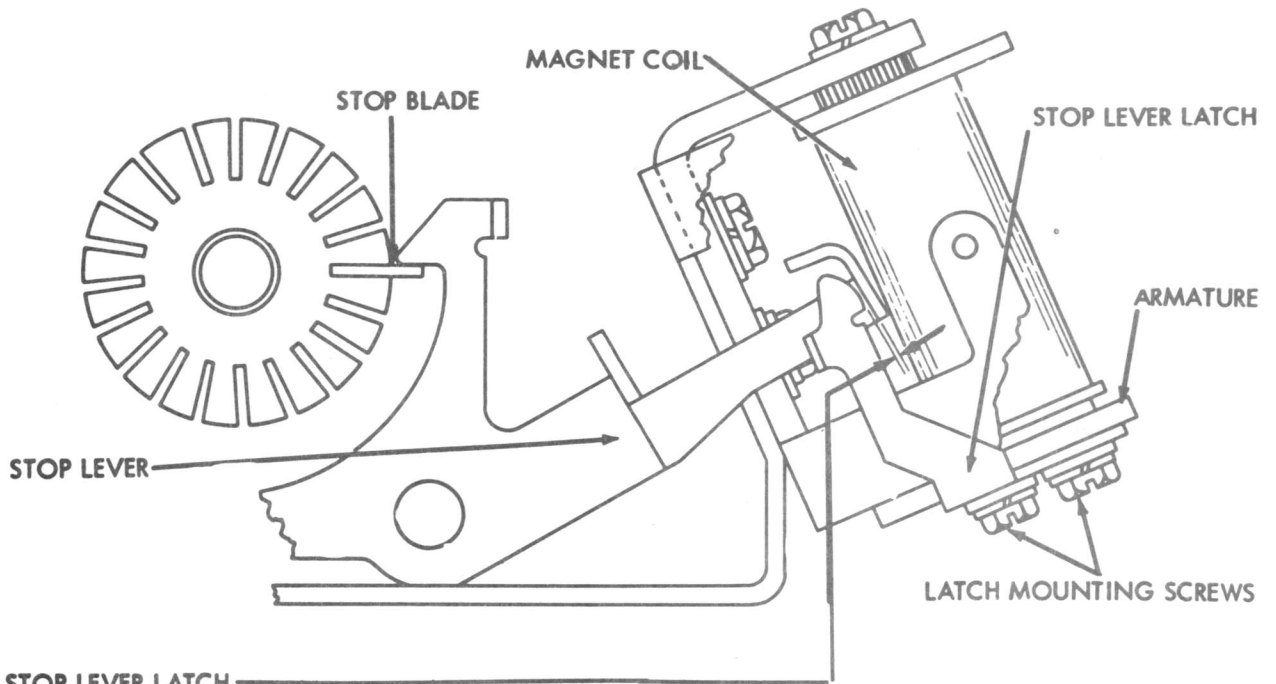

Figure 2-28 — Answer-Back Mechanism

## 3.23 Answer-Back Mechanism continued

**STOP LEVER LATCH****(1) REQUIREMENT**

CLEARANCE BETWEEN STOP LEVER AND STOP LEVER LATCH SHOULD BE  
 MIN. 0.002 INCH  
 MAX. 0.007 INCH

**TO CHECK**

HOLD ARMATURE AGAINST THE MAGNET CORE AND THE STOP LEVER IN ITS MAXIMUM COUNTER-CLOCKWISE POSITION.

**(2) REQUIREMENT**

CLEARANCE BETWEEN STOP LEVER AND STOP LEVER LATCH THROUGHOUT A COMPLETE TRAVEL OF THE STOP LEVER  
 MIN. 0.002 INCH

**TO CHECK**

HOLD ARMATURE AGAINST MAGNET CORE.

**TO ADJUST**

POSITION STOP LEVER LATCH WITH ITS TWO MOUNTING SCREWS LOOSENED.

3.24 Answer-Back Mechanism continued

NOTE: TO FACILITATE MAKING THIS ADJUSTMENT, REMOVE MESSAGE DRUM AND DRIVE PLATE ASSEMBLY FROM MECHANISM.

(B) SENSING LEVER SPRINGS

REQUIREMENT

WITH THE SIGNAL GENERATOR CLUTCH IN STOP POSITION AND THE MESSAGE DRUM REMOVED IT SHOULD REQUIRE MIN. 1/4 OUNCE MAX. 1-1/4 OUNCES TO START EACH SENSING LEVER MOVING.

SENSING LEVERS RESTING ON MOUNTING PLATE

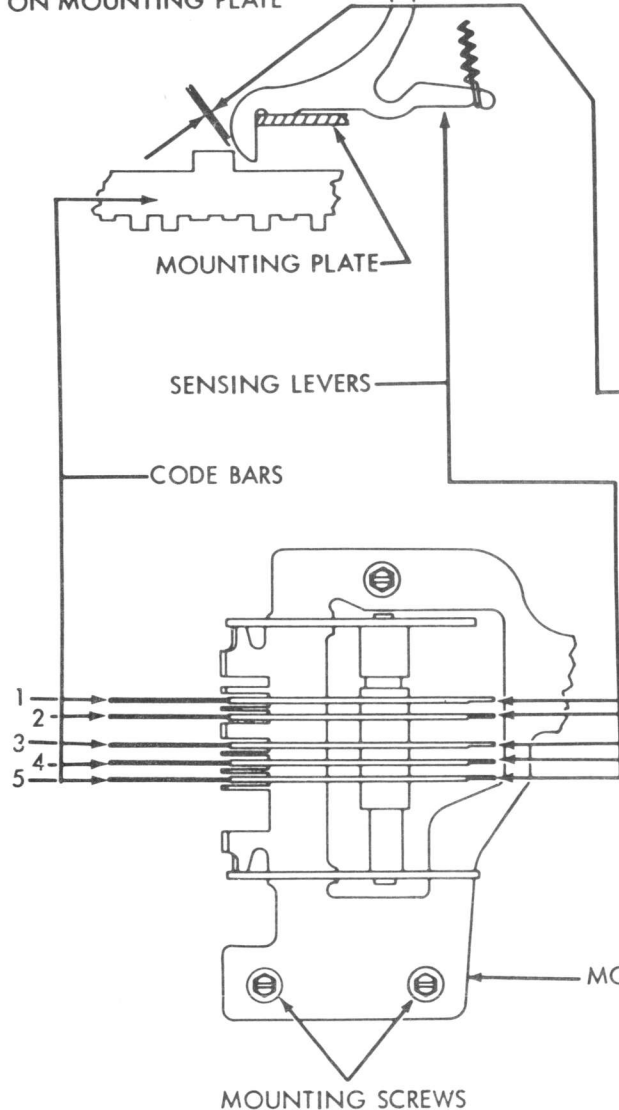

(C) DETENT LEVER SPRING

REQUIREMENT

WITH THE SIGNAL GENERATOR CLUTCH IN STOP POSITION AND THE MESSAGE DRUM REMOVED, IT SHOULD REQUIRE MIN. 22 OUNCES MAX. 26 OUNCES TO START THE DETENT LEVER MOVING.

DETENT LEVER RESTING ON MOUNTING PLATE

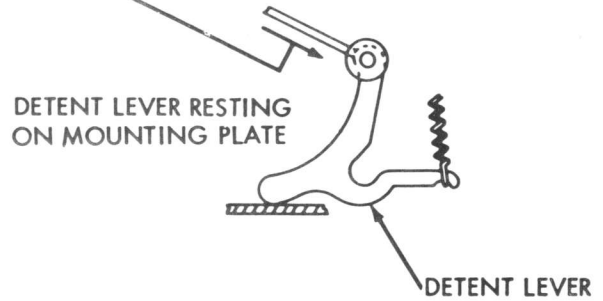

(A) CHARACTER GENERATOR MOUNTING PLATE

(1) REQUIREMENT

SENSING LEVERS SHOULD BE CENTERED ON THE FULL WIDTH OF THEIR ASSOCIATED CODE BAR.

(2) REQUIREMENT

CLEARANCE BETWEEN SHOULDERS OF CODE BARS #1 AND #5 AND THEIR ASSOCIATED SENSING LEVERS SHOULD BE MIN. 0.002 INCH MAX. 0.012 INCH

TO ADJUST

POSITION THE MOUNTING PLATE WITH THE THREE MOUNTING SCREWS LOOSENED.

## 3.25 Answer-Back Mechanism continued

PERFORM THIS ADJUSTMENT BEFORE FINAL INSTALLATION OF MESSAGE DRUM AND DRIVE PLATE ASSEMBLY.

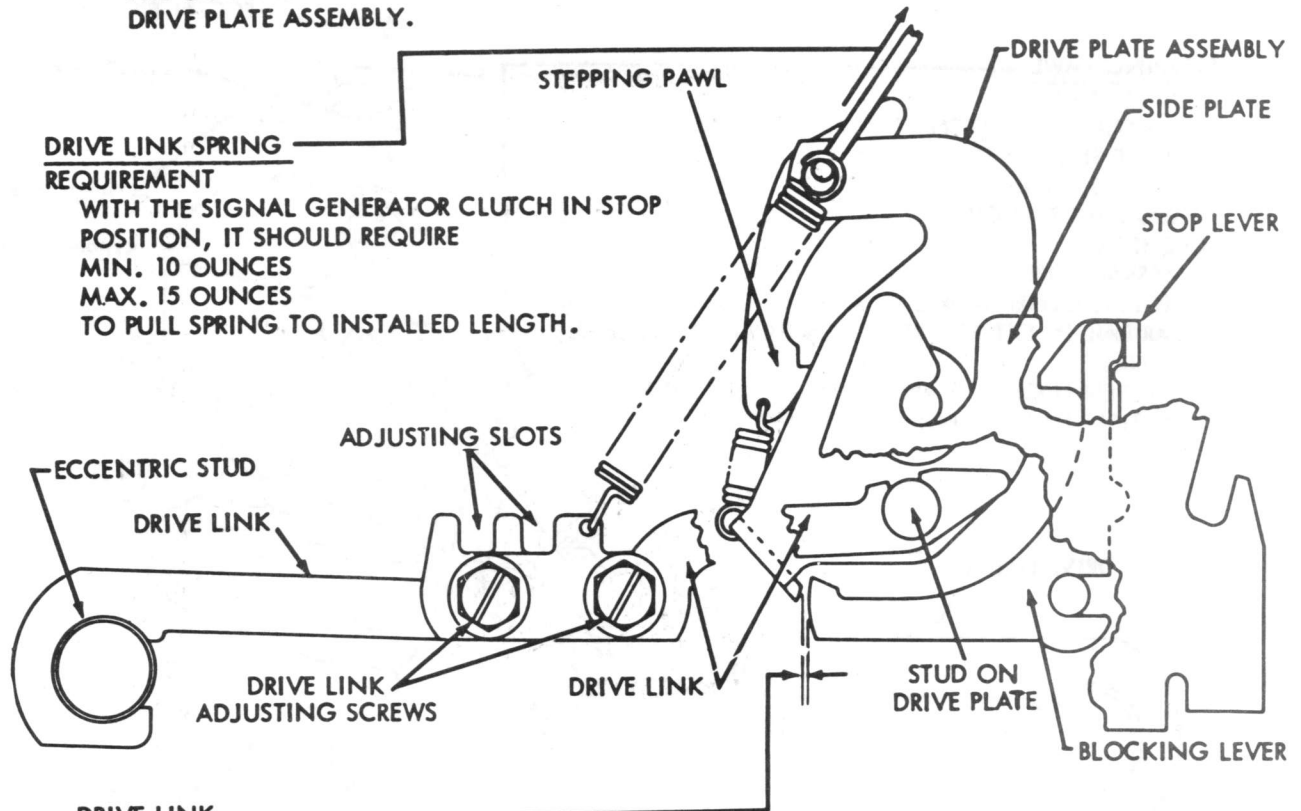

**DRIVE LINK SPRING  
REQUIREMENT**

WITH THE SIGNAL GENERATOR CLUTCH IN STOP POSITION, IT SHOULD REQUIRE  
MIN. 10 OUNCES  
MAX. 15 OUNCES  
TO PULL SPRING TO INSTALLED LENGTH.

**DRIVE LINK  
REQUIREMENT**

CLEARANCE BETWEEN DRIVE PLATE EXTENSION AND BLOCKING LEVER SHOULD BE  
MIN. 0.002 INCH  
MAX. 0.007 INCH

**TO CHECK**

SIGNAL GENERATOR CAM ECCENTRIC AND ARM HOLDING CODE BAR BAIL IN EXTREME RESET POSITION TO THE LEFT.

**TO ADJUST**

LOOSEN THE TWO ADJUSTING SCREWS AND POSITION THE TWO DRIVE LINKS BY MEANS OF THE ADJUSTING SLOTS.

NOTE: THE STANDARD KEYBOARD ADJUSTMENTS LISTED BELOW SHOULD BE CHECKED DURING INSTALLATION OF THE ANSWER-BACK MECHANISM.

- A. CODE BAR AND CODE LEVER CLEARANCE, PAGE 4.
- B. CODE BAR BAIL, PAGE 11.
- C. CODE BAR BAIL AND NON-REPEAT LEVER CLEARANCE, PAGE 11.
- D. UNIVERSAL BAIL LATCH LEVER, PAGE 13.
- E. UNIVERSAL BAIL EXTENSION, PAGE 13.

3.26 Answer-Back Mechanism continued

THE FOLLOWING FINAL ADJUSTMENTS FOR THE ANSWER-BACK MECHANISM SHOULD BE MADE AFTER INSTALLATION OF THE MECHANISM ON THE KEYBOARD.

**STEPPING PAWL**

**REQUIREMENT**

CLEARANCE BETWEEN STEPPING PAWL AND ANY CODE BLADE SHOULD BE  
MIN. 0.018 INCH  
MAX. 0.030 INCH

**TO CHECK**

MESSAGE DRUM IN FULLY DETENTED POSITION.  
SIGNAL GENERATOR CAM AND ARM HOLDING CODE  
BAR BAIL IN EXTREME RESET POSITION TO THE LEFT.

**TO ADJUST**

LOOSEN LOCK NUT AND POSITION ECCENTRIC STUD  
SO THAT ITS HIGH POINT IS TOWARD THE TOP.

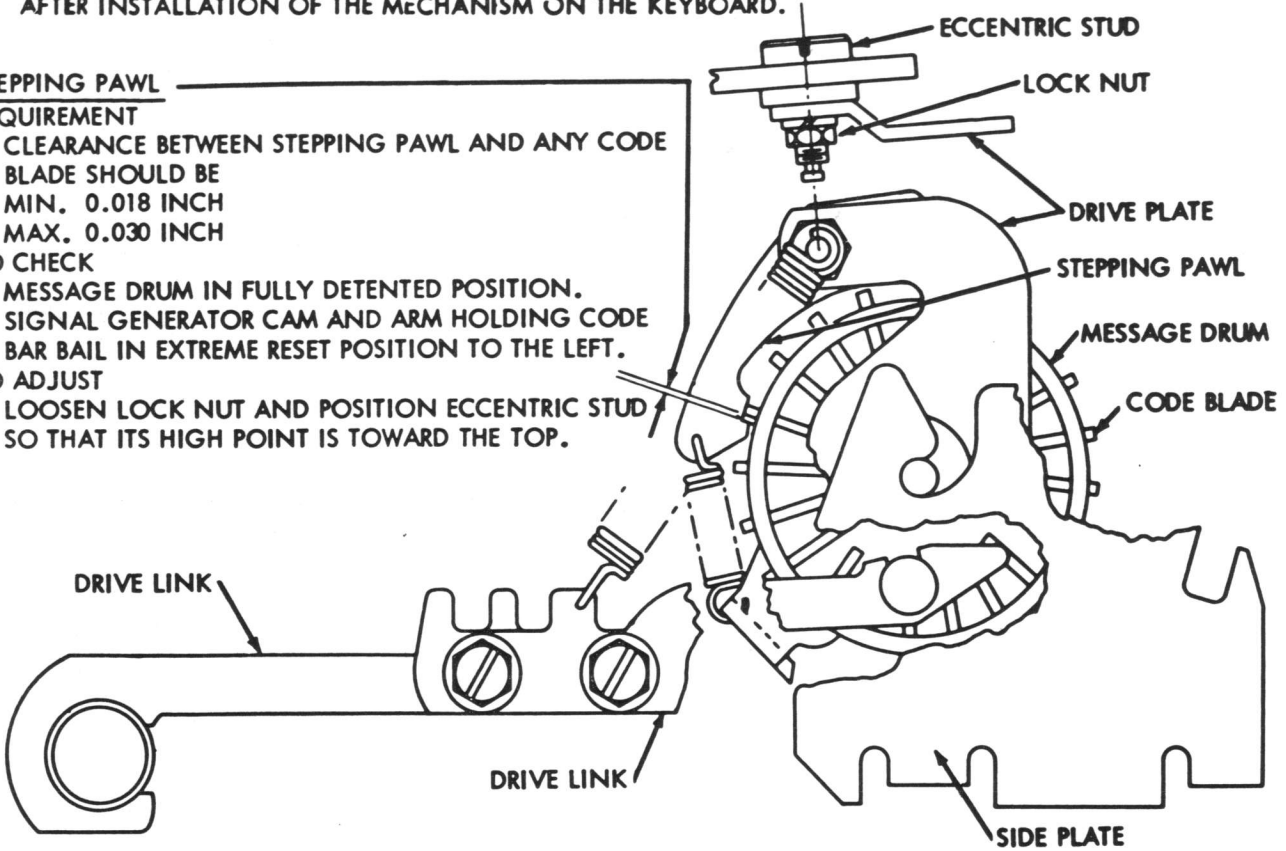



## 3.27 Answer-Back Mechanism continued

STEPPING PAWL SPRINGREQUIREMENT

WITH SIGNAL GENERATOR CLUTCH IN STOP POSITION.  
 MIN. 2-1/2 OUNCES  
 MAX. 3-1/2 OUNCES  
 TO START PAWL MOVING.

LATCH OPERATING LEVER SPRINGREQUIREMENT

WITH SIGNAL GENERATOR CLUTCH IN STOP POSITION  
 MIN. 5 OUNCES  
 MAX. 6 OUNCES  
 TO START LEVER MOVING.

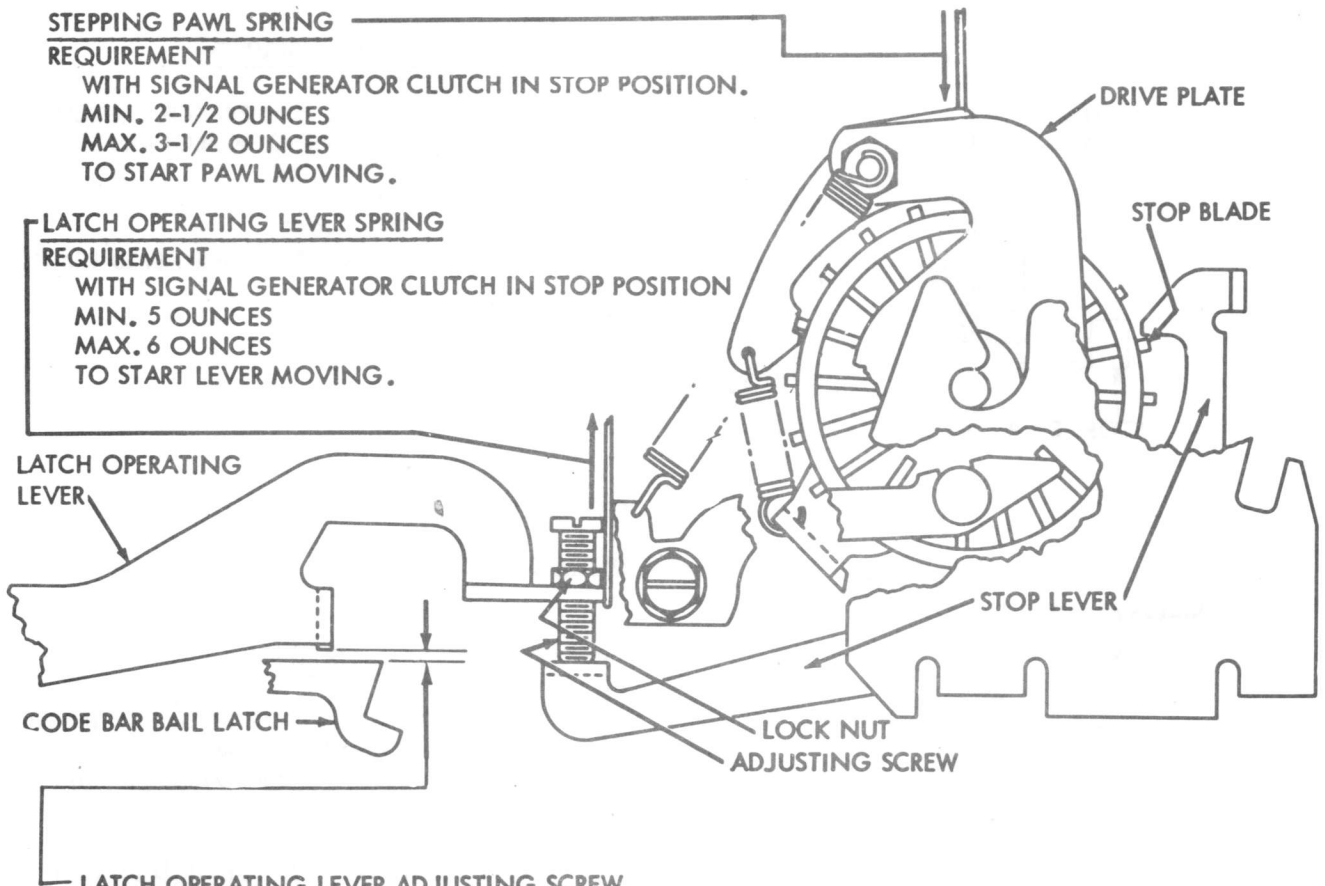
LATCH OPERATING LEVER ADJUSTING SCREWREQUIREMENT

CLEARANCE BETWEEN EXTENSION ON LATCH OPERATING LEVER AND CODE BAR BAIL LATCH  
 SHOULD BE  
 MIN. 0.005 INCH  
 MAX. 0.015 INCH

TO CHECK

SIGNAL GENERATOR CLUTCH FULLY DISENGAGED. STOP LEVER LATCHED ON MAGNET ARM-  
 ATURE LATCH.

TO ADJUST

WITH LOCK NUT LOOSENED, POSITION LATCH OPERATING ADJUSTING SCREW.

3.28 Answer-Back Mechanism continued

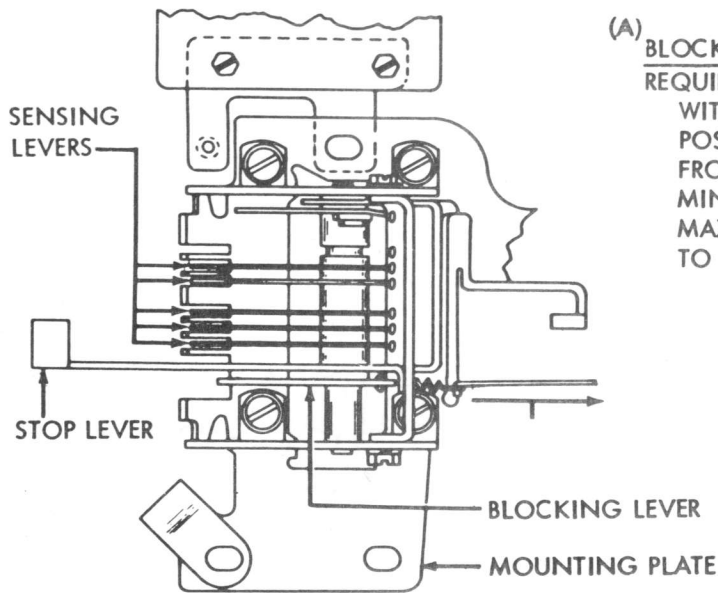

(A) BLOCKING LEVER SPRING  
 REQUIREMENT  
 WITH SIGNAL GENERATOR CLUTCH IN STOP POSITION, UNHOOK BLOCKING LEVER SPRING FROM STOP LEVER.  
 MIN. 1 OUNCE  
 MAX. 2 OUNCES  
 TO PULL SPRING TO INSTALLED LENGTH.

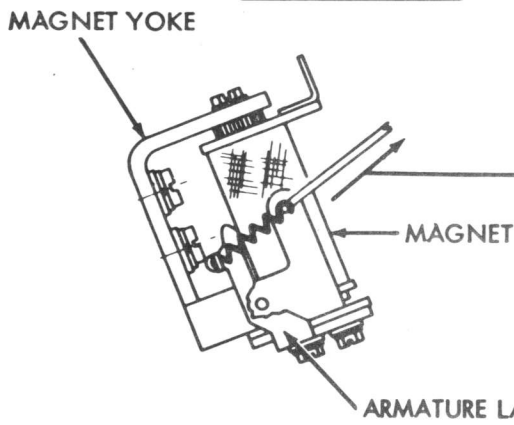

(B) ARMATURE LATCH SPRING  
 REQUIREMENT  
 WITH SIGNAL GENERATOR CLUTCH IN STOP POSITION, UNHOOK ARMATURE LATCH SPRING FROM SPRING POST ON MAGNET YOKE.  
 MIN. 2 OUNCES  
 MAX. 4 OUNCES  
 TO PULL SPRING TO INSTALLED LENGTH.

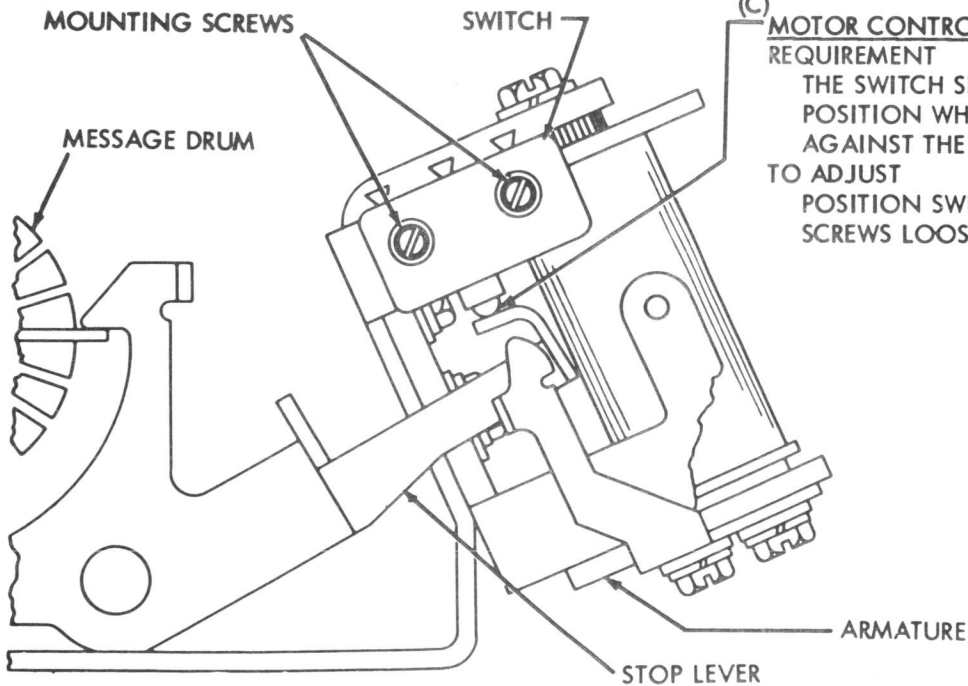

(C) MOTOR CONTROL RELAY SWITCH  
 REQUIREMENT  
 THE SWITCH SHOULD BE IN ITS OPERATED POSITION WHEN THE ARMATURE IS HELD AGAINST THE MAGNET CORE.  
 TO ADJUST POSITION SWITCH WITH ITS MOUNTING SCREWS LOOSENED.

3. 29 Answer-Back Mechanism continued  
CODING THE MESSAGE DRUM

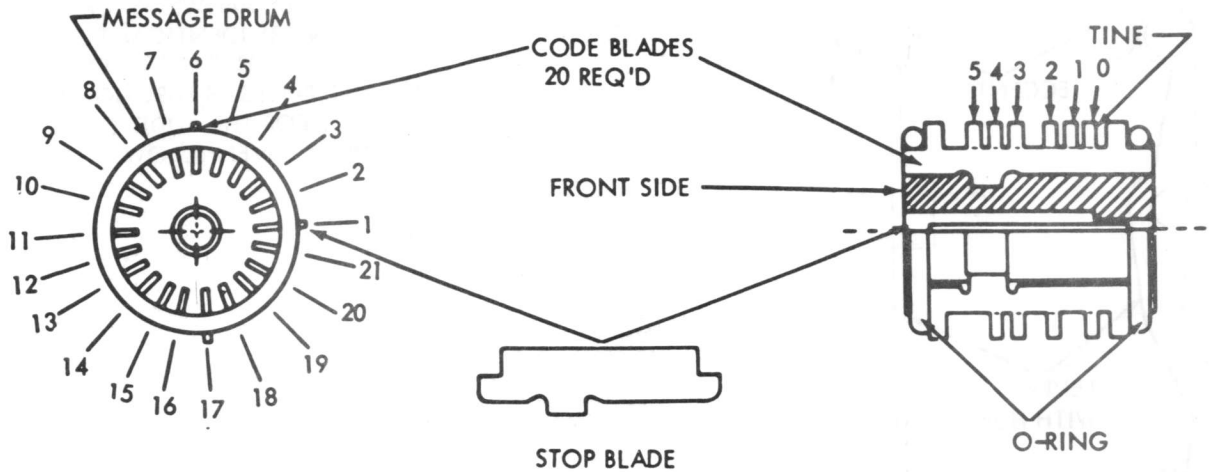

1. REMOVE MESSAGE DRUM FROM ANSWER BACK ASSEMBLY AND TAKE OUT CODE BLADES AS FOLLOWS: REMOVE DRIVE LINK SPRING ALLOWING DRIVE LINK TO DROP OUT OF ENGAGEMENT WITH STUD ON DRIVE PLATE. LIFT MESSAGE DRUM FROM NOTCHES. DEPRESS STEPPING PAWL EXTENSION AND PULL DRUM OFF SHAFT. REMOVE "O" RING FROM ONE END OF DRUM AND TAKE OUT TWENTY CODE BLADES. IT IS NOT NECESSARY TO TAKE OUT STOP BLADE.

LETTERS	TYPICAL FIG. ARRG'T	CODE				
		1	2	3	4	5
A	1	■	■	■	■	■
B	2	■	■	■	■	■
C	3	■	■	■	■	■
D	4	■	■	■	■	■
E	5	■	■	■	■	■
F	6	■	■	■	■	■
G	7	■	■	■	■	■
H	8	■	■	■	■	■
I	9	■	■	■	■	■
J	0	■	■	■	■	■
K	1	■	■	■	■	■
L	2	■	■	■	■	■
M	3	■	■	■	■	■
N	4	■	■	■	■	■
O	5	■	■	■	■	■
P	6	■	■	■	■	■
Q	7	■	■	■	■	■
R	8	■	■	■	■	■
S	BELL	■	■	■	■	■
T	9	■	■	■	■	■
U	0	■	■	■	■	■
V	1	■	■	■	■	■
W	2	■	■	■	■	■
X	3	■	■	■	■	■
Y	4	■	■	■	■	■
Z	5	■	■	■	■	■
CARRIAGE RETURN		■	■	■	■	■
LINE FEED		■	■	■	■	■
LETTERS SHIFT		■	■	■	■	■
FIGURES SHIFT		■	■	■	■	■
SPACE		■	■	■	■	■
BLANK		■	■	■	■	■

2. CODE A BLADE BY BREAKING OFF UNWANTED TINES AT SCORED LINE AT BASE OF EACH TINE. THE FIGURE BELOW INDICATES TINES TO BE REMOVED FOR A PARTICULAR CHARACTER. HOLD EACH BLADE SECURELY NEAR SCORE MARK OF TINE TO BE REMOVED. IN STANDARD 5 LEVEL OPERATION, THE 0 CODE LEVEL TINE IS DISREGARDED.
3. CODE THE DRUM IN A COUNTER-CLOCKWISE DIRECTION STARTING WITH NO. 2 CODE BLADE (ADJACENT TO STOP BLADE). BEGIN MESSAGE WITH "LETTERS" (STOP BLADE) FOLLOWED BY "CARRIAGE RETURN" AND "LINE FEED". END MESSAGE WITH "CARRIAGE RETURN" AND "LINE FEED". THIS LEAVES 16 CHARACTERS AVAILABLE FOR MESSAGE PROPER. CODE ANY UNUSED CHARACTERS WITH "LETTERS" OR "BLANKS", SINCE EACH SLOT POSITION IN DRUM MUST BE OCCUPIED BY A CODE BLADE.
4. INSTALL CODED BLADES IN PROPER SLOTS IN DRUM - INSERT END OF BLADE UNDER REMAINING "O" RING AND ROTATE THE BLADE TOWARD CENTER OF DRUM UNTIL IT IS FULLY SEATED. WHEN ALL THE SLOTS ARE FILLED REPLACE "O" RING REMOVED IN 1. ABOVE
5. APPLY GREASE TO SHAFT OF MESSAGE DRUM. REASSEMBLE MECHANISM REVERSING PROCEDURE OF STEP 1. BE SURE PARTS ARE PROPERLY SEATED. LUBRICATE PER INSTRUCTION IN SECTION 3.

■ — LEAVE TINE  
□ — REMOVE TINE



3.30 Answer-Back Mechanism ("Figs D")

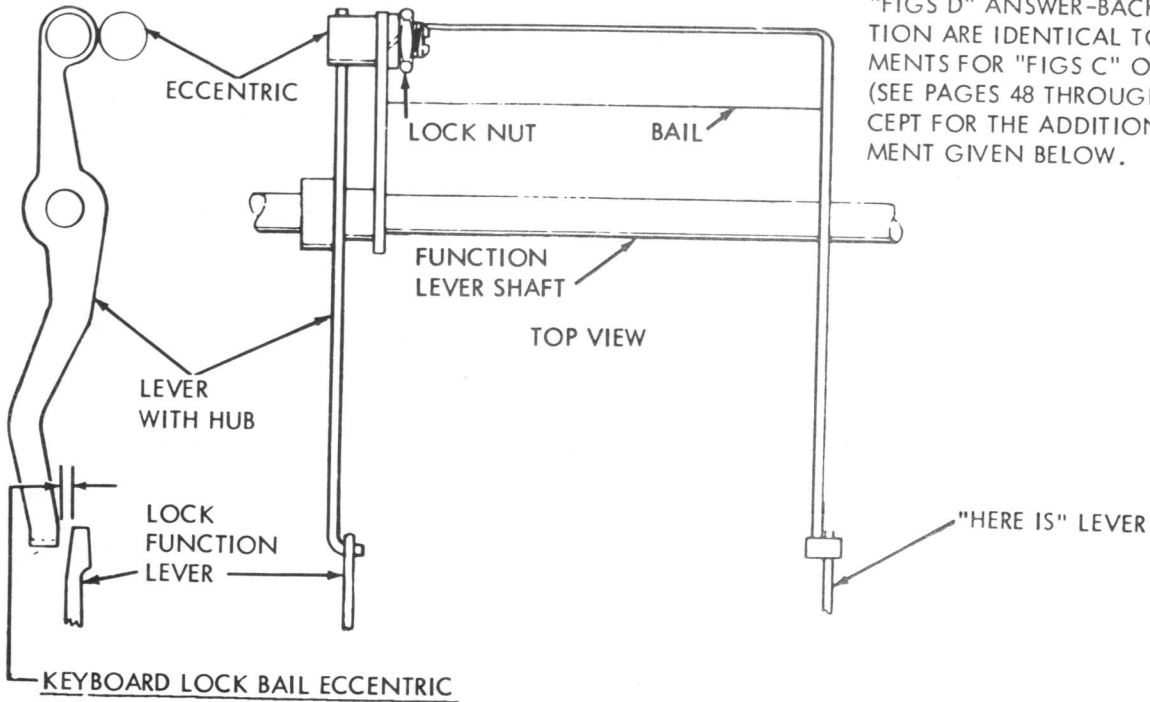

NOTE

ADJUSTMENT REQUIREMENTS FOR "FIGS D" ANSWER-BACK OPERATION ARE IDENTICAL TO REQUIREMENTS FOR "FIGS C" OPERATION (SEE PAGES 48 THROUGH 55) EXCEPT FOR THE ADDITIONAL REQUIREMENT GIVEN BELOW.

KEYBOARD LOCK BAIL ECCENTRIC REQUIREMENT

CLEARANCE BETWEEN KEYBOARD LOCK LEVER W/HUB AND KEYBOARD LOCK FUNCTION LEVER SHOULD BE  
MIN. SOME --- MAX. 0.006 INCH

TO CHECK

FULLY DEPRESS BOTH "KYBD LOCK" AND "HERE IS" KEYS (HOLD LIGHTLY).

TO ADJUST

LOOSEN LOCK NUT AND POSITION ECCENTRIC WITH ITS HIGH POINT TOWARD FRONT OF KEYBOARD.

## 3.31 Clutch Trip Delay Mechanism

CLUTCH TRIP DELAY  
REQUIREMENT

PLACE KEYBOARD IN K-T POSITION. WITH KEYBOARD IN ITS TRIPPED POSITION AND SIGNAL GENERATOR SHAFT ROTATED SO THAT CLUTCH IS APPROXIMATELY 180 DEGREES FROM ITS LATCHED POSITION, DEPRESS LTRS KEYLEVER. SLOWLY CONTINUE ROTATION OF SIGNAL GENERATOR SHAFT IN CLOCKWISE DIRECTION NOTING GAP BETWEEN NEAREST EDGE OF CLUTCH SHOE LEVER AND CLUTCH STOP LEVER. CODEBAR BAIL SHALL NOT TRIP UNTIL GAP MEASURES

MIN. 3/8 INCH

MAX. 1/2 INCH

TO ADJUST

POSITION BLOCKING LEVER WITH CLAMPING SCREW FRICTION TIGHT, UTILIZING PRY POINTS PROVIDED.

NOTE: IF SIGNAL DISTORTION TEST SET IS AVAILABLE, MINIMUM GAP REQUIREMENT SHALL BE CONSIDERED MET IF 100 WPM SIGNAL GENERATOR STROBE REQUIREMENTS CAN BE MET.

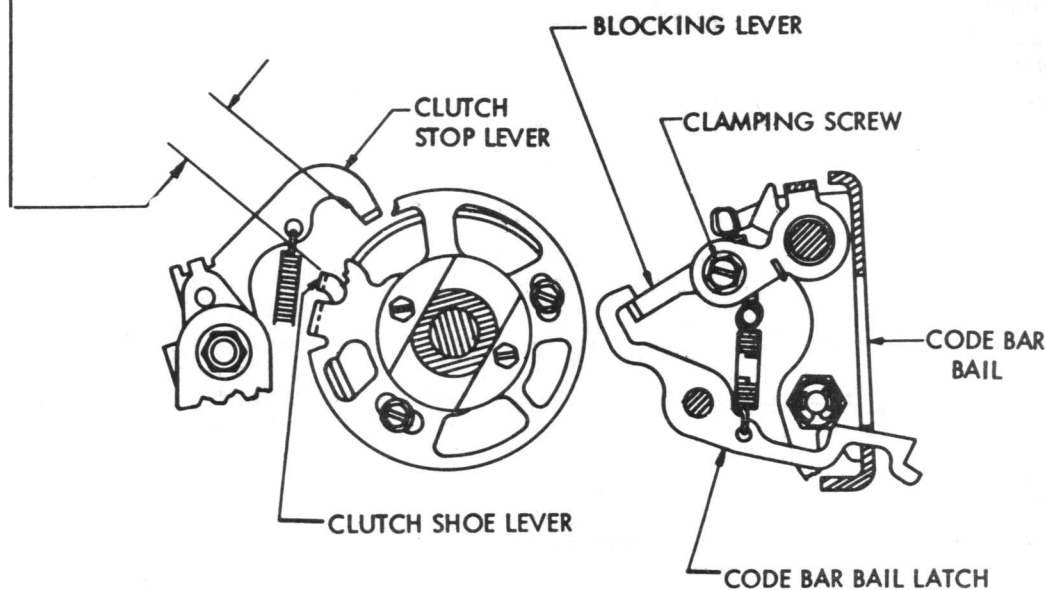
TRIP DELAY TORSION SPRING  
REQUIREMENT

WITH KEYBOARD CLUTCH DISENGAGED, APPLY PUSH END OF 8 OZ. SCALE VERTICALLY TO EDGE OF FORMED END OF BLOCKING LEVER.

MIN. 4-1/2 OZS.

MAX. 8 OZS.

TO START BLOCKING LEVER MOVING.

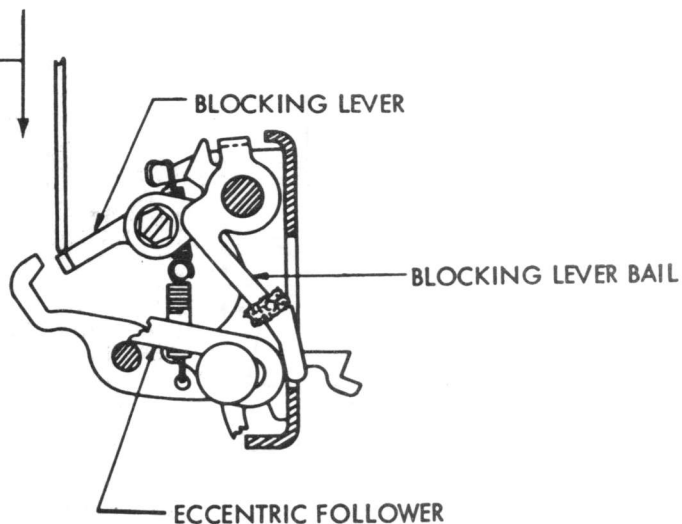

3.32 Auxiliary Contacts

AUXILIARY CONTACTS

(1) REQUIREMENT  
 CLUTCH DISENGAGED AND LATCHED, CAM FOLLOWER OFF ITS CAM. CLEARANCE BETWEEN CONTACT POINTS  
 MIN. 0.015 INCH  
 MAX. 0.025 INCH  
 TO ADJUST POSITION SET SCREW WITH LOCK NUT LOOSENED.

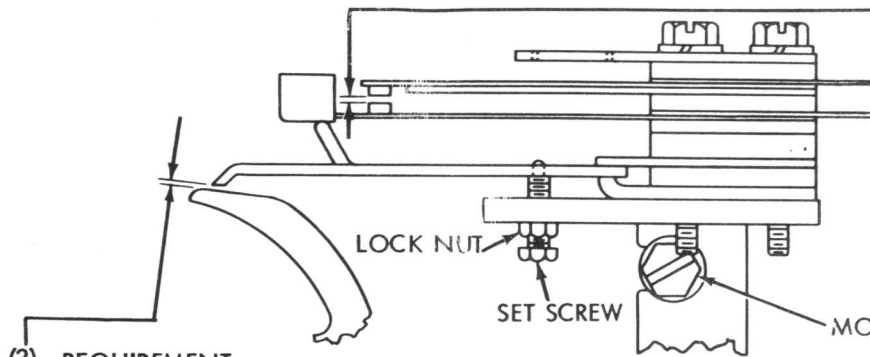

(2) REQUIREMENT  
 CLUTCH DISENGAGED. CLEARANCE BETWEEN CAM FOLLOWER AND CAM  
 MIN. SOME  
 MAX. 0.005  
 TO ADJUST POSITION MOUNTING BRACKET WITH ITS MOUNTING SCREWS LOOSENED. THIS ADJUSTMENT IS TO BE REFINED WHEN STROBING IS DONE.

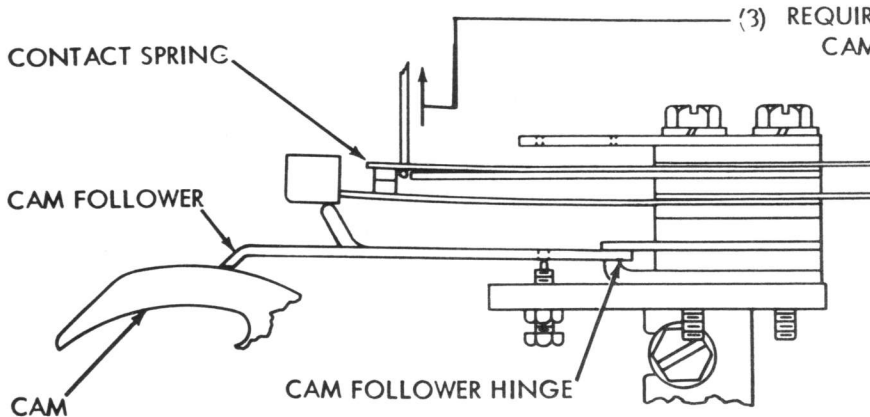

(3) REQUIREMENT  
 CAM FOLLOWER ON HIGH PART OF CAM  
 MIN. 3-1/2 OZS.  
 MAX. 4-1/2 OZS.  
 TO SEPARATE THE CONTACTS  
 TO ADJUST BEND UPPER CONTACT SPRING

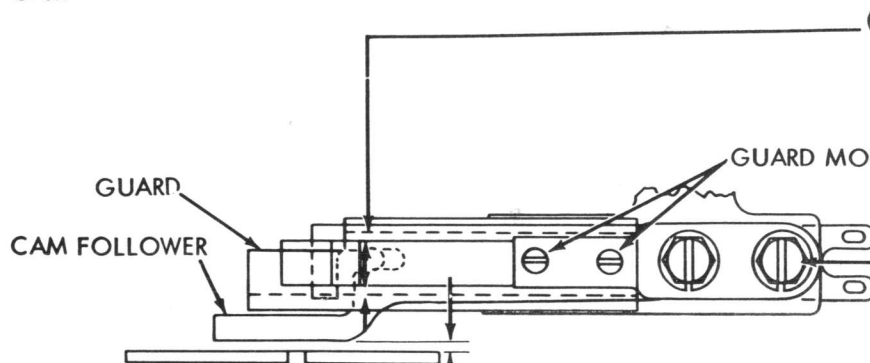

(4) REQUIREMENT  
 MIN. 0.010 INCH  
 BETWEEN THE CONTACT GUARD AND THE CONTACT SPRINGS.

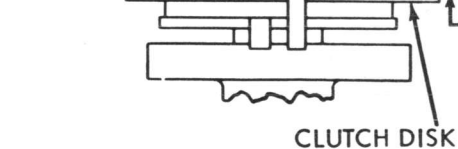

(5) REQUIREMENT  
 WITH THE CLUTCH DISENGAGED AND LATCHED CLEARANCE BETWEEN THE LOWER EXTENSION OF THE CAM FOLLOWER AND THE INSIDE SURFACE OF THE CLUTCH DISK  
 MIN. SOME  
 TO ADJUST POSITION THE CONTACT SPRINGS CONTACT GUARD AND CAM FOLLOWER HINGE WITH THEIR MOUNTING SCREWS LOOSENED.

3.33 Letters and Figures Contacts

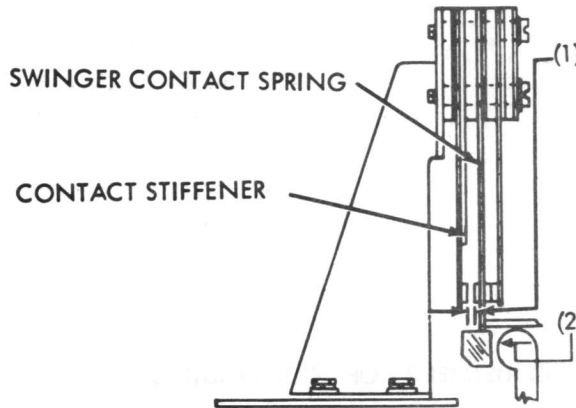

LETTERS-FIGURES CONTACT

REQUIREMENT

CLUTCH DISENGAGED AND LATCHED THEN LETTERS OR FIGURES KEYLEVER DEPRESSED. LEFT HAND CONTACT GAP

MIN. 0.012 INCH  
MAX. 0.018 INCH

TO ADJUST

BEND CONTACT STIFFENER. CHECK BOTH CONTACT ASSEMBLIES.

REQUIREMENT

CLUTCH DISENGAGED AND LATCHED, THEN LETTERS OR FIGURES KEYLEVER DEPRESSED

MIN. 4-1/2 OZS.  
MAX. 5-1/2 OZS.

TO SEPARATE CONTACTS

TO ADJUST

BEND SWINGER. RECHECK CONTACT GAPS.

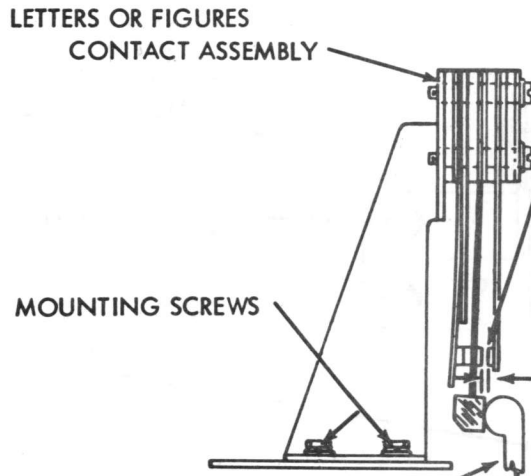

RIGHT HAND CONTACT POINTS

(3) REQUIREMENT

CLUTCH DISENGAGED AND LATCHED, THEN ANY KEYLEVER OTHER THAN LETTERS OR FIGURES DEPRESSED. RIGHT CONTACT GAP

MIN. 0.012 INCH  
MAX. 0.018 INCH

CHECK BOTH LETTERS OR FIGURES CONTACTS

TO ADJUST

POSITION CONTACT ASSEMBLY WITH ITS BRACKET MOUNTING SCREWS LOOSENED.

CODE BAR EXTENSIONS

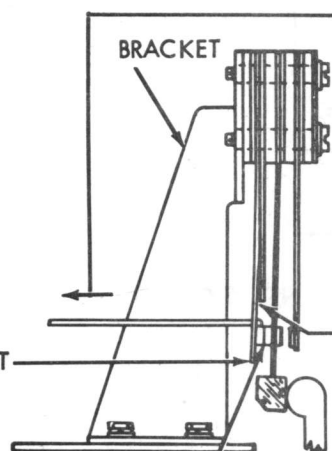

(5) REQUIREMENT

CLUTCH DISENGAGED AND LATCHED, THEN ANY KEYLEVER OTHER THAN LETTERS OR FIGURES DEPRESSED.

MIN. 4-1/2 OZS.  
MAX. 5-1/2 OZS.

TO SEPARATE LEFT HAND CONTACT POINTS

TO ADJUST

BEND LEFT CONTACT SPRING. CHECK BOTH CONTACT ASSEMBLIES. RECHECK CONTACT GAP.

(4) REQUIREMENT

CLUTCH DISENGAGED AND LATCHED, THEN WITH ANY KEYLEVER OTHER THAN LETTERS OR FIGURES DEPRESSED CLEARANCE BETWEEN LEFT CONTACT SPRING AND ITS STIFFENER

MIN. 0.003 INCH

TO ADJUST

REFINE POSITION OF CONTACT ASSEMBLY BRACKET

SECTION 573-117-700

3.34 Code Reading Contacts (Transmitting)

NOTE: REFER TO SECTION 573-139-700 FOR OTHER ADJUSTMENTS OF CODE READING CONTACTS.

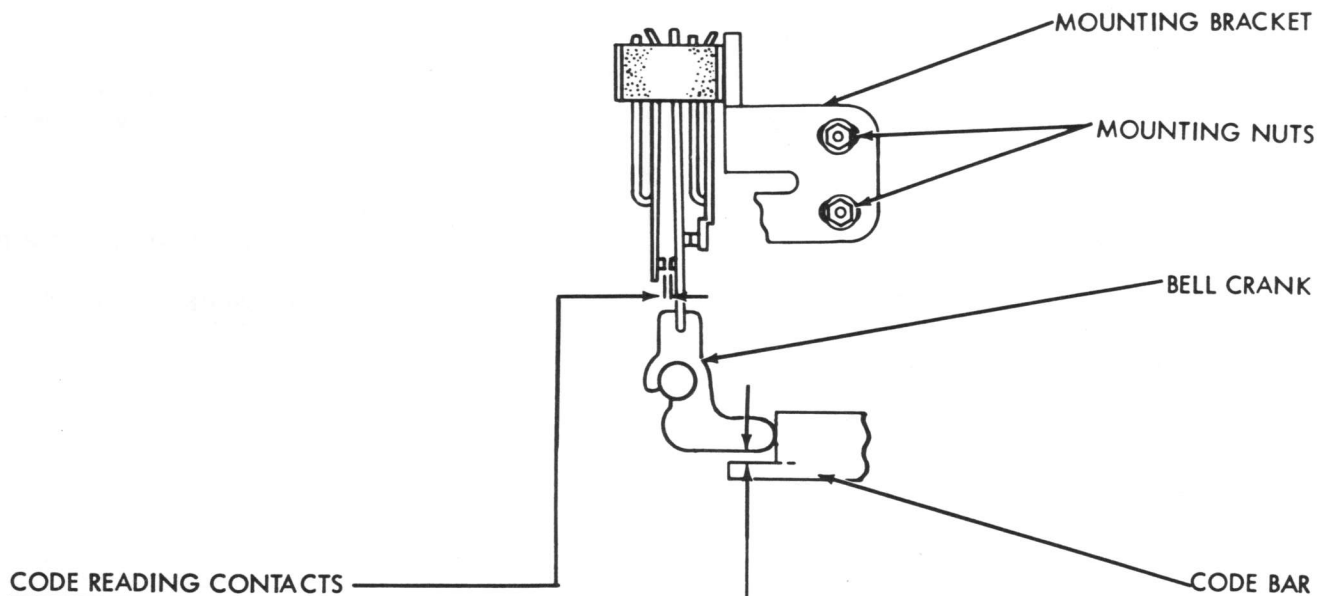

CODE READING CONTACTS

- (1) REQUIREMENT  
CLUTCH DISENGAGED AND LATCHED. CLEARANCE  
BEWTEEN LEFT SIDE CONTACT POINTS  
MIN. 0.030 INCH  
MAX. 0.035 INCH
- (2) REQUIREMENT  
CLEARANCE BETWEEN THE LOWER SURFACE OF  
BELLCRANK AND THE CODE BAR (CHECK NO. 1 AND NO. 5 ONLY)  
MIN. 0.050 INCH  
MAX. 0.065 INCH
- (3) REQUIREMENT  
LOWER SURFACE OF BELLCRANK SHOULD BE  
PARALLEL TO THE CODE BAR  
TO ADJUST  
POSITION THE MOUNTING BRACKET WITH ITS  
MOUNTING NUTS LOOSENED.