

28 PERFORATOR-TRANSMITTER BASE

LUBRICATION

CONTENTS	PAGE	CONTENTS	PAGE
1. GENERAL . . . . .	1-2	Lockbar latch mechanism . . . . .	10
2. LUBRICATION . . . . .	3	Locking bail mechanism . . . . .	12
Answer-Back Mechanism		Margin indicating mechanism . . . . .	10
Answer-back armature mechanism . .	20	Nonrepeat lever mechanism . . . . .	8
Answer-back codebars and sensing levers . . . . .	22	Remote control gear shift . . . . .	18
Answer-back driving mechanism . . .	22	Repeat on space mechanism . . . . .	16
Answer-back keyboard lock bail mechanism . . . . .	23	Reset cam follower mechanism . . . . .	13
Answer-back mechanism . . . . .	20	Selector lever mechanism . . . . .	5
Answer-back sensing lever mechanism . . . . .	20	Signal generator mechanism . . . . .	8-12
Answer-back stepping pawl . . . . .	23	Space bar mechanism . . . . .	3
Answer-back stop lever . . . . .	21	Synchronous pulse . . . . .	17
Keyboard Mechanism		Synchronous pulsed magnet . . . . .	17
Break lever mechanism . . . . .	4	mechanism . . . . .	19
Character counter and electrical break mechanism . . . . .	14	Time delay mechanism . . . . .	10
Character counter . . . . .	14-15	Transfer bail mechanism . . . . .	9
Clutch tripbar link mechanism . . . . .	6	Transfer lever mechanism . . . . .	13
Clutch tripbar mechanism . . . . .	9	Universal bail latchlever mechanism .	13
Codebar and local line feed mechanism . . . . .	7		
Codebar bail mechanism . . . . .	13	1. GENERAL	
Codebar extension bail mechanism . .	6	1.01 This section has been revised to include recent engineering changes and additions, and to rearrange the text so as to bring the section generally up-to-date. Since this is an extensive revision, marginal arrows ordinarily used to indicate changes have been omitted.	
Codebar extension mechanism . . . . .	6	1.02 The 28 Perforator-Transmitter Base should be lubricated as directed in this section. The figures indicate points to be lubricated and the kind and quantity of lubricant to be used. Lubricate the keyboard just prior to placing it in service. After a few weeks in service, relubricate to make certain that all points receive lubrication. The following lubrication schedule should be followed thereafter:	
Codebar guide . . . . .	17		
Codebar mechanism . . . . .	7	<u>OPERATING SPEEDS</u>	<u>LUBRICATION</u>
Codelever mechanism . . . . .	4	<u>IN WORDS PER MINUTE</u>	<u>INTERVAL</u>
Codelever universal bail mechanism .	7	60	3000 hr or 1 yr*
Contact box . . . . .	9	75	2400 hr or 9 mo*
Contact swinger . . . . .	17	100	1500 hr or 6 mo*
Detent lever mechanism . . . . .	5	150	1000 hr or 6 mo*
Electrical line break mechanism . . .	15		
Extension basket mechanism . . . . .	5		
Intermediate gear mechanism . . . . .	11		
Keyboard . . . . .	3		
Keyboard clutch mechanism . . . . .	10		
Keyboard lock mechanism . . . . .	4		
Keyboard mechanism . . . . .	11		
Keyboard shaft mechanism . . . . .	3		
Local carriage return mechanism . . .	8		
Local line feed mechanism . . . . .	11		
Local paper feed-out mechanism . . .	15		

\*Whichever occurs first.

SECTION 573-117-701

1.03 Use TP88970 oil at all locations where the use of oil is indicated. Use TP88973 grease on all surfaces where grease is indicated.

1.04 All spring wicks and felt oilers should be saturated. The friction surfaces of all moving parts should be thoroughly lubricated. Over-lubrication, however, which will permit oil or grease to drip or be thrown on other parts, should be avoided. Special care must be taken to prevent any oil or grease from getting between electrical contacts.

1.05 Apply a thick film of grease to all gears.

1.06 Apply oil to all cams, including the camming surfaces of each clutch disc.

1.07 The photographs show the paragraph numbers referring to particular line drawings of mechanisms and where these mechanisms are located on the unit. Parts in the line drawings are shown in an upright position unless otherwise specified.

1.08 The illustration symbols indicate the following lubrication directions:

- O Apply 1 drop of oil.
- O2 Apply 2 drops of oil.
- O3 Apply 3 drops of oil.
- O20 Apply 20 drops of oil, etc.
- G Apply thin film of grease.
- SAT Saturate (felt oilers, washers, wicks) with oil.

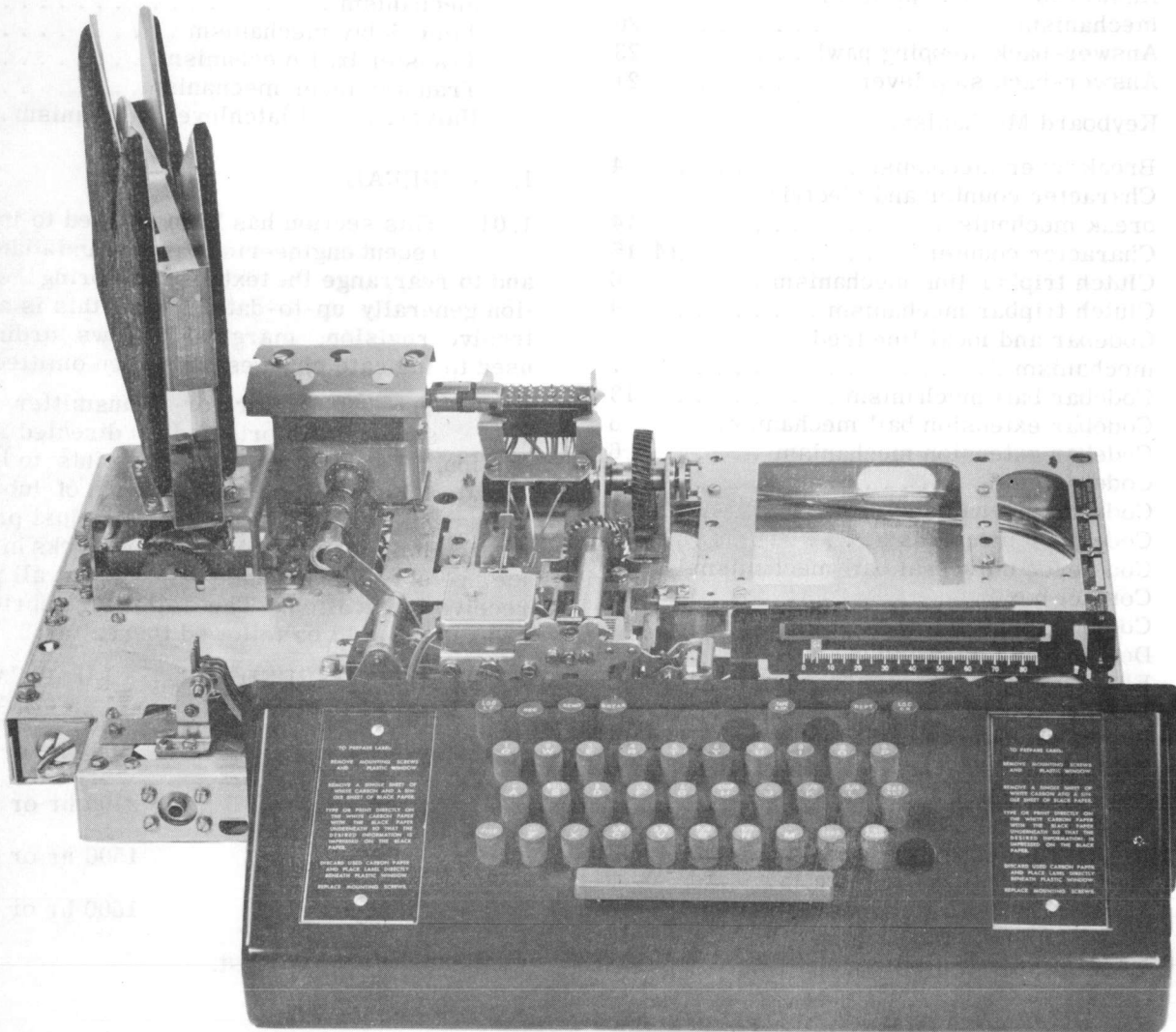
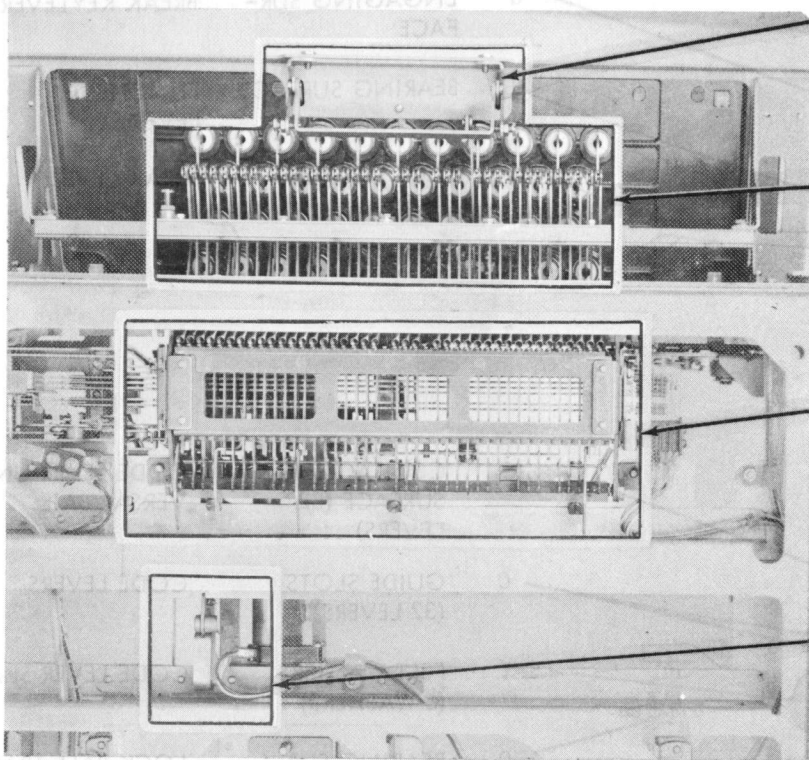

Figure 1 - 28 Perforator-Transmitter Base

2. LUBRICATION

2.01 KEYBOARD

NOTE: REST PERFORATOR TRANSMITTER BOTTOM SIDE UP.



(BOTTOM VIEW)

2.02 SPACE BAR MECHANISM

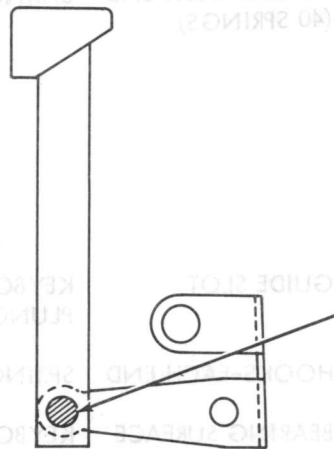

0 BEARING SURFACE SPACE BAR (LEFT & RIGHT)

2.03 KEYLEVER MECHANISM

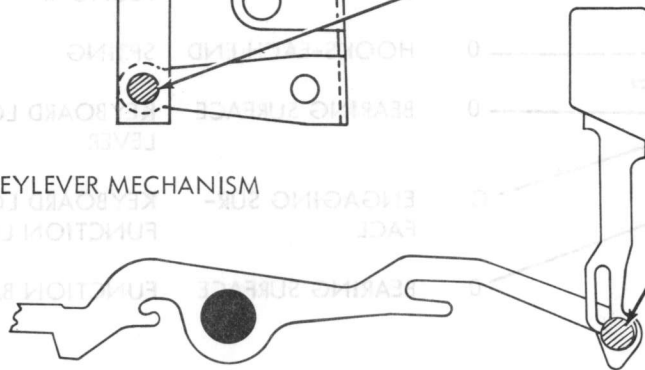

0 ENGAGING SURFACE (36 LEVERS) KEYPAD LEVERS

2.04 BREAK LEVER MECHANISM

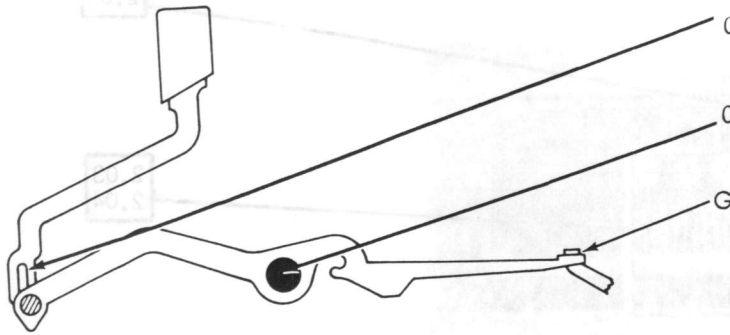

- 0 ENGAGING SURFACE BREAK KEYLEVER FACE
- 0 BEARING SURFACE FUNCTION LEVER
- G CONTACT SURFACE BREAK LEVER FACE

2.05 CODE LEVER MECHANISM

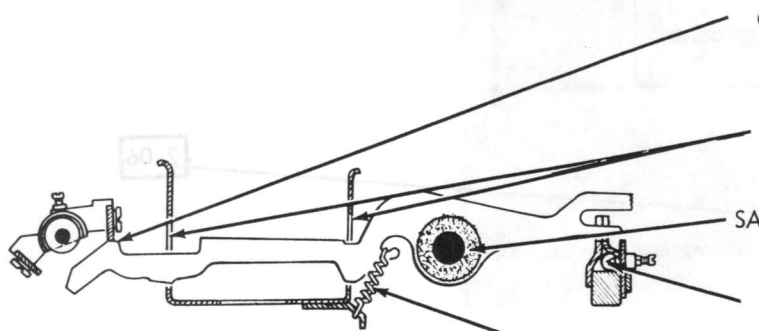

- G CONTACTING SURFACE (32 LEVERS) CODE LEVER UNIVERSAL BAIL
- 0 GUIDE SLOTS (32 LEVERS) CODE LEVERS
- SAT FELT WASHERS (6 WASHERS) CODE LEVER SHAFT
- 0 BEARING SURFACES (32 WEDGES) LOCK BALL TRACK
- 0 HOOKS-EACH END (40 SPRINGS) SPRING

2.06 KEYBOARD LOCK MECHANISM

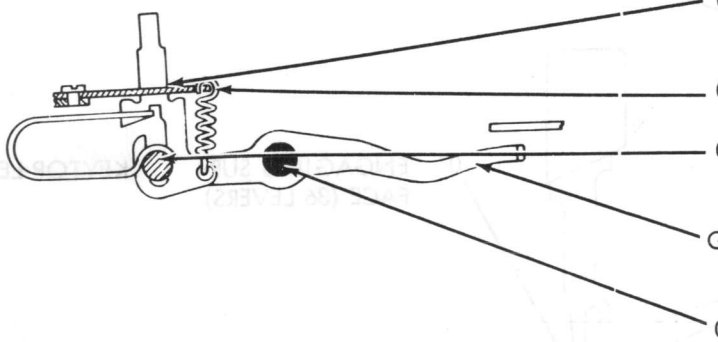

- 0 GUIDE SLOT KEYBOARD LOCK PLUNGER
- 0 HOOKS-EACH END SPRING
- 0 BEARING SURFACE KEYBOARD LOCK LEVER
- G ENGAGING SURFACE KEYBOARD LOCK FUNCTION LEVER
- 0 BEARING SURFACE FUNCTION BAIL

2.07 EXTENSION BASKET MECHANISM

NOTE: REST PERFORATOR TRANSMITTER BOTTOM SIDE UP.

SECTION 573-117-701

- 2.08
- 2.09
- 2.10
- 2.11
- 2.12

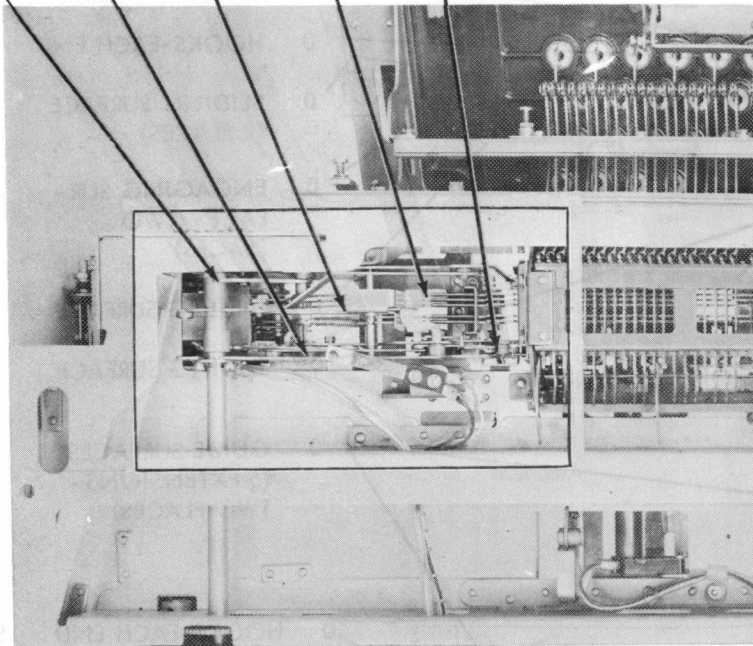

(BOTTOM VIEW)

2.08 DETENT LEVER MECHANISM

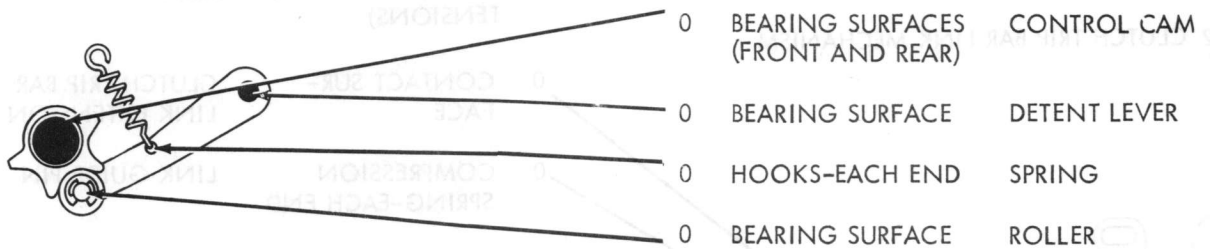

2.09 SELECTOR LEVER MECHANISM

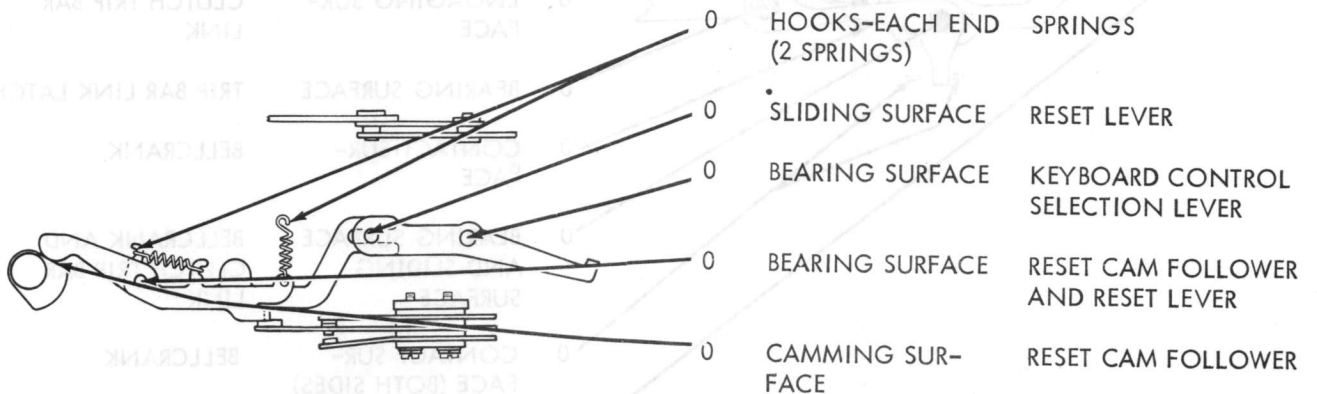

SECTION 573-117-701

2.10 CODE BAR EXTENSION BAIL MECHANISM

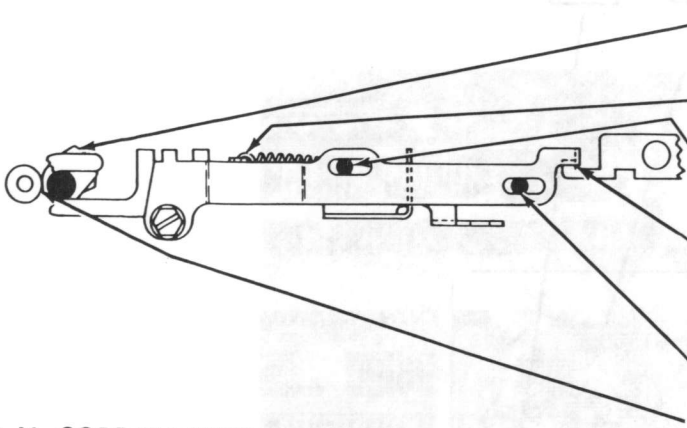

- 0 CAMMING SURFACE SLIDE ROLLER
- 0 HOOKS-EACH END SPRING
- 0 SLIDING SURFACE (2 PLACES) LEVER AND EXTENSION
- 0 ENGAGING SURFACES (TWO PLACES) LEVER
- 0 SLIDING SURFACE LEVER
- 0 SLIDING SURFACE CONTROL CAM

2.11 CODE BAR EXTENSION MECHANISM

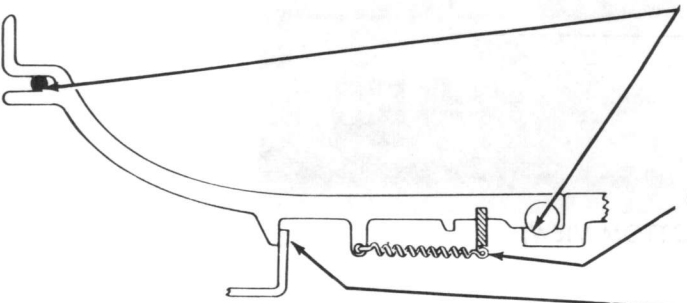

- 0 GUIDE SURFACES (5 EXTENSIONS-TWO PLACES) CODE BAR EXTENSIONS
- 0 HOOKS-EACH END (5 SPRINGS) SPRINGS
- 0 CONTACT SURFACE (5 EXTENSIONS) CODE BAR EXTENSION

2.12 CLUTCH TRIP BAR LINK MECHANISM

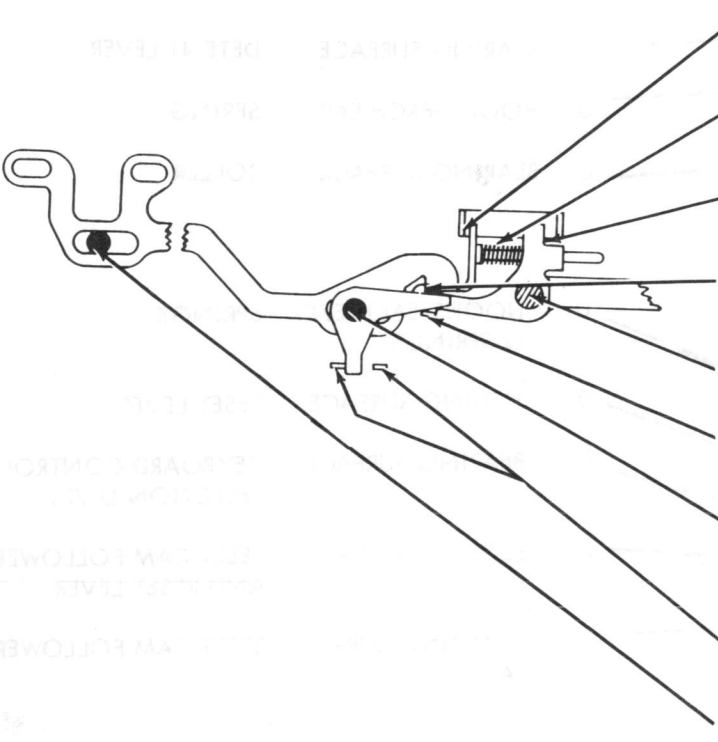

- 0 CONTACT SURFACE CLUTCH TRIP BAR LINK EXTENSION
- 0 COMPRESSION SPRING-EACH END LINK GUIDE PIN
- 0 CONTACT SURFACE TRIP BAR LINK LATCH
- 0 ENGAGING SURFACE CLUTCH TRIP BAR LINK
- 0 BEARING SURFACE TRIP BAR LINK LATCH
- 0 CONTACT SURFACE BELLCRANK
- 0 BEARING SURFACE AND SLIDING SURFACE BELLCRANK AND CLUTCH TRIP BAR LINK
- 0 CONTACT SURFACE (BOTH SIDES) BELLCRANK
- 0 SLIDING SURFACE CLUTCH TRIP BAR LINK

2.13 CODE BAR AND LOCAL LINE FEED MECHANISM  
 NOTE: REST PERFORATOR IN UPRIGHT POSITION.

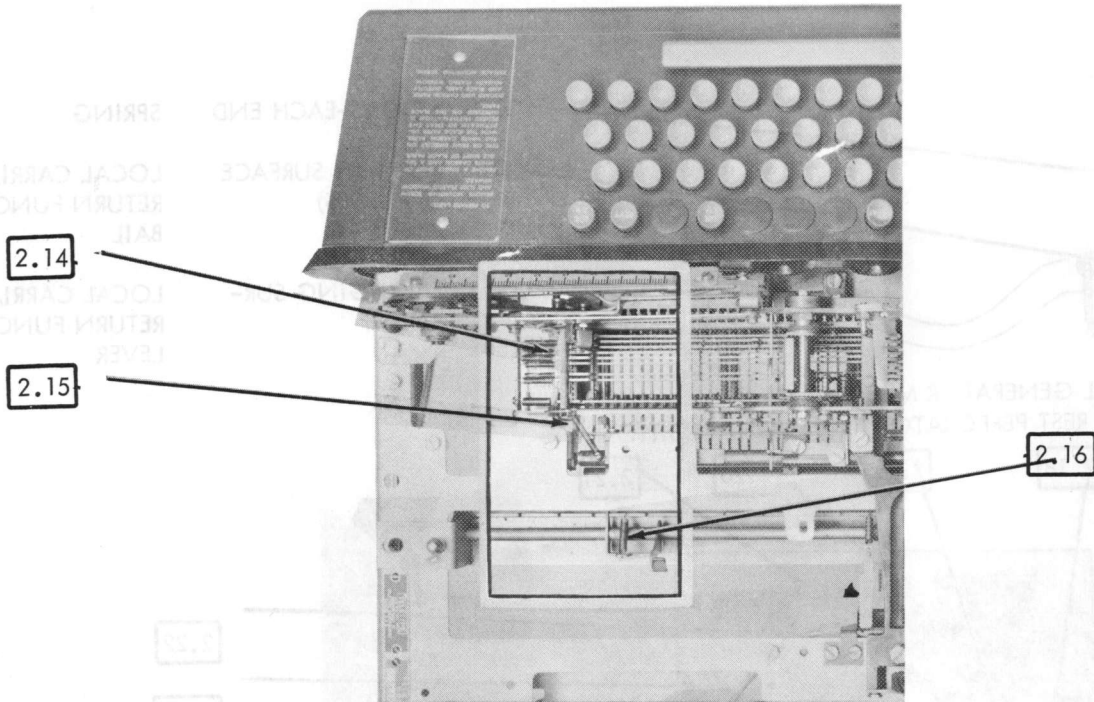

(TOP VIEW)

2.14 CODE BAR MECHANISM

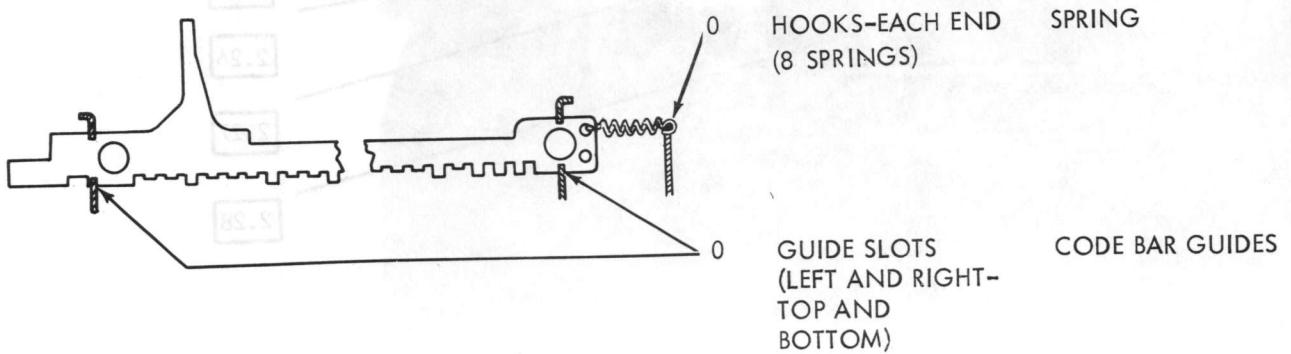

2.15 CODE LEVER UNIVERSAL BAIL MECHANISM



SECTION 573-117-701

2.16 LOCAL CARRIAGE RETURN MECHANISM

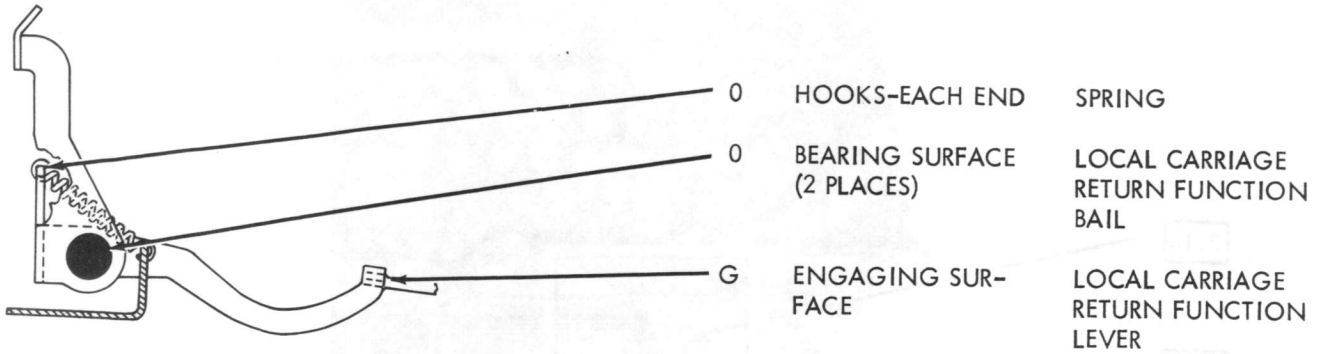

2.17 SIGNAL GENERATOR MECHANISM  
NOTE: REST PERFORATOR IN UPRIGHT POSITION.

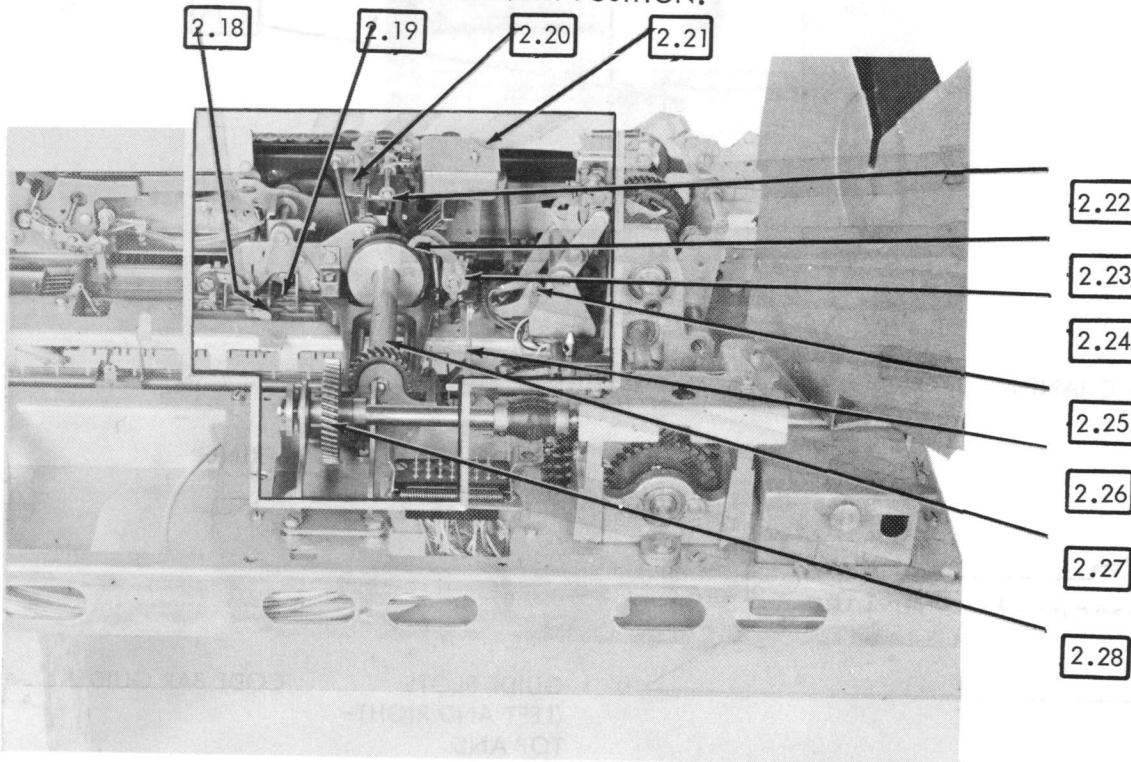

(REAR VIEW)

2.18 NON-REPEAT LEVER MECHANISM

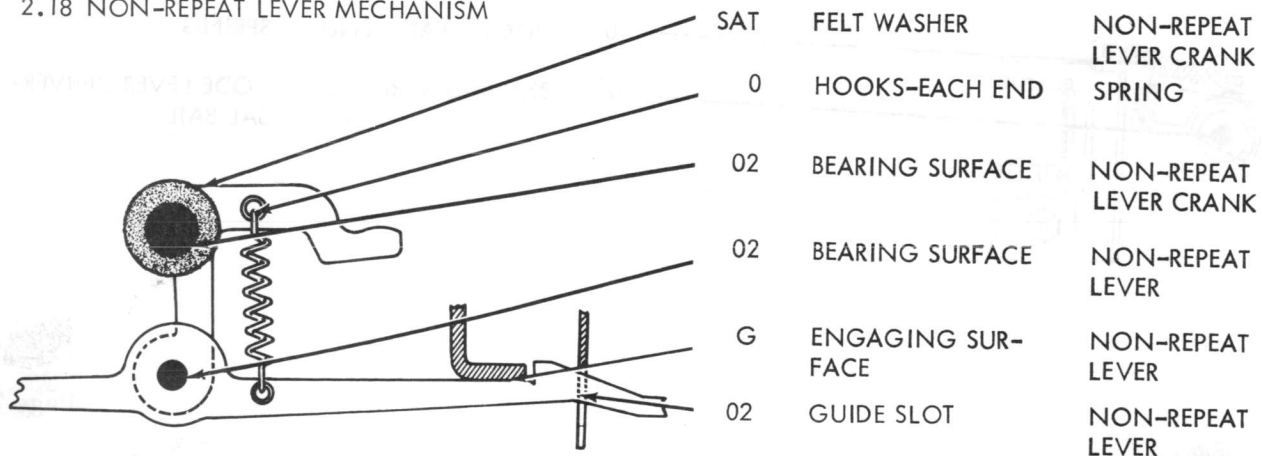



2.19 CLUTCH TRIP BAR MECHANISM

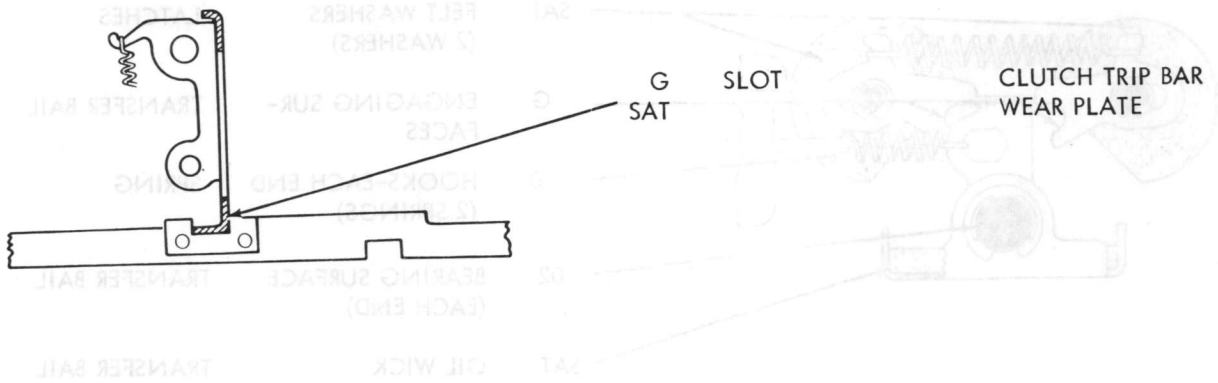

2.20 TRANSFER LEVER MECHANISM

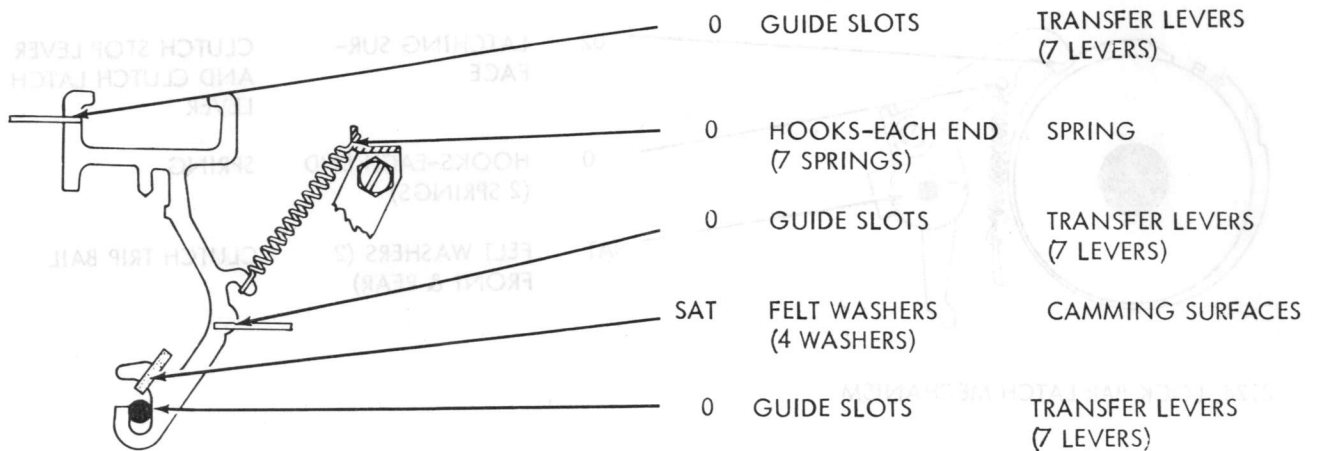

2.21 CONTACT BOX

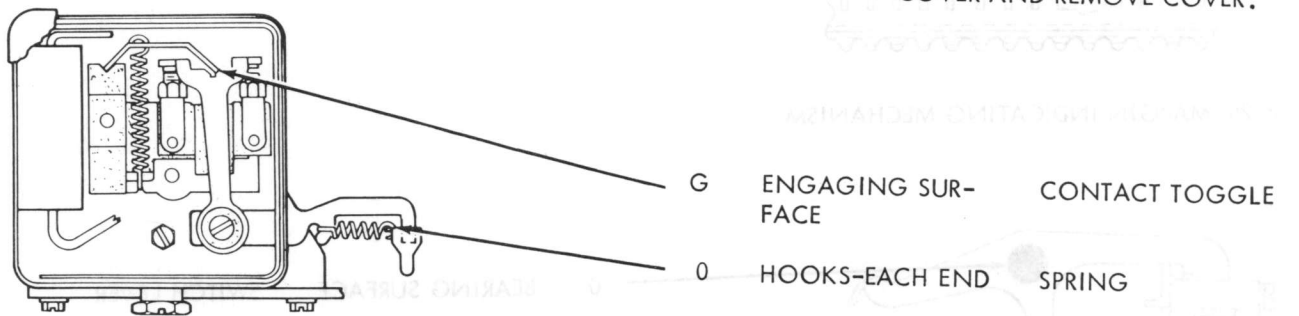

SECTION 573-117-701

2.22 TRANSFER BAIL MECHANISM

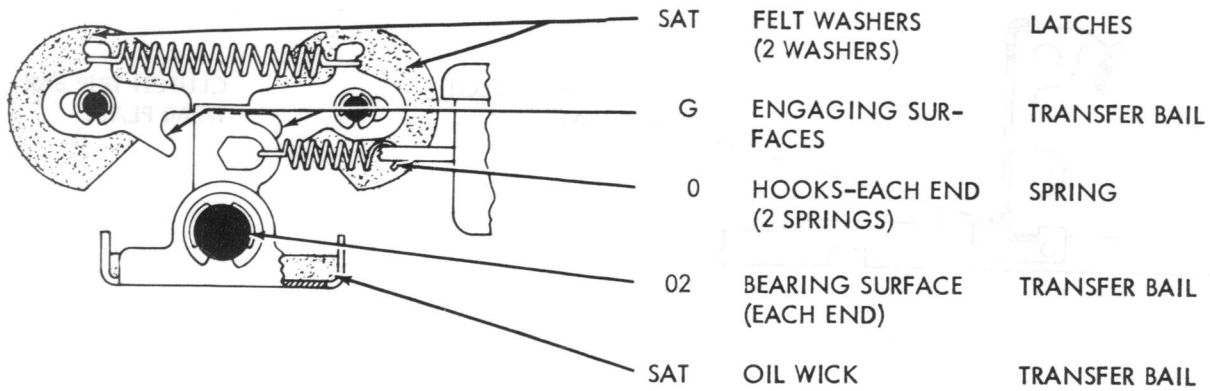

2.23 KEYBOARD CLUTCH MECHANISM

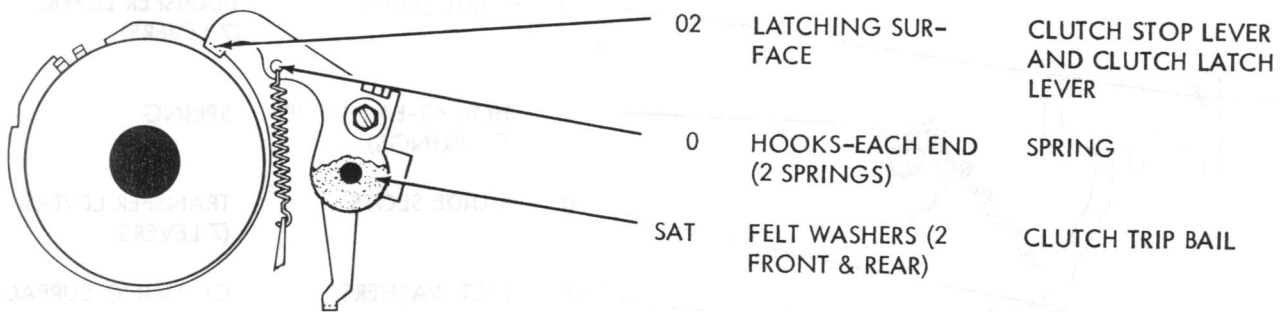

2.24 LOCK BAR LATCH MECHANISM

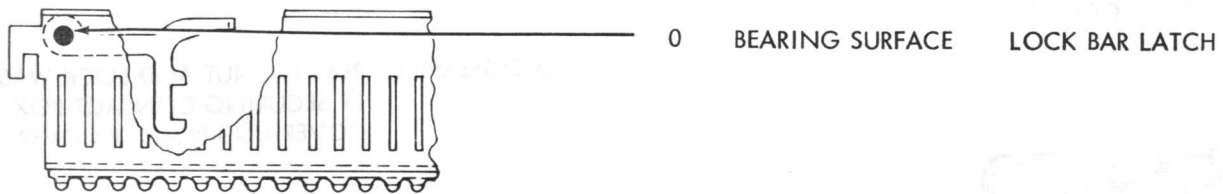

2.25 MARGIN INDICATING MECHANISM



2.26 LOCAL LINE FEED MECHANISM

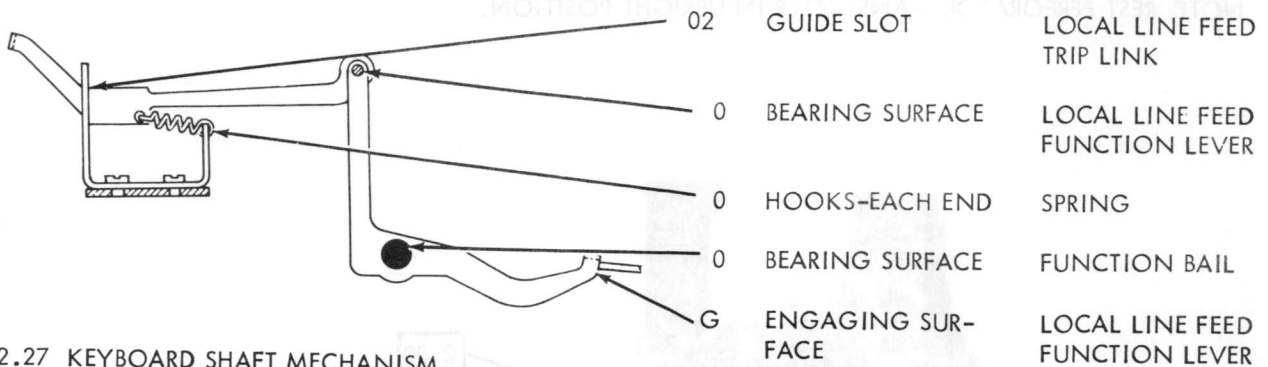

2.27 KEYBOARD SHAFT MECHANISM

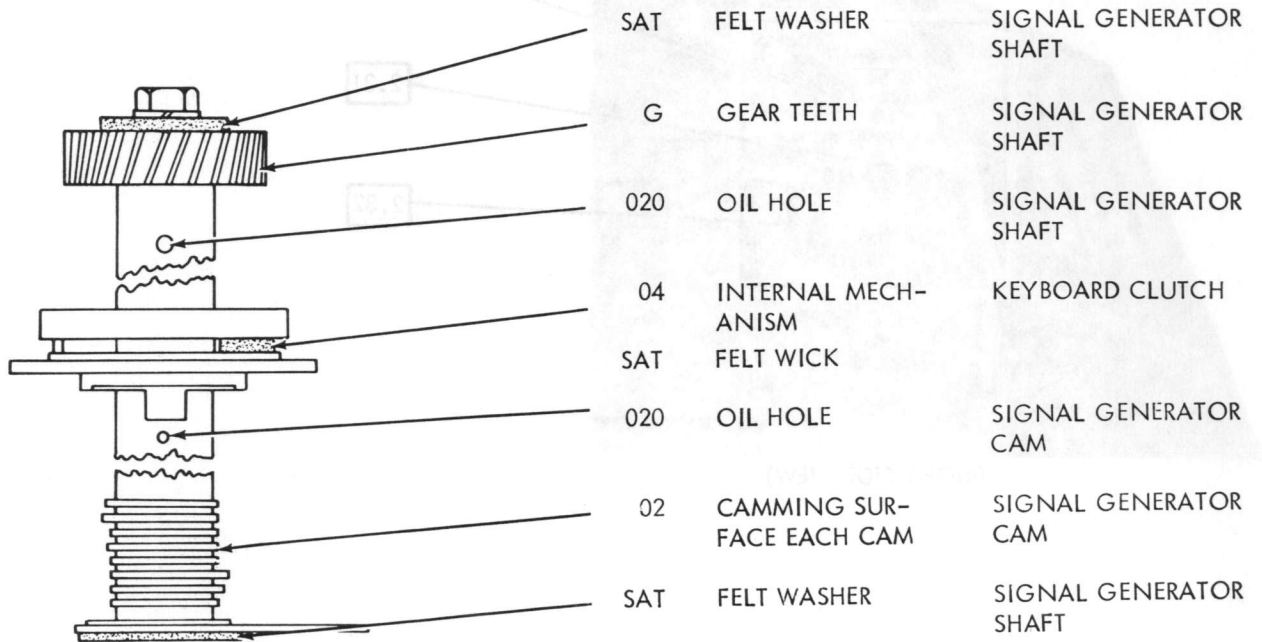

2.28 INTERMEDIATE GEAR MECHANISM

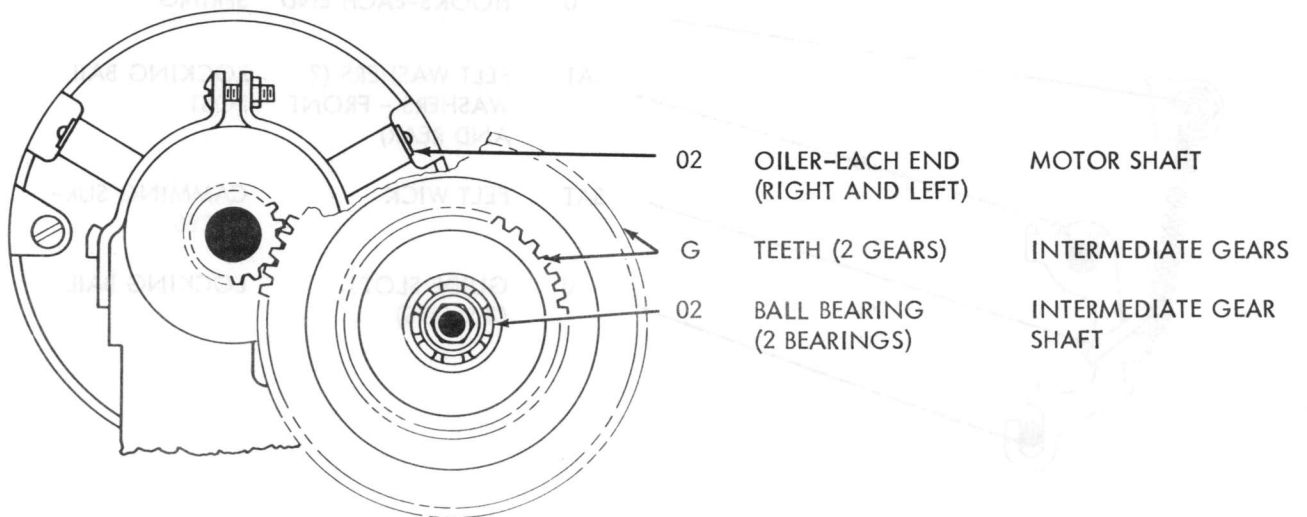

2.29 SIGNAL GENERATOR MECHANISM continued

NOTE: REST PERFORATOR TRANSMITTER IN UPRIGHT POSITION.

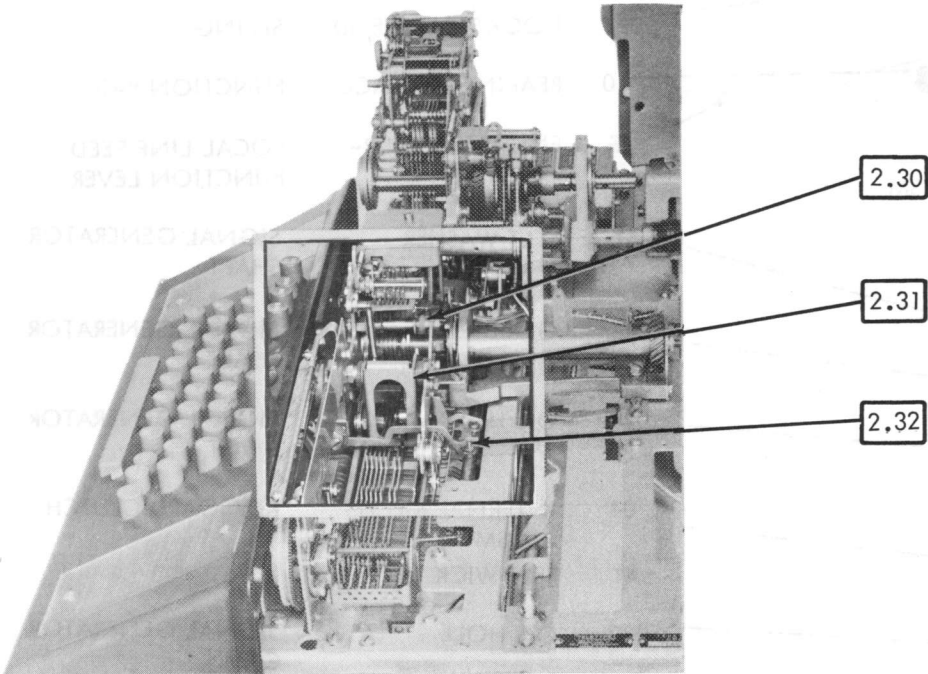

(RIGHT SIDE VIEW)

2.30 LOCKING BAIL MECHANISM

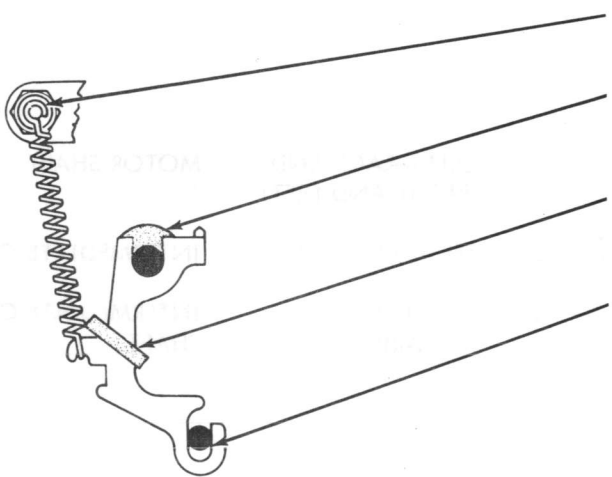

- |     |   |                       |
|-----|---|-----------------------|
| 0   | HOOKS-EACH END                                  | SPRING                |
| SAT | FELT WASHERS (2<br>WASHERS - FRONT<br>AND REAR) | LOCKING BAIL<br>POST  |
| SAT | FELT WICK                                       | CAMMING SUR-<br>FACES |
| 0   | GUIDE SLOTS<br>(3 SLOTS)                        | LOCKING BAIL          |

2.31 CODE BAR BAIL MECHANISM

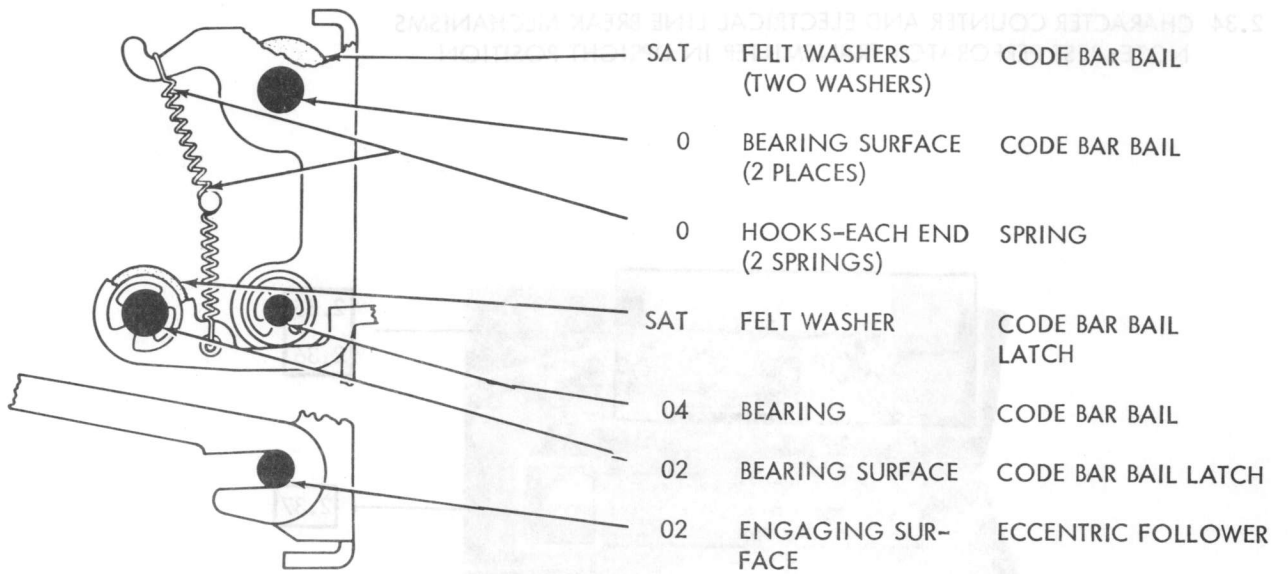

2.32 UNIVERSAL BAIL LATCH LEVER MECHANISM

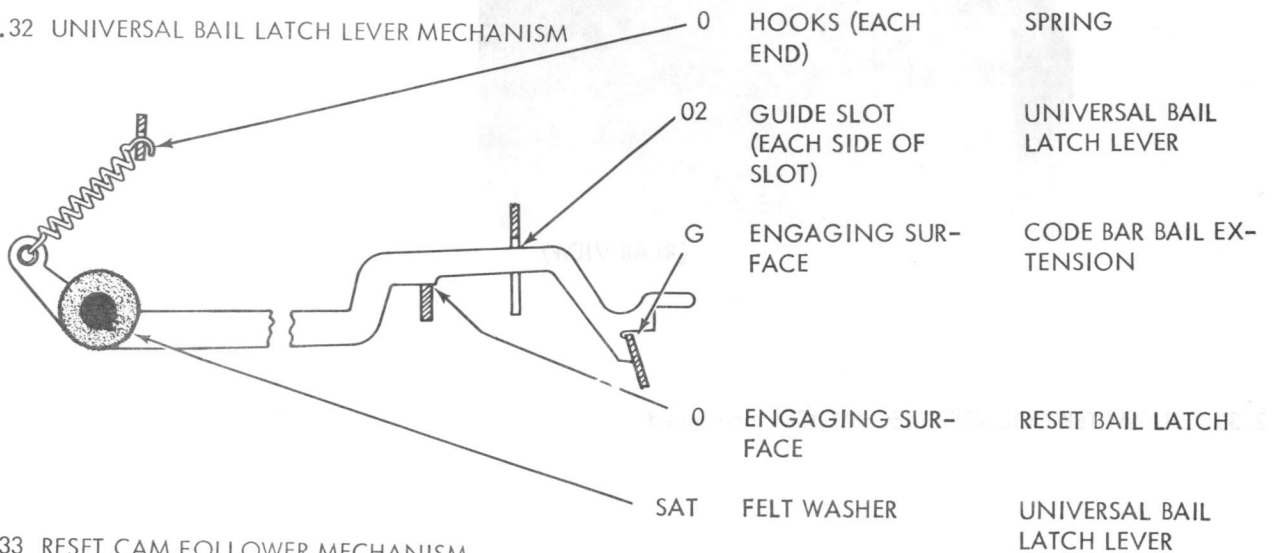

2.33 RESET CAM FOLLOWER MECHANISM

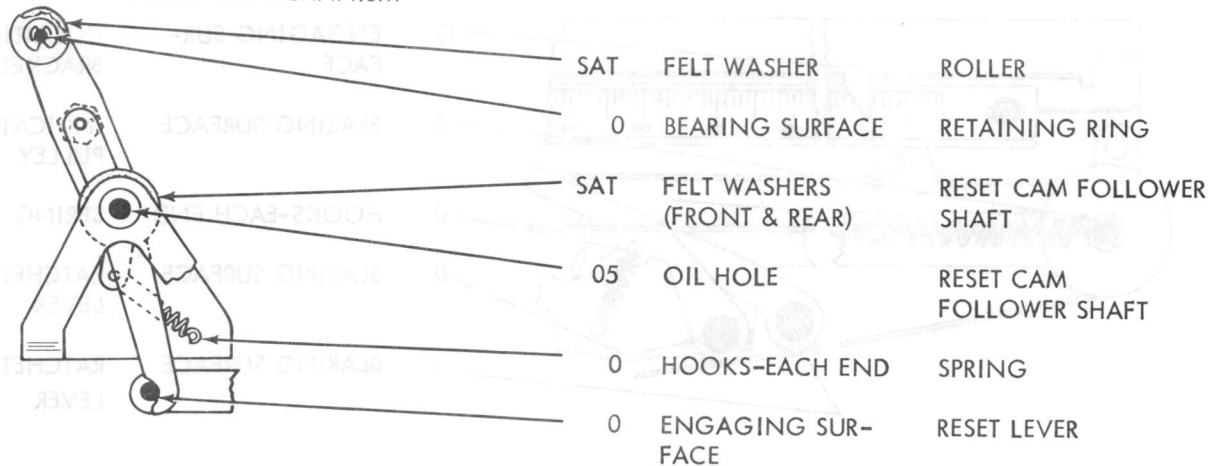

SECTION 573-117-701

2.34 CHARACTER COUNTER AND ELECTRICAL LINE BREAK MECHANISMS  
 NOTE: REST PERFORATOR TRANSMITTER IN UPRIGHT POSITION

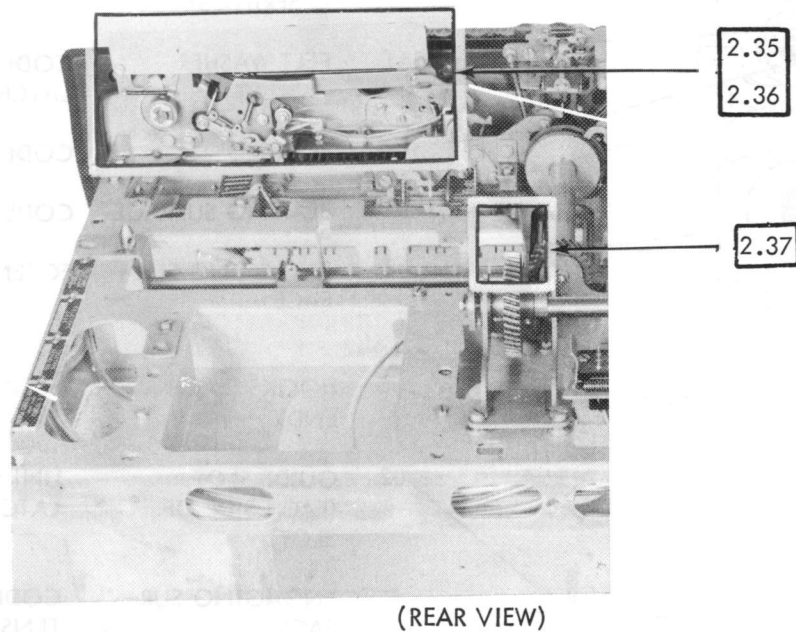

2.35 CHARACTER COUNTER MECHANISM continued

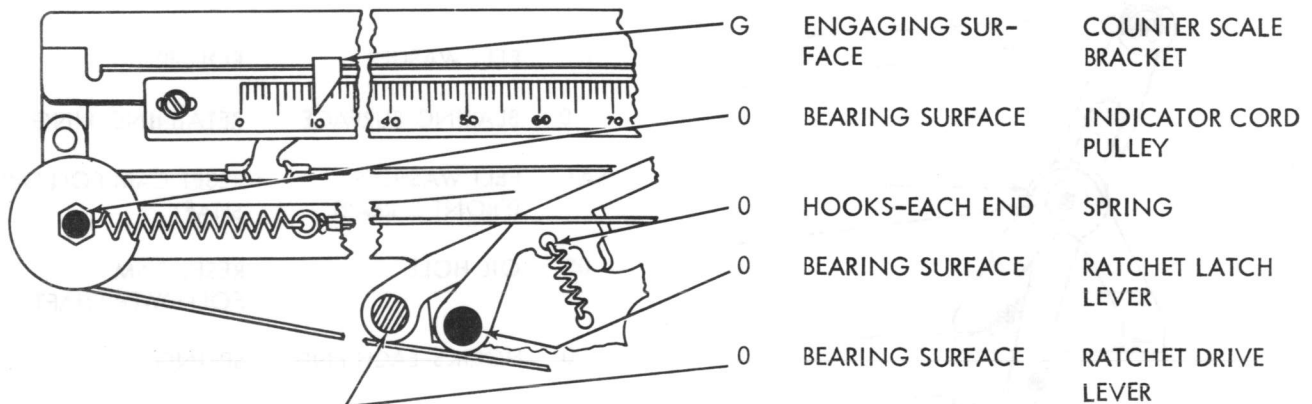

2.36 CHARACTER COUNTER MECHANISM continued

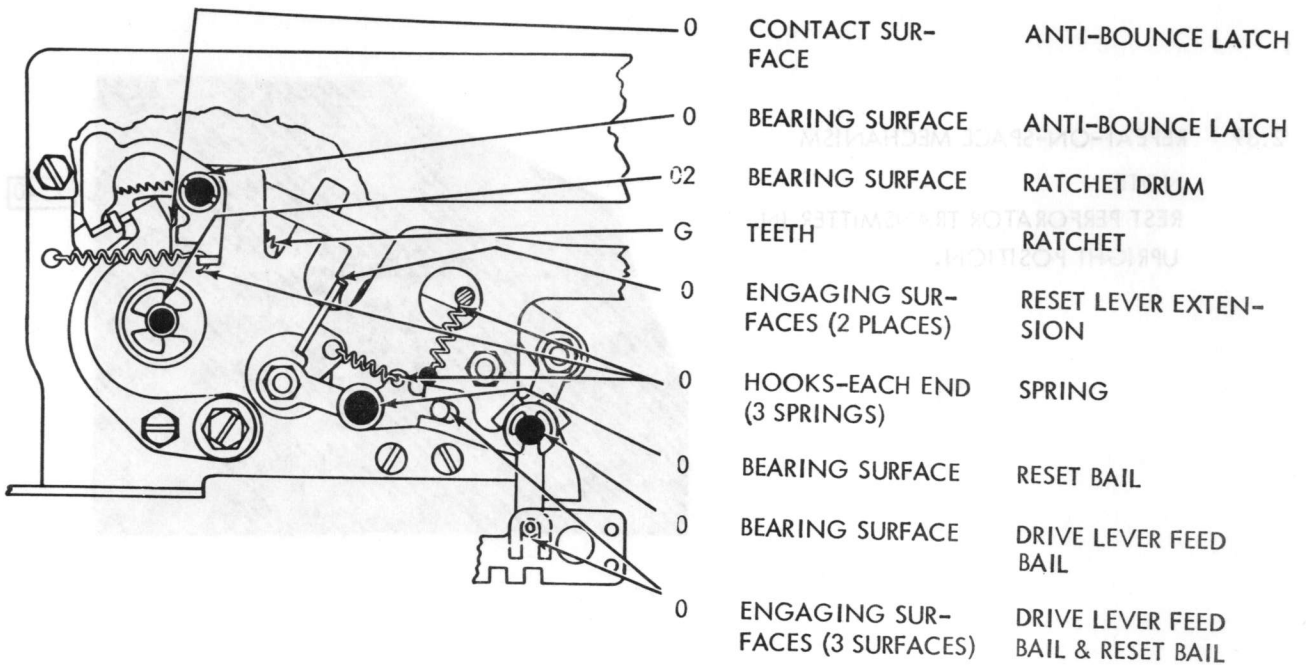

2.37 ELECTRICAL LINE BREAK MECHANISM

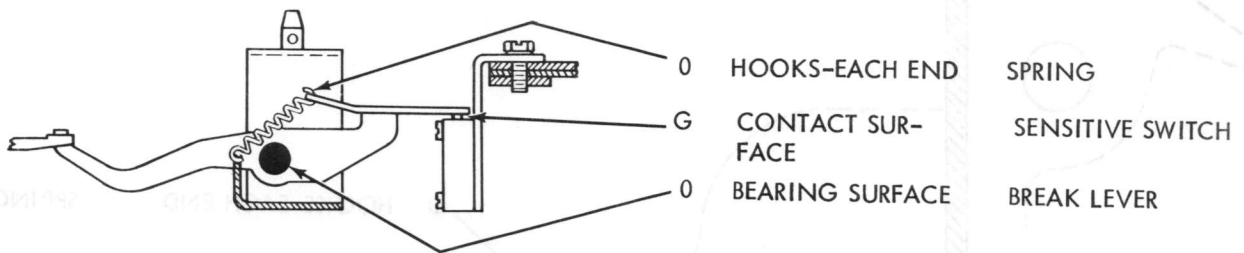

2.38 LOCAL PAPER FEED-OUT MECHANISM

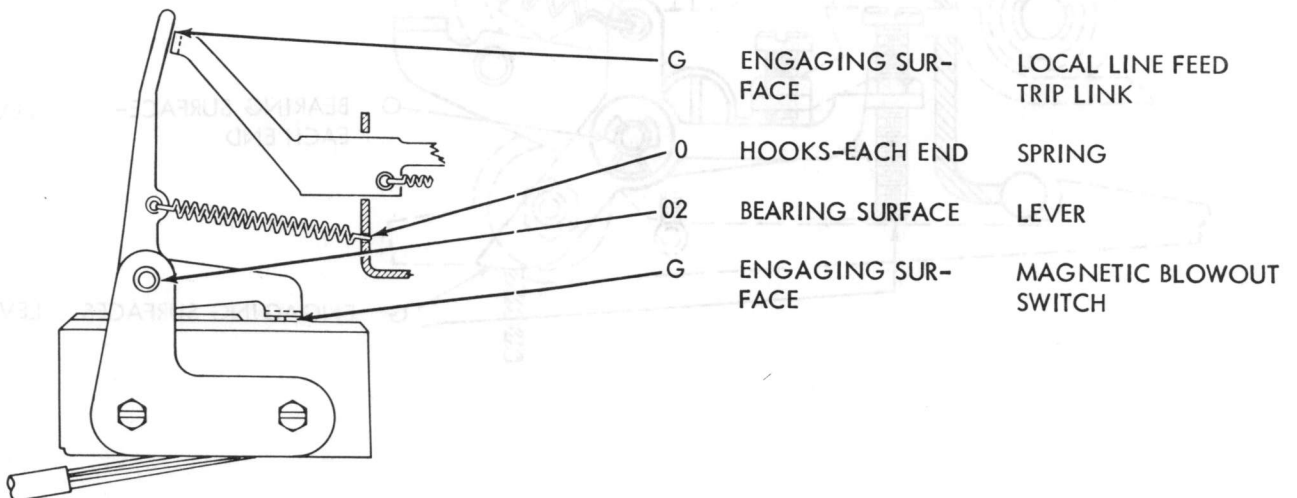

2.39 REPEAT-ON-SPACE MECHANISM

NOTE:  
REST PERFORATOR TRANSMITTER IN UPRIGHT POSITION.

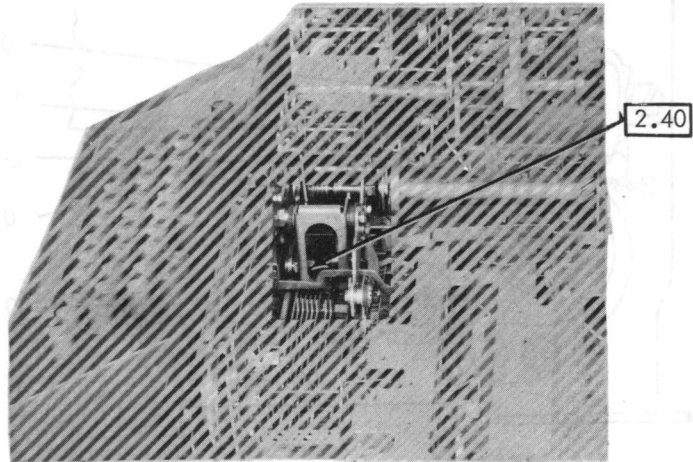

2.40 REPEAT-ON-SPACE

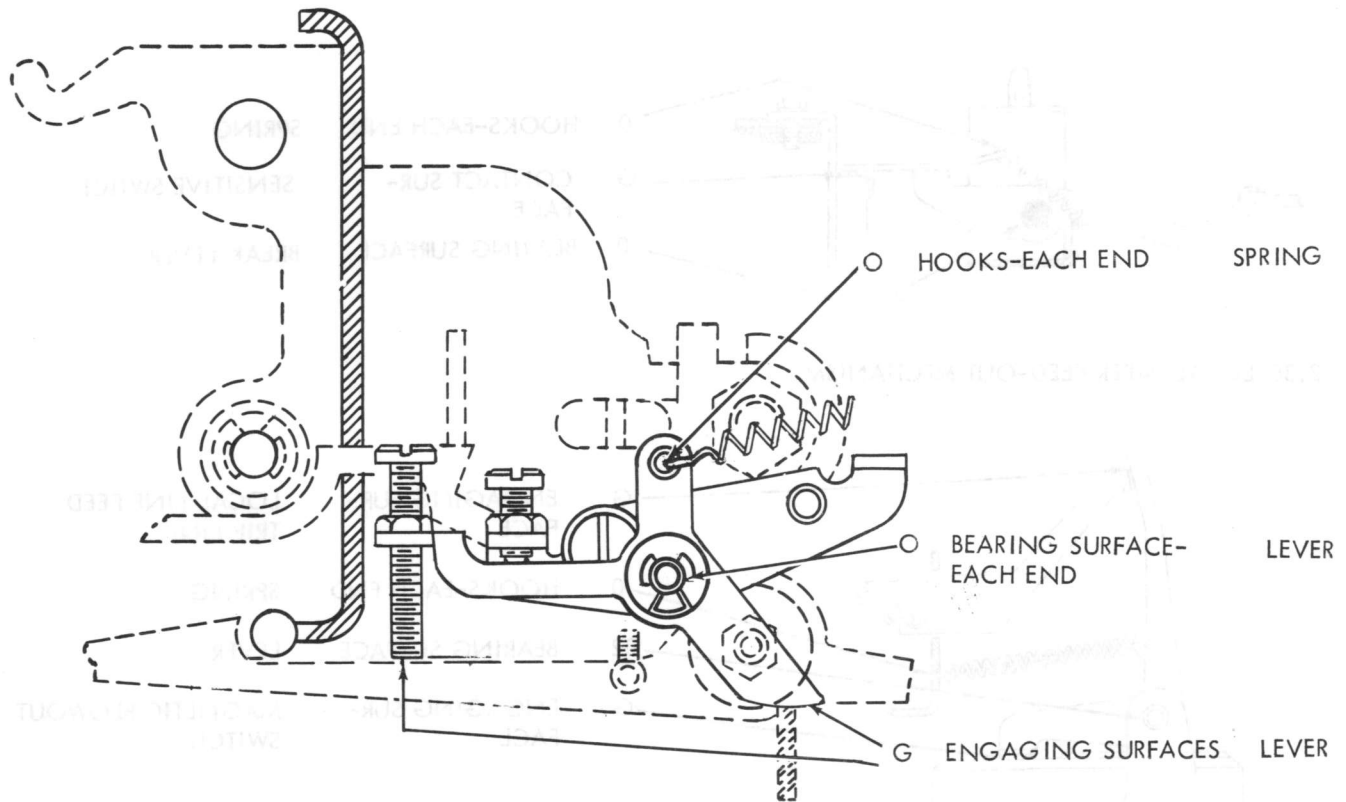



2.41 SYNCHRONOUS PULSE

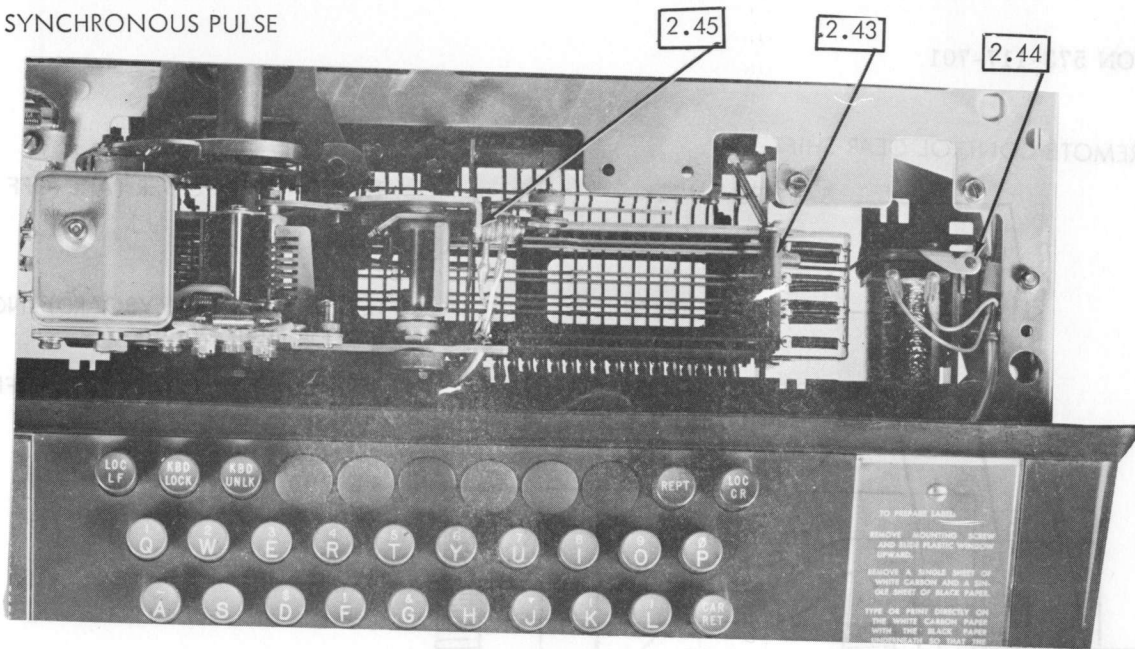

FRONT

2.42 CODE BAR GUIDE

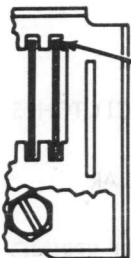

○ GUIDE SLOTS (LEFT, RIGHT, TOP AND BOTTOM)

2.43 SYNCHRONOUS PULSED  
MAGNET MECHANISM

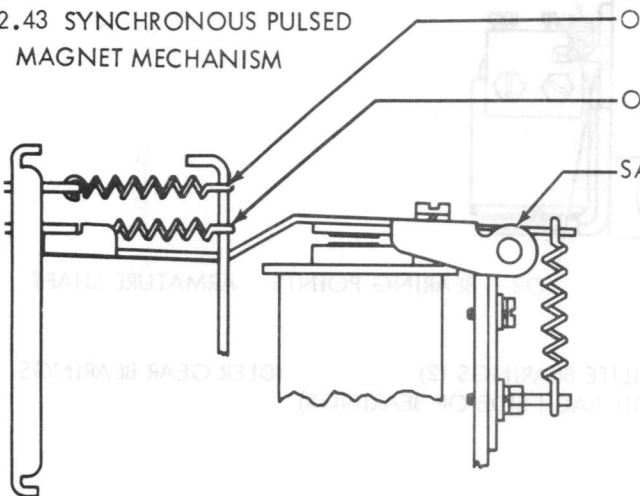

○ HOOKS-EACH END UNIVERSAL CODE BAR SPRING

○ HOOKS-EACH END CLUTCH TRIP BAR SPRING

SAT FELT WASHERS ARMATURE-PIVOT

2.44 CONTACT SWINGER

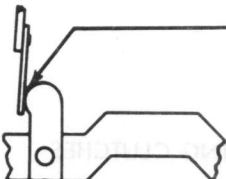

G ENGAGING SURFACE

SECTION 573-117-701

2.45 REMOTE CONTROL GEAR SHIFT

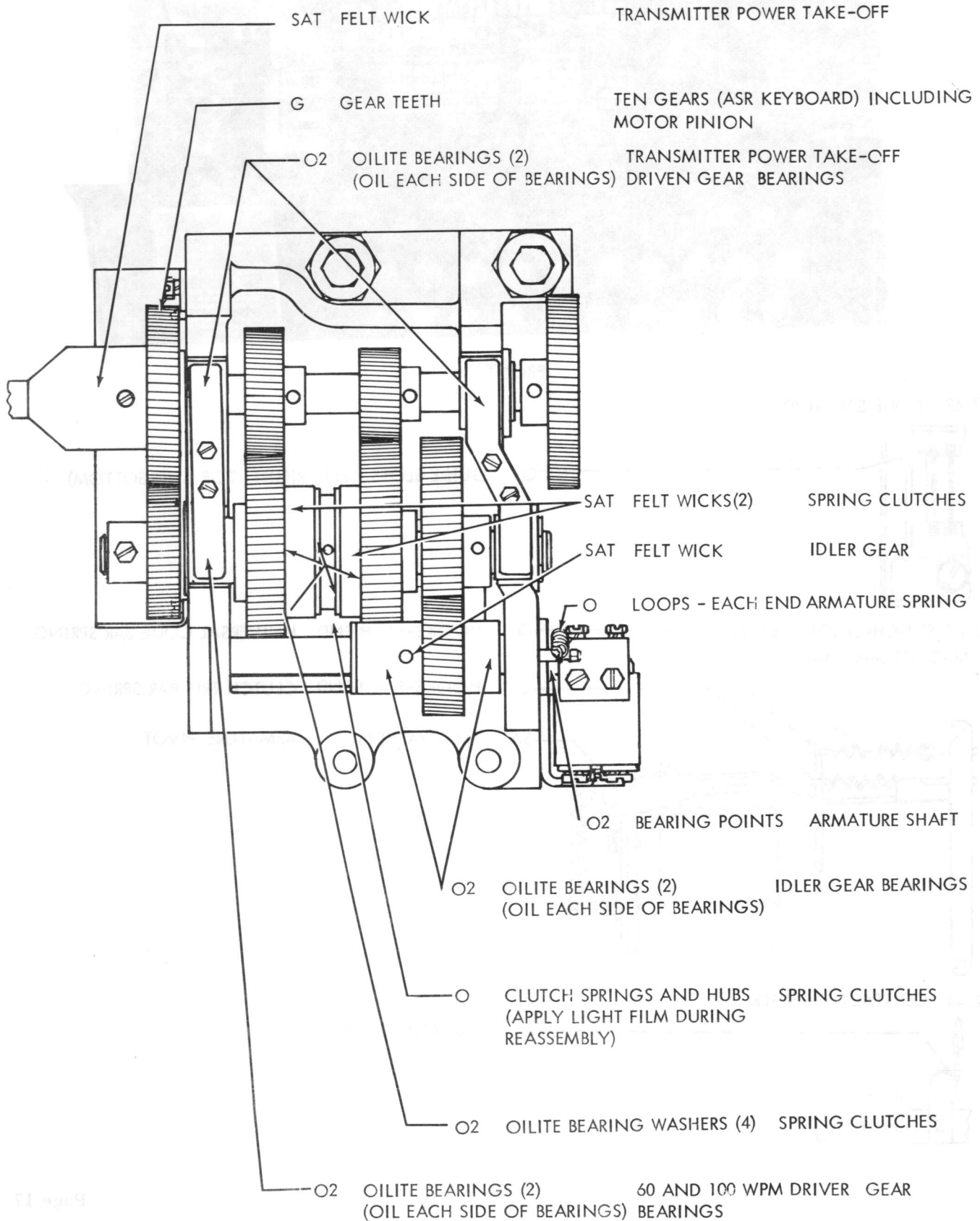

2.46 TIME DELAY MECHANISM

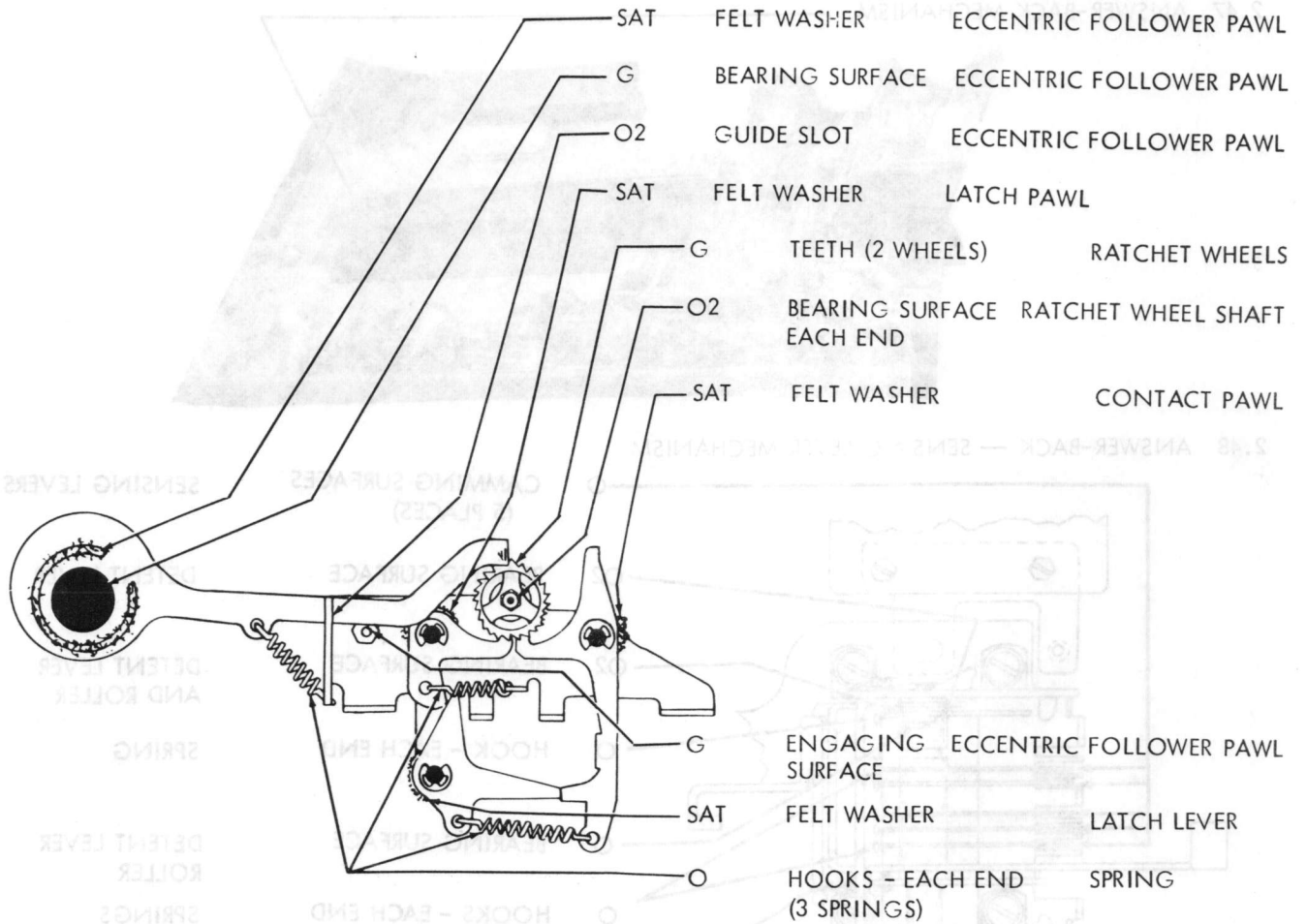

2.47 ANSWER-BACK MECHANISM

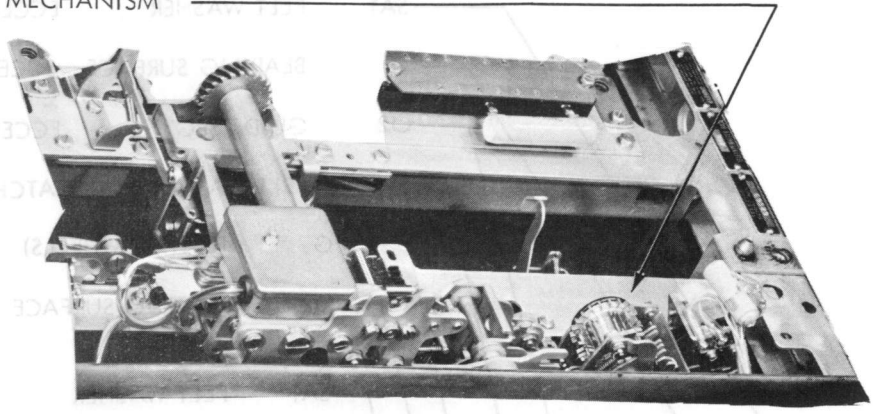

2.48 ANSWER-BACK — SENSING LEVER MECHANISM

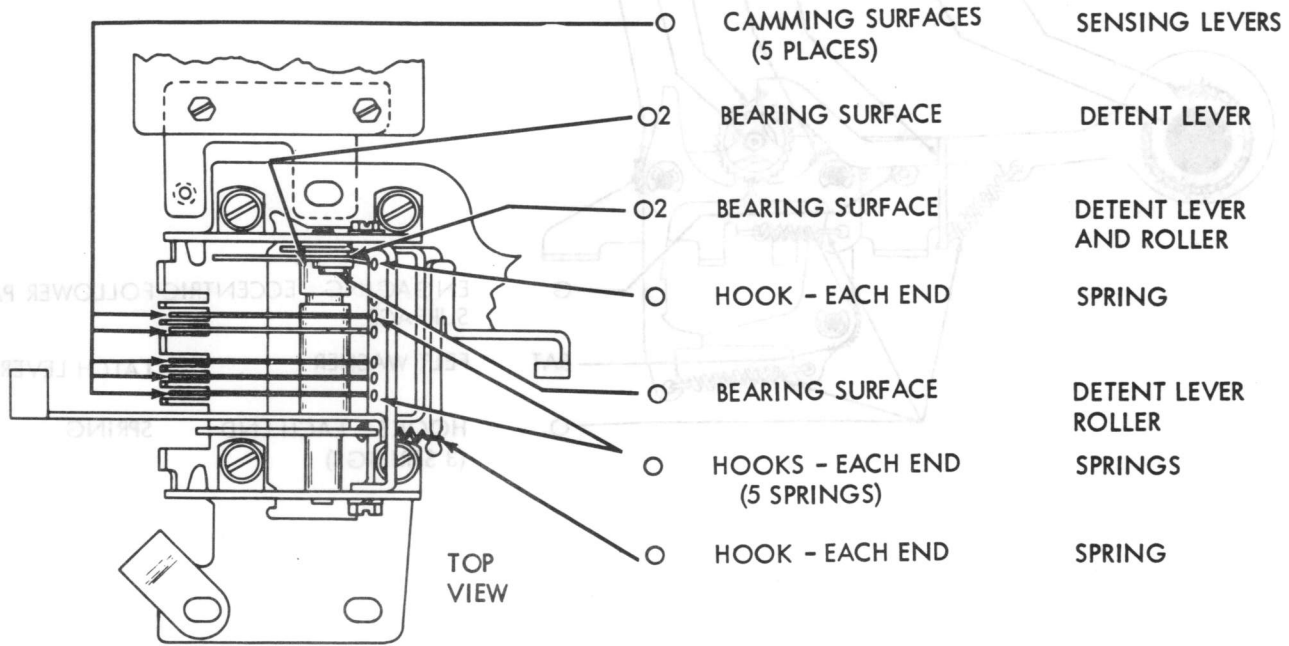

2.49 ANSWER-BACK — ARMATURE MECHANISM

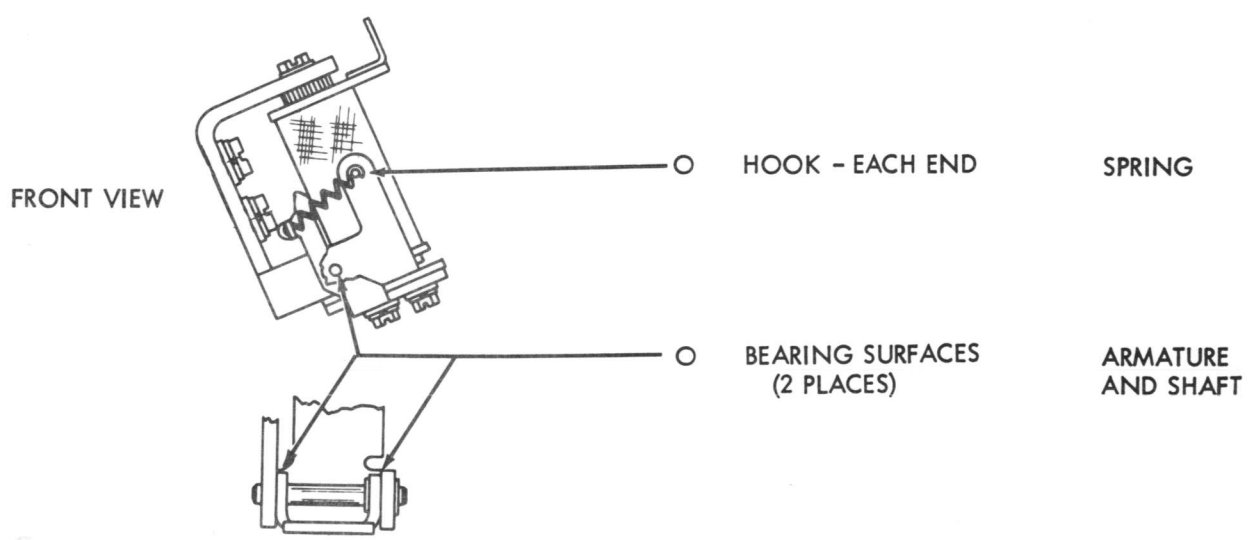

2.50 ANSWER-BACK — STOP LEVER

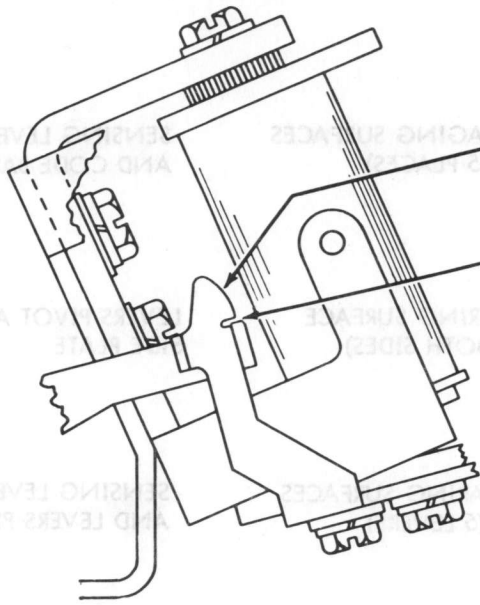

CONTACTING SURFACE LATCH AND STOP LEVER

LATCHING SURFACE LATCH AND STOP LEVER

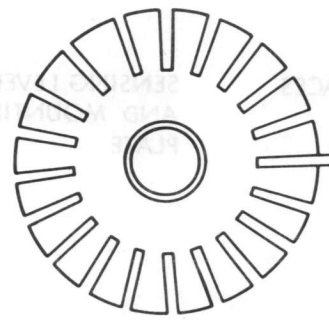

(FRONT VIEW)

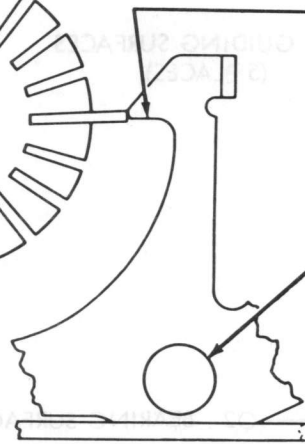

CAMMING SURFACE STOP LEVER

BEARING SURFACE (2 PLACES) STOP LEVER AND LEVER PIVOT

SECTION 573-117-701

2.51 ANSWER-BACK — CODE BARS AND SENSING LEVERS

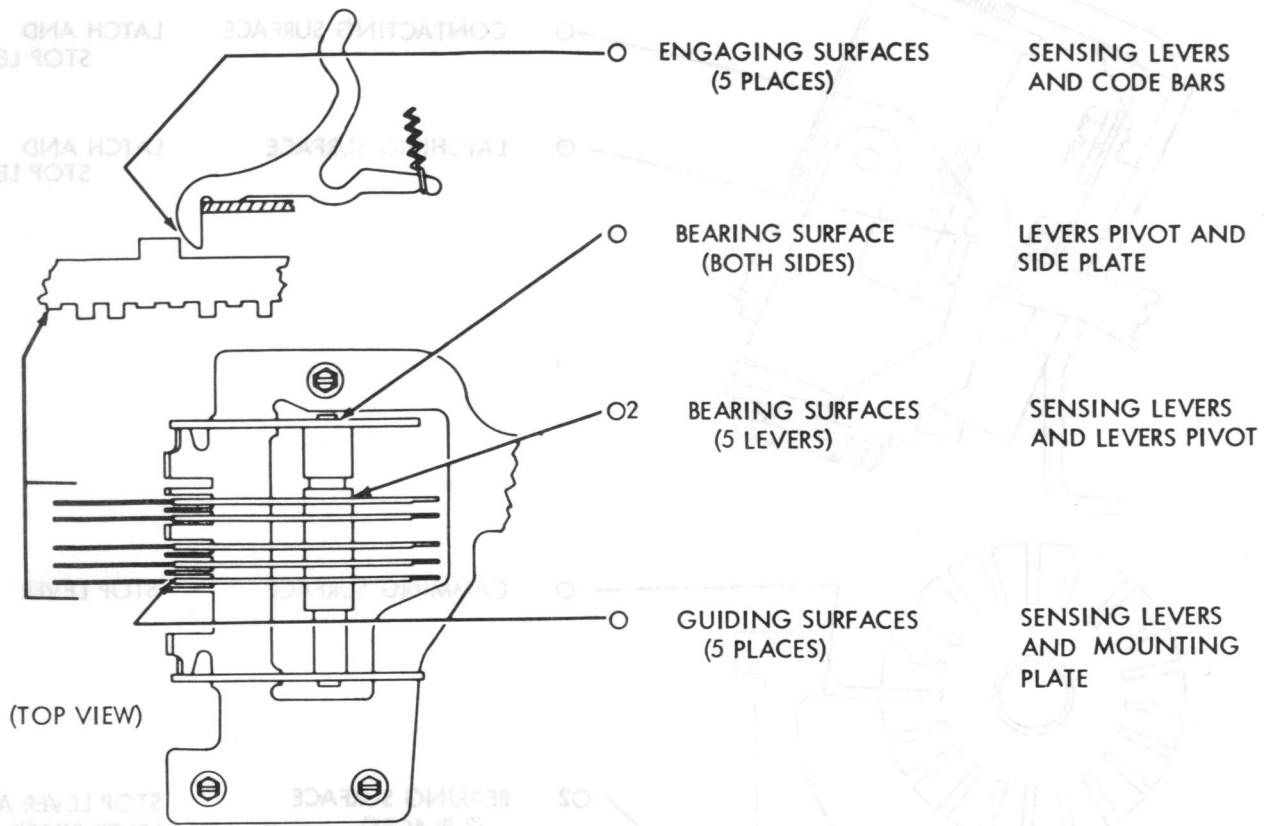

2.52 ANSWER-BACK — DRIVING MECHANISM

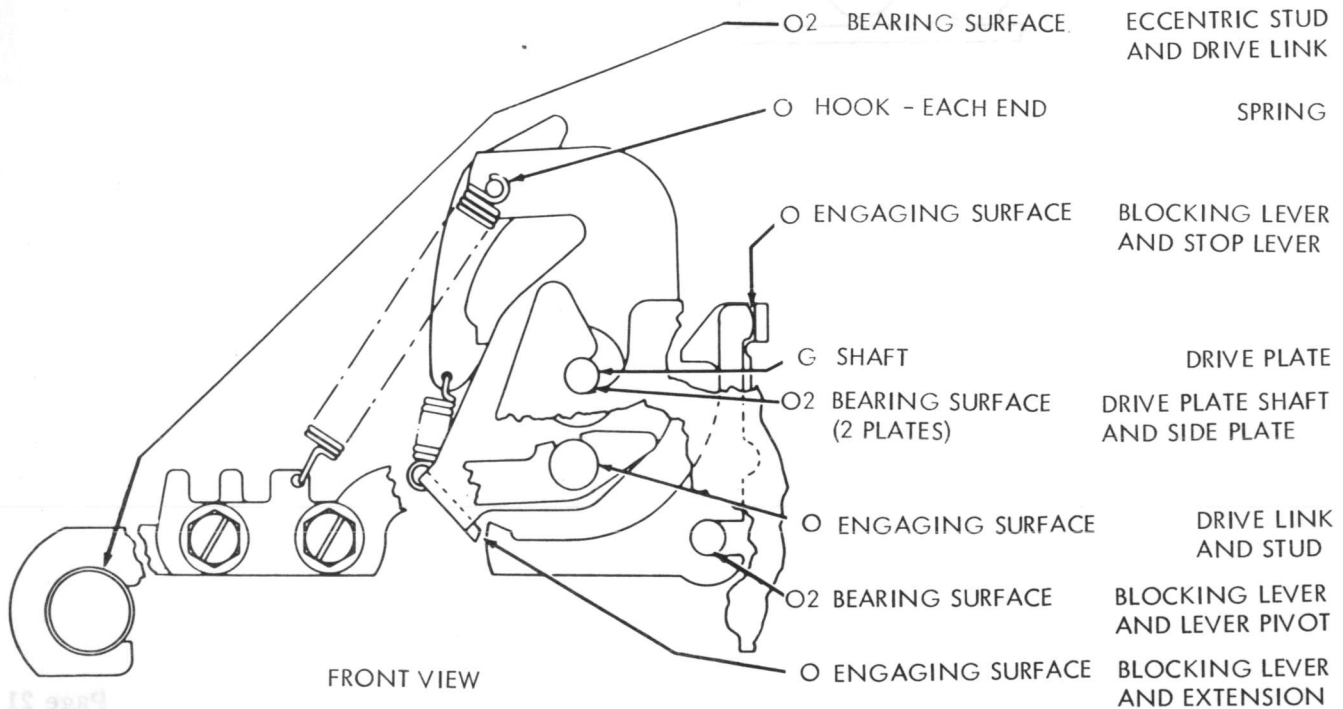

2.53 ANSWER-BACK — STEPPING PAWL

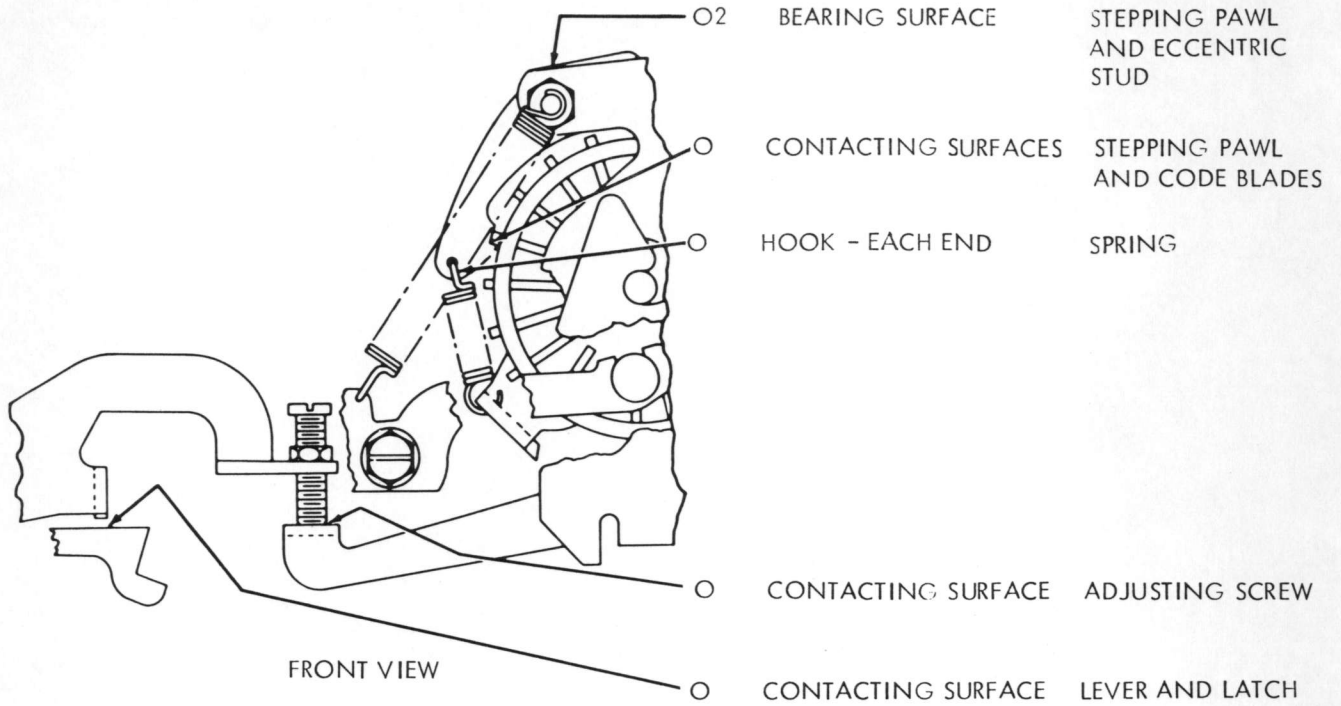

2.54 ANSWER-BACK — KEYBOARD LOCK BAIL MECHANISM

