

ORDER

AAC1000
6170.6A

Eq 11010-3
1050-1

MAINTENANCE OF DATA-HANDLING TERMINAL
EQUIPMENT (TELETYPEWRITER)



FEB 28 14 24 Z 79
AAC-1000

December 4, 1978

**DEPARTMENT OF TRANSPORTATION
FEDERAL AVIATION ADMINISTRATION**

Distribution: Selected Airway Facilities Field Offices
A-X(AF)-3; ZAF-604; ZAC-328

Initiated By: AAC-1010

FOREWORD

1. PURPOSE.

This handbook provides guidance and prescribes technical standards and tolerances and procedures applicable to the maintenance and inspection of data-handling terminal (teletypewriter) equipment. It also provides information on special methods and techniques which will enable maintenance personnel to achieve optimum performance from the equipment. This information augments information available in instruction books and other directives and complements Order 6000.15A, General Maintenance Handbook for Airway Facilities.

2. DISTRIBUTION.

This directive is distributed to selected offices and services within Washington headquarters, NAFEC, and the Aeronautical Center; to branch level within the regional Airway Facilities divisions; and to Airway Facilities field offices having WMSC, BDIS.

3. CANCELLATION.

Order 6170.6, Maintenance of Teletypewriter Terminal Equipment, is cancelled.

4. MAJOR CHANGES.

This revision provides:

a. A glossary of data communications and equipment terms.

b. Description of the Mode V application of the TSEC/KG-13 COMSEC equipment.

c. Description of the proposed National Airspace Data Interchange Network (NADIN).

d. A technical performance record for data-handling terminal equipment (teletypewriter), FAA Form 6170-1.

e. Maintenance information for the line switching unit, Model TSU-10.

f. Deletion of obsolete system application data, including references to international aeronautical telecommunication switching centers (IATSC) at Guam, Wake Island, and American Samoa.

g. Information on modern telecommunication codes, such as the American Standard Code for information Interchange (ASCII) and other machine languages.

h. Revised standards, tolerances, and periodic maintenance schedules.

i. Improved performance test procedures for terminal equipment.

j. Additional appendixes listing publications and drawings for M35 and M37 teletypewriters.

k. Maintenance information for M35 and M37 teletypewriters.

5. MAINTENANCE AND MODIFICATION POLICY.

* a. Order 6000.15A and this handbook shall be consulted and used together by the maintenance * technician in all duties and activities for the maintenance of teletypewriter terminal equipment. These documents shall be considered collectively as the single official source of maintenance policy and * direction authorized by the Systems Maintenance Service. *

b. Order 6032.1A, Modification to Ground Facilities, Systems, and Equipment in the National Airspace System, contains comprehensive policy and direction concerning the development, authorization, implementation, and recording of modifications to facilities, systems, and equipment in commissioned status. It supersedes all instructions published in earlier editions of maintenance technical handbooks and related directives.

6. FORMS LISTING.

FAA Form 6170.1, Technical Performance Record – Data-Handling Terminal Equipment (Teletypewriter), NSN 0052-00-873-5000, Unit of Issue: PD (50).

* Expedited Clearance Procedures for Airway Facilities Maintenance Directives. Users are encouraged to submit recommendations for improvement. *

◦ 7. RECOMMENDATIONS FOR IMPROVEMENT.

Preaddressed comment sheets are provided at the back of this handbook in accordance with Order 1320.40B, *

by: Warren C. Sharp

WARREN C. SHARP
Director, Airway Facilities Service

(Page revised 12/28/89 by CHG 2)

TABLE OF CONTENTS

Chapter 1. GENERAL INFORMATION AND REQUIREMENTS

<i>Paragraph</i>	<i>Page</i>
1. Objective.....	1
2. Scope and Coverage.....	1
3. Trademark "Teletype".....	1
4. Coordination.....	-1
5. Equipment Guarantee.....	1
6. Waivers.....	1
7. Serving Company Line Service.....	2
8. Standardization.....	2
9. Ground Rules.....	2
10. Extension of Leased Teletypewriter Services.....	2
11. Certification Requirements.....	2
12. Service Interruptions.....	2
13. Reporting Excessive Line Distortion.....	2
14.-19. Reserved.	

Chapter 2. TECHNICAL CHARACTERISTICS

20. Purpose or Function.....	3
------------------------------	---

Section 1. SYSTEM APPLICATIONS

21. Service B.....	3
22. Weather Teletypewriter Communications System.....	4
23. Aeronautical Fixed Telecommunications Network (AFTN).....	4
24. National Airspace Data Interchange Network (NADIN).....	4
25. Automatic Meteorological Observing Station (AMOS).....	4
26. FAA COMSEC.....	6
27.-29. Reserved.	

Section 2. EQUIPMENT DESCRIPTION

30. General.....	10
31. Data-Handling Terminal Sets.....	10
32. Summary of M28 Teletypewriter Technical Characteristics.....	15
33. Summary of M35 Teletypewriter Technical Characteristics.....	16
34. Summary of M37 Teletypewriter Technical Characteristics.....	17
35.-39. Reserved.	

**Section 3. DATA CODING, SELECTIVE SIGNALING,
AND SIGNAL DISTORTION**

40. General.....	17
------------------	----

<i>Paragraph</i>	Subsection 1. . BAUDOT CODING	<i>Page</i>
41. Start-Stop Telegraphy.....		18
42.-44. Reserved.		
	Subsection 2. ASCII, EBCDIC, AND ARQ CODING	
45. General.....		20
46. The ASCII Code.....		20
47. The EBCDIC Code.....		22
48. The Moore ARQ Code.....		22
49. Reserved.		
	Subsection 3. SELECTIVE SIGNALING	
50. Selective Calling.....		24
51. Operation of a Printer Function.....		28
52. Sequential Selection of a Function.....		28
53. Control of Remote Apparatus.....		29
54. Message Coding.....		29
55. Operation of Relay Control Group.....		30
56.-59. Reserved.		
	Subsection 4. SIGNALS, DISTORTION, AND DISTORTION ANALYSIS	
60. Bauds and Bits.....		31
61. Signaling Speed.....		32
62. Signal Distortion.....		32
63. Distortion Analysis Equipment.....		33
64.-69. Reserved.		
	Chapter 3. STANDARDS AND TOLERANCES	
70. General.....		37
71. Receiving Equipment.....		37
72. Transmitting Equipment.....		37
73. Ancillary and Miscellaneous Equipment.....		37
74.-79. Reserved.		
	Chapter 4. PERIODIC MAINTENANCE	
80. General.....		39
	Section 1. PERFORMANCE CHECKS	
81. Bimonthly (60 Days).....		40
82.-89. Reserved.		
	Section 2. OTHER MAINTENANCE TASKS	
	Subsection 1. M28, M35, and M37 EQUIPMENT	
90. Monthly.....		40
91. Bimonthly (60 Days).....		41

Paragraph

Page

92. Quarterly.....	42
93. Semiannually.....	42
94. Two-Year Intervals.....	43
95. Eight-Year Intervals.....	43
96.-97. Reserved.	

Subsection 2. ANCILLARY AND MISCELLANEOUS EQUIPMENT

98. Early Models and Ancillary Equipment.....	43
99. Reserved.	

Chapter 5. MAINTENANCE PROCEDURES

100. General.....	45
101. Test Equipment.....	45

Section 1. PERFORMANCE CHECK PROCEDURES

102. FAA Form 6170-1 Entries.....	47
103. Receiving Equipment Distortion Tolerance Test.....	47
104. Transmitting Equipment Distortion Test.....	47
105. Serving Company or FAA-Owned Line Tests.....	48
106.-109. Reserved.	

Section 2. OTHER MAINTENANCE TASK PROCEDURES

110. Cleaning, Inspection, and Lubrication of M28, M35, and M37 Printers.....	48
111. Relay Adjustments.....	49
* 112. Calibration of TELECOM Switching Unit, Model TSU-10.....	52-1
113. Inspection and Cleaning of APULS Equipment.....	52-4
114. Lubrication of Stepping Switches and Latching Relays in APULS Equipment.....	52-4
115. Adjustment Procedure for APULS Equipment.....	52-7
116.-119. Reserved.	

Section 3. SPECIAL MAINTENANCE PROCEDURES

120. Test and Adjustment of Relay 33RY.....	53
121. Code Bar to Function Time Alignment.....	57
122. ASR Checkout Procedures.....	58
123. Printer Troubleshooting Procedure.....	58
124. Transmitter-Distributor Contact Adjustment Using DTS-531P.....	60
125. Calibration of DTS-531P for 74.2 Baud Rate.....	60
126.-139. Reserved.	

Chapter 6. MISCELLANEOUS

140. Authorized Equipment Modifications.....	63
141. Mercury-Wetted Contact Keying Relays.....	63
142. Guide-Plate Wear.....	63
143. Factors Affecting Printer Mark-Space Currents.....	63
144. Line Switching Unit CA-1696.....	63
145. Teletype Corporation Bulletin Procurement.....	64
146. COMSEC Publications.....	65
147. Teletypewriter Standard Drawing Procurement.....	65

*Paragraph**Page*

Appendix 1. GLOSSARY	1
Appendix 2. M28 TELETYPEWRITER DRAWING INDEX	1
Appendix 3. M35 TELETYPEWRITER DRAWING INDEX	1
Appendix 4. TELETYPE CORPORATION M28, M35, AND M37 EQUIPMENT NOMENCLATURES, BULLETIN SECTIONS, AND NSN'S	1
Section 1. M28 and M37 Equipment	1
Section 2. M37 Equipment	2
Appendix 5. M28 TELETYPEWRITER FUNCTION BOX LAYOUT	1

LIST OF ILLUSTRATIONS*Figure**Page*

2-1. M28 Teletypewriter Terminal Sets.....	3
2-2. NADIN System Configuration (Proposed).....	5
2-3. AMOS 3-70 System.....	6
2-4. AMOS 3-73 System.....	7
2-5. Mode V Asynchronous AUTODIN, TSEC/KW-26C.....	8
2-6. Mode V Synchronous AUTODIN, TSEC/KG-13.....	9
2-7. M28 ASR Subunits.....	13
2-8. M28 Teletypewriter Apparatus Designations.....	14
2-9. Functioning of Baudot Five-Level Code.....	18
2-10. Paper Tape Arrangement of Baudot Five-Level Code.....	19
2-11. ASCII 11-Unit Code Format.....	20
2-12. ASCII Code Functions and Paper Tape Arrangement, Pre-1967.....	21
2-13. Function Box Mechanism.....	26
2-14. Code Bars-to-Function Bar Tines Relationship.....	27
2-15.-2-18. Reserved.	
2-19. DTS-531P Distortion Patterns.....	34
5-1. Sample FAA Form 6170-1.....	46
5-2. BL Relay Adjustment.....	50
5-3. Relay Group Adjustment.....	51
* 5-3A. Calibration Adjustment and Test Point Location, PS-3.....	52-2
5-3B. Calibration Adjustment and Test Point Location, RA-5.....	52-3
5-3C. Stepping Switches K601 and K602, Principal Parts.....	52-6
5-3D. Stepping Switch K901, Principal Parts.....	52-8
5-3E. Crossover Patterns.....	52-8
5-3F. Test Loop Set-Up.....	52-10
5-3G. Relay Adjustment Details.....	52-12
5-3H. Relay Parts Location.....	52-13 *
5-4. Maintenance Adjustments of Relay 33RY.....	54
5-5. Initial Alignment of Relay 33RY.....	55
5-6. Alignment of Function Lever Times to Code Bars.....	56
5-7. "T for Texas" Type Box Check.....	59
5-8. DTS-531P Analyzer Oscillator and Generator Oscillator at Same Baud Rate.....	62
5-9. DTS-531P Analyzer Properly Calibrated.....	62
6-1. FAA Standard Relay Control Group Schematic Diagram.....	64

Table

Page

LIST OF TABLES

Table

Page

2-1.	Comparison of M28, M35, and M37 Teletypewriters.....	11
2-2.	M28, M35, and M37 Apparatus Codes.....	12
2-3.	Definitions of 1967 ASCII Code Symbols.....	22
2-4.	EBCDIC Code Format.....	23
2-5.	Moore ARQ Code Format with Baudot Five-Level Code.....	24
2-6.	Comparison of Signaling Speed by Equipment and Transmission Code.....	32
5-1.	Test Equipment Listing.....	45
* 5-2.	List of Lubricants.....	52-5
5-3.	Polar Relay Adjustment Chart.....	52-11 *

CHAPTER 1. GENERAL INFORMATION AND REQUIREMENTS

1. OBJECTIVE.

This handbook provides the necessary guidance to * be used in conjunction with information available in other orders and directives for the proper maintenance * of data-handling terminal equipment (teletypewriter).

2. SCOPE AND COVERAGE.

This order provides maintenance information and instructions for three data-handling equipment terminals, known as the Model 28 (M28), Model 35 (M35), and Model 37 (M37) teletypewriter sets. The three are manufactured by the Teletype Corporation, Skokie, Illinois. Also included are maintenance information and instructions for ancillary equipment, such as line switching equipment, relay control groups, electrical service units; and there are brief descriptions of major system applications of the equipment. Standard drawings for the terminals, and a complete list of publications issued by the manufacturer are contained in the appendixes. Appendix 1 is a glossary of most telecommunication terms used in discussions of teletypewriters and other data-handling terminal equipment.

3. TRADEMARK "TELETYPE."

"Teletype" is a registered trademark belonging to the Teletype Corporation. "Teletype" shall be capitalized and always used as a company identification. Publications or correspondence originating within the agency pertaining to data-handling equipment will be referred to as "data-handling equipment," "teletypewriter" equipment, or by the individual unit name, such as "M28/RO" or "M28/ASR," etc.

4. COORDINATION.

a. Any maintenance operation or activity performed on data-handling equipment that may affect normal operating procedures shall be coordinated with the user of the system, such as Air Traffic management or military operations personnel. Line relays may be removed only when the service equipment is disconnected from the line circuit or when the equipment is turned off.

b. Equipment removal, operations, or shutdown that may affect the long-line service shall be coordinated with the associated serving company or organi-

zation, such as the telephone company, Western Union Company, or the military services.

5. EQUIPMENT GUARANTEE.

a. The Teletype Corporation places a 90-day (from shipping date) no-cost warranty on all parts and components. The Teletype Corporation has an agreement with the FAA to mark each box or carton with the shipping date immediately prior to pickup at the factory. FAA will use this date to compute the guarantee period.. Request for free replacement parts which fall outside the guarantee period shall be discontinued. **ANY MODIFICATION OR REPAIRS PERFORMED BY FAA PERSONNEL ON DAMAGED PARTS OR COMPONENTS WILL AUTOMATICALLY VOID THE WARRANTY.**

b. Summarizing the agreement between the Teletype Corporation and the FAA, the following guarantee clause applies to equipment purchased from the Teletype Corporation:

"All items furnished on this contract shall be guaranteed to function properly when installed, operated without abuse, and maintained in accordance with the contractor's instructions. The contractor shall agree to furnish the Government transportation charges prepaid, a new part for, or repair without charge, all parts which fail to give satisfactory service due to defects in material or workmanship provided that parts show defects and the contractor is notified thereof, in writing, 90 days after delivery of apparatus, and such parts are returned to the contractor at Chicago, delivery charges collect, and further provided that contractor's examination of such parts confirm Government's claim."

6. WAIVERS.

Where a region cannot comply with one or more of the standards and tolerances and/or procedures prescribed herein at a particular location, a request for a waiver shall be submitted as soon as practicable to the Airway Facilities Service. The request must fully describe the circumstances and contain justification for the waiver. Refer to Order 6000.20B, Waiver of Criteria for Establishment and Maintenance of Airway Facilities.

7. SERVING COMPANY LINE SERVICE.

All agency data-handling switching and system interconnections discussed in this order are designed to utilize neutral or polar operation. Operation of the serving company's portion of the system is at their discretion; however, the extension from the FAA demarcation terminal is always required to be neutral, except at the RS-232 interface which is a polar connection.

8. STANDARDIZATION.

It is the policy of the agency that all data-handling terminal equipment, used for a specific purpose, be standardized both electrically and mechanically. To this end, modification instructions and kits for weather printers have been issued. Equipment items overhauled at the depot are now configured to FAA standards. Information regarding the standard configuration is contained in this order. New and/or rebuilt installations will be designed for the FAA standard equipments. The standardization program makes it possible to interchange equipment between locations and engage in transactions with the FAA Depot without the necessity of reconfiguring the equipments.

9. GROUND RULES.

The latest edition of Order 4441.9, Practices Concerning Leased Telecommunications Services, provides uniform guidelines covering the standardization and modernization of leased telecommunication services and serving companies. In quarters other than FAA, the ground rules are applicable only at the demarcation cabinet and to the installation on the equipment side of the demarcation strip.

10. EXTENSION OF LEASED TELETYPEWRITER SERVICES.

The telephone company has found at some locations that two "drops" were being served from one telephone company local channel. The additional exten-

sion had been wired in from the FAA demarcation strip by Airway Facilities personnel. The Washington office has been notified by AT&T that while tariff imposes no limitation on the number of customer-owned-and-maintained (COAM) machines connected to a circuit at one location, it does provide that any extension of a circuit to a separate location must be installed by the telephone company. Some service companies are providing a replacement solid-state power supply which will limit the number of COAM machines to one or two.

11. CERTIFICATION REQUIREMENTS.

There are no certification requirements for data-handling terminal equipment.

12. SERVICE INTERRUPTIONS.

Service interruptions of less than 1 minute's duration ordinarily will not be reported to the serving company's serving test center (STC) unless the interruption occurs several times during an 8-hour watch. Garbling, line running open, or similar interruptions, which occur frequently or continue for periods in excess of 1 minute should be reported to the serving company's STC. Operating personnel should be reasonably certain that the trouble is not due to malfunctioning of FAA equipment before notifying the serving company.

13. REPORTING EXCESSIVE LINE DISTORTION.

The acceptable distortion level received from the long lines can vary from 15 to 20 percent according to facility and serving company. When it is determined that the line has exceeded this mutually accepted level, it is the responsibility of the Airway Facilities sector manager or his representative to notify the serving company.

14.-19. RESERVED.

CHAPTER 2. TECHNICAL CHARACTERISTICS

20. PURPOSE OR FUNCTION.

Data-handling terminal equipment is used in a variety of communication systems for flight planning, collection and dissemination of meteorological data, and coordination of air traffic movement. The follow-

ing paragraphs include a brief description of the equipment and its major system applications. Figure 2-1 shows three basic configurations of the general-purpose communication teletypewriter, the Teletype Corporation Model 28 (M28).

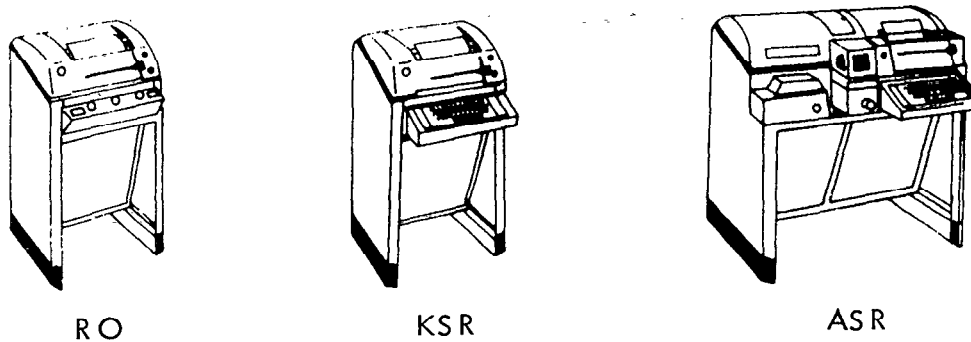

Figure 2-1. M28 Teletypewriter Terminal Sets

Section 1. SYSTEM APPLICATIONS

21. SERVICE B.

Service B provides record communications among all FAA operating facilities, headquarters, and regions as well as associated aviation users. It consists of two transcontinental networks: a major network known as area B, or alternatively, automated service B data interchange system (A-BDIS), and a minor network called center B. In addition, there is a set of circuits referred to as utility B, for high volume users, military and air carriers. Although computer B is a part of service B, it is actually a subsystem of the NAS stage A enroute system (IBM 9020). It is a hybrid composed of the flight data entry and printout (FDEP) equipment and flight data distribution system (FDDS) servicing the towers and IFR rooms. Service B was implemented to expedite the transfer of flight planning, movement and notification information, and aviation and air traffic control supporting information.

a. **Area B.** Area B network consists primarily of low-speed (100wpm) channels used for the distribution and collection of data from terminals at flight service stations (FSS's), combined stations and towers (CS/T's), and air route traffic control centers (ARTC-

C's). Automatic relay of the message is provided by computers located at the National Communication Center (NATCOM) and the Kansas City ARTCC. Relay is also made to the Aeronautical Fixed Telecommunications Network (AFTN). The A-BDIS computers are connected to AFTN via a 2400 bits per second (bps) link. Other medium-speed links extend to the Meteorological and Aeronautical Presentation Subsystem (MAPS) at Washington FSS (collocated with Washington ARTCC) and to the Automated Weather and NOTAM System (AWANS) at Atlanta, Georgia, and Indianapolis, Indiana.

b. **Center B.** The center B system is an intercontinental network interconnecting all ARTCC's. The ARTCC's are connected to the AFTN switch at Kansas City via five separate circuits. The AFTN switch provides the polling and interfacing necessary to the ARTCC communication with AFTN circuits and for area B circuits (BDIS).

c. **Utility B.** The utility system is a combination of those independent circuits formerly called military B and carrier B. It is used to transfer military and com-

mercial carrier IFR flight plans to the center responsible for the area in which the flight originates. There are two different categories of utility B. Category 1 consists of send/receive circuits, polled by automatic program unit-low speed (APULS) with no relay capability between circuits; while category 2 consists of one-way, unpolled point-to-point circuits from base operations and airline dispatch offices.

22. WEATHER TELETYPEWRITER COMMUNICATIONS SYSTEMS.

a. The weather teletypewriter communications system (WTCS) is designed to centralize, consolidate, and automate the message switching functions of the three message services A, C, and O through the establishment of a weather message switching center (WMSC) at Kansas City, Missouri. The circuit control and relay functions of the WMSC are performed automatically by a Phillips DS-714 message/data switching system, which is a computer-directed, store-and-forward communications switch. Its function is to perform all polling, collection, storage, selection, and redistribution of the meteorological and notices to airman (NOTAMS) information handled by the consolidated system. The total consolidation has not been completed.

b. The DS-714 system has a variety of transmission speeds. It will interface with a range of from 100 words per minute (wpm) teletypewriter circuits up to 9600bps data circuits. Currently, the circuits having 2400bps are the fastest in use. It also accepts information in Baudot or USA standard code for information interchange (ASCII) codes at any standard teletypewriter or data interface level.

23. AERONAUTICAL FIXED TELECOMMUNICATIONS NETWORK (AFTN).

a. The present FAA-AFTN network is divided into major areas—the North Atlantic and Caribbean Area, and the Alaskan and Pacific Area. The Alaskan and Pacific Area is served by multiple switching centers at Anchorage, San Francisco, and Honolulu. These centers operate in a semiautomatic or fully automatic mode utilizing punched paper tape or computers.

IATSC	Mode of Operation	Type of System
Anchorage	Fully Automatic	Phillips ES-3
Honolulu	Fully Automatic	Western Union Plan 59A
Kansas City	Computerized, Fully Automatic	Phillips DS-714

b. In 1970, FAA replaced the manual switching centers associated with the North Atlantic and Caribbean Area by an automated central distribution center at Kansas City, Missouri. It is collocated with the WMSC and BDIS relay facilities at the National Communications Center (NATCOM). The AFTN Center is referred to as the International Aeronautical Telecommunications Switching Center (IATSC). Its function is the relay of international meteorological and aeronautical traffic which was originally performed at each of four locations, which now serve as hubs to feed IATSC: New York, Miami, San Juan, and Balboa.

24. NATIONAL AIRSPACE DATA INTERCHANGE NETWORK (NADIN).

a. A national digital communication network to absorb the services and networks described in paragraphs 21 through 23 is programmed. The proposed network is to be controlled by two major switching centers, one at Atlanta, and the other at Salt Lake City, adjacent to the air route traffic control centers (ARTCC). The major centers will handle a network of "concentrators," located at each ARTCC. The centers will feed both dedicated and multipoint data-handling circuits in the continental United States (CONUS), and separate tributary circuits to Honolulu, Anchorage, and San Juan.

b. The data-handling rates between the switching centers and concentrators is to be 2400/4800 synchronous bps. Between the two switching centers, the data rate is to be 9600 synchronous bps. Local circuits handled by the concentrators, such as Area B, AFTN, utility B, and the like will range from 50 to 1200 bauds, asynchronous. The ARTCC concentrator will interface with the local en route 9020 computer system at 9600bps, asynchronous serial. The three communication codes to be used are the extended binary coded decimal for information code (EBCDIC) between the 9020 and the concentrator, the ASCII on the weather message circuits, and the Baudot teletypewriter code on AFTN, area B, utility B, and similar circuits, principally using the M28 teletypewriter. See figure 2-2.

25. AUTOMATIC METEOROLOGICAL OBSERVING STATION (AMOS).

a. The National Weather Service (NWS) operates and maintains automatic meteorological observing stations at both manned and unmanned weather collecting sites throughout the country. These facilities continuously monitor the weather conditions (temperature, dew point, wind direction, wind speed, station pressure, and precipitation). It is the responsibility of the

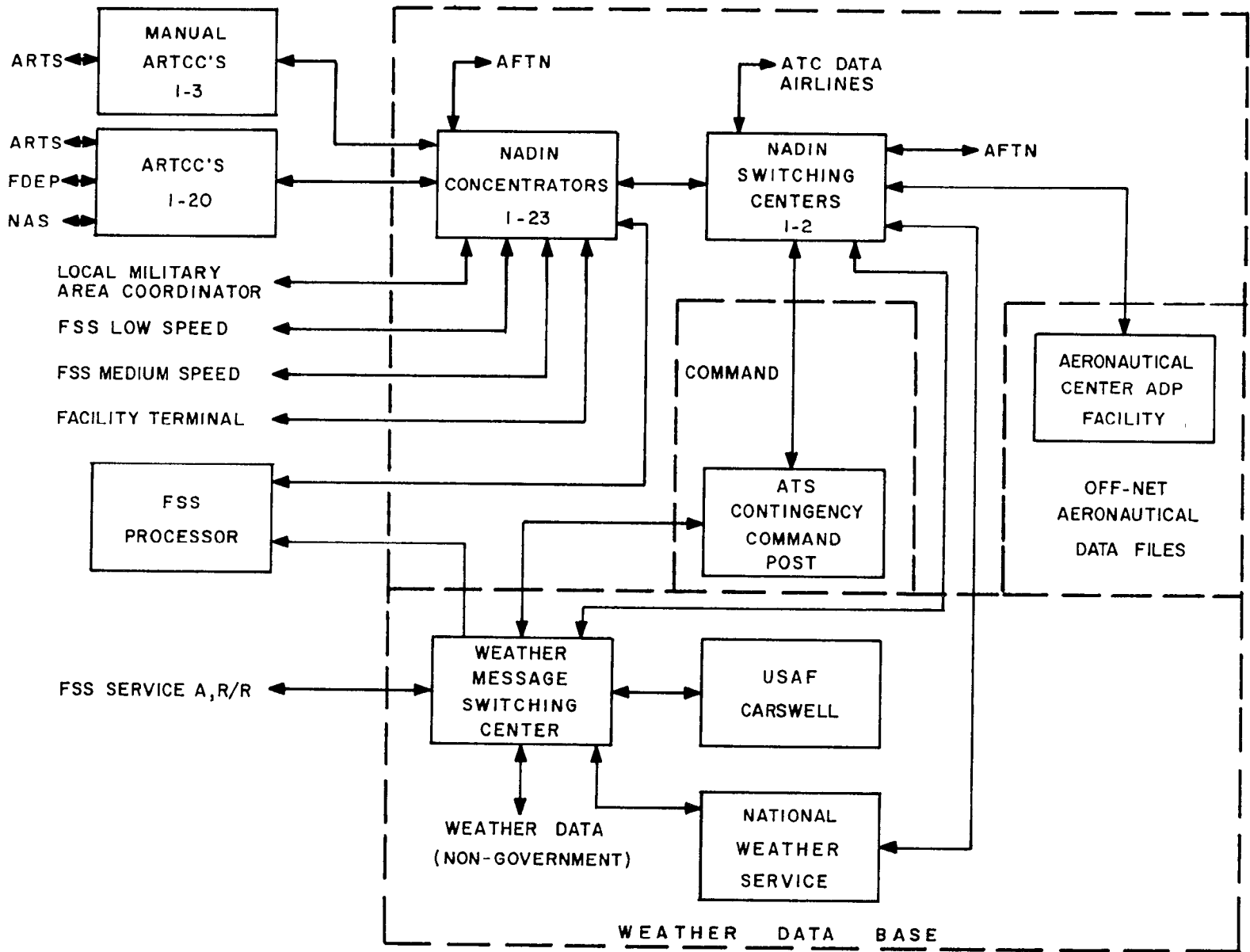

Figure 2-2. NADIN System Configuration (Proposed)

FAA at these sites to provide and maintain an RO teletypewriter/stuntbox on an area "A" circuit for selective calling of the facility by the WMSC computer. The FAA also provides a transmitter-distributor for the transmission of supplemental observations not collected by the AMOS (manned sites only). The method of transmission will vary according to the type of AMOS equipment available, i.e., AMOS 3-70 or AMOS 3-73.

b. **AMOS 3-70.** This system is composed of six sensing devices, which propagate pulsed information to a

processing unit. The processing unit encodes the data and stores it in the proper format for transmission. Upon receipt of a scan call from the computer, the processor's message composer electronically transmits the message to the line. A manual entry device (MED) is provided to allow a preset message to be added to the AMOS message. The MED allows an observer to enter cloud ceiling, visibility, snow or fog, etc. If additional information is to be sent, then the final remarks device (FRD) can be enabled. The FRD activates a local transmitter-distributor (TD) 150 milliseconds after the AMOS message has ended for transmission of a punched tape. (See figure 2-3.)

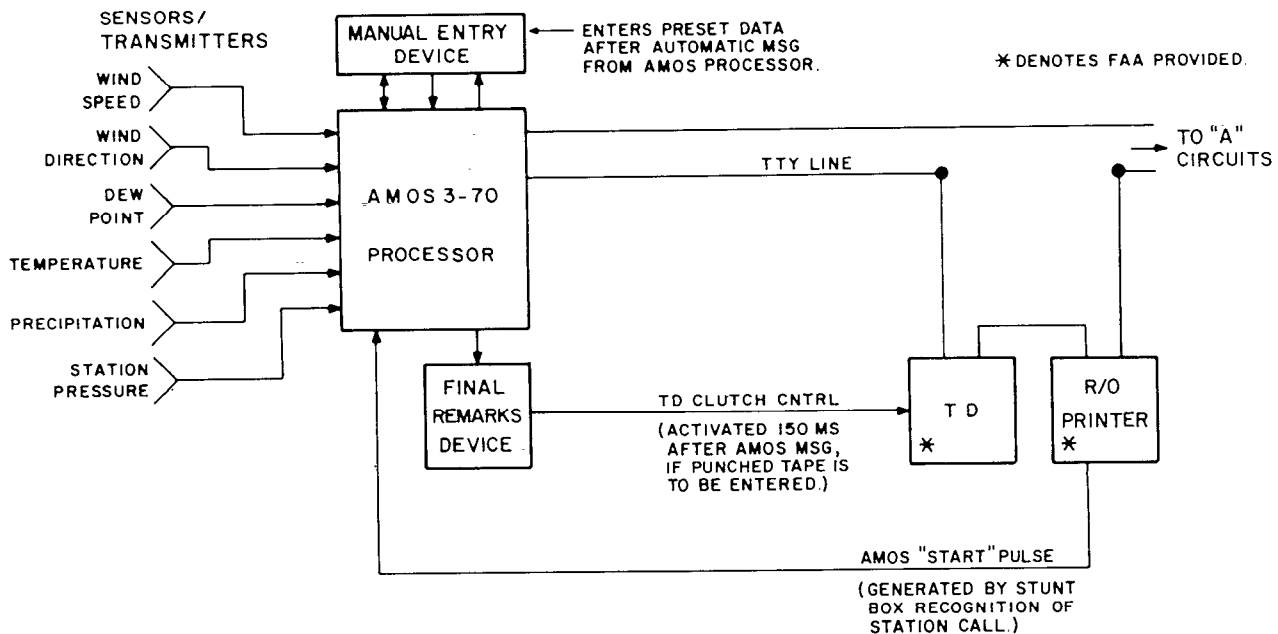

Figure 2-3. AMOS 3-70 System

c. The AMOS 3-73 system employs a local readout device (LRD) in place of the FRD and MED used in the AMOS 3-70 system. The LRD enables the AMOS processor to be switched either to the line for automatic transmission (unmanned operation) or to a local dummy circuit (manned operation). The dummy circuit allows AMOS data to be printed locally for recomposition with additional observations. The recomposed message is then transmitted via punched tape upon reception of station call. (See figure 2-4.)

26. FAA COMSEC.

a. Automatic Digital Network (AUTODIN) is a worldwide Department of Defense (DOD) communi-

cation system providing secure communication capabilities to all government agencies requiring them. AUTODIN is a fully-automatic, computer-controlled, switching system with automatic electronic switching centers (AESC) located at eight different locations across the country. Numerous types of subscribers are serviced by the AESC's; computer tributary terminals, operating at very high speeds, down to low-speed 12-card per minute terminals. FAA utilizes the mode V teletypewriter terminal. The terminal consists of a control unit, an automatic send-receiver set (ASR), a receive-only set (RO), and a TSEC/KW-26C or TSEC/KG-13 crypto system.

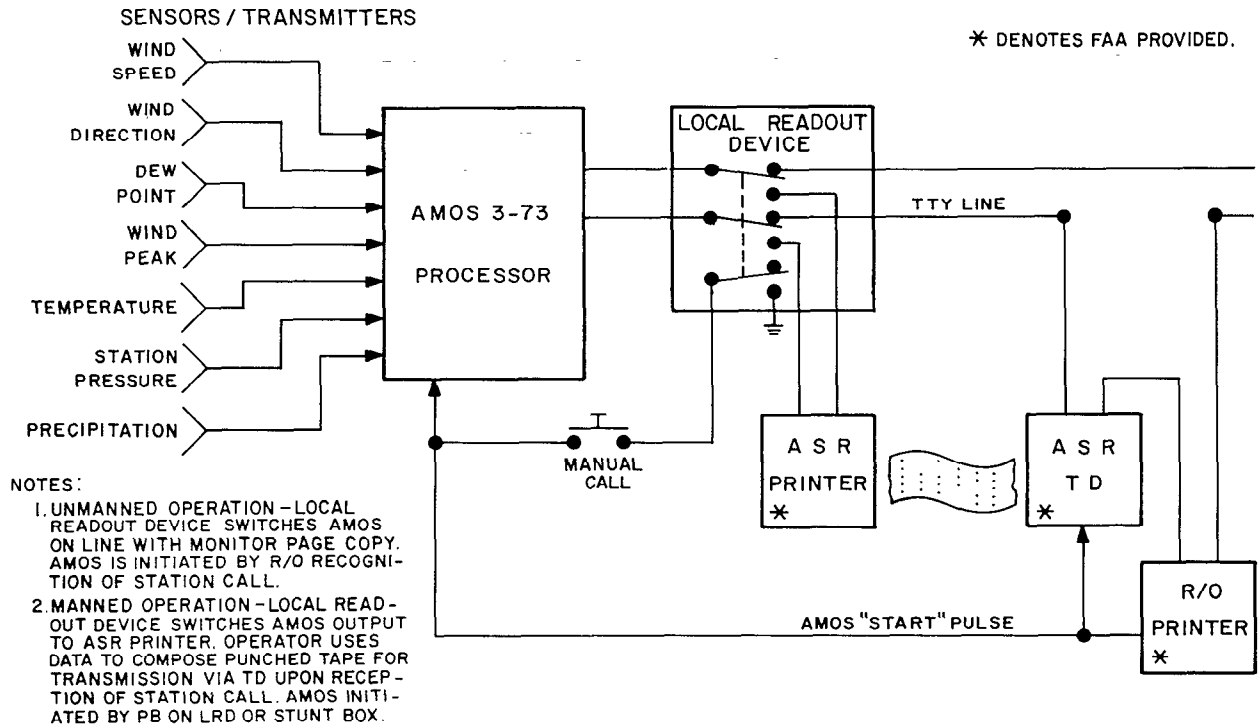

Figure 2-4. AMOS 3-73 System

b. TSEC/KW-26C.

(1) The control unit 12008.1 (low-level) responds to signals from the AESC and controls the operation of the ASR/RO sets, such as stop-start sending or receiving, canceled transmissions, priority interruptions, message acknowledgement, and message rejections.

(2) The mode V terminals are full-duplex tributaries, operating at ML-STD-188B signaling and keying levels. The ASR/RO sets were modified to operate low-level through the use of National Security Agency (NSA) teletypewriter keyers and selector magnet drivers. Refer to figure 2-5 for a typical block diagram of the mode V terminal.

(3) Mode V Test Fixture. Because of the absence of patch facilities and the use of the low-level keyers and selector magnet drivers, it is necessary to use the mode V test fixture for the testing of the keyers and selector magnets with the mode V control unit disconnected. Different positions of the test fixture switch provide the combinations necessary to check out all keyers and drivers.

(a) Test Switch Position 1 - With keyboard selector switch in the K or T position, transmission from TD to ASR page printer (TD) monitor is accomplished.

TD-Keyer → SMD → TD Monitor

(b) Test Switch Position 2 - With keyboard selector switch in the K or T position, TD to RO and perforator (RPF) transmission is accomplished.

TD-Keyer → SMD → RO and RPF

(c) Test Switch Position 3 - With keyboard selector in the K position, transmission from ASR keyboard to the RO and RPF is accomplished.

ASR KYBD-Keyer → SMD-RO and RPF

(d) In order to provide a testing capability of the KSR set, a patch cord is available to complete a circuit from the ASR TD keyer or keyboard keyer to the KSR selector magnet driver.

KYBD → ASR Keyers → SMD-KSR PRINTER
 TD

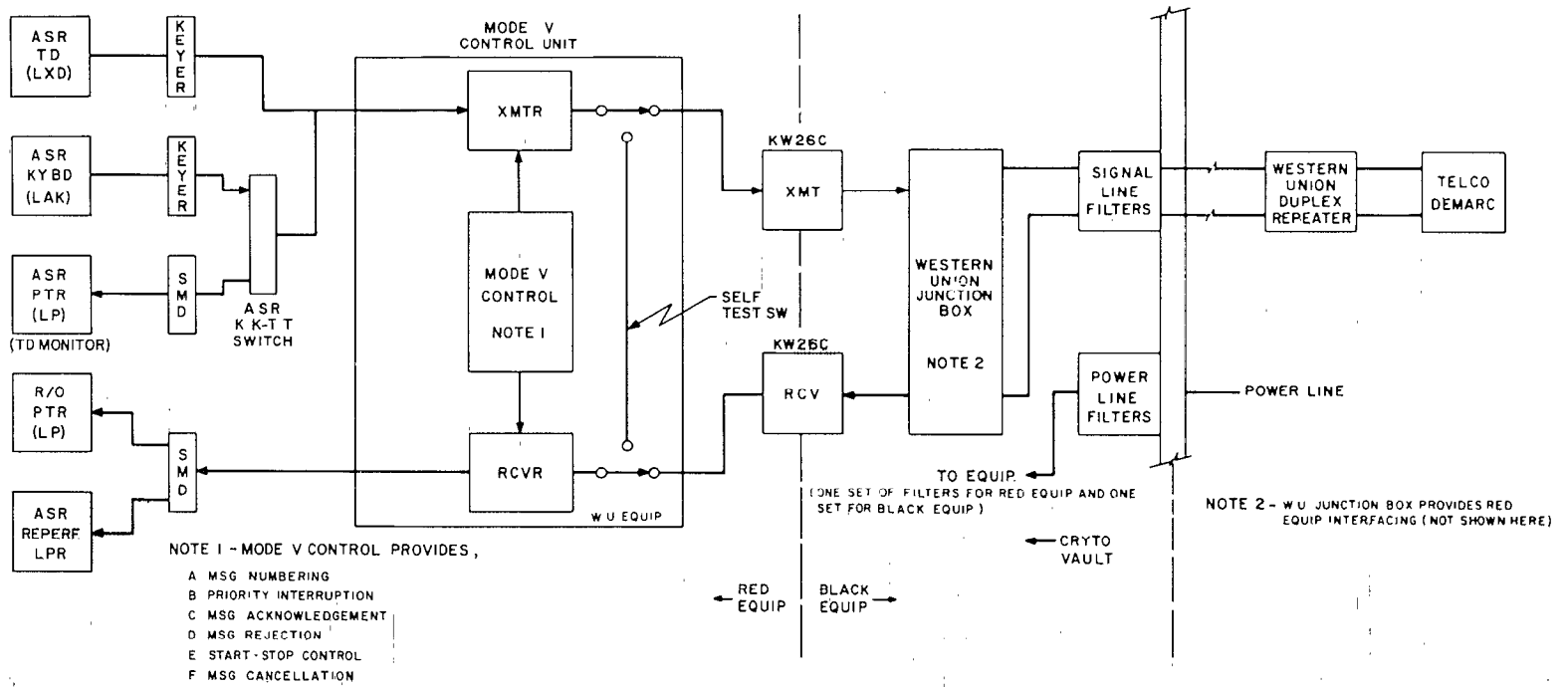
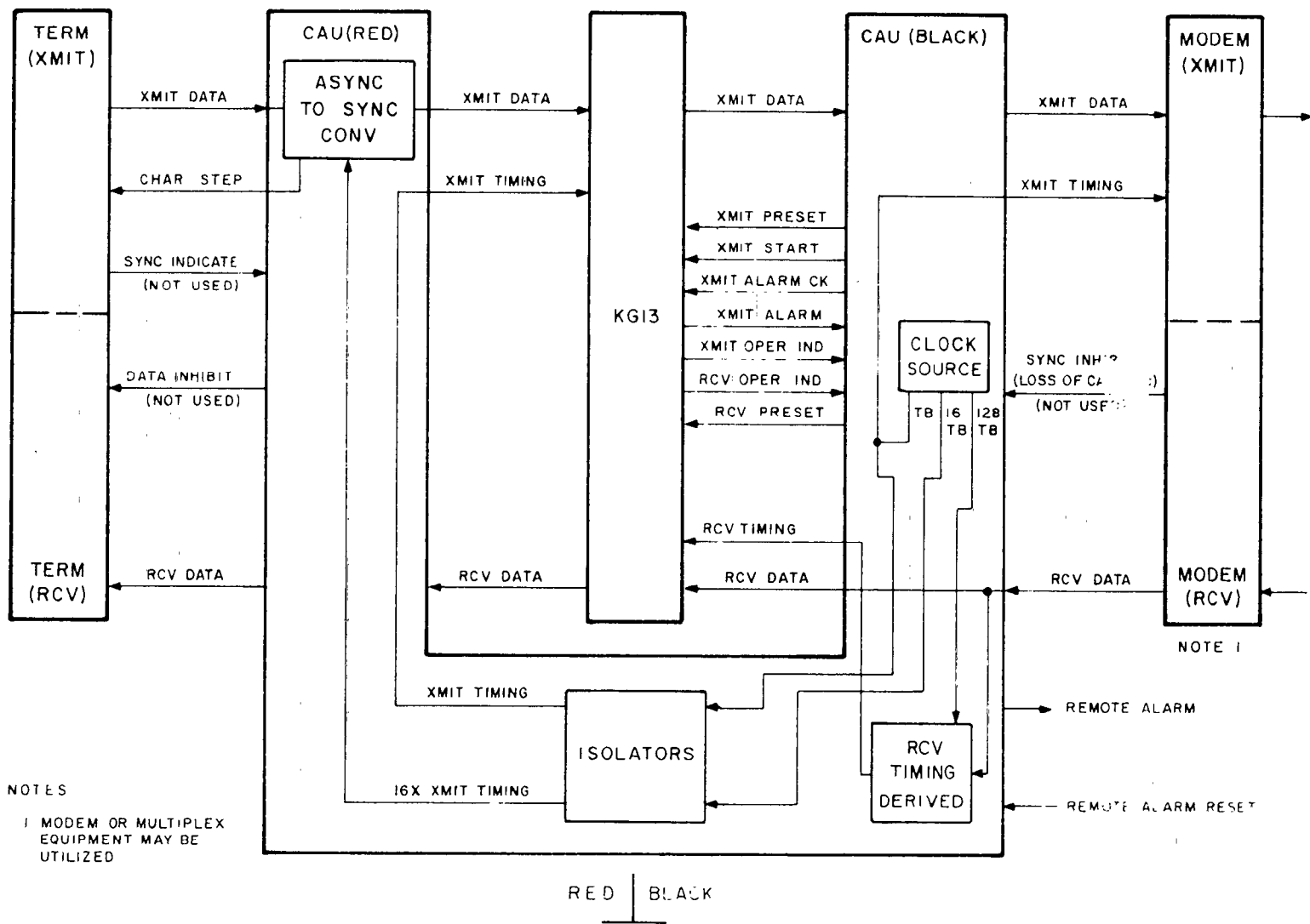

Figure 2-5. Mode V Asynchronous AUTODIN, TSEC/KW-26C



NOTES
1 MODEM OR MULTIPLEX EQUIPMENT MAY BE UTILIZED

Figure 2-6. Mode V Synchronous AUTODIN, TSEC/KG-13

c. **TSEC/KG-13.** The mode V configuration of the TSEC/KG-13 is shown in figure 2-6. The CAU must accommodate KG-13 synchronous signaling, while the TSEC/KW-26C control unit (figure 2-5) uses asynchronous signaling.

(1) **Crypto Auxiliary Unit CAU-21A0 (AN/UYK-22 () V).** The CAU control unit accommodates synchronous and asynchronous signaling. It will convert teletypewriter asynchronous start-stop Baudot code to a synchronous form compatible with key generator TSEC/KG-13. It provides automatic synchronization of the encrypted signal and has an optional manual

synchronization capability for use in troubleshooting. Details of FAA utilization of the CAU are contained in the latest edition of Order 6170.7, Installation and Maintenance of COMSEC Equipment, a classified document available only on a need-to-know basis.

(2) **Mode V Test Fixture.** A test fixture similar in purpose and operation to that described in subparagraph 26b(3) for the TSEC/KW-26C is used with the TSEC/KG-13 configuration. It is the same test fixture modified for the specific application.

27.-29. RESERVED.

Section 2. EQUIPMENT DESCRIPTION

30. GENERAL.

a. The three data-handling terminal models in current FAA use are the M28, M35, and M37 teletypewriters; all are manufactured by the Teletype Corporation of Skokie, Illinois. The 60, 75, and 100wpm M28 replaced the older M14, M15, and M19 equipment approximately 20 years ago. The M28 (as did its predecessors) uses the Baudot five-level start-stop telegraph code. A similar but more modern equipment, the M35, uses the eight-level ASCII code. The M28 is the general-purpose communication and weather-message teletypewriter. The M35 will be used in the IBM 9020 central computer complex and as an alarm readout printer in the central control and monitoring system (CCMS) at ARTCC's and at AWANS Facilities. The M35 is also a 60, 75, and 100 wpm unit. The M37 handles up to 150wpm speeds, has many dissimilarities to the M28 and M35 units; and its principle agency application is in the automated radar terminal system (ARTS). Table 2-1 compares general features of the three equipments. A Model 40/Data Terminal Equipment (M40/DTE) is scheduled as a replacement for the communications and weather message application of the M28 and will be covered by a separate maintenance technical handbook.

b. Fundamental telegraph/teletypewriter circuit theory is located in the latest edition of Order 6170.4, Teletypewriter Installation. The order also contains detailed M28 schematic and wiring diagrams, including troubleshooting schematics. Detailed theory, description, schematic and wiring diagrams, and overhaul disassembly and reassembly of the M35 equipment are located in Preliminary Instruction Book, Automatic

Send-Receive Teletypewriter Set (ASR-35) Type FA-7938, Volumes I and II. Similar detailed information is provided for the M37 ASR equipment in Teletype Corporation Bulletins 318D, Volumes 1, 2, and 3. For a listing by national stock number (NSN) of agency-applicable Teletype Corporation equipment publications, refer to Appendix 4.

c. Letter designations for the various Teletype Corporation Bulletins or Sections are:

A.....Adjustment	O.....Operation
D.....Description	P.....Parts
D & R.....Disassembly and Reassembly	T.....Theory
L.....Lubrication	

31. DATA-HANDLING TERMINAL SETS.

Data-handling terminals are comprised of one or more of the types of equipment described in the following subparagraphs. More detailed descriptions may be found in the associated manufacturers' bulletins. The bulletins are composed of sections pertaining to individual apparatus or subunits. If required, bulletins should be ordered by the section using the national stock number (NSN) listed in Appendix 4.

a. Table 2-2 lists the apparatus codes for M28, M35, and M37 equipment.

Table 2-1. COMPARISON OF M28, M35, AND M37 TELETYPEWRITERS

<i>M28 Series</i>	<i>M35 Series</i>	<i>M37 Series</i>
Code: five level Baudot	Code: eight-level ASCII (pre-1967)	Code: eight-level ASCII (1967)
Speed: 60, 75, or 100wpm	Speed: 100wpm	Speed: 150wpm
Stunt Box: Electromechanical	Stunt Box: Electromechanical	Stunt Box: Electromechanical
Keyboard: 3 rows, requires shift to upper case for figures and certain other symbols	Keyboard: 4 rows, no shift required for figures; capital letters only	Keyboard: 4 rows, upper and lower case letters; no shift required for figures
Parity: None	Parity: Even; generation from the keyboard	Parity: Even; generation from the keyboard and parity recognition
Printing: Type box	Printing: Type box	Printing: Type box using aggregate motion principle
Major Configurations: ASR, KSR, RO	Major Configurations: ASR, KSR, RO	Printing: Type box using aggregate gate motion principle Major Configurations: ASR, KSR, RO

b. RO Printer. The RO is a message-receiving unit, page printer (LP) providing a printed page of copy. The unit features a selective calling capability, enabled by the function box, which allows calling from a remote facility. The unit is housed in a LAC cabinet, provided with signals and ac power through an electrical service unit (LESU), and mounts on an LB keyboard base (with no keyboard) within the cabinet.

c. Keyboard Send-Receive (KSR) Set. With the KSR half-duplex, both sending and receiving is possible. The KSR has the same components as the RO except for a keyboard base (LK). The LK allows for keyboard transmission.

d. ASR Set. An ASR is used in both half-duplex and full-duplex operation and as a tape preparation facility. Through the use of K, K-T, T (keyboard, keyboard-tape, tape) switch it is possible to: (1) K position, transmit directly from the keyboard (LAK), with monitor page copy provided by typing unit (LP); (2) K-T position, transmit from keyboard, with monitor page

copy and perforated tape from a perforator (LPE) or reperforator (LPR); (3) T position, preparation of tape from the keyboard with printer free for monitoring tape transmission or receiving messages from the line. The TD is dedicated to tape transmission regardless of switch position. There are various combinations of subunits available in the ASR, as shown by figure 2-7.

e. Apparatus. See figure 2-8 for M28 apparatus designations.

f. Reperforator Transmitter-Distributor (RT) Set. The RT set provides a low-speed store and forward relay capability. It is composed of one LPR for receiving messages. The output of the LPR provides a punched tape to the tape handling stand (LTHS), which stores the tape until it can be transmitted via the TD (LAXD). The relay function is completely automatic. The LPR and LAXD are mounted on an LRXB RT base enclosed in an LBAC cabinet.

Table 2-2. M28, M35, AND M37 APPARATUS CODES

<i>M28 and M35</i>	<i>Equipment Unit</i>	<i>M37</i>
ASR.....	Automatic Send-Receive Set.....	ASR
KSR.....	Keyboard Send-Receive Set.....	KSR
RO.....	Receive-Only Set.....	RO
RT.....	Reperforator-Transmitter Set.....	
LP.....	Typing Unit.....	YP
LESU.....	Electrical Service Unit.....	YESU
LAC, LBAX, LPC.....	Apparatus Cabinet.....	YAC
LAK.....	Keyboard Unit.....	YK
LPE, LTPE.....	Typing and Nontyping Perforators.....	
LPR.....	Typing Reperforator.....	YPR
LRPE.....	Nontyping Reperforator.....	YRPE
LXD, LAXD, LCXD.....	Transmitter-Distributor.....	YTD
LCXB.....	Transmitter-Distributor Base.....	
LBXD.....	Transmitter-Distributor, Multicontact	
LMU.....	Motor Unit.....	YMU
LAAC.....	ASR Cabinet.....	
LRXB.....	Reperforator-Transmitter.....	
LTHS.....	Tape Handling Stand.....	

g. Multiple Subunit Sets. The LPR, LP, and TD may also be used in a single or multiple unit configuration. All of the multiple installations will be housed in an LBAC-type cabinet. The individual mountings of the TD and LPR are the AC-273 cabinet and the LT-200 table, respectively.

h. Transmitter Control Device (Relay Group). The relay group utilizes the operation of the line relay associated with a printer set to provide open and busy line

alarm signals, which are represented by corresponding lights mounted on the printer set. The alarm signals automatically prevent the transmission of a message into a line when the line is busy or open, and indicate when the line is idle for transmissions to line. It also provides a "start" signal, which enables the transmitter-distributor whenever a "start request" is received by the function box or initiated by the manual push-button. When a start request is initiated during a busy line condition, circuitry exists to provide retention of the request until the line becomes idle.

The following chart lists the numbers of bulletins covering components of the ASR set, such as, parts ordering (P), adjustments and lubrication (A&L), description and theory of operation (D&T).

PAGE PRINTER	LP	Typing Unit	1149B (P) 216B (D&T) 217B (A&L)
KEYBOARD	LAK	Perforator Transmitter Base	1169B (P)
PERFORATOR OR REPERFORATOR	LPE	Nontyping Perforator	1169B (P)
	LTPE	Typing Reperforator	249B (D&T) 250B (A&L)
	LRPE	Nontyping Reperforator	1172B (P) 256B (A&L)
	LPR	Typing Reperforator	1167B (P) 246B (D&T) 247B (A&L)
BASE	LCXB	Transmitter Distributor Base	1169B (P)
TRANSMITTER DISTRIBUTOR	LXD	Fixed Head, Single Contact Trans. Dist.	1161B (P) 258B (D&T) 235B (A&L)
	LAXD	Pivoted Head, Multi-contact Trans. Dist.	1170B (P) 251B (D) 252B (A&L)
	LBXD	Fixed Head, Multi-contact Trans. Dist.	1165B (P) 243B (A&L)
	LCXD	Fixed Head and Pivoted Head, Multi-contact Trans. Dist.	1171B (P) 252B (D&T) 254B (A&L)
MOTOR	LMU	Motor Unit	1169B (P)
ELECTRICAL SERVICE UNIT	LESU	Electrical Service Unit	249B (D&T) 250B (A&L)
CABINET KEYTOP WITH LEVER AND TYPEALLETS	LAAC	Automatic Send - Receive Cabinet Murray, Gothic, Long Gothic, and Large Gothic Styles	1164B (P)
GEAR SETS (For gears used with the LPR or LRPE see appropriate bulletin.)	160675	Gear Set for 60 W.P.M. Speed Includes: 158084 Gear Set for Keyboard (LAK) and 158029 Gear Set for Base (LCXB)	1169B (P) 250B (A&L)
	160676	Gear Set for 75 W.P.M. Speed Includes: 158082 Gear Set for Keyboard (LAK) and 158028 Gear Set for Base (LCXB)	
	160677	Gear Set for 100 W.P.M. Speed Includes: 158080 Gear Set for Keyboard (LAK) and 158027 Gear Set for Base (LCXB)	

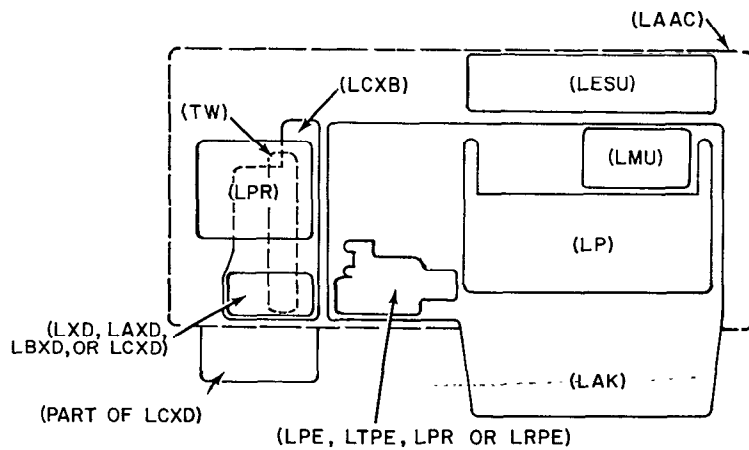

Figure 2-7. M28 ASR Subunits

<u>ASSEMBLY</u>	<u>DESIGNATION</u>	<u>MEANING</u>
<p>Typing Unit</p> 	 <p>L P 12 RE / AR</p>	<p>Model 28 Printer Model Number Typebox Arrangement Stunt Box Arrangement (Model Number includes accessories)</p>
<p>Transmitting Keyboard</p> 	 <p>L K 16 ARE</p>	<p>Model 28 Keyboard Model Number Keytop Arrangement (Model Number includes accessories)</p>
<p>OR Receive Only Base</p> 	 <p>L B 4 / 146</p>	<p>Model 28 Base Model Number Accessory Group (Model Number will later incorporate accessories)</p>
<p>Electrical Service Unit</p> 	 <p>L ESU 7 / 246</p>	<p>Model 28 Electrical Service Unit Model Number Accessory Group</p>
<p>Motor</p> 	 <p>L MU 3</p>	<p>Model 28 Motor Unit Model Number</p>
<p>Consoles</p> 	 <p>L AC 204 AB 222 (PC)</p>	<p>Model 28 Apparatus Cabinet (Floor--Table) (Printer Cover) (Rack Mount) Model Number Color Accessory Group</p>

Figure 2-8. M28 Teletypewriter Apparatus Designations

i. **Line Switching Unit (LSU) CA-1696.** The LSU can manually switch a given unit of receiving or transmitting equipment with its 10 control leads to any one of 10 teletypewriter signal lines that may be connected to that LSU.

j. **Telegraph Loop Terminal Jack Panel (TLT) CA-1713.** The TLT provides a 3-jack group for each of 12 circuits. One jack is the line, one is the equipment, and the third is a looping jack, which allows a milliammeter to be patched in series to measure the loop or circuit signaling current.

k. **K-6 Push-Key Cabinet.** The K-6 cabinet is a six-by-six patch facility, providing each of six equipment lines access to one of six signal lines. Provisions are available to test a signal line by providing a short, ground trip, and ground sleeve or ring.

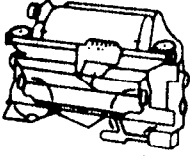
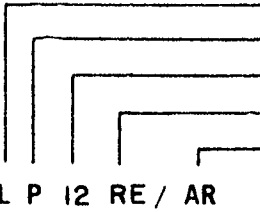
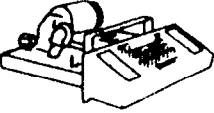
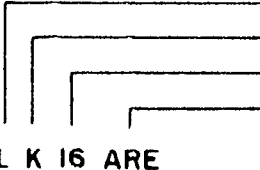
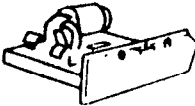
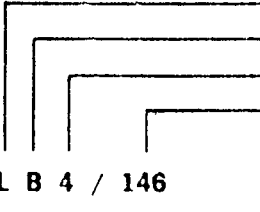
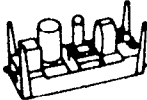
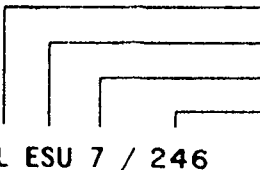
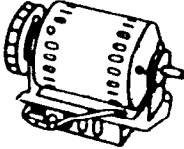
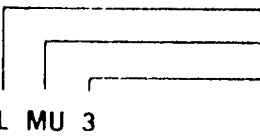
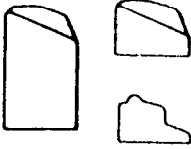
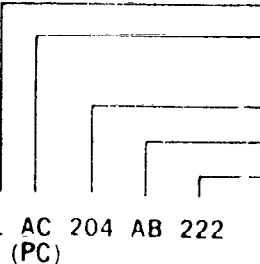
l. **TELECOM Switching Unit Model TSU-10.** The Model TSU-10 provides line circuit and control switching for data-handling terminal equipment, similar to the CA-1696LSU. It is a more diversified equipment for it provides for line testing and loop current adjustment and may contain optional repeaters for circuit isolation and different input/output line current levels of 20 and 60mA. Basically, the TSU-10 has the switching capability to handle up to 10 teletypewriters to be operated on any one of six dc telegraph circuits, of which five are signaling circuits and one a dc test loop. Test panel TP-3 provides pushkey access to each of the signal lines and metering for line current measurement and adjustment. Power supply PS-3 supplies control relay voltage. For details of operation, theory, and installation, with schematics and wiring diagrams, refer to the Service Manual, TELECOM Switching Unit, Model TSU-10, 810-00062, DIGITECH, Data Industries, Inc., 66 Grove Street, Ridgefield, Connecticut, 06877, September, 1975.

m. **Automatic Program Unit Low Speed (APULS).** Two models of this equipment exist: the early type CA-5032, and a later type FA-5032A. These similar units are used as automatic, tapeless teletypewriter circuit control, and scanning devices. They are employed on service B and weather message circuits described in paragraphs 21 and 22. Full details of this type of equipment are included in the two instruction books: Instruction Book, Automatic Program Unit Low Speed (APULS), Type CA-5032, Stelma, Incorporated, * Stamford, Connecticut; and Instruction Book, Automatic Program Unit Low Speed (APULS), Type FA-5032A, Stelma, Incorporated, Stamford, Connecticut. *

32. SUMMARY OF M28 TELETYPEWRITER TECHNICAL CHARACTERISTICS.

a. **Signal Requirement.** Sequential, five intelligence levels, one start pulse, one stop pulse 1.42 times the length of the other pulses, 20 or 60mA neutral line signal. Capable of half-duplex or full-duplex operation.

b. **Operating Speed, 100 wpm (see table 2-6).**

- (1) Characters per minute.....600
- (2) Unit code.....7.42
- (3) Modulation rate.....74.2 bauds
 - (a) One character100ms
 - (b) Unit pulse.....13.47ms
 - (c) Stop pulse.....19.13ms

c. **Power Requirements from External Source.....**
115V ac, 60 ± 0.75Hz, single phase

d. **Characteristics Peculiar to Page Printers.**

(1) **Type Pallet Arrangements.**

- (a) Communication.....
Upper case; figures shift used for numerals and punctuation
- (b) Weather.....
Upper case and figures shift

(2) **Type Styles and Spacing.**

- (a) Style.....Gothic
- (b) Character height.....0.103 inch (2.6mm)
- (c) Communication, horizontal characters per inch, single space.....12
- (d) Weather, horizontal characters per inch, single space.....10
- (e) Vertical lines per inch.....
6 (single feed); 3 (double feed)

(3) **Platen.**

- (a) Type.....
Friction feed, 8½ inch (21.6cm)

- (3) Platen.
 - (a) Type..... Friction feed, 8½ inch (21.6cm)
 - (b) Maximum characters per line..... 80 (communication); 72 (weather)
- (4) Typing Unit Ribbon.
 - (a) Style.....black record
 - (b) Length.....33 feet (10.1m)
 - (c) Width.....1/2 inch (12.7mm)

- (3) ASR..... 39.0 36.0 23.0
(99.1cm) (91.4cm) (58.4cm)
- (4) LPR (table 9-1/4 13.0 14-1/8
model) ... (23.5cm) (33.0cm) (35.9cm)
- (5) RT..... 60.0 28.0 27.0
(154.4cm) (71.1cm) (68.6cm)
- (6) TD (LBXD 6-1/2 6-1/2 16.0
table
model) ... (16.5cm) (16.5cm) (40.6cm)
- (7) TD (M14)..... 10.0 10.0 16-1/2
(25.4cm) (25.4cm) (41.9cm)

e. Characteristics Peculiar to Tape Handling Equipment.

- (1) Tape..... Paper, standard communication, five-level
- (2) Width..... 11/16 inch (17.5mm)
- (3) Code perforations..... Chadless or chaddled
- (4) Characters or feedholes per inch.....10
- (5) Printed characters.
 - (a) Height..... 0.120 inch (3.05mm)
 - (b) Width..... 0.075 inch (1.9mm)
 - (c) Location of printing..... Along upper edge of tape

f. Dimensions.

(1) RO.	Height (in.)	Width (in.)	Depth (in.)
(a) Floor model.....	39.0 (99.1cm)	20-1/2 (52.1cm)	21.0 (53.3cm)
(b) Multi-ple.....	72.0 (182.8cm)	21-1/2 (54.6cm)	28.0 (71.1cm)
(2) KSR.....	39.0 (99.1cm)	20-1/2 (52.1cm)	24.0 (60.9cm)

33. SUMMARY OF M35 TELETYPEWRITER TECHNICAL CHARACTERISTICS.

a. Signal Requirement. Sequential, seven intelligence levels, one parity level, one start and two stop pulses, 500mA selector magnet current, and either 20mA or 60mA neutral line current into the selector magnet driver. Half-duplex or full-duplex circuit operation may be accommodated.

b. Operating Speed, 100 wpm. (See Table 2-6.)

- (1) Characters per minute.....600
- (2) Unit code.....11
- (3) Modulation rate.....110 bauds
 - (a) One Character.....100ms
 - (b) Unit pulse.....9.09ms
 - (c) Stop pulse.....18.18ms

c. Power Requirements from External Source..... 115V ac, 60 ± 0.5Hz single phase.

d. Characteristics Peculiar to Page Printers.

(1) **Type Pallet Arrangements.** Communications, upper case only.

(2) **Type Style and Spacing.**

- (a) Style.....Gothic
- (b) Spacing..... 0.103 inch (2.6mm)

- (c) Communications, Horizontal Characters per inch, single space.....12
- (d) Vertical lines per inch,
 - single feed.....6
 - double feed.....3

(3) **Platen.**

- (a) Type..... Friction or sprocket, 8-1/2 inch (21.6cm)
- (b) Maximum characters per line.....80

(4) **Typing Unit Ribbon.**

- (a) Style..... black record (red/black optional)
- (b) Length.....33 feet (10.1m)
- (c) Width..... 1/2-inch (12.7mm)

e. Characteristics Peculiar to Tape Handling Units.

- (1) Tape..... Paper, standard communication, 8-level
- (2) Width.....1.0 inch (2.54cm)
- (3) Perforations.....chadded only
- (4) Characters or feed holes per inch.....10
- (5) Printed characters.....Top edge of tape

f. Dimensions (ASR-35).....See M28 ASR

34. SUMMARY OF M37 TELETYPEWRITER TECHNICAL CHARACTERISTICS.

a. Signal Requirement. Same as M35.

b. Operating Speed, 150wpm. (See Table 2-6.)

- (1) Characters per minute.....900
- (2) Unit code.....11
- (3) Modulation rate.....165 bauds

- (a) One character.....66.66
- (b) Unit pulse.....6.06ms
- (c) Stop pulse.....12.12ms

c. Power Requirements from External Source.....
117V ac, 60 ± 0.75Hz, single phase.

d. Characteristics Peculiar to Page Printers.

- (1) Type Pallet Arrangement..... Communications, upper case alpha; prints all 94 alpha, numeric, and graphic characters of ASCII code.
- (2) Type Style.....Gothic
- (3) Characters printed per inch..... 10
- (4) Form feed..... 3 lines/character interval
- (5) Horizontal and vertical tabulation..... Fixed stops to customer specification.
- (6) Characters printed per line..... 72 on 8-1/2 inch (21.6cm) platen.
- (7) Typing unit ribbon.....See M35 data.

e. Characteristics Peculiar to Tape-Handling Units.
See M35 data.

f. Dimensions.

	<i>Height (in.)</i>	<i>Width (in.)</i>	<i>Depth (in.)</i>
(1) RT module....	26-1/2 (67.3cm)	22 (55.9cm)	23-25/32 (60.4cm)
(2) Two-compartment table.....	36 (91.4cm)	32-1/2 (82.6cm)	31-3/4 (80.6cm)
(3) Single-compartment table.....	36 (91.4cm)	22-1/2 (57.2cm)	31-3/4 (80.6cm)

35.-39. RESERVED.

Section 3. DATA CODING, SELECTIVE SIGNALING, AND SIGNAL DISTORTION

40. GENERAL.

a. This section discusses coding, selective signaling and effects and measurement of signal distortion.

Coding is the conversion of machine language into data bits for transmission of intelligence and control characters over a wire line or other transmission med-

ium. Selective signaling uses designated data receivers that are polled and conditioned for receiving and printing messages. Signal distortion is the degradation of a normal or ideal transmitted signal by either the transmitter mechanism or the medium of transmission and the resulting effect on the receiving mechanism and data printout.

b. Although there are many coding schemes for the transmission of binary signal data, including a number used exclusively for the detection and correction of

transmission errors, this section describes four kinds. These are the Baudot five-level teletypewriter code, the American Standard Code for Information Interchange (ASCII), the Extended Binary Coded Decimal for Information Code (EBCDIC), and the Moore Automatic Repeat-Query (ARQ) error correcting code. A form of coding called "message coding" is discussed in the subsection on selective signaling. This is a code not used for transmission but one using certain nonprinting machine functions to effect message routing and selective conditioning.

Subsection I. BAUDOT CODING

41. START-STOP TELEGRAPHY.

a. To obtain maximum utilization, flexibility, accuracy, and reliability of the data-handling terminal equipment, maintenance personnel must have a general understanding of the basic principles of start-stop (asynchronous) telegraphy. It is assumed that the reader is familiar with the conventional telegraph systems, so this review of the fundamentals of start-stop telegraphy will call special attention to certain specific

features. More details of the fundamentals of start-stop telegraphy may be found in various equipment instruction books and other publications. The code of electrical impulses in start-stop telegraphy systems consists of a start signal, normally a space (no current) to notify the receiving equipment of the start of the character; a series of bits that convey the intelligence to the receiving station; and a stop signal, normally a mark (current) to notify the receiving equipment of the end of the character.

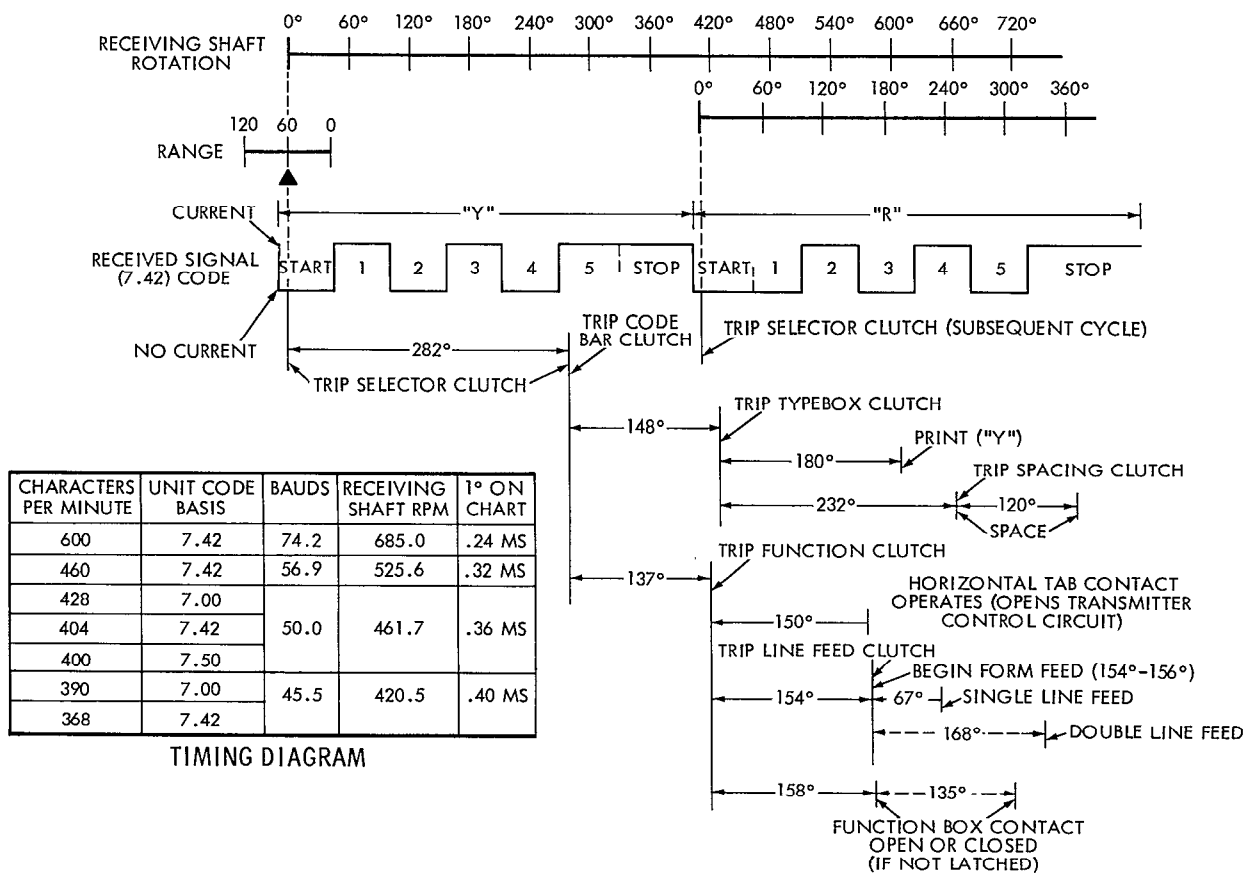

Figure 2-9. Functioning of Baudot Five-Level Code

b. The selecting mechanism of the receiver translates the signaling code combinations into corresponding mechanical arrangements which ultimately result in the performance of the desired function. Although start-stop codes exist that employ different numbers of intelligence or information bits and different types of stop signals, the 100wpm FAA system uses one of the most common codes (illustrated in figure 2-9). It contains a start signal (start-space), five intelligence bits (marks or spaces or combinations of marks and spaces), and a stop signal (stop-mark) having a time duration of 1.4 times the duration of one information bit. This particular code is called 7.42-unit Baudot code, derived from the total of the start-space (1 bit), the information bits (5 bits), and the stop-mark (1.42 bits). The start pulse, which is always a space added to the beginning, and the stop pulse, which is always a mark added at the end of each combination of intelligence bits, are used to insure synchronization between the transmitting and receiving equipments.

c. Each operation is initiated by a mark-to-space (M-S) transition at the beginning of the start bit of the received character. The speed of the receiving equipment should be such that it arrives at the stop position before the end of the stop mark. Since it is restarted by the succeeding M-S transition, any speed difference between the transmitting and receiving machine is prevented from accumulating for more than the duration of a signal character. When a message begins, the first bit of signal (start pulse) is identified to the receiver by the first M-S transition. The receiver starts anew at each transition and samples the intelligence bits in times relative to the transition.

d. The start transition acts as the reference time point to which all other instants of time during the selective cycle are referred. In start-stop systems, it is not the duration of signal intervals that is of primary importance, it is the time of signal transition relative to the start transition. Departures from perfect timing are known as start-stop displacements and are defined as signal distortion.

e. When the receive station equipment receives the start-space, it begins its selection sequence. A properly designed and adjusted start-stop teletypewriter actually requires only a small portion of the time of each signal element to make a selection; i.e., to determine whether the signal bit is a mark or a space. The remainder of the signal bit gives an operating margin and serves as a reserve to take care of imperfections in the receiver or distortions which the signals may suffer between the transmitting and receiving stations during transmission. The greater the signal distortion, the smaller the margin will be to overcome the effect of such factors as wear of parts, variation of adjustments, or differences in speed between the transmitting and receiving equipment.

f. The paper tape versus character or function layout of the Baudot code is illustrated in figure 2-10. Perforations (mark or "1" bit) are indicated by a solid dot; spaces (no perforations) are indicated by a circle.

42.-44. RESERVED.

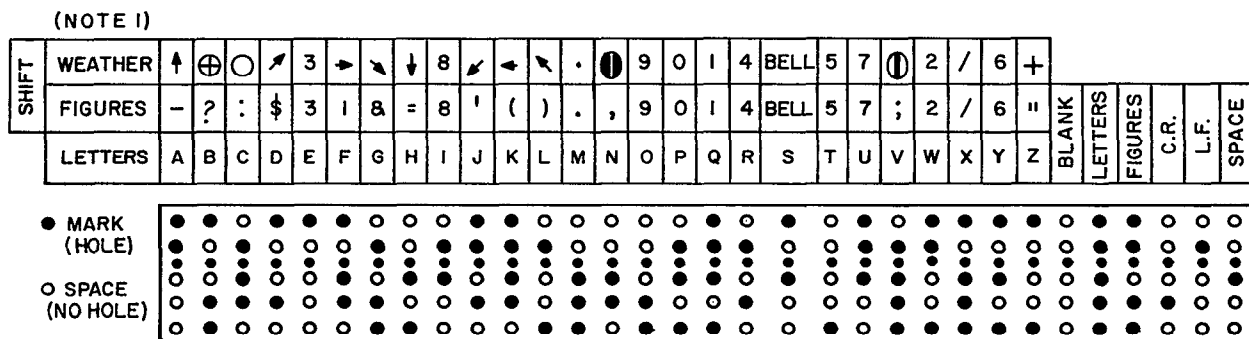

NOTES:
1. FIGURES SHIFT ON WEATHER GRAPHICS KEYBOARD SHOWN ON TOP ROW (TO BE REVISED BY FUTURE MODIFICATION). FIGURES ROW IS COMMUNICATIONS KEYBOARD.

Figure 2-10. Paper Tape Arrangement of Baudot Five-Level Code

Subsection 2. ASCII, EBCDIC, AND ARQ CODING

45. GENERAL.

A demand exists today for codes with greater capacity and logical format, such as the ASCII and EBCDIC codes, than for the older five-level Baudot teletype-writer code. Federal regulations now require that procurement specifications for data handling equipment provide for ASCII capability at least as an option. Serial versus parallel transmission is also a factor, as it affects transmission speed. The five-level Baudot code is usually transmitted in bit-serial form. The ASCII and EBCDIC codes can be processed internally in bit-parallel fashion but are usually transmitted serially.

46. THE ASCII CODE.

Figure 2-11 illustrates the 11-unit code called ASCII. The 11 signal bits include a start bit, 8 intelli-

gence bits (including a parity bit), and 2 stop bits, all of equal length as shown in the pulse diagram at the top of the figure. This code is also used with punched paper tape as is the Baudot code. The punching arrangement in relation to functions and characters is illustrated in figure 2-12. Note that level 8 is designated with an X. This bit is always marking unless the system is modified for use with an even parity arrangement. The functions illustrated precede the standards adopted in 1967, when unassigned functions were adopted. Table 2-3 lists the standard 1967 functions beginning with NULL, and provides their definitions. The order of appearance from NULL in the table to DEL, corresponds with the order appearing in figure 2-12 with NULL and ending with RUBOUT.

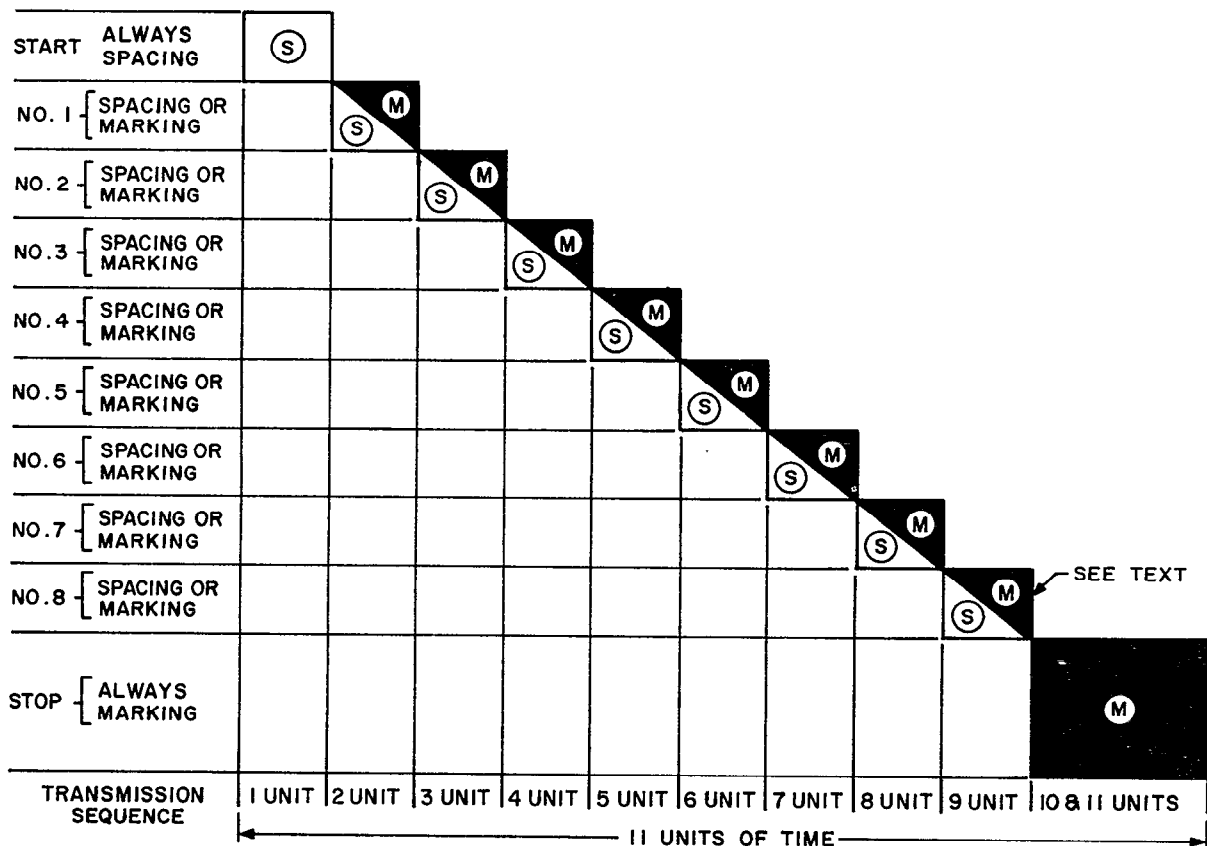
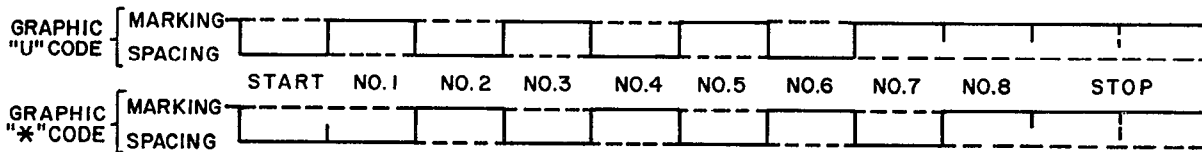

Figure 2-11. ASCII 11-Unit Code Format

FUNCTION REPRESENTATIONS				CHARACTER REPRESENTATIONS				CODE LEVEL
8	7	6	5	4	3	2	1	
X ● ●		SEE TEXT	X ○ ○	● ○ ○	SP	@	X ● ○ ○ ○	○ ○ ○ ○
X ● ●		NULL	X ○ ○	● ○ ○	A	A	X ● ○ ○ ○	○ ○ ○ ●
X ● ●		SOM	X ○ ○	● ○ ○	B	B	X ● ○ ○ ○	○ ○ ○ ○
X ● ●		EOA	X ○ ○	● ○ ○	"	"	X ● ○ ○ ○	○ ○ ○ ○
X ● ●		EOM	X ○ ○	● ○ ○	#	#	X ● ○ ○ ○	○ ○ ○ ○
X ● ●		EOT	X ○ ○	● ○ ○	S	S	X ● ○ ○ ○	○ ○ ○ ○
X ● ●		WRU	X ○ ○	● ○ ○	%	%	X ● ○ ○ ○	○ ○ ○ ○
X ● ●		RU	X ○ ○	● ○ ○	&	&	X ● ○ ○ ○	○ ○ ○ ○
X ● ●		BELL	X ○ ○	● ○ ○	.	.	X ● ○ ○ ○	○ ○ ○ ○
X ● ●		FE ₀	X ○ ○	● ○ ○	((X ● ○ ○ ○	○ ○ ○ ○
X ● ●		H.TAB	X ○ ○	● ○ ○))	X ● ○ ○ ○	○ ○ ○ ○
X ● ●		LINE FEED	X ○ ○	● ○ ○	*	*	X ● ○ ○ ○	○ ○ ○ ○
X ● ●		V. TAB	X ○ ○	● ○ ○	+	+	X ● ○ ○ ○	○ ○ ○ ○
X ● ●		FORM	X ○ ○	● ○ ○	,	,	X ● ○ ○ ○	○ ○ ○ ○
X ● ●		RETURN	X ○ ○	● ○ ○	-	-	X ● ○ ○ ○	○ ○ ○ ○
X ● ●		SO	X ○ ○	● ○ ○	.	.	X ● ○ ○ ○	○ ○ ○ ○
X ● ●		SI	X ○ ○	● ○ ○	/	/	X ● ○ ○ ○	○ ○ ○ ○
X ● ●		DC ₀	X ○ ○	● ○ ○	0	0	X ● ○ ○ ○	○ ○ ○ ○
X ● ●		X ON	X ○ ○	● ○ ○	1	1	X ● ○ ○ ○	○ ○ ○ ○
X ● ●		TAPE ^{AUX} _{ON}	X ○ ○	● ○ ○	2	2	X ● ○ ○ ○	○ ○ ○ ○
X ● ●		X OFF	X ○ ○	● ○ ○	3	3	X ● ○ ○ ○	○ ○ ○ ○
X ● ●		TAPE ^{AUX} _{OFF}	X ○ ○	● ○ ○	4	4	X ● ○ ○ ○	○ ○ ○ ○
X ● ●		ERROR	X ○ ○	● ○ ○	5	5	X ● ○ ○ ○	○ ○ ○ ○
X ● ●		SYNC	X ○ ○	● ○ ○	6	6	X ● ○ ○ ○	○ ○ ○ ○
X ● ●		LEM	X ○ ○	● ○ ○	7	7	X ● ○ ○ ○	○ ○ ○ ○
X ● ●		S ₀	X ○ ○	● ○ ○	8	8	X ● ○ ○ ○	○ ○ ○ ○
X ● ●		S ₁	X ○ ○	● ○ ○	9	9	X ● ○ ○ ○	○ ○ ○ ○
X ● ●		S ₂	X ○ ○	● ○ ○	:	:	X ● ○ ○ ○	○ ○ ○ ○
X ● ●		S ₃	X ○ ○	● ○ ○	;	;	X ● ○ ○ ○	○ ○ ○ ○
X ● ●	ACK	S ₄	X ○ ○	● ○ ○	<	<	X ● ○ ○ ○	○ ○ ○ ○
X ● ●	ALT MODE	S ₅	X ○ ○	● ○ ○	=	=	X ● ○ ○ ○	○ ○ ○ ○
X ● ●		S ₆	X ○ ○	● ○ ○	∇	∇	X ● ○ ○ ○	○ ○ ○ ○
X ● ●	RUBOUT	S ₇	X ○ ○	● ○ ○	?	?	X ● ○ ○ ○	○ ○ ○ ○

MARKING - ● (HOLE)

SPACING - ○ (NO HOLE)

X-SEE TEXT

Figure 2-12. ASCII Code Functions and Paper Tape Arrangement, Pre-1967

Table 2-3. DEFINITIONS OF 1967 ASCII CODE SYMBOLS

NUL	<i>Null, or all zeros</i>	DC1	<i>Device control 1</i>
SOH	<i>Start of heading</i>	DC2	<i>Device control 2</i>
STX	<i>Start of text</i>	DC3	<i>Device control 3</i>
ETX	<i>End of text</i>	DC4	<i>Device control 4</i>
EOT	<i>End of transmission</i>	NAK	<i>Negative acknowledge</i>
ENQ	<i>Enquiry</i>	SYN	<i>Synchronous idle</i>
ACK	<i>Acknowledge</i>	ETB	<i>End of transmission block</i>
BEL	<i>Bell, or alarm</i>	CAN	<i>Cancel</i>
BS	<i>Backspace</i>	EM	<i>End of medium</i>
HT	<i>Horizontal tabulation</i>	SUB	<i>Substitute</i>
LF	<i>Line feed</i>	ESC	<i>Escape</i>
VT	<i>Vertical tabulation</i>	FS	<i>File separator</i>
FF	<i>Form feed</i>	GS	<i>Group separator</i>
CR	<i>Carriage return</i>	RS	<i>Record separator</i>
SO	<i>Shift out</i>	US	<i>Unit separator</i>
SI	<i>Shift in</i>	SP	<i>Space</i>
DLE	<i>Data link escape</i>	DEL	<i>Delete</i>

47. THE EBCDIC CODE.

The EBCDIC code is an eight-level code providing 256 bit combinations of control and text characters. Of these, some are used for control and the rest for text characters, as shown in table 2-4. The remainder are unassigned. The EBCDIC code is primarily a computer-to-computer format. It is used internally within the IBM 9020 en route computer, and, when the NADIN is implemented, it will be used for full-duplex interface between the NADIN concentrator at the ARTCC and the local IBM 9020, through a general purpose input (GPI) and general purpose output (GPO) adapter.

48. THE MOORE ARQ CODE.

A seven-level code for error correcting by ARQ is shown in table 2-5. As used on some AFTN circuits, including certain radioteletypewriter links, the ARQ coding consists of a seven-unit code that always consists of exactly three marking signals and four spacing

signals per character. The normal five-unit Baudot code is converted, per character, to the seven-unit Moore format for transmission. Of the 128 possible code combinations, only the 35 that contain exactly three marking signals (1's) are valid. Because a single error in transmission will change the number of 1's to either 2 or 4, all single-error occurrences will be detected. All odd numbers of errors will be detected. However, this code will detect only those even-numbered error occurrences that have no transposition of 1's and 0's. The transmission speed is relatively slow, because each character is transmitted, stored, and evaluated, and a feedback signal sent to the sending terminal requesting the next character out of storage if no error was detected. If an error occurred, the character containing the error is repeated until it arrives error-free.

49. RESERVED.

Table 2-4. EBCDIC Code Format

Function	Bit Configuration	Function	Bit Configuration	Function	Bit Configuration	Function	Bit Configuration
NULL	0000 0000	b (blank)	0100 0000		1000 0000		1100 0000
	0000 0001		0100 0001	a	1000 0001	A	1100 0001
	0000 0010		0100 0010	b	1000 0010	B	1100 0010
	0000 0011		0100 0011	c	1000 0011	C	1100 0011
PF	0000 0100		0100 0100	d	1000 0100	D	1100 0100
HT	0000 0101		0100 0101	e	1000 0101	E	1100 0101
LC	0000 0110		0100 0110	f	1000 0110	F	1100 0110
DEL	0000 0111		0100 0111	g	1000 0111	G	1100 0111
	0000 1000		0100 1000	h	1000 1000	H	1100 1000
	0000 1001		0100 1001	i	1000 1001	I	1100 1001
	0000 1010	¢	0100 1010		1000 1010		1100 1010
	0000 1011	.	0100 1011		1000 1011		1100 1011
	0000 1100	<	0100 1100		1000 1100		1100 1100
	0000 1101	(0100 1101		1000 1101		1100 1101
	0000 1110	+	0100 1110		1000 1110		1100 1110
	0000 1111	!	0100 1111		1000 1111		1100 1111
	0001 0000	&	0101 0000		1001 0000		1101 0000
	0001 0001		0101 0001	j	1001 0001	J	1101 0001
	0001 0010		0101 0010	k	1001 0010	K	1101 0010
	0001 0011		0101 0011	l	1001 0011	L	1101 0011
RES	0001 0100		0101 0100	m	1001 0100	M	1101 0100
NL	0001 0101		0101 0101	n	1001 0101	N	1101 0101
BS	0001 0110		0101 0110	o	1001 0110	O	1101 0110
IDL	0001 0111		0101 0111	p	1001 0111	P	1101 0111
	0001 1000		0101 1000	q	1001 1000	Q	1101 1000
	0001 1001		0101 1001	r	1001 1001	R	1101 1001
	0001 1010	!	0101 1010		1001 1010		1101 1010
	0001 1011	¢	0101 1011		1001 1011		1101 1011
	0001 1100	.	0101 1100		1001 1100		1101 1100
	0001 1101)	0101 1101		1001 1101		1101 1101
	0001 1110	:	0101 1110		1001 1110		1101 1110
	0001 1111	;	0101 1111		1001 1111		1101 1111
	0010 0000	-	0110 0000		1010 0000		1110 0000
	0010 0001	/	0110 0001		1010 0001		1110 0001
	0010 0010		0110 0010	s	1010 0010	S	1110 0010
	0010 0011		0110 0011	t	1010 0011	T	1110 0011
BYP	0010 0100		0110 0100	u	1010 0100	U	1110 0100
LF	0010 0101		0110 0101	v	1010 0101	V	1110 0101
EOB	0010 0110		0110 0110	w	1010 0110	W	1110 0110
PRE	0010 0111		0110 0111	x	1010 0111	X	1110 0111
	0010 1000		0110 1000	y	1010 1000	Y	1110 1000
	0010 1001		0110 1001	z	1010 1001	Z	1110 1001
	0010 1010		0110 1010		1010 1010		1110 1010
	0010 1011		0110 1011		1010 1011		1110 1011
	0010 1100	•	0110 1100		1010 1100		1110 1100
	0010 1101		0110 1101		1010 1101		1110 1101
	0010 1110	>	0110 1110		1010 1110		1110 1110
	0010 1111	~	0110 1111		1010 1111		1110 1111
	0011 0000		0111 0000		1011 0000	0	1111 0000
	0011 0001		0111 0001		1011 0001	1	1111 0001
	0011 0010		0111 0010		1011 0010	2	1111 0010
	0011 0011		0111 0011		1011 0011	3	1111 0011
PN	0011 0100		0111 0100		1011 0100	4	1111 0100
RS	0011 0101		0111 0101		1011 0101	5	1111 0101
UC	0011 0110		0111 0110		1011 0110	6	1111 0110
EOT	0011 0111		0111 0111		1011 0111	7	1111 0111
	0011 1000		0111 1000		1011 1000	8	1111 1000
	0011 1001		0111 1001		1011 1001	9	1111 1001
	0011 1010		0111 1010		1011 1010		1111 1010
	0011 1011	#	0111 1011		1011 1011		1111 1011
	0011 1100	@	0111 1100		1011 1100		1111 1100
	0011 1101		0111 1101		1011 1101		1111 1101
	0011 1110		0111 1110		1011 1110		1111 1110
	0011 1111		0111 1111		1011 1111		1111 1111

Table 2-5. MOORE ARQ CODE FORMAT WITH FIVE-LEVEL BAUDOT CODE

Alphabet			S T A R T	5-Unit Baudot Code Elements					S T O P	7-Unit Moore ARQ Code						
Numbers	Letters Case	Figures Case		Bit Numbers						Bit Numbers						
				1	2	3	4	5		1	2	3	4	5	6	7
1	A	—	0	1	1	0	0	0	1	0	0	1	1	0	1	0
2	B	?	0	1	0	0	1	1	1	0	0	1	1	0	0	1
3	C	:	0	0	1	1	1	0	1	1	0	0	1	1	0	0
4	D	WRU	0	1	0	0	1	0	1	0	0	1	1	1	0	0
5	E	3	0	1	0	0	0	0	1	0	1	1	1	0	0	0
6	F	unassigned	0	1	0	1	1	0	1	0	0	1	0	0	1	1
7	G	unassigned	0	0	1	0	1	1	1	1	1	0	0	0	0	1
8	H	unassigned	0	0	0	1	0	1	1	1	0	1	0	0	1	0
9	I	8	0	0	1	1	0	0	1	1	1	1	0	0	0	0
10	J	aud. sig.	0	1	1	0	1	0	1	0	1	0	0	0	1	1
11	K	(0	1	1	1	1	0	1	0	0	0	1	0	1	1
12	L)	0	0	1	0	0	1	1	1	1	0	0	0	1	0
13	M	.	0	0	0	1	1	1	1	1	0	1	0	0	0	1
14	N	,	0	0	0	1	1	0	1	1	0	1	0	1	0	0
15	O	9	0	0	0	0	1	1	1	1	0	0	0	1	1	0
16	P	0	0	0	1	1	0	1	1	1	0	0	1	0	1	0
17	Q	1	0	1	1	1	0	1	1	0	0	0	1	1	0	1
18	R	4	0	0	1	0	1	0	1	1	1	0	0	1	0	0
19	S	'	0	1	0	1	0	0	1	0	1	0	1	0	1	0
20	T	5	0	0	0	0	0	1	1	1	0	0	0	1	0	1
21	U	7	0	1	1	1	0	0	1	0	1	1	0	0	1	0
22	V	=	0	0	1	1	1	1	1	1	0	0	1	0	0	1
23	W	2	0	1	1	0	0	1	1	0	1	0	0	1	0	1
24	X	/	0	1	0	1	1	1	1	0	0	1	0	1	1	0
25	Y	6	0	1	0	1	0	1	1	0	0	1	0	1	0	1
26	Z	+	0	1	0	0	0	1	1	0	1	1	0	0	0	1
27	Car. Ret.		0	0	0	0	1	0	1	1	0	0	0	0	1	1
28	Line Feed		0	0	1	0	0	0	1	1	0	1	1	0	0	0
29	Letters		0	1	1	1	1	1	1	0	0	0	1	1	1	0
30	Figures		0	1	1	0	1	1	1	0	1	0	0	1	1	0
31	Space		0	0	0	1	0	0	1	1	1	0	1	0	0	0
32	Blank		0	0	0	0	0	0	1	0	0	0	0	1	1	1
33	Signal Repetition									0	1	1	0	1	0	0
34	Signal α									0	1	0	1	0	0	1
35	Signal β									0	1	0	1	1	0	0

Notes: Transmission Order: Bit 1 - Bit 5
 "0": Spacing element (no current)
 "1": Marking element (positive current)

Subsection 3. SELECTIVE SIGNALING

50. SELECTIVE CALLING.

This discussion applies, primarily, to the M28 equipment. Because the M35 and M37 equipments are not currently used in a switched-message network, selective calling and associated stunt box functions are not applicable. Theory of the stunt box mechanism for the

M35 and M37 is located in the M35 and M37 instruction manuals (Teletype Corporation Bulletins) identified in Appendix 4 of this order; the publications applicable to the typing units (LP and YP) contain this information. Appendix 5 of this order is the stunt box arrangement for the M28. A similar illustration for the

M35 is the figure in paragraph 3.44 of section 574-220-700TC, Volume I, of the FA-7938 Model ASR-35 instruction book. For the M37 stunt box, see figure 13, section 574-320-01TC, YP description and principles of operation.

a. **General.** The M28 printer operates in three basic functional modes:

(1) The first mode is referred to as **LETTERS**. In this mode the printer types alphabetical characters and performs functions as indicated on the lower portion of the printer's green keytops.

(2) When the typebox shifts to **FIGURES**, the second area, symbols and numerical characters as indicated on the keytops will be printed.

(3) In the third mode, **SELECT-NONPRINT**, direct printing is suppressed while the signal selector and stunt box actively monitors the circuit. This last mode of operation, under which selective calling is performed, will be described in brief form. A complete technical description is beyond the scope of this order and will not be attempted.

b. **Stunt (Function) Box.**

(1) There are many different methods of utilizing the stunt box. Some make use of conditions codes, some use single character directing codes, and others use two or more characters in a predetermined sequence. Used with and without conditioning codes, sequential character directing code callups are among the most valuable features provided by the stunt box; and a general example will be presented without evoking the amount of detail already provided in the equipment specification.

(2) Generally, a sequential code directing call (CDC) can be used without a conditioning code, if the sequence of characters does not occur as a valid combination used in the particular system under consideration. Since such possible combinations are necessarily limited in number, one of them is usually employed as a conditioning code to "open a gate." During the time the gate is open, many CDC's composed of combinations that may also be employed elsewhere in the data or message traffic, can be utilized. A further automatic convention, a character or sequence of characters, is used to decondition or "close the gate" so that regular system operation can continue without activating the automatic controls associated with the CDC's. A CDC can be used for many purposes: To call in a printer or a reperforator, to start a transmitter-

distributor, to actuate relays controlling lights, motors, emergency power supplies, etc. The CDC accomplishes this by causing the operation of a form C (one swinger, one front, one back contact) contact assembly mounted on the stunt box.

(3) **Sequential Selection.** Sequential selection is the most useful feature of the stunt (function) box, and latching-unlatching is the key to sequential selection. Sequential selection is defined as selection on, and only on, and is a specific group of characters arranged in a particular order and time. For the purposes of this discussion, "character" is used to include both printable and nonprintable teletypewriter operations.

(4) **Coding the Stunt Box** (figures 2-13 and 2-14). Blocking and latching type function levers permit a function to be performed when a sequence of two or more characters is received by the teletypewriter. To illustrate the principle of sequential selection, assume that a function is to be performed upon receipt of the sequence, carriage return (CR), line feed (LF), and letters (LTR), in that order only. In order to accomplish this, three consecutively numbered slots in the stunt box must be used. The first, or lowest numbered, slot is then equipped with a function bar coded for carriage return, a standard function pawl, a function lever with both a blocking projection and a latching projection, and a function latch with an unlatching projection operated by the stripper blade. Function bar, pawl, and lever extension springs must also be used to complete the function mechanism in this slot. The second, or adjacent higher numbered, slot is equipped with an identical set of parts except that the function bar is coded for line feed. The third, or highest numbered of the three slots is equipped with a function bar coded for letters, a standard function pawl, a function lever without either blocking or latching projections, and a spring plate, plus the associated extension springs.

(5) **Stunt box operation for CR LF LTR coding setup.**

(a) When a carriage return character is received by the teletypewriter, the code bars are positioned to correspond to the carriage return code. As the function bar reset bail moves forward, the function bar in the first slot is pulled forward by its spring and finds an opening in the code bars opposite each tine on the function bar. The function bar in the second slot is blocked from moving forward by the code bars. (If a line feed is received, but not immediately preceded by a carriage return, this function bar will be blocked by the blocking projection on the function lever in the first slot.) As the reset bail moves to the rear, the se-

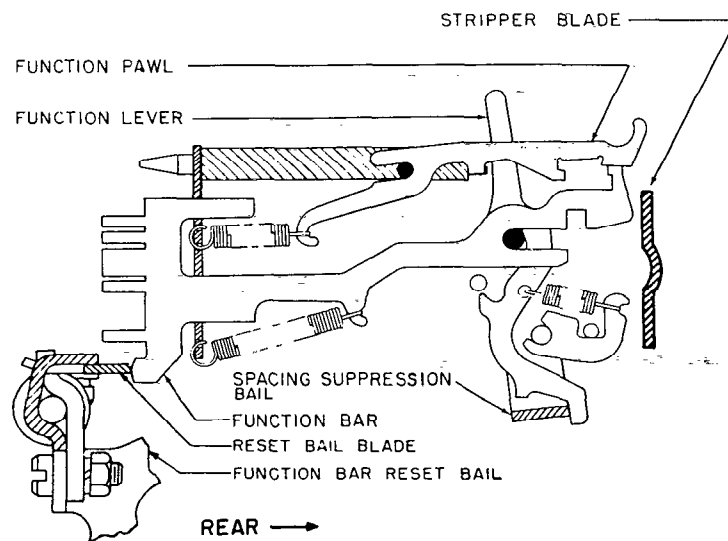

A. UNOPERATED

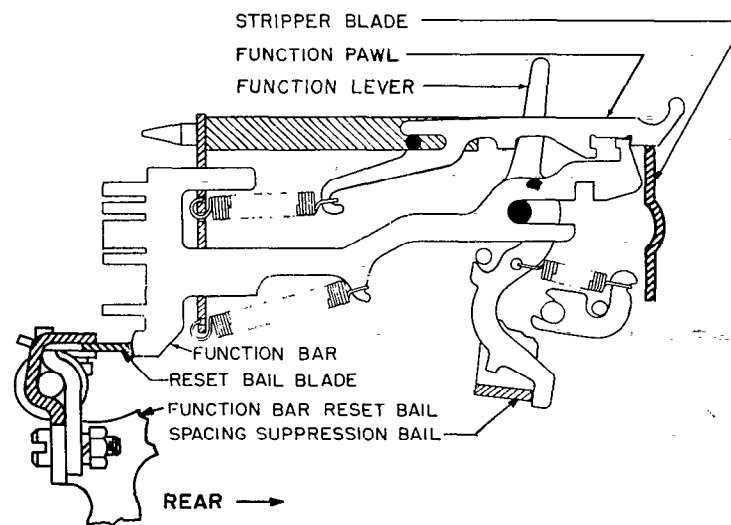

B. OPERATED

Figure 2-13. Function Box Mechanism

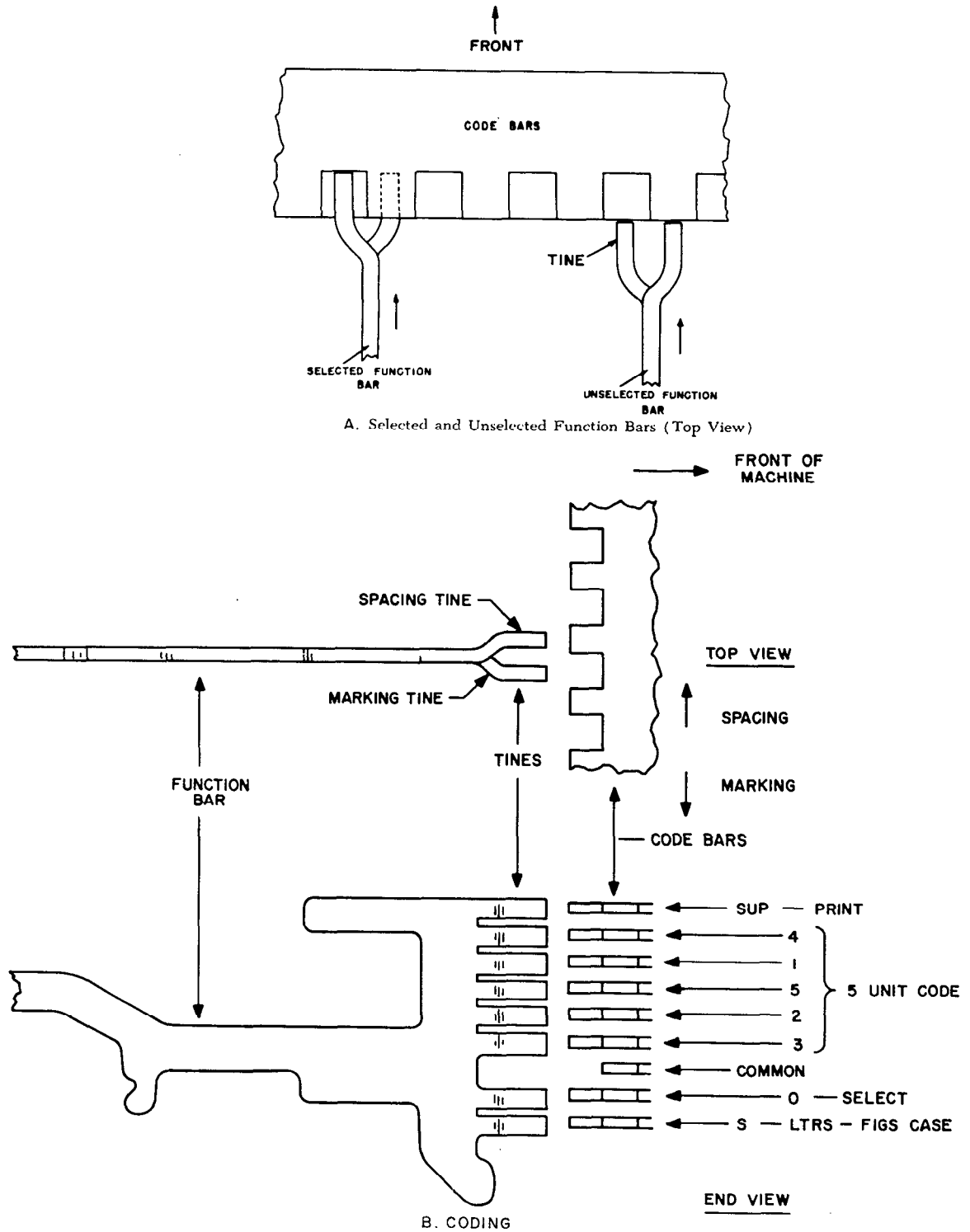

Figure 2-14. Code Bars-to-Function Bar Tines Relationship

lected function pawl in the first slot is moved to the rear by its function bar. The pawl rotates its associated function lever clockwise and the lever is latched in its operated position by the latch plate. This removes the blocking projection on the lever from the path of the function bar in the second slot so that this function bar is now unblocked. When the stripper blade rises and unlatches the function pawl in the first slot, the function lever remains latched in its operated position and the function bar in the second slot remains unblocked.

(b) If the next character is not a line feed, the function bar in the second slot will not be selected and when the stripper blade moves downward during this cycle, it will unlatch the function in the first slot and restore it to its normal unselected position. However, if the next character is a line feed, the function bar in the second slot will be selected and the function lever in this slot will be operated and latched in its operated position by the latch plate. This unblocks the function bar in the third slot. During this cycle of operation, the function lever in the first slot will be unlatched but only after the function bar in the second slot has been selected.

(c) If the third character is not letters, the function bar in the third slot will not be selected, the function lever in the second slot will be unlatched during this cycle of operation, and the function mechanisms in the first and second slots will both be restored to their normal unoperated positions. However, if the third character is letters, the function bar in the third slot will be selected and the function lever in this slot will be rotated clockwise when the function bar and pawl are moved to the rear. The standard function lever and spring plate in this slot can be replaced by a latch-unlatch or latch-release type of function mechanism if desired. Consequently, momentary operation of the contacts or desired function, lock-up the contacts or desired function, and unlock of the contacts or desired function is made available as required for the particular application of the CDC. Technical part nomenclature and operating theory of the M28 printer will be found in Teletype Corporation Bulletins 216B, Description and Theory; and 1149B, Parts, M28.

51. OPERATION OF A PRINTER FUNCTION.

a. The basic operation performed by the stunt box is the initiation of functions within the printer. Assume that line feed is the function to be performed. When the code combination for line feed is received by the signal selector of the page printer, the line-feed combination is set up in the code bars. When the function

clutch is tripped following the selection cycle, all the function bars in the stunt box follow the function bail forward and feel for an opening in the code bars. In this case, a free path is found only by the function bar containing the line-feed code.

b. Entry into the code bars permits the function bar to travel forward far enough to allow its associated function pawl to become engaged with the function bar. The function bar, actuated by the function bail, then carries the function pawl rearward. The function pawl in turn engages its companion function lever which, through a suitable mechanism, trips the line-feed clutch to perform the line-feed function. The function pawl is then disengaged from the function bar by the stripper blade and the operation is completed. It should be noted that the lower projection of the function lever engages the space suppression bail and pushes the bail forward to suppress spacing. This extension of the function lever is omitted when spacing on a function is desired.

52. SEQUENTIAL SELECTION OF A FUNCTION.

a. Selection of a function can be accomplished on a sequential basis by using a sequence of code combinations. Assume that it is desired to perform a function upon reception of a two-character code sequence consisting of FIGURES-J. Further assume that final operation of the function is to be performed only when the sequence is received in proper order without the interposition of another character. In this case, two function-bar mechanisms must be provided in addition to those required for the regular functions. In other words, the figures function bar mechanism employed in the shift operation cannot be reemployed in this special function sequence.

b. This sequential method of selection can be expanded to any practicable limit; that is, the sequence of code combinations required to perform the desired operation can be made in any desired order. In effect, the first function bar mechanism of a sequence opens a gate for the function bar mechanisms to the right (as viewed from the rear) for the following cycle only, and then immediately closes the gate unless the next function bar takes advantage of the opening. Therefore, unless the sequence is selected in exact order, the desired operation will not be performed. By using a sequence of code combinations not ordinarily encountered in a message text, local and remote functions can be performed without sacrificing character code combination.

53. CONTROL OF REMOTE APPARATUS.

a. Remote control of auxiliary apparatus such as reperforators, indicating lamps, signal bells, motor controls, etc., may be accomplished by the addition of electrical switches to the stunt box. These switches are assembled in molded plastic blocks which will accommodate four switch mechanism. The stunt box will accommodate 8 blocks or a total of 32 switch mechanisms.

b. Each switch contains an arm, a contact, and a spring. Electrical contact is completed between the arm and the contact. Wiring connection is made to the contact and to the spring.

c. Each switch mechanism controlled by the top of a function lever, may be either normally open or normally closed. Operation of the function lever associated with the switch arm either opens or closes the contact pair. A break-before-make or make-before-break transfer may be obtained by employing two function bar mechanisms and two associated switch mechanisms.

d. These electrical switches may, of course, be operated whether on a single-character code or a sequential basis. Also, the switch may be operated and returned to normal during the character cycle or it may be locked either closed or open.

54. MESSAGE CODING.

a. **General.** In order to achieve certain functions related to message routing and handling, it is necessary to use the following teletypewriter character symbols. These character symbols will be arranged in code groups to accomplish the selecting calling function required:

< Carriage return
 ↓ Letters
 ≡ Line feed
 ↑ Figures
 → Space

b. **Code Groups and Their Purpose.** These code groups are representative of groups used by service B, BDIS circuits and are not necessarily the same, nor mean the same, as ones used for the other service B AFTN, and WMSC networks. For detailed information on formatting, routing, and calling sequences, refer to the latest edition of Order 7110.10, part II, Flight Services Handbook.

(1) Condition Code (<<↓) causes the equipment to recognize the code group that is immediately following it.

(2) CDC is a three-or four-character code used to route and deliver a message to a particular terminal. (Also referred to as a select code.)

(a) Four-character codes beginning with X start reperforators at the low-speed relays (RT sets).

(b) Three character codes beginning with figures (↑) plus the last two figures of a circuit number is used to divert traffic to an area circuit when failure occurs on a supplemental circuit.

(3) Transmitter start code (TSC) is a two-or three-character code used to activate transmitters.

(4) Alignment code (<<≡) is a code following each CDC or collective code which provides left-hand margin sequencing of addresses.

(5) End-of-line code (EOL) (<<≡) terminates intervening lines of a multiline message.

(6) End-of-text (EOT) (↓<<≡) terminates the last line of text of a message.

(7) End-of-message code (EOM) (NNNN) terminates the copying of a message by a particular piece of equipment. Message switching centers require this to control internal processing and relaying. In addition, the M-28 printer must also be capable of recognizing LF-CR-LTRS (≡<↓) as a valid EOM.

c. **Non-Printing Function Codes.** The following examples illustrate the use of codes to accomplish certain functions. The example codes used in this part are further identified as:

A - Condition Code
 B - Call Directing Code
 C - Alignment Code
 D - Special Condition
 E - End of Message Code

(1) Message-to-station on same circuit (single address):

$\frac{\ll\downarrow}{A} \frac{AUS}{B} \frac{\ll\equiv}{C} \text{MESSAGE} \frac{NNNN}{E}$

(2) Message-to-station on same circuit (two addresses):

$\frac{\ll\downarrow}{A} \frac{AUS}{C} \frac{\ll\equiv}{C} \frac{\ll\downarrow}{A} \frac{SAT}{B}$

<<≡ MESSAGE NNNN
 C E

NOTE: In the above examples, the word "message" includes line feeds before the message, the preamble, the text, the signature, and the line feeds that follow.

55. OPERATION OF RELAY CONTROL GROUP.

a. General. The following are the features required of the Relay Control Group (refer to figure 24 in Order 6170.4, and M28 ASR Wiring Schematic IMD-D-439).

(1) Prevent automatic sending into either an open or busy line.

(2) Retain a start-request until an idle line condition exists.

(3) Provide a "start-ground" for the transmitter-distributor when:

- (a) Tape is waiting to be sent, and
- (b) Line is neither busy nor open, and

(c) A start-request is received from either a function box contact or a manual pushbutton. The various components that are associated with the different combinations of this relay control group are described individually.

b. Standby Condition of Circuit. In the standby or idle circuit condition, no pulses being received, the line relay is operated to mark, causing the selector magnet to be held closed and the open line relay to be operated. With no tape awaiting transmission in the transmitter-distributor, the tight tape switch will be closed while the end-of-tape switch contacts are open.

c. Busy Line Condition of Circuit.

(1) Both the busy line relay (BL) and the open line relay (OL) are slow release relays, having a release time of a maximum of 5 character lengths (500ms) at 100wpm. In effect, these relays cannot follow the signal line pulses delivered by the line relay, but once operated they remain in the energized position for a minimum of the release time. Because of this characteristic, the BL relay operates on the first spacing pulse received from the line relay, and remains operated until transmission ceases on the signal line.

(2) The OL relay is normally operated in that it performs its useful circuit function upon releasing. During signal transmission the OL relay remains operated, and releases only when a line break of a greater duration than three character lengths exists.

(3) The BL relay, operating its break contacts 1 and 2, removes the operating ground from the start relay (ST), so that if a request-to-start signal is received at that moment, no signal could be sent to the sensing clutch magnet. To make contacts 3 and 4 provide a voltage return for the busy line lamp, which burns as an indication of line condition to the keyboard operator. With transmission ends, and after a pause of approximately 500ms, the BL relay releases, thereby restoring the operating ground to the automatic control circuit and extinguishing the BL lamp.

d. Open Line Condition of Circuit. The open line (OL) relay, because of its slow release characteristic, has not been released during reception of line signals through the line relay; however, the OL relay will release when the line relay remains spacing for a minimum of approximately 300ms, as would occur in case of a defective signal line or a received-line break from another station. When the OL relay releases, the transfer contacts 3, 4, and 5, remove the return path of the 5.5V ac BL lamp circuit so that it cannot burn; meanwhile, these contacts provide the 5.5V ac return for the OL lamp which burns in a blinking manner. The OL lamp blinks, because it is in series with a thermal flasher device to indicate to the attendant that an open line condition exists. To make contacts, 6 and 7, remove the lockup (operate) ground from the Start Relay: thus, preventing the transmitter-distributor from operating had tape been in it. Contacts, 1 and 2, cause request-to-start relay (RS-1) to deenergize; therefore, preventing the transmitter-distributor from transmitting when the signal line is restored to normal. A request-to-start must be initiated after the signal line is restored to normal in order for the transmitter-distributor to again operate. Contacts 3 and 4 make, completing the circuit to the open line light.

e. Transmitter-distributor Sending. The origination of an automatic transmitter-distributor sending cycle is considered to be the time the attendant places tape in the tape gate of the desired transmitter-distributor. At this time, the end-of-tape contacts close and prepare the relay group to operate by providing battery for relays ST and RS-1. At this point, a request to start is required and may be furnished from either:

(1) Manual start pushbutton (if during an uncontrolled portion of the circuit operation), or

(2) Function box contacts K-10 or K-17 (if during a scan controlled portion of the circuits operation).

f. Manual Start of the Transmitter-Distributor During an Idle Line.

(1) During an idle line, a manual start may be initiated by inserting a tape in the transmitter-distributor and depressing the start switch. With tape in the transmitter-distributor, -48 volts is applied through the EOT contacts, tight tape (TT) contacts, transmitter stop switch, LSU 129 to the top of both the RS-1 (request to start relay) and ST relay. Depressing the transmitter start switch applies ground to the RS-1 relay, which energizes; its contacts 1 and 2 close providing an operate ground through K-8 EOM contacts. Contacts 3 and 4 of RS-1 make, providing a ground through 1 and 2 of the BL relay to the coil of the ST relay which now energizes; the ST relay contacts 4R and 6R close and provide a holding ground through 6 and 7 of the OL relay. Contacts 2L and 3L of the ST relay make, ensuring that the off-line solenoid is energized, so the printer will copy the outgoing message of the transmitter-distributor. Contacts 4L and 5L of the ST relay make, providing a ground for the sensing clutch magnets, which now energize. At the time that the sensing cam sleeve assembly has rotated 270 degrees, Auxiliary "B" closes, allowing the distributor cam sleeve to commence rotating. The start-stop contacts on the distributor block now open to generate the start (space) pulse. Immediately, the BL relay energizes; its contacts 1 and 2 open; however, the ST relay remains energized through its own contacts 4R and 6R to contacts 7 and 6 of the OL relay. Contacts 3 and 4 of the BL relay make, completing the circuit to the BL light.

(2) Once the transmitter-distributor is operating, there are various ways to stop it. Upon completion of the message being transmitted, the EOT contacts will open, removing the -48 volts from the RS-1 and ST relays, causing them to deenergize. Manually depressing the transmitter stop switch would have the same effect as previously mentioned. A tangled or taut tape would cause the TT contacts to open, again stopping the transmitter-distributor.

g. Open Line During Transmission. To simulate an open line condition during the time the transmitter-

distributor is operating, depress and hold in the line break button for more than three character lengths. During the time the transmitter-distributor is operating, the following relays are energized: BL, OL, ST, and the RS-1. After the signal line has been "open" in excess of 300ms, the OL relay will deenergize; its contacts 6 and 7 will break allowing the ST relay to deenergize. The ST relay contacts 4L and 5L "breaking" remove ground from the sensing clutch magnets, which now deenergize allowing the transmitter-distributor to stop. Contacts 3 and 4 of the OL relay make, allowing the open line light to come on. Contacts 1 and 2 of the OL relay make, placing a shunt across the RS-1 relay, allowing it to deenergize; once the signal line is restored, the transmitter-distributor will not start again without initiating a request to start.

h. Stunt Box Callup. When tape has been inserted in the transmitter-distributor, -48 volts is applied to the ST and the RS-1 relays. Upon reception of the conditioning code, followed by the transmitter-distributor call, K-10 or K-17 closes providing a start ground for the RS-1 relay. Its contacts 1 and 2 close providing an operate ground through K-8 for the RS-1 relay. Contacts 3 and 4 of RS-1 relay make and apply ground to contact 1 of BL relay. Contacts 1 and 2 of the BL relay are open for 500ms after the callup, at which time the BL relay deenergizes, closing 1 and 2 completing the ground to the bottom of the ST relay, which now energizes. The relays will operate as previously outlined in paragraph 55f.

i. Printer Callup. In remote, assume the off-line solenoid is deenergized. Upon reception of the conditioning code followed by the printer call, K-20 or K-23 close to provide a ground to energize the dc control relay. Its contacts 1 and 2 close providing a ground return back through K-8 in the stunt box. The micro-switch contacts close applying 117 volts ac to the off-line solenoid which energizes, taking the printer out of suppression. The printer will now copy all traffic on the line until the EOM is received, which is NNNN or LF CR LTR. The EOM code will cause K-8 to open and remove the ground from the dc control relay to allow it to deenergize. The off-line solenoid will deenergize and place the printer back in suppression.

56.-59. RESERVED.

Subsection 4. SIGNALS, DISTORTION, AND DISTORTION ANALYSIS

60. BAUDS AND BITS.

A parameter of importance in data handling circuits is the rate of information flow. It is measured in bit

rate. There are a number of methods for signaling in pulse-type systems. In some of these, the actual signaling speed may not be equal to the number of bits of

information transmitted over the circuit in the same time period. The term baud refers to the modulation rate, that is, the number of different signal conditions on the line per second. It is not information rate; that is the role of the bit rate. The American National Standards Institute (ANSI) defines bauds and bits as follows:

a. **Baud.** A unit of signaling speed equal to the number of discrete conditions of signal events per second. For example, one baud equals one-half dot cycle per second in Morse code, one bit per second in a stream of binary signals, and one three-bit value per second in a train of signals each of which can assume one of eight different rates. Calculate bauds by dividing 1 by the time duration of the bit, which is the smallest signal element on the line.

b. **Bit.** A *binary digit*, a unit of measurement of quantity of information equal to that contained in a message represented by one or the other of two equally probable, exclusive, or exhaustive states (e.g. "1" or "0", "mark" or "space").

61. SIGNALING SPEED.

Signaling speed is an important parameter for a communication data channel and it is determined by channel capacity and bit rate. It is possible to have a data-handling system in which the baud rate is many times the bit rate; the system will be handling information in terms of bit rate, and its signaling speed will be in terms of bauds. In the data-handling systems covered by this order, the serial bit rate is nominally equal to the baud rate in both the five-level Baudot and eight-level ASCII codes. Signaling speed can be computed by the following formula:

$$\text{Signaling speed} = \frac{\text{words per minute} \times \text{bits per character} \times \text{characters per word}}{60}$$

Substituting data for the five-level Baudot code at 100wpm:

$$\text{Signaling speed} = \frac{100 \times 7.42 \times 6}{60} = 74.2 \text{ bauds (called 75 bauds)}$$

Substituting data for the eight-level ASCII code at 100wpm:

$$\text{Signaling speed} = \frac{100 \times 11 \times 6}{60} = 110 \text{ bauds (also 110bps)}$$

Note that bits per character in the Baudot code is a number consisting of one start bit, five intelligence bits, and one stop element that is 1.42 times the duration of the other bits: 7.42 total. In the ASCII format, there is one start bit, seven intelligence bits, one parity bit, and two stop bits, all of equal duration: 11 total. Characters per word are assumed by using five text characters and one space character for a total of six. Table 2-6 compares the signaling parameters of several kinds of data handling equipments and coding schemes.

62. SIGNAL DISTORTION.

This order discusses signal distortion as it affects a dc "telegraph" signal. The distortion affecting ac signaling, such as is encountered in frequency-division multiplex (fdm) and carrier channels, and which includes delay, envelope delay, frequency attenuation, and harmonic distortion, is beyond the scope of this order.

Table 2-6. COMPARISON OF SIGNALING SPEED BY EQUIPMENT AND TRANSMISSION CODE

Equipment	Unit Code and Code Level	Words per Minute	Pulse Duration (ms)		Signaling Speed		Bauds or Modulation Rate
			Start and Code Pulses	Stop or Rest Pulse	Characters per Second	Characters per Minute	
M28	7.42/5 Baudot	60 (61.33)	22	31	6.13	368	45.45
M28	7.42/5 Baudot	75 (76.67)	17.57	25	7.67	460	56.88
M28	7.42/5 Baudot	100	13.47	19.13	10	600	74.2 (75)
M35	11/8 ASCII	66.67	13.64	27.72	6.67	400	73.33
M35	11/8 ASCII	100	9.09	18.18	10	600	110
M37	11/8 ASCII	150	6.06	12.12	15	900	165

a. **Ideal Signal.** The ideal transmitted signal would consist of equal-length pulses, mark and space, as shown in figure 2-19 part A. This ideal pulse, practically speaking, is never transmitted or received. It suffers at least some distortion both in the transmitting mechanism, in the medium of transmission, and in the receiving selector mechanism.

b. **Telegraph Distortion.** The five major forms of dc signal distortion are: bias, end, characteristic, fortuitous, and speed distortion. Figure 2-19 parts B through H illustrate some of these forms of distortion. They are described in the following subparagraphs.

(1) **Bias Distortion.** Bias distortion is defined as the average displacement of the SPACE-TO-MARK (S-M) transitions from their theoretically correct positions. If the transition occurs early, it results in marking bias, i.e., the marking signal pulses are too long. If the transition is late, the resultant bias is spacing, and the time length of the space pulses is too long.

(2) **End Distortion.** End distortion is the average time displacement of the MARK-TO-SPACE transitions relative to the first M-S transition (start-pulse). If the transition is early, it lengthens the following space interval and is called spacing end distortion. If the transition is late, it lengthens the mark interval and is called marking end distortion.

(3) **Characteristic Distortion.** Characteristic distortion depends upon the parameters of a circuit, the speed of transmission, and the "history" of the signals preceding the one under observation. If the parameters of the circuit are such that the time to reach steady state exceeds the time length of a unit pulse, a following unit pulse signal will be shorter than its normal length (i.e., with a mark-mark-space-mark-space-signal, the first space-pulse can be extended or shortened). Characteristic distortion is usually encountered on electrically long circuits and on carrier circuits where the bandwidth of the channel is narrow in proportion to the signaling frequency.

(4) **Fortuitous Distortion.** Fortuitous is the random displacement of the signal transition point and may occur on either the M-S or the S-M transition. It is found on long radio circuits and on any telegraph channel subject to "cross-talk" from other telegraph channels or power circuits.

(5) **Speed Distortion.** Speed distortion is the time displacement of signal transitions due to incorrect operating speed of the sending device. The amount of speed distortion is uniformly cumulative during a

single character and is maximum on the final transition.

(6) **Margin Range.** Distortion of any type will affect the range of the receiving equipment. Spacing bias reduces the lower end of the teletypewriter range, and marking bias reduces the upper range (e.g., if receiving equipment had a range of 20 to 100 on range scale and experienced 20 percent spacing bias, then the range would be reduced to 40 to 100). Characteristic distortion affects the range similar to bias distortion, but for bias distortion, the failure point on the margin scale is sudden and quickly discernible. For characteristic distortion the failure band is wide and difficult to locate due to the dot frequency effect of different characters. The spacing end distortion will reduce the lower margin limit. Since fortuitous distortion produces bias distortion and end distortion, it will reduce both ends of the margin range equally. Fortuitous distortion causes transition shifts in a random manner, and it is difficult to locate the exact point on the range scale where failure occurs. Where speed distortion is concerned, the range will show a 6 percent margin loss for each 1 percent of speed difference between sending and receiving devices. Therefore, if the speed difference is 3 cycles out of 60, or 5 percent, there would be a 30 percent margin loss.

63. DISTORTION ANALYSIS EQUIPMENT.

Several telegraph or digital distortion test sets (dts) are available at datahandling facilities for checking terminal equipment. These sets have been procured over a period of years, becoming more sophisticated as the associated equipment or systems are modernized. Some of the older dts are limited to asynchronous (start-stop) signals; the modern dts equipments will check up to 11-unit codes in both asynchronous and synchronous modes. Certain dts are comprised of both analyzer (receive-only) and pattern generator (transmit). One of the most modern has a capability of determining the error rate of a channel by sending a predetermined, pseudorandom pattern of bits and the receiver, in synchronism, records the bit or character error as they occur.

a. **Distortion Test Set Model DTS-531P.** The Communications Technology Model DTS-531P is a versatile distortion analyzer with the capability of accepting an external digital signal and artificially distorting it for transmission to a receiver equipment under test. It will accept a variety of input polar signals, at voltages from ± 6 volts to ± 60 volts, in a current range of $100\mu\text{A}$ to 30mA . Neutral inputs up to 60mA are accommodated. The input can be binary stream (synchronous) or in 5, 6, 7, or eight-level asynchronous

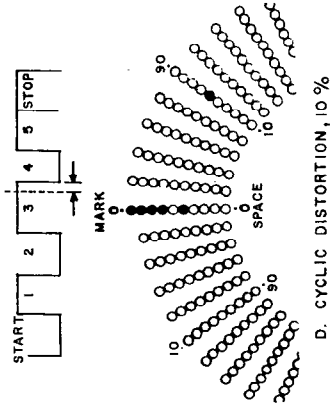

D. CYCLIC DISTORTION, 10%

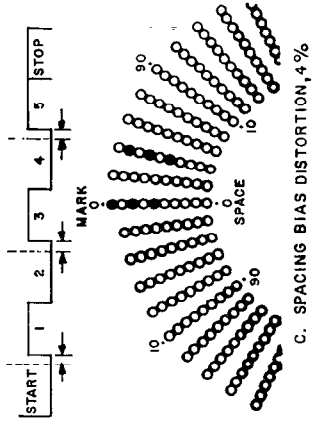

C. SPACING BIAS DISTORTION, 4%

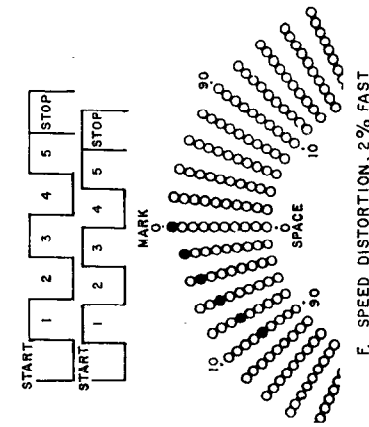

F. SPEED DISTORTION, 2% FAST

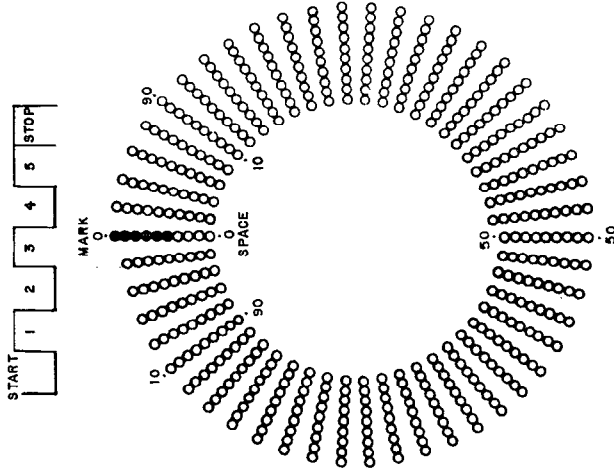

A. NON-DISTORTED CHARACTER DISPLAY.

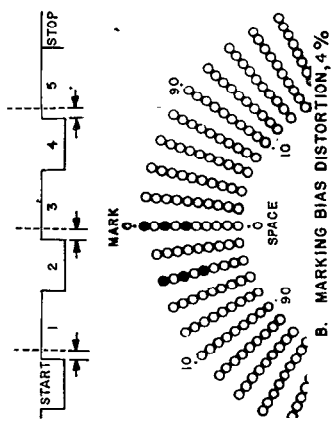

B. MARKING BIAS DISTORTION, 4%

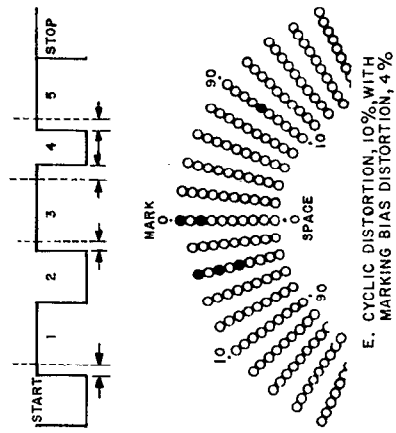

E. CYCLIC DISTORTION, 10% WITH MARKING BIAS DISTORTION, 4%

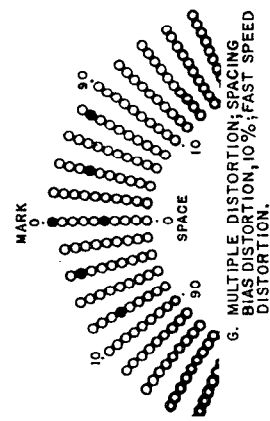

G. MULTIPLE DISTORTION; SPACING BIAS DISTORTION, 10%; FAST SPEED DISTORTION.

Figure 2-19. DTS-531P Distortion Patterns

modes. It will handle modulation rates at 37.5, 45.45, 50, 61.12, 75, 100, 150, 300, 600, 1200, 2400, and 4800 bauds. The display for distortion consists of a spiral array of light emitting diodes (LED) permitting a reading of distortion in increments of 2 percent in a range from 0 to 98 percent. Codes generated for transmission are the five-level start-stop Baudot and eight-level ASCII, as a "fox" test sentence with a programmable call sign, or a pyramid pattern, repetitive character, alternating characters, steady marking, or steady spacing. Distortion can be introduced into the transmitted test signal in the form of marking; spacing; switched bias, or end distortion, in 1 percent increments in a range from 0 to 79 percent. With the DTS-531P it is possible to determine the magnitude and type of distortion. The following are typical examples of that capability.

(1) Marking Bias Distortion (figure 2-19, item B). Marking bias distortion is indicated by the uniform displacement of all S-M transition indications appearing to the left of, or counterclockwise from, the zero position. Distortion is read in percentage, in 2 percent increments, on the outer scale of the display. Note that all M-S transitions occur at the proper instant with respect to the stop-to-start transition.

(2) Spacing Bias Distortion (figure 2-19, item C). Spacing bias distortion is indicated by the uniform displacement of all S-M transition indications appearing to the right of, or clockwise from, the zero position. Note that all M-S transitions occur at the proper instant with respect to the stop-to-start transition.

(3) Cyclic Distortion (figure 2-19, items D and E). Cyclic distortion is manifested by one or more bit transition indications within a character. This distortion may be superimposed on, or in addition to, other distortion characteristics accompanying the data as shown in figure 2-6, item E.

(4) Speed distortion (figure 2-19, item F). Speed distortion in the start/stop mode of operation is indicated when the display itself appears as a segment of a spiral. Speed distortion is created when a data stream is transmitted faster or slower than the correct modulation rate. Consequently, each bit transition within a character occurs progressively sooner or later than the preceding transition. As a new measurement is made on each individual character, the display will indicate a constant spiral segment for a given speed error. Figure 2-19, item F, shows distortion resulting from a fast input data rate. A spiral segment beginning at top center and running in the opposite direction from that shown indicates that the data rate is slow.

(5) Multiple Distortion Display (figure 2-19, item G and H). Data signals may be simultaneously affected by numerous types of distortion of various magnitudes. An example of spacing bias distortion and speed distortion in the start/stop mode is shown in figure 2-19, item G. An inspection of the display illustrated indicates the presence of two patterns. One pattern begins at zero and runs counterclockwise to approximately MARK 8, forming a spiral segment. A second pattern begins at SPACE 8 and runs counterclockwise to approximately zero, forming a second spiral segment. A spiral segment is indicative of speed distortion, while two spiral segments, removed from each other, are indicative of bias distortion in addition to speed distortion. As the spiral segments run counterclockwise from zero, the speed distortion is due to a fast input rate. It remains then to determine the type and percentage of bias distortion present. This is accomplished by turning the OSCILLATOR switch from the FXD position, and slowly varying the OSCILLATOR COARSE and FINE potentiometers R1A and R1B until a pattern exists similar to that internal clock rate to match the input data rate, thus, effectively eliminating distortion to be made. It can be seen that a spacing bias distortion of 10 percent exists. The two problems can now be solved individually. The transmitting station should be advised to check the speed of their transmitting device. When the speed error has been corrected, the source of the bias can be isolated and the circuit restored to undistorted operation.

b. **Pattern Generator Model PG-303A.** The Stelma PG-303A pattern generator provides output patterns of 5- and 8-level "Fox" messages, a pseudorandom pattern or a programmable 1 through 6 character sequence. The patterns can be a repetitive free-running serial data stream or can be stepped on a sequence, character, or bit (synchronous) basis. The output signal can be strapped to comply with interface criteria for low-level RS-232C or MIL STD-188C, high-level dry contact electronic relay contact closures (neutral or polar), and Bell System electronic hub. Various data speeds are provided from an internal crystal clock (37.5, 50, 61.12, 74.2, 75, 110, 134.5, 150, 300, 600, 1200, 2400, 4800, and 9600bps); an external 6-volt polar clock 200 times the desired bit rate; or other additional crystal clocks providing for any specified rate up to 9600bps.

c. **Data Analyzer Model DMS-303A.** The Stelma DMS-303A data analyzer is used to determine parity errors and distortion for any signal up to 9600bps. When used with the PG-303A pattern generator, it will also provide a bit error rate for system analysis. In distortion mode the data analyzer will measure end, bias,

and peak distortion. When registering peak distortion, it will hold the maximum meter reading for 5 seconds or until it is manually reset. The distortion measurement can be accomplished compositely on the entire data stream or on any selected-bit transition (1 through 9). In the bit error count mode, the analyzer compares the pseudo-random or reversal pattern received to an internally generated standard, to produce an error count over a preselected sample period (i.e., 10^2 , 10^3 , 10^4 , 10^5 , 10^6 , or infinite number of bits received). The accumulated error count is displayed on the front

panel meter. Parity errors are indicated by the parity error lamp during distortion measurements; or they can be counted and displayed on the meter, similar to bit errors, during the parity error mode of operation. The analyzer also measures loop currents up to 100mA, provides outputs of the internally generated reversal and pseudorandom standards, and indicates marking status of the line. It accommodates the same interface signal levels and data speeds as the PG-303A pattern generator.

64.-69. RESERVED.

CHAPTER 3. STANDARDS AND TOLERANCES

70. GENERAL.

a. Key Parameters. This chapter prescribes the standards and tolerances for general teletypewriter equipment, as defined and described in Order 6000.15A, General Maintenance Handbook for Airway Facilities. All key performance parameters and/or key inspection elements are clearly identified by an arrow (→) placed to the left of the applicable item.

b. Long Lines Signal Distortion. The tariff under which the teletypewriter or teleprinter service is

provided does not establish a maximum distortion figure for the received signal. The distortion on telegraph loops will vary from loop to loop depending upon several parameters. Line length, equipment, circuit speed, and types of transmission media are some of the factors determining the amount of distortion that may be present at the receiving equipment. It is to be remembered that the serving companies, under the tariff, guarantee only good copy. However, there are mutually agreed upon distortion limits above which the local testboards are to be contacted. These limits will vary according to facility and serving company.

STANDARDS AND TOLERANCES, GENERAL DATA-HANDLING EQUIPMENT

Parameter	Reference Paragraph	Standard	Tolerance/Limit	
			Initial	Operating
71. RECEIVING EQUIPMENT.				
→ a. Marking and spacing bias..... tolerance.	103	≥40%	≥40%	≥40%
→ b. Marking and spacing average..... end distortion.	103	≥40%	≥40%	≥40%
→ c. Marking and spacing average..... internal bias distortion.	103	≤5%	≤5%	≤5%
72. TRANSMITTING EQUIPMENT.				
→ a. Transmitter distributor average..... distortion.	104	≤4%	≤4%	≤4%
b. Reserved.				
73. ANCILLARY AND MISCELLANEOUS EQUIPMENT.				
a. TSU-10 line switching unit.				
* (1) PS-3 and RA-5 power..... supply voltage.	112	125V dc	125V dc	±1.0V *

STANDARDS AND TOLERANCES, GENERAL DATA-HANDLING EQUIPMENT (Continued)

<i>Parameter</i>	<i>Reference Paragraph</i>	<i>Standard</i>	<i>Tolerance/Limit</i>	
			<i>Initial</i>	<i>Operating</i>
* (2) Line repeater (LR) threshold.		50 percent commission value	Same as standard	Same as standard *
→ b. Relay control group busy line (BL) relay release time.	111	400ms	±25ms	±100ms

74.-79. RESERVED.

CHAPTER 4. PERIODIC MAINTENANCE

80. GENERAL.

a. This chapter establishes all the maintenance activities which are required for terminal teletypewriter equipment on a periodic, recurring basis, and the schedules for their accomplishment. The chapter is divided into two sections. The first section identifies the performance checks (i.e., tests, measurements, and observations) of normal operating controls and functions which are necessary to determine whether operation is within established tolerances/limits. The second section identifies other tasks which are necessary to prevent deterioration and/or ensure reliable operation. Refer to Order 6000.15 for additional general guidance.

b. When using the schedules of this chapter, it is permissible to reduce maintenance at facilities that operate on a schedule of less than 24 hours per day, less than 7 days a week, or where the teletypewriter equipment is normally turned off and used only for test purposes or as backup, for short periods of time, for an electronic selector device. Performance checks or other maintenance tasks may be reduced in proportion to the number of hours of equipment operation but not less than the minimum level as specified in applicable Teletype Corporation Bulletins or Sections covering lubrication of the equipment. In no event shall such minimum scheduled periodic maintenance be reduced below the level of each 1500 hours of operation or each 6 months, whichever occurs first. This provision for reduced periodic maintenance is applicable to certain AID, AMOS, part time weather station, and other remote facilities where a significant saving in man-hours, energy, and travel can be realized without sacrificing reliability and availability. For example, Teletype Corporation Section 573-115-701TC specifies a lubrication interval for the model 28 typing unit as follows:

Hours of operation per day at 100 wpm:	0-8	8-16	16-24
Lubrication interval (5-day week)	39 weeks	28 weeks	13 weeks
Lubrication interval (6-day week)	33 weeks	24 weeks	11 weeks
Lubrication interval (7-day week)	27 weeks	20 weeks	9 weeks

(This example illustrates a method of computing reduced periodic maintenance that can be applied to all other equipment; however, in no event shall a reduction greater than six months be taken.)

c. Exchange and repair (E&R) scheduled in this chapter is on an "as required" basis normally greater than 8 years' service, as determined by the region. See the latest edition of Order 4620.1, Scheduled Overhaul of Ground Facilities Equipment. "Overhaul" consists of removal and disassembly of subunits (main shaft, stunt box, etc.) for cleaning of all metal parts in an approved solvent (nonmetal elements shall not be immersed but shall be wiped clean); inspection of all parts for suitability of reuse; replacement of those parts not deemed reusable (bearings, felts, sprints, and lock-washers shall be replaced only as required); reassembly of unit; complete adjustment of unit; lubrication; final testing and return to normal service status.

Section 1. PERFORMANCE CHECKS

<i>Performance Check</i>	<i>Reference Paragraph</i>	
	<i>Standards & Tolerances</i>	<i>Maintenance Procedures</i>
81. BIMONTHLY (60 DAYS).		
a. Check marking and spacing bias tolerance..... Enter in FAA Form 6170-1.	71a	103
b. Check marking and spacing end distortion..... tolerance. Enter in FAA Form 6170-1.	71b	103
c. Check marking and spacing internal bias..... distortion. Enter in FAA Form 6170-1.	71c	103
* d. Check transmitter-distributor distortion..... Enter in FAA Form 6170-1.	72a	104
82.-89. RESERVED.		

Section 2. OTHER MAINTENANCE TASKS

Subsection 1. M28, M35, AND M37 EQUIPMENT

<i>Other Maintenance Tasks</i>	<i>Reference Paragraph</i>	
	<i>Standards & Tolerances</i>	<i>Maintenance Procedures</i>
90. MONTHLY.		
* a. Typing unit (LP, YP).....	-	110
(1) Clean and adjust type pallets.....	-	
(2) Check function of stunt box	-	
(3) Clean selector magnet pole faces.....	-	*
b. Reperforator-Transmitter (RT).	-	-
Exercise RT sets used for A-BDIS emergency low-speed backup circuits (low speed relay) with a local test loop to ensure proper operation.		

Section 2. OTHER MAINTENANCE TASKS (Continued)
Subsection 1. M28, M35, AND M37 EQUIPMENT (Continued)

<i>Other Maintenance Tasks</i>	<i>Reference Paragraph</i>	
	<i>Standards & Tolerances</i>	<i>Maintenance Procedures</i>
91. BIMONTHLY (60 DAYS).		
* a. Clean, inspect, and lubricate typing unit (LP, YP).	—	110
b. Clean, inspect, and lubricate keyboards (LK, LB, LAK, YK, YB).	—	110
c. Transmitter-Distributors (TD).		
(1) Clean, inspect, and lubricate LBXD TD and bases.	—	110
(2) Clean, inspect, and lubricate LAXD TF and bases (except A-BDIS emergency low-speed backup circuits).	—	110
(3) Clean, inspect, and lubricate LXD TD and bases.	—	110
(4) Clean, inspect, and lubricate LCXD TD and bases.	—	110
(5) Clean, inspect, and lubricate M14 TD.	—	110
d. Perforators and Reperforators.		
(1) Clean, inspect, and lubricate LPE nontyping perforators, LTPE typing perforators and bases.	—	110
(2) Clean, inspect, and lubricate LPR..... typing reperforators and bases.	—	110
(3) Clean, inspect, and lubricate LRPE..... nontyping reperforator and bases.	—	110

*

Section 2. OTHER MAINTENANCE TASKS (Continued)
Subsection 1. M28, M35, AND M37 EQUIPMENT (Continued)

<i>Performance Check</i>	<i>Reference Paragraph</i>	
	<i>Standards & Tolerances</i>	<i>Maintenance Procedures</i>
* (4) Clean, inspect, and lubricate YRPE and YPR units and bases.	-	110
c. Reperforator-Transmitter (RT)..... Subassemblies (except A-BDIS low-speed backup circuits).		
(1) Clean, inspect, and lubricate LRXB..... (base) and LTHS (tape handling stand).	-	110
(2) Clean, inspect, and lubricate RT module subassemblies.	-	110
f. Relay control group, BL relay release..... time adjustment.	73b	111
92. QUARTERLY.		
a. Clean, adjust, and lubricate distortion test set, CA-406.	-	110
b. Clean, inspect, lubricate, and align motor units (LMU, YMU).	-	110
c. Clean and inspect cabinets.	-	-
93. SEMIANNUALLY.		
a. Service and test rectifiers.	-	-
b. Clean, inspect, and lubricate A-BDIS, emergency low-speed backup RT equipment.		110
(1) LAXD.....	-	
(2) LPR.....	-	
(3) LRXB, LTHS.....	-	

*

Section 2. OTHER MAINTENANCE TASKS (Continued)
Subsection 1. M28, M35, AND M37 EQUIPMENT (Continued)

<i>Other Maintenance Tasks</i>	<i>Reference Paragraph</i>	
	<i>Standards & Tolerances</i>	<i>Maintenance Procedures</i>
94. TWO-YEAR INTERVALS.		
* Perform a complete field overhaul of all M28, M35, and M37 and associated equipment.	-	110
95. EIGHT-YEAR INTERVALS		
Exchange and repair (E&R) typing units..... with FAA Depot.	-	-
96-97. RESERVED.		

Subsection 2. ANCILLARY AND MISCELLANEOUS EQUIPMENT

<i>Other Maintenance Tasks</i>	<i>Reference Paragraph</i>	
	<i>Standards & Tolerances</i>	<i>Maintenance Procedures</i>
98. EARLY MODELS AND ANCILLARY EQUIPMENT.		
* a. Monthly.		
(1) Clean, inspect, and lubricate early models in use (M15 and M19)	-	110
(2) Clean and inspect APULS equipment	-	113
b. Quarterly.		
(1) Calibrate TSU-10 power supply voltages,..... and adjust LR threshold.	73a	112
(2) Lubricate stepping switches of APULS equipment.	-	114
c. Annually. Lubricate latching relay in APULS equipment.	-	114
d. As Required. Check and align..... APULS equipment.	-	115
99. RESERVED.		

CHAPTER 5. MAINTENANCE PROCEDURES

100. GENERAL.

This chapter establishes the procedures for accomplishing the various essential maintenance activities which are required for teletypewriter equipment, on either a periodic or incidental basis. The chapter is divided into three sections. The first section describes the procedures to be used in making the performance checks listed in chapter 4, section 1. The second section describes the procedures for doing the tasks listed in chapter 4, section 2. The third section describes the procedures for doing special tasks, usually nonscheduled and not listed in chapter 4. Refer to Order 6000.15 for additional general guidance.

101. TEST EQUIPMENT.

Detailed adjustment of test equipment (control settings, use of switches, etc.) is omitted from the procedures in this chapter. The test equipment manuals contain information sufficient for the operation of such equipment and need not be duplicated. Table 5-1 lists test equipment required in this chapter by generic name and the nomenclatures of preferred and substitute items. For additional test equipment descriptions by authorized facility, refer to the latest edition of Order 6200.4, Test Equipment Management Handbook.

TABLE 5-1. TEST EQUIPMENT LISTING

<i>Generic Name</i>	<i>Preferred Item</i>	<i>Substitute Item</i>
Digital distortion analyzer; distortion test set (dts)	Distortion Analyzer, Communications Technology Model DTS-531P, or	Digital Pattern Analyzer FA-5648 (74.2 baud)
	Data Analyzer, Stelma Telecommunications Model DMS-303A	Telegraph Signal Analyzer Stelma Model TDA-2()
		Data Analyzer DMS-303A
		Digital Pattern Analyzer Digitech Model DT-625
Digital pattern generator; distortion generator	Pattern Generator, Stelma Telecommunications Model PG-303A	Telegraph Signal Analyzer Digitech Model DT-603-2
		Digital Pattern Generator FA-5647 (74.2 baud)
		Word Generator, Digitech Model DT-103-2
		Distortion Generator CA-406
Teletypewriter test bench	Teletypewriter test bench	Transmitter Distributors ED-200 or M14
		M28 or M35 teleprinter (RO, KSR, or ASR)
Printer test set	Relay test set Digitech Model RTP-3	Printer Test Set CA-405A

TECHNICAL PERFORMANCE RECORD										DATA - HANDLING TERMINAL EQUIPMENT (TELETYPEWRITER)																			
FACILITY (ACT, FSS, ARTCC, RCC, CS/T, etc.) <i>FSS</i>					DATES FROM <i>9/3/78</i> TO					SUPERVISOR (Signature) <i>RAM M-5-COL</i>					CHANNEL OR CIRCUIT <i>XYZ</i>														
LOCATION (city, state, airport, other) <i>Marble, Wt</i>					EQUIPMENT TYPE (ASR, KSR, RO, LPR, etc.) <i>ASR M2B</i>					BAUDS <i>742</i>					REMARKS														
DATE	TIME GMT	UNBIASED S10	HIGH RAS	UNBIASED S10	LOW RAS	MID RAS	RANGE SPREAD (Margin)	UPPER RAS	MB	LOWER RAS	SB	OPTIMUM RAS	ORB	BIAS TOL.	BT	UPPER RAS	SE	LOWER RAS	ME	OPTIMUM RAS	ORD	END TOL.	ET	INTERNAL BIAS	TOL.-I	TD DIST.	KBD DIST.	INITIALS	
<i>1978</i>	<i>0930</i>	<i>110</i>	<i>90</i>	<i>0</i>	<i>35</i>	<i>110</i>		<i>82</i>	<i>15</i>	<i>48.5</i>	<i>68.5</i>	<i>88</i>	<i>12</i>	<i>50</i>	<i>79</i>	<i>1.5</i>	<i>3</i>	<i>3</i>	<i>3</i>	<i>3</i>	<i>3</i>	<i>3</i>	<i>3</i>	<i>3</i>	<i>3</i>	<i>3</i>	<i>3</i>	<i>3</i>	<i>3</i>
<i>9/3</i>	<i>1630</i>	<i>91</i>	<i>19</i>	<i>39</i>	<i>78</i>			<i>83</i>	<i>15</i>	<i>49</i>	<i>69</i>	<i>87</i>	<i>12</i>	<i>49.5</i>	<i>72.5</i>	<i>0.5</i>	<i>4</i>	<i>3</i>	<i>3</i>	<i>3</i>	<i>3</i>	<i>3</i>	<i>3</i>	<i>3</i>	<i>3</i>	<i>3</i>	<i>3</i>	<i>3</i>	<i>3</i>

U S GOVERNMENT PRINTING OFFICE 1978 - 676 15H-428/9

Figure 5-1. Sample FAA Form 6170-1

FAA Form 6170-1 (12-78)

Section I. PERFORMANCE CHECK PROCEDURES

102. FAA FORM 6170-1 ENTRIES.

The technical performance record -- data-handling terminal equipment (teletypewriter) shall be prepared in accordance with the performance check schedule of paragraph 81. The form is illustrated in figure 5-1. Sample entries indicate the manner of use. Entries are obtained from the checks and calculations of paragraphs 103 and 104. Order 6000.15 should be consulted for general usage of technical performance records, FAA Forms 6000-X (formerly FAA Form 418-XX). If necessary to record additional data, the temporary record or continuation sheet, FAA Form 6000-8 (not illustrated), may be used for the purpose at the discretion of the local maintenance supervisor or responsible technician.

103. RECEIVING EQUIPMENT DISTORTION TOLERANCE TEST.

a. Object. To determine the bias, end distortion, and internal distortion tolerances of receiving equipment.

b. Discussion. Proper operation of the selector unit of the receiving equipment is essential if the equipment is to be operated under varying line conditions. By maintaining the unit with zero or near zero internal distortion, the tolerance to line distortion will remain high. The following measurements are made to determine how much distortion the teletypewriter equipment will tolerate while still producing page copy.

c. Test Equipment Required.

- (1) Distortion generator.
- (2) Distortion test set.
- (3) Teletypewriter test bench.

d. Conditions. If a CA-406 distortion generator is used, it should be adjusted for 35 percent distortion while transmitting a "quick brown fox" tape. Should a DTS-531P distortion test set or PG-303A pattern generator be used, the "quick brown fox" message can be generated internally with 35 percent distortion.

e. Detailed Procedure.

(1) High Range Arm Setting (RAS) Marking Bias (MB). Place the distortion generator (or test set) on the MARKING BIAS position and find highest RAS of equipment while still producing error-free copy. Note reading.

(2) Low RAS, Spacing Bias (SB). Switch distortion generator to SPACING BIAS position and find lowest RAS while still producing error-free copy. Note reading.

(3) High RAS, Spacing End Distortion (SE). Place the distortion generator switch into spacing end distortion position and find the highest RAS while still producing error-free copy. Note reading.

(4) Low RAS, Marking End Distortion (ME). Switch distortion generator to MARKING END DISTORTION position and find the lowest RAS while still producing error-free copy. Note reading.

(5) Calculate the optimum RAS for end distortion (ORD) by utilizing the formula:

$$\text{ORD} = \frac{\text{SE} + \text{ME}}{2}$$

(6) Calculate the optimum RAS for bias (ORB) utilizing the formula:

$$\text{ORB} = \frac{\text{MB} + \text{SB}}{2}$$

(7) Calculate the bias tolerance (BT) utilizing the formula:

$$\text{BT} = \frac{\text{MB} - \text{SB}}{2} + 35\%$$

(8) Calculate the end distortion tolerance (ET) utilizing the formula:

$$\text{ET} = \frac{\text{SE} - \text{ME}}{2} + 35\%$$

(9) Calculate the internal bias (I) utilizing the formula: $I = \text{ORD} - \text{ORB}$

(a) If the value of ORB is greater than ORD, turn the selector armature spring adjustment nut counterclockwise to further reduce the internal bias.

(b) If the value of ORD is greater than ORB, turn the selector armature spring adjustment nut clockwise to further reduce the internal bias.

104. TRANSMITTING EQUIPMENT DISTORTION TEST.

a. Object. This measurement is made to determine the percentage of distortion on signals transmitted by the transmitter-distributor (TD) equipment.

b. Discussion. Since any distortion induced into the signal line adds to the characteristic distortion of the line, it is necessary that the transmitter equipment's distortion be held to a minimum.

c. Test Equipment Required. Distortion test set or analyzer.

d. Conditions. If a DTS-531P distortion test set is used, it first must be calibrated for 74.2-baud rate. This can be accomplished using the procedure in chapter 5, paragraph 125, of this order.

e. Detailed Procedure.

(1) Patch the TD to be evaluated into the test circuit with the distortion analyzer.

(2) Transmit the test tape on the TD under test.

(3) Observe the percentage of distortion indicated by the distortion analyzer.

105. SERVING COMPANY OR FAA-OWNED LINE TESTS.

Tests on two-point or dedicated lines are governed by maintenance parameters and instructions in the latest edition of Order 6000.22, Maintenance of Two-Point Private Lines. Tests on lines serving multipoint stations are not presently covered by any agency maintenance technical handbook. Data handling loop distortion and performance is discussed in paragraph 70b as to the responsibility of the serving company.

106.-109. RESERVED.

Section 2. OTHER MAINTENANCE TASK PROCEDURES

110. CLEANING, INSPECTION, AND LUBRICATION OF M28, M35, AND M37.

a. Cleaning.

(1) The printer should be cleaned before every lubrication. If cleaning solvent is not used, the printer should at least be wiped clean with lint-free rags. For hard-to-reach spots, use a small stick inside a rag; but be careful that small springs are not dislodged.

(2) Cleaning solvents are sold by numerous companies under various trade names. It is important that a locally approved solvent that is noncorrosive to metals and nylon be used. Although most solvents are flammable, it is possible to obtain noncombustible ones. Contact with the skin should be avoided because some solvents are absorbed directly into the body through unbroken skin or, at the least, can cause moderate irritations. All solvent work should be under a fume hood or in a highly ventilated area. While some solvents do not give off toxic vapors, they may displace room air resulting in suffocation (i.e., Freon). The latest edition of Order 6930.1A, Fire Prevention and Maintenance of Fire Protection Equipment, provides guidance on the handling, storage, and disposal of cleaning materials.

(3) Cleaning solvent may be used alone or with other agents. When used with ammonia, it cleans better. When mixed 10-to-1 with oil, a thin film of oil will remain to provide some lubrication and to prevent rust. After washing with cleaning solvent, the equipment should be completely dry before lubricating. If

compressed air is available, it can be used to aid the drying process; however, care should be taken to insure that no springs are dislodged. Extreme care should be taken to insure that all felt washers and wicks are completely dry before they are relubricated.

b. Inspection. After it has been cleaned, the printer should be inspected. All springs should be in place and properly hooked at each end. Replace any malformed springs and any missing spring wicks. All screws and nuts should be tight. Replace any worn, broken, or bent parts. A worn part will usually have a groove worn in it or a corner worn off. After a thorough inspection has been made, proceed with lubrication of the equipment.

c. Lubrication. The stunt box contains 438 of the 836 lubrication points in the printer. Before lubricating the stunt box, it must be removed from the printer. Use Teletype Corporation oil (KS7470) and grease (KS7471) in all locations indicated by the appropriate Teletype Bulletin or Section (par. 91). Apply only the specified amount of oil. If one drop of oil is indicated, be sure that only one drop is applied. How to apply this one drop of oil is a difficult problem. Most force-feed (pistol-type) oilers will not meter out one drop at a time. The pencil-type, push-to-dispense, one-drop oiler is difficult to use in close quarters and will not operate except with the point down. A very small artist's brush, dipped in oil and wiped on the oiling point, could be used. In any event, do not overlubricate. Excess oil and grease will drop or be thrown away from desired spots and cause faster accumulation of dirt, malfunction of electrical con-

tacts, and deterioration of wiring. It is very important to not get oil between the selector armature and the magnetic pole pieces. After lubrication, a piece of hard surface paper, such as bond, should be pulled back and forth between the energized armature and pole pieces. The lubrication of some points, such as cam surfaces, can best be accomplished by using a small artist's brush to "paint" the oil on. Felt wicks and washers should be saturated with oil, but they should not have oil dripping from them. Lubrication of some points is indicated by G (apply thin film of grease). This means the total surface should be covered with a thin film of grease. One way to apply the grease is to use a small stiff brush, such as an acid brush. Dip the brush in grease and wipe it across the part to be greased. By pressing hard and wiping fast, excess grease is removed by the brush. Another easy way to apply grease is to use a cotton swab stick. The same techniques used on the printer will apply to other equipment, with specific lubrication points to be designated by the appropriate bulletin or section (refer to appendix 4).

111. RELAY ADJUSTMENTS.

a. **Object.** To adjust the relays of the transmitter control group relay panel.

b. **Discussion.**

(1) This paragraph outlines a procedure for maintenance and adjustments of the BL relay and provides instructions on how to correct a deficiency in the relay.

(2) The BL relay used in the transmitter-control group relay panel has presented many problems because the dropout time intermittently exceeds 500 milliseconds. These adjustment procedures and the instructions for trueing the pole face will improve the relay operation.

(3) The general instructions and techniques outlined in this paragraph are applicable to other relays of the group.

c. **Test Equipment Required.**

- (1) Model 14 or ED-200 transmitter-distributor.
- (2) Printer or test bench.
- (3) Miscellaneous relay maintenance tools.

d. **Conditions.**

(1) Relay removed from cabinet and adequately supported for ease of adjustment.

(2) Performance tests to be conducted on dummy circuit using a special test tape.

e. **Detailed Procedures.**

(1) Armature airline adjustment. The clearance between the end of the heelpiece and the armature when the armature is closed against the polepiece, is known as the airline. The following steps outline airline adjustments procedures: (See figure 5-2).

(a) Loosen the clamping screw that holds the armature to the heelpiece.

(b) Place a 0.0015-inch thickness gage in the airline gap so that it extends over the entire width of the heelpiece.

(c) Press the armature firmly against the gage and heelpiece.

(d) Tighten the armature clamp screw.

(e) Remove the gage and check the airline visually while holding the armature closed.

(2) The Armature Residual Disc should contact evenly on the pole face. The armature should NOT contact the pole face. If the armature does, the relay is defective and should be replaced. If a spare relay is not immediately available, the relay may be corrected by the following procedure:

(a) Loosen and remove the clamp screw that holds the armature to the heelpiece.

(b) Remove the armature.

(c) With a file or Carborundum stone, true the pole face at the point where the armature contacts the pole face.

CAUTION: Do not overfile the pole face or the relay will be damaged.

(d) Replace armature and clamp screw. Tighten clamp screw friction-tight and repeat 111e(1)(a) through (e).

(3) Contact Assembly Adjustment. Before adjustments are made, all break-and-make springs should be

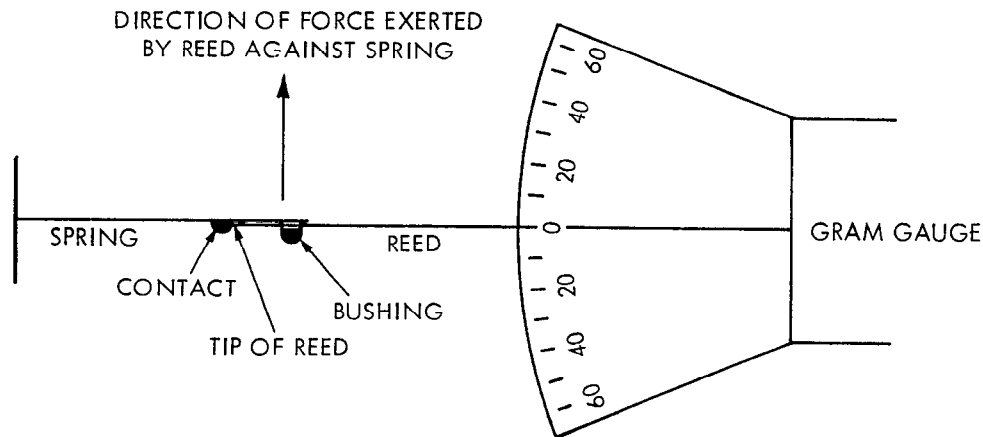
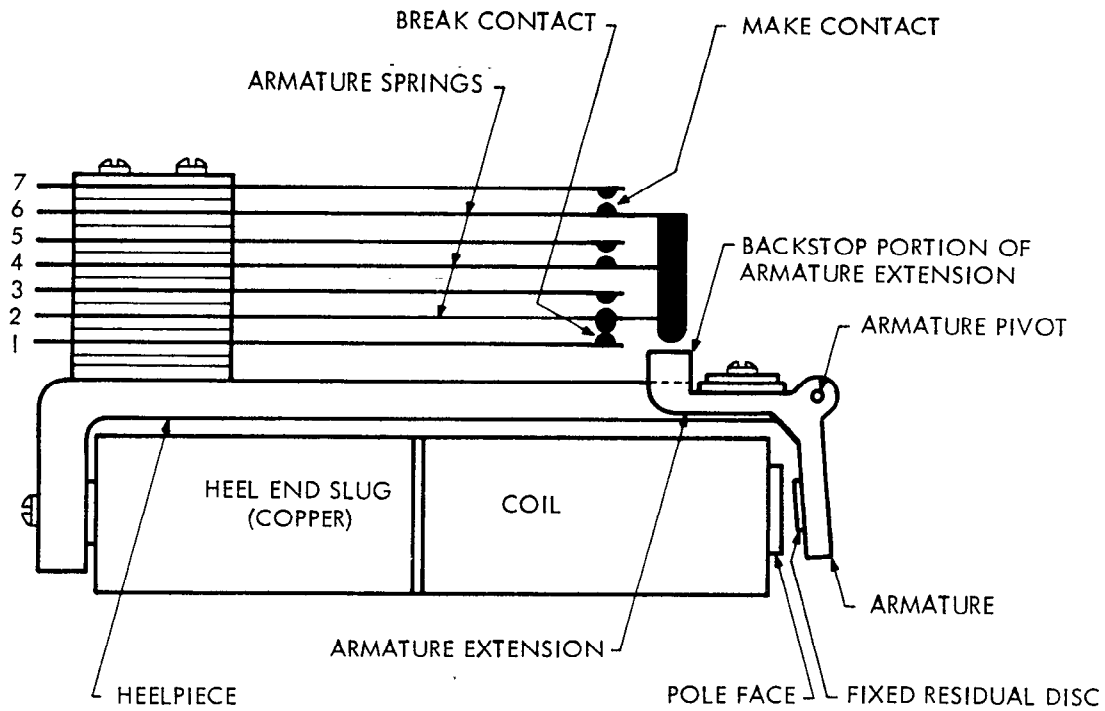

Figure 5-2. BL Relay Adjustment

set parallel to the heelpiece by bending them adjacent to the pileup. Reference figures 5-2 and 5-3.

(a) The contact pressure should be measured as indicated in figure 5-2 and should be 30 ± 1 gram.

(b) The contact pressure should be noted at the instant the break contacts open and the make contacts close.

(c) If contacts are only slightly out of adjustment, they should be corrected by using a spring bender to put a small bend in the spring adjacent to the pileup. Avoid kinking or twisting the springs.

(d) Use only the proper relay tools. Damage may result from the use of any other tools for relay adjustments.

ALL RELAYS (VIEWED FROM THE REAR)
 NOMINAL VOLTAGE 48 VOLTS D C -60 mA CURRENT
 CONTACTS: 18 GAUGE
 RATING: 135 WATTS (NONINDUCTIVE)
 3 AMPERES

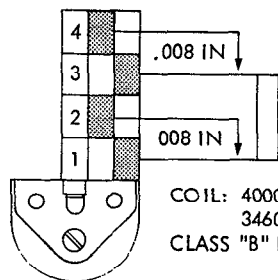

COIL: 4000Ω - D C RESISTANCE
 34600 TURNS - NO. 38 E.C. WIRE
 CLASS "B" RELAY - TYPE 57 AL
 STROKE - .014 IN
 RESIDUAL DISC - .003 IN
 TEST FOR: (CURRENT VALUES IN AMPERES)
 OPEN .00301 (READJUST) .00324 (TEST)
 NOT OPEN .00254 (READJUST) .00231 (TEST)

160325 - "RS 1" RELAY

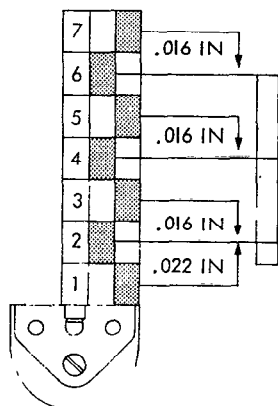

179954 "OL" / "BL" RELAY

CLASS "B" RELAY TYPE 57AS
 STROKE - .036 IN
 TEST FOR: (CURRENT VALUES IN AMPERES)
 OPEN .0052 (READJUST) .0052 (TEST)
 NOT OPEN .0049 (READJUST) .0048 (TEST)

160326 - "ST" RELAY

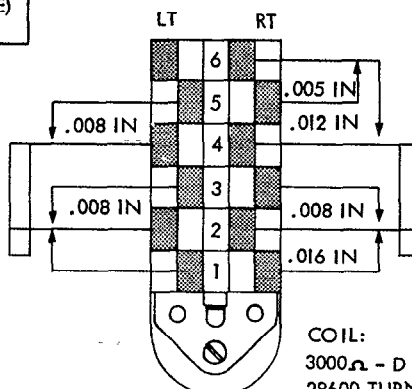

COIL:
 3000Ω - D C RESISTANCE
 28600 TURNS - NO. 38 E.C. WIRE
 STROKE - .026 IN
 RESIDUAL DISC - .003 IN
 TEST FOR: (CURRENT VALUES IN AMPERES)
 OPEN .00682 (READJUST) .00435 (TEST)
 NOT OPEN .00577 (READJUST) .00525 (TEST)

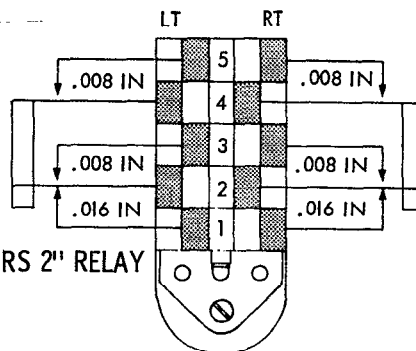

160964 - "RS 2" RELAY

COIL: 3300Ω - D C RESISTANCE
 28000 TURNS - NO. 38 E.C. WIRE
 RESIDUAL (FIXED): .003" HEEL END SLUG
 CLASS "B" RELAY TYPE 57
 STROKE - .026 IN
 RESIDUAL DISC - .003 IN
 TEST FOR: (CURRENT VALUES IN AMPERES)
 OPEN .00682 (READJUST) .00435 (TEST)
 NOT OPEN .00577 (READJUST) .00525 (TEST)

Figure 5-3. Relay Group Adjustment

(4) Spring Tension. Adjust the tension of all armature springs, starting with the one nearest to the heelpiece.

(a) Place the slot of the spring bender over the armature spring near the pileup.

(b) Tilt the spring bender slightly toward the armature and draw it down the spring toward the contact end. This should produce a smooth curve in the spring with the concave side toward the armature.

(c) Again place the slot over the spring, and tilting the spring bender away from the armature,

draw it toward the contacts. The spring will be straightened and tensioned toward the armature extension.

(d) Measure the spring tension and repeat the above procedure if the tensions are less than 30 ± 1 gram. Reverse the procedure above by tilting the bender in the opposite direction if the tensions are greater than 20 ± 1 gram.

(5) Armature Stroke Adjustment.

(a) Insert a 0.020-inch and a 0.024-inch feeler gage (total 0.044-inch) between the armature and the pole face, and operate the relay manually.

(b) Bend the armature extension with an armature bender so that the backstop portion of the extension rests against the heelpiece.

(6) Contact Gaging. The following gaging tests are subject to the requirement for a total contact spring pressure of 60 ± 2 grams:

(a) Insert a 0.024-inch feeler gage between the armature fixed residual disc and the pole face.

(b) Operate the relay manually. The break contacts should just open.

(c) Adjust by bending the first or back spring near the pileup.

(d) The break contacts should not open when the 0.024-inch gage is replaced by a 0.025-inch gage.

(e) Insert a 0.016-inch feeler gage between the armature fixed residual disc and the pole face.

(f) Operate the relay manually. The make contacts should just close. If not, adjust by bending the make or front spring near the pileup.

(g) The make contacts should not close when the 0.016-inch gage is replaced by a 0.017-inch gage.

(7) Operational Evaluation.

(a) After completing the above adjustments, the operation of the relay should be checked under normal operation.

(b) Connect the relay group with its associated printer and a transmitter distributor to the dummy circuit. The ED-200 or model 14 may be used to check the timing.

(c) When using the ED-200, the distortion switch should be set for zero distortion. Install a clip lead on the underside of the distributor between the STOP and START segments of the test TD.

(d) Perforate a continuous tape with enough blank characters between each group for separation. It should be made up as follows:

1 Alternately punch 1 blank and 1 letter character 10 times.

2 Alternately punch 1 blank and 2 letter characters 10 times.

3 Alternately punch 1 blank and 3 letter characters 10 times.

4 Alternately punch 1 blank and 4 letter characters 10 times.

5 Alternately punch 1 blank and 5 letter characters 10 times.

(e) Switch the printer with the relay group to be tested into the dummy circuit along with the testing TD. Start the test tape transmission and observe the busy line indicator on the printer cabinet for an idle line or busy line condition. When the busy line light is extinguished during the test tape transmission, the number of letters that were transmitted at that time will indicate the release time of the BL relay. Refer to step 111(f) for converting the letter characters transmitted into milliseconds elapsed time.

(f) At 100wpm (600rpm) each cycle of the TD distributor will represent approximately 100ms. Strapping together the STOP and START segments and sending letter-blank impulse combinations produces the following usable mark time intervals for checking the BL relay:

BL 1 LTR	=	132.5ms
BL 2 LTRS	=	232.5ms
BL 3 LTRS	=	332.5ms
BL 4 LTRS	=	432.4ms
BL 5 LTRS	=	532.5ms

*

*

*** 112. CALIBRATION OF TELECOM SWITCHING UNIT, MODEL TSU-10.**

NOTE: All external equipment must be removed from the test loop when current limiting adjustment is made.

a. Object. This procedure provides a method to calibrate the TELECOM Switching Unit, Model TSU-10.

b. Discussion. If during normal operation the loop current levels or control voltage falls below the normal levels, calibration should be performed. Calibration of the TSU-10 is limited to power supply and repeater input threshold adjustment.

c. Test Equipment Required. Distortion analyzer/generator/multimeter, Digitech Model 2056 or equivalent.

d. Conditions. The power supplies (PS-3 and RA-5) are mounted on slides and can be extended from the equipment cabinet for calibration.

e. Detailed Procedure.

(1) PS-3 Power Supply Adjustment.

(a) Loosen the two front-panel securing screws, and gently slide PS-3 forward to expose the 120V supply. Refer to figure 5-3A.

(b) Set the Digitech Model 2056 or equivalent to measure dc volts on the 300V scale.

(c) Connect the Digitech Model 2056 or equivalent - and + leads to the 120V supply test points labeled V- and V+ respectively.

(d) Using an offset screwdriver, adjust potentiometer R14 until the Digitech Model 2056 or equivalent reads 125V dc.

(e) Set the TP-3 controls as follows:

- LOOP ADJ CIRCUIT 6
full counterclockwise
- LINE TEST 100 MA
- CIRCUIT SELECT 6

(f) Using an offset screwdriver, adjust potentiometer R9 until the TP-3 meter reads 80mA.

(g) Disconnect the Digitech Model 2056 or equivalent, and secure the PS-3. Restore TP-3 to normal operation.

(2) RA-5 Power Supply Adjustment.

(a) Loosen the two front-panel securing screws, and gently slide the RA-5 forward to expose the power supply assemblies. See figure 5-3B.

(b) Set the Digitech 2056 or equivalent to measure dc volts on the 300V scale.

(c) Connect the Digitech 2056 or equivalent — and + leads to the negative side of C7 and the anode of CR1, respectively.

(d) Adjust the power supply potentiometer R3 until the Digitech 2056 or equivalent reads 125 volts.

(e) Repeat the procedure for the second power supply.

(f) Disconnect the Digitech 2056 or equivalent, and restore the TSU-10 to normal operation.

(3) Line Repeater, LR-1, Input Threshold Adjustment.

(a) Refer to figure 5-3B.

(b) Loosen the two front-panel securing screws, and gently slide the RA-5 forward exposing the five LR-1 assemblies.

(c) Since each LR-1 is calibrated in the same manner and the order of calibration is not important, select one and set its TELCO input to steady mark.

(d) Connect a patch cord from the appropriate RA-5 LINE TEST jack (corresponds with the LR-1 being calibrated) to the TP-3 EXT METER jack, and note the normal input current level.

(e) Reduce the LR-1 input current to half its normal value, e.g. 10mA for 20mA circuits or 30mA for 60mA circuits.

*

*

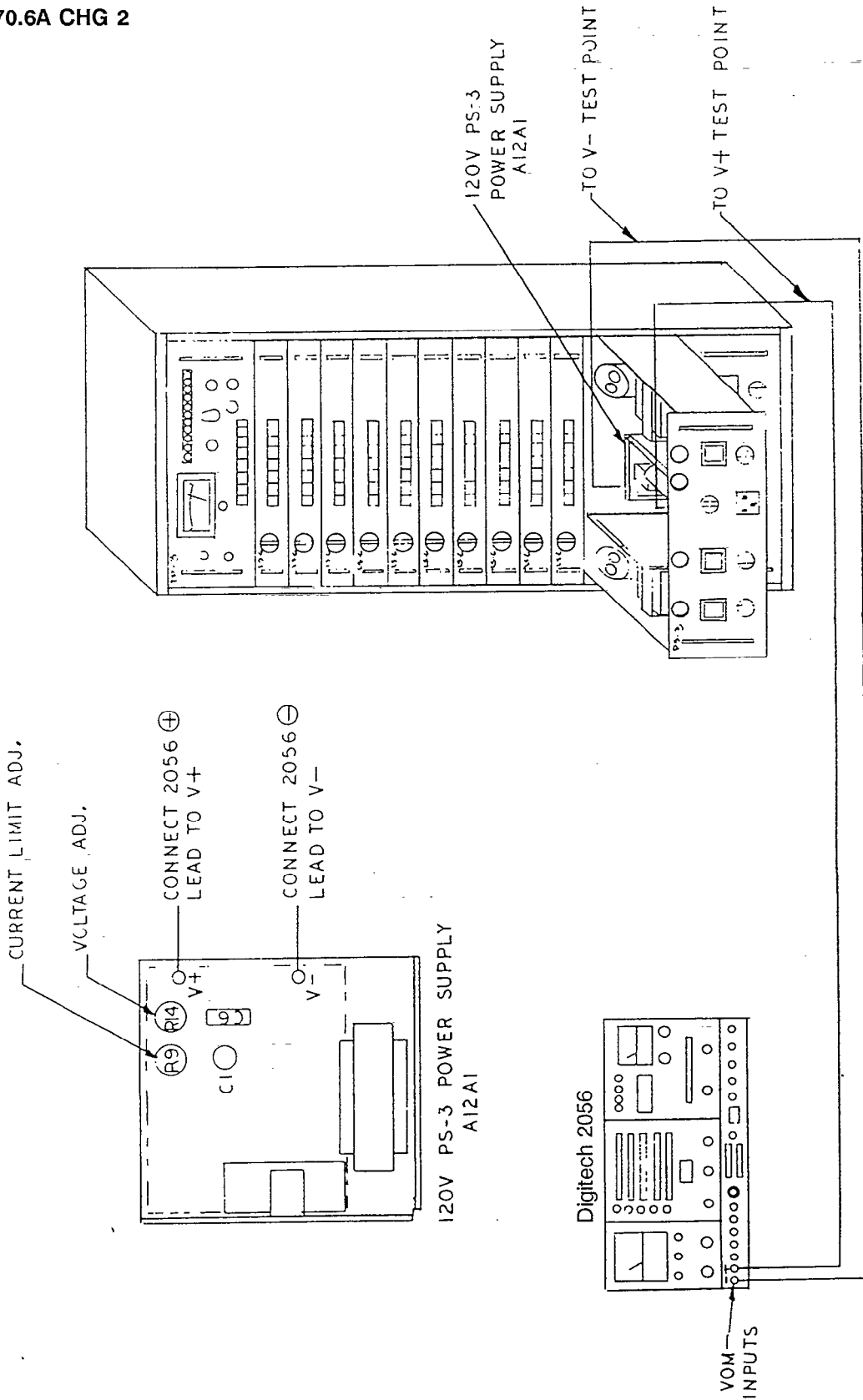

Figure 5-3A. Calibration Adjustment and Test Point Location PS-3

*

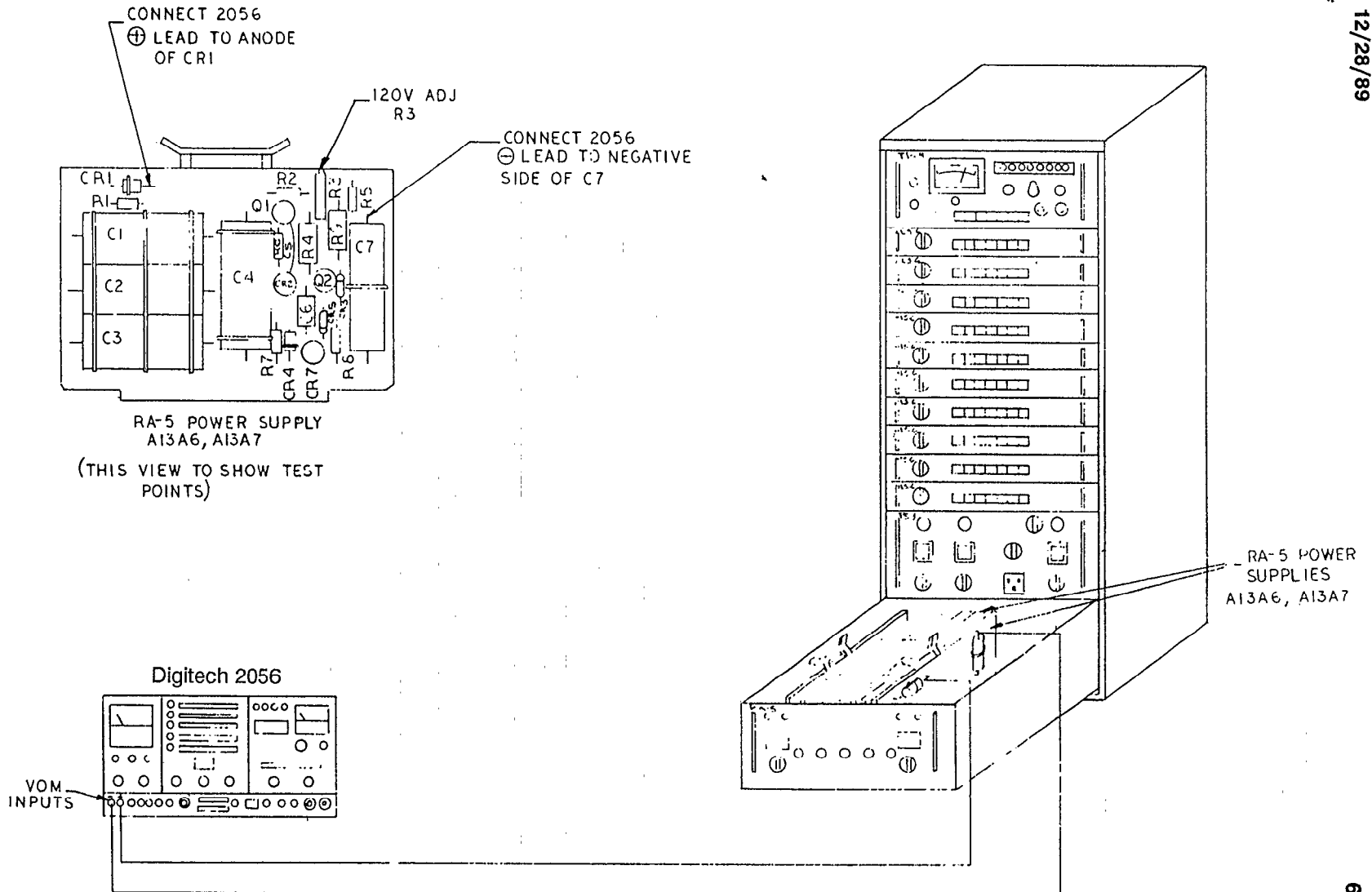

Figure 5-3B. Calibration Adjustment and Test Point Location, RA-5

*

* (f) Remove the patch cord from both the TP-3 and RA-5.

(g) Depress the CIRCUIT SELECT push-button that corresponds with the LR-1 under test, and set the TP-3 LINE TEST switch to 100mA.

(h) Adjust the LR-1 input threshold potentiometer R7 counterclockwise until the TP-3 meter reads 0mA. Now slowly adjust R7 in a clockwise direction until the meter just reads maximum current (steady mark).

(i) Using the TP-3 meter as outlined in step (d), restore the LR-1 input current level to its normal value.

(j) Remove the patchcord between RA-5 and TP-3, and set the TP-3 LINE TEST switch to 100mA + RES.

(k) Using the TP-3 LINE CURRENT control, adjust circuit current level for half its normal value (10mA for 20mA circuits, 30mA for 60mA circuits).

(l) Reconnect the patchcord between the TP-3 EXT METER jack and the RA-5 LINE TEST jack for the LR-1 being calibrated.

(m) Adjust the LR-1 potentiometer R6 counterclockwise until the TP-3 meter reads 0mA. Now slowly adjust R6 in a clockwise direction until the TP-3 meter reads maximum current (steady mark).

(n) The TELCO and TSU-10 input thresholds are now set for the selected LR-1. Repeat the procedure for each LR-1 in need of calibration.

(o) Secure the RA-5 to the equipment rack, and restore the TSU-10 to normal operation.

113. INSPECTION AND CLEANING OF APULS EQUIPMENT.

NOTE: Turn off all power to the unit before performing the following operations. Do not disturb any screwdriver adjustments.

a. Cleaning. Clean front, rear, and sides of chassis. Check finish of front panel and retouch scratches or bare spots.

b. Inspection. Inspect cables and wires for breaks, cuts, fraying or other signs of wear. Inspect mechanical assembly and slides for loose screws, bolts, etc. Inspect resistors and other components for discoloration due to over-heating. Check for corrosion, dirt, and loose contacts at terminal board, switches, and contact points. Inspect filter capacitors for leakage of electrolyte or bulging.

114. LUBRICATION OF STEPPING SWITCHES AND LATCHING RELAYS IN APULS EQUIPMENT.

a. Object. This procedure provides a method for lubricating the stepping switches and latching relays in the APULS equipment.

b. Discussion. Both types (CA-5032 and FA-5032A) of APULS equipment have stepping switches and latching relays. Applicable portions of this procedure will be used, depending on which equipments are available.

c. Test Equipment Required.

- (1) Artist's brush.
- (2) Clean, lint-free rags.

d. Conditions. In this procedure the term "dip" indicates the amount of lubricant to be applied to various points. A dip of lubricant is defined as the amount retained on the brush after it is immersed one-half bristle length in the lubricant and then drawn across the edge of the container to remove the excess. In no case should a droplet form. A light dip is the same as a dip except that the brush is immersed one-fourth its bristle length.

e. Detailed Procedure.

NOTE: During this procedure the type of lubricant will be specified by the use of the letters A, B, or C. These are defined in table 5-2.

(1) Lubrication Procedure for K601 or K602 in CA-5032. See Figure 5-3C.

(a) Set wipers on the last contact, and remove the wiper assembly bearing pin. Apply two dips of *

* lubricant A to each bearing surface. Replace the bearing pin.

(b) Apply two dips of lubricant A to each side of a strip of bond paper, and pass the paper between each pair of wipers on the first two levels of the wiper assembly.

(c) Repeat the procedures in step (b) for the remaining levels of the wiper assembly.

(d) Rotate the wiper assembly to lubricate the bank contacts.

(e) Apply the two dips of lubricant A to a strip of bond paper and pass between:

1 the driving spring and associated armature bushing.

2 the interrupter spring and armature bushing.

(f) Lubricate the brush springs on the first two levels of the wiper assembly by applying a dip of lubricant A to each side of the wipers at the point where the brush springs touch the wipers. Rotate the wiper assembly to distribute the oil on the brush spring.

(g) Using the procedure in step (f), lubricate the brush springs on the remaining levels.

(h) Apply one dip of lubricant B to each armature bearing washer.

(i) Apply one dip of lubricant B to each side of the pawl bearing.

(j) Apply two dips of lubricant C to the ratchet teeth while rotating the wiper assembly to distribute the lubricant.

(2) Lubrication Procedure for K901 (CA-5032 and FA-5032A). See Figure 5-3D.

(a) Apply one dip of lubricant A to the wiper assembly bearing under the pointer.

(b) Apply one dip of lubricant A to the wiper assembly bearing between the ratchet and the main frame.

(c) Apply one dip of lubricant A to each side of a strip of bond paper. Pass the strip between each pair of wiper tips in each of the four levels of the wiper assembly. Rotate the wiper assembly through several complete revolutions to lubricate the bank contacts.

Table 5-2. LIST OF LUBRICANTS

<i>Text Designation</i>	<i>Lubricant Type for Ambient Operating Temp. Range From 0 °C to +50 °C</i>	<i>Lubricant Type for Ambient Operating Temp. Range From -10 °C to +50 °C</i>
A	Nye's clock oil 55022 or equivalent	Dow Corning DC-200 Fluid, viscosity 20, or equivalent
B	Light, colorless mineral oil	Dow Corning DC-33 grease, medium consistency, thinned slightly with Dow Corning DC-200 fluid, Viscosity 20, or equivalent.
C	1:1 (by volume) mixture of Nye's clock oil 55022 and motor-mica or equivalent (stirred to consistency of smooth paste).	2:1 mixture (by volume) of motor-mica and Dow Corning DC-33 grease, medium consistency, thinned slightly with Dow Corning DC-200 fluid, viscosity 20, or equivalent (stirred to consistency of smooth paste).

*

*

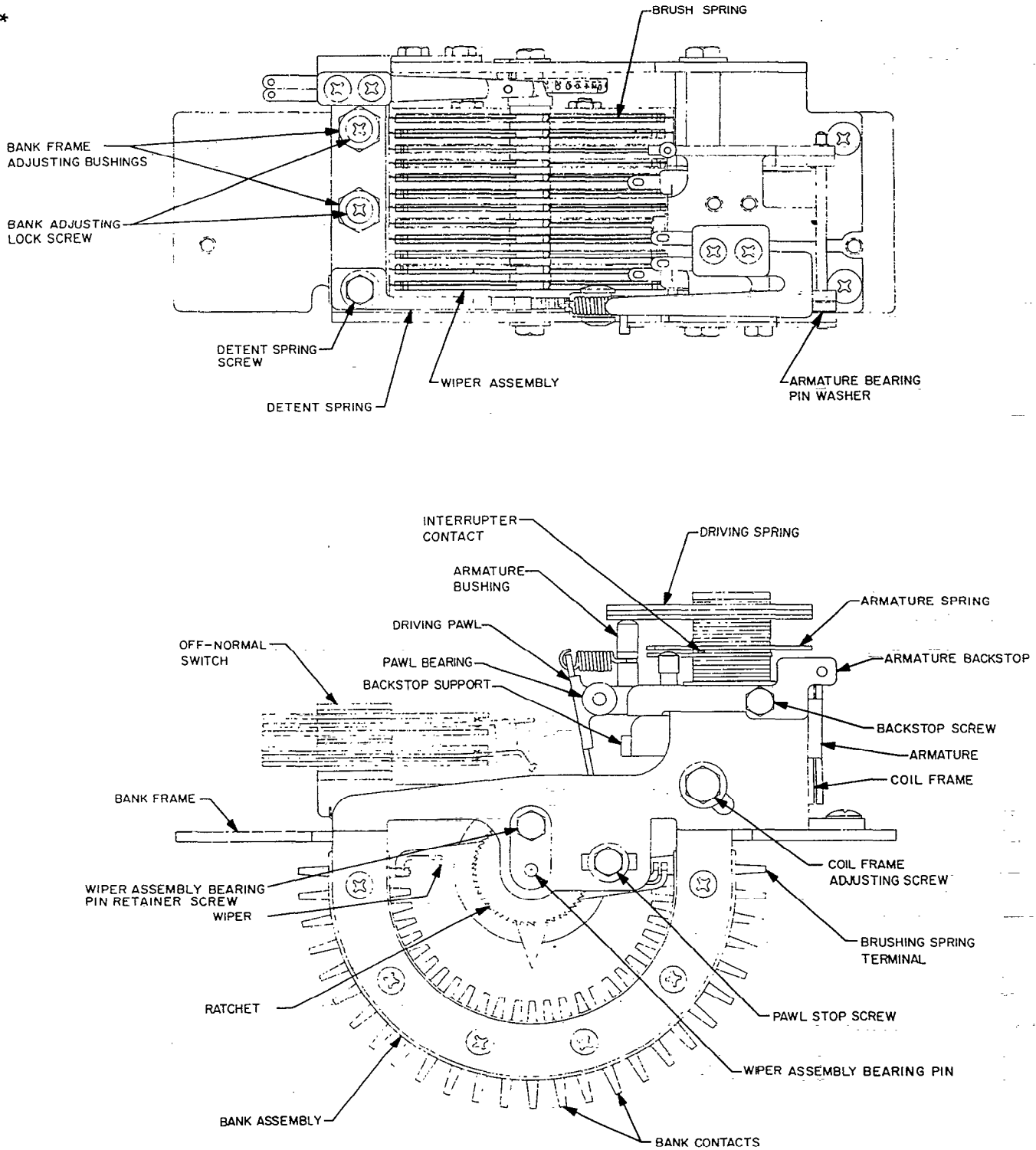

Figure 5-3C. Stepping Switches K601 and K602, Principal Parts

*

* (d) Lubricate the brush springs, using one dip of lubricant A for all four levels of the wiper assembly. Apply lubricant to the inner surface of wipers where the brush springs ride. Rotate wipers several times to distribute the lubricant.

(e) Apply one dip of lubricant A to each side of a strip of bond paper. Pass the strip between each armature arm bushing and the spring it deflects.

(f) Divide one light dip of lubricant A among the lobes of the off-normal cam, applying the lubricant to the lifting surfaces only.

(g) Apply one dip of lubricant B to the two sides of the armature bearing, working lubricant into bearing.

(h) Apply one dip of lubricant B to the pawl bearing, working the lubricant in between the bearing, armature arm, and pawl.

(i) Apply the residue of lubricant B remaining on the brush after step (h) into each pawl spring lock at the eyelet.

(j) Apply two dips of lubricant C evenly over ratchet teeth while rotating wiper assembly.

(3) Lubrication of Latching Relays (CA-5032 and FA-5032A). Apply a light coating of silicon grease (Dow Corning compound 4 or equivalent) to the surface where latch arms bear on each other.

115. ADJUSTMENT PROCEDURES FOR APULS EQUIPMENT.

a. Object. This procedure provide a method for alignment of APULS equipment (CA-5032 and FA-5032A).

b. Discussion. These alignment procedures are intended for use after repairs have been made or faulty operations indicates that readjustment is necessary.

c. Test Equipment Required.

(1) Frequency counter, Hewlett Packard Model 521B or 521C or equivalent

(2) Oscilloscope, Tektronix Model 531 or 535 or equivalent

(3) Distortion analyzer, Stelma Model TDA-2 or equivalent

(4) Multimeter, Simpson 260 or equivalent

(5) Relay test set, Signal Instrument NO. 4501 or equivalent

d. Conditions. The adjustments outlined in this procedure are both electrical and mechanical in nature. Each subparagraph identifies the equipment (CA-5032 or FA-5032A) to which it applies. The controls are identified for both types of equipment in the following manner.

Example. R242 (200A1R39); in the CA-5032 equipment this is R242, in the FA-5032A it is 200A1R39. References for the FA-5032A will be in parentheses. If the procedure is applicable to both equipments, and only one reference is shown, then it is the same for both types of equipment.

e. Detailed Procedure.

(1) Gate Bias Adjustment (CA-5032). R205 is adjusted for even-amplitude sine waves in each burst (same amplitude from the first to the last waveform in the burst, ± 20 percent). To adjust R205:

(a) Connect the oscilloscope to J201.

(b) Adjust R205 for the correct waveform at J201. Adjust for even amplitude of all sine waves in the burst.

(2) Square Bias Adjustment (CA-5032). R212 is adjusted for the most symmetrical output from squarer Q203-Q204. To adjust R212:

(a) Ground the collector of timer gate Q212 to make the oscillator in the transmitter distributor free running.

(b) Connect the oscilloscope to J202.

(c) Set the oscilloscope horizontal frequency to twice the oscillator frequency, and adjust the scope *

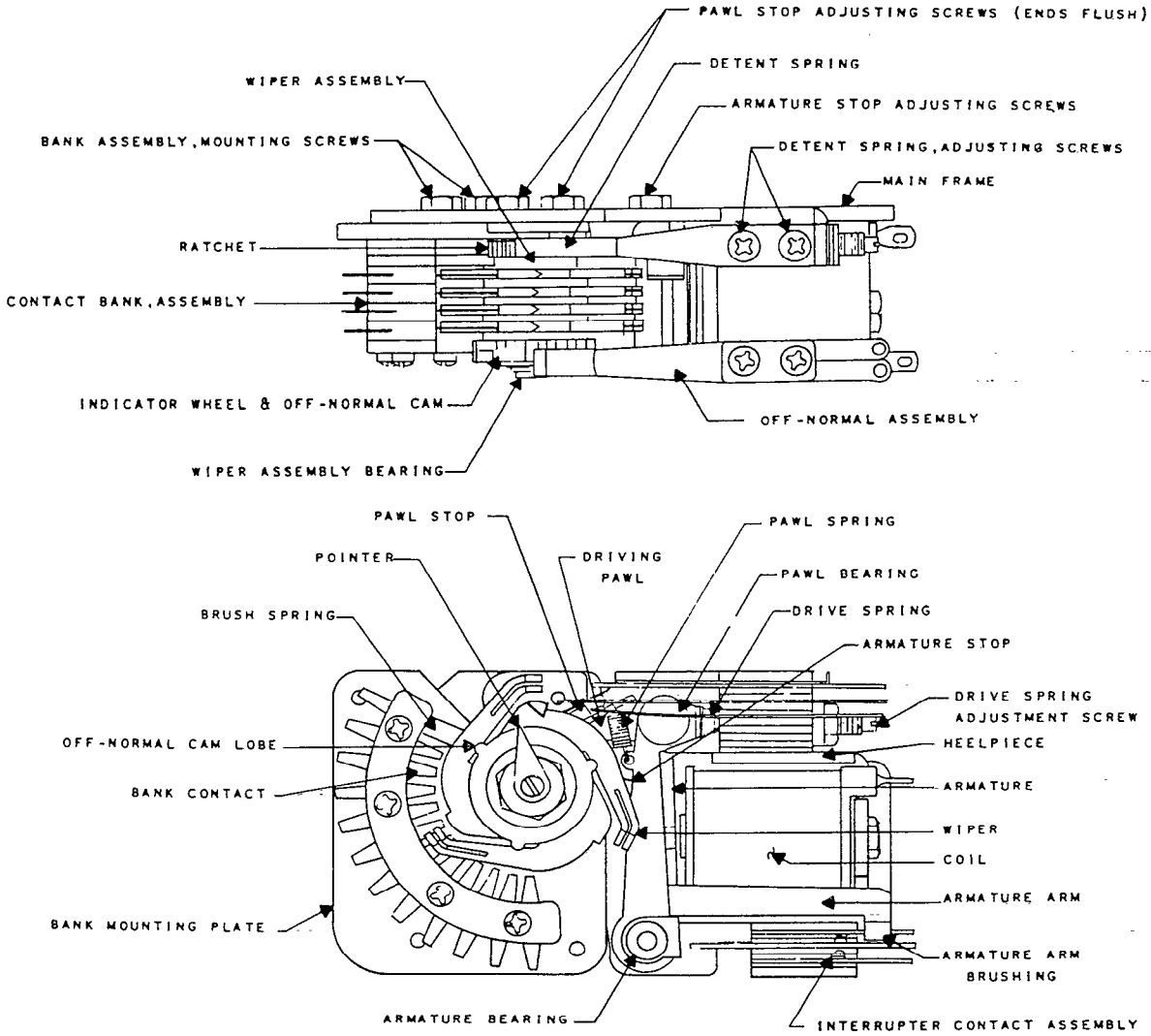

Figure 5-3D. Stepping Switch K901, Principal Parts

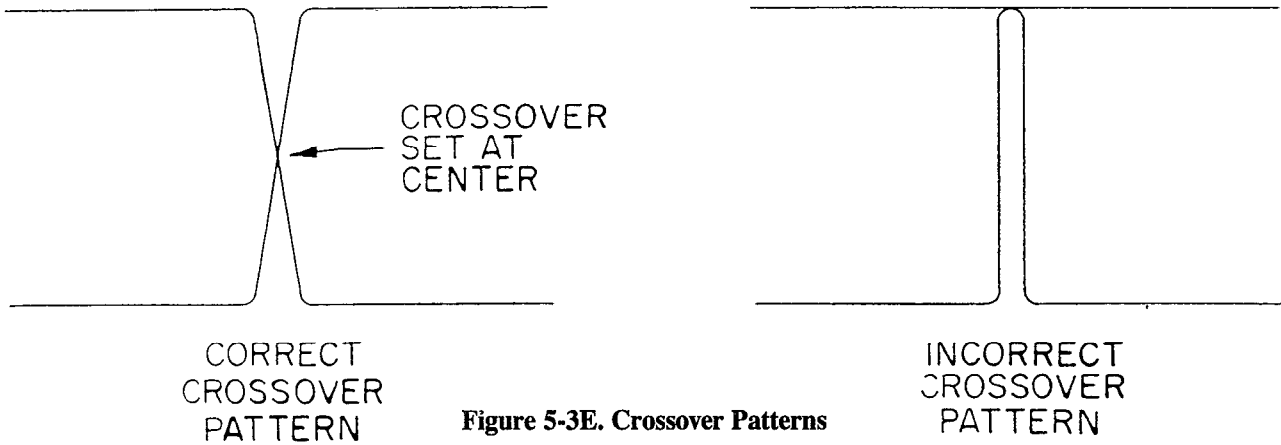

Figure 5-3E. Crossover Patterns

* controls to obtain a crossover pattern similar to the one in figure 5-3E.

(d) Adjust R212 to obtain the best crossover pattern.

(e) Remove the ground from the Q212 collector.

(3) Frequency Adjustment (FA-5032A). 200A1R5 is adjusted to allow the APULS to transmit at the proper baud for the selected output speed (75, 100, or 125 wpm). To adjust 200A1R5:

(a) Connect a jumper wire between ground and test points 200A1TP1 and 200A1TP4 (on distributor); this allows free running operation of oscillator AS-1.

(b) Connect the frequency counter test point 200A1TP3.

(c) Adjust 200A1R5 for the following frequency, $\pm 1/10$ cycle (depending upon the desired output speed in wpm): 55.65 hertz for 75 wpm; 74.2 hertz for 100 wpm; 92.75 hertz for 125 wpm.

(d) Remove the jumper connected in step (a).

(4) Stop-mark Length Adjustment (CA-5032 and FA-5032A). R242 (200A1R39) is adjusted to provide stop-marks having the correct width (1.42 baud) in the generated character for the desired output speed. The frequency adjustment must be performed prior to the stop-mark length. To adjust R242 (200A1R39):

(a) Connect the equipment in a test loop as shown in figure 5-3F.

(b) Connect the oscilloscope to test point J204 (200A1TP5) on the distributor.

(c) Ground the collector of transistor Q212 (200A1Q1), to make the distributor free running.

(d) Using internal sync, synchronize the oscilloscope sweep on the leading (negative transition) edge of the unsymmetrical square wave visible at J204 (200A1TP5). The wider positive alternation represents the start-space and five intelligence bits; the narrow or negative alternation, the stop-mark.

(e) Calibrate the oscilloscope so that 1 cm of sweep is equal to 5ms.

(f) Adjust R242 (200A1R39) until the stop-mark is equal to 1.42 baud. (For 100 wpm the stop-mark should be at 19.1ms wide, 25ms for 75 wpm, 13.3ms for 125 wpm.)

(g) Remove ground from Q212 (200A1Q1) collector.

(5) Relay Bias Adjustment. R209 (200A1R118) is adjusted to obtain minimum distortion in the output of polar keying relay K101. To adjust R209 (200A1R118):

(a) Connect the equipment in the test loop as shown in figure 5-3F, with the APULS terminals connected in series with the distortion analyzer, teletypewriter, and loop voltage supply.

(b) With the power off, adjust the loop current for 60mA.

(c) Turn all equipment power on, and allow units to warm up for 15 minutes.

(d) On FA-5032A, adjust 200A1R118 for minimum distortion as indicated on the distortion analyzer. Distortion should be 3 percent or less.

(e) On CA-5032, adjust R239 for minimum distortion as indicated on the distortion analyzer. Distortion should be 3 percent or less.

(6) Mutilated-mark Bias Adjustment (CA-5032 and FA-5032A). R123 is adjusted to provide a 7ms delay in stopping transmission when a marking bit generated by the unit is not detected in the loop circuit (that is, when marking output is mutilated by an open or busy line). R123 controls the time required for mutilated-mark relay K110 contacts to close. To adjust R123, APULS is placed on steady mark, the letters-shift character (a start-space followed by six marks) is applied to the line continuously, and R123 is varied until an oscilloscope presentation indicates that the relay contacts close 7ms after the leading of the space bit in the applied signal. To adjust R123:

(a) Connect equipment in a test loop setup as shown in figure 5-3F, using a teletypewriter, loop *

*

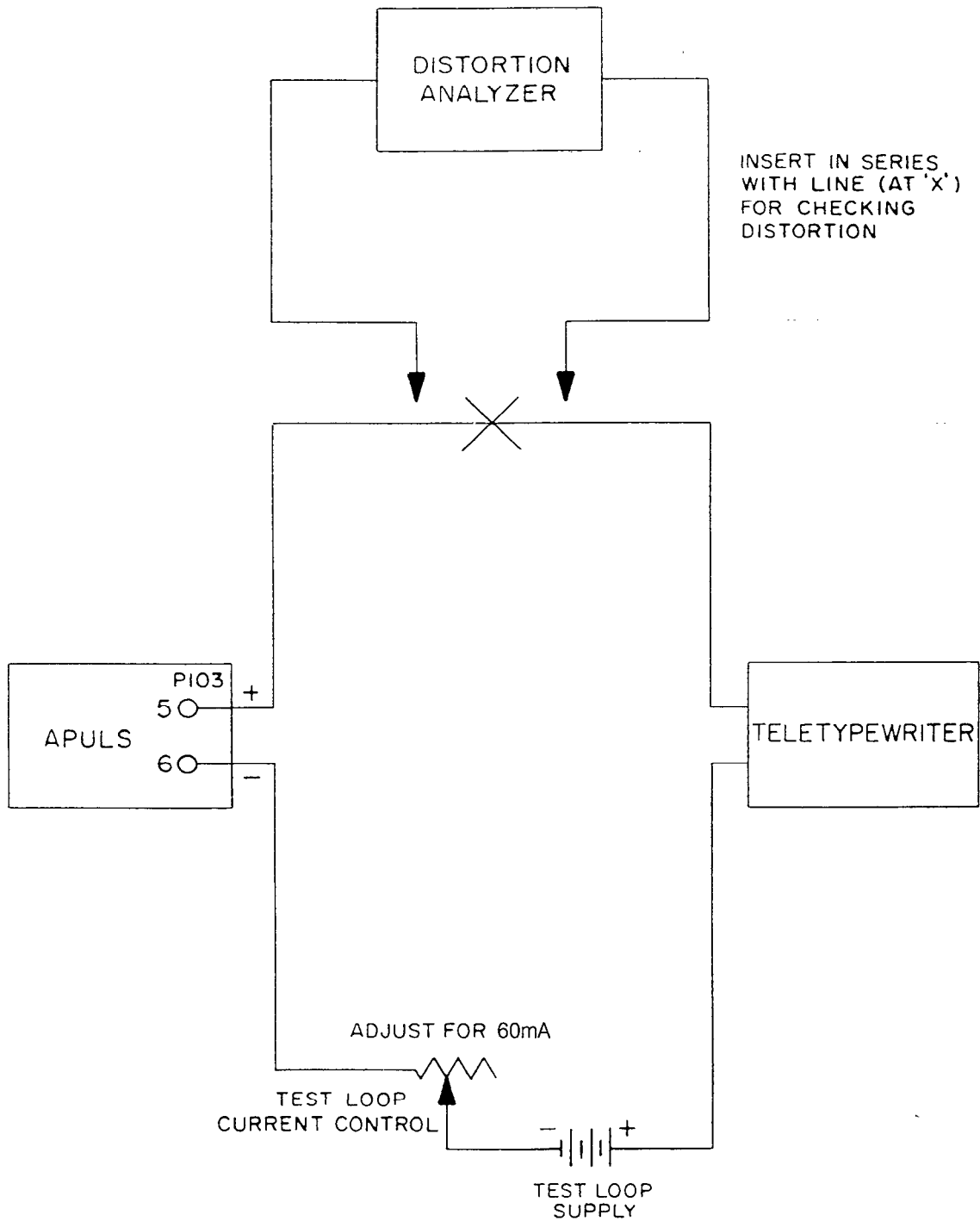

Figure 5-3F. Test Loop Setup

*

* voltage supply, and loop-current adjust control.

(b) With APULS power off, adjust the loop current for 60mA.

(c) Apply steady mark to K110 by making transistor Q203 (200A1Q27) (on the distributor) conduct continuously.

(d) Turn the power on, and depress the START switch.

(e) Connect the vertical input and external sync terminals of the oscilloscope to J103-5, and -6. Set the oscilloscope to external sync.

(f) With letters-shift character on the teletypewriter continuously depressed, synchronize the beginning of the oscilloscope sweep with the leading edge of the start-space of the letters-shift character.

(g) Calibrate the oscilloscope sweep to permit

a convenient measurement of 7ms interval from start of sweep. Note that a start-space is equal to 13.5ms at 100 wpm, to 17.6ms at 75 wpm, and to 9.4ms at 125 wpm.

(h) Without changing the oscilloscope settings, transfer the vertical input leads to contacts 6 and 7 (ground) of relay K110. Leave the external sync connected to J103-5. Check that the letters shift character is still being continually applied.

(i) A spike will be seen on the baseline, representing the closing of K110 contacts, some time after the initiation of the start-space. Adjust R123 so that the spike occurs exactly 7ms after the start of the sweep (leading edge of the start-space).

(j) Remove the connection from Q203 (200A1Q27).

(7) Adjustment of Polar Relays K101 and K110. Adjustment data for polar relays K101 and K110 is listed in table 5-3.

Table 5-3. Polar Relay Adjustment Chart

Reference Designations	K101, K110
Coil Turns	600
Coil Resistance	10
Contact Arrangement	1-C
Tripping Current	2.4 to 5.6mA
Operate and Release Time	1ms
Adjustments	
Contact Screws	Adjusted for 0.004-inch gaps in either armature position
Bias Adjusting Screw	Adjusted to eliminate bias distortion after contact screws are adjusted.
Sensitivity Adjust Screws	Adjusted if trip value in both directions is either low or high.
NOTES	
1. K101 and K110 are identical.	
2. Each relay has two coils which act in opposition.	
3. Coil data applies to both coils of each relay.	
4. To move the armature from one position to the other, the current through the coil tending to move the armature must exceed the current through the coil tending to maintain the armature position, by the tripping current value listed above.	

*

*

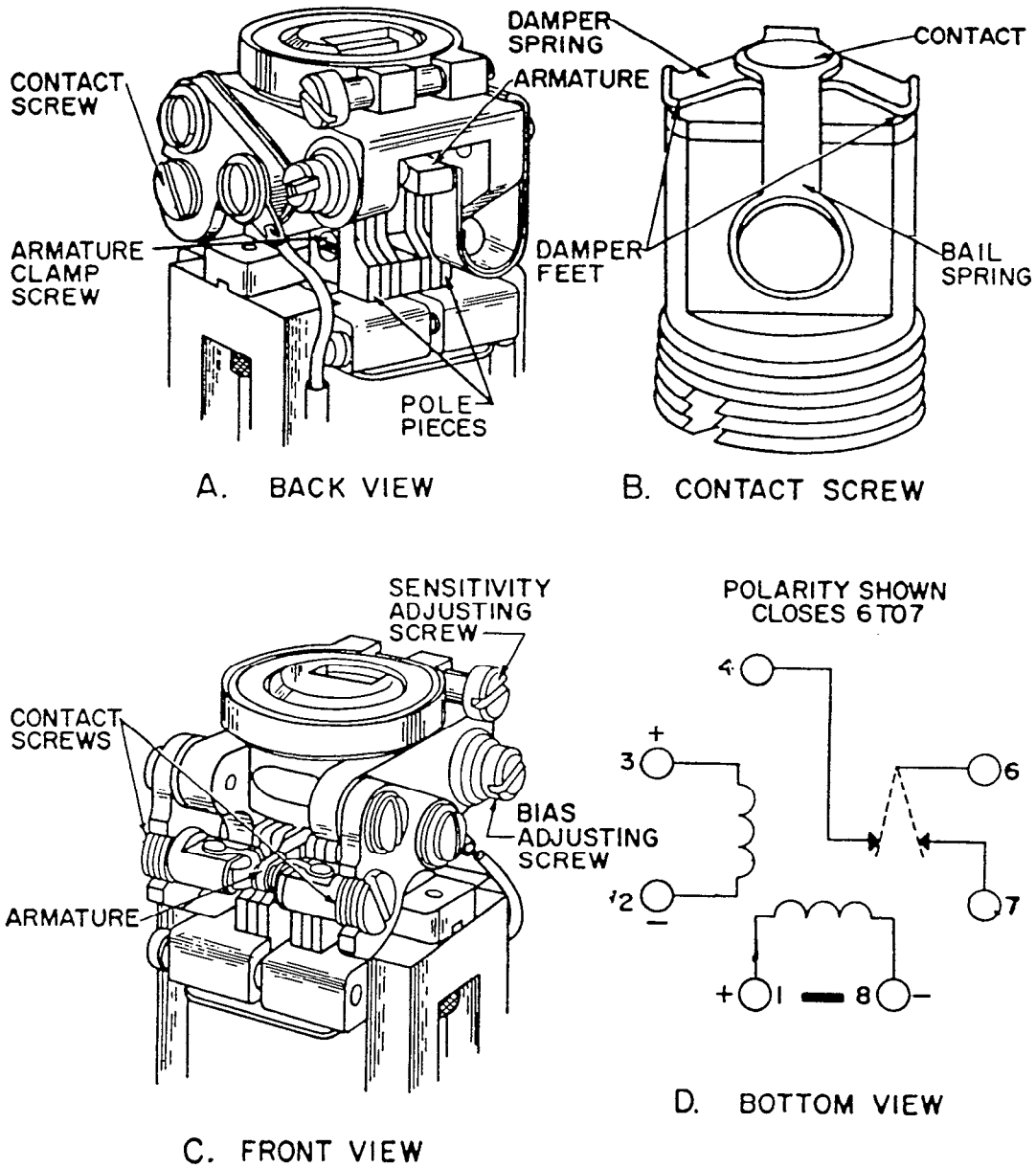
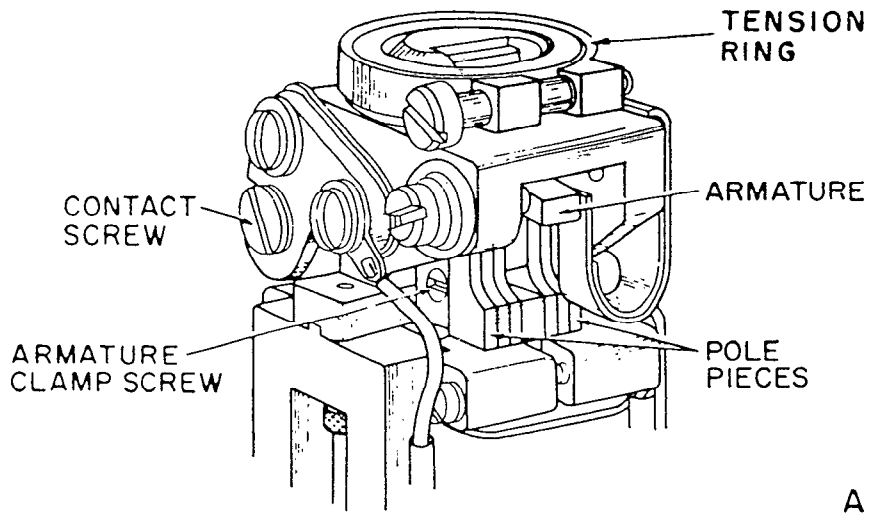

Figure 5-3G. Relay Adjustment Details

*

*



A

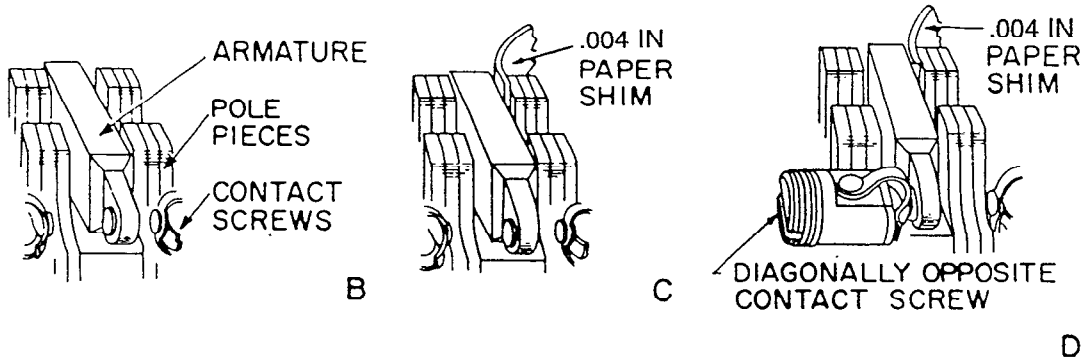

Figure 5-3H. Relay Parts Location

*

* (a) Tools Required.

Screwdriver, jeweler's 1/16-inch blade.

Screwdriver, short, thick handle, 3/16-inch blade.

Shim, paper, 0.004-inch by 1/8-inch strips.

Tweezers, short stiff.

(b) Adjustment Procedure. To Adjust K101 or K110, proceed (referring to figures 5-3G and 5-3H) as follows:

1 Grip the relay base, twist the cover, and lift off.

2 Insert the relay in the relay test set.

3 Unscrew both contact screws (part C, figure 5-3G) until the armature seals on either pole piece (part B, figure 5-3H).

4 From back of the relay, insert one 0.004-inch paper shim (one-eighth inch wide) between the armature and one pole piece (part B, figure 5-3H).

5 Using the relay test set, energize the relay coil as required to make the armature bear on the shim inserted in the previous step.

6 Using the jewelers screwdriver, advance the diagonally opposite contact screw (part D, figure 5-3H), until electrical contact is just made as indicated by test set.

7 Deenergize the relay.

8 Remove the paper shim, and insert it on the other side of the armature. Repeat steps 5 through 7 above.

9 Remove the paper shim.

10 Set the relay test set to measure bias.

11 Adjust the bias adjusting screw (part C,

figure 5-3G) to obtain approximately zero bias distortion.

NOTE: If the bias adjusting screw is backed out, move past the zero adjustment position, hand twist the tension ring (part A, figure 5-3H) clockwise, and advance the bias adjusting to obtain the final adjustment.

13 Back out one contact screw, slightly introducing some bias distortion.

14 Back out the other contact screw slightly to obtain approximately zero bias distortion.

15 Repeat steps 13 and 14 until a 0.004-inch thick paper shim will enter both contact gaps snugly.

16 When 0.004-inch contact gaps have been obtained, use the bias distortion adjusting screw, as in step 12, to remove any remaining bias distortion.

17 Check trip values in both directions. When current is applied only to the coil that tends to move the armature, the armature should switch when the level of applied current is between 2.4 and 5.6mA.

NOTE: If the trip value in one direction is slightly outside tolerance, it may be adjusted by performing the procedure in the note following step 12. If trip values in both directions are high or low, perform the sensitivity adjustment of paragraph 115e(7)(c).

(c) Sensitivity Adjustment Procedure.

NOTE: The sensitivity adjustment is a factory adjustment which should not be tampered with except as specified in the note above.

1 Back out the sensitivity adjusting screw two full turns.

2 Tap the tension ring lightly with a screwdriver handle to remove any backlash.

3 Observe that the tripping current has changed. If no change has occurred, replace the relay. *

* 4 Advance the sensitivity adjusting screw as necessary to obtain a tripping current between 2.4 and 5.6mA.

(d) Replacement of Polar Relay Contacts and Armature.

1 Using screwdriver, remove the contact screws (part C, figure 5-3G).

2 Using the jeweler's screwdriver, back off the armature clamp screw (part A, figure 5-3G) one turn.

3 Remove the armature from the front of the relay by grasping with tweezers and working it forward.

4 Insert the new armature from the back of the relay. Ease it in until the back end is flush with the pole pieces.

5 Tighten the armature clamp screw gently.

6 Insert the contact screws carefully, advancing them just far enough so they are secure.

CAUTION: Do not drop contact screws. If they are dropped, do not use them. Do not advance contact screws far enough to force armature against pole piece or pinch armature between contact screws.

7 If necessary loosen the armature clamp screw, and adjust the armature position for good alignment between armature contact and screw contacts. Retighten the armature clamp screw gently.

8 Adjust relay using procedure of paragraph 115e(7)(b).

116.-119. RESERVED.

*



Section 3. SPECIAL MAINTENANCE PROCEDURES

120. TEST AND ADJUSTMENT OF RELAY 33RY.

- a. **Object.** To test and adjust the 33RY line relay.
- b. **Discussion.**

(1) The following references should be consulted before performing the procedures: (Note, however, that Bulletin 259B is written primarily for procedures using the Automatic Electric SK-27-35A relay test set, which is not available in the FAA.)

(a) Instruction manual for printer test set.

(b) Teletype Corporation Bulletin 259B, Description and Adjustments of 33RY Polar Relay.

(2) Evaluation of the unmodified CA-405 and the CA-1385 printer test sets shows that they have a definite application in the adjustment of the magnetic balance (armature) and the contacts of the 33RY relay. The contact test of the CA-405 results in a meter deflection in excess of 100 divisions. This is due to the tungsten carbide contact material; therefore, this particular test feature will be disregarded.

(3) Do not install or remove the 33RY relay from the printer or test set with the relay cover off. Accidental pressure on the exposed armature spring holder will upset the armature adjustment (magnetic balance).

c. Test Equipment Required.

- (1) Printer test set.
- (2) Miscellaneous relay adjustment tools.

d. **Conditions.** Relay removed from circuit and mounted on the test set.

e. Detailed Procedures.

(1) Relay Test.

(a) Install a 33RY in the printer test set and remove the cover. Arrange the test set for the relay test, but leave the ac off. Alternately hold the mark and space contacts closed with an orangewood stick and adjust the potentiometer or full-scale meter deflection on the contact giving the highest reading. Pitted or dirty contacts will cause unequal deflection or a wavering indication on the meter. Do not clean contacts

at this time. Check the test set batteries if unable to obtain full-scale deflection.

(b) Alternately close the mark and space contacts using the orangewood stick. When the stick is removed, the armature should remain in the selected position. A further check is to turn the ac power on and off repeatedly so that the armature will come to rest on the mark or space contact at random. If this test fails, then the armature magnetic balance is off. The unbalance may be caused by magnetic particles lodged between the pole piece and the armature or the armature spring being out of adjustment or damaged. A complete armature-pole spacing adjustment is required to correct unbalance.

(c) Turn on the ac power and adjust the current to the correct value. The meter should hold at zero $\pm \frac{1}{2}$ division. If the meter fluctuates, the contacts are dirty. If the meter holds two or three divisions from zero, the contact adjustment must be repeated.

(2) Relay Adjustment.

(a) Alignment of the core assembly and coils requires a special nonmagnetic gage. Refer to figure 5-5. Do not upset this adjustment except in an emergency; otherwise, an exchange and repair transaction will be in order.

(b) Refer to figure 5-4 for the armature and contact adjustment tolerances.

(c) Loosen the contact lock screws and back out the contact adjusting screws at least two turns.

(d) If the relay has been in use for some time, the contacts and the armature should be removed for a close examination. Inspect the contact surfaces with a magnifying glass. If it is worn smooth, the part may be reused, but if it is pitted or has a buildup, the part should be discarded. Do NOT attempt to sandpaper, file, or use a stone on the contact surfaces. Wipe the contacts with lint-free cloth.

(e) Remove magnetic particles from the pole piece and the core pieces by pressing a piece of clean, adhesive, electrical tape on the surface and peeling it off. Use the tape ONE time only and do not wipe the surface with the tape.

(f) Install the armature with the mounting screws left loose. If the armature was not removed,

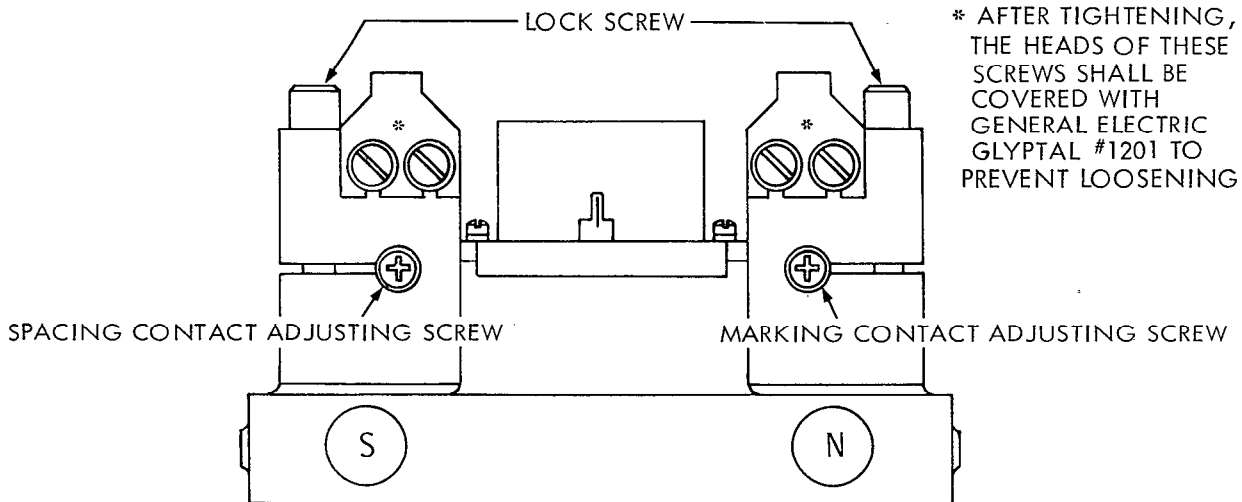
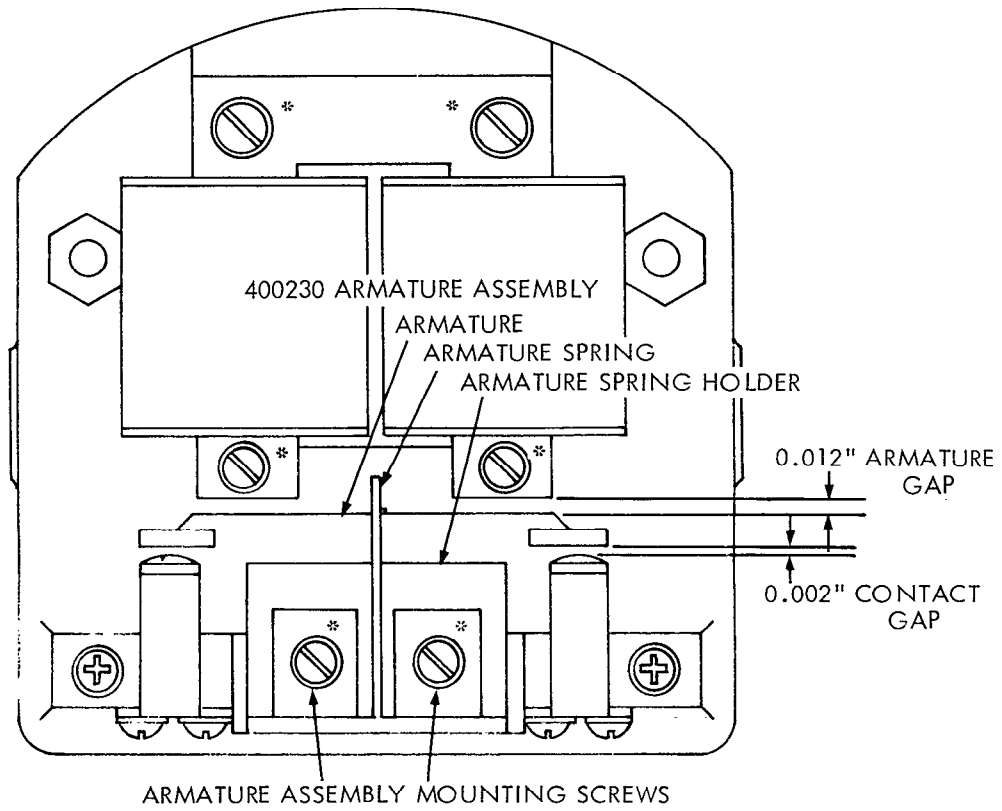
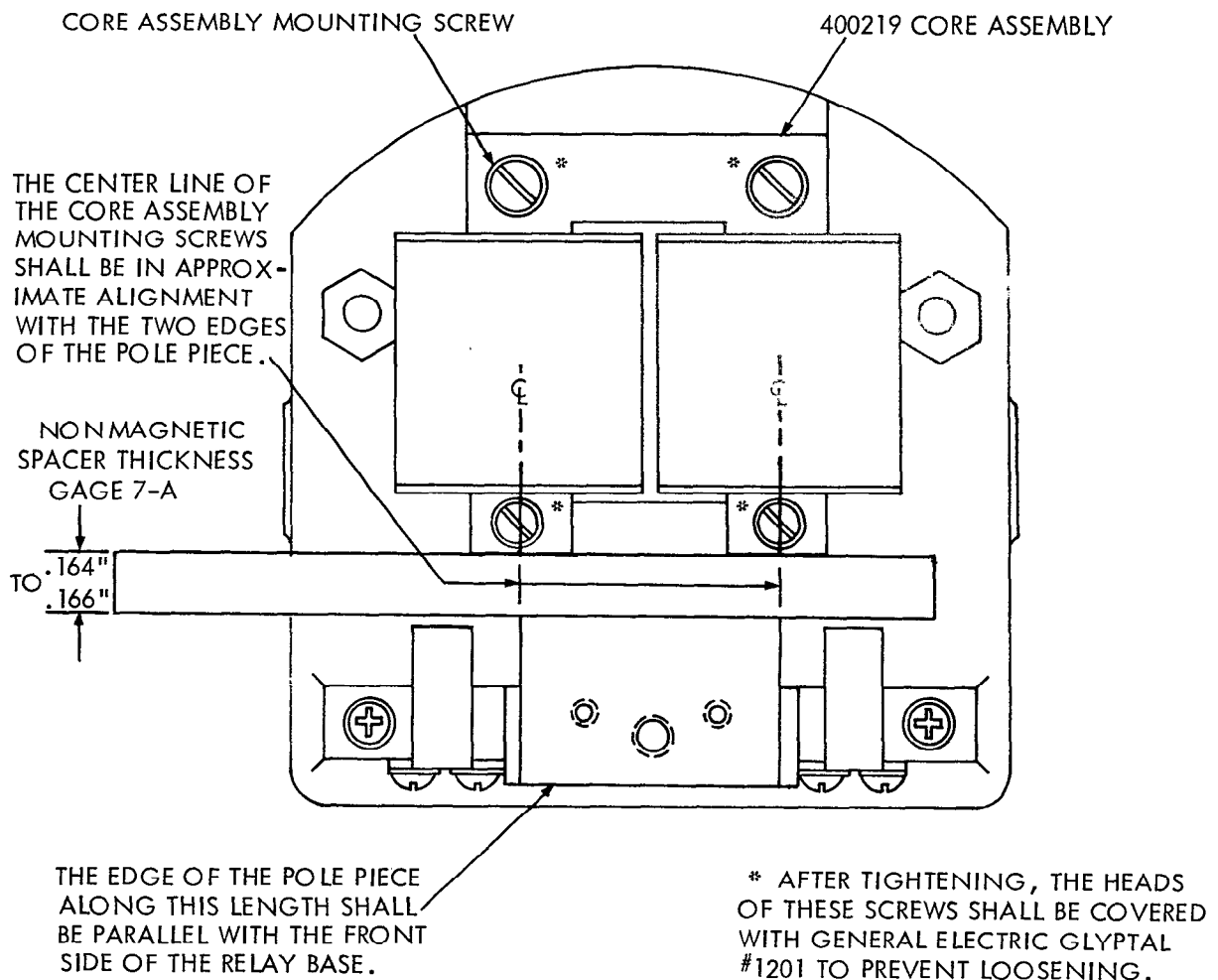

Figure 5-4. Maintenance Adjustments of Relay 33RY



INITIAL ALIGNMENT

THE ALIGNMENT OF THE CORE ASSEMBLY AND POLE PIECE TO THE RELAY BASE IS MADE WITH THE 0.164" SECTION OF THICKNESS GAGE 7-A AT THE TIME OF MANUFACTURE BY POSITIONING THE FOUR CORE ASSEMBLY MOUNTING SCREWS AND THE POLE PIECE MOUNTING SCREW. WHEN THIS ALIGNMENT IS MADE, GENERAL ELECTRIC GLYPTAL #1201 IS APPLIED TO THE CORE ASSEMBLY SCREWS AND THE POLE PIECE IS BONDED TO THE RELAY BASE WITH MINNESOTA MINING AND MFRG. CO. EC-711 METAL TO BAKELITE CEMENT TO ASSURE TIGHTNESS OF THESE PARTS. THIS ALIGNMENT WILL NOT NORMALLY CHANGE AND THESE SCREWS SHALL NOT BE LOOSENED EXCEPT WHERE THIS ALIGNMENT IS FOUND TO BE OFF OR WHEN THE CORE ASSEMBLY IS DISMANTLED FOR REPAIR AND REPLACEMENT OF PARTS. WHEN THIS IS NECESSARY, THE RE-ALIGNMENT SHALL MEET THE ABOVE REQUIREMENTS AND THE PARTS SHALL BE SEALED AS DESCRIBED ABOVE.

Figure 5-5. Initial Alignment of Relay 33RY

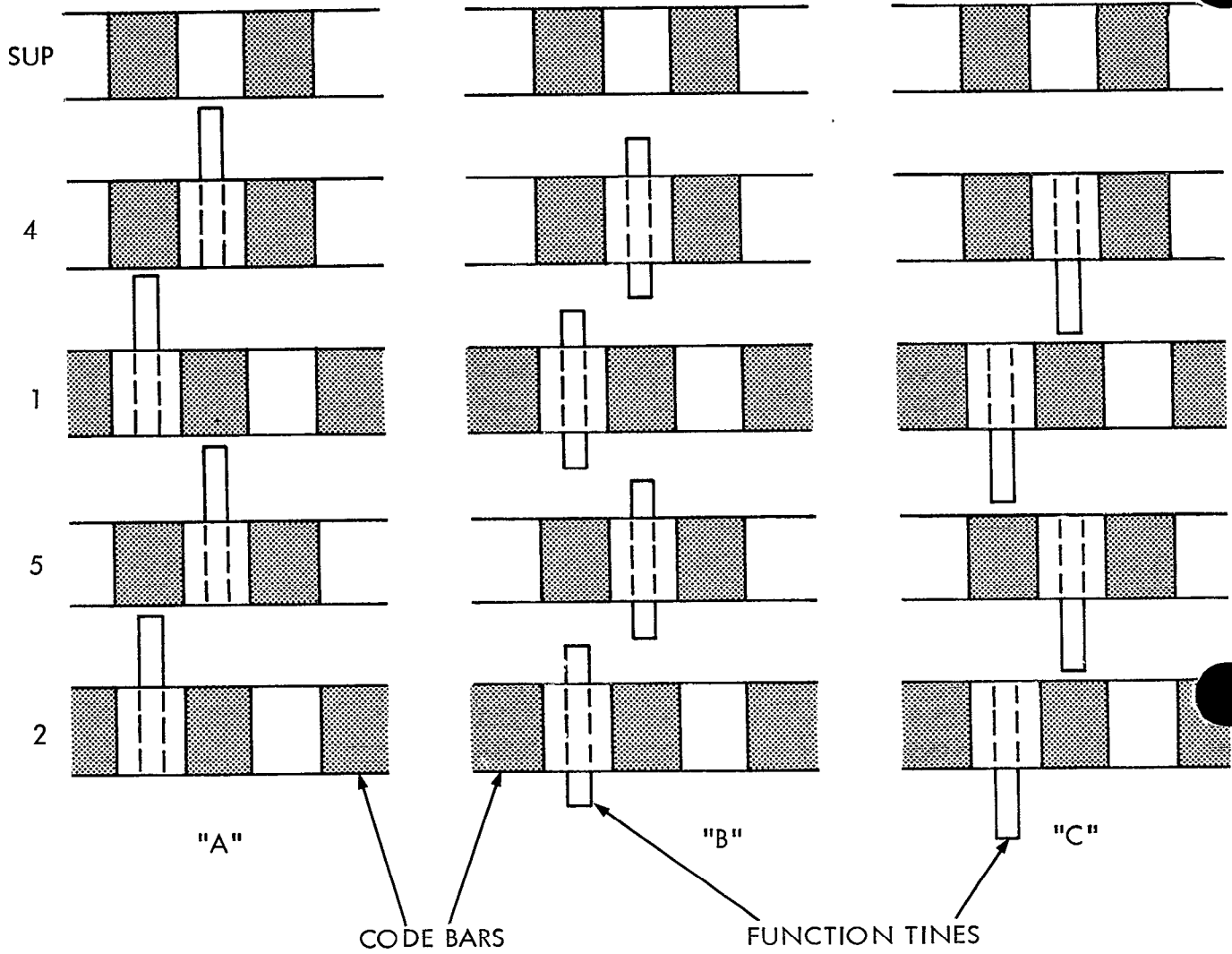

PARTIAL SKETCHES OF FUNCTION TINE - CODE BAR ALIGNMENT AS VIEWED FROM FRONT OF PRINTING UNIT, WITH FRONT PLATE REMOVED. SKETCH IS ENLARGED TO BETTER DISPLAY ALIGNMENT RELATIONSHIPS.

SKETCHES A AND C SHOW INCORRECT ALIGNMENT.
 SKETCH B SHOWS OPTIMUM ALIGNMENT.

Figure 5-6. Alignment of Function Lever Times to Code Bars

loosen the mounting screws. Full freedom of movement is very important.

(g) Place the special dual 0.012-inch armature gage between the armature and both pole pieces. Press both ends of the armature against the gage with the orangewood stick. Align the armature symmetrically with respect to the core pieces. Do not press against the armature spring holder to align the armature. Tighten the armature assembly mounting screws carefully and leave the dual gage in place.

(h) Position the mark and space contacts symmetrically with respect to the contact surfaces on the armature. With the contact adjusting screws, move the mark and space contacts to within 0.002 inch of the armature. Two 0.001-inch thickness gages may be used.

(i) Remove the gages and check the relay as described in relay test. If the armature magnetic balance is off, the adjustments will have to be remade. If the meter deflection from zero is greater than two divisions, the adjustment should be remade. If the meter deflection is less than two divisions, adjust for an indication of zero by increasing whichever contact gap will produce the desired results. Do not decrease the contact gap to less than 0.002 inch because undesirable arcing may occur. If the meter deflection fluctuates several divisions rapidly or drifts several divisions slowly, the adjustments should be remade.

(j) Install the relay in a printer known to be in good condition and observe the printer's operation. Check the RAS range of the printer and compare it with previous operations.

121. CODE BAR TO FUNCTION TINE ALIGNMENT.

a. **Object.** To adjust the alignment of code bars for positive control of the stunt box functions.

b. **Discussion.** Proper alignment of code bars to function tines is required for positive control of the stunt box functions. Excessive misalignment is characterized by intermittent and extraneous function selections while the printing operation remains normal. Abnormal function selections may appear as infrequent intermittent misses and may be associated with functions on the left side, right side, or in the middle of the stunt box depending on the code bars to function tines alignment in those areas.

c. **Test Equipment Required.** Teletypewriter tools.

d. **Conditions.** Printer removed from circuit.

e. **Detailed Procedures.**

(1) Alignment of the code bars to function tines must be checked with the front plate removed. This adjustment should be such that each function tine clears the adjacent code bar by at least 0.020-inch when the tine is positioned manually for minimum clearance. Adjacent code bars are those above or below the code bar used to operate the function tine in question. See figure 5-6.

(2) When correct clearance cannot be achieved, parts with excessive wear should be replaced. Excessive wear on the following parts affects clearances:

(a) The stunt box guide plate 152651 may wear in the bottom of the groove from the function tine sliding action.

(b) The function tines may wear at points of contact with the code bars and the guide plate.

(c) The code bar brackets 152576 (right side) and 152575 (left side) may wear in their respective holes and slots from the guides on the stunt box. The brackets may also wear into the code bar slots from sliding action of the code bar.

(d) The guide bracket 150304 may wear in the slots receiving the code bars.

(3) When adequate clearance cannot be obtained by replacing worn parts, the following adjustments are applicable:

(a) When alignment of code bars to function tines is within tolerance at the left and the right sides but out of tolerance in the center portion, raise or lower guide bracket 150304. The guide bracket is raised by inserting spacers between tie bracket 153321 and code bar brackets 152575 and 152576. The guide bracket is lowered by inserting spacers between guide bracket 150304 and tie bracket 153321. Retainer rings 119652 may be used as spacers. The rings may be inserted without complete removal of the screws.

(b) Minor changes in code bar to function tine alignment can be obtained by the positioning of side brackets 152627 and 152626 on the stunt box assembly. The side brackets can be moved about the mounting screws 151657 after the screws are loosened. The loose fit of the side brackets allows rotational play

about the screws. Raising the front part of the side bracket lowers the brackets to retain the desired adjustment.

f. **Testing Code Bar and Transfer Lever Selections.** Tape can be prepared to operate the M28 printer code bars and transfer levers at slow speed, which will materially aid in the diagnosis of intermittent trouble by observing the travel and frequency of the selected functions. Punch a test tape with the following group of characters:

5 CR's.....	5 blank spaces.....	(5 times)
5 E's.....	5 blank spaces.....	(5 times)
5 T's.....	5 blank spaces.....	(5 times)
5 LF's.....	5 blank spaces.....	(5 times)
5 LTR's.....	5 blank spaces.....	(5 times)

With the test tape in operation, observe code bar operation recalling a mark signal moves the code bars to the left and a space signal moves the code bars to the right.

122. ASR CHECKOUT PROCEDURES.

a. Subassemblies.

(1) Place keyboard control knob in K position. Observe lights on all code combinations, proceed with the checkout procedures for the M28 printer.

(2) If during the sending of M's or A's the printer garbles, try K-T position; now, if the operation is satisfactory, the trouble lies in the keyboard, not in the printer.

(3) If no problems occur during the checkout procedure in K position, go to the K-T position; again depress M's and repeat key lever, A's and repeat key lever. Printer and perforator should both operate correctly.

(4) Now turn control knob to T position; perforator should operate only. Depress A's and repeat key lever, M's and repeat key lever.

(5) Turn control knob back to K position. Remove the test tape made while in K-T and T positions, which is a series of M's and A's. Place in TD.

(6) Depress manual start button on control panel; TD should start and transmit M's and A's. Quickly check tight tape; TD should stop.

(7) Depress manual start button, and quickly depress manual stop button; TD should stop.

(8) Repeat step (7), only this time check start-stop lever.

(9) Tape should be nearly through TD. Again, start TD and let tape run all the way through TD to check end-of-tape switch.

b. **Relay Control Group.** If by this time no trouble has become apparent, the trouble must be in the relay control group.

(1) Reinstall tape in TD. Depress a green character code key lever and the repeat key lever; this should indicate a busy line condition. Depress TD start button, and upon releasing the repeat key lever, the BL relay should time out, and the TD should start transmitting. This action checked out the request-to-start relay to see if it would hold a request-to-start during a busy line condition.

(2) To check out the OL relay, reinstall the tape in TD and initiate a busy line by depressing a green character code key lever and the repeat key lever. Depress manual TD start button, still holding repeat key lever down. Now depress and hold the line-break button in excess of two character lengths, then release the repeat key lever. After the line-break button has been held down long enough to note open-line-light flashing, release the line-break button. The TD should not start. If contacts 1 and 2 make on the OL relay, to cause RS-1 relay to drop back out, the TD should not start.

NOTE: If a malfunction is noted during any step of the checkout procedure, proceed to the next step so as to have a better picture of the symptom.

123. PRINTER TROUBLESHOOTING PROCEDURE.

a. **Printer Checkout.** Determine if the printer is functioning properly by:

(1) LOCAL-REMOTE switch in LOCAL.

(2) LINE-TEST switch in LINE position (make sure you are on TEST loop, usually line 9 or 10 on TLSU).

(3) Keyboard ON-OFF switch in ON position.

(4) Keyboard control knob in K position.

(5) Observe BL light and OL light (should both be out).

(6) Start with character M and the REPEAT key lever depressed. Print about a half a line.

(7) Now depress character A key lever and REPEAT key lever, printing to extreme right-hand margin to check for the following automatic carriage return (CR) and automatic line feed (LF).

(8) Now check Reg CR key lever.

(9) Now check Reg LF key lever. Both should function properly.

(10) Try letters figure shift. At this time if machine has failed, proceed to the "T for Texas" check procedure to be able to isolate problems of maladjustment, vertical or horizontal positioning, or problems with the stunt box.

b. "T for Texas" Check Procedure. This check will aid in determining the particular pulse or the particular function that is causing a problem. By sending a series of letters (12345), the check is for all mark plus letters shift. The code for blank (----) checks all pulses for a condition of all spaces. The character E (1---) checks pulse No. 1 by itself, and LF (-2---) checks pulse No. 2 plus the function for LF. The code for space (-3-) checks pulse No. 3 on an individual basis. The code for CR (---4) checks the function CR plus the No. 4 pulse by itself. The character T (---5) checks pulse

No. 5 on an individual basis, etc., with the remaining characters as outlined in figure 5-7.

NOTE: The BL light should always be on for any and all codes selected.

c. Selective Calling Check Procedure.

(1) Place LOCAL-REMOTE switch in REMOTE. Send EOM (NNNN). If K-18 operates properly, printer should now be in remote. To check, try to print two or more A's. If printer fails to go in remote, the trouble is the EOM code, stunt box.

(2) With printer in remote, send conditioning code ($\equiv < \downarrow$) plus station call. Printer should come out of suppression and copy several characters. If printer performs properly, send EOM (NNNN).

(3) With printer in remote, send conditioning code ($\equiv < \downarrow$) plus area call. Again printer should stay out of suppression; send EOM, placing printer again in suppression.

(4) TD Call Check. Hold Finger down on EOT pin.

(5) Send conditioning code ($\equiv < \downarrow$) followed by two-letter TD call to check K-10 in stunt box. TD should start transmitting. Release EOT pin, TD should stop.

LETTERS CATEGORY

M --345			Space --3--	Blank ----	T ----5	CR ---4-	
				E 1----			
				LF -2----			
Ltr 12345				A 12---			Fig 12-45

Figure 5-7. "T for Texas" Type Box Check

(6) Send EOM (NNNN). Printer is now back in suppression.

(7) Send (<<↓) CR, CR, LTR plus station call to check slots 12, 13, and 14 in stunt box. If after typing a few M's there is no problem, the printer checkout is complete.

124. TRANSMITTER-DISTRIBUTOR CONTACT ADJUSTMENT USING DTS-531P.

a. **Object.** Adjustment of the transmitter-distributor contacts using the DTS-531P distortion analyzer.

b. **Discussion.** Because the DTS-531P displays the magnitude of distortion in each pulse, it is possible to dynamically adjust the distributor contacts.

c. **Test Equipment Required.** DTS-531P distortion test set.

d. **Conditions.** Insure that the DTS-531P (an analyzer) has been calibrated for 74.2-baud rate in accordance with paragraph 125.

e. Detailed Procedures.

(1) Before plugging into TTY loop, turn all five distributor information pulse contacts counterclockwise to make no contact when the TD is running.

(2) Plug analyzer into loop and start the TD with letters code being sent. Be sure the TD is started after plugging in analyzer to insure their being in step.

(3) Adjust the LED in the seventh spiral to align with the first spiral by adjusting the start/stop control screw of TD.

(4) Adjust No. 1 distributor signal contact until second spiral LED aligns with first.

(5) Now adjust the No. 2 distributor contact screw inward until LED's in the third spiral appear. (There may be LED's lighted in the fourth, fifth, sixth, and seventh spirals, but ignore them at this point.) When LED's light in the third spiral, when adjusting the No. 2 contact, keep rotating until the one approaching from the right in the third spiral just disappears; then turn the contact screw an additional one-eighth turn inward. The No. 2 contact is now adjusted.

(6) Now, adjust the No. 3 distributor contact screw the same way while watching the LED in the

fourth spiral as it approaches from the right. As before, when this LED just disappears, rotate the No. 3 contact an additional one-eighth turn. The No. 3 contact is now adjusted.

(7) Adjust No. 4 contact the same way, while watching the LED in the fifth spiral approaching from the right.

(8) Finally adjust No. 5 the same way while watching the LED in the sixth spiral and seventh spiral. Turn No. 5 inward until the LED's in the sixth and seventh spiral just disappear.

(9) Disconnect analyzer from loop.

(10) Run a "Mary 4679" tape through the TD. There should be 4 percent or less distortion present in the transmitted signal.

125. CALIBRATION OF DTS-531P FOR 74.2 BAUD RATE.

a. **Object.** Calibration of the DTS-531P analyzer oscillator for acceptance of a 74.2-baud rate teletypewriter signal.

b. **Discussion.** The DTS-531P analyzer set at 75-baud modulation rate is not compatible with a 74.2-baud M28 teletypewriter loop. Therefore, it is necessary to calibrate the analyzer circuit using the generator circuit.

c. Test Equipment Required.

(1) Model DTS-531P distortion test set.

(2) Associated interconnecting leads (phone plug at each end).

d. Conditions.

(1) Turn on test set and allow a 15-minute warm-up. DO NOT interconnect analyzer and generator.

(2) Set switches on analyzer to the following:

(a) Display switch at ALL

(b) Mode switch at START/STOP.

(c) Unit code switch at 5.

(d) Modulation rate switch at 75.

(e) Oscillator switch coarse knob clockwise from the fixed position.

(f) Current potentiometer (not used).

(g) Polar/neutral switch at POLAR.

(h) Mark polarity switch at POSITIVE.

(i) Input switch at 1.

(3) Set the switches and controls on the generator to the following:

(a) Data out switch at $\pm 6V$.

1 Distortion percent switches at zero.

2 Distortion select switch (not used).

(b) Modulation rate switches.

1 Fixed switch at 75.

2 Variable potentiometer (not used).

3 Select switch at FIXED.

(c) Polarity switch at POSITIVE.

(d) Parity switch (not used).

(e) Stop interval switch at 2.

(f) Transmit switch at CONT.

(g) Format switch at ITA 2.

(h) Message switch at CHAR 1.

1 Character No. 1 bit selector switches set to the letter Y.

2 Character No. 2 bit selector switches (not used).

e. Procedures.

(1) Use the phone plug interconnecting lead and connect the data out phone jack on the generator to the input phone jack of the analyzer. As this is done, there will be a random array of LED's (light emitting diodes) displayed on the analyzer face.

(2) Adjust the COARSE and FINE oscillator control knobs until the LED's are aligned at the center top of the display face as shown in figure 5-8, item A. (If all six LED's are not at the top of the display as shown, but some are at the top and some are directly opposite at the bottom, flip the generator mark polarity switch back and forth until they do line up at the top as shown in figure 5-8.) Figure 5-8, item B, shows this relationship to the letter Y transitions.

(3) If the second LED from the top were at the left of center at the 2 percent mark, the generator oscillator would be leading the analyzer oscillator by 2 percent of a baud length.

(4) Now adjust the analyzer variable oscillator until the pattern shown in figure 5-9 is obtained. Note: If pattern is unobtainable, change analyzer modulation switch to 61.1 bauds and adjust oscillator pot to desired pattern.)

(5) It has been observed that if the third LED from the top has just moved left, the generator oscillator is very close to 1 percent leading in baud length. Further observations revealed that with the pattern shown in figure 5-9, the baud rate of the analyzer oscillator is very close to the 74.2-baud rate required by the M28 system. (Percentage baud-length relationship between 75 bauds and 74.2 bauds is roughly 1.078 percent.)

(6) With the pattern of figure 5-9 carefully adjusted into position, unplug the phone plug lead from the generator and flip the polar/neutral switch on the analyzer to neutral. The analyzer is now ready to be used in the loop of an M28 circuit. (For 60 mA line current, the current potentiometer on the analyzer should be set to the line mark above its knob.)

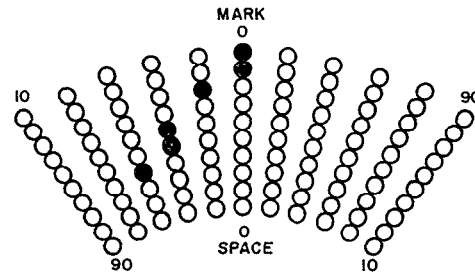
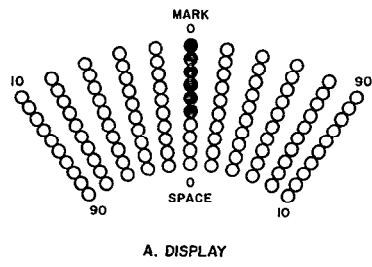

Figure 5-9. DTS-531P Analyzer Properly Calibrated

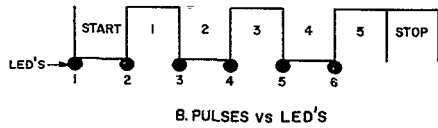

Figure 5-8. DTS-531P Analyzer Oscillator and Generator Oscillator at Same Baud Rate

126.-139. RESERVED.

CHAPTER 6. MISCELLANEOUS

140. AUTHORIZED EQUIPMENT MODIFICATIONS.

The authorized modifications applicable to the teletypewriter equipment will be found in Order 6170.1, Electronic Equipment Modification Handbook Data Handling Equipment.

141. MERCURY-WETTED CONTACT KEYING RELAYS.

a. Mercury-wetted contact keying relays, previously used as replacements for the type 33RY line relay, are unsatisfactory for this purpose in electromechanical equipment cabinets and enclosures and are not authorized. Mechanical vibration transmitted in teletypewriter enclosures and in racks or panels adjacent to such equipment adversely affects the capillary flow of mercury to the contacts. This characteristic has been established by laboratory tests made by the teletypewriter equipment manufacturers, who do not authorize such relays in their electromechanical equipment.

b. An additional problem of mercury contact relays is in contact rating, which is unsuitable for the very high surge current originating in the line monitor send control relay group associated with teletypewriter equipment. The type 33RY successfully handles this current. Design variables in mercury contact coating result in insufficiently positive contact action and lost pulses may occur in some applications of the relay. Furthermore, teletypewriter equipment manufacturers cannot specify an individual adjustment for each teletypewriter selector, needed by mercury contact relays, to account for the variations from machine to machine.

c. Mercury contact relays will be authorized for installation and/or facilities modernization projects, including special maintenance projects, guided by the availability of vibration-free enclosures, panels, or equipment cabinets, and the need for RFI elimination and COMSEC equipment isolation. The casual employment of the mercury contact relay as a replacement for the type 33RY relay is prohibited.

142. GUIDE-PLATE WEAR.

Teletype Corporation has designed a steel strip, part No. 195109, to compensate for part No. 153322 "guide-plate" wear. This wear is evidenced by an indenta-

tion (approximately 1/64 inch) at the point of contact between the guide plate and function levers (part Nos. 152121, 152641, 154647, 157207, etc.). The steel strip may be ordered from the FAA Depot, listing the part number 195109 and the national stock number 5815-00-055-6988 on the requisition. The steel plate should be installed on the top of the guide plate so that it will stop the forward movement of function levers in lieu of the guide plate acting as a stop.

143. FACTORS AFFECTING PRINTER MARK-SPACE CURRENTS.

Reports have been received indicating excessive variation in marking and spacing currents. Where this situation exists, a check should be made to determine that the 2750 ohm resistor in series with the marking contact of the 33RY relay is actually shorted out by a jumper as shown in the standard drawings. Another possibility of wiring error is the center-tapped, 3500/2000 ohm resistors being mounted and wired in reverse (end for end). Refer to drawing 3434-WD, line relay mounting assembly, station J. Bulletins 216B, and 246B, description and theory of M28 printer and typing reperforator, and figure 6-1, show that the typing unit selector magnets current is 30mA for FAA systems; therefore, the magnets should be connected in series.

144. LINE SWITCHING UNIT CA-1696.

The following maintenance instructions apply to all CA-1696 teletypewriter line switching units.

a. KS7471 grease may be used for the pushbutton assemblies in place of the lubricant specified in the instruction book. Lubricate per instructions in Section 6, Preventive Maintenance, and per instructions in paragraph 1.3, Section 7, Corrective Maintenance, of the instruction book. Refer to sections 5 and 6 of the instruction book for detailed lubrication instructions.

b. Metal filings are produced by the rotation of panel mounting screws during removal of switching units. The metal filings fall into any switching units that may have been loosened and partly withdrawn. To correct this:

(1) Loosen and remove every switch from the rack.

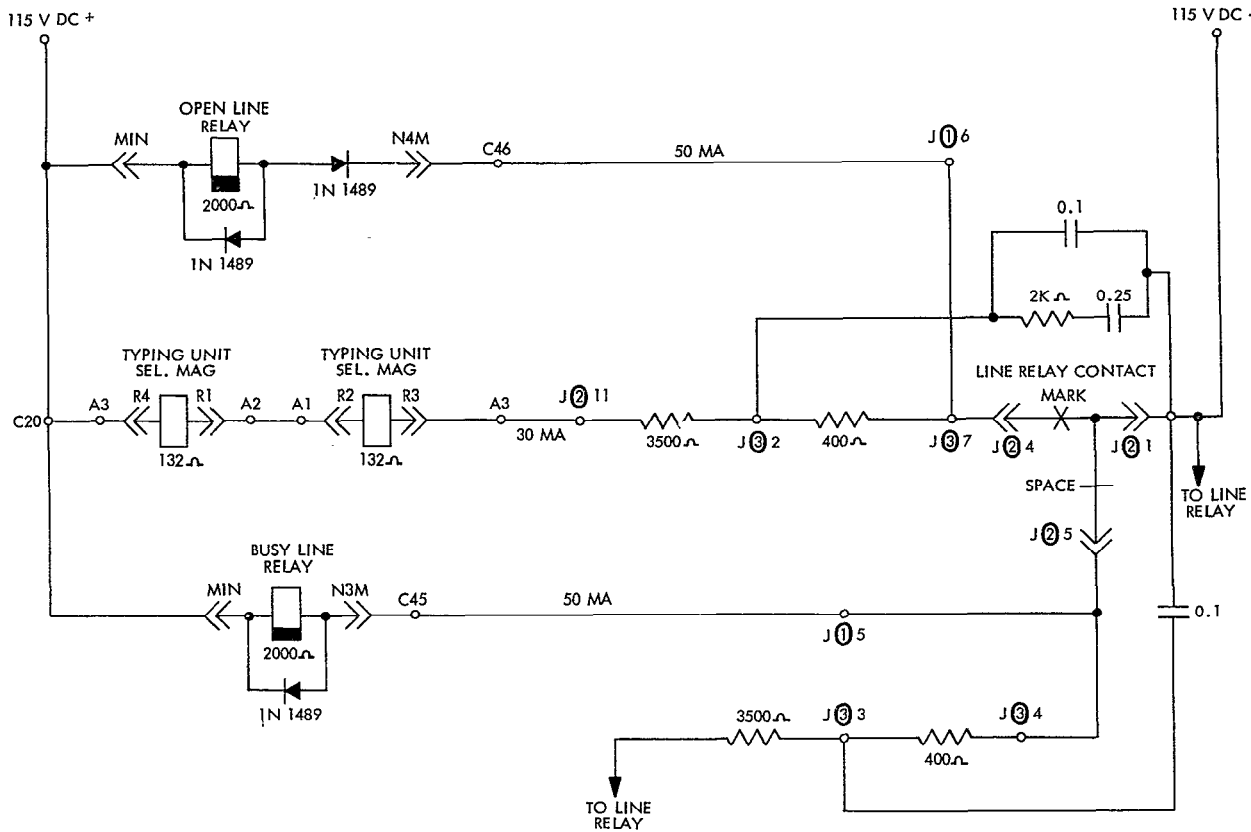

Figure 6-1. FAA Standard Relay Control Group Schematic Diagram

CAUTION: Check condition of wiring harness before attempting to remove contact pileups. If brittle, etc., any attempt to remove will cause additional problems. Recommended solution: replace CA-1696 unit.

(2) Lubricate the switch units using KS7471 grease between the panel mounting screw and washer, between the Tru Arc ring and panel, and on the threads of each mounting screw. If the washer is not stuck to the paint, lubricate between washer and the panel. Lubricate the top of the slides.

(3) The insulation spacer between the actuating arm and the No. 1 contact leaf of the S-3 pileups should be inspected periodically for wear or flattening. This could expose the rivet holding the spacer to the contact leaf, thus allowing the rivet to make contact with the actuating arm. This causes a ground or intermittent ground on the signal

line. Added insulation can be provided by cutting a 3/8-inch by 3/8-inch (1.0 by 1.0cm) square of Scotch's No. 33 (or equivalent) electrical tape. Using long-nose pliers, carefully apply one piece of tape on the actuating arm of each line switch and on the bottom actuating arm of the access switch. The tape is applied to the actuating arm directly under the insulating spacer riveted to the 1t and 1b contact spring.

145. TELETYPE CORPORATION BULLETIN PROCUREMENT.

Appendix 4 provides NSN's for the most commonly used equipment documentation. If it is necessary to obtain an NSN for documentation not listed, the following documents should be obtained:

NSN	Title
0056-00-349-9000	Depot-stocked Teletype bulletin sections

0056-00-301-2000 Index of sectionalized
technical publications
(Teletype Corporation)

NOTE: With these documents it is possible to obtain the NSN of any sectionalized publication that Teletype Corporation provides.

146. COMSEC PUBLICATIONS.

The latest editions of the following documents delineate FAA guidelines and policies pertaining to secure communications systems:

<i>Order</i>	<i>Title</i>
7330.4	FAA Operation in the Automatic Digital Network (AUTODIN) and Use of the ADONIS System
7610.4	Special Military Operations
1600.1	Personnel Security Program
1600.2	Classification, Declassification and Control of National Security Information
1600.6	Protection of Agency Property
1600.8	Communication Security (COMSEC) Handbook
1600.12	Technical Security Countermeasures Program

1600.15 Control and Protection of "For Official Use Only" Information

MIL-HDBK-232 Military Standardization Handbook – Red/Black Engineering – Installation Guidelines

6170.7 Installation and Maintenance of COMSEC Equipment

NOTE: The listing of the above in this handbook does not automatically justify access to controlled, restricted, or classified documents.

147. TELETYPEWRITER STANDARD DRAWING PROCUREMENT.

Since the FAA Depot is the custodian of all teletypewriter drawings, the depot drafting department should be contacted for any request for current drawings. Correspondence should be directed to:

Mike Monroney Aeronautical Center
AAC-445A
P. O. Box 25082
Oklahoma City, Oklahoma 73125

NOTE: A list of the most current drawing numbers and their titles is provided in appendixes 2 and 3.

APPENDIX 1. GLOSSARY

Align. To adjust to form a line; to set to equivalent specifications.

ASR. Abbreviation for "automatic send-receive," as applied to a teletypewriter set, consisting of a printer, keyboard, tape handling equipment, and line relay group (selective signaling) equipment. The ASR is a complete message center and is the standard telecommunication device for administrative, weather, AUTODIN, AMOS, IBM 9020 CCC, and ARTS applications.

Asynchronous. Having a variable time interval between successive bits, characters, or events. The term asynchronous is usually applied to serial start-stop transmission.

ASCII. Pronounced "askee", this is an acronym for "American Standard Code for Information Interchange." It is the accepted term, although a more recent title is "USA Standard Code for Information Interchange" (USACII). It has 128 possible information and function combinations. See Eight-Level Code in this glossary.

Bellcrank. A bent lever, having its fulcrum at the bend and used to change direction of motion. A lever having arms, which form an angle, and which has its fulcrum at the apex of the angle. It is normally used to change the direction of linear motion.

Bail. Usually an arched unit pivoted at two points located on the same axis; used to deliver motion to some other unit.

Bias. The effect of distortion whereby one type of pulse becomes longer while the opposite type of pulse is shortened.

Blinding. The automatic suppression of unwanted functions or selective calling signals (e.g. address codes of other than the local station) from appearance in printer copy or punched tape.

Bulletin. Name given to a single publication by Teletype Corporation covering description, operation, parts, or maintenance of an apparatus.

Bushing. A metallic sleeve or cylinder inserted in a larger component of a machine. The bushing receives the wear caused by the moving part it supports and it is replaceable.

Busy Line. The condition of a signal line that is carrying intelligence pulses.

Cam. A surface on a shaft or wheel, which is not a true circle; there being one or more areas of the surface which are either raised or lowered from the average circumference line.

Centrifugal. Acting away from the center. Usually used to describe a force created by the rotation of a body.

Character. A Baudot code sequence, consisting of a start pulse (space), 5 variable pulses (mark or space), and a stop pulse (mark), which can represent a letter or function, such as: A, B, CR, LF, etc.

Clutch. A device for mechanically engaging and disengaging parts for transfer of motion.

Codes. The language used to translate keyswitch depressions into signal logic output. The standard data handling codes in FAA include USA standard code for information interchange (ASCII) and Baudot (a personal name). The former is an eight-level code with a parity bit and start-stop bits, and the latter a five-level code using start-stop bits in addition to the five intelligence bits.

Comsec. A contraction for "communication security" commonly applied to equipment and/or systems for encryption, transmission, and decryption of classified messages or data.

Conditioning. The process of receiving certain code characters which will in turn allow a station to copy only those messages intended for that station.

Damping. A progressive reduction of motion of a moving part. Electrically, the progressive reduction of amplitude of wave motion.

Dashpot. A device used to cause damping or deceleration in a mechanism. Usually an air or oil-filled cylinder with a piston having metered holes.

Decelerate. To reduce the speed of an object. Negative acceleration.

Demarcation. Boundary. Used to describe a terminal strip at which connections are made between

the telephone company's circuits and those of the customer.

Detent. A device, usually spring loaded, such as an arm or pin or roller, used to hold a mechanism in place after it has been positioned.

Differential. Pertaining to, or involving, a difference. A differential current device depends upon the difference in two current values to determine its action.

Disk. A thin, flat, circular object made of any material.

Distortion. A change or alteration of normal shape. Electrically, a change produced, usually unintentionally, in a waveform.

Distributor. A device used to transmit electrical pulses in a definite order to the signal line.

Draglink. A specific lever used in the perforator and reperforator. It has a fixed pivot point at one end; the other end is used to limit the travel of a toggle link to one plane of movement.

Drum. A metal cylinder, such as the one around which a wire rope is wound. Another application is in clutches when the shoes contact the inside walls of a cylinder.

EBCDIC. Pronounced "ebseedick," an acronym for "Extended Binary Coded Decimal for Information Code," an eight-level code with 256 possible information and function combinations.

Eccentric. A device which has its center of movement located away from its physical center.

Eccentric Stud or Screw. A machine screw or bolt having a smooth surface between the head and the threads. The threaded portion has its center offset from the center line of the smooth portion. Frequently used to adjust the position of a member, having a slot into which the eccentric stud is inserted, by rotating the stud as needed.

Eight-Level Code. A code used for data transmission having seven intelligence bits, one parity bit, one start bit, and two stop bits. The ASCII (or USASCII) is an example of this code.

EIA RS-232. An Electronic Industries Association (EIA) specification concerning the voltage interface re-

quirements between data-handling terminal equipment and data communication channel equipment. The standard defines a means of exchanging control signals and serial binary data signals between terminal and communications equipment. Letter suffixes indicate the latest edition.

End Distortion. That type of distortion, not normally encountered, that either adds to or subtracts from the trailing edge of the numbered marking pulses.

Expansion Clutch. A clutch that operates on the principal of spreading clutch shoes apart or outward to engage with the inside surface of a drum. The shoes are attached to a sleeve, while the drum is attached to a shaft which is rotating. Clutch engagement causes the sleeve to turn.

Five-Level Code. A code used for data transmission having five intelligence bits, one start bit, and one stop bit. The latter is normally 1.42 times the length of the other bits to allow for differences in machine timing. The BAUDOT is an example of this code.

Fortuitous. Happening by chance, accidental, not planned.

Fortuitous Distortion. A random and intermittent form of distortion, such as might be caused by lightning.

Framing Bits. Usually, the start and stop elements of a signaling code consisting of one character.

Friction. The resistance or opposition offered to one body moving relative to another with which it is in contact.

Friction Clutch. A clutch which depends upon the friction between two or more disks to deliver motion from one component to another. Pressure is applied to one set of the disks so that they engage with the other set; one set being driven and the other being attached to the unit to be driven.

Full Duplex. A circuit on which information can be transmitted in two directions, with each direction independent of the other.

Function. The mechanical operations performed within the typing unit which result in non-printing operations such as: line feed, carriage return, letters-figures shift, signal bell, etc.

Fulcrum. The support or point of support on which a lever moves.

Gap. A hole, opening, or space, such as the distance between two objects or surfaces.

Garble. A distorted or interrupted transmitted code sequence which results in an unreadable copy of the transmission.

Gauge (or Gage). A standard used for a scale of measurement. The tool so used.

Ground Rules. Standards, conventions, or practices recognized by the FAA and a leasing or serving company for the interconnection of leased and customer-owned teletypewriter circuits or equipment.

Half Duplex. A circuit on which information can be transmitted in either direction, but in only one direction at a time.

Hard Copy. Paper printout of a data-handling terminal.

Helical. Spiraled; being similar to the threads of a bolt; the path travelled by a point on a rotating object which is moving in a direction which is at a right angle to the plane of rotation.

Helical Gear. A gear having helical teeth; a gear having teeth cut at an angle, other than 90°, to the plane of its rotation.

Hit. A momentary disturbance on a circuit. In data communication, a hit duration less than a bit length may garble one or more characters, particularly in an asynchronous mechanical selector system.

Horizontal Positioning. The process by which the type box is moved horizontally.

Idle Line. A teletypewriter transmission line that is in a steady-state marking condition, a closed loop or circuit having normal continuous current flow for a period greater than the time required to transmit a complete character, this time being 100 milliseconds when operating at 100 words per minute.

Indent. A depression, dent, or low area on a body.

Inertia. The opposition offered by a body to a change in its state of motion.

Information Bits. The signal elements of a character carrying the intelligence, as contrasted with framing bits used as start-stop elements.

Keyboard. An assembly having the appearance of a typewriter's front section. It contains the keys which are depressed to directly control a teleprinter system or to control a perforating mechanism.

Keyboard Control. The system of cams, links, and other mechanisms used to control or direct the output of a keyboard.

Klixon. A thermal sensitive device, the element of which is convex in shape, used to open a circuit in the event of overload. It is the trade name of the circuit breaker used in the Teletype Corporation equipment for motor protection. It may be reset manually.

Knurl. A machining process which produces a rough surface on an object making it easier to grasp with the fingers.

KSR. Abbreviation for "keyboard send-receive," as applied to a teletypewriter. The printing unit prepares hard copy; the keyboard unit transmits manually-entered information. There is no paper tape capability. The KSR operates in either half-duplex or full-duplex configuration on a circuit.

Latch. A lever, or bar with a notch or slot, or a hook used to engage some part to prevent its motion.

Letters Category. That part of the typebox containing pallets bearing the letters. This term also applies to the positioning of the printer components to print in the "Letters Case"

Lever. An arm, rod, or bar which is pivoted about some point called the fulcrum and which is used to transfer motion from one component to another.

Line. Sometimes referred to as the signal line or telephone line. It is the metallic circuit between the sending station and the receiving station, used to carry the current for operation of the printer.

Line Current. The direct current in the line at a given time, measured in milliamperes.

Line Feed. That operation which advances the paper under the typebox to enable printing a succeeding line of copy.

Line Feed Clutch. One of six, steel shoe, internal expansion clutches mounted on the main shaft of the printer and used to initiate the action required for the line feed function.

Line Feed Function. This is the mechanical operation of the printer which produces a line feed.

Line Shunt Relay. A relay which when unoperated places a shunt (short circuit) across the signal line. During normal printer operation, this relay is operated and the shunt is removed from the line.

Line Relay. A sensitive polar relay connected in series with the line. Its contacts control the operation of the printer selector magnet.

Line Monitor Relay Group. Those relays which operate to control the send and receive functions in a Teletype system.

Link. A connecting bar or rod, with movable pivots at each end, used to transfer motion.

Linkage. A series or system of links; a series of connecting members for transfer of motion.

Lobe. The high portion of a cam. That portion of a cam which has the greater radius.

Local Loop. A signal line, with its own power source, used for test or transmission within a small area, such as within a building. Sometimes referred to as a dummy line.

Local Operation. The operation of equipment on a local loop.

Lock. A device used to retain or hold a lever or other device in a fixed position until released by an unlocking unit. Similar to a latch.

Lock Washer. A single helical turn of spring tempered steel used beneath a nut or stud head to prevent its loosening.

Lug. An ear-like projection by which an object is held, supported, or contacted by some other object. A formed piece of metal used to connect wires to terminals.

Mainshaft. The shaft which is coupled to the motor and from which the mechanical power is distributed.

Mark Pulse. A binary code pulse obtained by causing the presence of a current in the signal line for a prescribed period of time.

Marking Bias. The tendency of mechanical and/or electrical equipment to produce results that lengthen marking pulses at the expense of the spacing pulses.

Marking Condition. An idle condition of the teletypewriter loop or circuit in which a steady-state marking signal prevents the teletypewriter equipment from "running open" during periods of no traffic.

Marking Contacts. Those relay contacts which are closed when marking current is causing relay operation.

Marking Current. That magnitude and polarity of current in the line when the receiving mechanism is in the operated condition.

MARY Tape. A Baudot code tape punched to repeat the characters "MARY space 4679" for test purposes.

Modulation Rate. The signaling speed of a data stream measured in bauds. It is the number of changes in line condition per second. The reciprocal of the binary digit of smallest duration is the baud.

Neutral Circuit. A teletypewriter operation that uses "current" or "no current" conditions to transmit information. To be contrasted with the "polar circuit."

Nonprint Function. An operation which does not result in a printed character, such as: figures-letters shift, etc. See "Function".

"O" Codebar. One of nine codebars in the printer, it is used in connection with the Automatic Carriage Return and Automatic Line Feed functions and during conditioning operation.

Offline Solenoid. An electrically controlled magnet used to prevent printing.

Open Line. A signal line in which current has stopped for a period equal to or more than the time required to transmit one complete character.

Operation. That process or series of events which results in either the printing of a character or the performance of a function.

Optimum. The best or most desirable condition or degree.

Oscillating Rail. A rail in the printer which moves about two fixed pivot points through a small arc to place the typebox.

Pallet. An extension on a die which, when struck by the printing hammer, will drive the die into an inked

ribbon and apply the impression of the die character to the paper producing a printed character.

Parallel Transmission. Simultaneous transmission of the bits composing a character, either over separate wires or channels, or on different carrier frequencies of the same channel. Contrast with "serial transmission."

Pawl. A mechanical unit which causes advancement of motion of another unit in only one direction. This is done by the pawl pushing, or sometimes pulling, on a tooth of the other unit.

Parity Bit. An extra bit in data signaling indicating either odd or even character or block combinations of binary elements for the purpose of detecting transmission errors.

Perforator. A unit by which signalling code may be punched into a paper tape.

Platen. The hard rubber roller which supports the paper during printing and advances it during line feed.

Polar Circuit. A teletypewriter circuit on which the polarity of applied voltage and resulting direction of current is reversed between marking and spacing impulses.

Polar Differential. A relay having two separate windings and an associated permanent magnet. Either the direction or magnitude of current may be used to cause its operation.

Polar Relay. A teletypewriter line relay capable of high-speed operation and use on both polar and neutral circuits.

Polarential Circuit. A teletypewriter circuit on which a reversal of current is obtained by differences in opposing voltages applied.

Polling. A centrally controlled method of calling a number of points (of a multipoint network) to send information to the central point or to other stations on the network.

Positioning. Operations in the printer which cause movement of the typebox under the hammer so that the proper pallet is struck.

Pulse. A signal having a rise and fall in voltage or current in time, representing one information element.

Rack. A framework or stand used to hold or mount a piece of equipment or machine parts.

Rail. A bar having a smooth surface upon which another component may slide freely.

Red-Black Areas. Designation for classified (red) and unclassified (black) enclosures housing circuits, equipment, or information. The plain text of a classified message is processed in the red area; the secure or encrypted version of that message is processed in the black area of a crypto-center. Restricted access for personnel applies to any red area.

Repel. To push away; to present any opposing force.

Reset. The state of the equipment in an "at rest," "unoperated," or "idle line" condition.

Rest (At). The condition from which mechanical operation begins. Spring action or other mechanical action may cause the parts to assume this condition for each cycle of operation.

RO. Abbreviation for "receive only," as applied to a teletypewriter. It consists only of a hard-copy printer, with no keyboard or paper tape capability.

Rocker. A component which swings back and forth usually less than 180°. One which oscillates.

RT. Abbreviation for "reperforator-transmitter," as applied to a data-handling set used for receive, storage, and send in a message switching center. It consists of a reperforator, large tape reels for storage, and a transmitter distributor. Characters punched into the tape by the reperforator include address information that is read in parallel by the tape reader. The message is punched and stored on reels until the switching processor finds the circuit to the address, connects to it, and signals the transmitter-distributor to start of message.

Running Open. A steady spacing signal on the teletypewriter loop or circuit causing the teletypewriter receiving equipment to cycle continuously without printing characters. An absence of loop current due to line malfunction or other cause.

RY-33. A type of polar relay developed by the Teletype Corporation, widely used in FAA teletypewriter equipment.

Sensing. Mechanically reading to determine which condition exists for each unit of code.

Serial Transmission. Information transfer in which the bits composing a character are transmitted sequentially.

Slide. A bar or flat piece of metal free to be moved within limits, usually in a back and forth manner which affects the operation of associated components.

Slot. An elongated cut; an opening which permits only lengthwise motion of a post or stud extending into it.

Soft Copy. A temporary (volatile) printout of a data-handling terminal, for example, on a cathode-ray-tube (CRT) display.

Space. A no-signal pulse on the line. The movement of the type box the width of a character without printing taking place.

Spring. A device used to exert a restoring force. It may be almost any shape, but it is usually flat or helical like a coil of wire. It is usually made of spring steel or brass.

Spur Gear. A gear having teeth parallel to the axis of rotation of the shaft or axle.

Stop. Mechanical obstruction to prevent further motion of some component.

Stop Pulse. A continuous current on the line, lasting any length of time until a start (no current) pulse is sent.

Stud. A machine screw or bolt which fits into threads in some component. A nut is not used. Studs frequently have an unthreaded, smooth area between the bottom of the head and the threads.

Stunt Box. The function and selector mechanism of a teletypewriter set. It actuates the receiver portion of the set when matching selective calling codes are received. It also suppresses locally non-printing functions such as figures/letters shift, line feed, carriage return, and the like.

Synchronous System. A system in which the transmitting and receiving modems are operating at essentially the same frequency. Their synchronism is maintained by phase correction or pattern detection circuitry.

Tape. A specially prepared paper strip (usually 7/16" wide) which may be perforated with coded representations of various characters. It is used in a transmitter distributor to transmit a message.

Telegraph. Originally a term for Morse code communication, it represents any direct-current signaling with closed (current) and open-circuit (no current) conditions representing binary mark and space elements.

Tempest. A short name for the study or investigation of compromising emanations (e.g., in cryptosystems (COMSEC)).

Tension. The force exerted by a spring or other elastic medium.

Terminal. The end of a wire or winding or a contact, whether a solder lug or a screw connection, to which connections are made to some external circuit.

Thermal Cutout. A thermal (heat) operated switch that will open an electrical circuit when excessive current flows through the switch and/or when the equipment exceeds safe operating temperature. (See Klixon.)

Tine. The protruding finger-like portion of the function bar that senses the position of the rear (notched) portion of the code bars.

Torn-Tape System. An older manual message routing system in which teletypewriter messages were relayed by reperfornated paper tape handcarried from the receiver - the reperforator of an incoming tributary - to the transmitter distributor of an outgoing tributary.

Track (or Rail). A smooth edge-like surface over which slides or carriage rollers are to travel.

Transfer Lever. That lever which positions the six code bar shift bars of an M-28 Teletype printer.

Transition. The change in current from one steady state or condition to another steady state or condition.

Transit Time. Time required for a transition.

Transmitter Distributor (TD). This is a device used to transmit a torn-tape or locally-prepared tape message.

Trip Lever. A lever which will cause some latch or catch to be released.

Type. The casting (die) for a letter, character, or figure that, when pressed against an inked ribbon onto a paper, will leave an impression upon the paper.

Type Box. The holder for the type pallets in a tele-typewriter machine.

Type Pallets. A short metal bar which is the mounting for a type casting (die). It is mounted, along with a compression spring, in a type box.

Typewriter. The complete printer equipment that transcribes a telegraph message that has been received in proper form.

Typing Unit. The unit which does the actual printing, including the type box, codebars, and similar components which may all be removed as a single assembly.

Unselected. The state or condition of those levers and/or bars which are in a space position when a character has been read into the printer mechanism.

Unshift. The repositioning of the printer mechanism from figures to letters category.

Upper Horizontal Motion Stop Slide. A part of the mechanism which is connected to the number four code bar which, when in the space position, will stop the oscillating rail shift slide in the second column to the right or left of a category center line.

Vertical Positioning. The sequence of actions involved in positioning of the type box to select printing in one of the four horizontal rows of the type box.

Winding. A coil of wire arranged to form an electromagnet when an electric current is in the winding.

Wire Rope. A rope, sometimes small enough to be termed twine or cord, made of twisted wires.



APPENDIX 2. M28 TELETYPEWRITER DRAWING INDEX

<i>Revision No.</i>	<i>Drawing Number</i>	<i>Drawing Title</i>
	IMB-B-544/-1	LAX6XL KEYBOARD
10	IMD-D-361	RO/KSR WIRING SCHEMATIC
7	IMD-D-439	ASR WIRING SCHEMATIC
4	FAAD-D-114	RO/KSR ACTUAL WIRING
4	IMD-E-533	ASR ACTUAL WIRING
4	IMD-E-547	ASR, LAK 28/LPR50 ACTUAL WIRING
1	FAAD-D-123	ASR, LBXD4, ACTUAL WIRING AND SCHEMATIC
B	DE-D-123	STACKED PRINTER LBAC-235-FAA SCHEMATIC
REV A	DE-D-1200-1	STACKED PRINTER LBAC-235 FAA ACTUAL
REV A	DE-D-1200-2	STACKED PRINTER LBAC-235 FAA ACTUAL
REV A	DE-D-1200-3	STACKED PRINTER LBAC-235 FAA ACTUAL
2	FAAD-D-391-1	LBXD4 OR M14TD IN AC273 ABBREVIATED SCHEMATIC
	IMD-C-496	DUCT ACCESS MOD FOR M28 ASR CABINET
	FAAD-D-397	TTY LINE TEST METER & TEST LOOP POWER SUPPLY
	FAAD-D-393-1	TTY LINE SWITCHING TERMINAL INST'L BARRIER STRIP OPTION
	FAAD-D-296-3A	LSU CONTROL CIRCUIT INTERCONNECTIONS (ASR, RO & TANDEM TD SET)
	FAAD-D-296-3B	(ASR & ASR WITH REPERFORATOR)
	FAAD-D-296-3C	(RT SETS)
	FAAD-D-398-1	TTY LINE SWITCHING TERMINAL INST'L INTER CONNECTION DIRECT WIRING OPTION

APPENDIX 2. M28 TELETYPEWRITER DRAWING INDEX (continued)

<i>Revision No.</i>	<i>Drawing Number</i>	<i>Drawing Title</i>
REV D	FAAD-D-398-2	TTY LINE SWITCHING TERMINAL INST'L INTER CONNECTION DIRECT WIRING OPTION
	DR-D-40052-1	MODEL 14XD ARRANGED FOR AUTOMATIC SERVICE
	FAAD-D-413	M28 REPERFORATOR-TRANSMITTER SET SCHEMATIC DIAGRAM
	DE-E-236-5	FAA LOW LEVEL KEYING MODIFICATION ASR CABINET SCHEMATIC
	DE-D-236-6	FAA LOW LEVEL KEYING MODIFICATION ASR CABINET WIRING
	DE-D-236-7	FAA LOW LEVEL KEYING MODIFICATION KSR/RO CABINET SCHEMATIC
	DE-D-236-8	FAA LOW LEVEL KEYING MODIFICATION KSR/RO WIRING
	DE-C-236-9	FAA LOW LEVEL KEYING MODIFICATION ASR-KSR-RO KEYBOARD-BASE SCHEMATICS
	DE-C-236-12	FAA LOW LEVEL KEYING MODIFICATION ASR SET TEST FIXTURE
	DE-E-236A-5	FAA LOW LEVEL KEYING MODIFICATION ASR CABINET SCHEMATIC (PONY CIRCUIT)
	DE-D-236A-6	FAA LOW LEVEL KEYING MODIFICATION ASR CABINET WIRING (PONY CIRCUIT)
	DE-D-236-13	FAA LEVEL KEYING MODIFICATION ASR-SET TEST FIXTURE-PONY CIRCUIT ADAPTOR
	FMD-D-421	ED 200 AD/CA-406
	DE-D-208	TLTP LINE TEST SET
	DE-E-1200	FAA STD M28 STACKED PRINTER SET, LBAC-235 WIRING
	DE-D-1185	FAA STD M28 STACKED PRINTER SET, LBAC-235 WIRING

APPENDIX 2. M28 TELETYPEWRITER DRAWING INDEX (Continued)

<i>Revision No.</i>	<i>Drawing Number</i>	<i>Drawing Title</i>
	DE-D-901	FA-8705 LINE SWITCHING UNIT, (MECH)
	DE-D-902	FA-8705/1 LSU (SCHEM)
	DE-D-903	FA-8705/2 LSU (SCHEM)
	DE-D-904	FA-8705/3 LSU (SCHEM)
	DE-B-923	FA-8705/1 MECH EXT ADAPTER



APPENDIX 3. M35 TELETYPEWRITER DRAWING INDEX

<i>Drawing Number</i>	<i>Drawing Title</i>
2900WD	Motor, LMU3
4348WD	Transmitter Base, LCXB806
5814WD	Transmitter Distributor, LXD804
5983WD	Selector Magnet Driver, 193485
5984WD	Typing Reperforator, LPR805
6043WD	Typing Unit (Friction Feed), LP813
6380WD	Power Panel Assembly, 199327
6384WD	ASR-35 Set
6394WD	Electrical Service Unit, LESU313
6395WD	Keyboard, LAK806
6903WD	Mode Switch Assembly, 198242
7584WD	Copyright Bracket Assembly, 199347
7890WD	Selector Magnet Driver Circuit, 182630, - 35
182630-35	Selector Magnet Driver



**APPENDIX 4. TELETYPE CORPORATION M28, M35, AND
M37 EQUIPMENT NOMENCLATURES,
BULLETIN SECTIONS, AND NSN'S**

Section 1. M28 EQUIPMENT

<i>Apparatus Code</i>	<i>Usage</i>	<i>M28 9-Digit Section No.</i>	<i>M28 National Stock No.</i>
LP	D	573-115-100	0056-00-321-7000
	A	573-115-700	0056-00-321-8000
	L	573-115-701	0056-00-321-9000
	D&R	573-115-702	0056-00-322-0000
	P	573-115-800	0056-00-315-6000
LB,LK	D	573-116-100	0056-00-322-1000
	A	573-116-700	0056-00-322-2000
	L	573-116-701	0056-00-322-3000
	D&R	573-116-702	0056-00-322-4000
	P	573-116-800	0056-00-319-6000
LESU	D	573-133-100	0056-00-325-3000
	A	573-133-700	0056-00-325-4000
	L	573-133-701	0056-00-325-5000
	D&R	573-133-702	0056-00-325-6000
	P	573-133-800	0056-00-320-4000
	P	573-133-804	0056-00-320-5000
LAC,LBAC, LPC	D	573-134-100	0056-00-325-8000
	A	573-134-700	0056-00-325-9000
	L	573-134-701	0056-00-326-0000
	D&R	573-134-702	0056-00-326-1000
LAC	P	573-134-800	0056-00-315-7000
LPC	P	573-134-801	0056-00-320-6000
	P	573-134-804	0056-00-320-7000
LBAC(PTR)	P	573-136-803	0056-00-319-7000
LAK	D	573-117-110	0056-00-316-9000
	A	573-117-700	0056-00-322-5000
	L	573-117-701	0056-00-322-6000
	D&R	573-117-702	0056-00-322-7000
	P	573-117-800	0056-00-315-9000
LPE,LTPE	D	573-139-100	0056-00-317-3000
	A	573-139-700	0056-00-320-1000
	L	573-139-701	0056-00-327-3000
	D&R	573-139-702	0056-00-327-4000
	P	573-139-800	0056-00-315-8000

<i>Apparatus Code</i>	<i>Usage</i>	<i>M28 9-Digit Section No.</i>	<i>M28 National Stock No.</i>
LPR	D	573-118-100	0056-00-322-8000
	A	573-118-700	0056-00-318-7000
	L	573-118-701	0056-00-318-8000
	D&R	573-118-702	0056-00-318-9000
	P	573-118-800	0056-00-322-9000
LRPE	P	573-119-800	0056-00-323-0000
LCXB	D	573-128-100	0056-00-317-1000
	P	573-128-800	0056-00-316-0000
LXD	D	573-127-101	0056-00-323-7000
	A	573-127-703	0056-00-324-1000
	L	573-127-704	0056-00-324-2000
	D&R	573-127-705	0056-00-324-3000
	P	573-127-801	0056-00-324-4000
LAXD, LCXD	A	573-127-700	0056-00-323-8000
	L	573-127-701	0056-00-323-9000
	D&R	573-127-702	0056-00-324-0000
LAXD	P	573-127-800	0056-00-280-4000
LCXD	P	573-127-803	0056-00-230-5000
LBXD	A	573-127-706	0056-00-317-4000
	L	573-127-707	0056-00-317-5000
	D&R	573-127-708	0056-00-317-6000
	P	573-127-802	0056-00-317-4000
LMU	D	570-220-100	0056-00-318-3000
	A	570-220-700	0056-00-318-4000
	L	570-220-701	0056-00-318-5000
	D&R	570-220-702	0056-00-340-0000
	P	570-220-800	0056-00-318-6000
LAAC	D	573-134-101	0056-00-317-2000
	A	573-134-703	0056-00-326-2000
	L	573-134-704	0056-00-326-3000
	D&R	573-134-705	0056-00-326-4000
	P	573-134-802	0056-00-316-2000
ASR	D	573-101-100	0056-00-316-8000
	OT	573-101-500	0056-00-319-9000
	D&R	573-101-702	0056-00-320-0000
KSR&RO	D	573-100-100	0056-00-014-7003
	OT	573-100-500	0056-00-321-1000
	D&R	573-100-702	0056-00-321-2000

<i>Apparatus Code</i>	<i>Usage</i>	<i>M28 9-Digit Section No.</i>	<i>M28 National Stock No.</i>
RT SETS	A	573-104-700	0056-00-318-0000
LRXB	L	573-104-701	0056-00-318-1000
LTHS	D&R	573-104-702	0056-00-318-2000
LRXB	P	573-125-800	0056-00-323-5000
LTHS	P	573-125-801	0056-00-323-6000
LBAC(R/T)	P	573-136-802	0056-00-327-1000

Section 2. M35 EQUIPMENT

<i>Apparatus Code</i>	<i>Usage</i>	<i>M35 9-Digit Section No.</i>	<i>M35 National Stock No.</i>
LP	D&O	574-220-100	0056-00-356-2000 (Vol. 1)
	A	574-220-700TC	0056-00-356-2000
	L	574-220-701	0056-00-356-2000
	D&R	574-220-702	0056-00-356-2000
LESU	D&O	574-226-100	0056-00-356-2000 (Vol. 1)
LPR	D&O	574-233-100	0056-00-356-3000 (Vol. 2)
	A	574-233-700TC	0056-00-356-3000
	L	574-233-701	056-00-356-3000
	D&R	574-233-702	0056-00-356-3000
LCXB	D&O	574-223-100	0056-00-356-2000 (Vol. 2)
	A,L	574-223-700	0056-00-356-2000
LXD	D&O	574-225-100	0056-00-356-2000 (Vol. 2)
	A	574-225-700TC	0056-00-356-2000
	L	574-225-701	0056-00-356-2000
	D&R	574-225-702	0056-00-356-2000
LAAC	D&O	574-228-100	0056-00-356-2000 (Vol. 2)
	A	574-228-700TC	0056-00-356-2000
	L	574-228-701	0056-00-356-2000
LMU	D&PO	570-220-100TC	0056-00-356-3000 (Vol. 3)
	A	570-220-700TC	0056-00-356-3000
	L	570-220-701TC	0056-00-356-3000
ASR	D&O	574-202-200	0056-00-356-2000 (Vol. 1)
LAK	D&O	574-222-100	0056-00-356-2000 (Vol. 1)
	A	574-222-700TC	0056-00-356-2000
	L	574-222-701	0056-00-356-2000
	D&R	574-222-702	0056-00-356-2000

NOTE: M35 sections are identified by the NSN applicable to the FA-7938 instruction book, Volume 1 or Volume 2, as shown in the above column.

Section 3. M37 EQUIPMENT

<i>Apparatus Code</i>	<i>Usage</i>	<i>9-Digit Section No.</i>	<i>National Stock No.</i>
RO	D&O	574-300-103TC	0056-00-343-4000
	I	574-300-200TC	0056-00-343-5000
ASR	D&O	574-302-100TC	0056-00-344-1000
	I	574-302-200TC	0056-00-344-2000
	TS	574-320-300TC	0056-00-344-3000
YP	D&PO	574-320-101TC	0056-00-344-5000
	A	574-320-703TC	0056-00-344-6000
	L	574-320-704TC	0056-00-344-7000
	D&R	574-320-705TC	0056-00-344-8000
	P	574-320-801TC	0056-00-344-9000
YK,YB	D&PO	574-321-101TC	0056-00-345-0000
	A	574-321-703TC	0056-00-345-1000
	L	574-321-704TC	0056-00-345-2000
	D&R	574-321-705TC	0056-00-345-3000
	P	574-321-801TC	0056-00-345-4000
YESU	D&O	574-322-101TC	0056-00-345-5000
	P	574-322-801TC	0056-00-345-6000
YAB	D&PO	574-325-100TC	0056-00-346-1000
YRPE	D&PO	574-329-100TC	0056-00-347-6000
	A	574-329-700TC	0056-00-347-7000
	L	574-329-701TC	0056-00-347-8000
	D&R	574-329-702TC	0056-00-347-9000
	P	574-329-800TC	0056-00-348-0000
YPR	D&PO	574-330-100TC	0056-00-348-1000
	A	574-330-700TC	0056-00-348-2000
	L	574-330-701TC	0056-00-348-3000
	D&R	574-330-702TC	0056-00-348-4000
	P	574-330-800TC	0056-00-348-5000
YMU	See M35 listing.		



Slot	Function Bar	Function Lever	Function Pawl	Spring Plate	Switch & Slide	Function Bar	Switch Wired To	APPLICATION	REQUIRED AT				
									Weather Bureau	ARTCC FLIDAP	L.S. RLA SVC "B"	SVC "A" "B" & "C" FST & FSS	
1	152675	152641	152653	152660		LC-RL		Suppresses Space On Blank					
2	152666	152641	152653	152660	○	FIGS		Figures Shift					
3	152665	152641	152653	152660	○	LTRS		Letters Shift					
4	152671	152641	152653	152660		CR-LF		Automatic Carriage Return					
5	152667	152641	152653	152660		CR		Carriage Return					
6	152668	152121	152653	154613		LF		Sequential Selection Slot 7 ON LF	} END OF MESSAGE CODE	For Unlock	For Unlock	For Unlock	For Unlock
7	152667	152121	152653	154613		CR		Sequential Selection Slot 8 ON LF, CR					
8	152665	152298	152653	154613	□	LTRS	Y-5	Open N.C. Contacts On LF, CR, LTRS	} T.D. CONTROL	For Unlock	For Unlock	For Unlock	For Unlock
9		152121	152653	154613		SC #		Sequential Selection Slot 10 On 1st Letter of Call					
10		152298	152653	154613	■	#	Y-5 & Y-16	Close Contacts On 1st + 2nd Letter of Call	} CONDITION CODES	For Unlock	For Unlock	For Unlock	For Unlock
11	152668	152642	153604	152660		LF		Sequential Selection Slot 13 On LF					
12	152667	152121	153598	154613		CR		Sequential Selection Slot 13 On CR					
13	152667	152121	152653	154613		CR		Sequential Selection Slot 14 On LF, CR or CR, CR					
14	152665	152298	152653	154613	○	LTRS		Move O Code Bar On LF, CR, LTRS or CR, CR, LTRS					
15	152689	152121	152653	154613		N		Sequential Selection Slot 16 On 1st N					
16	152689	152121	152653	154613		N		Sequential Selection Slot 17 on 1st - 2nd N					
17	152689	152121	152653	154613		N		Sequential Selection Slot 18 on 1st + 2nd + 3rd N					
18	152689	152298	152653	154613	□	N	Y-15	Open N.C. Contacts On N-N+N-N	} SPECIAL	For Unlock	For Unlock	For Unlock	For Unlock
19	153432	152121	152653	154613		SC X		Sequential Selection Slot 20 On 1st Letter of Call					
20	152701	152298	152653	154613	■	X	Y-5 & Y-18	Close Contacts On X+X	} SELECT CODES	For Unlock	For Unlock	For Unlock	For Unlock
21	**	152121	152653	154613		SC #		Sequential Selection Slot 22 On 1st Letter of Call					
22	**	152121	152653	154613		#		Sequential Selection Slot 23 On 1st + 2nd Ltr of Call					
23	**	152298	152653	154613	■	#	Y-5 & Y-18	Close Contacts On 1st + 2nd + 3rd Ltr of Call					
24	**	152121	152653	154613	□	SC #		Sequential Selection Slot 25 On 1st Ltr of Call					
25	**	152121	152653	154613	□	#		Sequential Selection Slot 26 On 1st + 2nd Ltr of Call					
26	**	152298	152653	154613	□	#		Close Contacts On 1st + 2nd + 3rd Ltr of Call					
27						SC #		Sequential Selection Slot 28 On	} SPECIAL RELAY CALL	For Unlock	For Unlock	For Unlock	For Unlock
28						#		Sequential Selection Slot 29 On					
29						#		Sequential Selection Slot 30 On					
30					□	#	Y-5 & Y-8	Close Contacts On	} UNBLIND REPERFORATOR & PRINT	For Unlock	For Unlock	For Unlock	For Unlock
31	*	152121	152653	154613		SC #()		Sequential Selection Slot 32 On 1st Letter of Call					
32	*	152121	152653	154613	□	#()		Sequential Selection Slot 33 On 2nd Letter of Call					
33	*	152298	152653	154613	■	#()	Y-5 & Y-19	Close Contacts On 3rd Letter of Call	} Printer And TD Call	For Unlock	For Unlock	For Unlock	For Unlock
34						#()							
35		152121	152653	154613					} Cat	For Unlock	For Unlock	For Unlock	For Unlock
36		152121	152653	154613									
37		152121	152653	154613					} TD	For Unlock	For Unlock	For Unlock	For Unlock
38		152298	152653	154613	□								
39	152671	152642	153598	152660		CR-LF		Automatic Line Feed	} BELL	For Unlock	For Unlock	For Unlock	For Unlock
40	153435	152641	152653	152660		SC-LF		Line Feed					
41	153437	152641	152653	152660	■	SC-UC S	Y-2 & Y-7	Signal Bell	} BELL	For Unlock	For Unlock	For Unlock	For Unlock
42	152668	152641	152653	152660		LF		Suppresses Space On Single Line Feed					

Use 4703 Function Bar Springs, 157240 Function Pawl Springs with 72522 Oilers, 90517 Function Lever Springs, 172525 Switch Assemblies.

- * = Call Letter, Function Bar as Required
- ** = Area Call Letter, See Bulletin 11498 For Part Number
- = Mechanical Linkage To Perform Function
- = Normally Closed Contacts Used
- = Normally Open Contacts Used
- LC = Lower Case
- UC = Upper Case
- SC = Stunt Case (special six-tined letter function bar required). Where SC is used, Condition Code must precede sequential Select Code
- T.D. = Transmitter Distributor
- FLIDAP = Flight Data Position
- L.S. RLA = Low Speed (100 wpm) Relay
- # = Call Letter As Required
- CAT = Clear Air Turbulence Reports



U.S. Department
of Transportation
**Federal Aviation
Administration**

Memorandum

Subject: INFORMATION: Suggested improvements to
Order 6170.6A, Maintenance of Data-Handling
Terminal Equipment (Teletypewriter)

Date:

From: _____
Signature and Title

Reply to
Attn. of:

Facility Identifier
AF Address

To: Manager, National Engineering
Field Support Division, ASM-600

Problems with present handbook.

Recommended improvements.