

INSTRUCTIONS FOR INSTALLING THE MODEL 28 WALL MOUNTED PAGE PRINTER SET

1. GENERAL

a. This specification covers the installation of the Model 28 Wall Mounted Page Printer Set.

b. Additional information on the units which make up the Set will be found in the following bulletins:

- 216B - Description and Theory of
Operation - Model 28 Printer
- 217B - Adjustments and Lubrication - LP, LK, LB, LAC, LPC
- 1149B - Parts - Model 28 Page Printer Set

NOTE

For Bell System only - See appropriate sectionalized information.

c. References made to left or right, up or down, and front or rear apply to the equipment in its normal operating position as viewed from the front.

2. COMPONENTS

a. The Model 28 Wall Mounted Page Printer Set consists of the following basic units:

- (1) Back Plate Assembly - (Part of LPC)
- (2) Intermediate Gear
- (3) Keyboard or Base - LK, LB
- (4) Page Typing Unit-LP
- (5) Electrical Service Unit - LESU
- (6) Cover - LPC

These are basic units some of which may be provided with various accessories for different service requirements. The above units are listed in their order of installation. The base unit is used with the Receive Only (RO) Set; the keyboard unit is used with the keyboard Send Receive (KSR) Set. The intermediate gear (Item 2 above) must be ordered separately for the desired operating speed (60, 75, or 100 words per minute).

b. The double asterisks (**) designates a two letter (Bell System two-digit) suffix which denotes paint finish.

3. UNPACKING UNITS

Unpack all units with care, observing all caution labels and instructions. All bags and small loose parts should be kept with their associated apparatus until installation.

4. MOUNTING BACK PLATE ASSEMBLY

a. The fully assembled Wall Mounted Page Printer Set weighs approximately 110 pounds and has seven mounting holes for attachment to the wall. The supporting wall must be able to withstand a 60-pound shear force and a 90-pound tensile (or compressive) force at each mounting hole.

b. The locations of the mounting holes on the back plate assembly are shown in Figure 1. Since the horizontal distance between holes is 14-5/8 inches, the back plate cannot be mounted on standard 16 inch center-to-center wall studs. When attaching the back plate assembly to wall structures where the existing mounting holes are unsatisfactory, alternate holes may be added along the side and bottom edges. No mounting hardware can be located along the upper central edge since the existence of such hardware would interfere with the paper supply.

c. The following list contains suggested mounting hardware to be used with various wall materials.

(1) Masonry Wall - Use Ackerman-Johnson retainers or tabular expansion shields (made by the Rawplug Company) with 3/16 inch diameter or #12 bolts.

(2) Hollow Wood or Tile Wall - Use 3/16 inch diameter toggle bolts.

(3) Solid Wood Wall - Use #12 round head wood screws.

(4) Lath and Plaster or Plasterboard Walls - Use 3/16 inch diameter toggle bolts. Auxiliary support may be required for these types of walls. Caution must be taken to insure that the supporting wall meets the loading requirements set forth in Paragraph 4.a.

d. As indicated in Figure 1, the recommended height from the floor to the top mounting holes is 54 inches. This distance has been found satisfactory to accommodate an average height operator. If desired, the height may be varied to meet the customer's requirements.

e. If the back plate is used for locating the mounting holes on the wall, it may be more convenient to separate the framework from the back plate. This can be accomplished by loosening the four screws shown in Figure 2 and sliding the framework from the back plate assembly.

5. SUBASSEMBLY OF COMPONENTS

a. The following assembly and adjustments, pertinent to the keyboard (or base) and the typing unit, are to be performed before the units are installed on the back plate assembly. The purpose is to install and adjust the intermediate gear and adjust the timing belt connecting the intermediate gear assembly and motor pulleys.

b. ADDITION OF INTERMEDIATE GEAR TO KEYBOARD (OR BASE) - SEE FIGURE 3.

Remove the retainer ring which is adjacent to the left bearing side and the 3/8 inch hex-nut and associated lockwasher from the right end of the shaft. Slide the shaft to the left and remove the pulley, the two belt retainers, and the belt. Place the rubber isolator over the small end of the intermediate gear. Slide the gear with isolator onto the shaft so that the isolator side is on the left. Replace the two belt retainers, the belt and the pulley. Then slide the shaft to the right back to its original position and replace the retainer ring and the 3/8 inch hex nut and associated lockwasher. Locate the intermediate gear in its correct position and fasten it with the two set screws supplied.

c. MOUNTING TYPING UNIT ON KEYBOARD (OR BASE)

CAUTION

Loosen mounting screws on the intermediate gear assembly and move it to its rearmost position.

Remove and retain the four mounting screws supplied with the base unit. (See Figure 3). Place the typing unit on the keyboard (or base) unit and make certain that the front feet of the typing unit are placed over the locating studs provided on the base unit. Rotate the intermediate shaft by hand in order to mesh the gear teeth. Secure the typing unit to the base unit with the four mounting screws.

d. INTERMEDIATE GEAR AND TIMING BELT ADJUSTMENTS

(1) Adjust the intermediate gear assembly and the timing belt as indicated in Figures 4 and 5.

(2) Remove the typing unit from the keyboard (or base) in preparation for installing the keyboard (or base) on the back plate assembly.

6. MOUNTING KEYBOARD (OR BASE) TO WALL MOUNTED BACK PLATE ASSEMBLY

a. Insert the keyboard ground strap between the mounting stud and isomode plate located in the front right corner.

b. With the motor unit in its properly adjusted position and the typing unit removed from the base, secure the keyboard (or base) to the back plate assembly with the mounting studs which are supplied as part of the keyboard (or base) assembly.

7. MOUNTING TYPING UNIT TO KEYBOARD (OR BASE)

a. See Paragraph 5.c. for instructions. Neglect the caution note for this assembly.

b. With the keyboard (or base) and typing unit in place, adjust the two support hinges near the base of the back plate assembly as indicated in Figure 6.

8. MOUNTING AND CONNECTING THE ELECTRICAL SERVICE UNIT

a. The lower part of the mounting frame has four projecting tabs upon which the electrical service unit rests (see Figure 2); place the service unit into the frame. The hinged front plate is held in place by a magnetic latch on the mounting frame. The plate and latch should be perpendicular to each other as gauged by eye. If necessary, loosen the screws and position the latch to meet the requirement.

b. Route the keyboard connecting cable up along the left side of the mounting frame. Route the cable behind all spring clips supplied with the mounting frame for this purpose. Clamp the keyboard cable to the keyboard with the spring clip supplied on the keyboard. (See Figure 3). Route the typing unit connector up along the right side of the mounting frame and fasten with the spring clips supplied with the frame.

c. Connect the two ground straps at the left end of the service unit to the cabinet mounting frame and the page printer mounting frame, securely. See Figure 7. The screws chosen to make the ground connection must go into tapped holes in both of the mounting frames to insure a sufficient ground.

NOTE

Ground connections must be made properly to eliminate shock hazard!

9. COVER ADJUSTMENTS AND INSTALLATION

a. With the cover removed from the back plate assembly, perform the cover hinge, latch, and copyholder adjustments given in Figure 8.

b. Before placing the cover on the back plate assembly, loosen the nut securing the large central mount and make it friction tight. The mount is illustrated in Figure 10. For Receive Only (RO) Sets, remove the three keylever assemblies from the cover by removing six nuts, lockwashers and flat washers.

NOTE

The following adjustments are to be performed with the cover in place but not secured, i.e., the two screws at the bottom of the back plate assembly are not tightened.

c. SEND RECEIVE HOOD AND COVER ADJUSTMENTS

Adjust the hood and cover as shown in Figures 9 and 10. The mounting bar is moved up or down to increase or decrease the gap between the keyboard hood and keytop guide plate; and the keyboard is moved in or out to decrease or increase the gap between the keytop guide plate and the cover lip.

d. RECEIVE ONLY COVER, POWER SWITCH, AND KEYLEVER ADJUSTMENTS

Adjust the cover, power switch, and keylever assemblies as shown in Figures 11, 12 and 13. The cover is moved up or down to vary the upper and lower gap between the power switch and the cover. The deflected power switch is made flush with the cover by either a local adjustment of the base front plate or by moving the base in or out. The keylever assemblies are adjusted by moving the keylever adjustment screw in or out.

e. GENERAL COVER ADJUSTMENTS

Adjust the paper guide and window as shown in Figure 14.

f. Upon completion of the above adjustment, secure the cover in position with the two screws located near the bottom of the back plate assembly.

g. Clip the lamp shields on the two copylight lampholders. The clearance between the lamp shields and the cover should be a minimum of 1/16 inches. If an adjustment is required, bend the support brackets.

10. POWER AND TELEGRAPH CONNECTIONS

a. The power cord to be used with the apparatus must be of the three-wire type. A twist lock receptacle supplied with the electrical service unit is to be connected to the mate provided on the bottom plate of the service unit.

NOTE

Attach the ground lead to the center post of the twist lock receptacle.

b. Power and telegraph leads may be brought through the rear of the back plate assembly or through the hole located in the bottom of the cover.

11. INSTALL PAPER AND RIBBON

a. The paper spindle for the friction feed page printer is supplied with the typing unit. Insert the spindle in a roll of paper and mount it in the lower part of the cabinet such that the paper unwinds from underneath. Route the paper up through the paper channel in the rear and down under the platen as shown in Figure 15. Check power lead and, if necessary, route it in such a manner as not to interfere with the paper.

b. If a sprocket feed page printer is installed, the bakelite spindle retainers may be removed to provide additional storage space for sprocket feed forms. These retainers are attached to the lower part of the back plate assembly.

c. Remove both spools from the ribbon spool shafts. Engage the hook on the end of the new ribbon in the hub of the empty spool. Wind a few turns of the ribbon onto the empty spool in the same direction that it comes off the full spool. Make sure that the reversing eyelet has been wound up on the empty spool. Place the spools on the spool shafts so that the ribbon on the right spool comes off the right side and the ribbon on the left spool comes off the left side without twisting. Thread the ribbon around the rollers and through the reverse lever slots. See Figure 16.

12. OPERATING TESTS

a. Type several lines of a sentence such as "The quick brown fox, etc." and check for accuracy.

b. The local line feed key (LOC LF), when depressed, should cause the paper to be fed out of the machine approximately three times faster than when the line feed key is repeatedly operated.

c. The keyboard lock key (KBD LOCK), when depressed, should prevent operation of any other key except the local line feed, keyboard unlock and local carriage return keys. It should remain depressed until released by the keyboard unlock key.

d. The keyboard unlock key (KBD UNLK), when depressed, should unlock the keyboard. The break key, when depressed, should hold the transmitting line open. If the duration of the open-line interval is greater than two character cycles, the keyboard lock should operate.

e. The repeat key (REPT), when depressed together with any other key lever except the local keys, should cause repeated transmission of the signal.

f. The local carriage return key (LOC CR), when depressed, should cause the carriage to return.

g. With the type box in figures position, the bell should ring clearly on single or repeated operations of the Bell Key.

h. Determine that the operation of the FIGS key conditions the machine for the typing of upper case characters, and that the operation of the LTRS key conditions it for the typing of lower case characters.

*

*

*

(50170S)

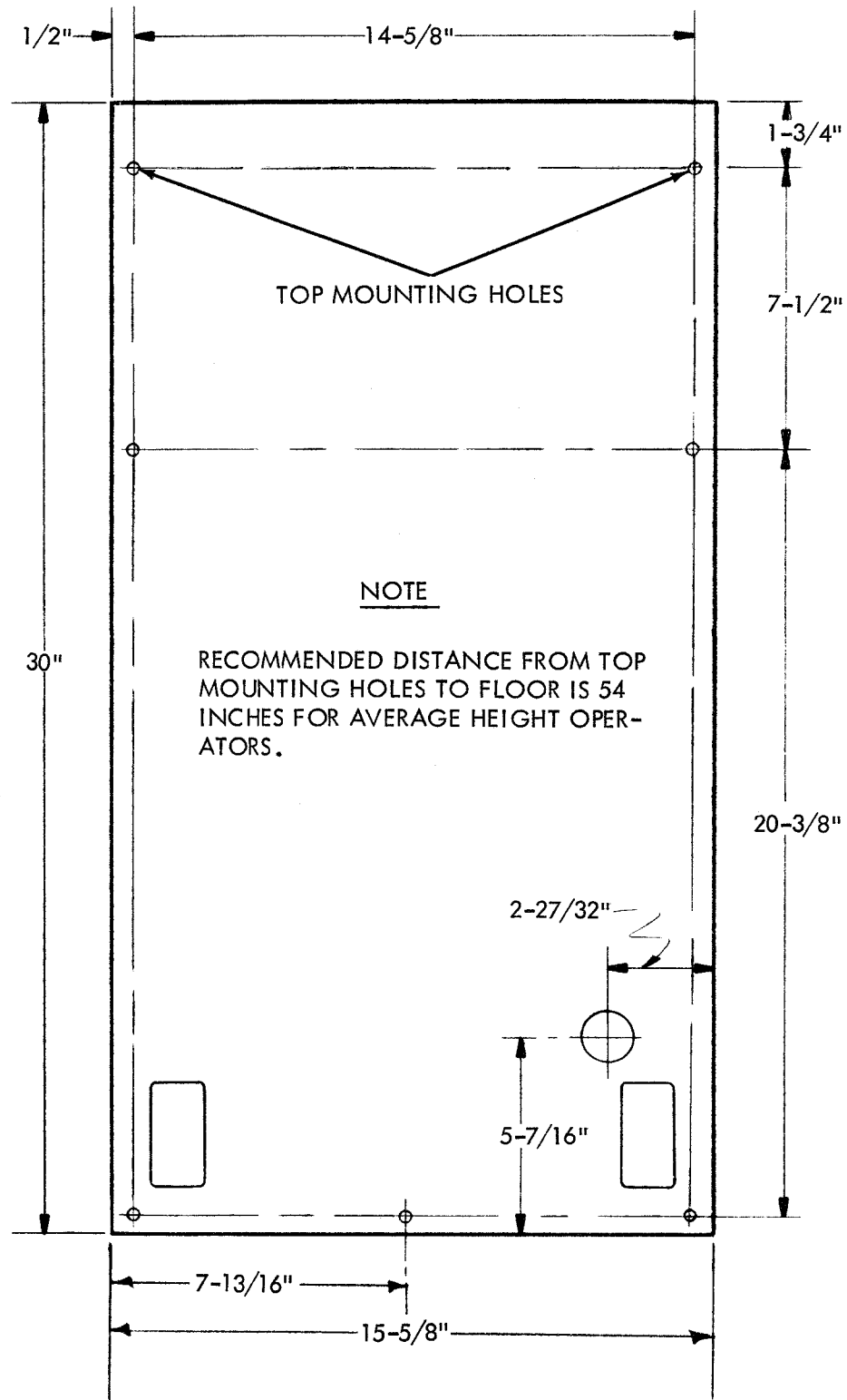

Figure 1 - Location of Mounting Holes for Back Plate

(50170S)

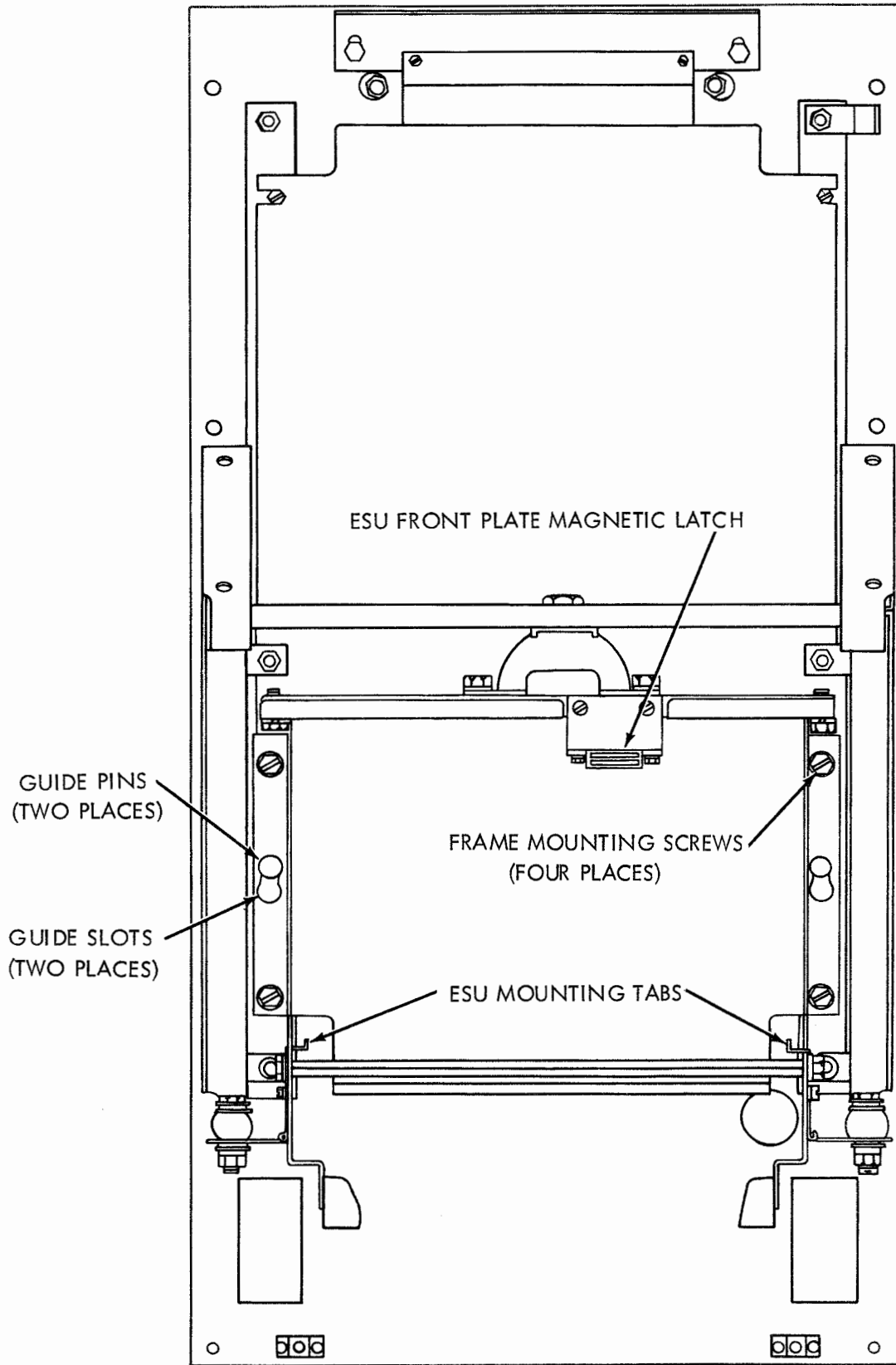

Figure 2 - Framework Mounted on Back Plate

(50170S)

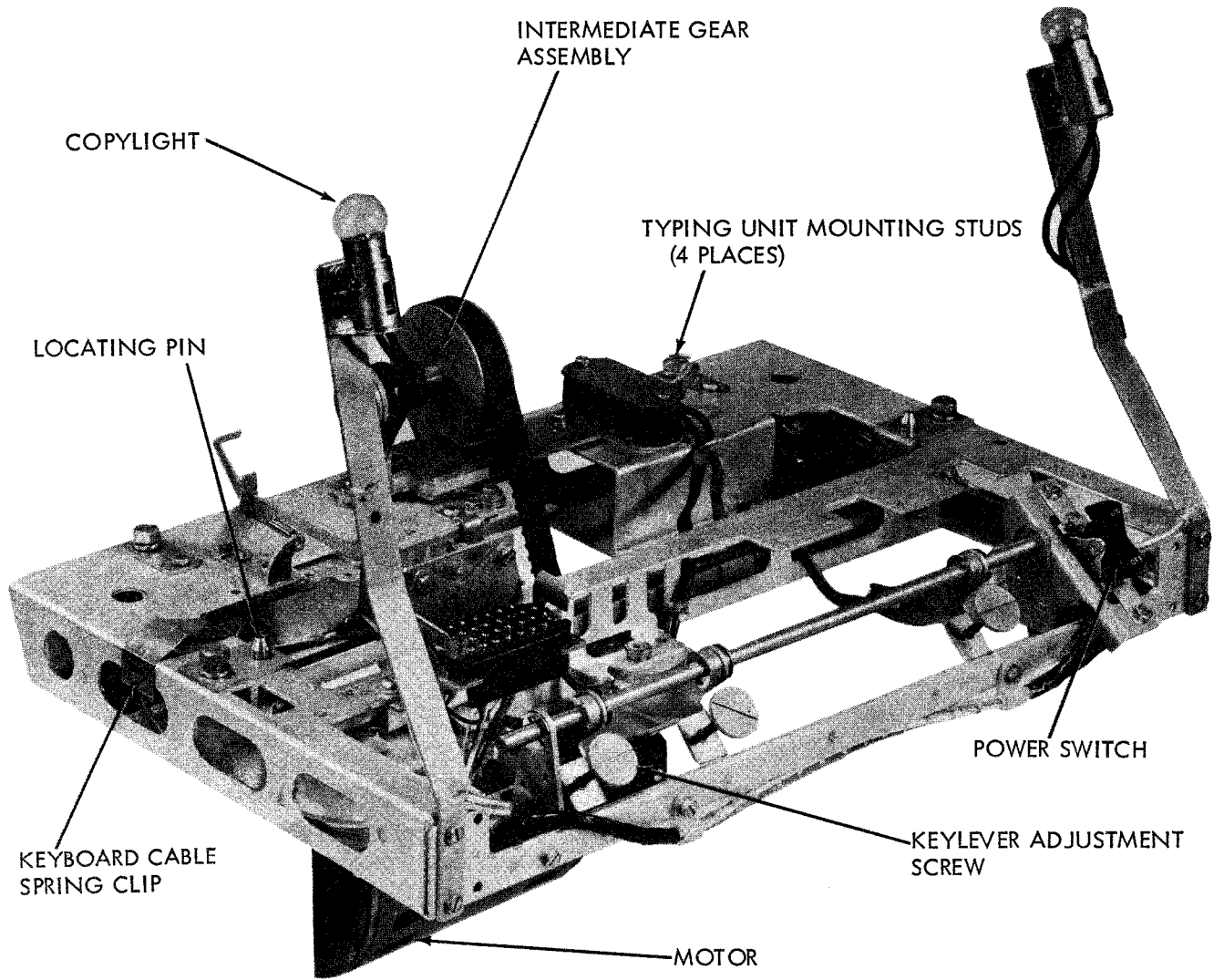

Figure 3 - Wall Mounted Printer Base, LB

INTERMEDIATE GEAR ASSEMBLY
REQUIREMENTS

- (1) CLEARANCE BETWEEN DRIVEN GEAR ON PRINTER AND INTERMEDIATE GEAR SHOULD BE

MIN. 0.004 INCH --- MAX. 0.008 INCH

- (2) THERE SHOULD BE SOME CLEARANCE BETWEEN RIGHT BELT RETAINER ON INTERMEDIATE GEAR ASSEMBLY AND SPACING CUTOUT LEVER ON PRINTER.
TO ADJUST

- (1) LOOSEN THREE MOUNTING SCREWS AND MAKE THEM FRICTION TIGHT. POSITION THE ASSEMBLY TOWARD FRONT OR REAR TO MEET REQUIREMENT (1).
(2) POSITION THE ASSEMBLY TOWARD THE LEFT TO MEET REQUIREMENT (2). TIGHTEN SCREWS

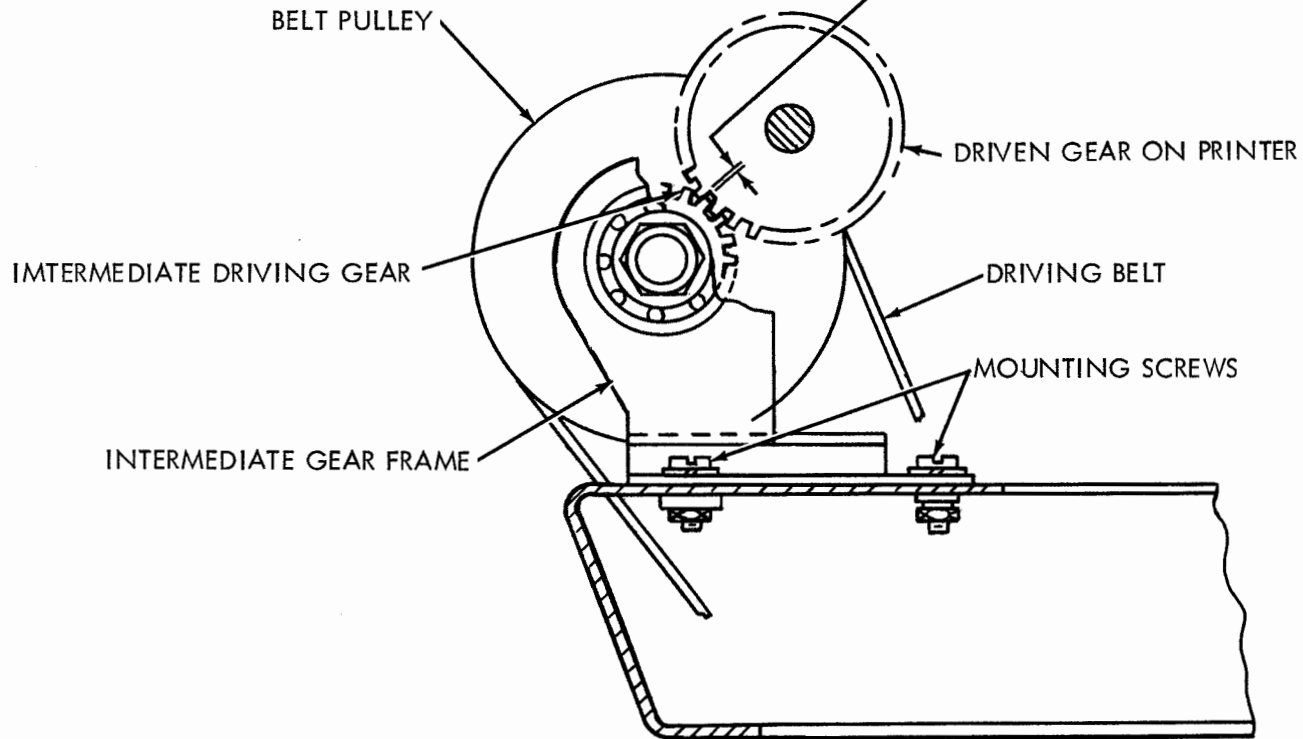

Figure 4 - Intermediate Gear Assembly Adjustment

TIMING BELT
REQUIREMENT

FORCE OF $2 \pm 1/2$ OZS. TO DEFLECT BELT $1/8$
INCH WHEN MEASURED MIDWAY BETWEEN PULLEYS.

TO ADJUST

WITH MOTOR PLATE MOUNTING SCREWS LOOSEN-
ED, SLIDE MOTOR TOWARD FRONT OF BASE TO
INCREASE TENSION OR TOWARD REAR OF BASE TO
DECREASE TENSION. TIGHTEN SCREWS.

DRIVEN PULLEY

MOTOR PULLEY

TIMING BELT

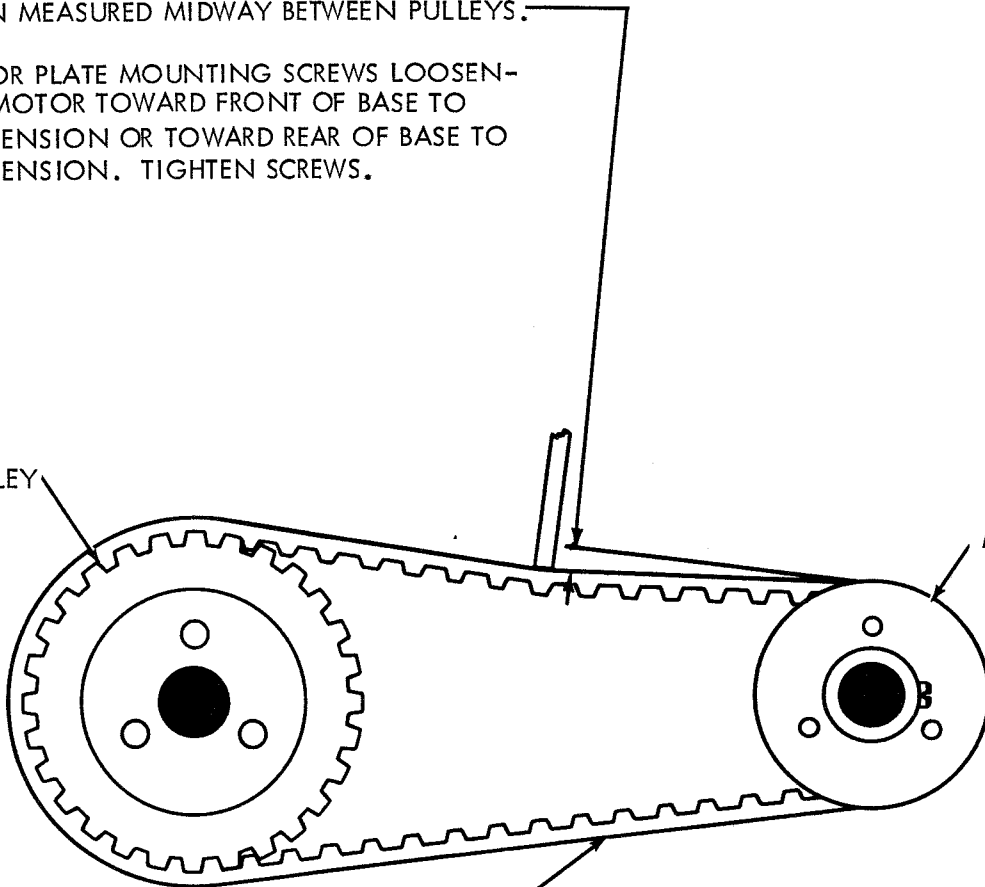

Figure 5 - Timing Belt Adjustment

HINGE MOUNTS

REQUIREMENT

KEYBOARD, PRINTER AND MOTOR UNIT IN PLACE. HINGE SHOULD BE PERPENDICULAR TO SIDE PLATE AS GAUGED BY EYE.

TO ADJUST

WITH MOUNTING SCREWS LOOSENED, MOVE THE HINGES UP OR DOWN TO MEET REQUIREMENT. TIGHTEN SCREWS.

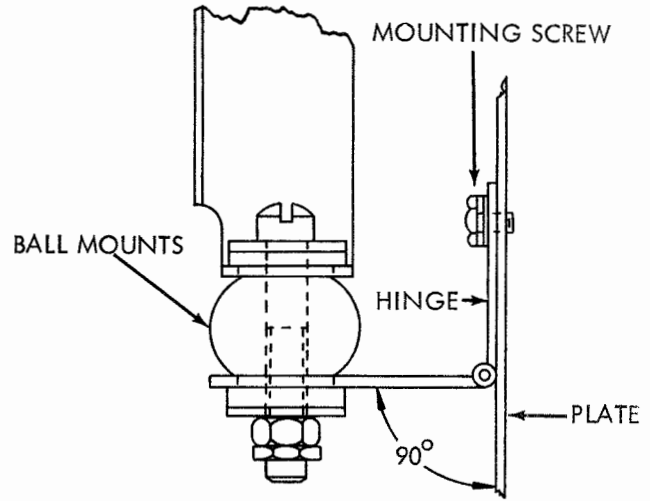

Figure 6 - Hinge Mount Adjustment

CAUTION

TO INSURE PROPER GROUNDING, PILE HARDWARE IN THE INDICATED ORDER.

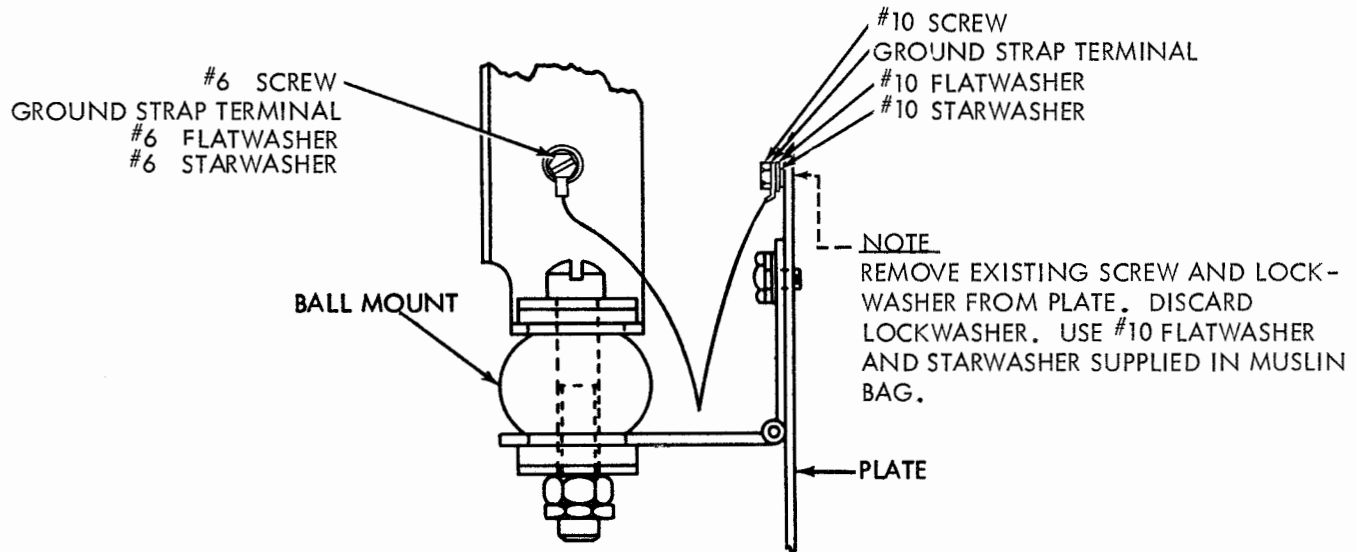

Figure 7 - Electrical Service Unit Ground Strap Attachment Points

NOTE
PERFORM ADJUSTMENTS WITH COVER REMOVED FROM BACK
PLATE ASSEMBLY.

(A) WINDOW DOOR HINGE MOUNTS
REQUIREMENT

WINDOW DOOR SHOULD LIE FLAT
ON SUPPORTING EDGES OF CABINET
AS GAUGED BY EYE.

TO ADJUST
LOOSEN TWO NUTS ON EACH HINGE.
POSITION DOOR. TIGHTEN NUTS.

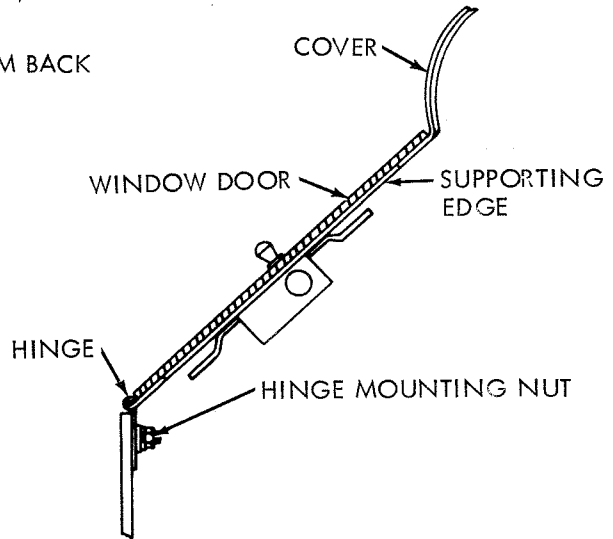

(B) LOWER DOOR HINGE MOUNTS
REQUIREMENT

DOOR SHOULD LIE FLAT AGAINST
COVER.

TO ADJUST
LOOSEN TWO NUTS ON EACH HINGE.
POSITION DOOR. TIGHTEN NUTS.

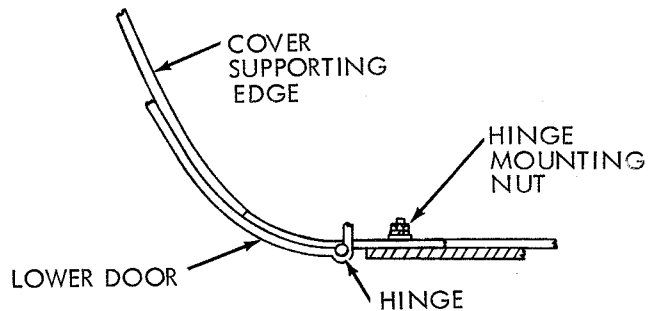

(C) LOWER DOOR LATCHES
REQUIREMENT

DOOR SHOULD LATCH SOLIDLY WITH
MAGNET LATCHES AND LIE FLAT
AGAINST COVER.

TO ADJUST
LOOSEN LATCH SCREWS. POSITION
LATCHES. TIGHTEN SCREWS.

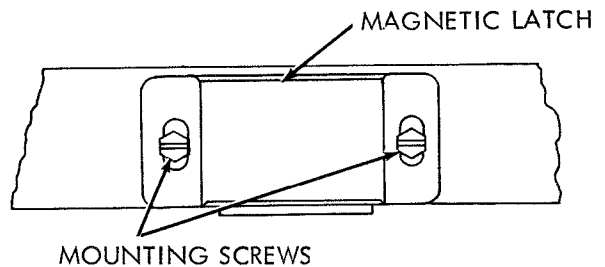

(D) COPYHOLDER
REQUIREMENT

THERE SHOULD BE SUFFICIENT TENSION
ON THE LINE GUIDE TO HOLD COPY
IN PLACE AND TO PREVENT THE LINE
GUIDE FROM SLIPPING DOWN ITS
SHAFT. LINE GUIDE SHOULD BE
PARALLEL TO COPYHOLDER TRAY.

TO ADJUST
REMOVE THE MOUNTING SCREWS OR
NUTS FROM THE LINE GUIDE SHAFT
AND TURN THE SHAFT. REMOUNT THE
SHAFT AND TIGHTEN SCREWS OR NUTS.
BEND LINE GUIDE TO MAKE IT PARALLEL
TO COPYHOLDER.

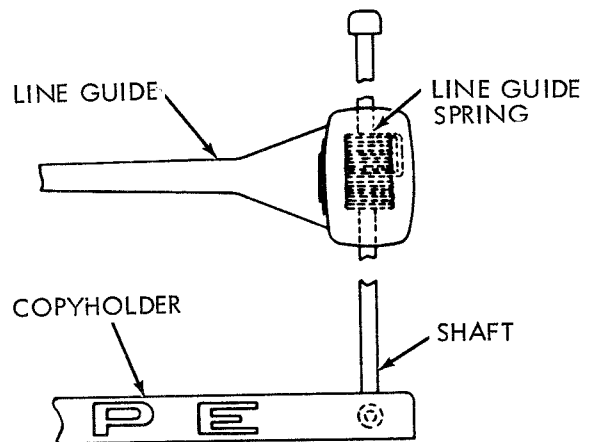
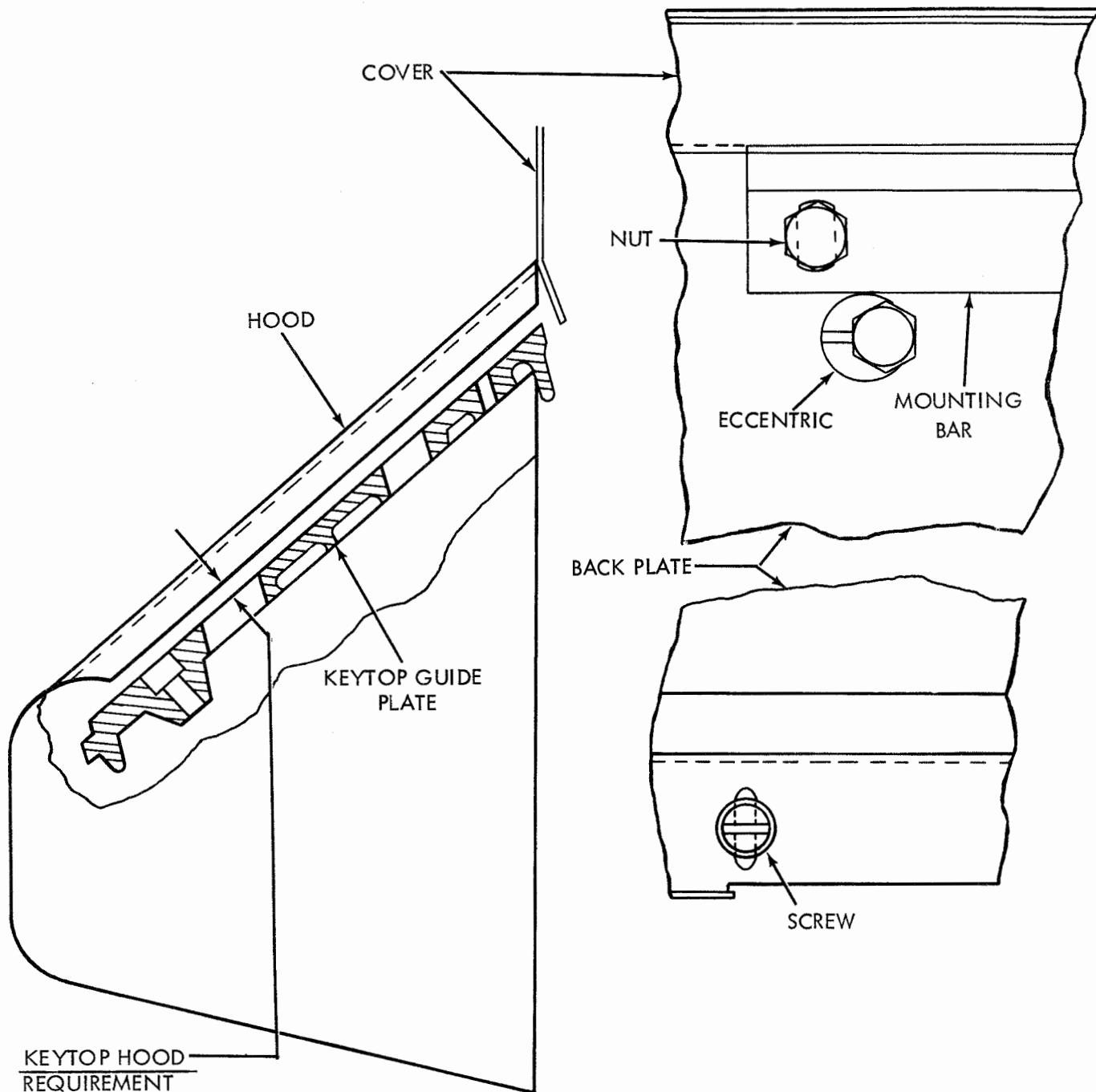

Figure 8 - Cover Hinge, Latch and Copyholder Adjustments



KEYTOP HOOD
REQUIREMENT

WITH COVER IN PLACE, GAP BETWEEN KEYTOP HOOD
AND GUIDE PLATE SHOULD BE

MIN. 0.090 INCH --- MAX. 0.125 INCH

TO ADJUST

LOOSEN THE TWO NUTS (ON THE COVER MOUNTING
BAR) AND THE LOWER SCREWS. ADJUST ECCENTRICS TO
MEET REQUIREMENT. TIGHTEN NUTS.

Figure 9 - Keytop Hood Adjustment - Send Receive Set

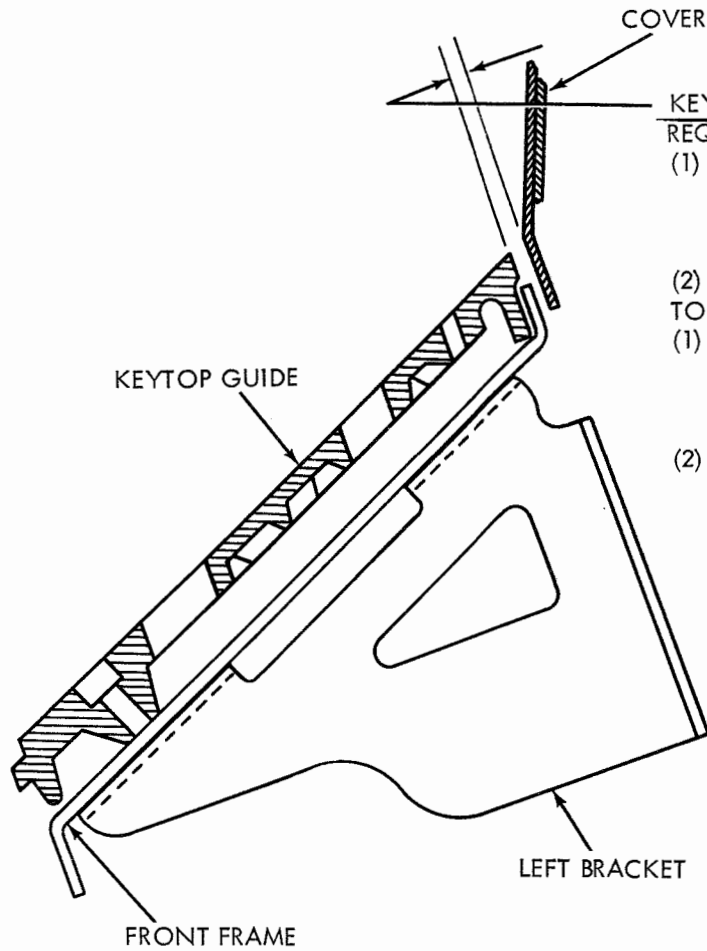

KEYTOP AND COVER REQUIREMENTS

- (1) WITH COVER IN PLACE, GAP BETWEEN BACK EDGE OF KEYTOP GUIDE AND LIP OF COVER SHOULD BE
MIN. 0.090 INCH --- MAX. 0.0125 INCH
- (2) GAP SHOULD BE PARALLEL TO ADJUST
- (1) WITH NUT (SECURING LARGE CENTRAL MOUNT) LOOSENED, MOVE UPPER SUPPORT BAR BY MEANS OF ITS ELONGATED SLOT. TIGHTEN NUT.
- (2) IF PARALLEL CONDITION IS NOT MET BY ABOVE ADJUSTMENT, LOOSEN FOUR BOLTS SECURING LOWER SUPPORT BAR. POSITION LOWER SUPPORT BAR TO MEET REQUIREMENTS. TIGHTEN BOLTS.

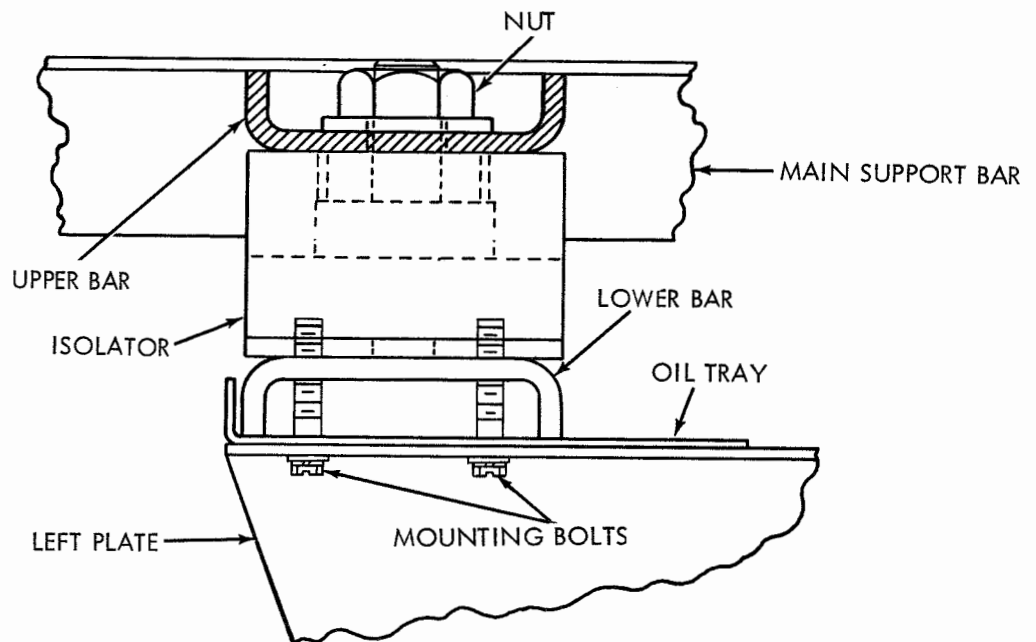
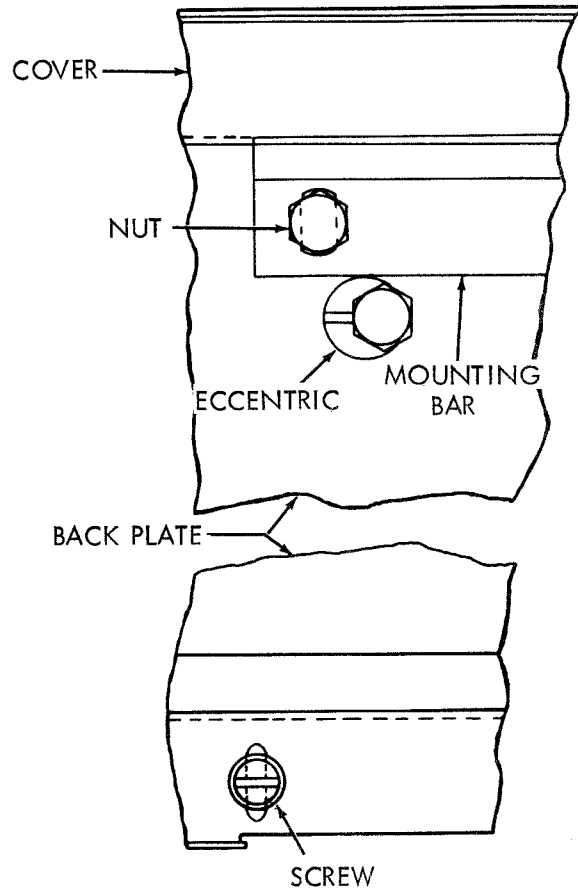
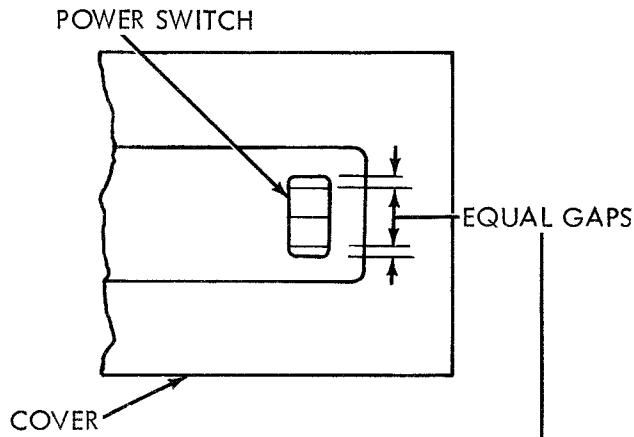

Figure 10 - Keytop and Cover Adjustment - Send Receive Set



COVER REQUIREMENT

WITH COVER IN PLACE, POWER SWITCH SHOULD BE CENTRALLY LOCATED AS GAUGED BY EYE.

TO ADJUST

LOOSEN THE TWO NUTS (ON THE COVER MOUNTING BAR) AND THE LOWER SCREWS. ADJUST ECCENTRICS TO MEET REQUIREMENT. TIGHTEN NUTS.

Figure 11 - Cover Adjustment - Receive Only Set

POWER SWITCH
REQUIREMENT

WITH COVER IN PLACE, DEFLECTED SURFACE OF POWER SWITCH, INDICATING EITHER ON OR OFF, SHOULD BE FLUSH WITH COVER SURFACE.

TO ADJUST

- (1) REMOVE COVER. WITH ADJUSTING SCREWS FRICTION TIGHT, POSITION SWITCH. TIGHTEN SCREWS.
- (2) IF REQUIREMENT CANNOT BE MET WITH ABOVE ADJUSTMENT, LOOSEN NUT SECURING LARGE CENTRAL MOUNT AND MOVE THE UPPER SUPPORT BAR BY MEANS OF ITS ELONGATED SLOT. REMOVE COVER. TIGHTEN NUT.

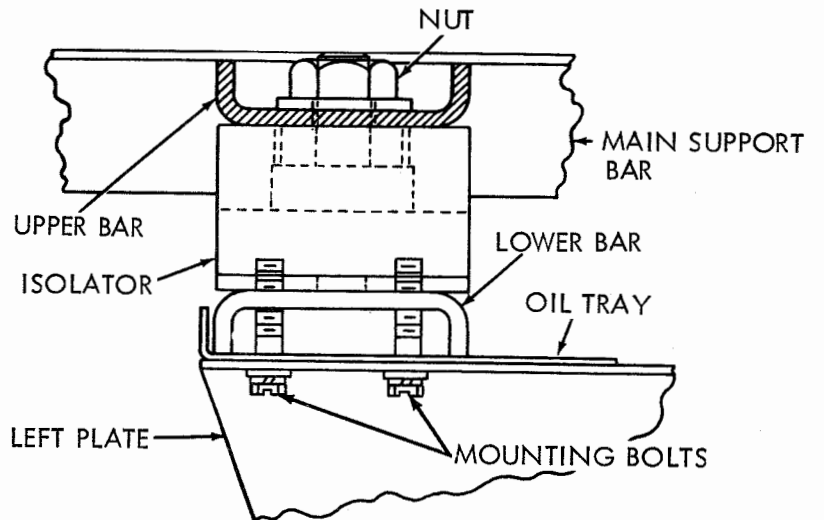
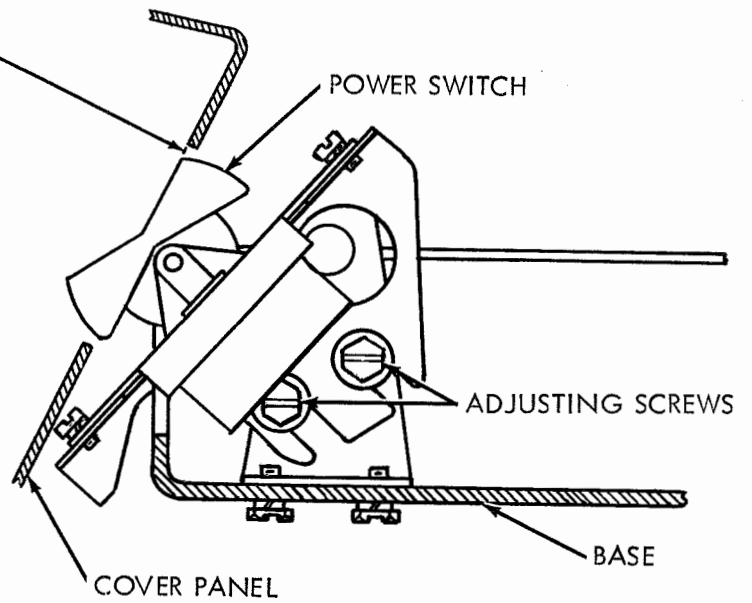

Figure 12 - Power Switch Adjustment - Receive Only Set

(50170S)

KEYLEVER

REQUIREMENT (THREE PLACES)

WITH COVER IN PLACE, CLEARANCE BETWEEN SURFACE OF LEVER ADJUSTING SCREW AND OUTER SURFACE OF COVER SHOULD BE

MIN. 7/8 INCH --- MAX. 15/16 INCH

TO ADJUST

REMOVE KEYLEVER ASSEMBLIES. TURN ADJUSTING SCREW TO MEET REQUIREMENT. (SLOT IN SCREW SHOULD BE HORIZONTAL AFTER ADJUSTING). REMOVE COVER AND REPLACE KEYLEVER ASSEMBLIES. INSERT KEYS IN THEIR PROPER OPENINGS.

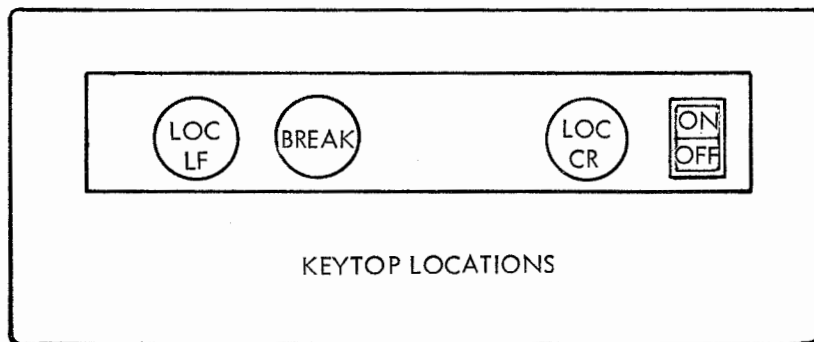
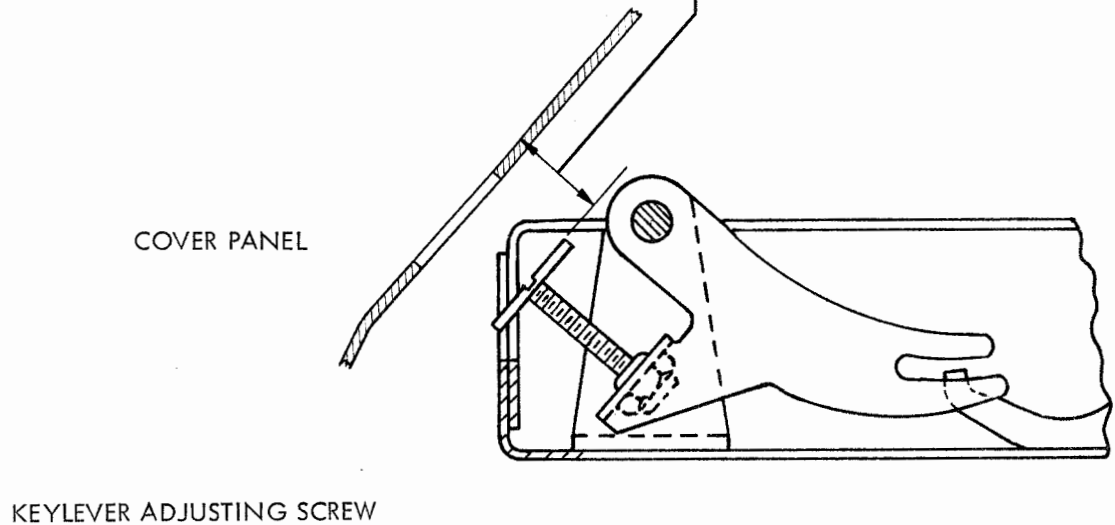

Figure 13 - Keylever Adjustment - Receive Only Set

(A) PAPER GUIDE

REQUIREMENT

WITH TYPING UNIT IN PLACE AND LARGE AND SMALL DOORS LATCHED, CLEARANCE BETWEEN PAPER GUIDE AND PLATEN SHOULD BE:

MIN. $\frac{3}{64}$ INCH --- MAX. $\frac{5}{64}$ INCH

TO ADJUST

LOOSEN GUIDE MOUNTING SCREWS. ADJUST PAPER GUIDE PARALLEL TO PLATEN. TIGHTEN SCREWS.

(B) WINDOW

REQUIREMENT

WITH SMALL DOOR CLOSED, PARALLEL CLEARANCE BETWEEN PAPER GUIDE AND WINDOW EDGE SHOULD BE:

MIN. 0.080 INCH --- MAX. 0.110 INCH

TO ADJUST

LOOSEN FOUR MOUNTING SCREWS HOLDING WINDOW CLAMPS IN POSITION. MOVE WINDOW TO MEET REQUIREMENT. TIGHTEN SCREWS.

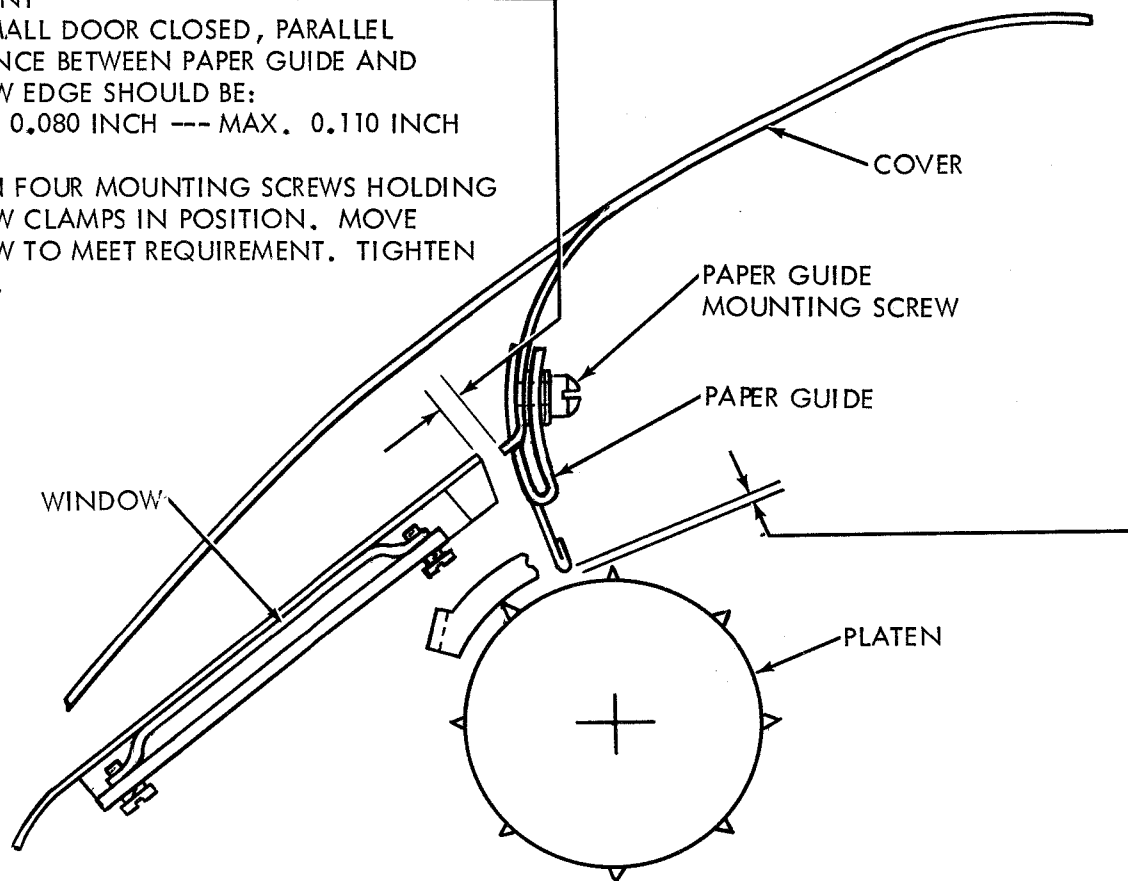

Figure 14 - Paper Guide and Window Adjustments

(50170S)

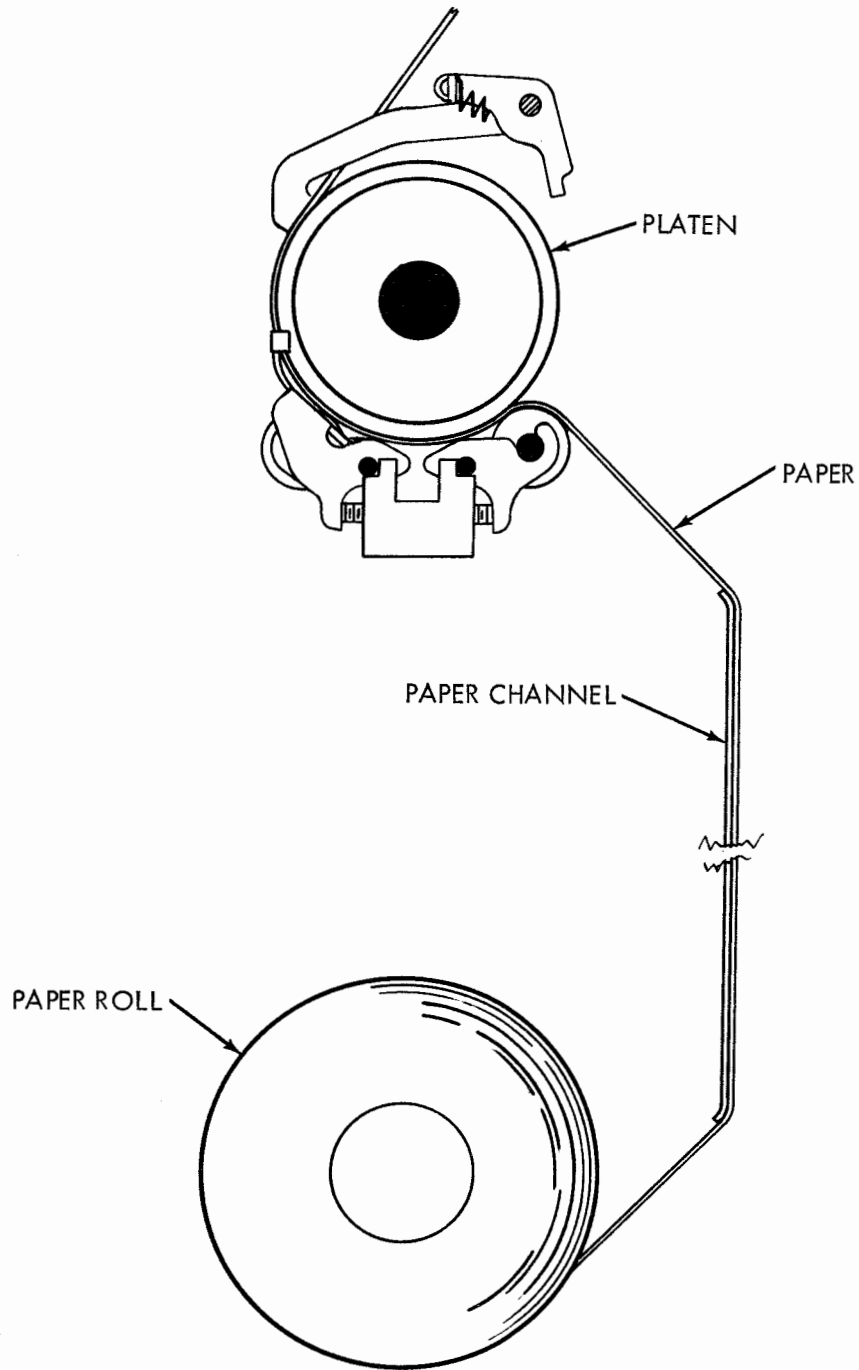

Figure 15 - Path of Paper (Friction Feed Units Only)

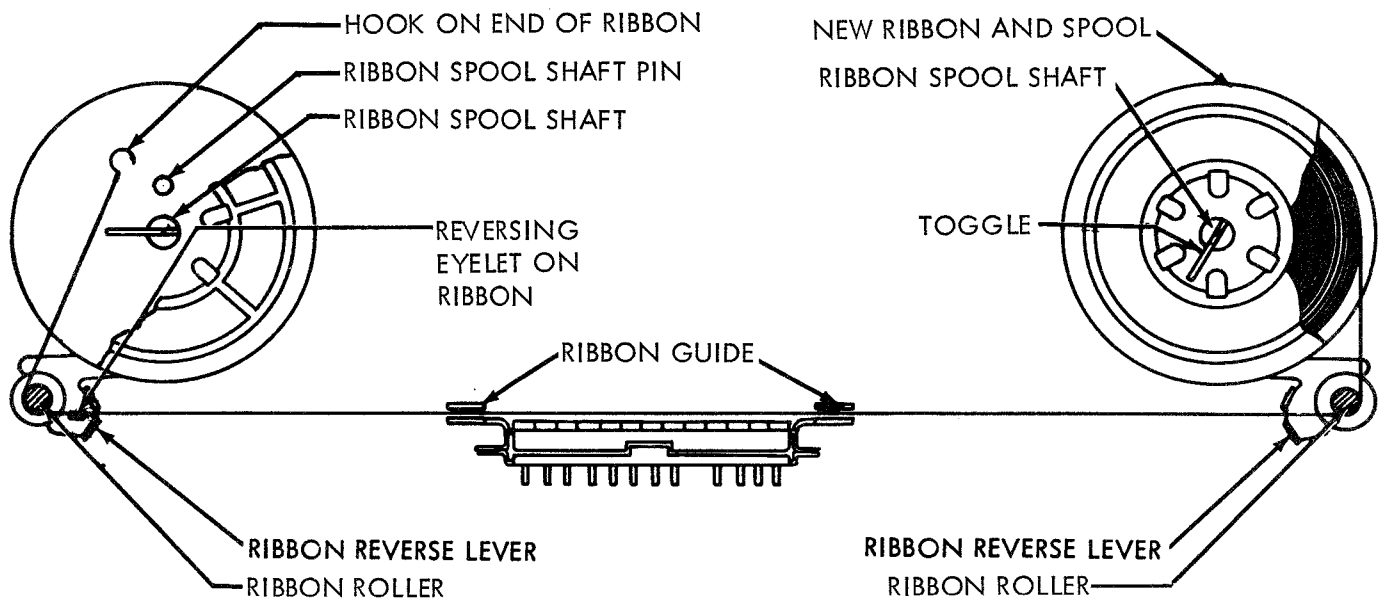

Figure 16 - Path of Ribbon

