

INSTRUCTIONS FOR INSTALLING THE 323604 (FOR
VCL385 KSR SET) AND 323605 (FOR VCL386 OR
VCL387 ASR SET) MODIFICATION KITS TO UPDATE
MODEL 35 PRIVATE LINE SETS HAVING THE 305446
SIGNAL REGENERATOR

1. GENERAL

1.01 The 323604 and 323605 modification kits update the 305446 regenerator assembly supplied with the sets to provide signal regeneration.

1.02 The 323604 and 323605 kits provide a regenerated line signal by changing three wires for VCL386 and 387 ASR Sets (two wires for the VCL385 KSR Set), adding the regenerator circuit card, and changing the contact assemblies in the keyboard and transmitter distributor. The 319946 and 321916 contact assemblies contain gold-copper contacts.

1.03 The 323605 kit consists of:

1	2669	Washer	1	312325	Signal Regenerator (also kit 323604)
1	177894	Nut			
2	179800	Toggle (1 in 323604)	1	319946	Contact Assembly (also kit 323604)
1	182520	Rectifier			
4	195241	Screw (2 in 323604)	1	321915	Eccentric
1	199449	Switch Section w/Strap	1	321916	Contact Assembly

1.04 For parts ordering information, other than the parts in the kits, and for standard adjustment and lubrication procedure, refer to the standardized information.

2. INSTALLATION (Figures 1 to 6)

2.01 Isolate the set from all power sources. Remove 199416 circuit card from the signal regenerator assembly and replace it with the 312325 circuit card furnished with the 323604 or 323605 modification kit. Make the following wiring changes:

(1) VCL385 KSR Set (323604 Modification Kit)

Remove the cover on the C wiring field. Refer to 7876WD schematic wiring diagram* and 7877WD actual wiring diagram furnished with the 323604 modification kit. The wiring diagrams show wiring before and after the change.

(a) Remove the strap from C-2C to C-4D and place it on C-4D and C-5A.

- (b) Move the white-yellow wire (SRG-H-W-Y) on C-6F to C-5A.
- (c) Replace the cover on the C wiring field.

(2) VCL386 or VCL387 ASR Set (323605 Modification Kit)

Remove the cover on the C wiring field. Refer to 7913WD schematic wiring diagram and 7914WD actual wiring diagram furnished with the 323605 modification kit. The wiring diagrams show wiring before and after the change.

- (a) Move the white-yellow wire (SRG-H-W-Y) on C-6H to C-4G.
- (b) Move the white-brown wire (H12-W-BR) on C-5C to C-4G.
- (c) Move the white-black-orange wire (F-34-W-BK-O) on C-5C to C-4G.
- (d) Replace the cover on the C wiring field.

- 2.02 The 192485 contact assembly in the keyboard (LK or LAK - both kits) must be moved and replaced, where applicable, with the 319946 contact assembly (LK or LAK).

Note: If the signal generator contacts have been used in a circuit with a power level greater than 40 v dc at 20 ma they should be replaced.

- (1) Isolate the set from all power sources.
 - (2) Remove and retain the 195053 insulating cover from the 192485 contact assembly by loosening its mounting screw. (See Figure 3.)
 - (3) Slide back the protective insulation from the 160593 terminal (part of the 192485 contact assembly). Unsolder and remove the two wires from the terminals. Note the wire color coding while removing and retain for reinstallation.
 - (4) Remove the 192485 contact assembly from the keyboard by loosening the two nuts on the mounting screws. (See Figure 3.)
 - (5) Remove the two locknuts, lockwashers and the clamp plate from the 192485 contact assembly mounting screws and install them on the new 319946 contact assembly mounting screws.
 - (6) Install the 319946 assembly in the reverse manner as the old assembly was removed and tighten the nuts on the assembly friction tight.
 - (7) Adjust the 319946 contact assembly in accordance with the standardized information. (Customers other than Bell, see Teletype Bulletin 280B.)
 - (8) If strobe facilities are available refine gap as outlined in Figure 6.
 - (9) For signal generator contact replacement refer to Paragraph 2.04.
- 2.03 The 192605 contact assembly in the Transmitter Distributor (LXD) must be replaced by a 321916 contact assembly. (Kit 323605 -VCL386 and VCL387 ASR only.)

Note: If the signal generator contacts have been used in a circuit with a power level greater than 40 v dc at 20 ma they should be replaced.

- (1) Remove the 192605 contact assembly by removing the contact bracket eccentric screw and the mounting screw. Retain the bracket mounting screw and lockwasher.
- (2) To remove the wires from the assembly, slide back the plastic insulation and unsolder the connections. Retain the color code for reinstallation of new assembly.
- (3) Remove the plastic cover from the new contact assembly (321916) and solder the wires to the terminals using the same configuration as in the old assembly. After soldering, slide the plastic insulation back over the terminals.
- (4) Install the contact assembly 321916 in the LXD with the hardware retained in Paragraph 2.03 (1) and the 321915 eccentric, 2669 lockwasher, and 177894 nut furnished with the modification kit. (See Figure 4.)
- (5) Adjust the 321916 timing contact assembly as specified in Figure 5. Replace the plastic cover.
- (6) If facilities are available for strobing the contact assemblies in the LXD, LK, and LAK then the contact gaps should be refined in accordance with requirements specified in Figure 6 (Teletype Bulletin 280B).

2.04 Signal generator contact replacement must be done if the contacts have been used in a circuit with a power level greater than 40 v dc at 20 ma. Proceed as follows: (Parts are shown in Bulletin 1187B, Section 574-222-800 or Bulletin 1201B, Section 574-221-800)

- (1) Remove the 3599 nut and 3640 lockwasher which fasten the 154131 contact cover, and remove the cover.
- (2) Remove the 125126 screw which fastens the 179800 toggle to the 156644 drive link. Lift the toggle out and unsolder the 195648 green jumper wire from the toggle.
- (3) Remove the two 195241 screws with contacts, and replace them with the two new 195241 screws with contacts.
- (4) Solder the 195648 green jumper wire to the new 179800 toggle and install the new toggle with the 125126 screw.
- (5) Make the signal generator contact box adjustment as given in the standardized information. (Customers other than Bell refer to Teletype Bulletin 280B.)
- (6) Replace the 154131 contact cover and fasten with the nut and lockwasher previously removed.

2.05 Mode Switch Modification
(ASR only - Modification Kit 323605 - VCL 386 and VCL 387)

(1) Remove the two nuts and two lockwashers which hold the rotary switch assembly together. Lift off switch sections 5, 4, and 3, and remove the brown-blue, red, blue, and red-green wires, and remove the end of the strap whose other end is fastened to terminal 7 of section 2. Reassemble the switch using the 199449 Switch section for section 3 and solder the previously removed four wires and strap to this section as shown on 7915WD, issue 2 or above. Make sure that all sections are oriented as shown, and that the key slots in the rotating portion in the center of the sections are all lined up on the same flat surface on the side of the switch shaft.

(2) Remove the strap between terminal 9 of section 1 and terminal 7 of section 2 and replace it with the 182520 Rectifier (or diode). Install with the banded end toward terminal 7 of section 2. Refer to 7915WD, issue 2 or above.

3. ADJUSTMENTS AND LUBRICATION - There are no adjustments or lubrication for the kits other than that the 319946 contact assembly of the 323604 kit must be checked and adjusted, if necessary, as given on Figure 1. The 321916 contact assembly of the 323605 kit must be checked and adjusted, if necessary, as given on Figure 2.

*

*

*

FIGURE 1

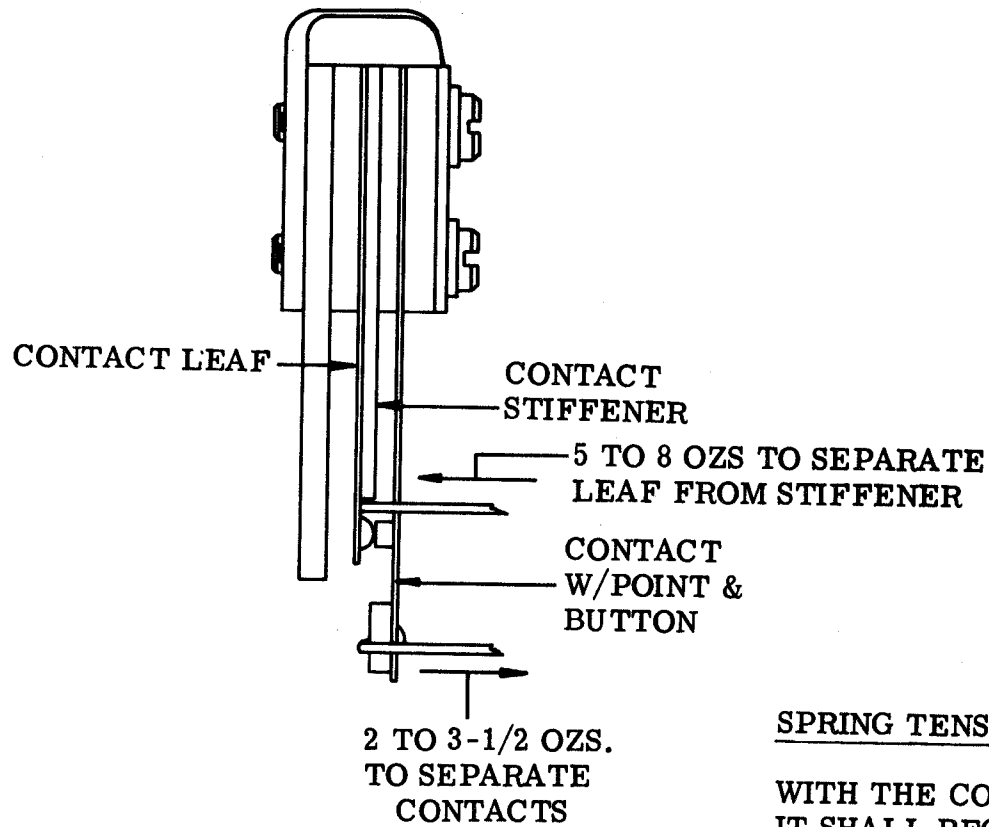

SPRING TENSION REQUIREMENTS

WITH THE CONTACT POINTS SEPARATED IT SHALL REQUIRE 5 TO 8 OZS. TO SEPARATE THE CONTACT LEAF FROM THE CONTACT STIFFENER. WITH THE CONTACT POINTS CLOSED, IT SHALL REQUIRE 2 TO 3-1/2 OZS. TO SEPARATE THE CONTACT POINTS.

FIGURE 2

REQUIREMENT #1:
CONTACT POINTS SHALL BE IN LINE AND
THE HEAD OF THE 321922 PLUNGER SHALL
BE CENTERED IN ITS HOLE IN THE 321920
SPRING—BOTH AS GAGED BY EYE.

TO ADJUST: #1
POSITION CONTACT SPRINGS WITH 123874
SCREWS FRICTION TIGHT.
TIGHTEN SCREWS FIRMLY.

REQUIREMENT #3:
3-1/2 to 4-1/2 OZS. TO
SEPARATE CONTACTS.

TO ADJUST:
BEND 321921 SPRING.

REQUIREMENT #2:
WITH 321922 PLUNGER
DEPRESSED FLUSH WITH ITS
BUSHING, CONTACT GAP TO
BE .045 TO .065 INCH.

TO ADJUST:
BEND 321920 SPRING.

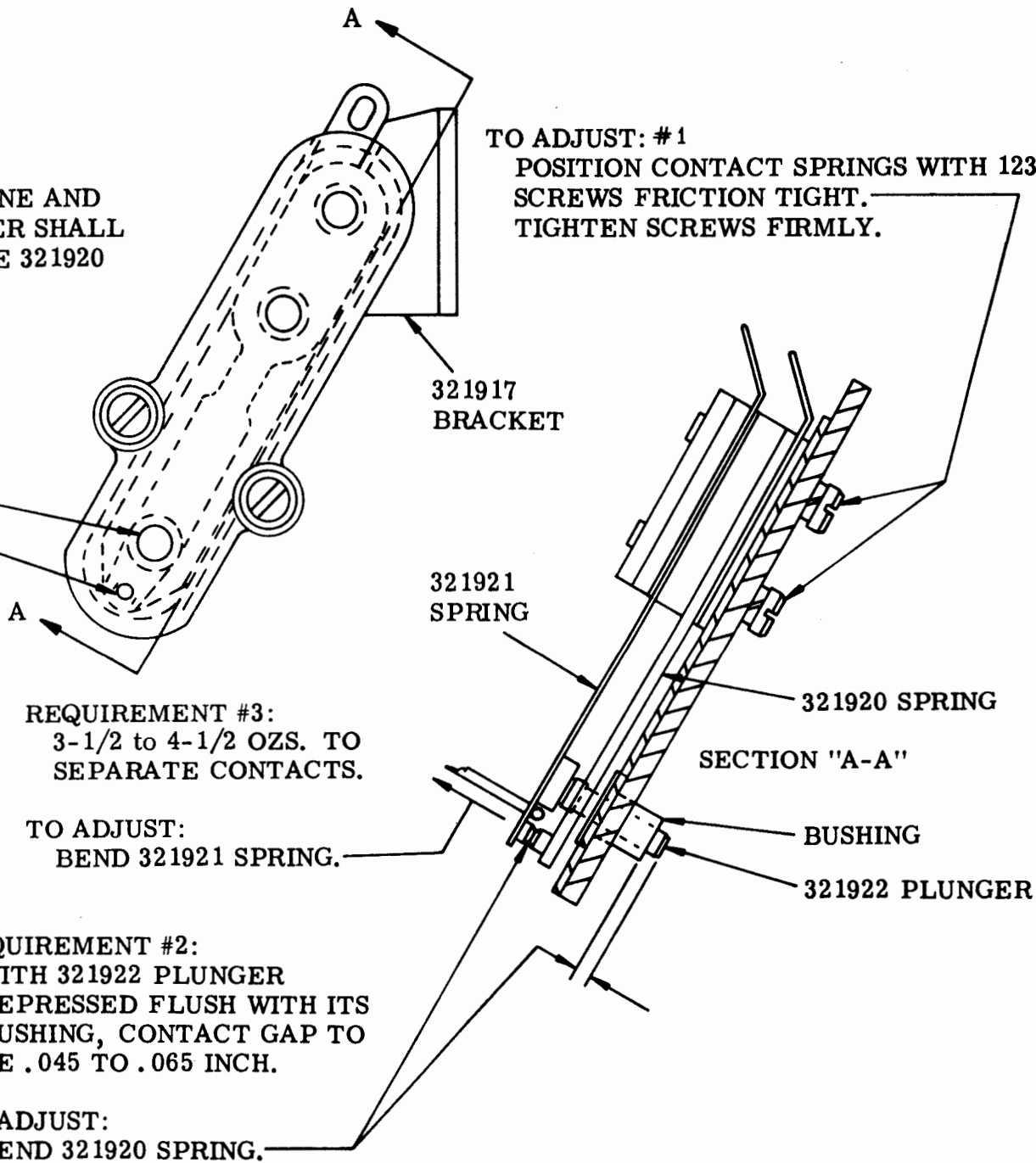

50479S

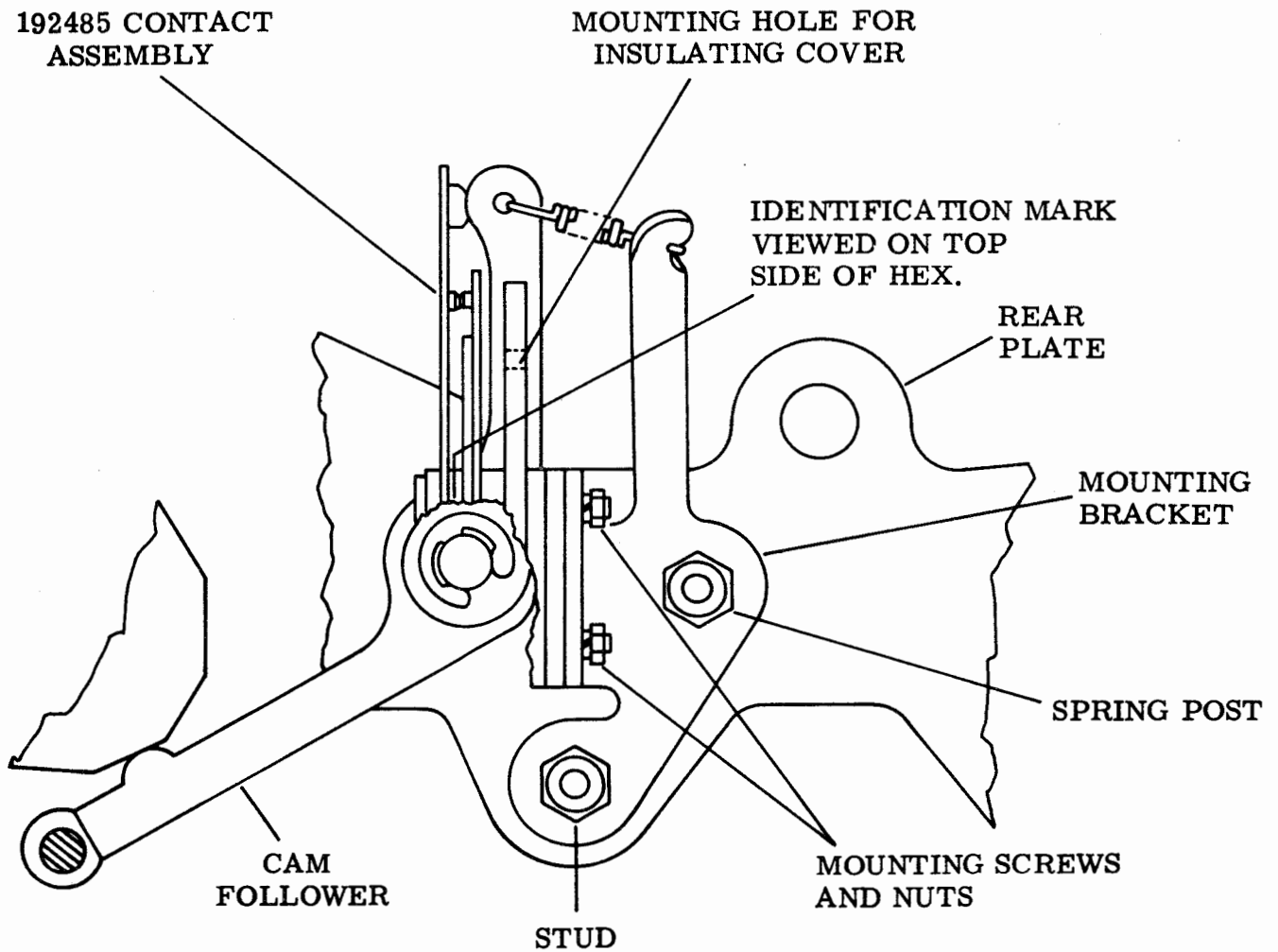
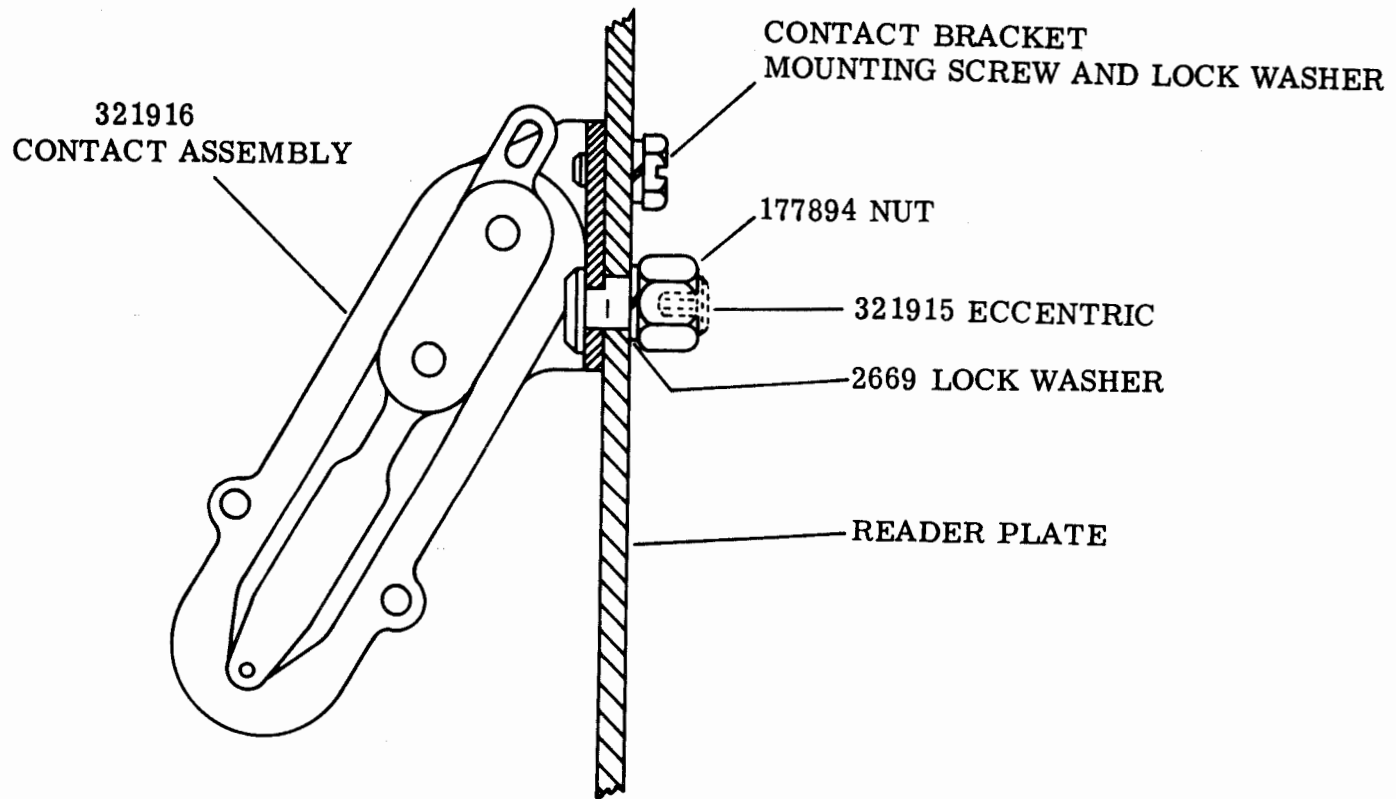

FIGURE 3

FIGURE 4



50479S

FIGURE 5

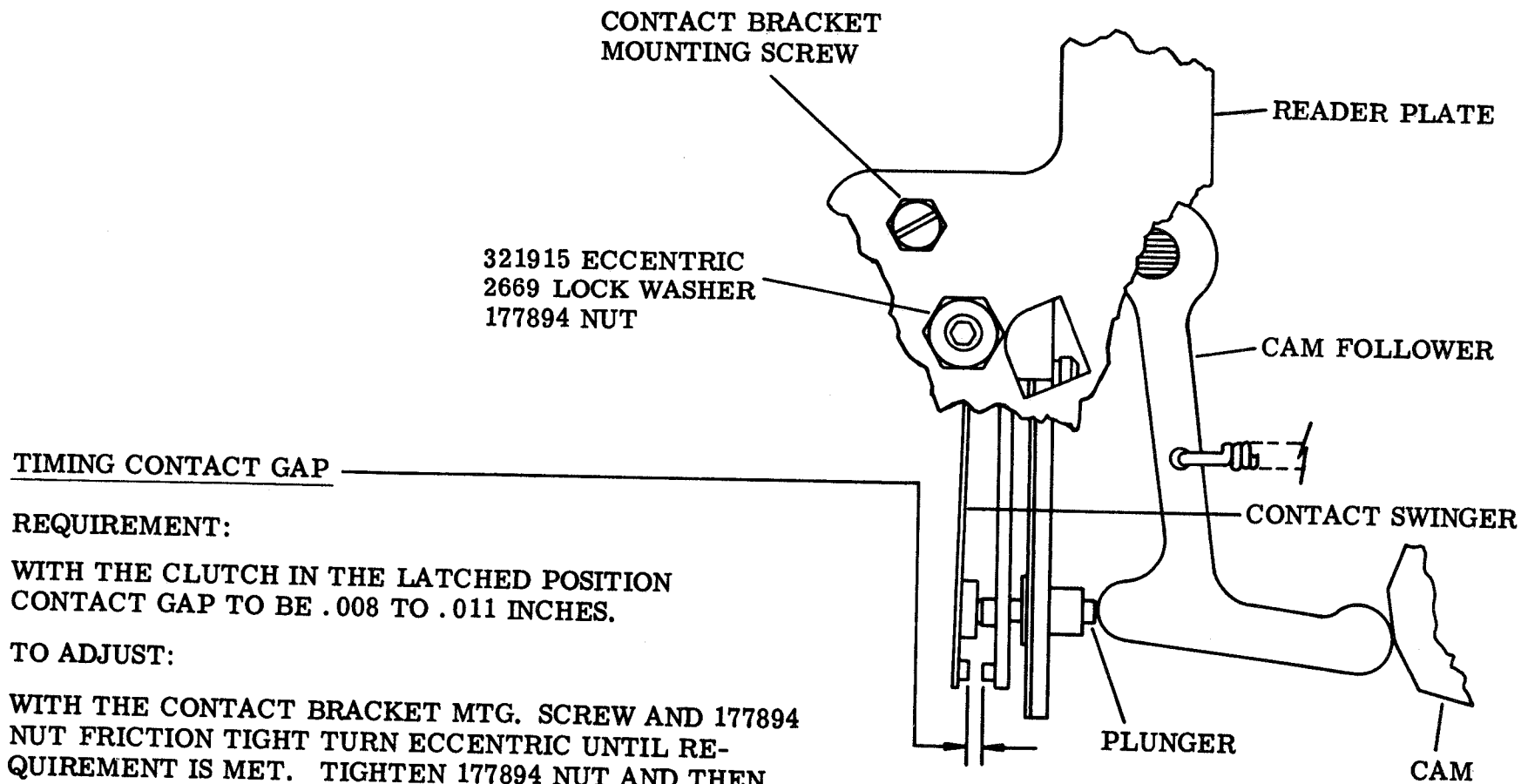

50479S

TIMING CONTACT GAP

REQUIREMENT:

WITH THE CLUTCH IN THE LATCHED POSITION
CONTACT GAP TO BE .008 TO .011 INCHES.

TO ADJUST:

WITH THE CONTACT BRACKET MTG. SCREW AND 177894
NUT FRICTION TIGHT TURN ECCENTRIC UNTIL RE-
QUIREMENT IS MET. TIGHTEN 177894 NUT AND THEN
THE BRACKET MTG. SCREW. RECHECK GAP AND REFINE
IF NECESSARY.

CHECK FOR PROPER ADJUSTMENT:

WITH CAM FOLLOWER ON LOW PART OF CAM AND CLEARANCE TAKEN
UP BETWEEN PLUNGER AND CAM FOLLOWER THERE MUST BE SOME
CLEARANCE BETWEEN PLUNGER AND CONTACT SWINGER.

Figure 6

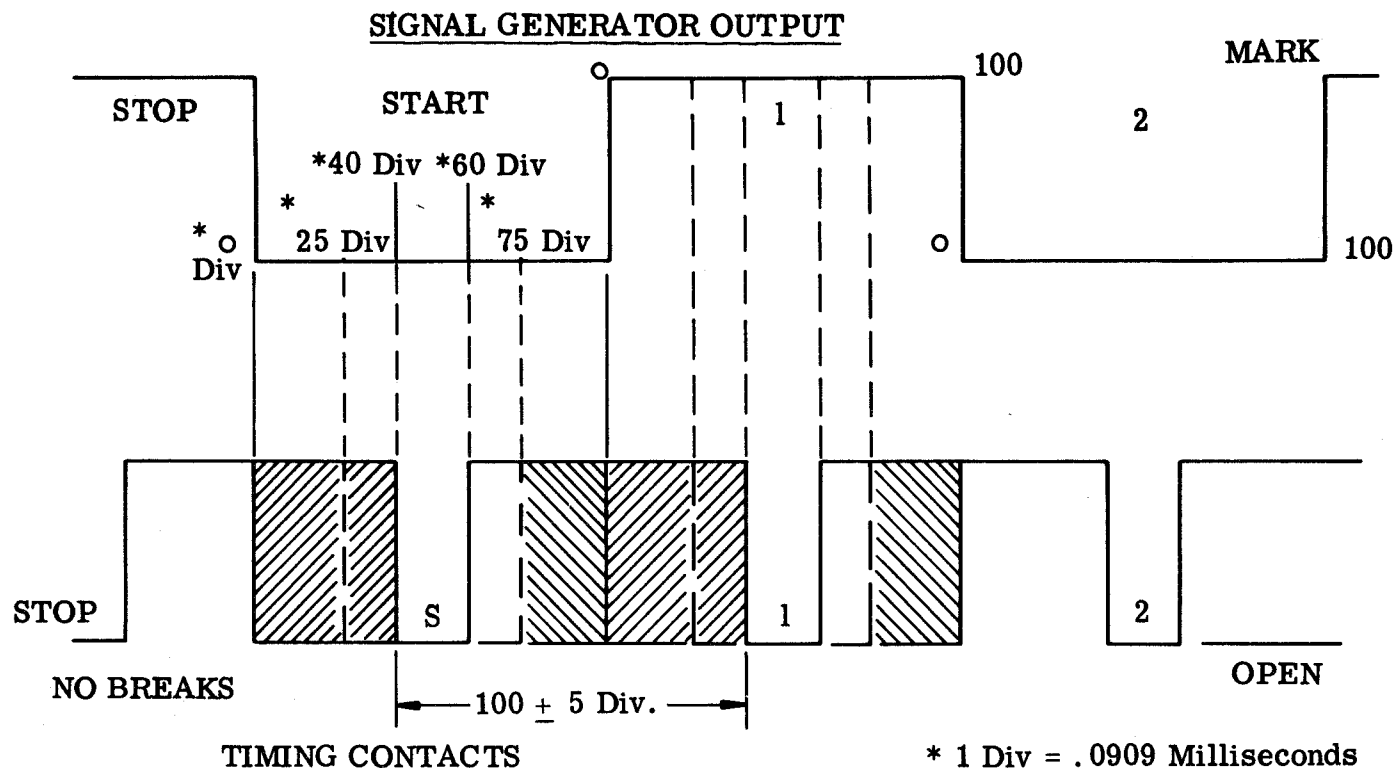

50479S

Timing Contacts Operating Requirements With Stroboscope:

- a. With the signal generator and stroboscope set up in accordance with the standardized information (customers other than Bell refer to Teletype Bulletin 280B), the light image of the timing contacts shall meet the following requirements for speeds up to and including 100 WPM.
 - (1) Open for a minimum of 20 divisions between the 25 div. and 75 div. points of each 100 div. pulse.
 - (2) The close to open transitions shall be in multiple of 100 div. \pm 5 div. from the close to open transition of the start pulse.
 - (3) There shall be no contact break between the 0 div. point and the close to open transition point and no contact break between the 75 div. point and 100 div. point of each pulse. There shall be no contact make between the 175 div. point and the 200 div. point of the stop pulse.