

Y-TYPE RELAYS

REQUIREMENTS AND ADJUSTING PROCEDURES

(FOR CONDENSED SECTION, SEE 040-937-701)

1. GENERAL

1.01 This section covers Y-type relays.

1.02 This section is reissued to add spring tension values omitted from Issue 8 (Fig. 101 through 243, Fig. 245, and Fig. 300 through 350). This reissue does not affect the Equipment Test List.

1.03 Reference shall be made to Section 020-010-711 covering general requirements and definitions for additional information necessary for the proper application of the requirements listed herein.

1.04 **Operate:** A relay is said to *operate* if, when current is connected to the winding, the armature moves sufficiently to cause all normally open contacts to close and all normally closed contacts to open and to cause the embossed surface of the armature to rest against the core.

1.05 **Nonoperate:** A relay is said to *nonoperate* if, when current is connected to its winding, the armature does not move from its position against the backstop.

1.06 **Hold:** A relay is said to *hold* if, after the current is reduced abruptly from the soak or operate value to the hold value, the armature does not move from the operated position. (See Note 1 of requirement 2.22.)

1.07 **Release:** A relay is said to *release* if, when the current is reduced abruptly to the release value or the current is removed, the armature moves from the core to its unoperated position in which the armature is resting against the backstop,

and all normally open contacts are open and all normally closed contacts are closed. (See Note 2 of requirement 2.22.)

1.08 **Armature gap** is the gap between the core and the embossing on the armature in any position the armature may assume between the unoperated and the operated positions of the relay.

1.09 **Armature travel** is the armature gap when the armature is resting against the backstop.

1.10 The term **contact spring** when used in this section includes, unless otherwise specified, the contact bars welded to the end of the spring. The front end of the spring may or may not be bifurcated.

1.11 A **pretensioned spring** is a spring which has been tensioned during its manufacture. Such a spring may be recognized by one or more distinct bends between the insulators and the contact end of the spring.

1.12 Since the bends in pretensioned springs are formed during manufacture to provide the necessary tensions, these bends should not be disturbed during adjustment.

1.13 A **pair of contacts** as referred to in this section consists of a single contact bar of one contact spring and the corresponding contact bar on the opposing contact spring.

1.14 The terms **contact make** or **break** apply to the electrical circuit between the two springs. Contact make may involve the closing of only one of the two parallel pairs of contacts. Contact break involves the opening of both parallel pairs of contacts.

SECTION 040-522-701

1.15 The year of manufacture of Y-type relays is stamped on the spoolhead preceded or followed by dashes, three to indicate the first quarter, two the second quarter, one the third quarter, or none the last quarter.

2. REQUIREMENTS

2.01 **Cleaning:** The contacts and other parts of the relay shall be cleaned in accordance with the section covering cleaning and reconditioning relay contacts. After cleaning any contact, a check shall be made to see that both contacts on the bifurcated spring involved meet requirement 2.19(c).

2.02 **Relay Mounting:** Relays shall be fastened securely to the mounting plate.

Gauge by feel by grasping the core and armature between the thumb and forefinger and attempting to move the relay.

2.03 Vertical Clearance

(a) The clearance between the springs of the relay and apparatus mounted directly above or below shall be

Min 1/4 inch

Gauge by eye.

Note: This clearance is satisfactory if it can be obtained by removing the covers of the apparatus directly above or below, provided such covers are readily removable.

(b) Springs shall not touch the relay cover or the magnetic shields if provided.

Gauge by eye.

2.04 Cover Spring and Cover Guide Pressure and Cover Cap Tightness

(a) The cover cap on relays so equipped shall fit snugly. The relay cover shall be securely held in position when the cover cap is being removed and shall resist lateral and vertical displacement during the routine relay maintenance procedures.

Gauge by feel.

(b) **Fig. 1(A):** The cover spring shall bear on the front spoolhead when the cover is off.

Gauge by feel.

(c) **Fig. 1(B):** The free end of the cover guide shall bear on the core when the cover is removed.

Gauge by feel.

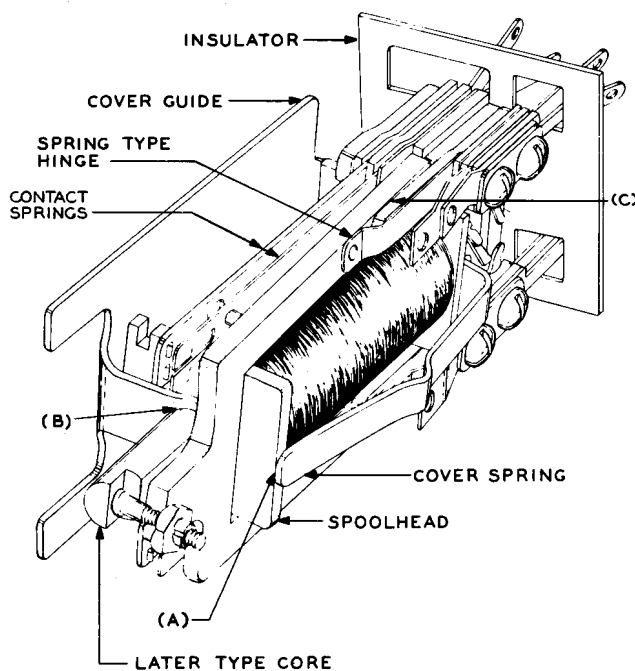

Fig. 1—Y-Type Relay Equipped With Spring-Type Hinge and Arranged for Mounting Individual Cover

2.05 Contact Alignment

(a) **Fig. 2(A):** On relays equipped with standard contacts, the contacts shall line up so the width of the contact surface of each contact bar falls wholly within the length of its mating bar.

Gauge by eye.

(b) **Fig. 3(A):** On relays equipped with heavy contacts, the contact alignment shall be within the limits indicated in Fig. 3.

Gauge by eye.

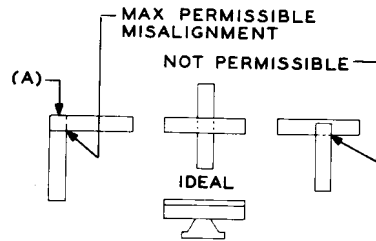

Fig. 2—Alignment of Contact Surfaces—Standard Contacts

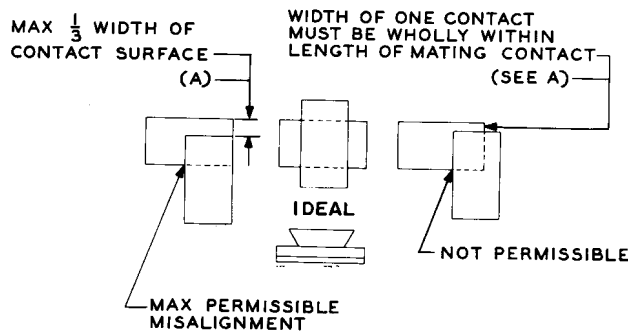

Fig. 3—Alignment of Contact Surfaces—Heavy Contacts

2.06 Spring Tang Position

(a) The spring tang shall not rub on the spoolhead when moved from its normal position of rest on the spoolhead in the direction of spring travel.

Gauge by eye and feel.

(b) The free end of the spring tang shall overlap the vertical edge of the spoolhead [Fig. 4(A)].

(1) On relays manufactured prior to the second quarter of 1948, the full width of the spring tang shall lie entirely within the projection of the top and bottom edges of the slots in the spoolhead.

(2) On relays manufactured during the second quarter of 1948 and subsequently, the spring tang may project 1/3 of its width above the top edge of the slot in the spoolhead.

Gauge by eye and feel.

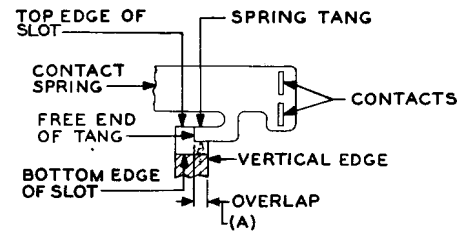

Fig. 4—Spring Tang Position

2.07 Adjusting Stud Clearance: Fig. 5(A)—On a relay having an adjusting stud, there shall be a clearance between the armature and the adjusting stud in all positions of the armature travel.

Gauge by eye.

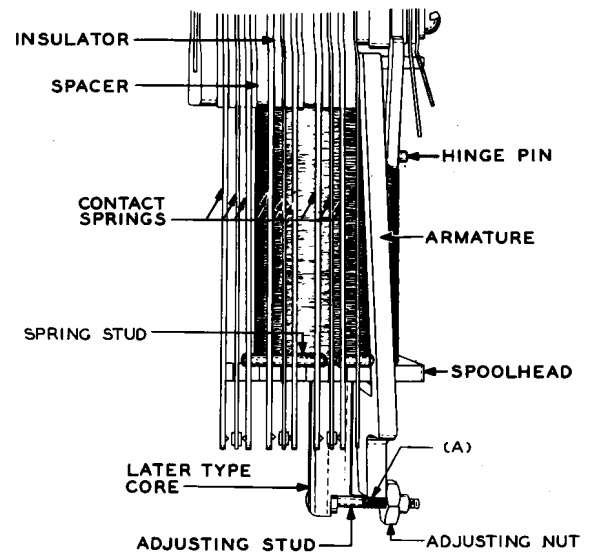

Fig. 5—Y-Type Relay—Top View

2.08 Adjusting Nut Tightness: On a relay having an adjusting stud, the adjusting nut shall be sufficiently tight on the stud to prevent its being turned with a torque of 3 ounce-inches.

To check this requirement, attempt to turn the adjusting nut with the thumb and forefinger. In case of doubt, this may be checked by the use of the 474A wrench and the 70D gauge. With the wrench on the nut, the gauge shall be applied in

the hole in the free end of the wrench, and the nut shall not turn when a pressure of 40 grams is applied at right angles to the wrench in clockwise direction as shown in Fig. 6.

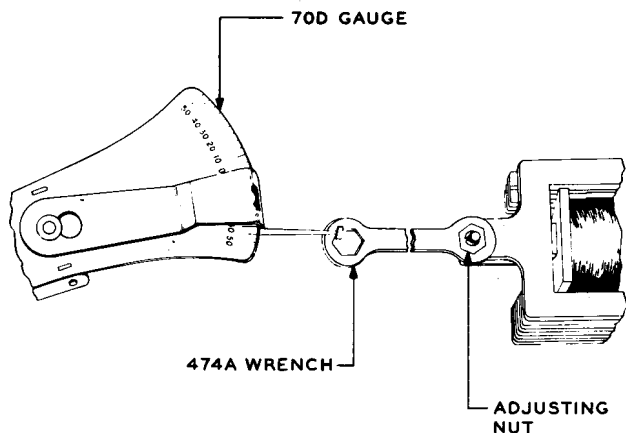

Fig. 6—Method of Checking Tightness of Adjusting Nut

2.09 Application of D-167911 Magnetic Separators: Fig. 7

(a) Some Y-type relays have high residual magnetism which may introduce difficulties in adjusting them to meet their electrical requirements. Magnetic separators per D-167911, when applied to a relay, change the residual characteristics and permit satisfactory adjustment. When used these separators shall be considered as part of the core. Separators should be used only after turnover and when one or both of the following conditions are present.

- (1) Excessive spring tensions required to meet the release requirement.
- (2) The spring tensions (within specified requirements) required to meet the release cause the armature to hesitate perceptibly in its travel when the specified operate current is applied.

(b) D-167911 separators when applied shall rest flat and snugly against the pole face of the core. Separators shall be clean and free from cracks or wrinkles.

(c) The coiled and flattened ends of the separator at the left of the core shall lie snugly against the core and shall be free of cracks.

(d) There shall be no appreciable clearance between the core and the separator as shown in Fig. 7(A).

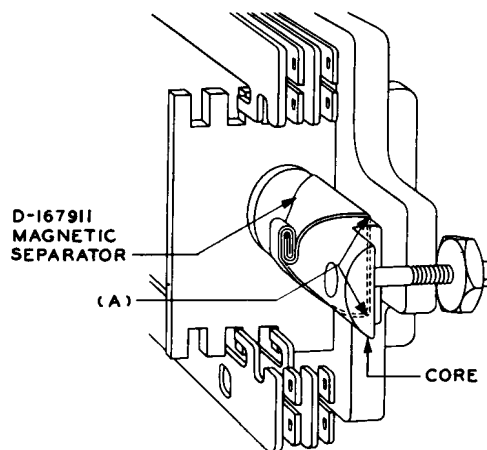

Fig. 7—Application of D-167911 Magnetic Separator

2.10 Armature Position: Fig. 1(C) and 8(A)—Both legs of the armature shall bear against the hinge bracket with the relay in the operated position and shall also bear against the hinge bracket after the relay has released.

Operate the relay electrically and gauge by eye.

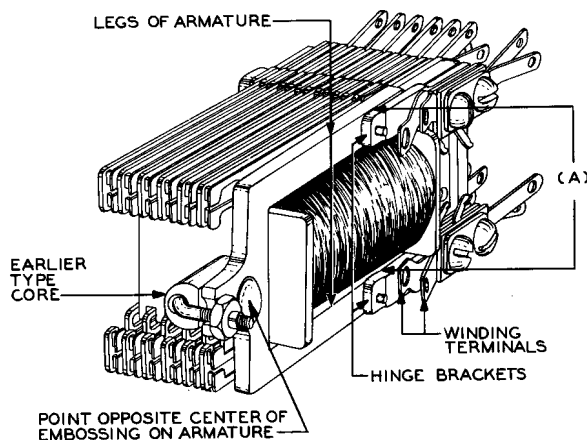

Fig. 8—Y-Type Relay—General View

2.11 Armature Travel: Fig. 9(A)—The armature travel shall be in accordance with the value specified for the relay in the armature travel column on the circuit requirements table. Unless otherwise specified, the armature travel tolerance shall be +0.003 inch.

Use the 131A gauge.

To check the armature travel requirement, as shown by Fig. 9, test the armature to core gap with gauges having a thickness both equivalent to and +0.003 inches greater than the specified armature travel. The gauge having the specified thickness should enter with at most a slight drag, whereas the +0.003-inch gauge may enter with a slight drag or not at all. Do not force the gauge.

2.12 Spring Tension

(a) The tension of each spring measured in grams shall be in accordance with the information given on Fig. 101 through 350, which is referred to in the BSP Fig. No. column of the circuit requirements table. The values given are to be used when the letter H appears in the Cont Pressure column of the circuit requirements table. Where SPL appears in the Cont Pressure column of the circuit requirements table, the spring tensions, contact make, and break contact

pressure shall be as specified herein for H contact pressure, except as modified by notes on the circuit requirements table.

(b) The springs shall be tensioned toward the armature. Unless the abbreviation Arm. Opr is shown associated with an arrow mark leading to a spring, the tension shall be measured with the armature in the unoperated position. A spring tensioned against the spoolhead shall register the required tension just as the tang of the spring leaves the spoolhead. A spring whose contacts are tensioned against the contacts of an opposing spring shall register the required tension just as the contact breaks. A spring tensioned against a stud shall register the required tension just as it leaves the stud. A spring tensioned against another spring or against the armature through a stud shall register the required tension just as the stud leaves the other spring or the armature. Use the 70H or the 70J gauge to check the tension. Apply the gauge so the tip of the gauge engages both prongs of the bifurcated springs as indicated in Fig. 10. When gauging tensions on solid springs, apply the tip of the gauge near the front end of the spring just in front of the contacts.

(c) A Springs

(1) Where the letter A appears associated with a particular spring, it means that

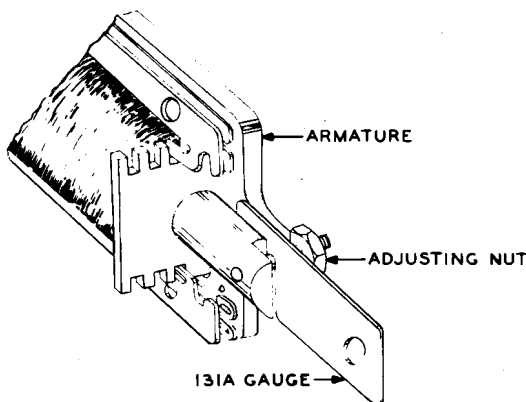

Fig. 9A—Relay Having Adjusting Stud

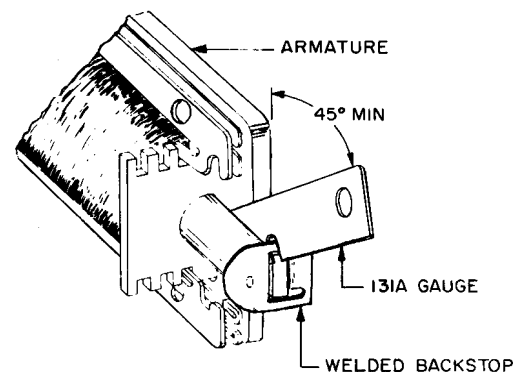

Fig. 9B—Relay Having Welded Backstop

Fig. 9—Position of Gauge When Checking Armature Travel

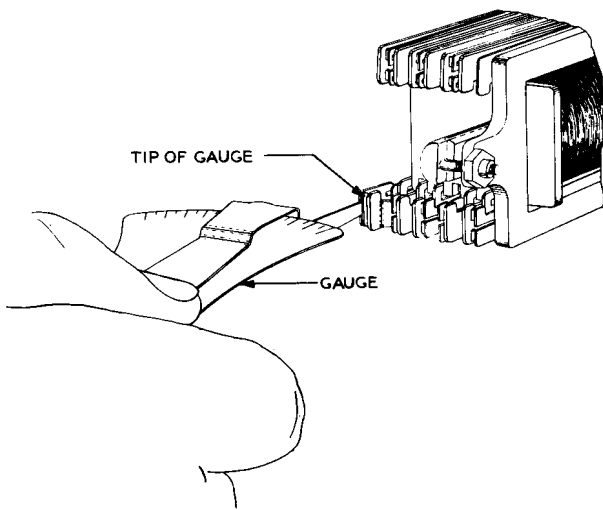

Fig. 10—Method of Checking Spring Tension

this spring need have no definite tension but shall be tensioned *toward* the armature. When the A springs are tensioned *against* the armature either directly or indirectly through studs, the tensions of all such A springs on the relay, together with the tension of any D springs that may also be similarly tensioned against the armature, shall hold the armature against the adjusting nut with sufficient pressure to insure that requirement 2.14 is met.

(2) Where the relay is equipped with a pin-type armature, the tension in one spring combination shall not be more than 2-1/2 times that in the other spring combination. To check this pressure on relays equipped with either a pin- or spring-type hinge, block the armature unoperated using the 768A armature blocking tool. Check the pressure of the stud against the armature by applying the 70H or the 70J gauge to the spring nearest the armature. Apply the tip of the gauge just in front of the stud.

Note: That part of the requirement which specifies that all A springs are to be tensioned toward the armature is met for test purposes if there is no stud gap present at the springs for which no stud gap is specified. For example, in spring combination 123 no stud gap should be present on either side of spring 4 and in spring combination 172 no stud gap

should be present on either side of spring 4 or between spring 7 and the stud on spring 6. Where a D spring is present, this requirement shall be met with the D spring lifted off its associated stud.

(d) **B Springs:** Where the letter B appears associated with a particular spring, it means that this spring together with the tensions of any A and D springs which may in turn be tensioned against it shall have a combined tension of

Test: Min 18 grams

Readjust: Min 20 grams

Use the 70H gauge applied to the B spring.

Example: On Fig. 141 the B tension specified for spring 7 is the combined tension of springs 2, 5, and 7 and is checked by applying the gauge to the tip of spring 7.

(e) **Buffer Springs**

(1) Buffer springs designated X' (in association with a second letter to indicate adjustment) on Fig. 101 through 350 are provided on certain relays to aid in meeting the electrical requirements. Where the letter F appears associated with a buffer spring, this buffer spring shall be used only in case spring tension, in addition to that provided by the other springs, is required to meet the specified release current flow requirements. On relays equipped with F buffer springs in both spring combinations, either or both buffer springs shall be used as required for the individual relay.

(2) The tension of each X' buffer spring designated F used shall be

Test: Min 20 grams

Max 100 grams

Readjust: Min 25 grams

Min 100 grams

Use the 70H or the 70J gauge applied to the tip of the spring.

2.13 Position of X' Buffer Springs Designated F

(a) Each X' buffer spring designated F used in meeting of the release electrical requirement shall meet the following requirements.

- (1) **Readjust Only:** When the relay is electrically energized against a 0.013-inch gauge inserted in the armature gap, there shall be a perceptible stud gap at the stud which operates the buffer spring.

Use the 131A gauge.

- (2) When the relay is electrically energized against a gauge inserted in the armature gap, there shall be no stud gap at the stud which operates the buffer spring.

Test: 0.004 inch

Readjust: 0.006 inch

Use the 131A gauge.

- (b) If an X' buffer spring designated F is not used, there shall be a stud gap at the stud which operates the buffer spring when the relay is electrically operated.

Gauge by eye.

2.14 Armature Back Tension: Fig. 11(A)—The armature shall be held against the backstop with a pressure of

Test: Min 18 grams

Readjust: Min 22 grams

Use the 70H or the 70J gauge applied to the back of the armature at a point opposite the center of the embossed surface as indicated in Fig. 11.

2.15 Spring Stud Clearance: Fig. 12(A)—The spring studs shall clear the springs through which they pass in all positions of the armature travel.

Gauge by eye.

2.16 Straightness of Springs: All springs, other than pretensioned springs (see 1.10 and 1.11), shall be free of sharp bends or kinks due to adjustment except that, in the case of thin (0.013 or 0.018 inch) springs, a kink may be permitted provided it is within 1/4 inch from where the

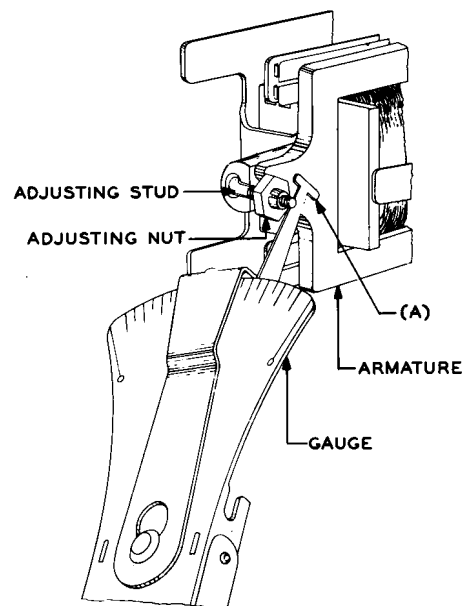

Fig. 11—Method of Checking Armature Back Tension

spring leaves the insulators. A gradual bow in a spring is permissible.

Gauge by eye.

2.17 Separation Between Springs: Fig. 12(B)—The clearance between adjacent springs whether in the unoperated or the electrically operated position of the relay shall be

Min 0.008 inch

Gauge by eye.

2.18 Stud Gap: Fig. 12(C)

- (a) **Stud Gaps Designated T:** With the relay unoperated, the clearance between the stud and the spring at the points designated T on Fig. 101 through 350 shall be

Min 0.006 inch

This requirement is met if there is a clearance between the spring and the stud with the 133A gauge inserted between the armature and the end of the stud which rests against the armature.

Gauge by eye.

(1) The use of the 510C test lamp equipped with the 561A straight tip or the 562B curved tip to illuminate the stud gap will facilitate gauging this requirement. Do not attempt to check the stud gaps by moving the armature toward the core manually since, when the armature is released, it may not restore to its position against the front ends of the yoke, thus causing false contact operation. To check the stud gaps, place the 510C test lamp so the gap is illuminated on the side away from the eye, and sight through the stud gap toward the light as shown in Fig. 13 or 14, depending upon whether the straight or curved tip is used.

(b) **Stud Gaps Designated S:** With the relay unoperated, there shall be a slight clearance between the spring studs and the spring at the points designated S [See (a)(1).]

Gauge by eye.

(c) **Stud Gaps Designated R:** With the armature moved toward the core so the make contacts designated P are just making with at least one pair of contacts, there shall be a slight clearance between the spring studs and the springs at the points designated R on Fig. 101 through 350. When contacts designated P are present in both top and bottom spring combinations of the relay, the corresponding stud gaps designated R shall be present when **both** P contacts have closed with at least one pair of contacts each. [See (a)(1).]

Gauge by eye.

2.19 Contact Make

(a) Both contacts on the bifurcated spring shall make with their associated contacts with the relay in the electrically operated position for normally open contacts and in the unoperated position for normally closed contacts.

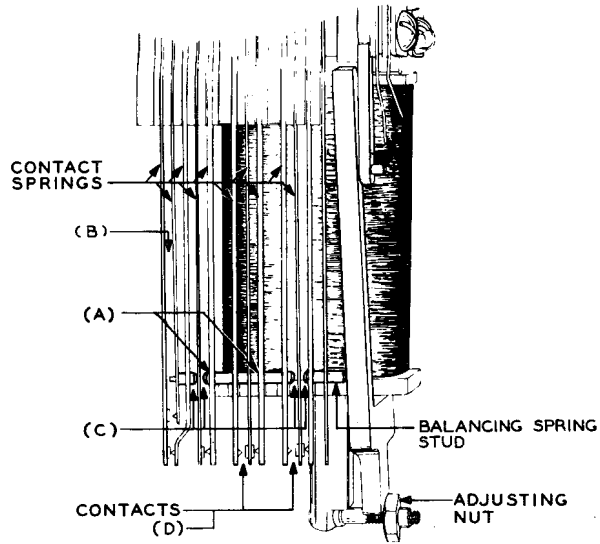

Fig. 12—Y-Type Relay—Top View

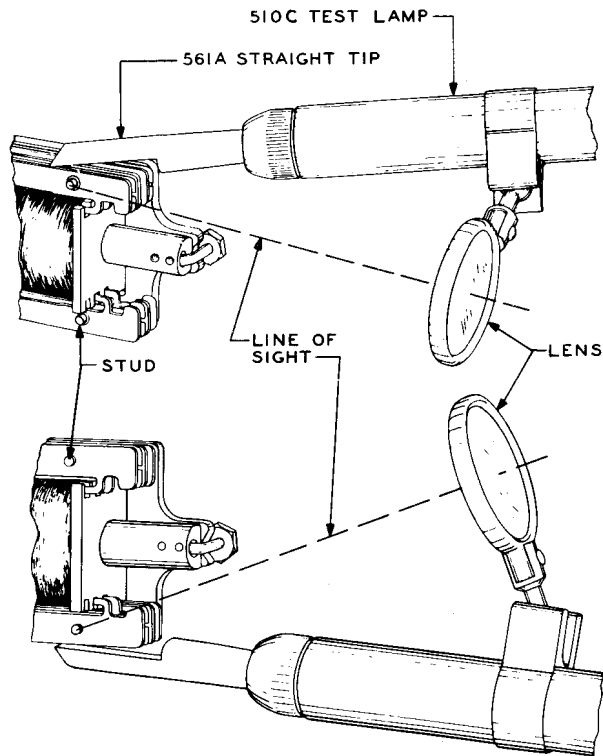

Fig. 13—Method of Gauging Stud Gap Using the 561A Straight Tip

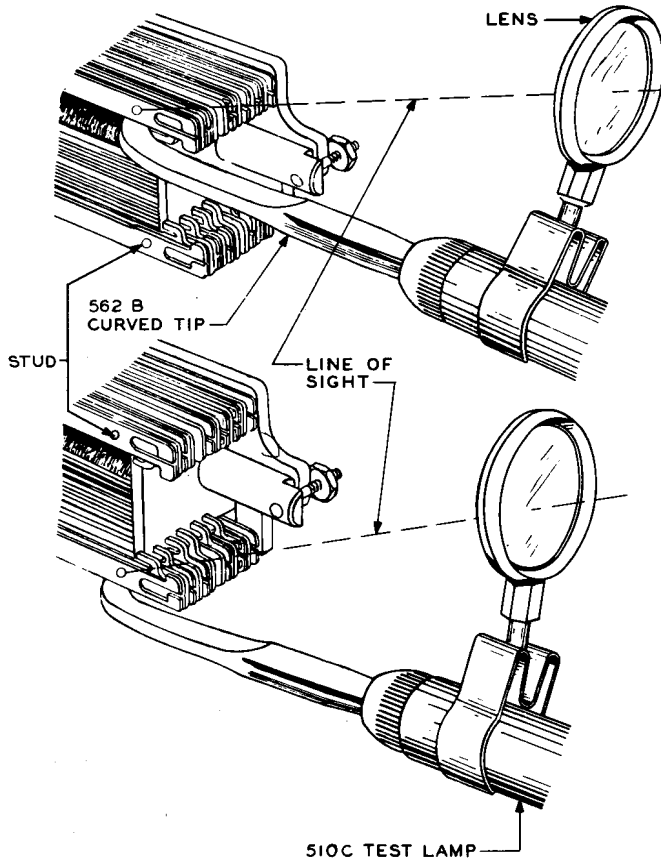

Fig. 14—Method of Gauging Stud Gap Using the 562B Curved Tip

Gauge by eye and feel.

(b) With the relay electrically energized against a gauge of the thickness indicated below inserted in the armature gap, normally open contacts shall meet the following conditions.

CONTACTS	CONTACTS SHALL NOT MAKE	AT LEAST ONE PAIR OF CONTACTS SHALL MAKE
All contacts except those designated J, K, M, and U	<i>Test</i> 0.018 inch <i>Readj</i> 0.015 inch	<i>Test</i> 0.008 inch <i>Readj</i> 0.010 inch
Contacts designated K	<i>Test</i> No reqt <i>Readj</i> No reqt	<i>Test</i> 0.013 inch <i>Readj</i> 0.015 inch
Contacts designated J and U	<i>Test</i> No reqt <i>Readj</i> No reqt	<i>Test</i> No reqt <i>Readj</i> No reqt
Contacts designated M	<i>Test</i> No reqt <i>Readj</i> No reqt	<i>Test</i> 0.008 inch <i>Readj</i> 0.010 inch

Use the 131A gauge.

(1) To check that the requirement is met, operate the relay electrically. Release the relay and insert a 131A gauge of the proper thickness in the armature gap, taking care that the long axis of the gauge is in the position as shown in Fig. 9. Energize the relay and note whether the contacts close. In case of doubt as to whether a contact is closed, apply the KS-6320 orange stick to the tip of the solid spring and attempt to move the spring *toward* its associated contact spring as indicated in Fig. 15. A perceptible movement of the solid spring without a corresponding movement of the bifurcated spring indicates that the contact is not closed. In case of doubt as to whether the requirement is met, release and reoperate the relay with the gauge in place and recheck for contact closure as covered above.

(2) When the circuit requirements table specifies insulating individual contacts on the relay being tested or adjusted, it will be satisfactory, when checking for contact make, to remove the insulating paper when checking the individual contact. In this case it may be necessary to open the contact manually using the KS-6320 orange stick to release the relay.

(c) **Readjust Only (After Turnover):** Whenever a particular contact requires cleaning or buildup removal or when readjustments are made on a contact spring, the following requirement shall be met, in addition to (b), on the contacts affected by the cleaning or the adjustment.

(1) **Normally Open Contacts:** Both contacts on the bifurcated spring shall make when the relay is energized against a 0.004-inch gauge inserted as covered in (b).

Use the 131A gauge.

(2) **Normally Closed Contacts:** Both contacts on the bifurcated spring shall break with their associated contacts at approximately the same time. Operate the relay manually.

Gauge by eye.

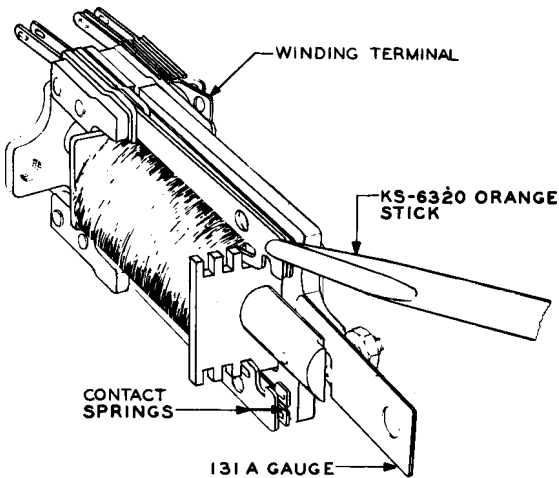

Fig. 15—Method of Checking Contact Make

2.20 Contact Separation: Fig. 12(D)

(a) Unless otherwise specified, the separation between each pair of contacts normally open or between each pair of contacts that are opened when the relay is electrically operated shall be

Min 0.005 inch

Gauge by eye.

On normally closed contacts, the requirement is met if the contacts break when the relay is electrically energized against a 0.004-inch blade of the 131A gauge inserted into the armature gap.

To check contact separation on relays on which the contacts are pitted, move the spoolhead spring manually toward its associated spring. A perceptible movement of the spring (at least 0.005 inch) before the contacts make indicates a satisfactory minimum contact separation.

(b) **Contacts Designated U:** The contact separation of the normally open contacts designated U on Fig. 101 through 350 shall be

Min 0.010 inch

Use the 134A gauge as shown in Fig. 16.

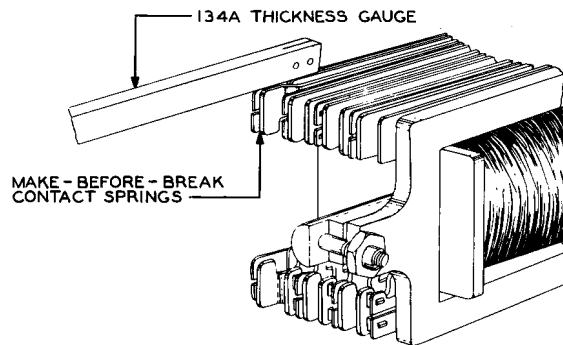

Fig. 16—Method of Gauging Contact Separation on Make-Before-Break Units

2.21 Contact Sequence: Fig. 17—With the exception of the E and H spring units, the break contacts of spring units equipped with make and break contacts as shown in Fig. 17 shall break before any make contact makes. On E and H units, the make contacts shall make before the break contact breaks.

Gauge by eye.

Note: There is no sequence between the break contacts of J unit nor between the make contacts of K unit; however, there is a sequence between the make contacts of F unit.

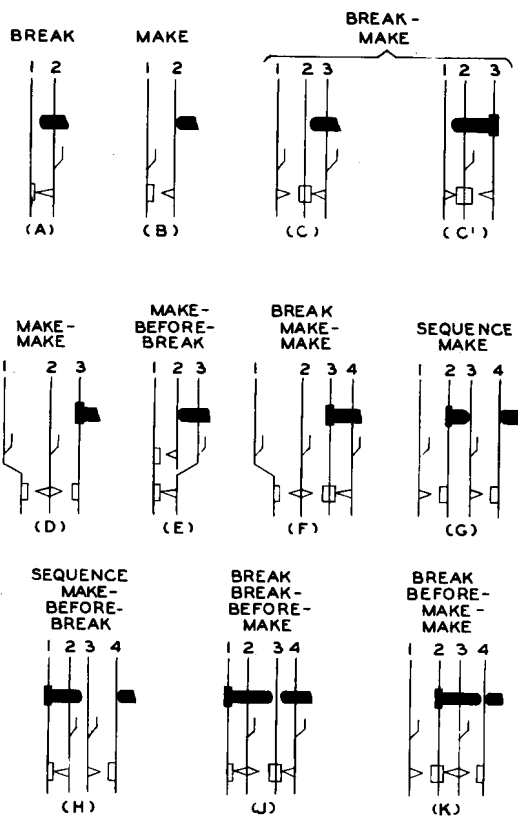

Fig. 17—Units of Relay Spring Combinations

2.22 Electrical Requirements

- (a) The relay shall meet the electrical requirements specified on the circuit requirements table.
- (b) The required release times for Y-type relays are obtained by adjusting them to meet hold and release current flow requirements.

Note 1: A hold requirement is considered met if, after the relay has operated and the current is reduced abruptly to the specified hold value, the armature remains in its operated position for at least 2 seconds. This interval may be judged satisfactorily by saying "one hundred and fifty-five" pronouncing each syllable fully and distinctly.

Note 2: A release requirement is considered met if, after the current is reduced to the specified release value, the relay releases in not more than 1 1/2 seconds. The interval may be judged satisfactorily by saying "one

hundred and one" pronouncing each syllable fully and distinctly.

(c) Since the current flow values are necessarily low, magnetic interference from adjacent relays has a critical effect on the adjustment. When the following note appears on the circuit requirements table, "Adjacent relays shall not be energized. See BSP," the adjacent uncovered relays as discussed herein shall not be energized. In this case all the electrical requirements shall be met under the following conditions.

- (1) The cover removed from the relay.
- (2) The horizontal magnetic shields (if provided) removed from above and below the relay.
- (3) Individual or common covers (if provided) removed from relays directly above and below the relay. (This applies to E-, U-, and similar-type relays.)
- (4) Adjacent uncovered relays as defined in Fig. 18 are not energized, except as noted below.

Note: A relay may be considered not energized if, without mechanical blocking, its armature remains against the adjusting nut.

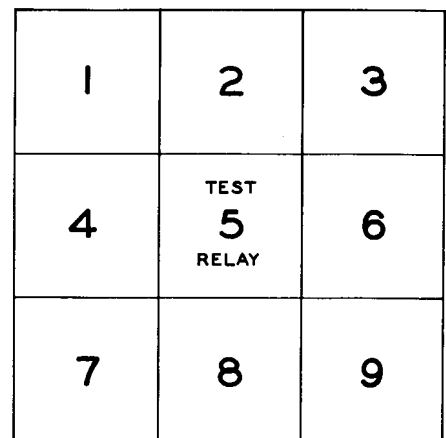

Fig. 18—Position 5 Indicates Relay Under Test—Positions 1,2,3,4,6,7,8, and 9 Indicate Adjacent Relays to Be Considered When Testing or Readjusting Y-Type Relays

SECTION 040-522-701

(5) Where the relay under test (position 5 as shown in Fig. 18) is equipped with an individual magnetic shield (flat metal plate mounted at right of relay), the uncovered adjacent relays in positions 3, 6, and 9 may be energized. Also, when testing the relay in position 5, if the relay in position 4 is equipped with an individual magnetic shield, uncovered relays in positions 1, 4, and 7 may be energized.

(6) When adjacent relays on either side (positions 1, 4, and 7 or 3, 6, and 9) are

equipped with individual covers or vertical common covers, these covers need not be removed, except where necessary to permit the adjustment of the relay under test. When such covers are not removed, only the uncovered adjacent relays shall not be energized.

(7) If one or more positions adjacent to the relay under test (position 5 as shown in Fig. 18) are unequipped, the unequipped positions shall be disregarded.

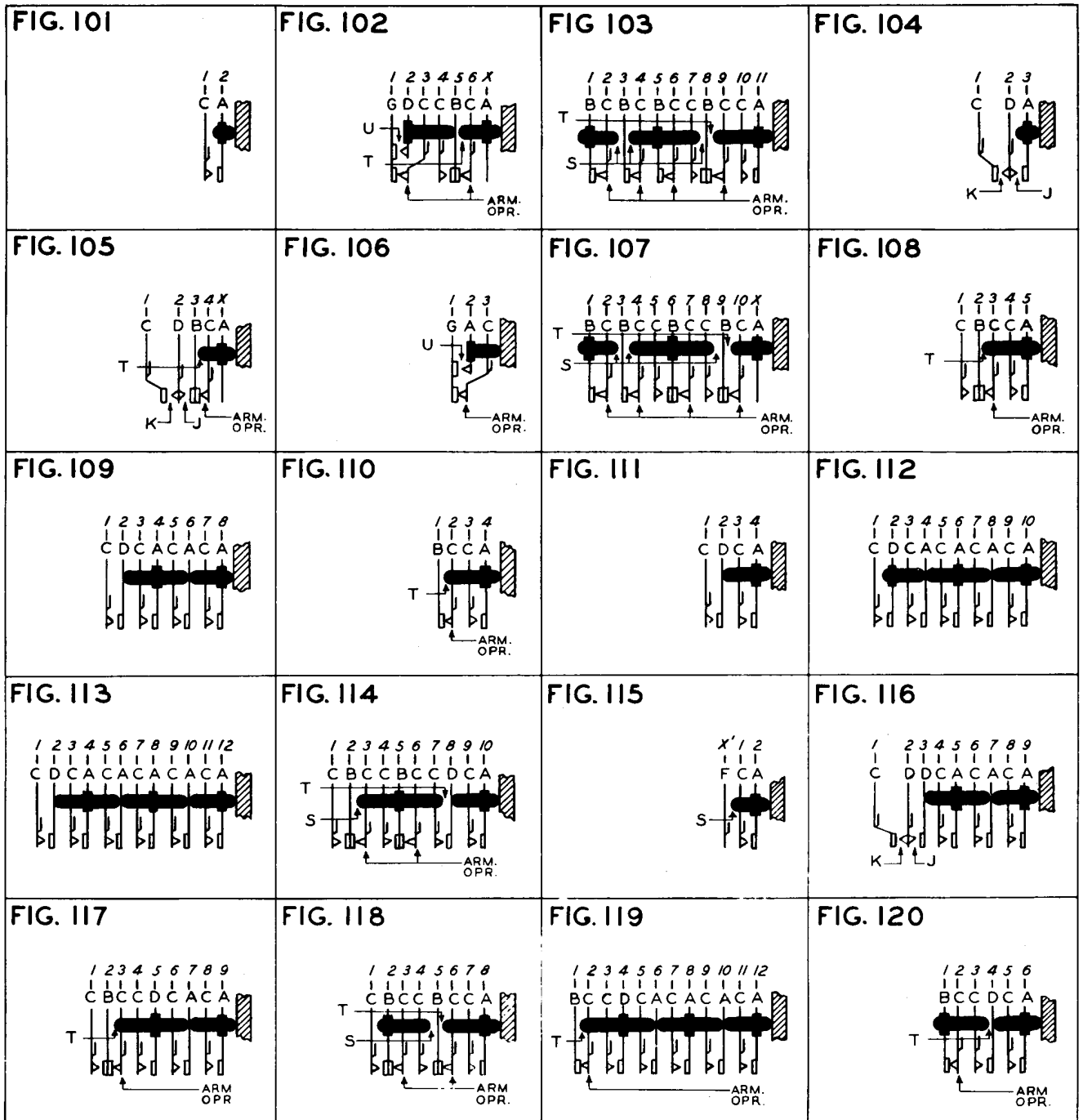

All Springs Tensioned Toward Armature
 Min Tension in Grams – H Cont Pressure

	TEST	READJ
A =	—	—
B =	—	—
C =	25	30
D =	5	6
F =	—	—
G =	35	40

See Reqt 2.12(c)
 See Reqt 2.12(d)
 See Reqt 2.12(e)

J, K, and U — See Reqt 2.19(b)
 T — Stud Gap — See Reqt 2.18(a)
 S — Stud Gap — See Reqt 2.18(b)
 μ — Spoolhead springs
 X — Balancing springs
 X' — Buffer springs

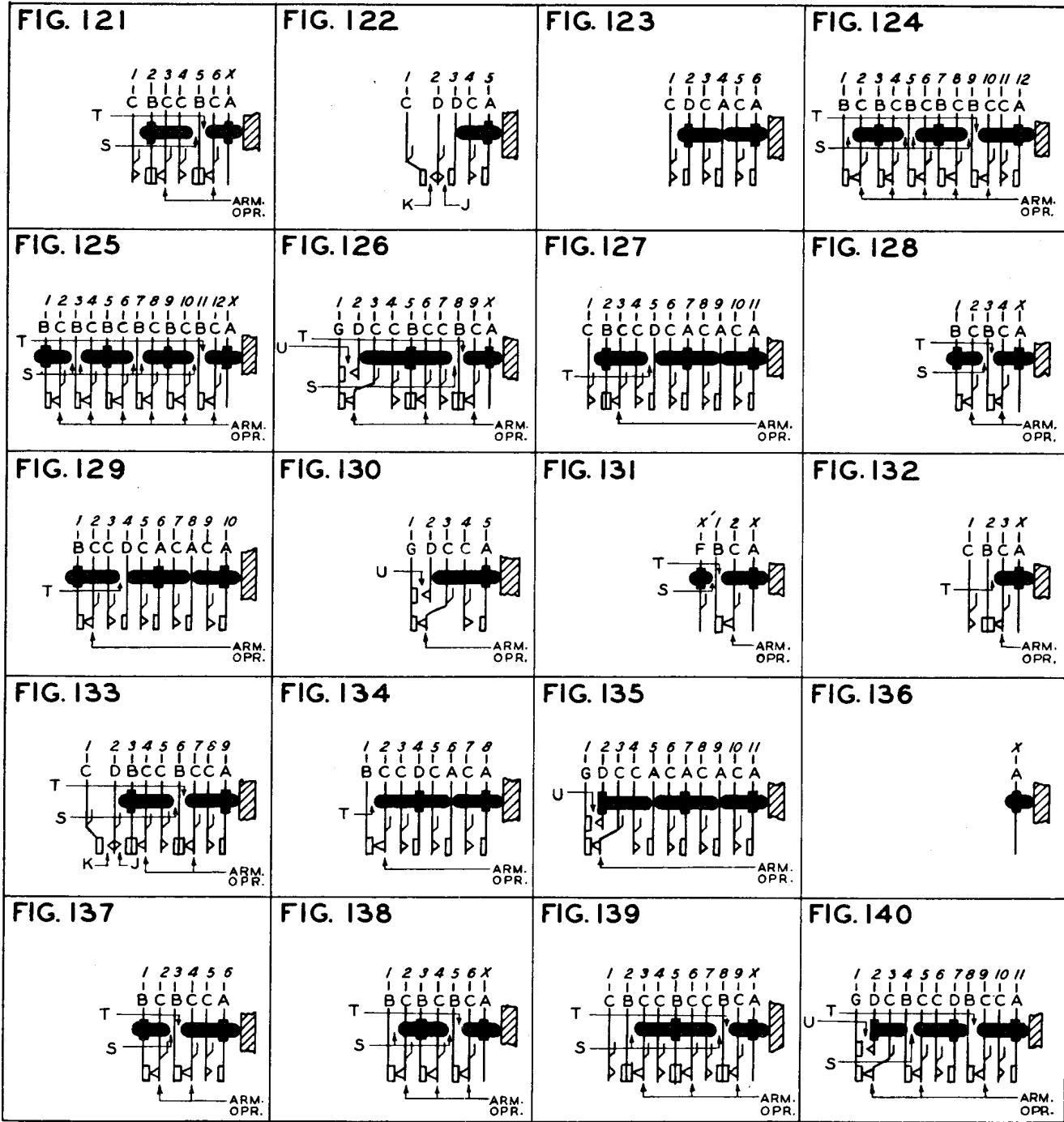

All Springs Tensioned Toward Armature
 Min Tension in Grams – H Cont Pressure

	TEST	READJ
A =	—	—
B =	—	—
C =	25	30
D =	5	6
F =	—	—
G =	35	40

See Reqt 2.12(c)
 See Reqt 2.12(d)
 See Reqt 2.12(e)

J, K, and U — See Reqt 2.19(b)
 T — Stud Gap — See Reqt 2.18(a)
 S — Stud Gap — See Reqt 2.18(b)
 μ — Spoolhead springs
 X — Balancing springs
 X' — Buffer springs

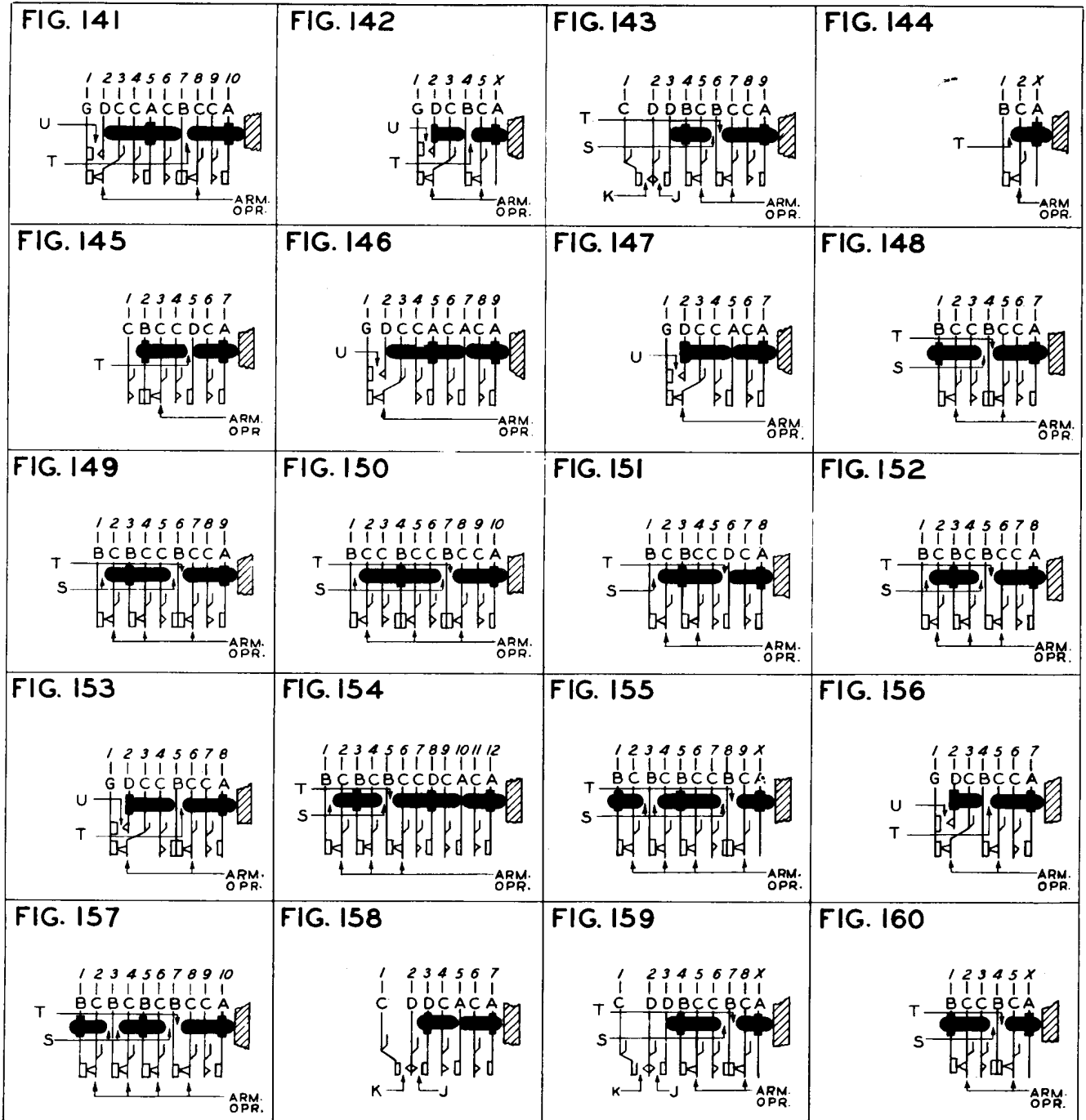

All Springs Tensioned Toward Armature
 Min Tension in Grams – H Cont Pressure

	TEST	READJ
A =	—	—
B =	—	—
C =	25	30
D =	5	6
F =	—	—
G =	35	40

See Reqt 2.12(c)
 See Reqt 2.12(d)
 See Reqt 2.12(e)

J, K, and U — See Reqt 2.19(b)
 T — Stud Gap — See Reqt 2.18(a)
 S — Stud Gap — See Reqt 2.18(b)
 μ — Spoolhead springs
 X — Balancing springs
 X' — Buffer springs

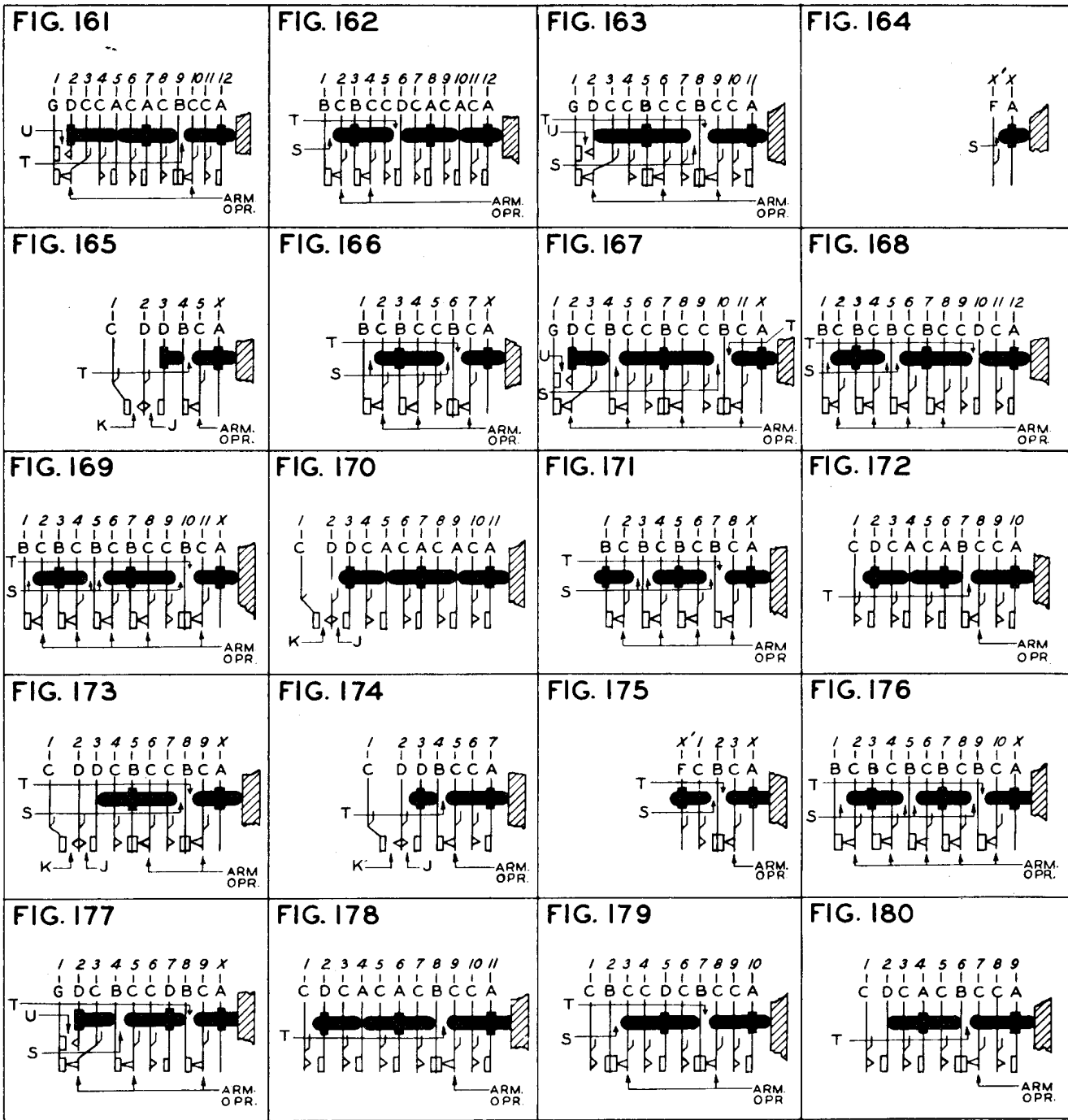

All Springs Tensioned Toward Armature
 Min Tension in Grams – H Cont Pressure

	TEST	READJ	
A =	—	—	See Reqt 2.12(c)
B =	—	—	See Reqt 2.12(d)
C =	25	30	
D =	5	6	
G =	35	40	

J, K, and U — See Reqt 2.19(b)
 T — Stud Gap — See Reqt 2.18(a)
 S — Stud Gap — See Reqt 2.18(b)
 μ — Spoolhead springs
 X — Balancing springs

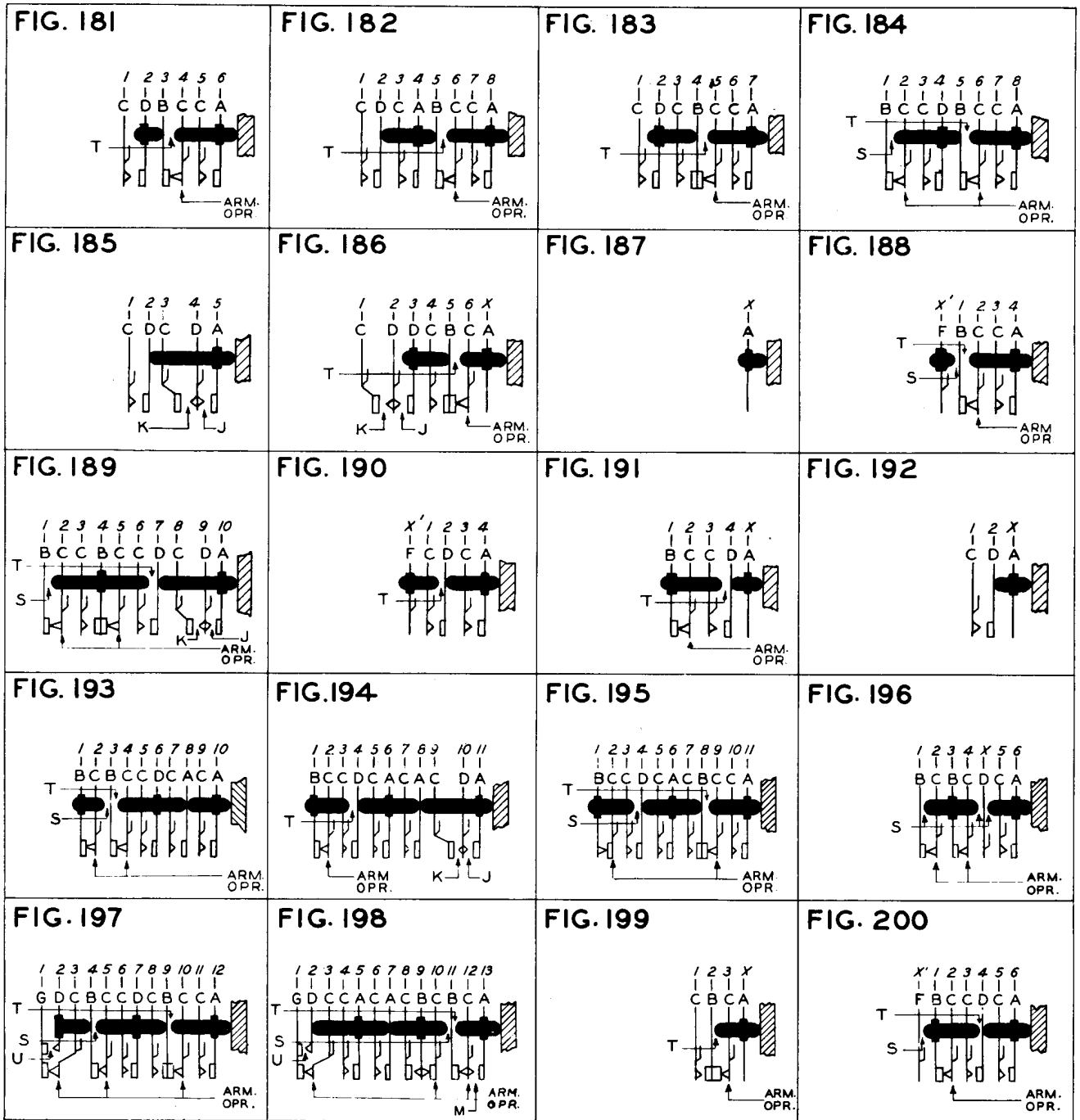

All Springs Tensioned Toward Armature
 Min Tension in Grams – H Cont Pressure

	TEST	READJ
A =	—	—
B =	—	—
C =	25	30
D =	5	6
F =	—	—
G =	35	40

See Reqt 2.12(c)
 See Reqt 2.12(d)
 See Reqt 2.12(e)

J, K, M, and U — See Reqt 2.19(b)
 T — Stud Gap — See Reqt 2.18(a)
 S — Stud Gap — See Reqt 2.18(b)
 μ — Spoolhead springs
 X — Balancing springs
 X' — Buffer springs

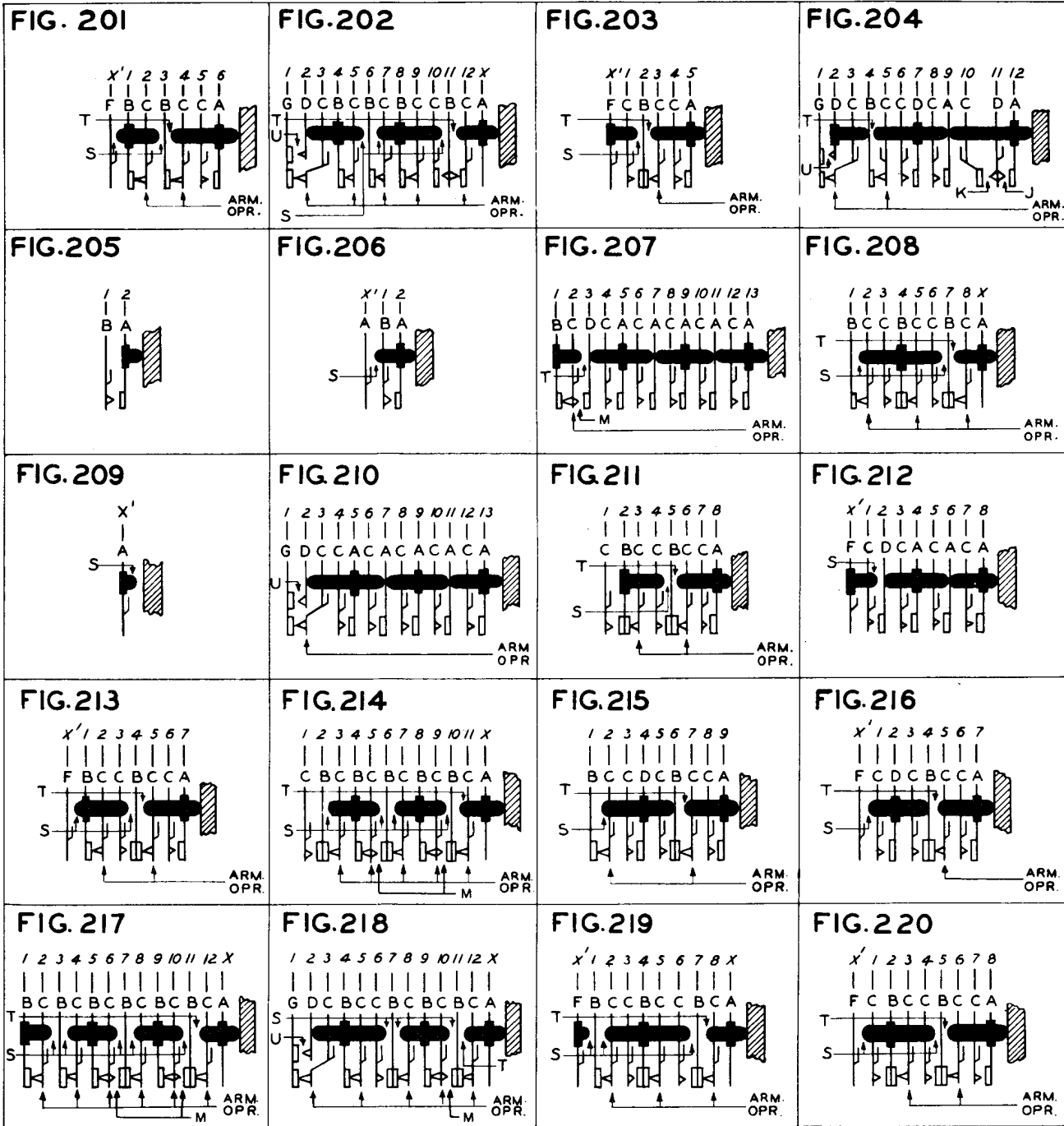

All Springs Tensioned Toward Armature
 Min Tension in Grams – H Cont Pressure

	TEST	READJ
A =	—	—
B =	—	—
C =	25	30
D =	5	6
F =	—	—
G =	35	40

See Reqt 2.12(c)
 See Reqt 2.12(d)
 See Reqt 2.12(e)

J, K, M, and U — See Reqt 2.19(b)
 T — Stud Gap — See Reqt 2.18(a)
 S — Stud Gap — See Reqt 2.18(b)
 μ — Spoolhead springs
 X — Balancing springs
 X' — Buffer springs

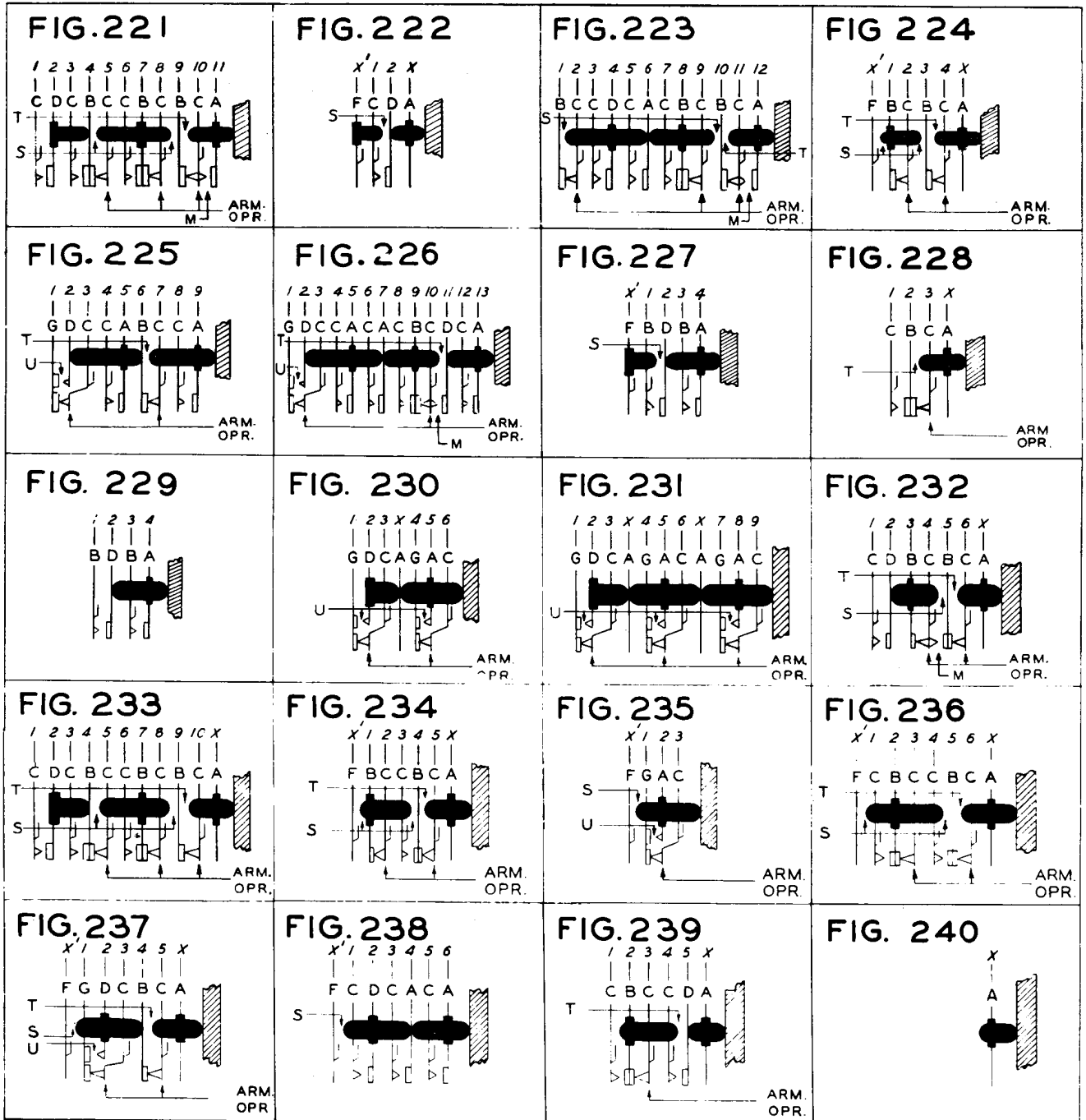

All Springs Tensioned Toward Armature
 Min Tension in Grams – H Cont Pressure

	TEST	READJ	
A =	—	—	See Reqt 2.12(c)
B =	—	—	See Reqt 2.12(d)
C =	25	30	
D =	5	6	
F =	—	—	See Reqt 2.12(e)
G =	35	40	

M and U — See Reqt 2.19(b)
 T — Stud Gap — See Reqt 2.18(a)
 S — Stud Gap — See Reqt 2.18(b)
 μ — Spoolhead springs
 X — Balancing springs
 X' — Buffer springs

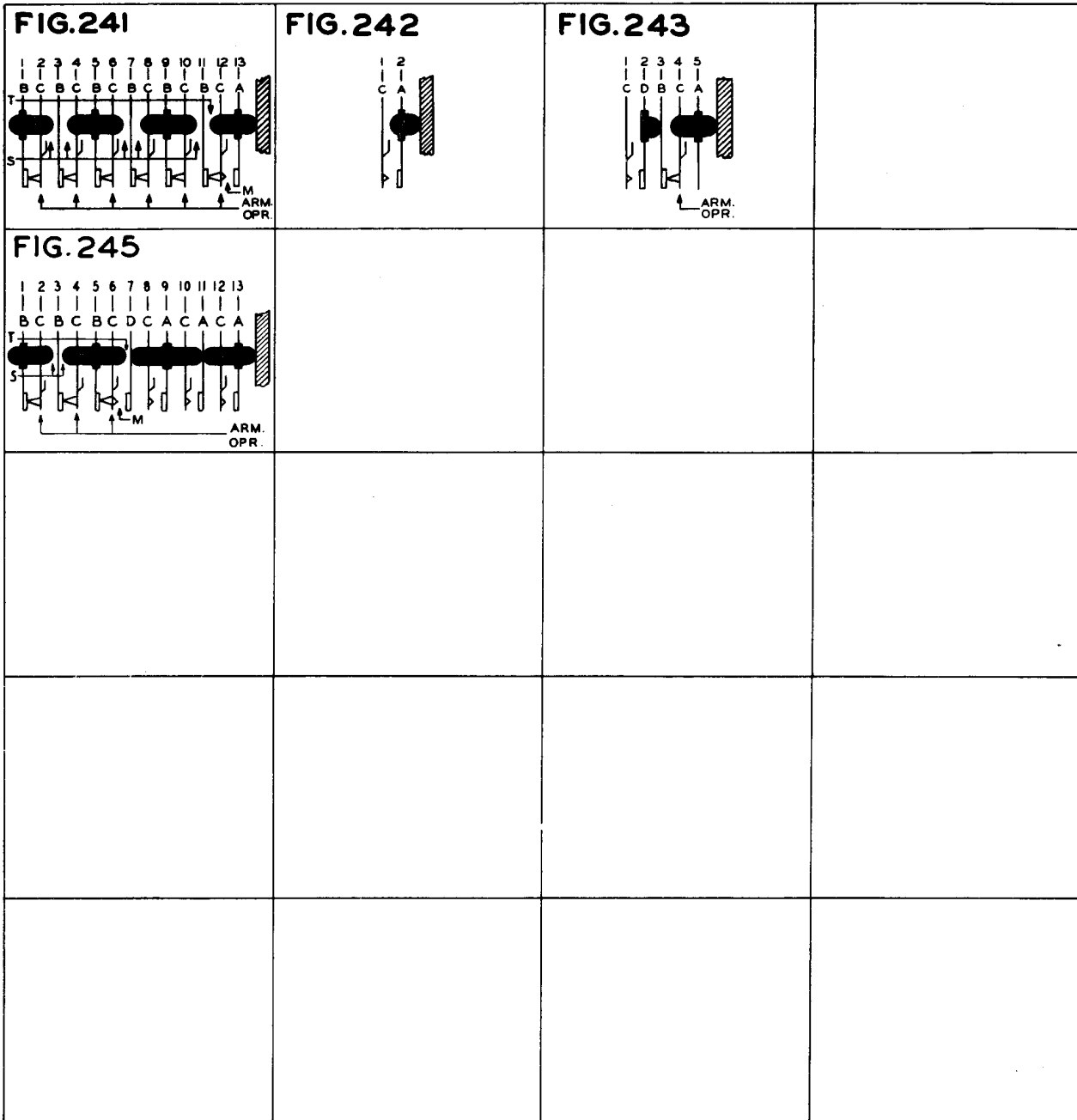

All Springs Tensioned Toward Armature
 Min Tension in Grams – H Cont Pressure

	TEST	READJ		
A =	—	—	See Reqt 2.12(c)	M — See Reqt 2.19(b)
B =	—	—	See Reqt 2.12(d)	T — Stud Gap — See Reqt 2.18(a)
C =	25	30		S — Stud Gap — See Reqt 2.18(b)
D =	5	6		μ — Spoolhead springs

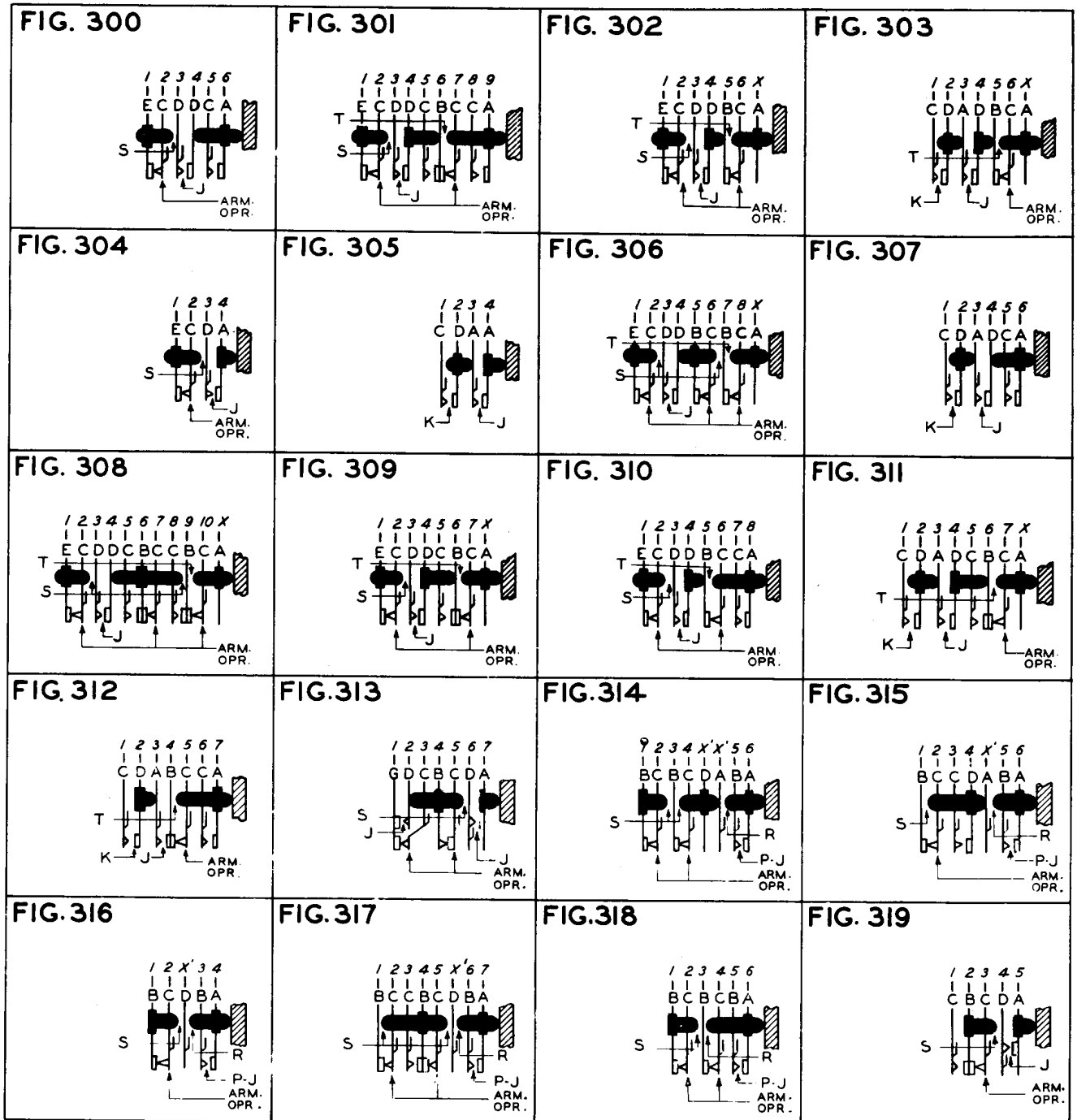

All Springs Tensioned Toward Armature
 Min Tension in Grams – H Cont Pressure

	TEST	READJ		
A =	—	—	See Reqt 2.12(c)	J and K — See Reqt 2.19(b)
B =	—	—	See Reqt 2.12(d)	T — Stud Gap — See Reqt 2.18(a)
C =	25	30		S — Stud Gap — See Reqt 2.18(b)
D =	5	6		P and R — Stud Gap — See Reqt 2.18(c)
E =	28	30		μ — Spoolhead springs
G =	35	40		X — Balancing springs
				X' — Buffer springs

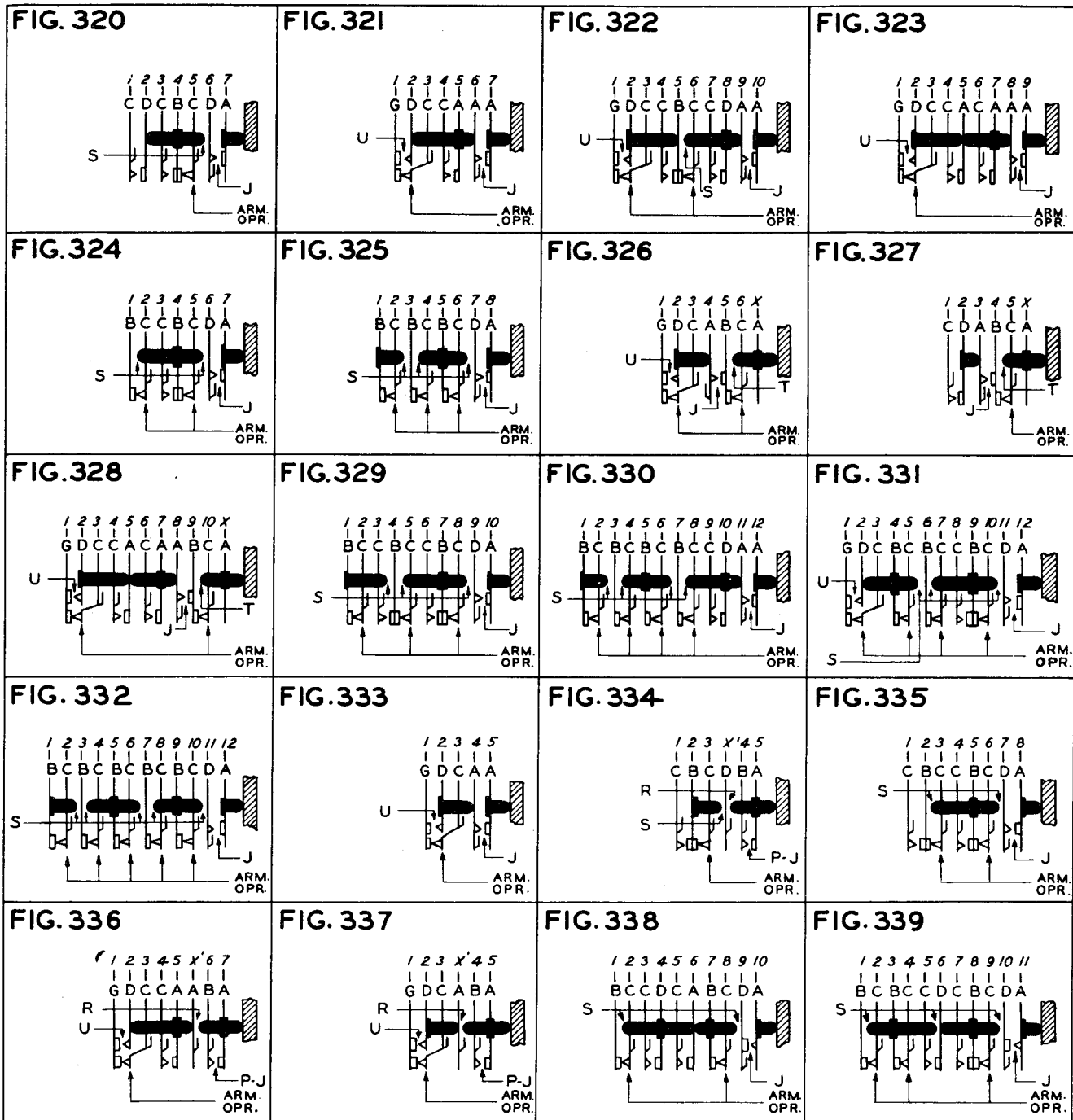

All Springs Tensioned Toward Armature
 Min Tension in Grams – H Cont Pressure

	TEST	READJ
A =	—	—
B =	—	—
C =	25	30
D =	5	6
G =	35	40

See Reqt 2.12(c)
 See Reqt 2.12(d)

J and U — See Reqt 2.19(b)
 T — Stud Gap — See Reqt 2.18(a)
 S — Stud Gap — See Reqt 2.18(b)
 P and R — Stud Gap — See Reqt 2.18(c)
 μ — Spoolhead springs
 X — Balancing springs
 X' — Buffer springs

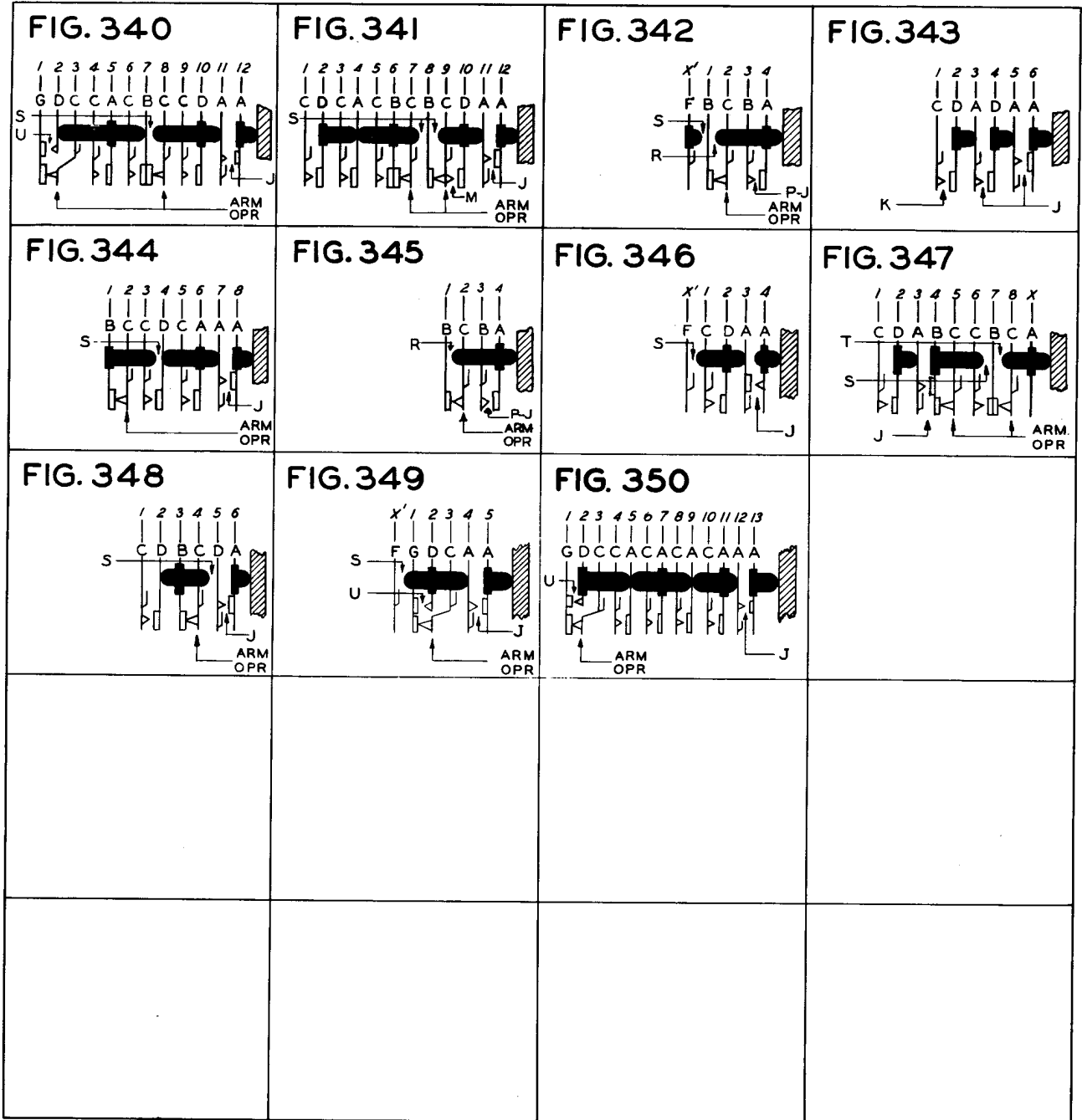

All Springs Tensioned Toward Armature
 Min Tension in Grams – H Cont Pressure

	TEST	READJ		
A =	—	—	See Reqt 2.12(c)	J, K, M, and U — See Reqt 2.19(b)
B =	—	—	See Reqt 2.12(d)	T — Stud Gap — See Reqt 2.18(a)
C =	25	30		S — Stud Gap — See Reqt 2.18(b)
D =	5	6		P and R — Stud Gap — See Reqt 2.18(c)
F =	—	—	See Reqt 2.12(e)	μ — Spoolhead springs
G =	35	40		X — Balancing springs
				X' — Buffer springs

SECTION 040-522-701

3. ADJUSTING PROCEDURES

3.001 *List of Tools, Gauges, Materials, and Test Apparatus*

CODE OR SPEC NO.	DESCRIPTION
TOOLS	
300	Spring adjuster
303	Spring adjuster
363	Spring adjuster
474A	3/16- by 1/4-inch hex. closed-end offset wrench
485A	Smooth-jaw pliers
505A	Spring adjuster (for 0.013-inch springs)
506A	Spring adjuster (for 0.018- and 0.023-inch springs)
507A	Spring adjuster (for 0.030-inch spring) (two required)
510C	Test lamp [Must be equipped with the 561A straight tip or the 562B curved tip and W2CB (24V) or W2BL (48V) cord.]
611A	Hinge bracket adjuster
612A	Relay core holder
671A	Magnetic separator adjuster (or the replaced D-167912 magnetic separator adjuster)
768A	Armature blocking tool
KS-6320	Orange stick
KS-21034	Stud cap applicator tool
KS-21258	Backstop adjuster
—	B scissors
—	3-inch C screwdriver

CODE OR SPEC NO.	DESCRIPTION
TOOLS	
—	4-inch E screwdriver
—	B long-nose pliers
—	Diagonal pliers
GAUGES	
70D	50-0-50 gram gauge
70H	0-30 gram gauge
70J	0-150 gram gauge
131A	Thickness gauge nest
133A	Stud gap gauge
134A	0.010-inch offset thickness gauge
MATERIALS	
D-167911	Magnetic separator
KS-14666	Cloth
P-10F137	0.009-inch cap
P-10F138	0.012-inch cap
P-10F548	0.006-inch cap
P-11A706	Armature plate (lower armature plate)
P-11A707	Armature plate (upper armature plate)
TEST APPARATUS	
35 type	Test set
<p>3.01 Cleaning: (Reqt 2.01)—Clean the contacts and other parts of the relay in accordance with the section covering cleaning and reconditioning relay contacts. After cleaning, check that requirement 2.19(c) is met and, if necessary, adjust as covered in 3.19.</p>	
<p>3.02 Relay Mounting: (Reqt 2.02)</p>	
<p>3.03 Vertical Clearance: (Reqt 2.03)—To tighten the mounting screws, use the 4-inch E screwdriver. To position the relay on the mounting</p>	

plate, slightly loosen the mounting screws of the relay affected and shift the relay as required. Tighten the screws securely, taking care that the relay is in proper alignment and that there is the specified clearance both above and below the relay.

3.04 *Cover Spring and Cover Guide Pressure and Cover Cap Tightness:* (Reqt 2.04)

- (1) If the cover spring does not rest on the spoolhead or if the cover is not held securely on the relay, adjust the spring with the 300 spring adjuster, applying it near the crook in the spring as shown in Fig. 19. If it is not possible to correct the condition in this manner, proceed as covered in (2).
- (2) Remove the relay from the mounting plate and remove the screws which hold the cover guide and cover spring in position using the 3-inch C screwdriver. Adjust the cover spring manually by bowing it at the crook in the spring. To adjust the cover guide after it has been removed, bend the part that is secured by the screws as required using the B long-nose pliers. Remount the cover guide and the cover spring and tighten the mounting screws securely.
- (3) If a metal cover cap does not fit properly, adjust the cover cap prongs as required using the B long-nose pliers.
- (4) If a plastic cover cap does not fit properly, replace the cap.

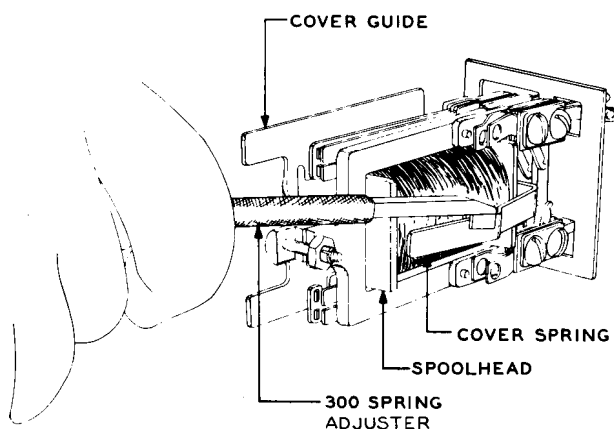

Fig. 19—Method of Adjusting Cover Spring Pressure

3.05 *Contact Alignment:* (Reqt 2.05)

3.06 *Spring Tang Position:* (Reqt 2.06)—If the contacts do not line up properly or if the tang does not overlap the spoolhead sufficiently, it is probably due to the springs having shifted in the assembly. In this case refer the matter to the supervisor.

3.07 *Adjusting Stud Clearance:* (Reqt 2.07)—If the armature rubs against the adjusting stud, grasp the adjusting nut with the B long-nose pliers and bend the adjusting stud as required. In this operation, exercise care not to damage the threads on the stud or to loosen the stud. If the stud cannot be adjusted to provide the proper clearance in this manner or if the stud is loose in the core, refer the matter to the supervisor.

3.08 *Adjusting Nut Tightness:* (Reqt 2.08)—To tighten loose adjusting nuts, back off the adjusting nut from the adjusting stud using the 474A wrench until its slotted portion is free of the stud. Then force the slotted parts of the nut closer together using the B long-nose pliers as shown in Fig. 20.

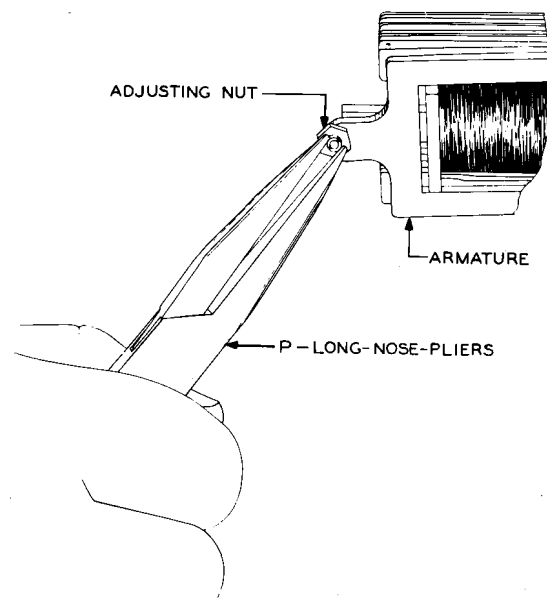

Fig. 20—Method of Tightening Adjusting Nut on Stud

3.09 Application of D-167911 Magnetic Separators: (Reqt 2.09)

(1) To place a D-167911 separator on the core, insert the long end in the armature gap from the top and pass it down between the core and the armature until the bend of the separator rests approximately on the top edge of the core pole face as shown in Fig. 21. With the front edge of the separator close to the adjusting stud or welded backstop, insert a 131A gauge of approximately 0.020-inch thickness in the armature gap as shown in Fig. 22 and electrically energize the relay. While holding the relay manually operated, disconnect the current from the relay, and leaving the gauge in place with the 485A pliers applied to the lower end of the separator, pull the separator downward until the bend of the separator fits snugly against the upper edge of the core pole face. Hold the separator in this position, and electrically energize the relay so the gauge presses the separator firmly against the core pole face. With the KS-6320 orange stick, bend the lower end of the separator around the lower end of the core so it clears the relay springs. Grasp the lower end of the separator with the 485A pliers, and pull it toward the left in line with the lower surface of the core, at the same time rubbing the separator with the flat end of the orange stick to shape it to the lower angle of the core pole face. Release the relay, and move the separator to the rear of the core pole face.

(2) Electrically energize the relay against the 131A gauge inserted in the armature gap. Shape the separator around the core with the orange stick and fingers so the two narrow bands come nearly together as shown in Fig. 22(A). Place the flat surface of the long point of the 671A magnetic separator adjuster against the underside of the bottom band of the separator, and press upward with the adjuster, at the same time pressing down on the upper band of the separator with a forefinger. When the two bands contact, push the adjuster forward so the two bands slide into the slot. Move the adjuster to the left until the length of the separator extending to the left of the adjuster is only slightly greater than the width of the adjuster as shown in Fig. 22. Hold the adjuster so both ends of the separator coincide, and bend the extreme tips of the separator which project through the adjuster downward with a finger or orange stick.

Then holding the adjuster horizontally in line with the core, move the handle of the adjuster slightly to the left so the side of the tapered end of the adjuster nearest the core is parallel to it and twist the adjuster in a clockwise direction until the ends of the separator are firmly wound together concentrically and the separator fits snugly all around the core as shown in Fig. 23. With the relay still energized, lift the gauge off the stud and with a rotary motion move it up and down between the armature and the separator two or three times to flatten out the entire surface of the separator against the pole piece. Again rotate the adjuster to insure that the separator is tight. Then hold the separator in place with a finger tip, and withdraw the adjuster. Flatten the convolutions of the separator with the 485A pliers as shown at Fig. 24(A); then fold the flattened convolutions of the separator in a clockwise direction with a finger or the orange stick against the rear of the core as shown in Fig. 24(B). Again rotate the 131A gauge. Release the relay and remove the gauge.

(3) When a separator has been added, recheck the relay for armature travel (2.11), stud gap (2.18), contact make (2.19), and contact separation (2.20) in addition to its adjustment for electrical requirements.

Note: If difficulty is experienced in meeting the electrical requirements, it may be due to a damaged or incorrectly applied separator.

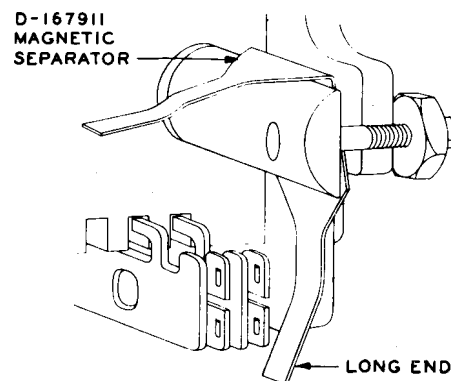

Fig. 21—Method of Inserting D-167911 Magnetic Separator in Armature Gap

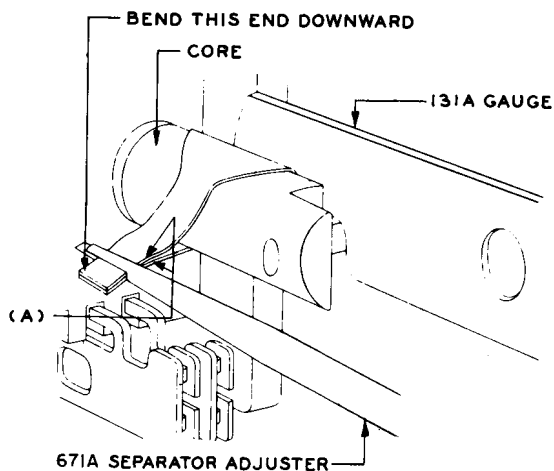

Fig. 22—Method of Using the 671A Separator Adjuster

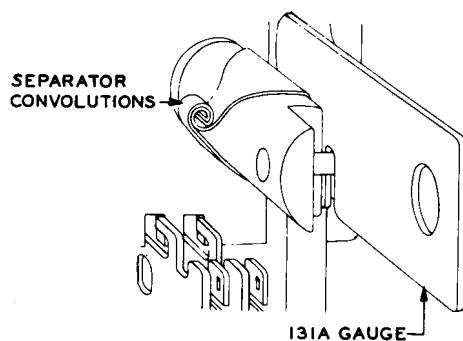

Fig. 23—D-167911 Separator Convolutions After Removal of 671A Separator Adjuster

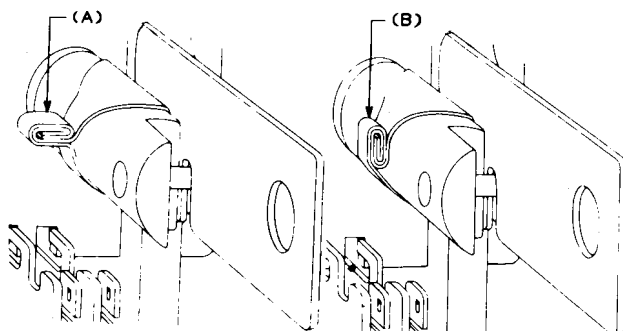

Fig. 24—Flattening of Separator Convolutions

3.10 Armature Position: (Req't 2.10)

(a) If the armature does not rest against the front ends of the hinge bracket after the relay has been electrically operated and released, check that the tensions of the A springs in the top and bottom spring combinations meet requirement 2.12 and, if they do not, adjust as covered in 3.12 through 3.17(7). If, when the relay is not energized, one leg of the armature leaves the bracket preventing the armature from returning to its unoperated position, the combined operated tensions of the springs in the top and bottom spring combinations are excessively unequal. In this case recheck the individual spring tensions, and readjust to more nearly equalize the top and bottom spring tensions. If, after making this adjustment the requirement is not met in both the operated and unoperated positions of the relay, it is an indication that the front ends of the hinge bracket are not properly positioned or that the armature spring hinges or the armature hinge pins are bent. In these cases refer the matter to the supervisor.

(b) Where the relay is equipped with hinge pins and the holes in the hinge brackets are worn so the armature rubs on the spoolhead, reposition the armature as follows. If the relay is equipped with a magnetic separator, insert the 3-inch C screwdriver between the convolutions of the separator and the core and pry the convolutions open. Remove the separator with the fingers. Slide the 612A relay core holder over the end of the core as far as possible. Then slide the 611A hinge bracket adjuster over the upper hinge bracket as far as possible so the adjuster is between the armature bracket and the winding terminal, and the hinge pin is in the hole in the adjuster. While holding the relay stationary with the holder, apply a slight upward pressure on the handle of the adjuster. Carefully bend the hinge bracket upward in this way until the armature clears the top edge of the spoolhead. Check that the armature also clears the bottom edge of the spoolhead. If the armature does not clear the bottom edge, bend the upper hinge bracket down slightly. Check that the electrical requirements are met. If the electrical requirements are not met, this may be due to the lower hinge pin binding in the associated hinge bracket. To correct this, bend the lower hinge bracket upward slightly

using the 612A holder and the 611A adjuster as described above.

Caution: Take care in making these adjustments to avoid bending the brackets more than necessary since this may weaken or break them. After completing the adjustments, make sure that the winding terminals on multiwinding relays are not shorted.

(c) Where the relay was equipped with a magnetic separator, mount a new magnetic separator on the core as covered in 3.09. If the armature cannot be satisfactorily repositioned as described in (b), refer the matter to the supervisor.

3.11 Armature Travel: (Reqt 2.11)

(a) **Relays Having Adjusting Stud:** To adjust the armature travel, insert the 131A gauge corresponding to the armature travel specified on the circuit requirements table in the armature gap as shown in Fig. 25. Take care that the long axis of the gauge is parallel with the horizontal center line of the core. Turn the adjusting nut with the 474A wrench until friction is felt against the gauge. Remove the gauge and check that requirement 2.08 is met.

(b) **Relays Having 0.032-Inch Thick Welded Backstop:** To adjust the armature travel, apply the 303 spring adjuster as shown in Fig. 25.

(c) **Relays Having 0.050-Inch Thick Welded Backstop:** To adjust armature travel, place the slot in the KS-21258 adjuster over the backstop and engage it to its full depth. Support the bend in the tool with the thumb and forefinger as shown in Fig. 25 so that torque applied causes the backstop to bend at the tool slot edge. Depending on the direction of adjustment, push or pull on the tool to prevent bending at the core edge or the weld.

- 3.16 **Straightness of Springs:** (Reqt 2.16)
- 3.17 **Separation Between Springs:** (Reqt 2.17)

(a) **Spring Tension**

(1) Spring tensions are specified on a minimum basis. They have, however, in the case of moving springs, a direct bearing on the electrical performance of the relay, and if they are greatly in excess of the specified minimum, the relay may fail to meet its electrical requirements in which case it will be necessary to reduce the tensions. Attempt to distribute the tensions of the moving springs

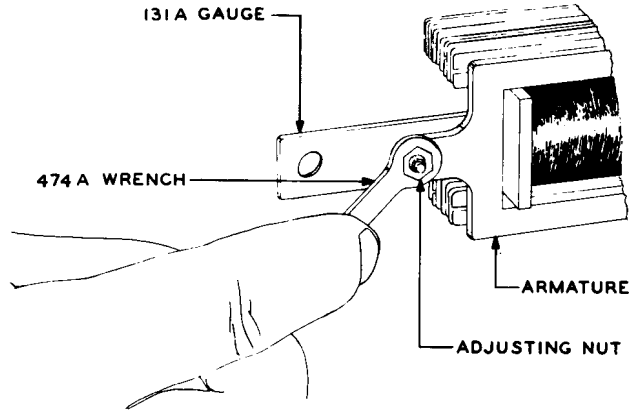

Fig. 25A—Relay Having Adjusting Stud

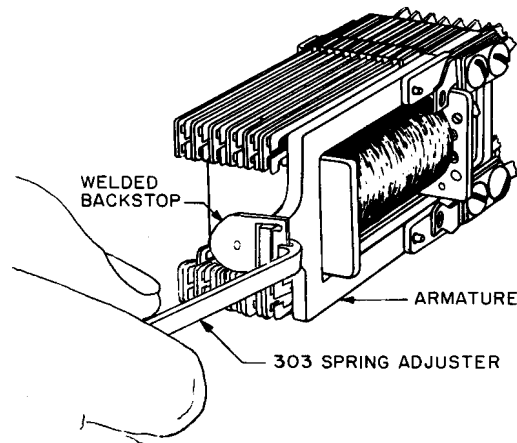

Fig. 25B—Relay Having 0.032-Inch Thick Welded Backstop

- 3.12 **Spring Tension:** (Reqt 2.12)
- 3.13 **Position of X' Buffer Springs Designated F:** (Reqt 2.13)
- 3.14 **Armature Back Tension:** (Reqt 2.14)
- 3.15 **Spring Stud Clearance:** (Reqt 2.15)

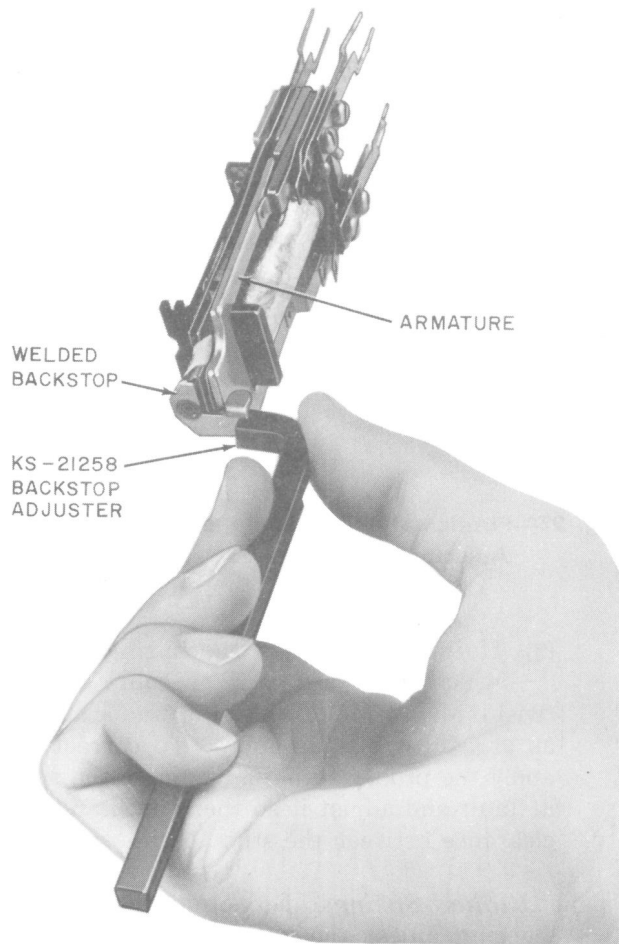

Fig. 25C—Relay Having 0.050-Inch Thick Welded Backstop

Fig. 25—Method of Adjusting for Armature Travel

proportionately between the top and bottom spring combinations.

- (2) To adjust the springs for tension, use the 505A spring adjuster for 0.013-inch springs, the 506A spring adjuster for 0.018- and 0.023-inch springs, and the 507A spring adjuster for 0.030-inch springs. It is especially important to use the 505A spring adjuster on

0.013-inch springs since the use of any adjuster having a wider slot may result in unsatisfactory adjustment and may affect the adjustment of the adjacent springs.

Pretensioned Springs (See 1.11 and 1.12.)

- (3) When the springs have been pretensioned, do not attempt to remove the bends as the adjustment will be destroyed. Exercise care not to slide or draw the spring adjuster over a bend in a pretensioned spring.

- (4) To adjust a pretensioned spring for tension, place the slotted portion of the spring adjuster against the spring to be adjusted on the side toward the mating spring just behind the contacts. Tilt the adjuster so it rests on the mating spring and, using this spring as a guide, slide the adjuster back to the base of the spring. Roll the adjuster over the spring to be adjusted so the spring fits into the slot in the adjuster. When adjusting a balancing spring or a buffer spring, use an adjacent spring as a guide. Adjust the spring to the right or left as required, taking care not to tilt the spring or disturb adjacent springs. If the requirements cannot be met in this manner, refer the matter to the supervisor.

- (5) If the studs touch the springs through which they pass, this may be due to a twist in the spring to which the stud is attached. To correct this, apply the proper spring adjuster to the spring at fault as covered in (4), except that in this case do not slide the adjuster to the base of the spring. Adjustment should be made at a point at least 1/4 inch forward from the insulators but not over a pretensioned bend.

Nonpretensioned Springs

- (6) To adjust a nonpretensioned spring for tension, place the spring adjuster on the spring just back of the operating stud and slide it back to the base of the spring as indicated in Fig. 26. Adjust the spring to the right or to the left as required, exercising care not to disturb adjacent springs. Do not adjust the spring any more than is necessary since repeated adjustment may injure the spring. Take care when adjusting the springs to adjust them in line with their movement

and to avoid tilting. Tilted springs cause unequal contact separation of the two pairs of contacts and may result in the failure of one of the contacts on the bifurcated spring to close.

(7) If the spring is excessively bowed or bent or if there is not the proper clearance between springs, straighten the spring before adjusting to meet the spring tension requirement. To straighten the spring, apply the proper spring adjuster to the spring just back of the bow or bend and, while exerting pressure to the right or left as required, draw the spring adjuster forward the length of the bow. Repeat this operation as required until the spring is approximately straight. Take care when making this adjustment to avoid tilting the springs.

(8) If the desired tension cannot be obtained by adjusting as outlined in (6) without bowing the spring beyond its permissible limit or reducing the clearance between the springs below the specified minimum, apply the proper spring adjuster to the spring just back of the operating stud and slide it back to the base of the spring as indicated in Fig. 26. Then draw the adjuster forward the length of the spring so the spring is formed into a slight gradual bow with the concave surface facing the armature as indicated in Fig. 27. Then move the adjuster to the base of the spring, and adjust as covered in (6). The magnitude of the bow to be formed in the spring must be learned by experience and should be such that, when the final tension adjustment is made at the base, the spring will be approximately straight.

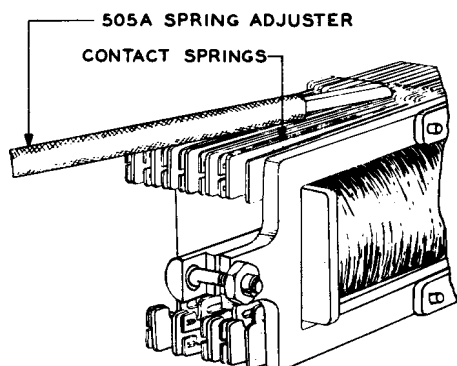

Fig. 26—Method of Adjusting Spring Tension

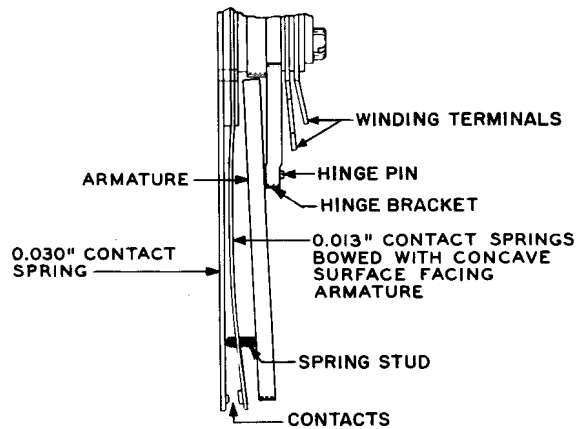

Fig. 27—Position of Bowed Spring Before Final Tension Adjustment

(9) If the studs touch the spring through which they pass, it is probably due to a twist in the spring to which the stud is attached as a result of adjustment. To correct this, apply the proper spring adjuster to the spring at fault and adjust it so there is the required clearance between the stud and the springs.

(b) **Kinked Springs:** Do not straighten kinked spring unless the kink interferes with the proper adjustment of the spring assembly. Removing kinks tends to weaken the spring and to shorten its life. Normally straight springs that have been adjusted should have no sharp bends due to adjustment, except that a kink near the base of thin (0.013 and 0.018 inch) springs is permissible when necessary to obtain required tension. A gradual bow, however, is permissible.

(c) **Adjustment for Pressure of Armature Against the Adjusting Nut:** If the armature

is not held against the backstop with the specified pressure or if the relay is equipped with a pin hinged armature and the portion of this pressure in one spring combination is more than 2-1/2 times that of the other spring combination, alter the tension of the D and A springs which are tensioned against the armature as necessary using the 505A or 506A spring adjusters as in (4) or (6) depending on whether the relay is equipped with pretensioned springs or nonpretensioned springs, respectively. In making this adjustment, first increase the tension of the D or A spring farthest from the armature whose tension is transmitted to the armature through one or

more studs. If the requirement cannot be met by this means alone, adjust the other springs which hold the armature against the backstop as required. For example, in the case of a relay equipped with a 170-146 spring combination, first adjust spring 3 of the top combination or spring 2 of the bottom combination or both as required. If sufficient tension is not obtained by adjusting these springs, increase the tensions of 5, 7, 9, and 11 of the top combination and springs 5, 7, and 9 of the bottom combination. It is not necessary to distribute the tensions of the A and D springs equally, but the combined pressure of the studs against the top and bottom legs of the armature should meet the specified requirement.

(d) **Position of X' Buffer Springs Designated**

F: When it is necessary to adjust the tension of a buffer spring having F tension, check it for position in accordance with requirement 2.13 and adjust it as required in accordance with 3.18 through 3.21(a).

3.18 Stud Gap: (Reqt 2.18)

3.19 Contact Make: (Reqt 2.19)

3.20 Contact Separation: (Reqt 2.20)

3.21 Contact Sequence: (Reqt 2.21)

(a) Failure to meet these requirements is due to contact and spring stud wear. Three means are available to compensate for this wear.

(1) Adjustment of individual movable springs and spoolhead spring tangs. This should be done where only minor adjustments are required.

(2) Use of a spring stud cap (0.006, 0.009, or 0.012 inch thick) on spring studs adjacent to armature legs as shown in Fig. 29. These caps should be used in preference to making other than minor spring or spring tang adjustments.

(3) Use of an armature plate (0.030 inch thick) on armature legs as shown in Fig. 30. These plates should be used when considerable bending of the springs and spring tangs has been done during prior adjustment.

(b) **Minor Adjustment of Springs and Spring Tangs**

(1) **Stud Gap and Contact Make:** If only minor adjustment is needed to meet these requirements, adjust the spring tang to the right or left as required using the 507A spring adjuster, while holding the spring with another 507A spring adjuster as shown in Fig. 28. It is satisfactory if in making this adjustment the spring tang does not rest flat against the spoolhead. Make sure, however, that requirement 2.06 covering spring tang position is met. If failure to meet the contact make requirement is due to misalignment of the prongs of the bifurcated spring, adjust the individual prongs with the 363 spring adjuster so both prongs are approximately in the same vertical plane. Adjust so there are stud gaps at the points indicated on spring combination Fig. 101 through 350. The use of the 510C test lamp equipped with the 561A straight tip or the 562B curved tip to illuminate the stud gap will facilitate making this adjustment. Where it is necessary to check the stud gaps by moving the armature towards the core manually, operate the relay electrically two or three times after checking the stud gaps to restore the armature to its position against the front ends of the hinge bracket (Fig. 27), thus preventing false contact operation.

(2) **Contact Separation:** If only minor adjustment is needed to correct the control separation, adjust the movable springs with the 505A spring adjuster or adjust the spring tang on the spoolhead springs as covered in (1). In adjusting the front contact separation on break-make units of a spring combination, adjust the springs tangs on the spoolhead springs so the contact separation is sufficient to insure that the contact sequence requirement will be met under operating conditions. If the requirement is not met due to the misalignment of the prongs of the bifurcated spring, adjust the individual prongs with the 363 spring adjuster so that the contact separation at both prongs is approximately the same and so that the two prongs of the bifurcated spring are approximately in the same vertical plane.

(3) **Contact Sequence:** To adjust for contact sequence, change the spring tension, contact

make, stud gap, and contact separation adjustments as required.

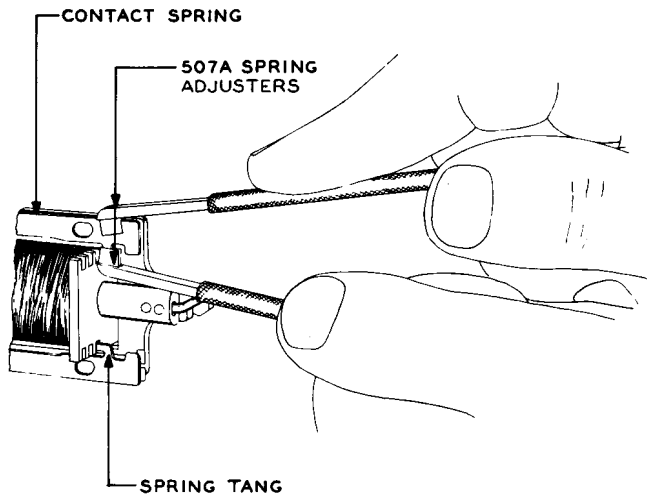

Fig. 28—Method of Adjusting Spring Tang

(c) **Mounting Spring Stud Caps**

(1) Before mounting spring stud caps, place a KS-14666 cloth over the apparatus mounted below the relay on which work is being done. This will prevent caps, which may be dropped, from lodging on springs or other parts of the apparatus.

(2) Select the cap which when mounted will necessitate only minor spring and spring tang adjustment. A comparison of stud cap thickness to the reduction in contact separation provided by the caps is shown in Table A.

TABLE A — SPRING STUD CAPS

SPRING STUD CAP	COLOR OF CAP	NOMINAL VALUE OF CAP THICKNESS (inches)	APPROXIMATE CHANGE IN CONTACT SEPARATION (inches)
P-10F548	WHITE	0.006	0.008
P-10F137	RED	0.009	0.012
P-10F138	GREEN	0.012	0.016

(3) Place the stud cap open side up in the recess in the end of the KS-21034 applicator tool. Position the tool between the armature and the adjacent spring (Fig. 29) and push the cap over the stud. Remove the applicator tool.

(4) After mounting a spring stud cap, check the relay to all requirements covering the springs and also to the electrical requirements.

(d) **Mounting Armature Plates**

(1) To mount a P-11A706 armature plate on the lower leg of the armature or the P-11A707 armature plate on the upper leg, proceed as follows. Insert the KS-6320 orange stick between the armature leg and the adjacent spring until the tip of the orange stick rests against the spring stud. Move the spring away from the armature to provide stud clearance for mounting the armature plate. Holding the armature plate with the disc toward the relay springs, place the rear clip of the plate over the leg of the armature. Slide the plate toward the rear of the relay until the front clip fits snugly against the front edge of the armature leg. Withdraw the orange stick, and check that the end of the spring stud rests against the armature plate within the circumference of the disc on the plate. Also check that the positioning tab and the rear clip of the plate rest against the inner edge of the armature leg as shown in Fig. 30. If necessary, properly position the plate on the armature leg with the orange stick.

(2) After mounting the armature plate, check the relay to all requirements covering the springs and also the electrical requirements.

3.22 **Electrical Requirements:** (Req't 2.22)

(a) Operate the relay on the specified soak current, or operate current if no soak is specified, and check for hold and release. If the relay fails to release in approximately 1 1/2 seconds and has no buffer springs, increase the tension of the weaker moving springs. If the relay has buffer springs, add tension to the weaker buffer spring, making repeated checks for operate, hold, and release and observing 3.10(a) until the relay just fails to hold. Then

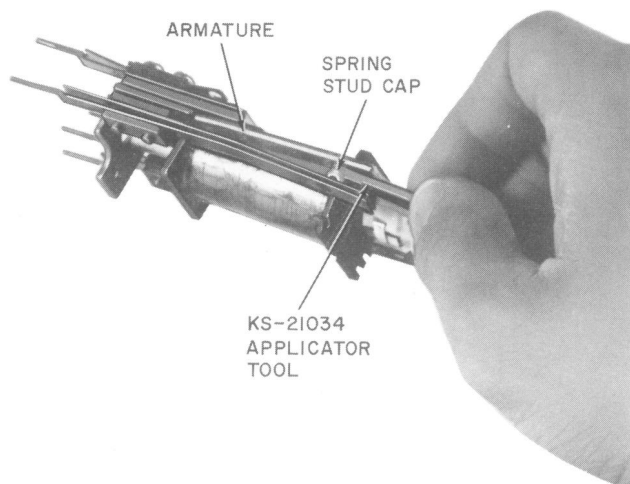

Fig. 29—Method of Mounting Spring Stud Cap

reduce this tension just sufficiently to cause the relay to hold on its hold current. If the pressure required for release causes failure to hold or operate, the relay probably has high residual and a D-167911 magnetic separator may be necessary to permit it to be adjusted.

Caution: *If too much reliance is placed on the buffer springs to meet the release requirement, a slowing up of the armature movement or a complete stop of the armature may result when it picks up the buffer spring load. If this occurs, adjust the buffer spring or springs to be picked up later in the armature stroke within the limits specified in requirement 2.13 [(a)(1) and (2)] and, if necessary, increase the tension of the moving springs of both spring assemblies.*

(b) When adjusting relays to meet the release requirements, adjust the relays to release on as high a current as possible consistent with meeting the operate and hold requirements. Where the relay is equipped with buffer springs, it is desirable to obtain this higher release by using the buffer springs in conjunction with the moving springs, rather than attempting to overtension the moving springs. When buffer springs are not provided, adjust the tension of the moving springs as high as possible consistent with meeting the operate and hold requirements.

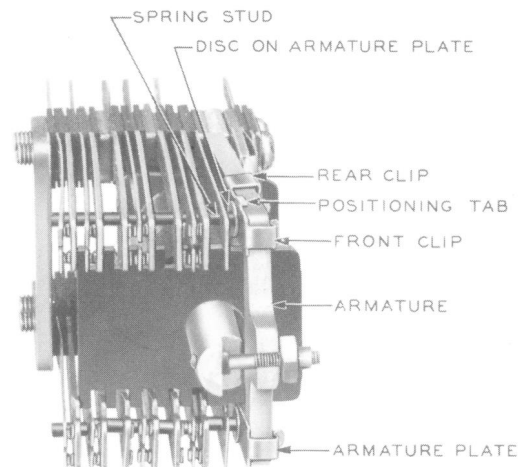

Fig. 30—Armature Plates Mounted on Armature Legs of Y-Type Relays

(c) If a relay fails to operate on its specified operate current, note whether it fails to start or whether it operates part way and then stops. If the relay fails to start, its initial load is too great and tension must be removed from the moving springs which are tensioned directly or indirectly against the armature in the normal position. Locate the moving springs having high tensions, and remove the required amount of tension from them. If the armature operates part way and then stops and the relay has no buffer springs, the same procedure applies to all of the moving springs.

(d) If the relay is equipped with one or two buffer springs and the armature in operating stops or hesitates perceptibly when the buffer spring load is picked up, check for correct buffer spring pickup as covered in requirement 2.13 and correct if necessary. Repeat the operate test, and if the armature still stops or hesitates when the buffer spring load is picked up, remove tension from the buffer spring having the higher tension or from both springs as required.

(e) If the relay must meet a nonoperate requirement, check it for this adjustment immediately after adjusting it to operate and, if it fails to meet it, increase tension in the weaker moving springs enough to meet the nonoperate without causing failure to operate.