

TIME-DELAY RELAY, KS-15513
EAGLE SIGNAL CORPORATION
REQUIREMENTS AND ADJUSTING PROCEDURES

1. GENERAL

1.01 This section covers time-delay relay, KS-15513, manufactured by the Eagle Signal Corporation. The relays are primarily used with the 900-type power plant control circuits.

1.02 Reference shall be made to Section 020-010-711 covering general requirements and definitions for additional information necessary for the proper application of the requirements listed herein.

1.03 *Asterisk:* Requirements are marked with an (*) when to check for them would necessitate dismantling or dismounting of apparatus, or would affect the adjustment involved or other adjustments. No check need be made for these requirements unless the apparatus or part is made accessible for other reasons, or its performance indicates that such a check is advisable.

1.04 The KS-15513 time-delay relay consists of a relay, a synchronous motor, a gear train, and adjustable tripping cams which are arranged to control the individual operation of the contacts. The camshaft is driven by the motor through a clutch operated by the relay. A time delay of 5 minutes or less in the operation of the relay contacts is obtained by adjusting the cam settings. At the end of the delay interval, the relay contacts are tripped by the cams. When the relay coil is de-energized, the entire apparatus resets itself.

1.05 For the purpose of this section, whether contacts of a relay are *normally open* (NO) or *normally closed* (NC) depends on the position of these contacts when the operating coil is de-energized and not on the position the contact may normally be in for a particular application.

1.06 Because of the relatively high voltage on the terminals, all requirements except the electrical requirements should be checked, and all adjusting procedures performed with the associated circuit removed from service. When the relays are in main control cabinets, take them out of service as covered in the section covering the operating methods. When checking the electrical requirements, see that the contacts are disconnected from the associated circuit.

Caution: Use care when working in close quarters with live parts.

1.07 To check or adjust for any requirement remove the thumb nuts and remove the cover.

1.08 *One drop of oil* for the purpose of this section, is the amount of KS-6232 oil discharged from the nozzle of the No. 486A oilcan when the sides of the can are depressed once and held depressed until the drop is released from the nozzle.

2. REQUIREMENTS

2.01 *Mounting of Relay and Cover*

(a) The relay shall be fastened securely to its mounting.

Gauge by feel.

(b) Thumb nuts shall hold the relay cover securely in place.

Gauge by feel.

2.02 *Cleaning*

(a) Contacts shall be cleaned when necessary as covered in Section 069-306-801.

(b) Other parts shall be cleaned when necessary in accordance with approved procedures.

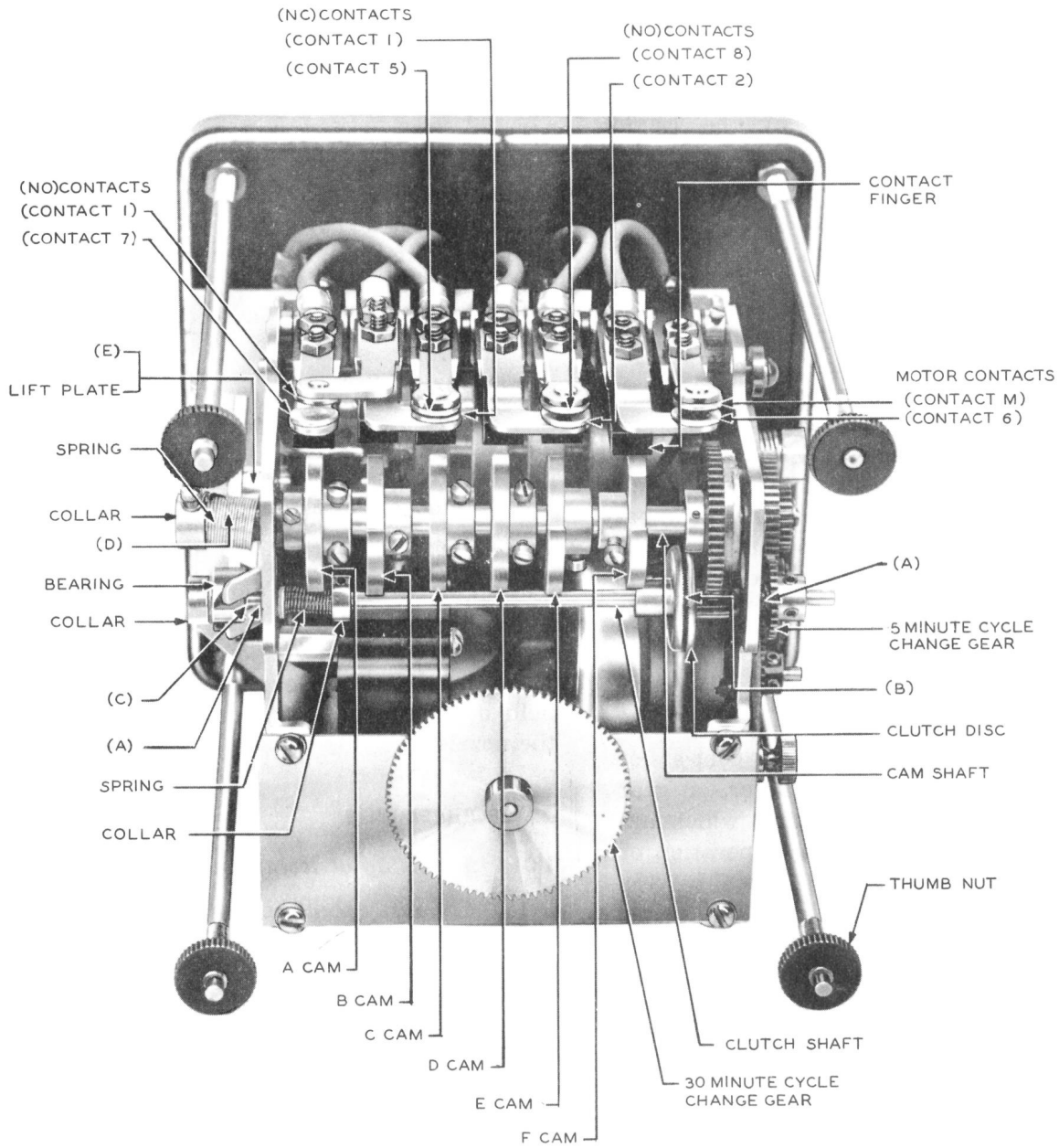

Fig. 1 - KS-15513 Time-delay Relay

2.03 Lubrication

(a) The following parts shall be adequately lubricated with KS-6232 oil. When lubrication is necessary one drop of oil shall be applied to each of the following points.

- (1) Fig. 2(A) — Gear shaft at bearings (three points).
- (2) Fig. 1(A) — Clutch shaft at bearings (two points).
- (3) Fig. 1(B) — Clutch shaft at right-hand clutch disc.
- (4) Fig. 1(C) — Clutch shaft at clutch bearing.
- (5) Fig. 2(B) — Camshaft at right bearing.

- (6) Fig. 1(D) — Camshaft at left bearing.
- (7) Fig. 1(E) — Lift plate at left bearing.
- (8) Fig. 2(C) — Lift plate at right bearing.

(b) **Recommended Lubrication Intervals:** It is recommended that all parts be lubricated at yearly intervals. The interval may be extended if periodic inspections have indicated that local conditions are such as to insure that requirement (a) is met during the extended interval.

2.04 Record of Lubrication: During the period of installation, a record shall be kept by date of the lubrication and this record shall be turned over to the telephone company with the equipment. If no lubrication has been done, the record shall so state.

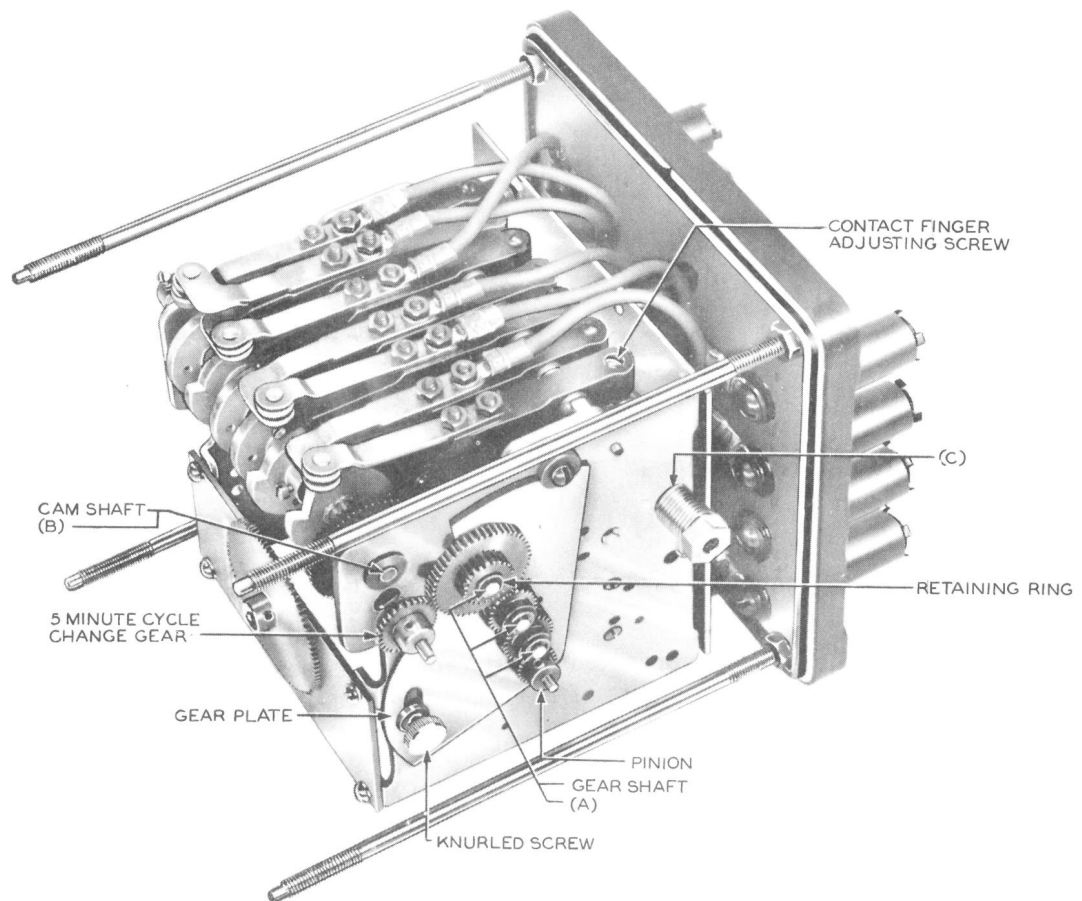

Fig. 2 — KS-15513 Time-delay Relay

2.05 Contact Separation: Fig. 1 — The separation between any pair of normally open (NO) contacts (contacts 1 and 7 and contacts 2 and 8) or between any pair of normally closed (NC) contacts (contacts 1 and 5) or motor contacts (contacts 6 and M) that are opened when the associated cams trip the associated contact fingers shall be

1/16 inch

Gauge by eye.

To check NO contacts observe the separation with the relay in the reset position. To check the NC contacts and the motor contacts operate and hold operated the armature arm (Fig. 3). Make sure that the contact fingers rest on their associated cams. Disengage the clutch by moving the clutch lever to the left. Then while holding the lever in this position rotate the cams until the cams associated with the contacts are rotated enough to cause the contacts to completely open.

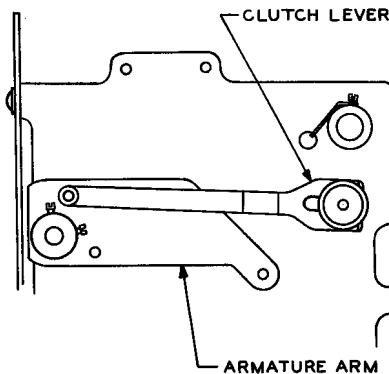

Fig. 3 — Relation Between Armature Arm and Clutch Lever

2.06 Separation Between Cam and Contact Finger

(a) Fig. 4(A) — With the relay unoperated the separation between the high points of all cams and their associated contact fingers shall be

1/32 inch

Gauge by eye.

To check the requirement rotate the camshaft until the point on the periphery of the cam just before the cam drop-off is below the end of the contact finger.

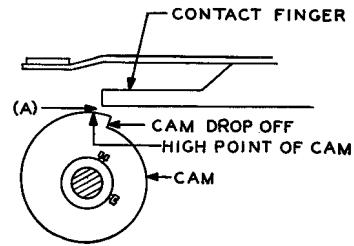

Fig. 4 — Separation Between High Point of Cam and Contact Finger

(b) Fig. 5(A) — With the relay operated and the NO contacts closed the separation between B and E cams and their associated contact fingers shall be

1/64 inch

To check operate and hold operated the armature arm. Disengage the clutch by pushing the clutch lever to the left. Rotate the camshaft until the cams trip their associated contact fingers.

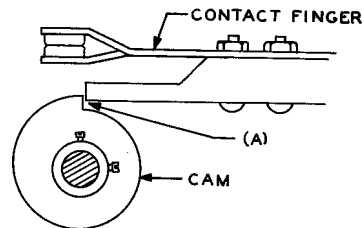

Fig. 5 — Separation Between B or E Cam and Contact Finger

2.07 Separation Between Finger and Lift Plate: Fig. 6(A) — With the armature

arm operated there shall be a clearance between the fingers associated with contacts 1 and 8 and the lift plate of

1/64 inch

Gauge by eye.

To check operate and hold operated the armature arm. Disengage the clutch by moving the clutch lever to the left. Rotate the camshaft until contacts 1 and 8 are tripped. Check the requirement by applying a KS-6320 orange stick to the associated fingers and noting that there is movement.

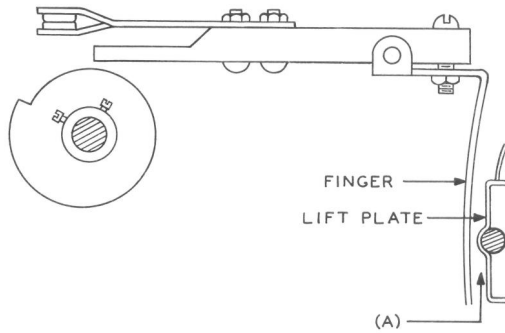

Fig. 6 - Separation Between Finger and Lift Plate

2.08 Cycle Change Gear Position: With the clutch discs fully meshed the outside surface of the cycle change gear shall be in approximate alignment with the outside surface of the associated gear on the gear plate.

Gauge by eye.

To check this requirement operate the armature arm and if necessary push the clutch shaft as required until the teeth of the clutch discs are fully meshed.

2.09 Engagement of Gears: The teeth of the cycle change gear shall not bind on the associated gear.

Gauge by eye and feel.

To check this requirement proceed as follows. Loosen the pinion setscrews using the R-2959 set-screw wrench. Rotate the cycle change gear one revolution clockwise and counterclockwise and note by feel and observation whether there is play between the gears or whether they tend to bind. Tighten the pinion setscrews securely.

2.10 Operation of Clutch

(a) When the armature is held operated the teeth of the clutch discs shall be fully meshed.

Gauge by eye.

To check this requirement operate the armature arm and note the engagement of the clutch.

(b) With the armature released there shall be a separation between the clutch discs of 1/32 inch

Gauge by eye.

2.11 Operation of Camshaft: The camshaft shall reset promptly without excessive force, when the armature is released.

Gauge by eye.

To check this requirement operate and hold operated the armature arm. Rotate the camshaft to the limit of its travel. Release the relay observing the action of the camshaft.

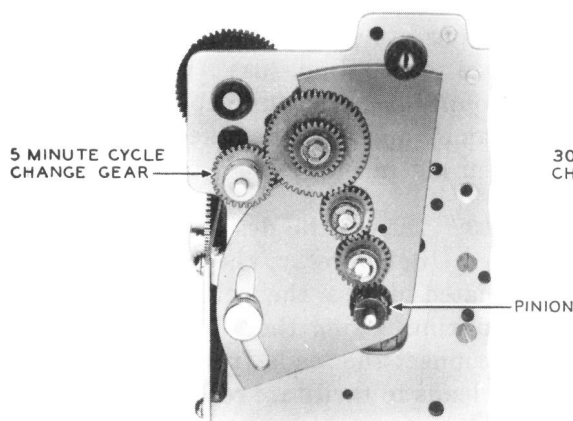

Fig. 7A - 5-minute Timer

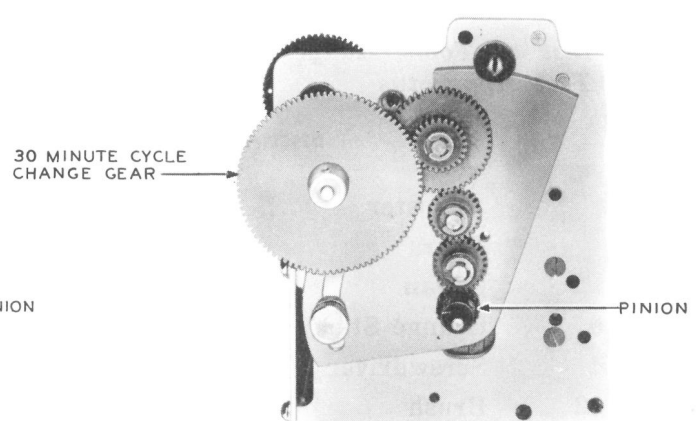

Fig. 7B - 30-minute Timer

Fig. 7 - Position of Cycle Change Gears

SECTION 040-665-701

2.12 Motor Operation: The motor shall operate to drive the gear train and trip cams.

Gauge by eye.

2.13 Timing Requirements: The time delay shall be as specified in the circuit requirement table or other job information.

Use any available clock or watch.

2.14 Electrical Requirements

(a) The relay shall meet the electrical requirements specified in the circuit requirement table or other job information.

(b) When electrical requirements are not so specified, operation of the relay shall be checked at the minimum voltage given on the nameplate.

***2.15 Temperature:** The temperature shall not exceed the following values.

	MAX
Motor	90C (194F)
Coil	105C (221F)
Contacts	115C (239F)

Use the Kimble thermometer.

If the temperature is thought to be excessive check as follows. Hold the bulb of the thermometer against the hottest spot in question, covering that part of the bulb not in contact with the apparatus by a piece of felt, or the equivalent.

3. ADJUSTING PROCEDURES

3.001 List of Tools, Gauges, Materials, and Test Apparatus

CODE OR SPEC NO.	DESCRIPTION
TOOLS	
326B	Adjuster
485A	Pliers
486A	Oilcan
KS-6320	Orange Stick
KS-6854	Screwdriver
KS-14162	Brush
R-2959	1/16-inch Allen Socket Screw Wrench
—	3-inch Cabinet Screwdriver
—	4-inch Regular Screwdriver
—	5-inch Regular Screwdriver

CODE OR SPEC NO.	DESCRIPTION
GAUGES	
—	Clock or Watch
R-1032 Detail 1 or 2	Thermometer
—	Voltmeter, ac, Weston Model 528, Range 0-150-300
MATERIALS	
KS-2423	Cloth
KS-6232	Oil
KS-7860	Petroleum Spirits
—	Felt Pad
—	No. 14 Wire
TEST APPARATUS	
KS-6780 (As required)	Connecting Clip
—	Autotransformer, Continuously Tapped (Variac, 2 amp, 230-volt input, Type V-5HMT)

3.002 General: Care should be exercised when using KS-7860 petroleum spirits in power rooms where there are dc machines, since commutation may be adversely affected by the softening of the commutator film by the fumes. To avoid the need for burnishing the commutators of the dc machines after doing any cleaning operations called for in this section, provide adequate ventilation, use the absolute minimum amount of petroleum spirits required for the cleaning operation, and keep the container closed when not in use.

3.003 Due to the design of the KS-15513 time-delay relay, the lift plate cannot be lubricated unless the relay is removed from its mounting. Using the 4-inch regular screwdriver disconnect the leads from the terminals tagging the leads to facilitate reconnecting them. Remove the relay mounting screws using the 5-inch regular screwdriver. Remove the relay from its mounting and remove the cover. After the lift plate has been properly lubricated, mount the relay securely in place and connect the leads to the proper terminals.

3.01 Mounting of Relay and Cover (Rq 2.01)

- (1) Tighten loose relay mounting screws with the 5-inch regular screwdriver.
- (2) Tighten loose thumb nuts using fingers.

3.02 Cleaning (Rq 2.02)

- (1) **Contacts:** Clean contacts as covered in Section 069-306-801. If contacts are badly pitted refer the matter to the supervisor.
- (2) **Bearings:** If, upon inspection, there is found to be an accumulation of gummy oil or foreign matter on the bearings, apply KS-7860 petroleum spirits to the bearings using the KS-14162 brush. Manually operate the shafts a few times and then wipe off excess petroleum spirits and foreign matter with a piece of KS-2423 cloth. Repeat this operation until all dirt has been removed and then re-lubricate the parts as covered in 3.03.
- (3) **Cover:** Clean the inside of the cover by wiping it with a clean KS-2423 cloth.

3.03 Lubrication (Rq 2.03)

- (1) **Gear Shaft Bearing:** Using the No. 486A oilcan apply one drop of KS-6232 oil to the shaft of each gear at the opening of the retaining ring.
- (2) **Clutch Shaft Bearings:** To lubricate the shaft at the right bearing first operate and hold operated the armature arm. Using the No. 486A oilcan apply the KS-6232 oil at the right end of the bearing. Release the armature arm. To lubricate the shaft at the left bearing and at the right-hand clutch disc first push the shaft to the left to the limit of its travel and hold it in this position. Using the No. 486A oilcan apply the KS-6232 oil to the shaft at the left end of the bearing and to the shaft at the inner surface of the right-hand clutch disc. Release the clutch shaft. To lubricate the shaft at the clutch bearing, using the No. 486A oilcan apply the KS-6232 oil at the right side of the bearing.
- (3) **Camshaft Bearings:** To lubricate the camshaft at the right bearing using the No. 486A oilcan apply the KS-6232 oil to the right end of the shaft at the bearing. To lubricate the shaft at the left bearing, using the KS-6320 orange stick separate the turns of the clutch shaft spring near the middle of the spring and using the No. 486A oilcan apply the KS-6232 oil.

- (4) **Lift Plate Bearings:** Using the No. 486A oilcan apply the KS-6232 oil to the lift plate shaft at the left side of the left bearing and to the shaft at the left side of the right bearing.

3.04 Record of Lubrication (Rq 2.04)
(No Procedure)**3.05 Contact Separation (Rq 2.05)****3.06 Separation Between Cam and Contact Finger (Rq 2.06)****3.07 Separation Between Finger and Lift Plate (Rq 2.07)**

- (1) To adjust for the separation of contacts with the relay operated proceed as follows. Manually operate and hold operated the armature arm. Observe that the contact fingers rest on their associated cams. Using the No. 326B adjuster adjust the contact springs (contacts 1 and 8) of the NO contacts until the contact separation is satisfactory. Disengage the clutch by moving the clutch lever to the left while holding the armature arm operated. Rotate the camshaft to a point where the NC contacts open. Using the No. 326B adjuster adjust the contact springs (contacts 5 and M) until the contact separation is satisfactory. Release the armature arm. Check requirement 2.06(a).
- (2) To adjust for the separation between the high point of A, C, D, and F cams and their associated contact fingers proceed as follows. Rotate the camshaft until the point on the periphery of the cam just before the cam drop-off is below the end of the contact finger. Using the 3-inch cabinet screwdriver turn the contact finger adjusting screw (contacts 7, 5, 2, and 6) as required until the contact separation is satisfactory. Check requirement 2.06(b).
- (3) To adjust for the separation of the NO contacts and the motor contacts with the relay unoperated proceed as follows. Using the 3-inch cabinet screwdriver turn the contact finger adjusting screw (contacts 1, 8, and M) as required. Check requirements 2.06 and 2.07.

3.08 Cycle Change Gear Position (Rq 2.08)

- (1) To adjust the position of the cycle change gear on the clutch shaft proceed as follows. Using the R-2959 wrench loosen the setscrews and position the gear on the shaft as required. Tighten the setscrews.

3.09 Engagement of Gears (Rq 2.09)

(1) To adjust for the engagement of the cycle change gear and the associated gear on the gear plate loosen the knurled screw which holds the gear plate in place. Position the gear plate as required so that the teeth of the gears are properly meshed. Tighten the knurled screw securely.

3.10 Operation of Clutch (Rq 2.10)

(1) If the teeth of the clutch discs are not fully meshed when the armature arm is operated, correct by adjusting the tension of the clutch shaft spring. To do this loosen the setscrew in the collar using the R-2959 wrench. Move the clutch lever to the left. Position the collar between A and B cams as required. Rotate the camshaft to the limit of its travel making sure that the collar does not touch A and B cams. Tighten the setscrew securely.

(2) To adjust for the separation between the clutch discs, proceed as follows. Using the R-2959 wrench loosen the setscrew in the collar at the left end of the clutch shaft and move it to the right on the shaft as required. Tighten the setscrew securely.

3.11 Operation of Camshaft (Rq 2.11)

(1) Observe the action of the trip cams when the relay is de-energized. If the camshaft binds this may be due to dirt in the bearings. Clean the bearings as covered in 3.02. If the camshaft still does not return to its reset position correct by adjusting the tension of the camshaft. To do this, using the KS-6854 screwdriver, loosen the screw which holds the spring in place on the left end of the camshaft. Rotate the collar five eighth turn or as required. Tighten the screw securely.

3.12 Motor Operation (Rq 2.12)

(1) If the motor fails, refer the matter to the supervisor.

3.13 Timing Requirements (Rq 2.13)

(1) If the relay fails to meet the specified time-delay requirements proceed as follows.

(2) If the time-delay requirement specifies that the NO contacts (contacts 1 and 7 and contacts 2 and 8) shall close at the end of

a 5-minute time-delay period, proceed as follows. Using the KS-6854 screwdriver loosen the screws on B or E cam. Mark one of the teeth of the pinion. Mark a point on the surface of the gear plate opposite the mark on the tooth of the pinion and designate it X position. Loosen the pinion setscrews with the R-2959 wrench. Rotate the pinion clockwise several revolutions to eliminate any accumulated backlash. Stop when the marked tooth is at the X position. Close the clutch by operating the armature arm. Turn the pinion clockwise five complete revolutions. Rotate B and E cams until the cam drop-off is positioned against the end of the contact finger. See Fig. 8. Drop-off of F cam should be slightly behind drop-off of B or E cams. Adjust for this condition as required (approximately one tooth of pinion). Tighten cam screws securely. Repeat for next cam setting. Release the relay. Tighten pinion setscrews securely. Recheck requirements 2.05, 2.06, and 2.07.

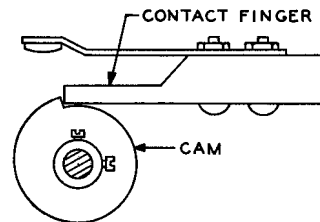

Fig. 8 — Relation of B or E Cam and Contact Finger

(3) If the time-delay requirement specifies that the NO contacts (contacts 1 and 7 and contacts 2 and 8) shall close before the end of the 5-minute time-delay period, proceed as follows. Using the KS-6854 screwdriver loosen the screws on B or E cam. Mark one of the teeth of the pinion. Mark a point on the surface of the gear plate opposite the mark on the tooth of the pinion and designate it X position. Loosen the pinion setscrews with the R-2959 wrench. Rotate the pinion clockwise several revolutions to eliminate any accumulated backlash. Stop when the marked tooth is at the X position. Close the clutch by operating the armature arm. Turn the pinion clockwise the number of revolutions and/or teeth

specified in Table A corresponding to the required timing operation. Rotate the cam until the cam drop-off is positioned against the end of the contact finger. See Fig. 8. Tighten cam screws securely. Repeat for next cam setting.

TABLE A

Cam	Contacts	Set to Close At	Turn Pinion From X Position Clockwise (Only for relay having the 5-minute cycle change gear in the gear train)
B	1-7	15 to 25 seconds	7 teeth
E	2-8	4 min and 10 to 15 sec	4 revolutions + 4 teeth
B	1-7	4 min and 30 to 35 sec	4 revolutions + 10 teeth
E	2-8	4 min and 45 to 55 sec	4 revolutions + 16 teeth

Release the relay. Tighten pinion setscrews securely. Recheck requirements 2.05, 2.06 and 2.07.

- (4) Where the time delay is specified as 30 minutes, there is no adjusting procedure.

3.14 *Electrical Requirements* (Rq 2.14)

- (1) A check of the operation of the relay is made by connecting the Weston Model 528 voltmeter across the coil terminals. If there is no indication on the voltmeter, a study of the

associated circuit is necessary to determine whether the absence of voltage indicates a circuit fault or is a condition to be overcome by blocking a relay or otherwise changing circuit conditions. Failure to operate with rated voltage at the coil terminals may sometimes be corrected by readjustment, but in some cases it may be due to an open coil. To check for an open coil, connect the voltmeter in series with the operating voltage and the coil. If no indication appears on the voltmeter, the coil is open and the relay should be replaced.

- (2) Connect the ac supply to the input of a continuously tapped autotransformer protected by a 2-1/2- or 3-ampere fuse. Connect the relay coil and the Weston Model 528 voltmeter across the output of the autotransformer and adjust to specified values.

- (3) If the relay fails to operate at the specified minimum voltage with requirements 2.02, 2.03, 2.09, and 2.12 met, refer the matter to the supervisor as the relay may have to be replaced.

3.15 *Temperature* (Rq 2.15)

- (1) If the temperature exceeds the specified limit, see that requirement 2.04 is met. If this requirement is met and the temperature is above the specified limit and the maximum voltage given on the nameplate is not exceeded, refer the matter to the supervisor as the affected part or the entire relay may have to be replaced.