

KS-15623 THERMAL OVERLOAD RELAY REQUIREMENTS AND ADJUSTING PROCEDURES

1. GENERAL

1.01 This section covers the apparatus requirements and adjusting procedures for KS-15623 thermal-type time-delay relays.

1.02 The KS-15623 thermal overload relays are intended for use in the 900-type automatic engine-alternator plants and associated control circuits per J86620 and J86621.

1.03 Reference shall be made to Section 020-010-711 covering general requirements and definitions for additional information necessary for the proper application of the requirements listed herein.

1.04 Requirements and associated procedures marked with a number sign (#) need not be checked by the installer unless it is thought that the requirement is not being met or performance indicates that such a check is advisable.

1.05 Requirements and associated procedures marked with an asterisk (*) need not be checked during maintenance unless the apparatus or part is made accessible for other reasons, or performance indicates that such a check is advisable.

1.06 In this section the term resistor is used for all apparatus coded as either a resistor or a resistance.

1.07 Description: The KS-15623 relay unit consists of a heater element, a bimetallic strip with a set of contacts, and a relay. After the heater element has been energized for a prescribed time interval, the bimetallic strip snaps away from the holding magnet and makes contact with the stationary thermal relay contact. When these two contacts close, the relay coil is energized thus actuating the relay armature. The relays are arranged for either automatic or manual reset. On relays arranged for manual reset, a latch with a reset button is provided. The time required for the bimetallic strip contacts to close varies inversely with the heater current and is adjustable over a limited range. The relay contacts are of the double-pole, single throw, normally open type.

1.08 Definitions: For the purpose of this section the terms explained below will be used in describing the requirements and adjusting procedures. The relay unit refers to the composite structure consisting of an insulated mounting, an electromagnet, a heater element, a bimetallic strip with its associated contacts, termina

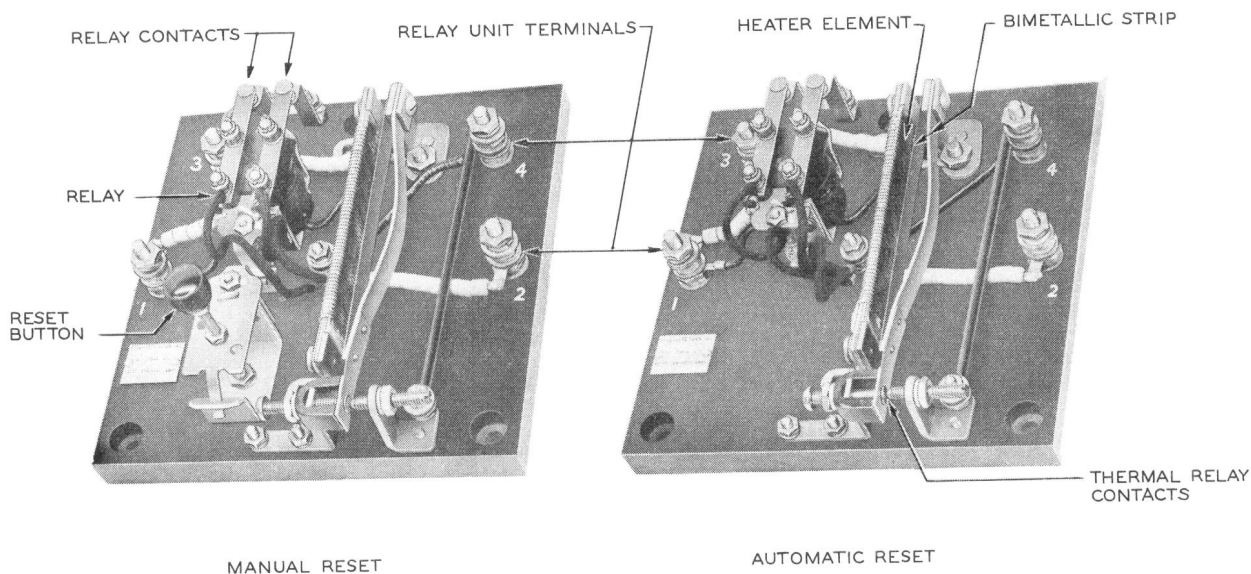

FIG. 1 - TYPICAL KS-15623 RELAYS

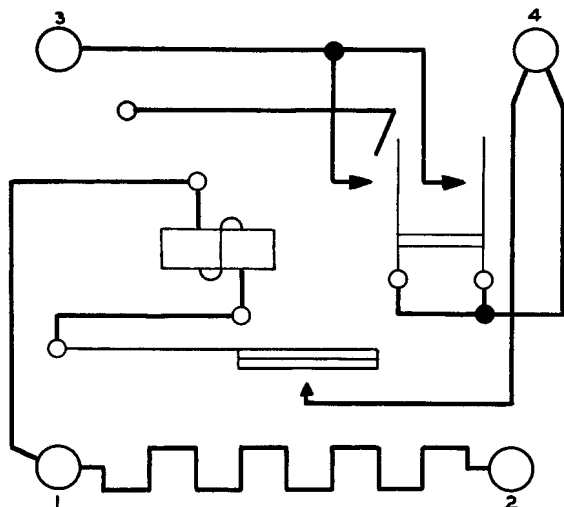

Fig. 2 - Schematic Diagram
KS-15623 Relay

posts, and, when included, the reset mechanism. The relay refers to the electromagnet with its attached contacts. The thermal relay refers to the combination of the heater element, and the bimetallic strip with its associated contacts.

2. REQUIREMENTS

- *2.01 Relay Unit Mounting: The relay unit parts shall be fastened securely to the insulated base. Gauge by feel.
- *#2.02 Contact Surfaces shall be clean and free from build-ups which might interfere with reliable contact. Gauge by eye.
- *#2.03 Contact Pressure of the relay, with the contacts closed, shall be Min. - 20 grams. Use gauge.
- *#2.04 Contact Clearance
 - (a) The clearance of the relay contacts shall be adjustable and shall be no less than 0.055 inch. Use gauge.
 - (b) The clearance of the thermal relay contacts shall be adjustable and shall be set at such a distance that the circuit requirements of the associated circuit or plant are satisfied. See 2.05.
- *#2.05 Timing: The operating time of the KS-15623 thermal overload relays shall be adjustable over a limited range by means of a screw arrangement which changes the distance between the magnet and the bimetallic strip. The timing shall be as shown below when the room temperature is at 70F:

List No.	Timing (Seconds)	Applied Volts (D-C)
1	35 ±5	24
2	120 ±20	32

Use watch and voltmeter.

*#2.06 Relay Requirements: The coil shall actuate the relay positively, without hesitating, when the voltage shown below is applied to the relay winding terminals.

List No.	Voltage (D-C)
1	20
2	28

Use voltmeter.

*#2.07 Temperature: The temperature of the relay parts shall be as follows:

Part	Max. Temperature
Coils	105C (221F)
Contacts	115C (239F)

Use thermometer.

3. ADJUSTING PROCEDURES

3.001 List of Tools, Gauges, Materials, and Test Apparatus (Equivalents may be substituted)

- Burnisher, contact, No. 265C tool
- Clip, No. 365 tool (two required per cord) (or KS-6278)
- Cloth, abrasive, 150 grade (see Section 065-370-101)
- Cloth, cleaning, twill jean, D-98063
- Cord, No. 1W13A or 1W13B
- Gauge, 70H
- Gauge, 126D
- Meter, KS-14510 volt-ohm-milliammeter
- Pliers, No. 485A Tool
- Resistors, W.L., Type 160F, 4 ohms, 6.32 amps, 160 watt
- Rheostat, W.L., Cat. 1107-6, 6.4 ohms, 3.95 amps, 100 watt
- Screwdriver, 3" cabinet
- Spirits, Petroleum
- Thermometer, R1032, Detail 1 or 2
- Wrench, 1/4" and 3/8", No. 417A Tool
- Wrench, 5/16" and 7/32", No. 418A Tool

3.002 General Procedure: Electrical requirements should be checked or work done on the contacts with the relay removed from service if possible. The use of 1W13A cords (3' 0") or 1W13B cords (6' 0"), with No. 365 tools (clips) or KS-6278 clips, at both ends is suggested. When checking the electrical requirements, set up a temporary testing circuit using the engine starting battery as a source of potential. Do not touch or otherwise

short circuit live parts or terminals which are at different potentials unless testing procedures require such action. Do not allow manual operation of the relay to disturb the normal operation of the associated circuit and plant. The test voltages of 20, 24, 28, and 32 volts must be obtained by placing the rheostat in series with the starting battery. For the KS-15623, List 1 relay carefully remove all leads from terminals 1, 2, 3, and 4, and identify by tagging. For the KS-15623, List 2 relay carefully remove the leads from terminals 1, 3, and 4 and identify by tagging. Make the necessary tests and replace all leads.

*#3.01 Relay Unit Mounting (Rq. 2.01)
Tighten loose mounting bolts with the screwdriver or the wrench.

*#3.02 Contact Surfaces (Rq. 2.02)

(a) The purpose of cleaning contacts is to remove any gummy or dirty substance that would interfere with reliable contact. It is not necessary or desirable to keep contacts polished or shining. Clean contacts by wiping with a cloth moistened with petroleum spirits, followed by a dry cloth. The contacts should be disconnected from the power supply during the cleaning operation whenever possible to do so without interfering with normal operation.

(b) There shall be as little smoothing of contacts as is consistent with satisfactory operation. Contacts should be smoothed while closed. To close normally open contacts, operate the relay electrically or manually. If the associated circuit has been disconnected from the contacts, insert a burnishing tool or strip of abrasive cloth between them and draw it back and forth until the build-ups have been reduced considerably or removed entirely. If the contacts are connected in a live circuit, use the abrasive cloth, only. Then clean the contacts as outlined in (a) above. Check contact pressure after cleaning or smoothing contacts.

*#3.03 Contact Pressure (Rq. 2.03)

(a) To measure the relay contact pressure, disconnect the contacts and energize the operating coil, or hold the armature securely against the pole face with a screwdriver, taking care not to press on any part of the contact spring which supports the moving contact. Place the tip of the gauge between the contacts and exert a pressure with the gauge away from the stationary contact. Read the gauge as the movable contact leaves the stationary contact.

(b) Contact pressure may be adjusted by relocating the stationary contacts or by shaping the movable contact spring or the stationary contact support. Check relay contact clearance after adjusting contact pressure.

*#3.04 Contact Clearance (Rq. 2.04)

(a) Minor changes in the contact clearance of the relay contacts can be made by forming the stationary contacts with the 485A tool. Major changes in contact clearance should be made by placing or removing spacing washers under the stationary contact arm of the relay. Check relay contact pressure after adjusting relay contact clearance.

(b) The thermal relay contact clearance can be adjusted by loosening the lock nut on the stationary contact support and turning the set screw. When proper clearance has been obtained, as indicated by satisfaction of requirements 2.04 (b) and 2.05, tighten the lock nut.

*#3.05 Timing (Rq. 2.05)

(a) To check the KS-15623, List 1 relay unit, apply the test potential to terminals 1 and 2 in accordance with the succeeding paragraphs. To check the KS-15623, List 2 relay unit, apply the test potential to terminal 1 of the relay unit and the far side of its associated rheostat which is in series with relay unit terminal 2. The rheostat is usually located near the relay and has the same designating letters, that is, relay SDT and rheostat SDT.

(b) The voltmeter must be connected at the same terminals that the test voltage is applied.

(c) Use the second hand of an ordinary watch or clock to time the interval between the closing of the test circuit and the click which occurs as the relay operates. Allow at least ten minutes between readings, for the heater and bimetallic strip to cool. If the relay fails to operate, it should be checked for an open circuit in the heater. Disconnect one or both heater leads and check for continuity with the KS-14510 meter.

(d) A slight adjustment of the operating time can be made by loosening the locknut on the magnet support and changing the clearance between the magnet poles and the bimetallic strip. Tighten after adjustment. If the

list 1 relay cannot be adjusted to meet the limits, it should be replaced. If the list 2 relay cannot be adjusted to meet the limits, the associated external rheostat may be readjusted. If this adjustment is insufficient the relay should be replaced.

***#3.06 Relay Requirements (Rq. 2.06)**

Using the test cords, apply test voltage to the relay coil terminals. Adjust the spring adjusting nut until the relay operates positively at the required voltage. On relay units using a reset button, it may be necessary to adjust the reset adjusting spring to secure the positive action of the relay.

***#3.07 Temperature (Rq. 2.07)**

Hold the bulb of the thermometer against the part in question, covering the opposite side of the bulb with a piece of felt or the equivalent. If the temperature exceeds the specified limits, see that requirements 2.02, 2.03, and 2.06 are met. If these requirements are met and the temperature is still above the specified limits, refer the matter to the supervisor as the relay may have to be replaced.

Note: Temperature measurements of the relay coil shall be made after the coil has been energized on maximum voltage for 15 seconds and of the contacts after they have reached ultimate temperature when carrying rated current continuously. See Table A below.

Table A

	<u>Relay Ratings</u>	
	<u>Max. Coil Voltage</u>	<u>Rated Contact Amps.††</u>
<u>KS-15623</u>		
List 1	28	4
List 2	36†	4

†Use highest voltage available (under 36 volts) if starting battery will not furnish 36 volts.

††The 4-ampere current can be secured by placing two of the 4-ohm resistors in series with the 32-volt test potential and the contacts under test.

CAUTION: Under trouble conditions, the temperature of the relay unit parts may exceed the specified limits. Never estimate temperature by touching with the fingers.