

MOTOR UNITS
LUBRICATION

| CONTENTS | PAGE |
|---|------|
| 1. GENERAL | 1 |
| 2. LUBRICATION | 2 |
| 14 AND 15 TYPE MOTOR UNITS | 2 |
| 28, 35, AND 37 TYPE MOTOR UNITS | 3 |
| Motor bearings — miniature motors | 3 |
| Motor bearings — standard motors | 3 |
| 32 AND 33 TYPE MOTOR UNITS | 4 |
| Motor bearings — miniature motors | 4 |
| GEAR TRAIN AND GOVERNOR | 5 |
| Gear train and governor assembly | 7 |

1. GENERAL

1.01 This section provides lubrication information for motor units used with various teletypewriters and associated apparatus. It is reissued to include engineering changes and additions, 14 and 15 type motor units, series governed motors, and variable speed gear train governor assembly. Since it is a general revision, marginal arrows used to indicate changes and additions have been omitted.

1.02 For complete lubrication of the pinion gear and intermediate gear assembly, refer to the section covering the application in which the motor is being used.

1.03 The motor ball bearings of the 28, 35, and 37 type motor units are packed with a wide range temperature lubricant by the manufacturer and normally will not require relubrication. However, if the motor is disassembled at any time, the bearings should be examined and

repacked, if required, with TKS103 grease (2.04 and 2.05). The bearings of the 32 and 33 type motors do not contain TKS103 grease and therefore must be lubricated with KS7470 oil (2.06). The lubricating interval is 750 consecutive operating hours or 3 months, whichever occurs first.

Note: The 28, 35, and 37 type motor units are furnished with ball type oilers or oil holes; however, they are not to be oiled or greased.

1.04 The exposed motor shaft should be covered with a thin film of grease to prevent rust.

1.05 The gear train and governor assembly uses KS7470 oil at all locations where the use of oil is indicated. Use KS7471 grease on all surfaces where grease is indicated.

1.06 The governor regulator gear train requires a thin film of grease on the teeth of each gear.

CAUTION: NOTE LOCATION OF NEEDLE TYPE AND BALL TYPE BEARINGS ON GOVERNOR SPUR GEAR ASSEMBLY (2.08) AND EXERCISE CARE IN DISASSEMBLING UNIT. MAKE SURE THAT BEARINGS ARE NOT LOST OR DAMAGED AND THAT UNIT OPERATES WITHOUT BINDING WHEN ASSEMBLED.

1.07 The governor should be lubricated after every 1500 hours of operation, or after 2000 adjustment cycles (governor speed changes using the "Slow-Fast" speed adjusting lever), whichever occurs first.

Note: Check governor brushes for wear; any accumulation of carbon dust should be removed.

1.08 The following list of symbols applies to the specific lubrication instructions shown in the line drawings:

| <u>Symbol</u> | <u>Meaning</u> |
|---------------|---------------------------|
| 02 | Apply 2 drops of oil |
| 06 | Apply 6 drops of oil |
| G | Apply thin film of grease |

2. LUBRICATION

14 AND 15 TYPE MOTOR UNITS

2.01 Motor Bearings: Depress ball oilers (2) with nozzle of grease gun and lubricate bearings with one stroke of the plunger. Run

motor for a few minutes to work out excess grease. Stop motor and wipe off excess grease.

CAUTION: TOO MUCH GREASE CAUSES STARTING SWITCH TROUBLE ON THE SYNCHRONOUS MOTORS, COMMUTATOR TROUBLE AND FALSE GROUNDING ON DC MOTORS, AND ON AC SERIES MOTORS.

2.02 Motor Pinon: Apply thin film of grease to prevent rust.

2.03 Motor Speed Adjusting Lever (Governed Motors): Apply oil on pilot screw.

28, 35, AND 37 TYPE MOTOR UNITS

CAUTION: DO NOT USE GREASE GUN ON MOTOR UNITS.

2.04 Motor Bearings — Standard Motors

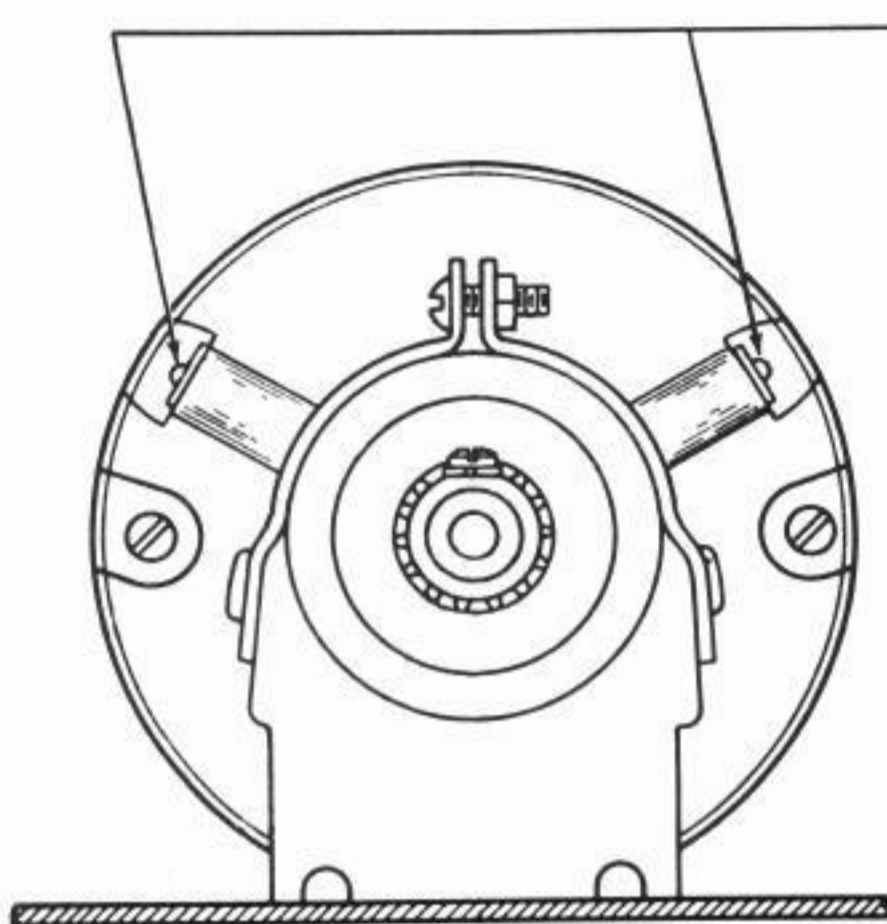

Ball Oilers

(Motors are furnished with ball type oilers; however, they are not to be oiled. Motor ball bearings are packed with a wide range temperature TKS103 grease.)

2.05 Motor Bearings — Miniature Motors

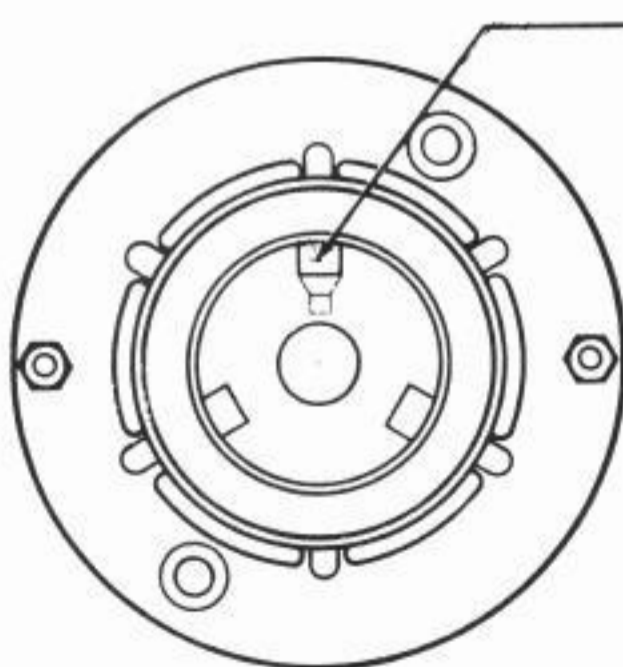

Oil Hole

(Motors are furnished with oil holes; however, they are not to be oiled. Motor ball bearings are packed with a wide range temperature TKS103 grease.)

32 AND 33 TYPE MOTOR UNITS

2.06 Motor Bearings — Miniature Motors

CAUTION: DO NOT USE GREASE GUN ON MOTOR UNITS.

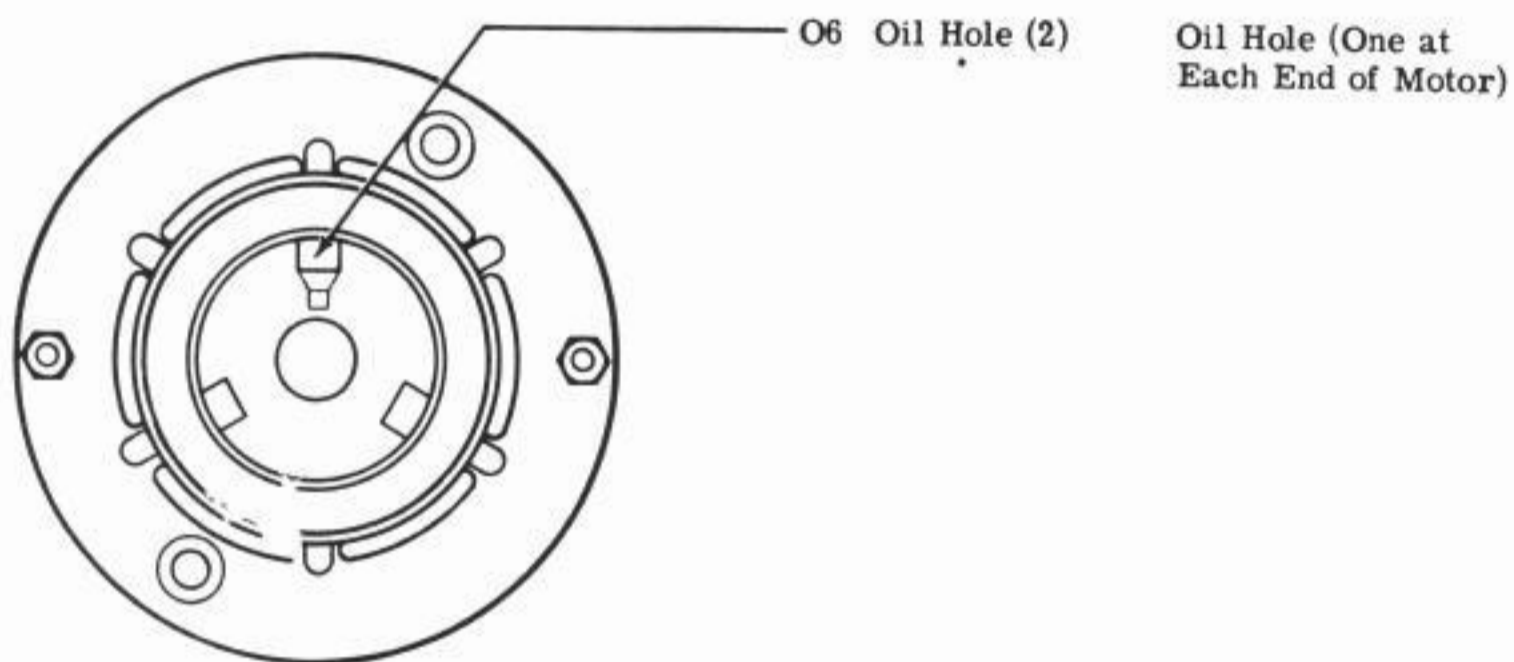

GEAR TRAIN AND GOVERNOR

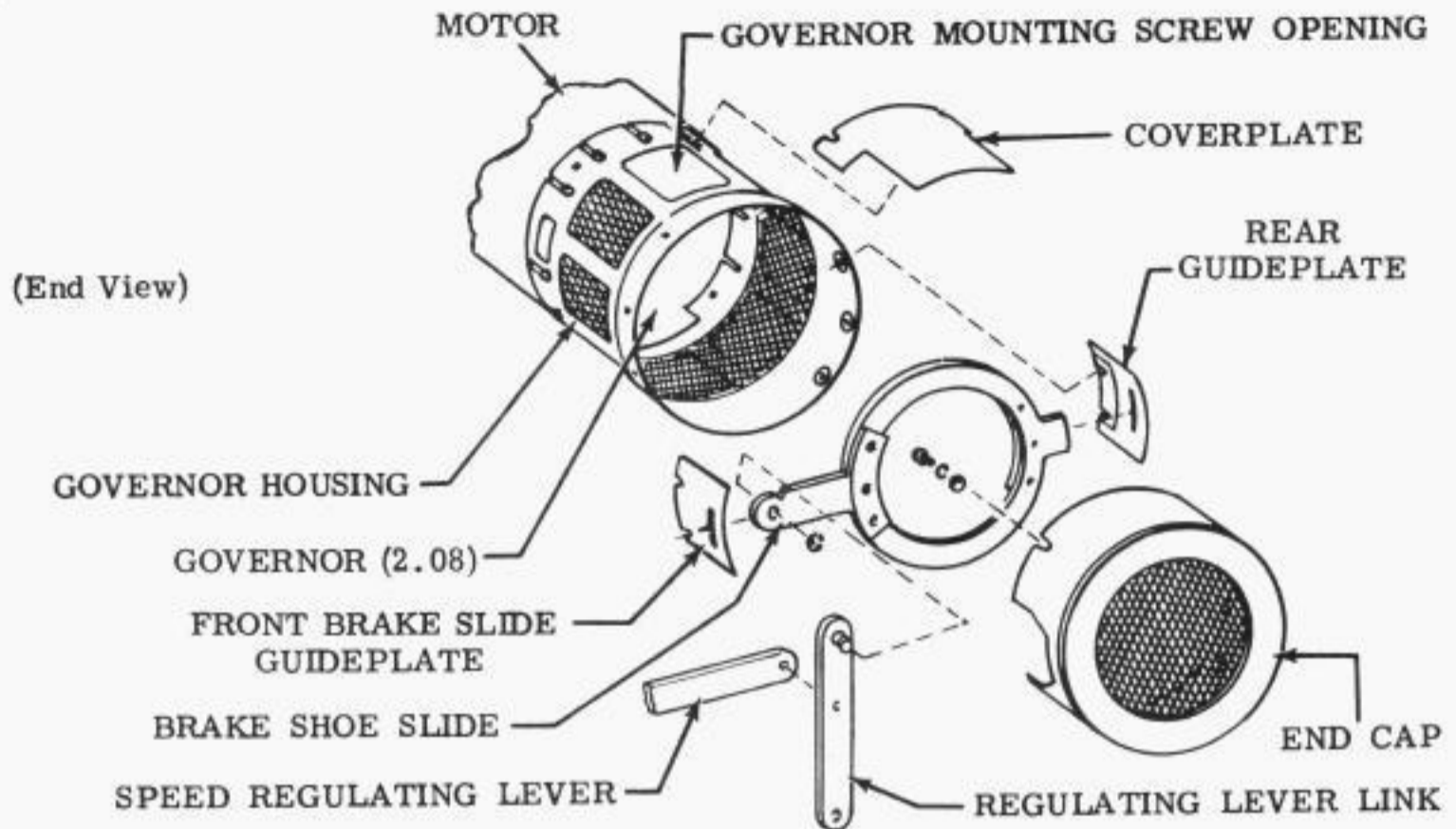

2.07 To lubricate gear train and governor assembly:

- (1) Remove end cap of governor housing with its mounting screws (4) loosened.
- (2) Remove front and rear guideplates of brake shoe slide; remove the retaining ring that secures the regulating lever link with brake shoe slide.
- (3) Remove coverplate from top of governor housing; remove governor mounting screw, and slide governor out of housing.
- (4) Remove brake discs from center shaft by removing its retaining ring and sliding disc assembly outward. Apply grease to shaft and bearing (2.08).

CAUTION: AVOID LOSS OF NEEDLE BEARINGS IN HANDLING.

- (5) Remove spur gear plate assembly by removing its mounting screws (4) attached to respective posts. Grease the worm gear bearing (located opposite shaft driving gear) (2.08).

CAUTION: AVOID LOSS OF BALL BEARING IN HANDLING.

- (6) Remove worm gear driving (spur) gear by removing retaining ring from worm gear shaft. Remove ball bearing, fill cavity with grease and replace bearing. Wipe off excessive grease and replace spur gear (2.08).

CAUTION: EXERCISE CARE IN HANDLING BEARINGS.

- (7) Remove remaining spur gears (3) by removing respective bearing rings. Grease upper front gear bearing and apply oil to lower left and right gear bearings as directed. Replace bearing rings (3).

SECTION 570-220-701TC

- (8) Rotate worm gear manually to expose threads of spring tension adjusting screw. Grease threads inside governor spring assembly.
- (9) Remove adjusting screw drive gear by removing its locknut and lockwasher. Grease bearing surface of spring assembly and replace parts. Push adjusting screw downward to expose bearing surface while greasing.
- (10) Apply thin film of grease to teeth of all gears in the assembly.
- (11) Recheck spur gear requirements given in Section 570-220-700TC, replace the spur gear plate assembly and grease the center post.
- (12) Replace the shims on center post, slide the disc assembly in place and secure by the retaining ring.
- (13) Check for wear of governor brushes, replace if necessary. Hold brushes away from motor shaft and slide governor assembly in place. Reposition the brushes on the slip rings.
- (14) Replace brake shoe slide assembly and governor housing in the reverse order. Exercise care to make sure that all components move freely and all coverplates, etc are secured to shut out rfi noise.

2.08 Gear Train and Governor Assembly

