

32 AND 33 TYPING UNIT

LUBRICATION

CONTENTS	PAGE	CONTENTS	PAGE
1. GENERAL . . . . .	1	Stop bail . . . . .	4
2. BASIC UNITS . . . . .	2	Trip lever . . . . .	3
COMMON MECHANISMS . . . . .	2	Trip shaft . . . . .	5
Armature . . . . .	7	Typewheel mechanism . . . . .	15
Automatic codebar . . . . .	8	FRICITION FEED MECHANISMS . . . . .	18
Blocking levers . . . . .	8	Line feed mechanism . . . . .	19
Carriage area . . . . .	13	Paper feed area . . . . .	18
Carriage return and spacing levers . . . . .	11	Platen . . . . .	18
Codebars . . . . .	9	SPROCKET FEED MECHANISMS . . . . .	19
Codebar clutch . . . . .	5	Cam, pulley, and gear combination . . . . .	21
Dashpot . . . . .	13	Form-out mechanism . . . . .	22
Disc and brushes . . . . .	3	Line feed clutch . . . . .	22
Distributor area . . . . .	2	Paper feed area . . . . .	19
Drive mechanism . . . . .	12	Platen mechanism . . . . .	20
Function area . . . . .	8	Platen drive area . . . . .	21
Function clutch . . . . .	5	3. VARIATIONS TO BASIC UNITS . . . . .	23
Function levers . . . . .	10	Answer-back area . . . . .	23
Intermediate gears . . . . .	17	Answer-back mechanism . . . . .	24
Latchlever . . . . .	3	Trip magnet . . . . .	23
Latchlever and trip lever . . . . .	6	1. GENERAL	
Main shaft area . . . . .	4	1.01 This section is issued to provide in-	
Motor . . . . .	17	structions for lubricating the 32 and 33	
Motor area . . . . .	17	typing unit and to present the lubricating in-	
Print hammer . . . . .	14	structions as a separate section.	
Push levers and stripper ball . . . . .	7	1.02 The general lubrication areas are illus-	
Reset arm . . . . .	14	trated by photographs. The specific	
Reset bail . . . . .	9	points to receive lubricant are indicated on	
Ribbon guide spring . . . . .	15	line drawings with appropriate textual instruc-	
Ribbon mechanism . . . . .	16	tions. Line drawings and textual instructions	
Rocker and pawls . . . . .	9	follow each photograph and are keyed to the	
Selector area . . . . .	6	photograph by paragraph numbers.	
Selector clutch . . . . .	6		
Selector levers . . . . .	7		
Slides . . . . .	16		
Slide guide plates - 1 . . . . .	14		
Slide guide plates - 2 . . . . .	15		
Spacing area . . . . .	10		
Space bellcrank . . . . .	10		
Spacing mechanism - 1 . . . . .	11		
Spacing mechanism - 2 . . . . .	12		

SECTION 574-122-701

1.03 Thoroughly lubricate the typing unit, but avoid over lubrication that might permit the lubricant to drip or be thrown onto adjacent parts. Saturate all felt washers and oilers with oil, and apply oil to each end of all bearings. Use KS7470 Oil where oil is required and KS7471 Grease where grease is required.

1.04 Lubricate the typing unit before placing it into service or prior to storage. After a short period of service, relubricate it to make sure no areas have been missed. Thereafter, lubricate the typing unit at regular intervals as indicated below:

<u>Operating Speed (Words per Minute)</u>	<u>Lubrication Interval</u>
60 or 66	1000 hr* or 1 yr**
100	500 hr* or 6 mo**

\*Station Set operating hours.  
\*\*Whichever comes first.

1.05 The textual instructions that accompany the line drawings consist of abbreviated directions, specific lubrication points, and parts affected. The meanings of the abbreviated directions (symbols) follow:

<u>Symbol</u>	<u>Meaning</u>
D	Keep dry - no lubricant permitted
G	Apply thin coat of KS7471 Grease

<u>Symbol</u>	<u>Meaning</u>
GOL	Brush on well a mixture of 50% KS7471 Grease and 50% KS7470 Oil
OL	Oil liberally (3 or more drops)
OS	Oil sparingly (1 or 2 drops only)
OSAT	Saturate with oil (felt washers and oilers)
OSD	Oil sparingly or leave dry**
OSL	Oil sparingly or liberally

\*\*Applies to all areas not contacted by other parts.

1.06 References to "left," "right," "front," or "rear," etc consider the typing unit to be viewed from a position where the carriage area faces up and the selector area is located to the viewer's left.

**CAUTION:** DO NOT USE ALCOHOL, MINERAL SPIRITS, OR OTHER SOLVENTS TO CLEAN PLASTIC PARTS OR PARTS WITH PROTECTIVE-DECORATIVE FINISHES. NORMALLY, A SOFT, DRY CLOTH SHOULD BE USED TO REMOVE DUST, OIL, GREASE, OR OTHERWISE CLEAN PARTS OR SUBASSEMBLIES. IF NECESSARY, A SOFT CLOTH DAMPENED WITH SOAP OR MILD DETERGENT MAY BE USED. AFTERWARDS, RINSE EACH CLEANED PART OR SUBASSEMBLY WITH SOFT, DAMP CLOTH AND BUFF WITH A SOFT, DRY CLOTH.

2. BASIC UNITS

COMMON MECHANISMS

2.01 Distributor Area

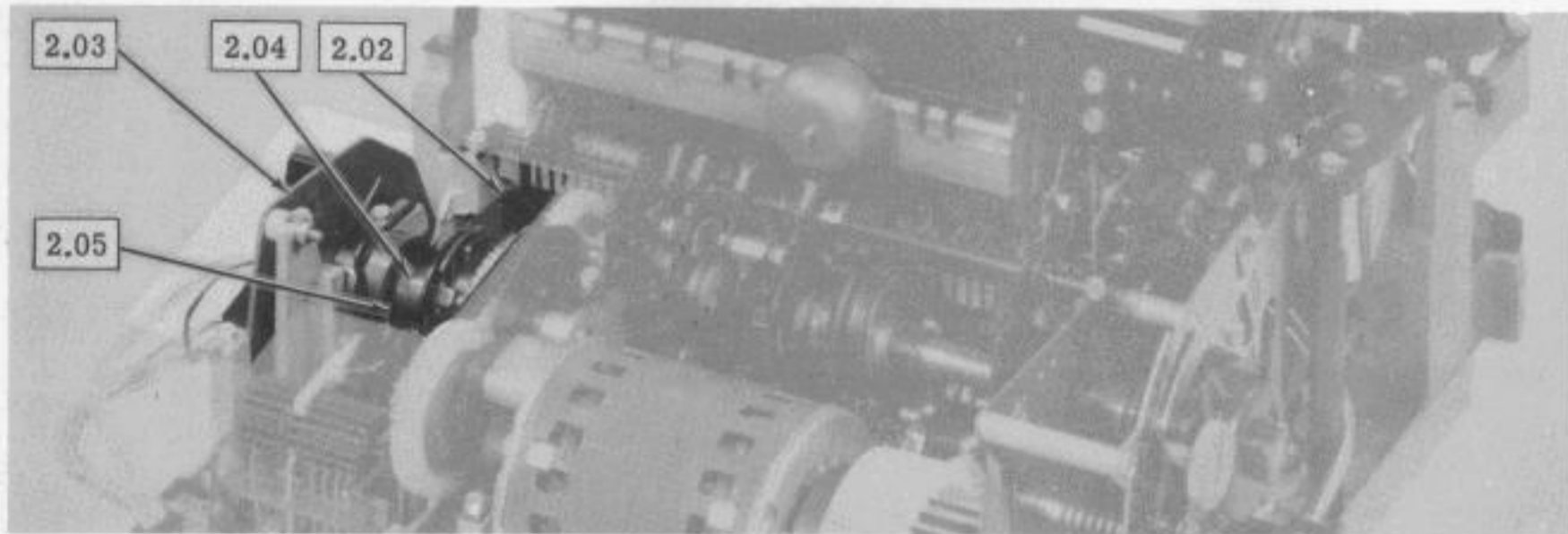

(LEFT REAR VIEW)

2.02 Trip Lever

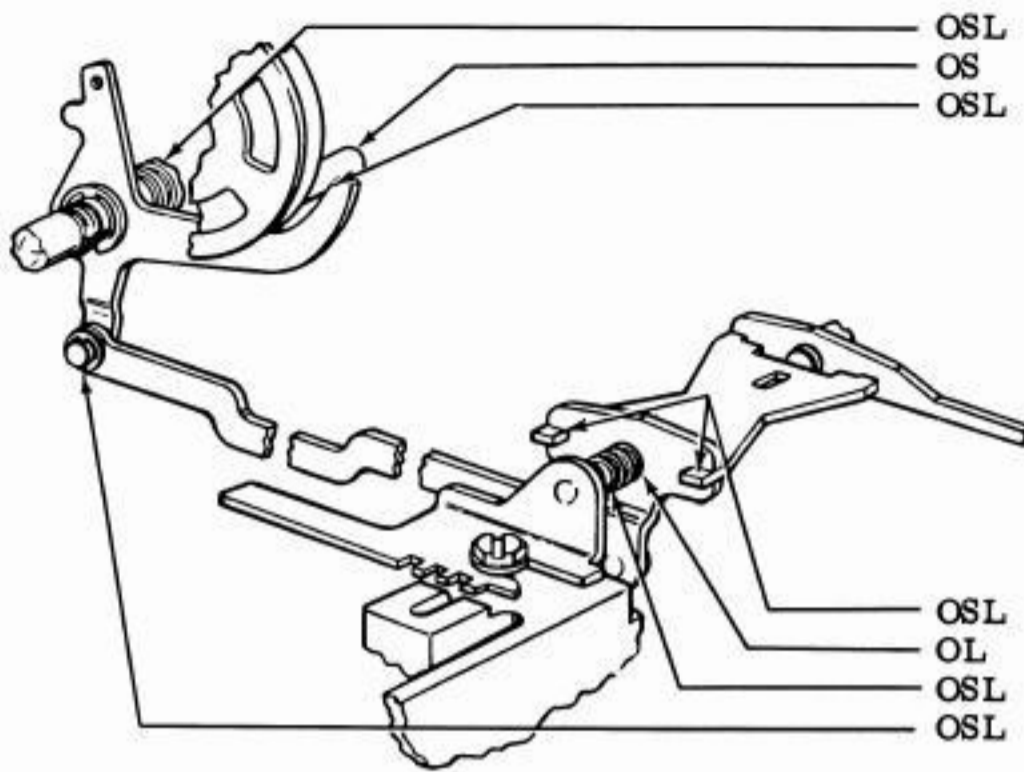

- |     |                   |                 |
|-----|-------------------|-----------------|
| OSL | Pivot             | Trip Shaft      |
| OS  | Shaft (Both Ends) | Roller          |
| OSL | Sliding Surface   | Roller Follower |
| OSL | Engaging Tabs     | H-Lever         |
| OL  | Pivot             | H-Lever         |
| OSL | Seat (Each End)   | H-Lever Spring  |
| OSL | Pivot             | Trip Lever      |

(LEFT FRONT VIEW)

2.03 Disc and Brushes

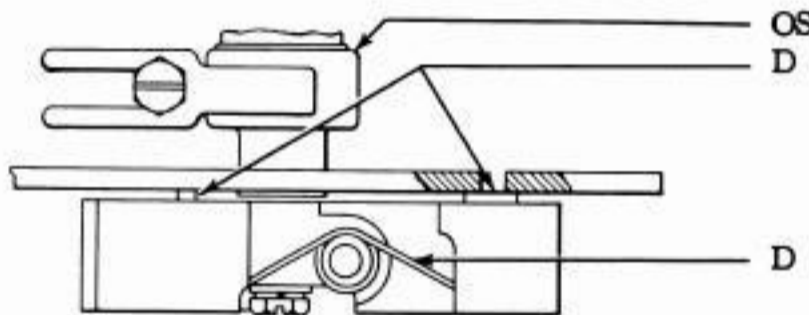

- |    |                     |                   |
|----|---------------------|-------------------|
| OS | Bearings (Each End) | Distributor Shaft |
| D  | Contact Surfaces    | Disc and Brushes  |
| D  | Seat or Ends        | Spring            |

(TOP VIEW)

2.04 Latchlever

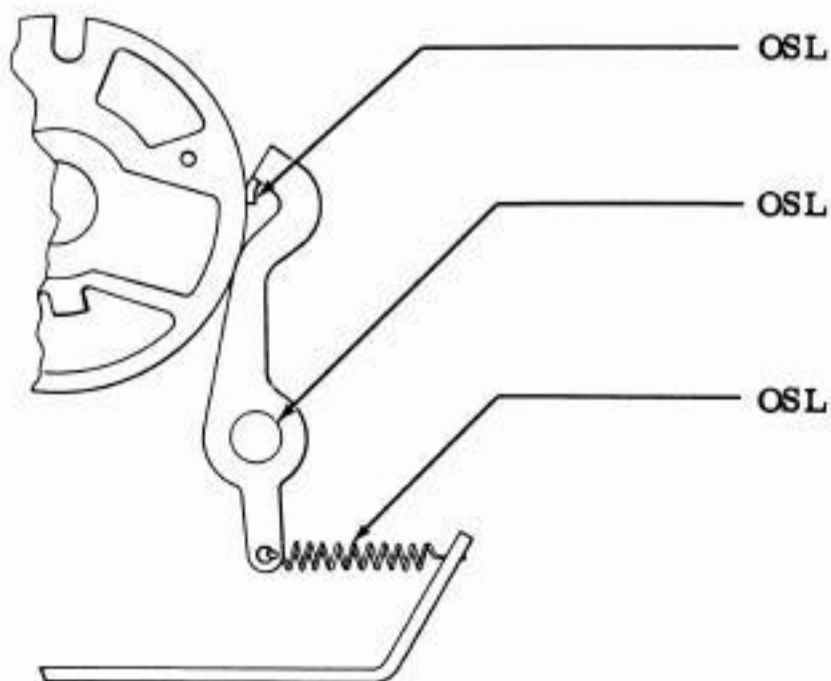

- |     |                  |            |
|-----|------------------|------------|
| OSL | Latching Surface | Latchlever |
| OSL | Pivot            | Trip Shaft |
| OSL | Hooks (Each End) | Spring     |

(RIGHT SIDE VIEW)

2.05 Stop Bail

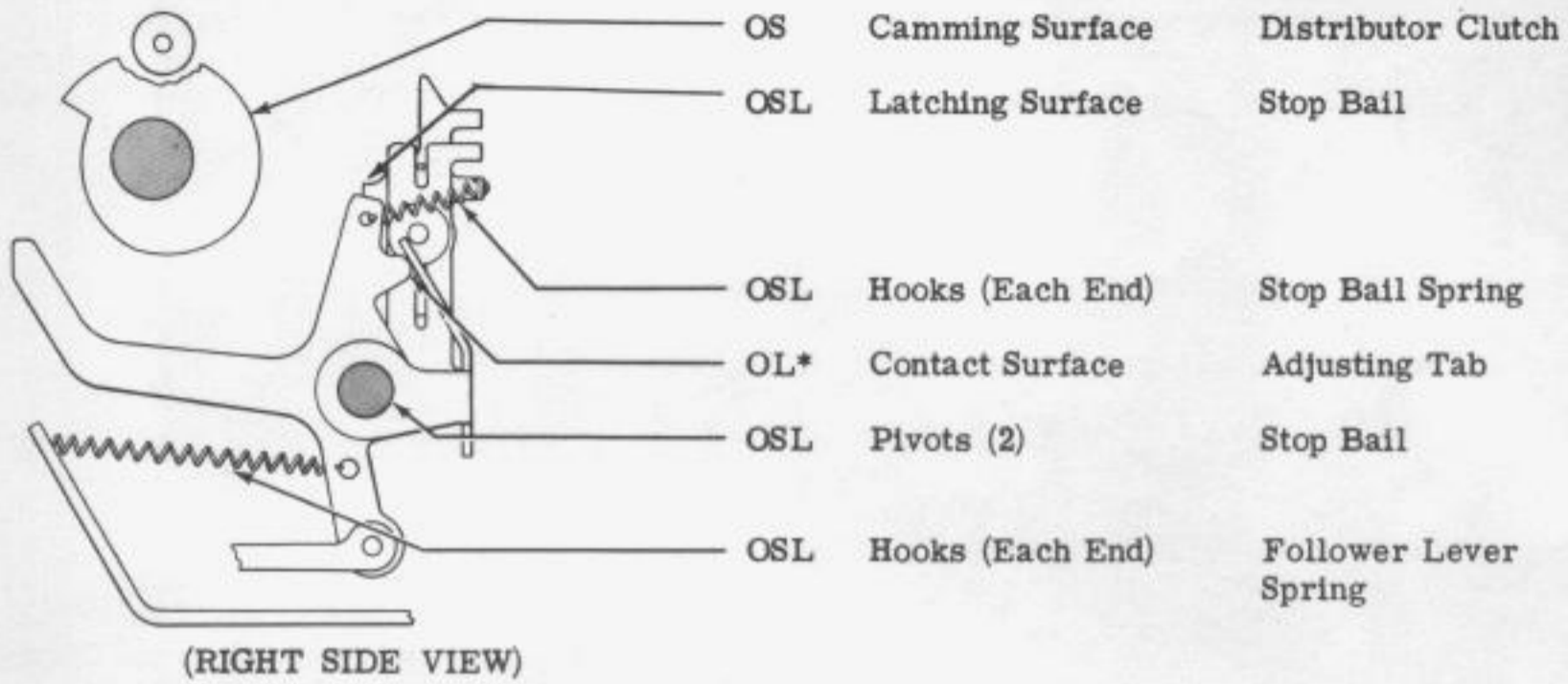

\*GOL when assembly is overhauled.

2.06 Main Shaft Area

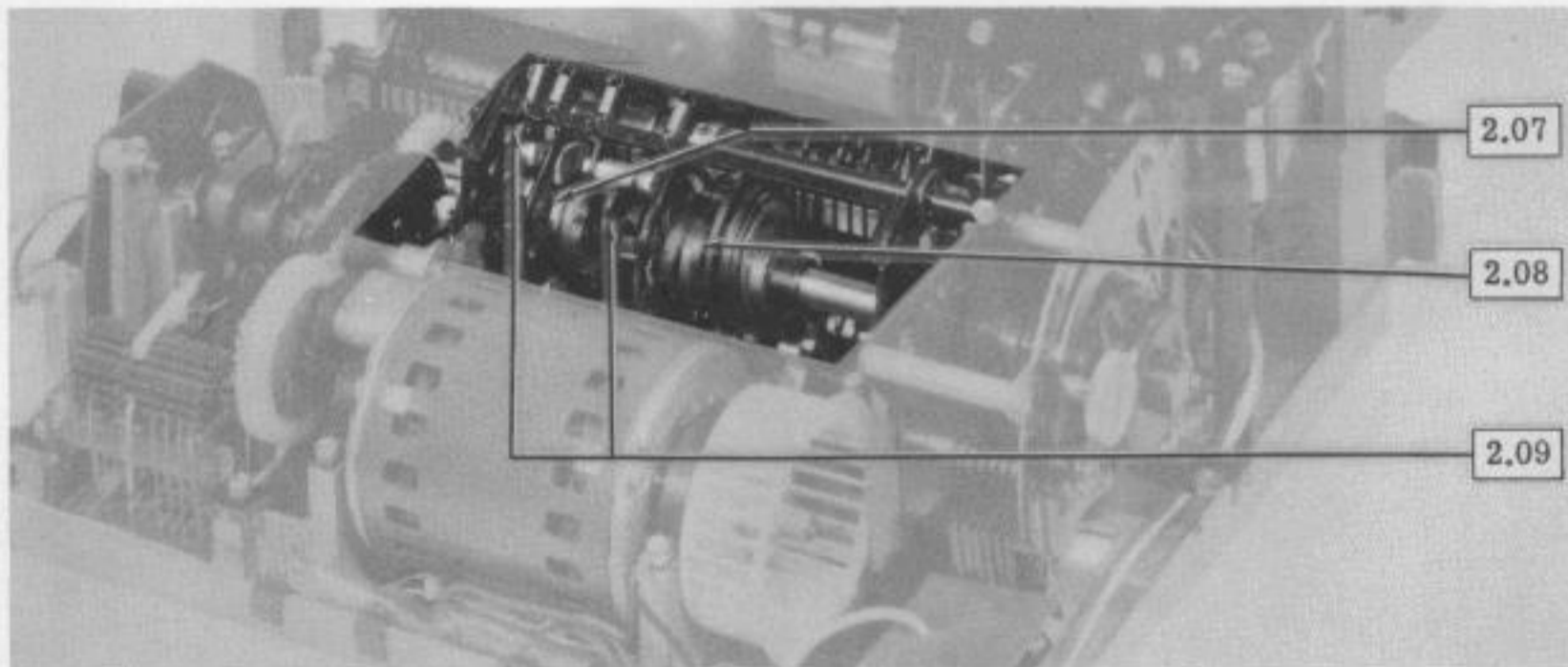

(LEFT REAR VIEW)

2.07 Codebar Clutch

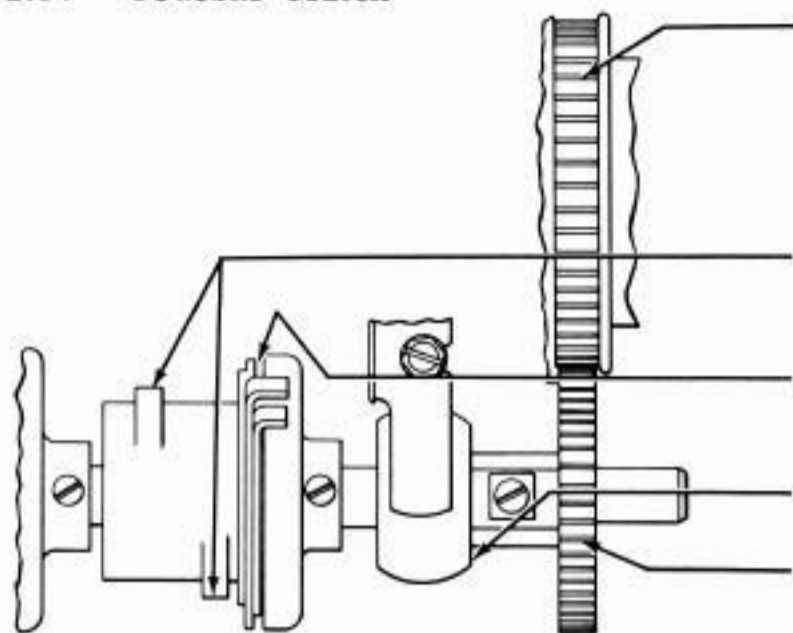

(TOP VIEW)

- |     |  |                  |
|-----|--|------------------|
| G   | Teeth  | Distributor Gear |
|     | (Do not grease teeth of motor belt sprocket) |                  |
| OL* | Camming Surfaces                             | Eccentric Cams   |
| OSD | Interior Mechanism                           | All Clutches     |
| OS  | Bearings (Both Ends)                         | Main Shaft       |
| G   | Teeth  | Gear             |

2.08 Function Clutch

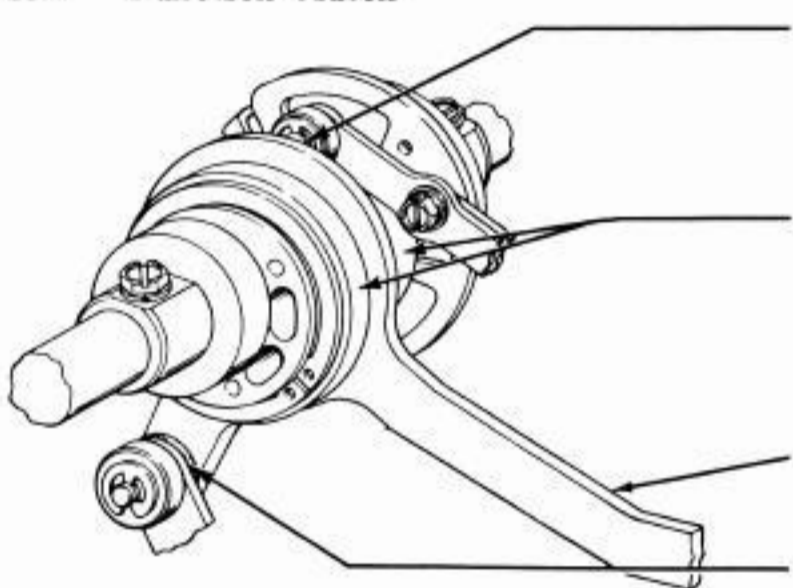

(LEFT FRONT VIEW)

- |      |                  |                    |
|------|------------------|--------------------|
| OS   | Shaft (Each End) | Roller             |
| OL*  | Camming Surfaces | Eccentric Cams     |
| OSL  | Sliding Surface  | Carriage Drive Arm |
| OSAT | Felt Washer      | Function Drive Arm |

2.09 Trip Shaft

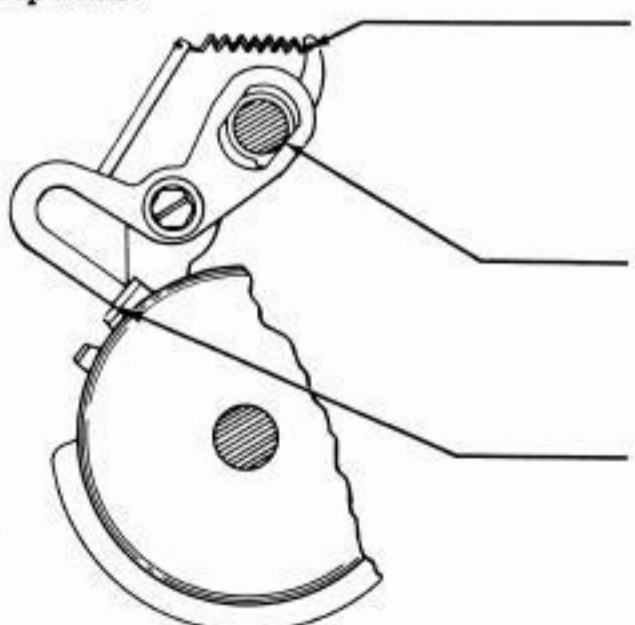

(LEFT SIDE VIEW)

- |     |                  |                  |
|-----|------------------|------------------|
| OSL | Hooks (Each End) | Springs (4)      |
| OL* | Pivot Bearings   | Shaft (6 Points) |
| OSL | Latching Surface | Trip Lever (2)   |

\*GOL when assembly is overhauled.

2.10 Selector Area

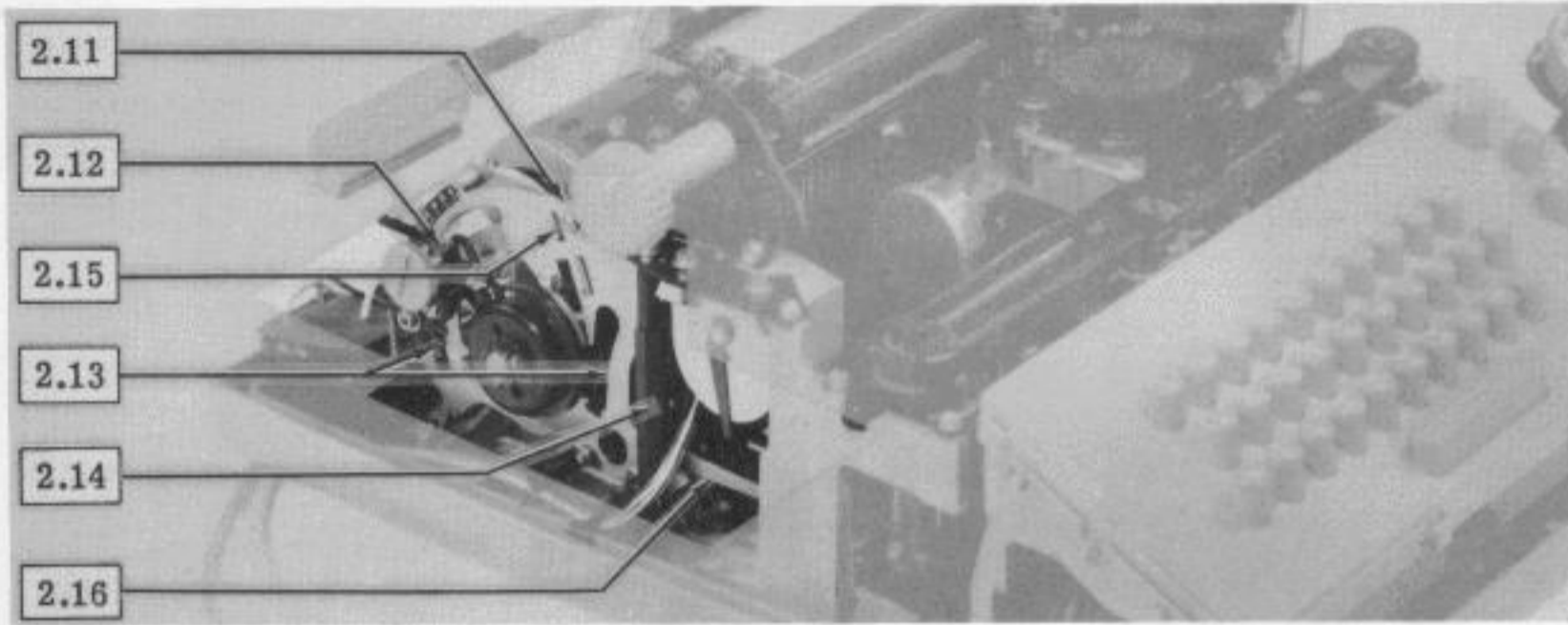

(LEFT SIDE VIEW)

2.11 Selector Clutch

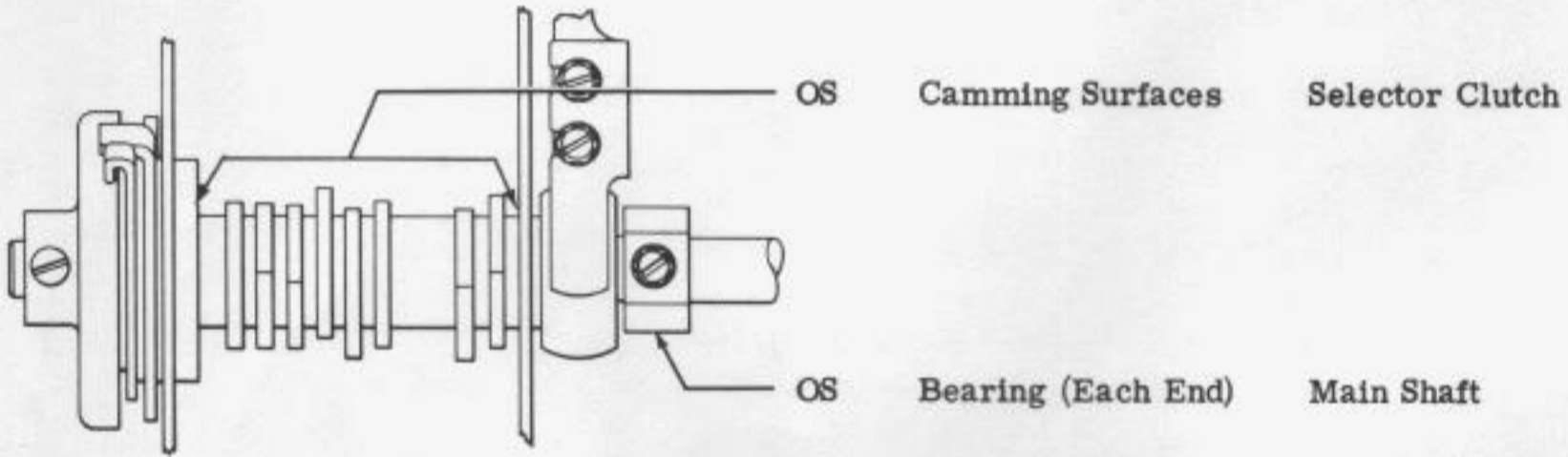

(TOP VIEW)

2.12 Latchlever and Trip Lever

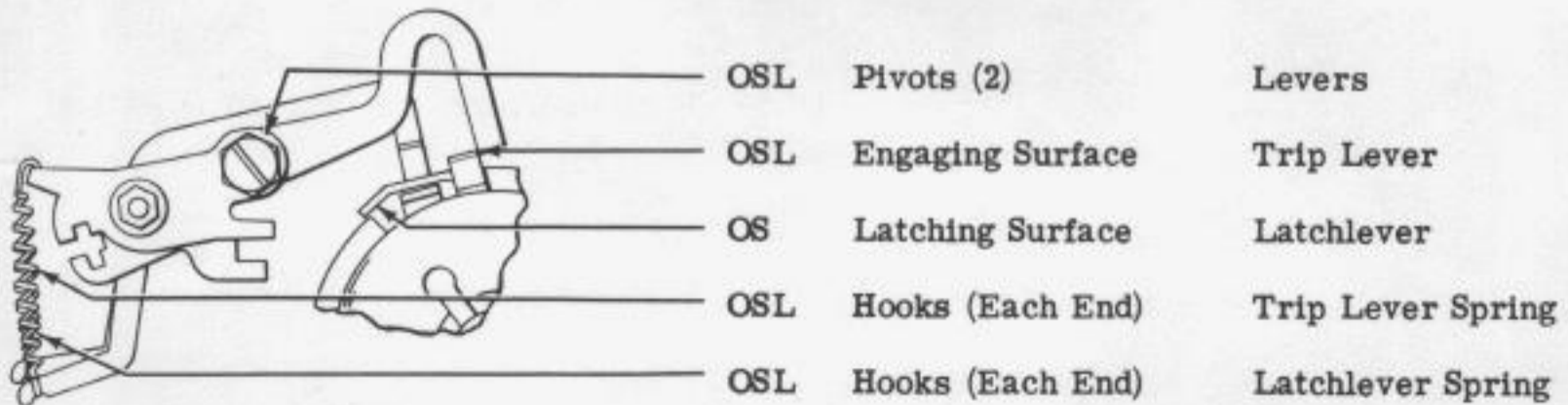

(LEFT SIDE VIEW)

2.13 Selector Levers

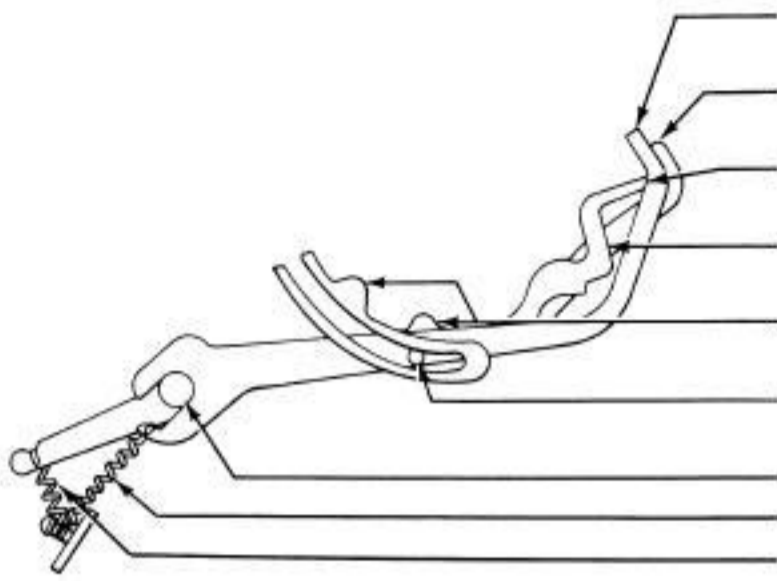

- |     |                    |                     |
|-----|--------------------|---------------------|
| G   | (After Oiling) Tip | Start Lever         |
| OS  | Contact Surface    | Locklever           |
| OS  | Contact Surface    | Selector Levers (6) |
| OSL | Engaging Surface   | Selector Levers (6) |
| OL* | Camming Surface    | Selector Levers (6) |
| OSL | Sliding Contact    | Start Lever         |
| OSL | Pivots (8)         | Levers              |
| OSL | Hooks (Each End)   | Start Lever Spring  |
| OSL | Hooks (Each End)   | Springs (6)         |

(LEFT SIDE VIEW)

2.14 Push Levers and Stripper Bail

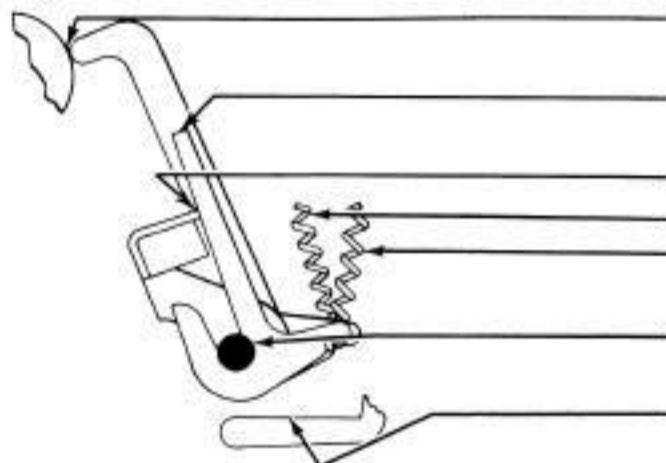

- |     |                  |                        |
|-----|------------------|------------------------|
| OL* | Camming Surface  | Cam Follower           |
| OSL | Latching Surface | Push Levers (6)        |
| OSL | Contact Surface  | Stripper Bail          |
| OSL | Hooks (Each End) | Bail Spring            |
| OSL | Hooks (Each End) | Push Lever Springs (6) |
| OSL | Pivots (6)       | Push Levers            |
| OSL | Contact Surfaces | Blocking Levers (6)    |

(LEFT SIDE VIEW)

2.15 Armature

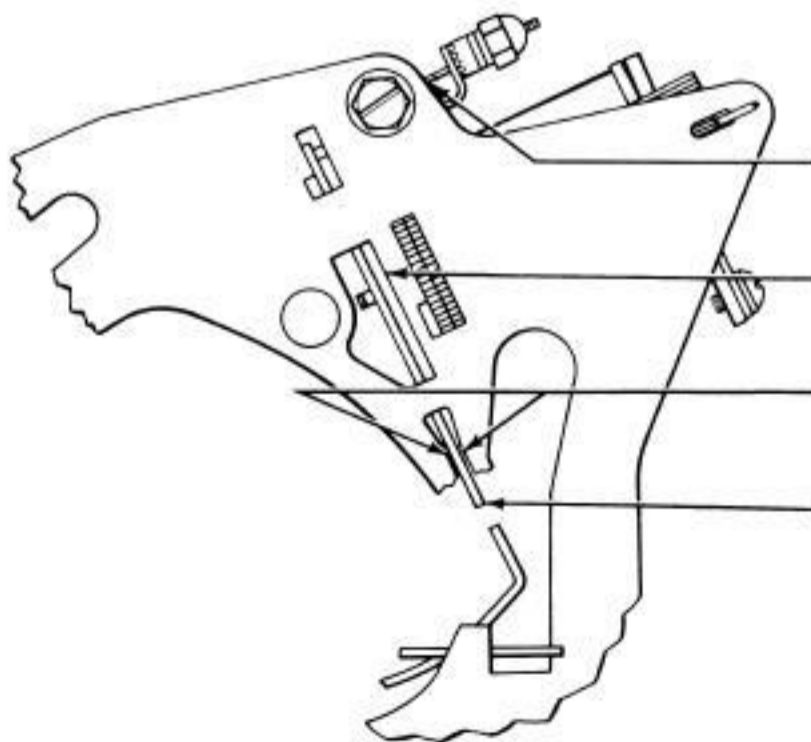

- |     |                   |                 |
|-----|-------------------|-----------------|
| D   | Hooks             | Armature Spring |
| D   | Engaging Surfaces | Armature        |
| OSD | Engaging Surfaces | Side Plates     |
| G   | Engaging Surface  | Armature        |

(LEFT SIDE VIEW)

\*GOL when assembly is overhauled.

2.16 Blocking Levers

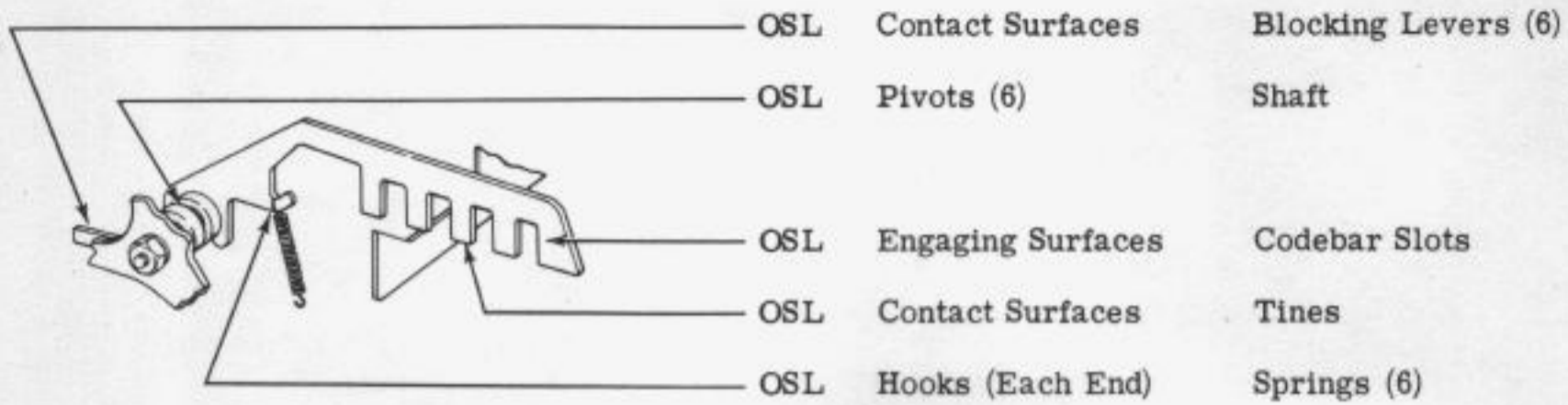

(LEFT FRONT VIEW)

2.17 Function Area

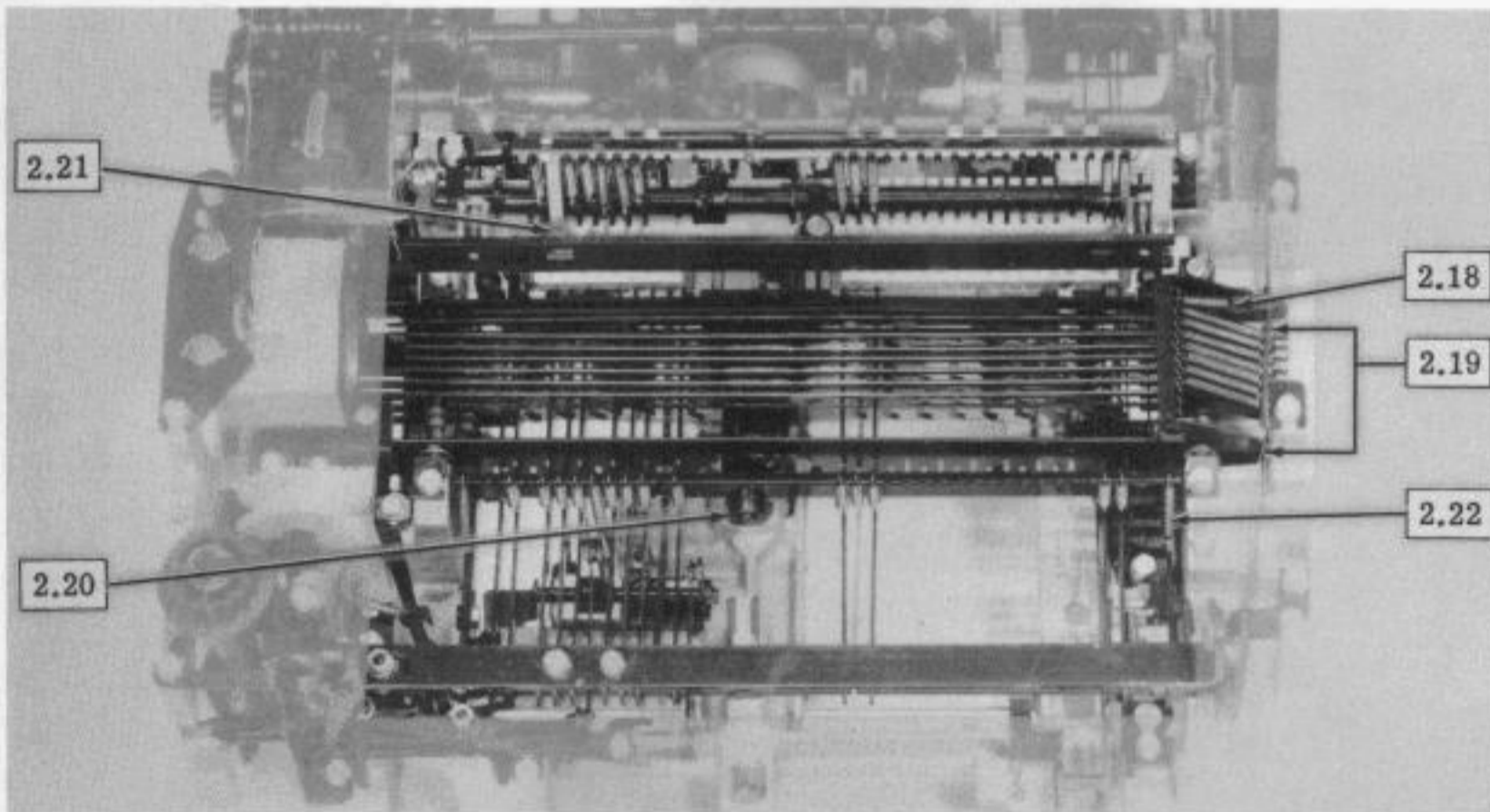

(TOP VIEW)

(Platen and carriage removed for illustration purposes.  
Removal for lubrication is not required.)

2.18 Automatic Codebar

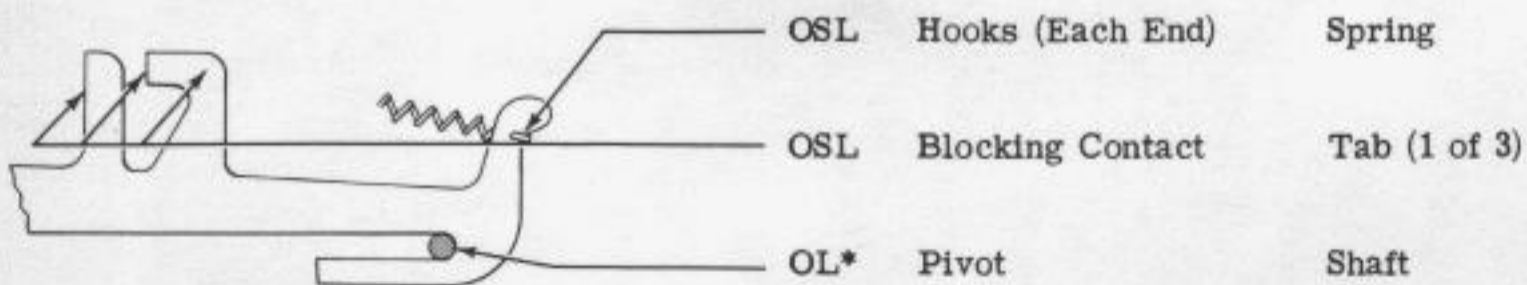

(FRONT VIEW)

\*GOL when assembly is overhauled.



2.19 Codebars

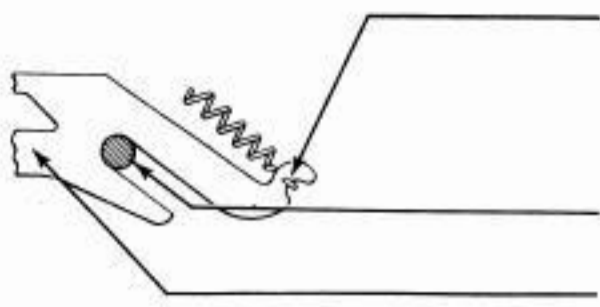

(FRONT VIEW)

- |     |                       |             |
|-----|-----------------------|-------------|
| OSL | Hooks (Each End)      | Springs (7) |
| OL* | Pivots (7)            | Shaft       |
| D   | Area Between Codebars |             |

\*GOL when assembly is overhauled.

2.20 Reset Bail

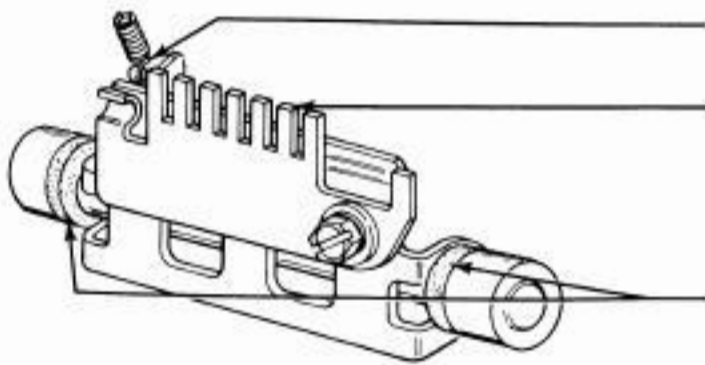

(LEFT FRONT VIEW)

- |      |                  |                        |
|------|------------------|------------------------|
| OSL  | Hooks (Each End) | Spring                 |
| OSL  | Contact Surfaces | Codebar Engaging Tines |
| OSAT | Felt Washers (2) | Reset Bail Shaft       |

2.21 Rocker and Pawls

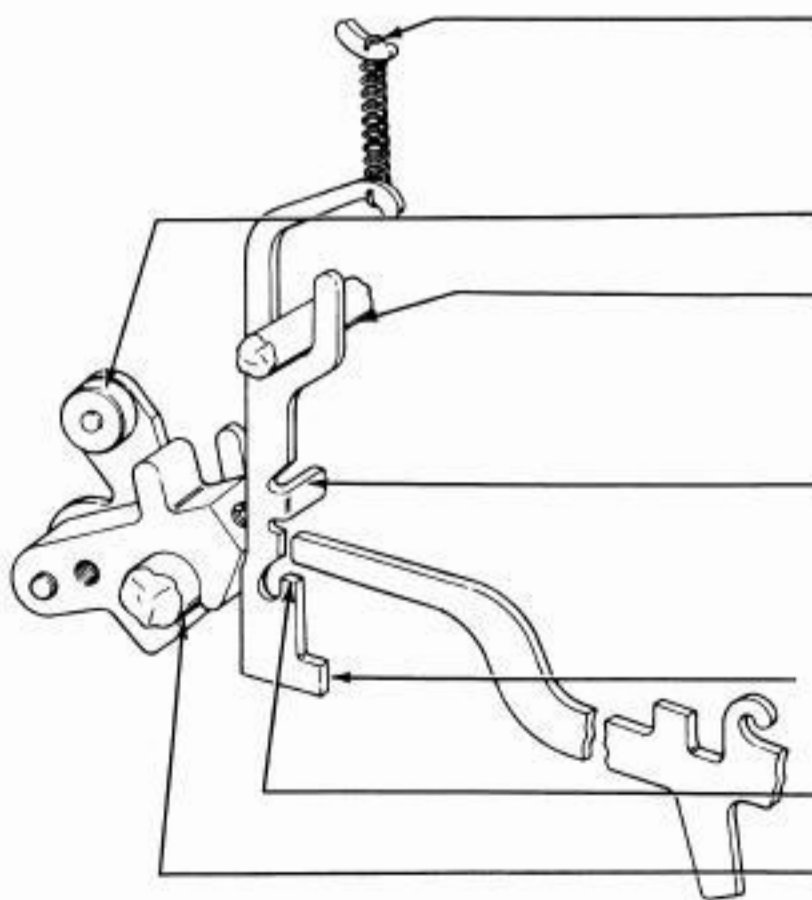

(LEFT FRONT VIEW)

- |     |                                    |                 |
|-----|------------------------------------|-----------------|
| OSL | Hooks (Each End)                   | Pawl Springs    |
| OSL | Pivot                              | Rocker Arm      |
| OSL | Pivots (11)                        | Shaft           |
| OSL | Latching Surfaces                  | Pawls           |
| OSL | Engaging Surfaces                  | Pawls           |
| OSL | Engaging Surfaces                  | Function Levers |
| OS  | Bearings and Pivots (Each End - 4) | Function Shaft  |

2.22 Function Levers

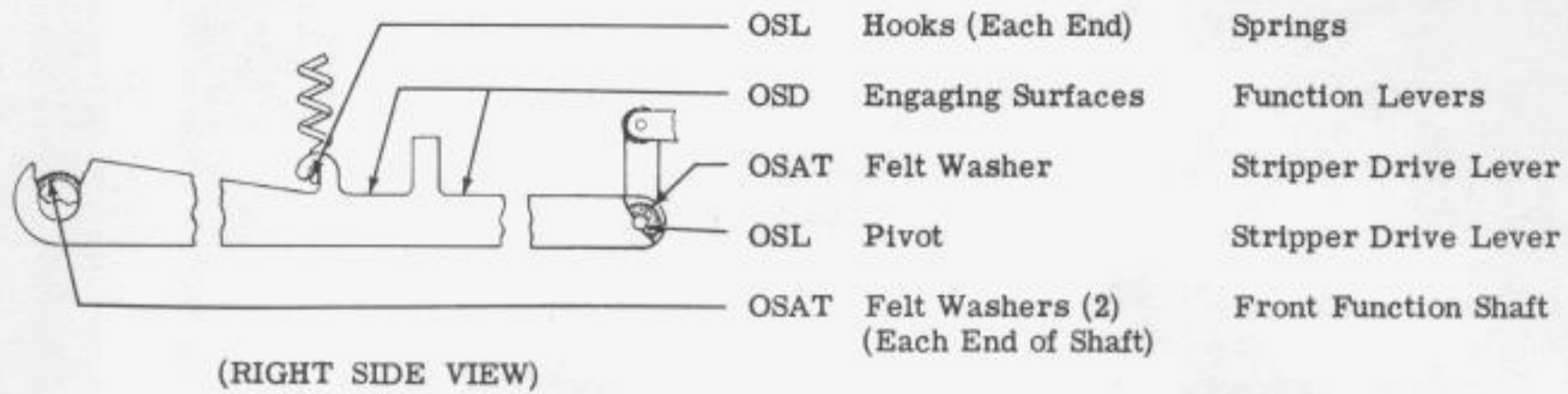

2.23 Spacing Area

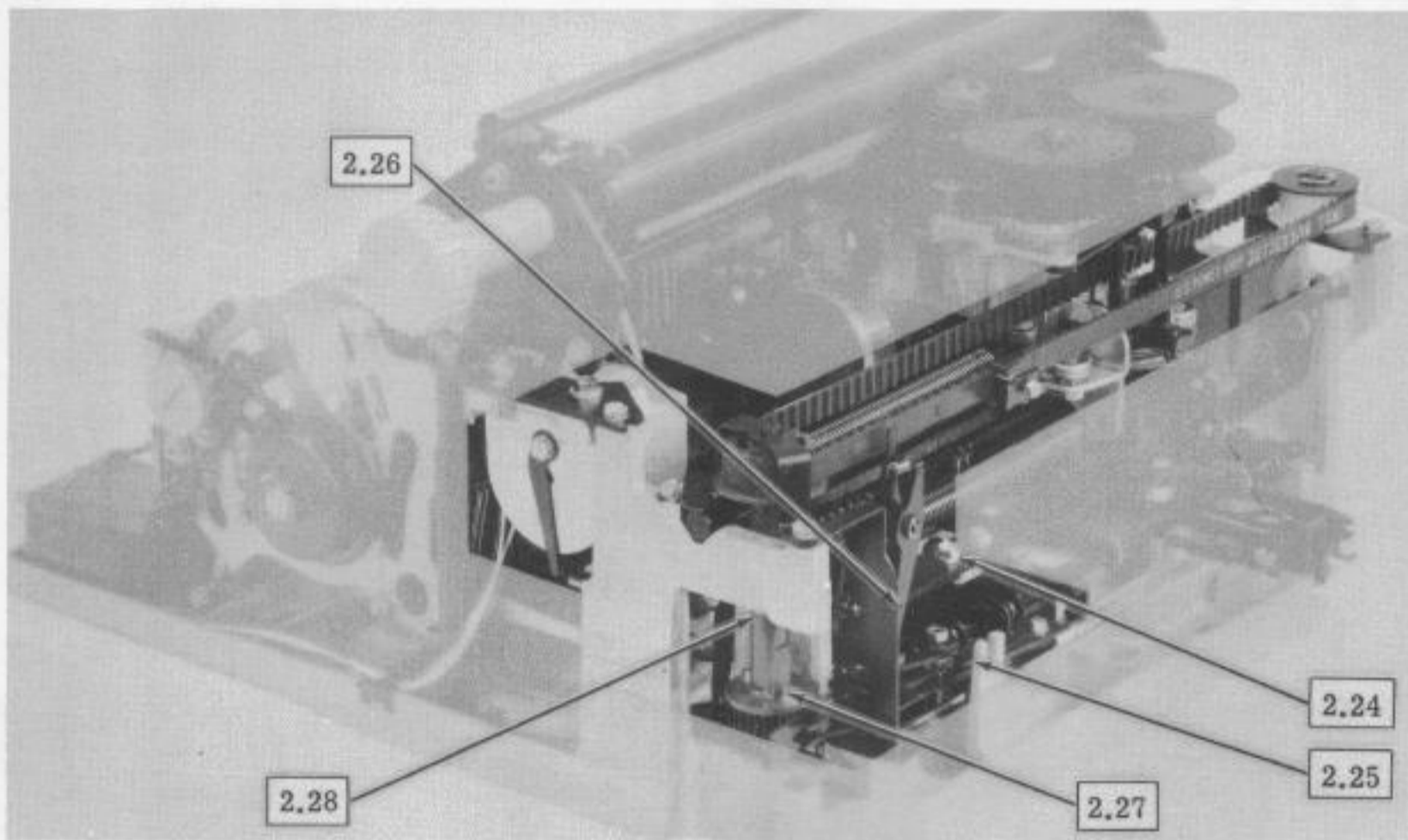

(LEFT FRONT VIEW)

2.24 Space Bellcrank

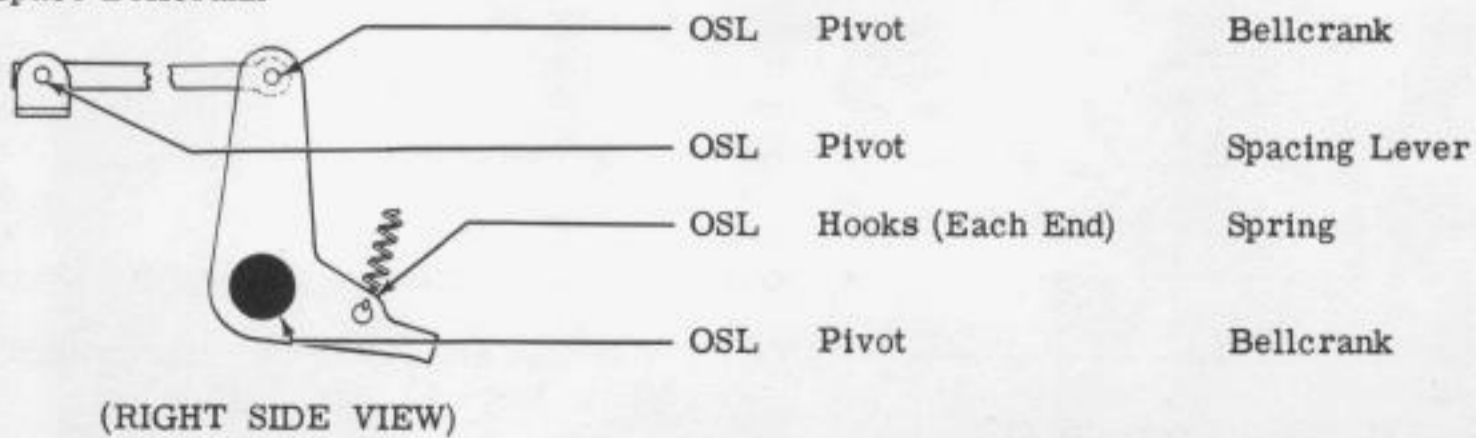

2.25 Carriage Return and Spacing Levers

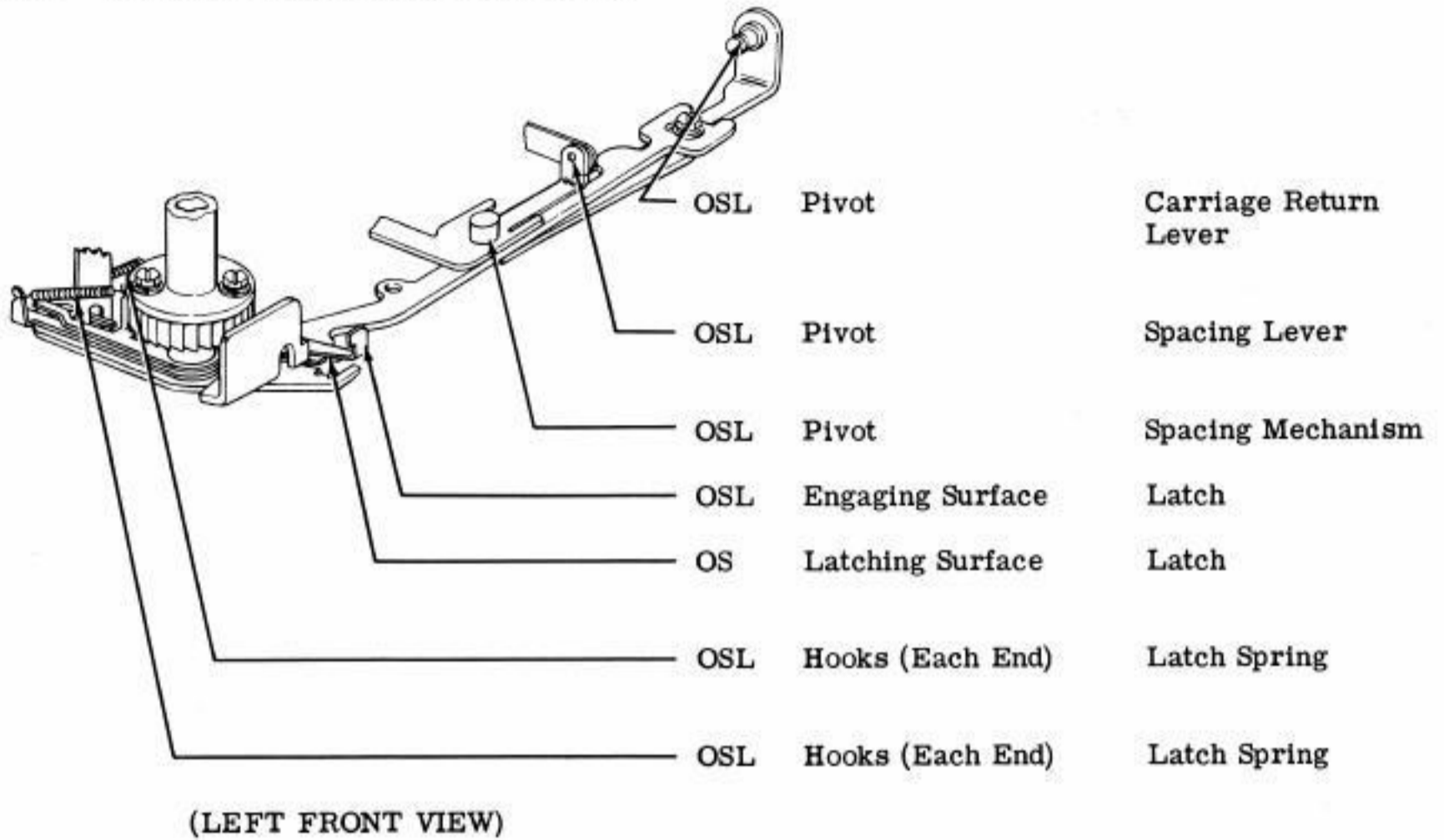

2.26 Spacing Mechanism - 1

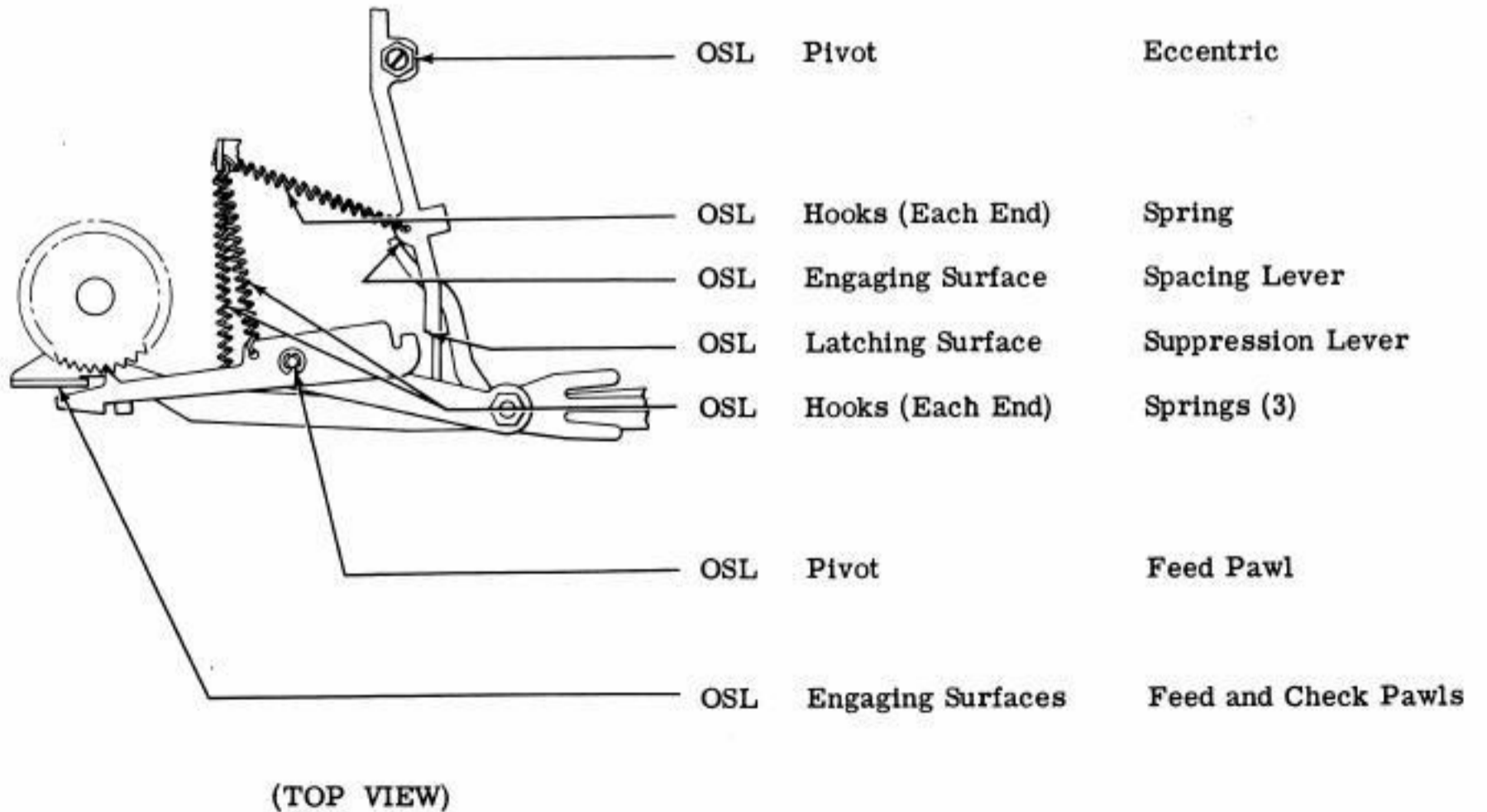

2.27 Drive Mechanism

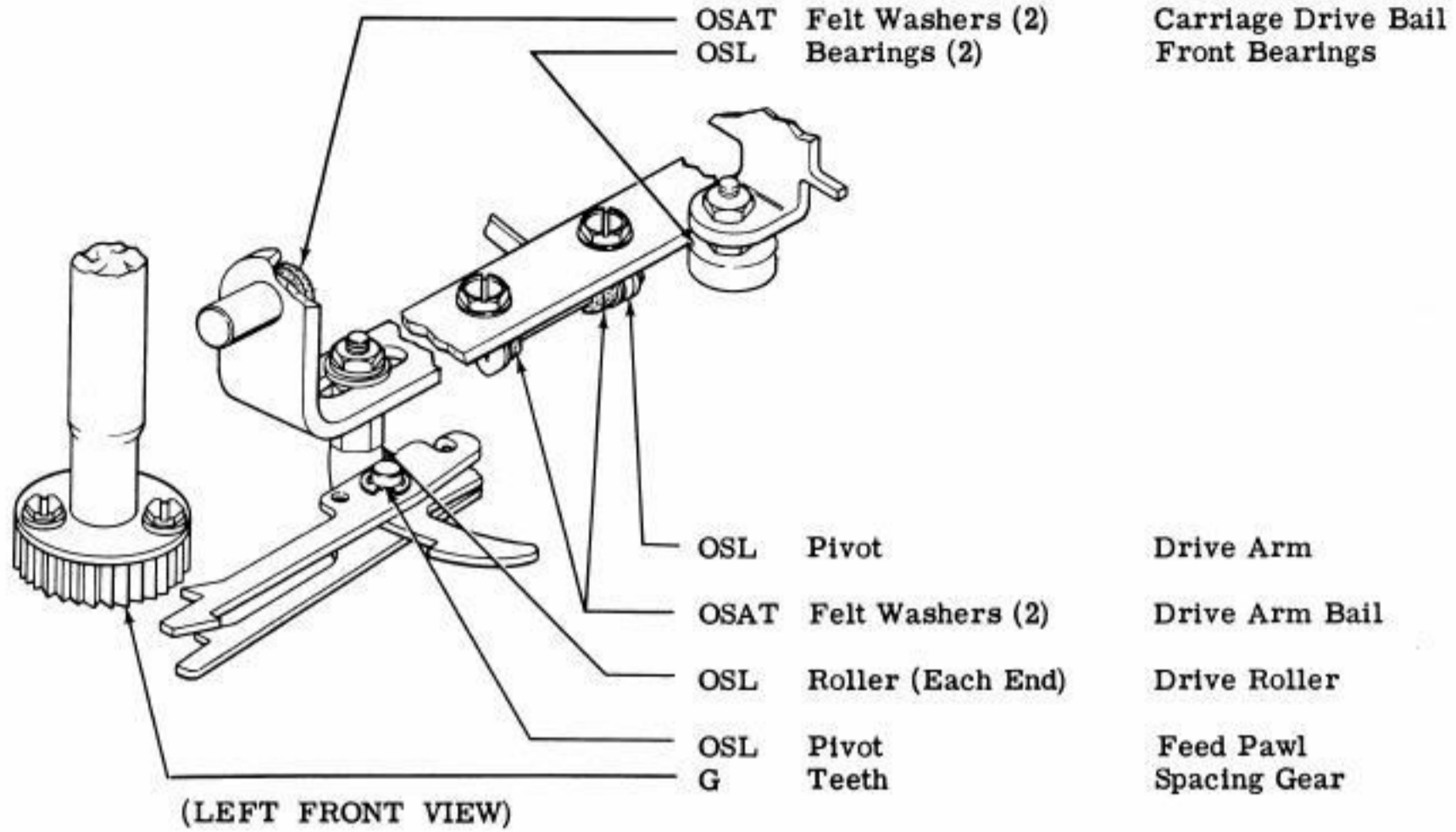

2.28 Spacing Mechanism - 2

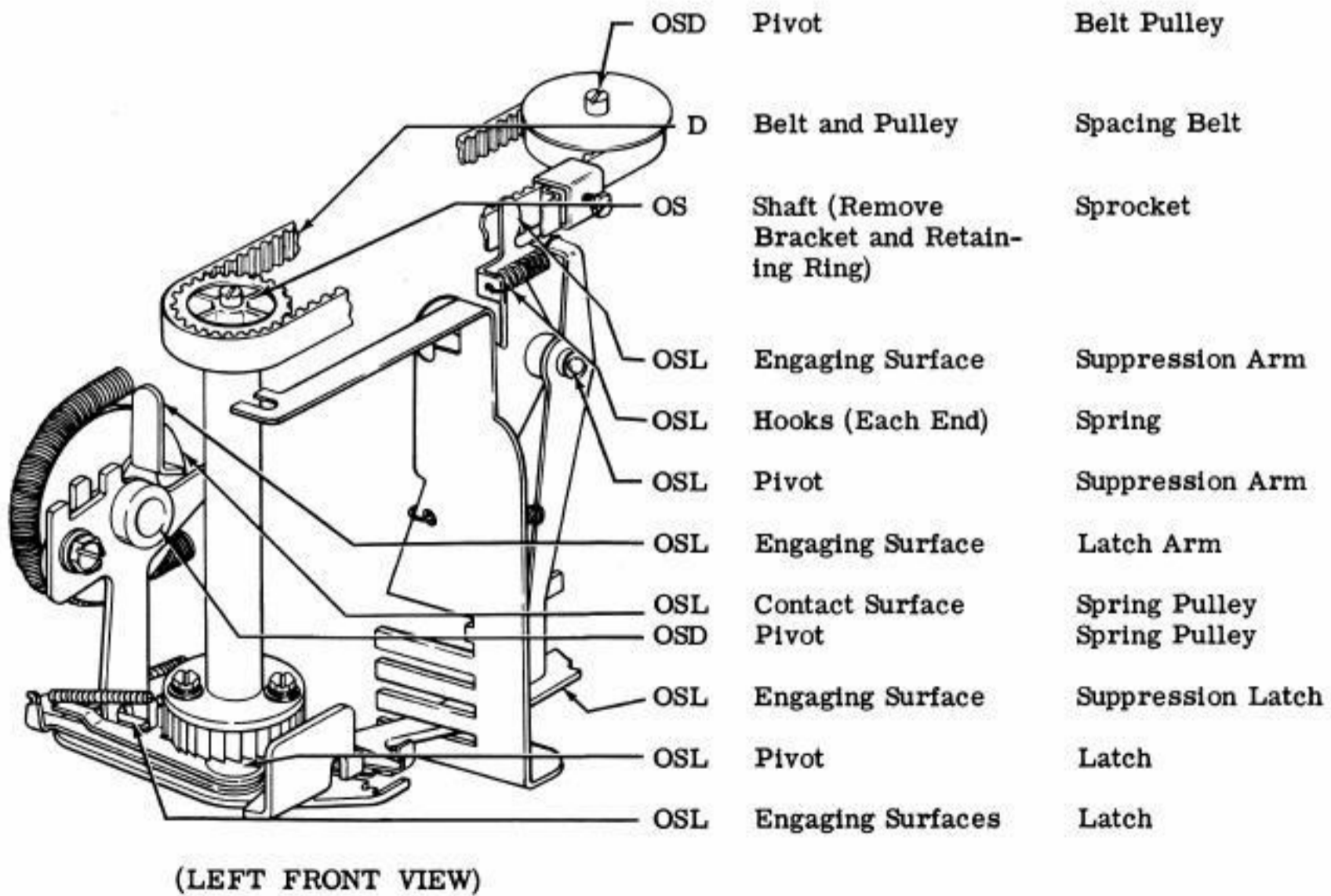

2.29 Carriage Area

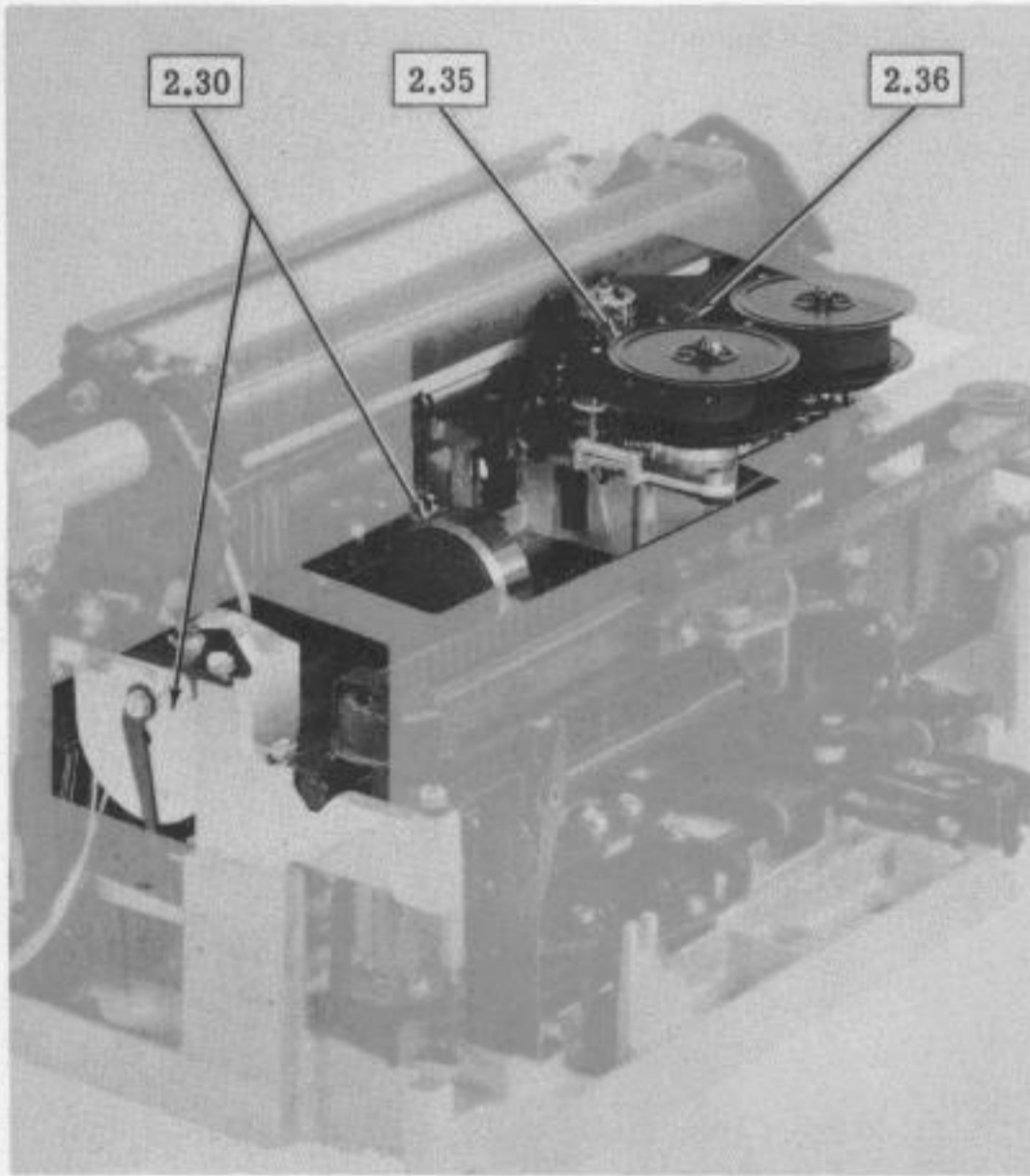

(LEFT FRONT VIEW)

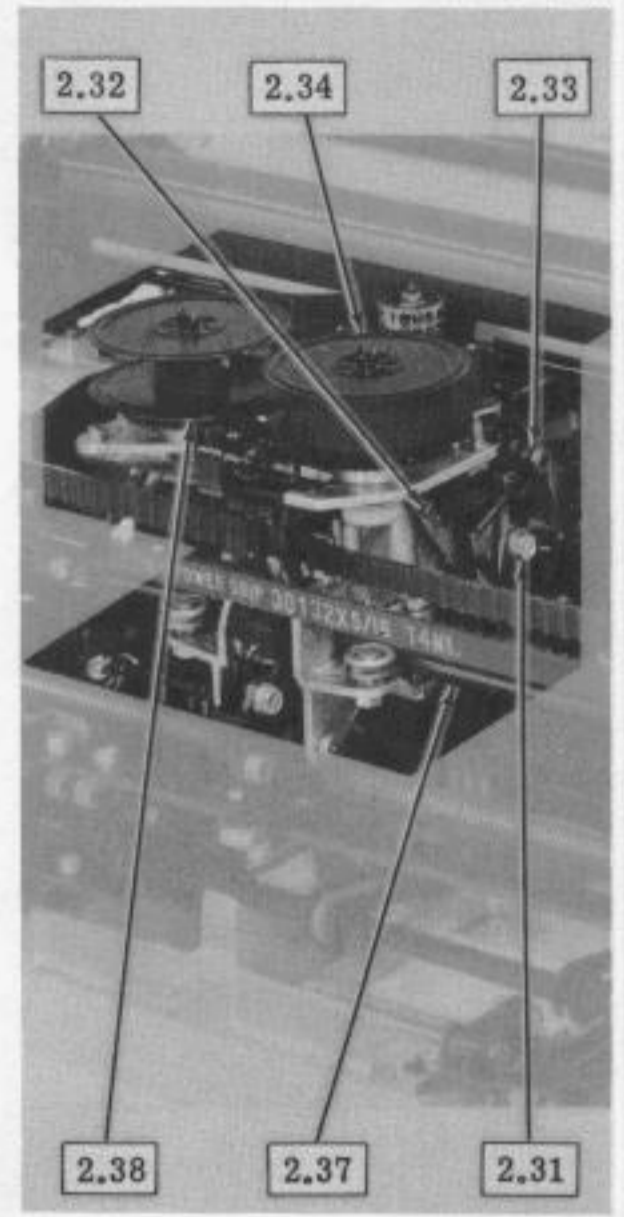

(RIGHT FRONT VIEW)

Note: Remove ribbon mechanism before lubricating. For instructions, see the appropriate typing unit section.

2.30 Dashpot

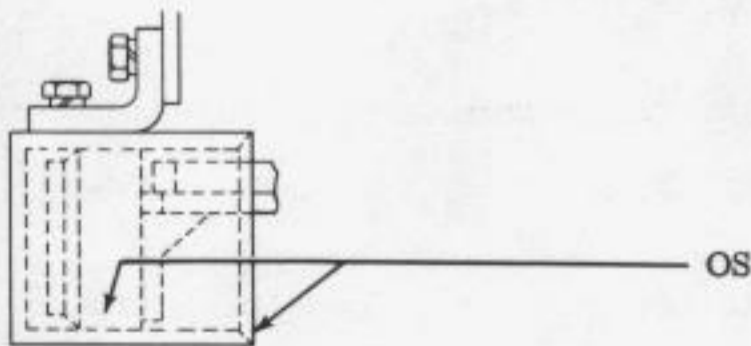

Sliding Surfaces      Dashpot and Cylinder  
 (Apply with oil dampened cloth. Too much lubricant will cause malfunction.)

(FRONT VIEW)

2.31 Print Hammer

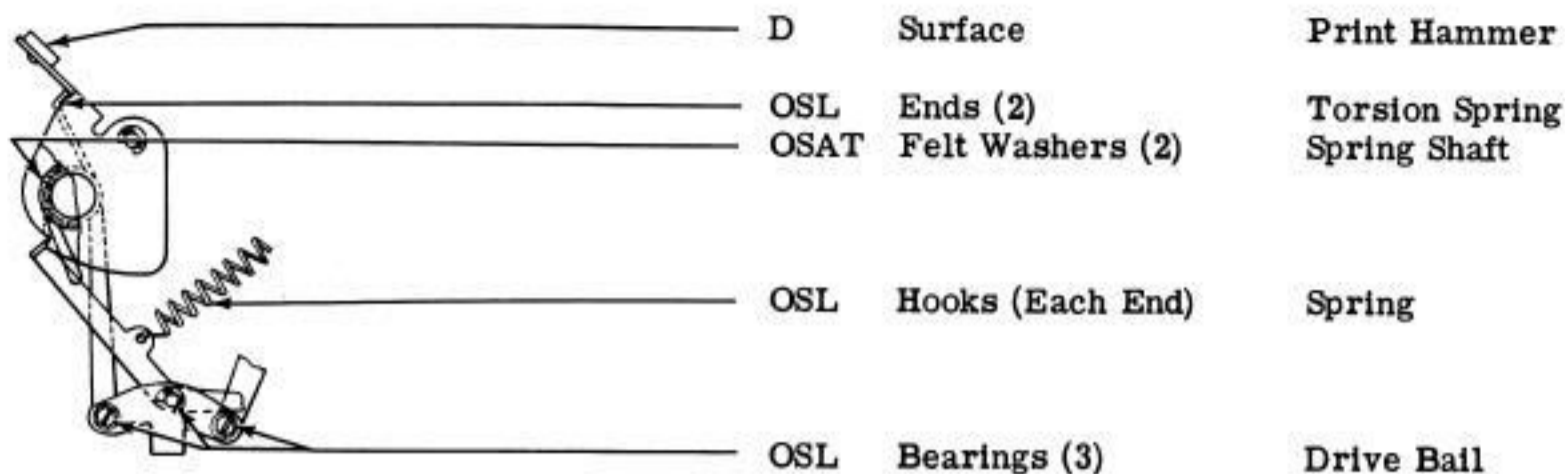

(RIGHT SIDE VIEW)

2.32 Reset Arm

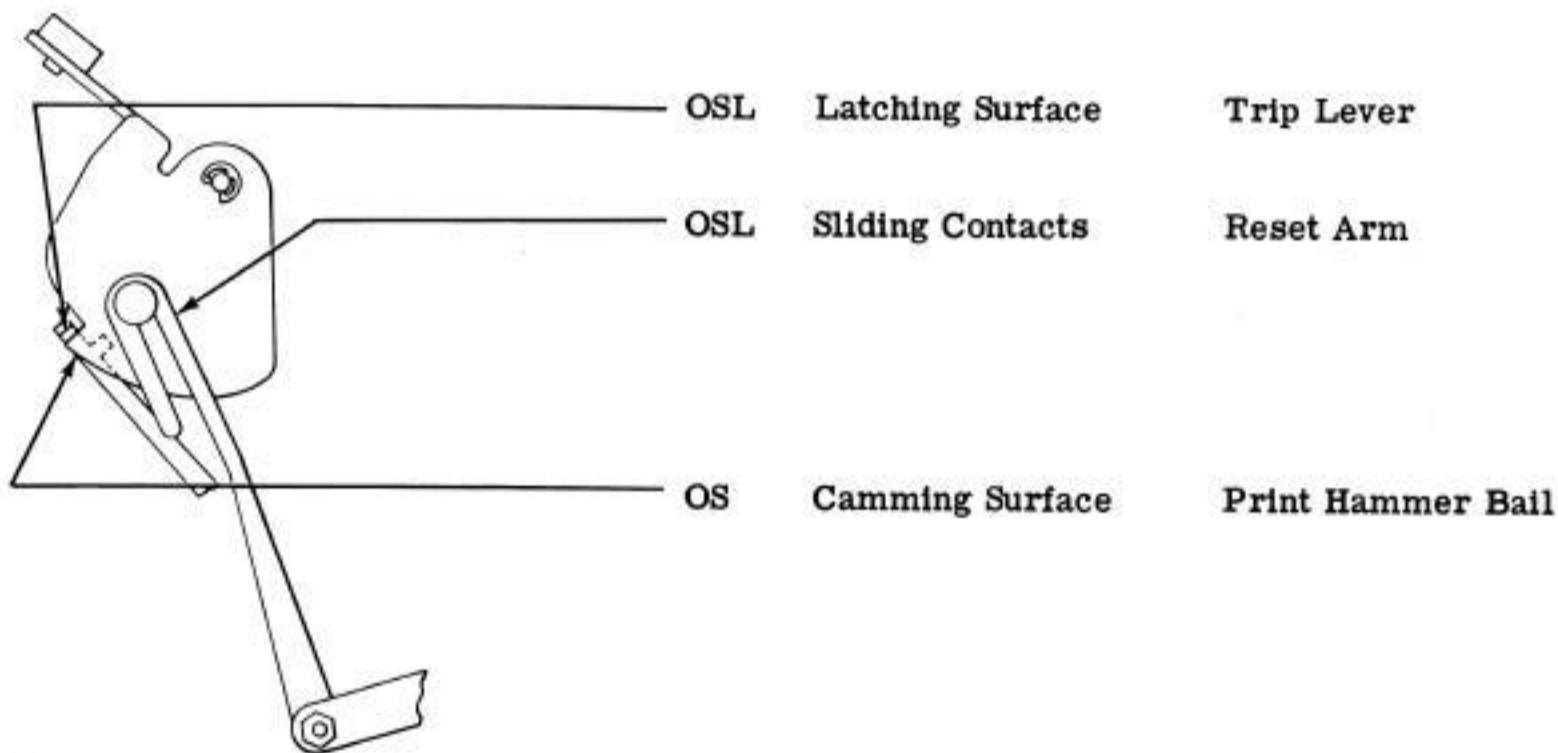

(RIGHT SIDE VIEW)

2.33 Slide Guide Plates - 1

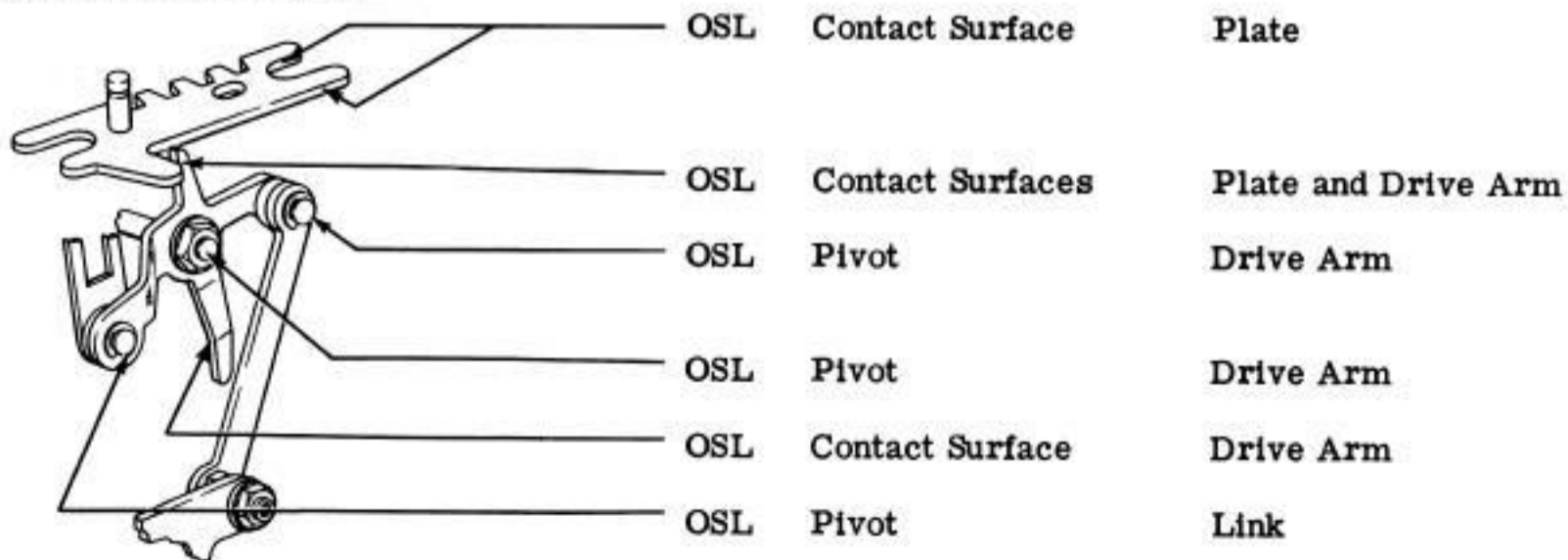

(RIGHT SIDE VIEW)

2.34 Slide Guide Plates - 2

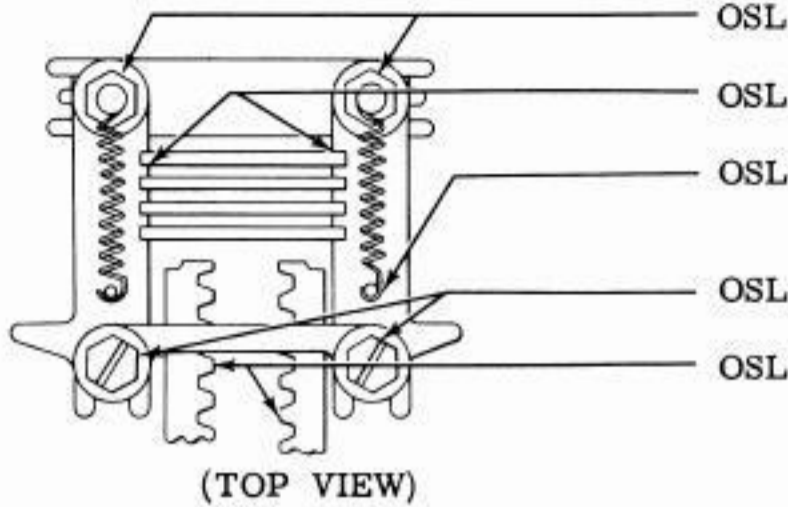

- OSL Sliding Contacts Stop Plate
- OSL Engaging Surfaces Stop Slides (4)
- OSL Hooks (Each End) Springs (2)
- OSL Contact Points Slide Guides (2)
- OSL Teeth Pinion Racks (2)

2.35 Ribbon Guide Spring

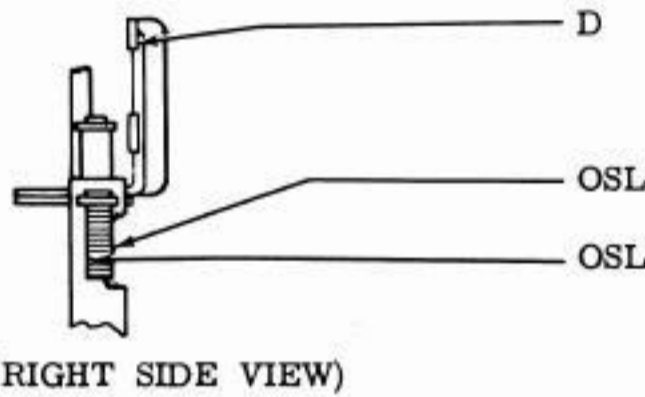

- D Surfaces in Contact With Ribbon Ribbon Guide
- OSL Seat (Each End) Springs (2)
- OSL Sliding Contacts Lifter Arm

2.36 Typewheel Mechanism

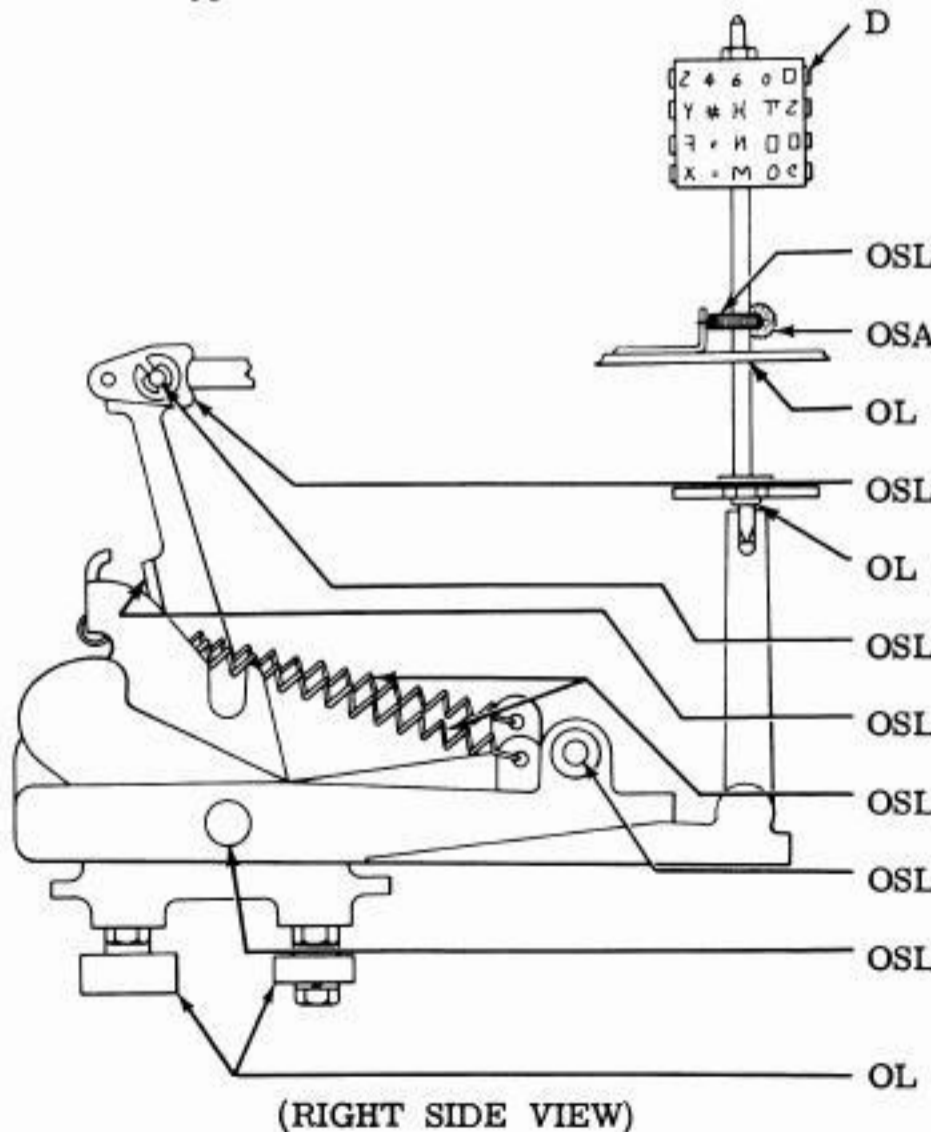

- D Printing Surface Typewheel
- OSL Hooks (Each End) Return Spring
- OSAT Felt Wick Typewheel Shaft
- OL Upper Bearing Positioning Cage
- OSL Engaging Surfaces (2) Rotary Drive Lever
- OL Lower Bearing Positioning Cage
- OSL Pivot Pulse Link
- OSL Contact Surface Power Bail
- OSL Hooks (Each End) Springs (2)
- OSL Pivot Drive Arm
- OSL Pivot Power Bail
- OL Bearings Rollers (Front and Rear - 2 Each)

2.37 Slides

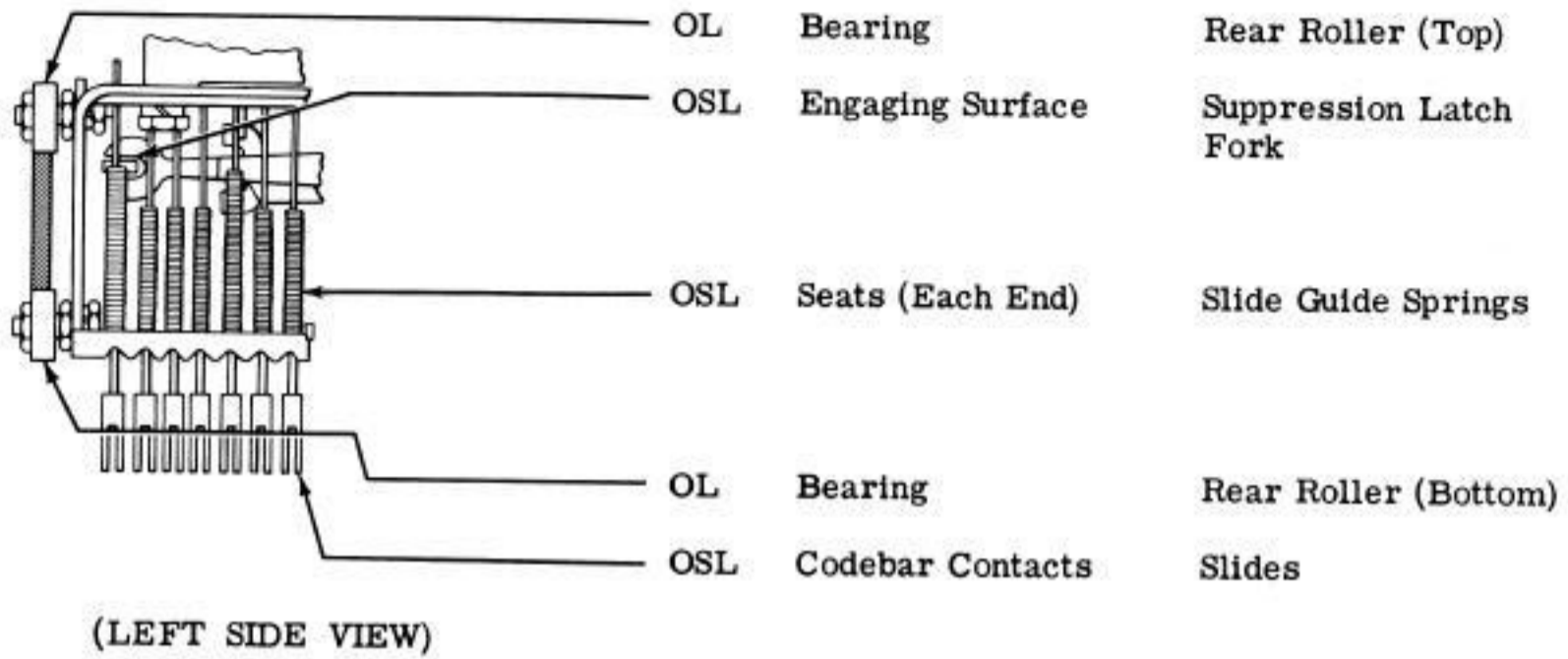

2.38 Ribbon Mechanism

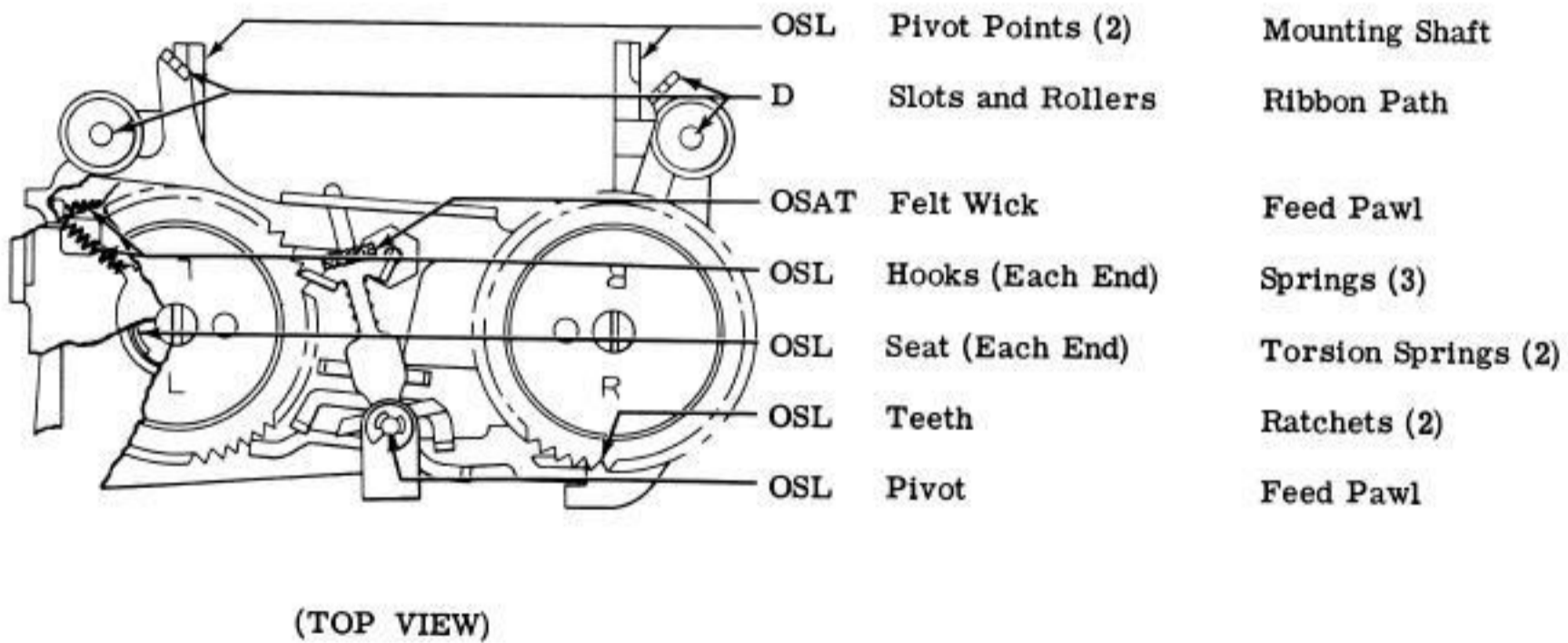



2.39 Motor Area

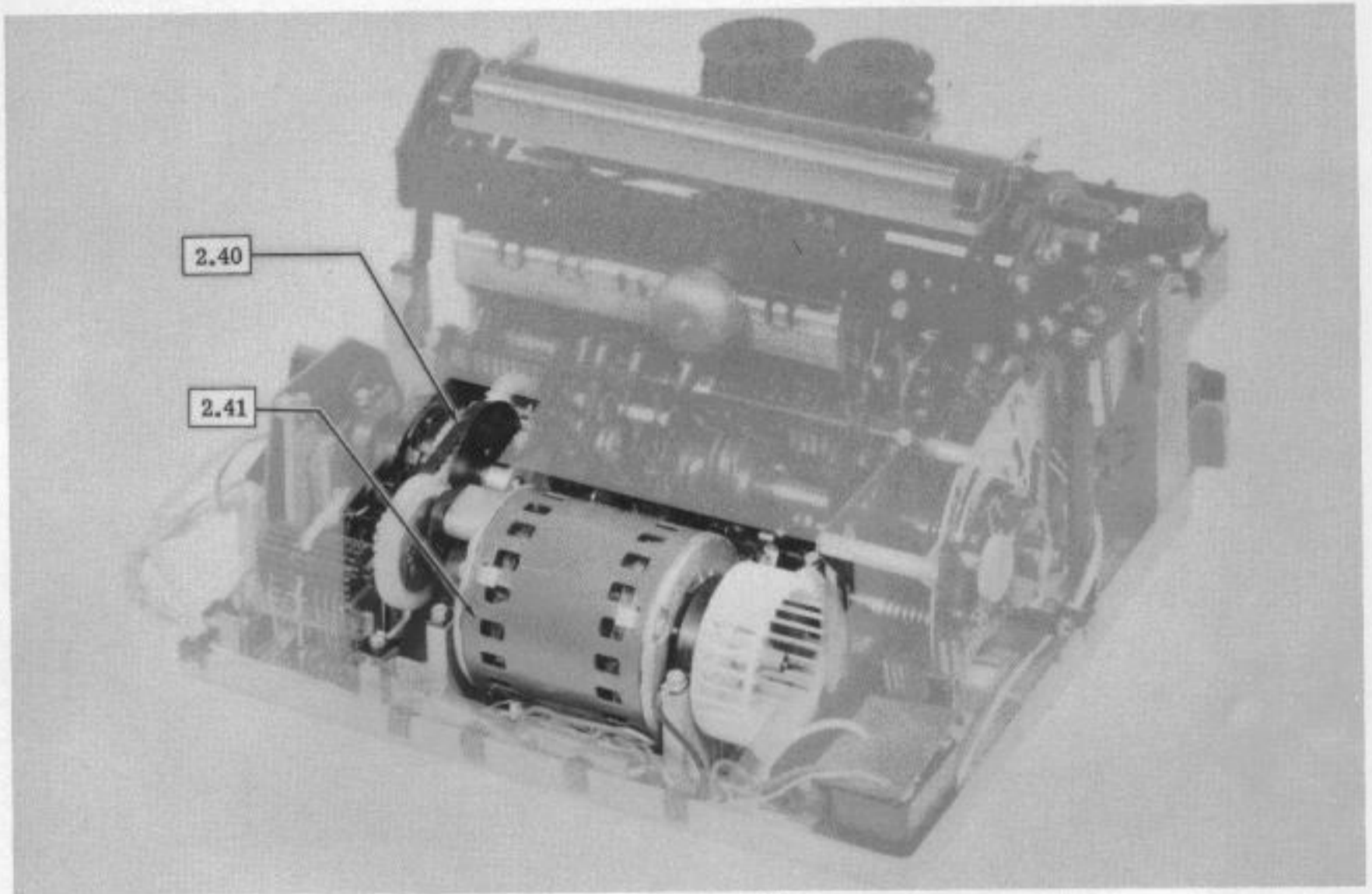

(REAR VIEW)

2.40 Intermediate Gears

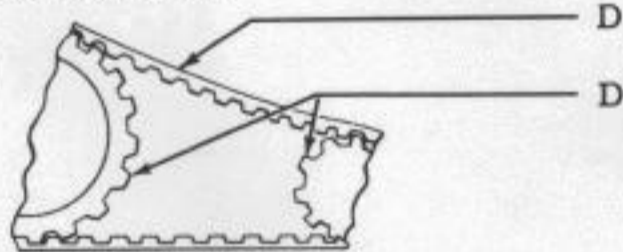

(RIGHT SIDE VIEW)

D Motor Belt

D Teeth

Sprockets (2)

2.41 Motor

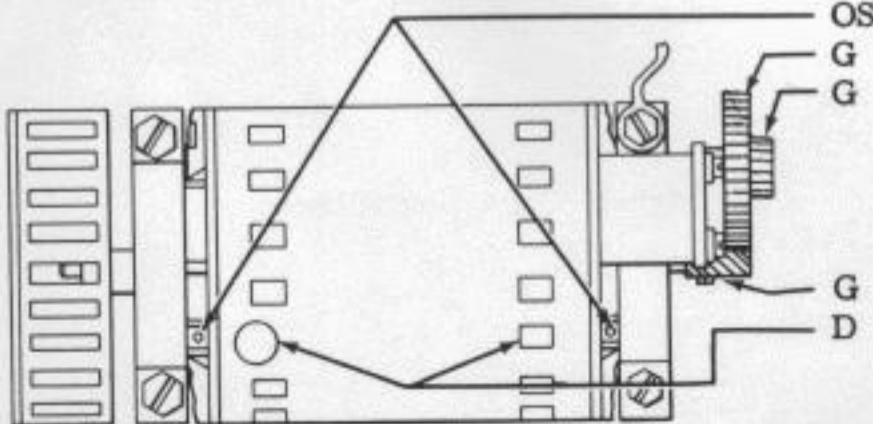

(TOP VIEW)

OS Bearings (Each End)  
G Teeth

Pack Grease in Space Between Two Oilite Bearings. Intermediate Gear Must Be Removed.

G Teeth  
D Interior Areas

Motor Shaft  
Intermediate Gear  
Intermediate Gear

Motor Pinion  
Motor

**CAUTION:** MOTOR START RELAY AND CAPACITOR MUST BE KEPT FREE OF LUBRICANTS.

FRICION FEED MECHANISMS

2.42 Paper Feed Area

Note: Reinstall ribbon mechanism. For instructions, see the appropriate typing unit section.

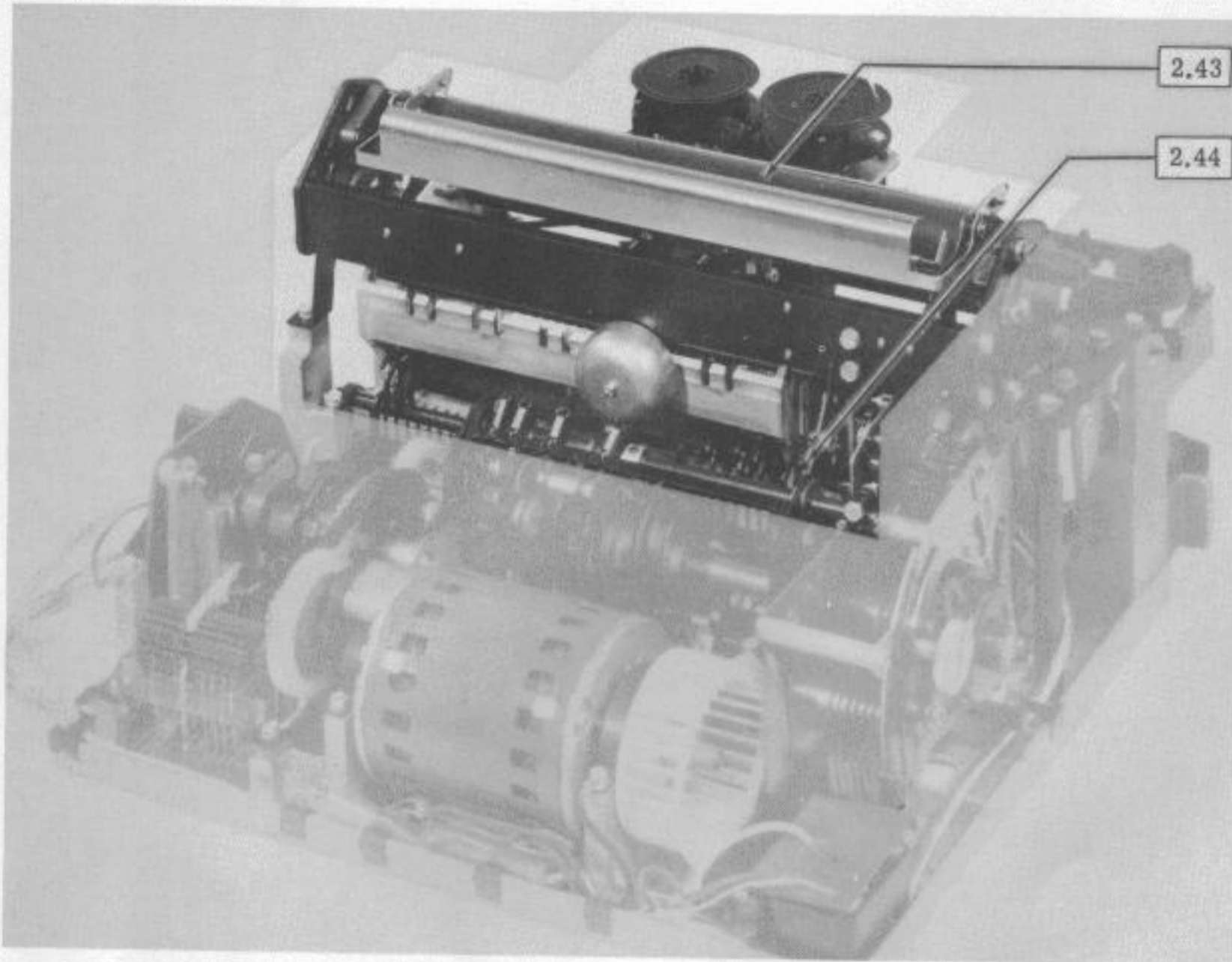

(REAR VIEW)

2.43 Platen

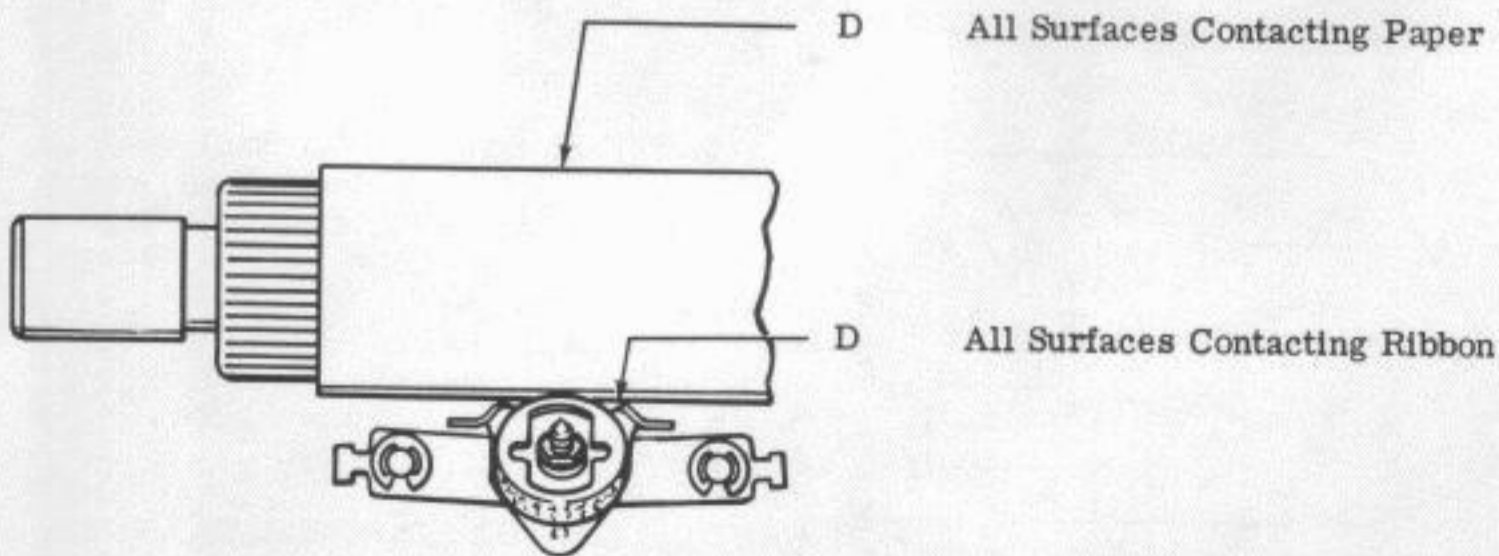

CAUTION: DO NOT CLEAN PLATEN WITH SOLVENTS.

2.44 Line Feed Mechanism

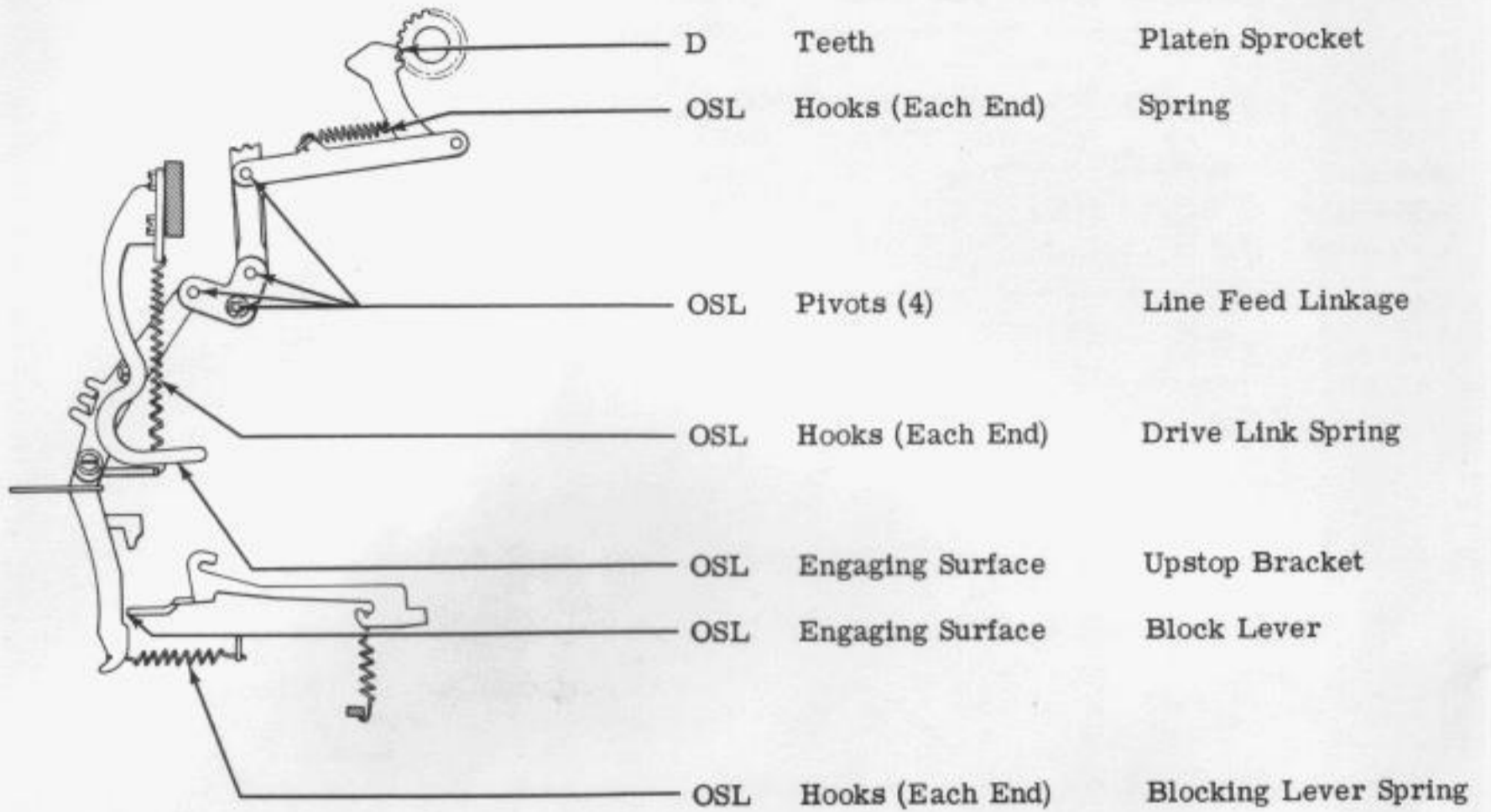

(LEFT SIDE VIEW)

SPROCKET FEED MECHANISMS

2.45 Paper Feed Area

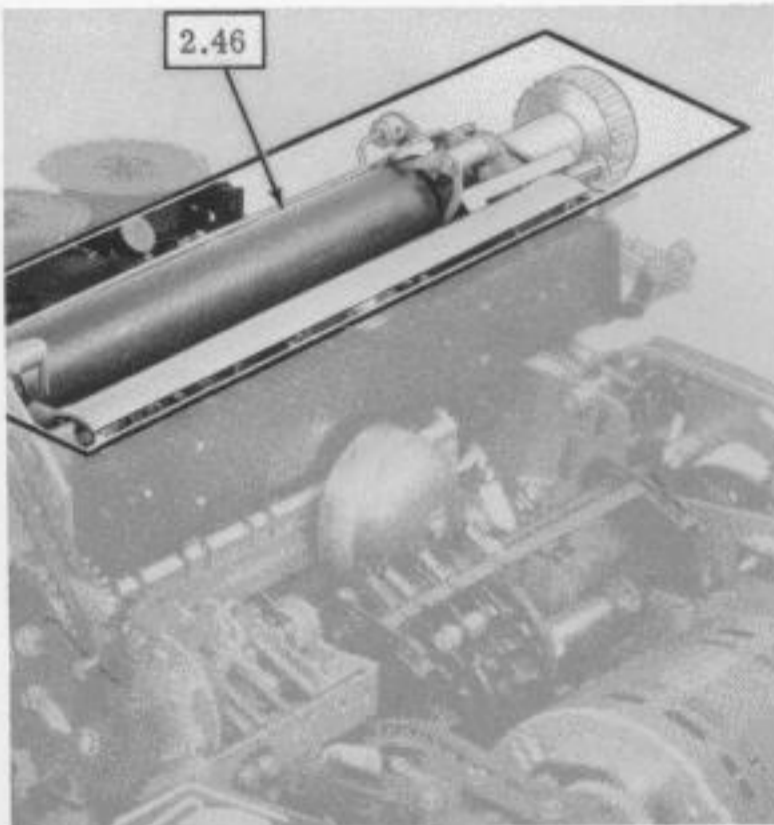

(RIGHT REAR VIEW)

Note: Reinstall ribbon mechanism. For instructions, see the appropriate typing unit section.

2.46 Platen Mechanism

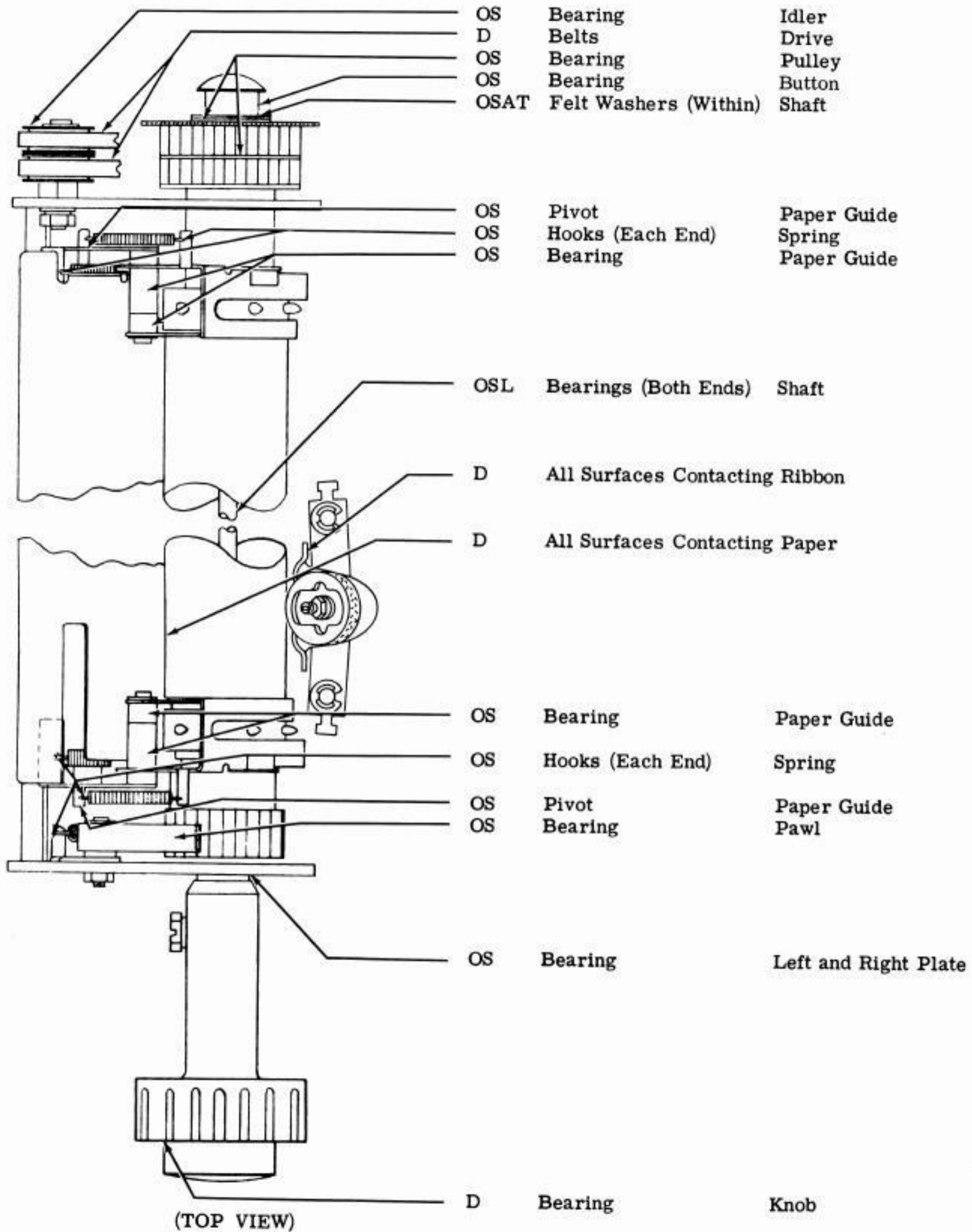

2.47 Platen Drive Area

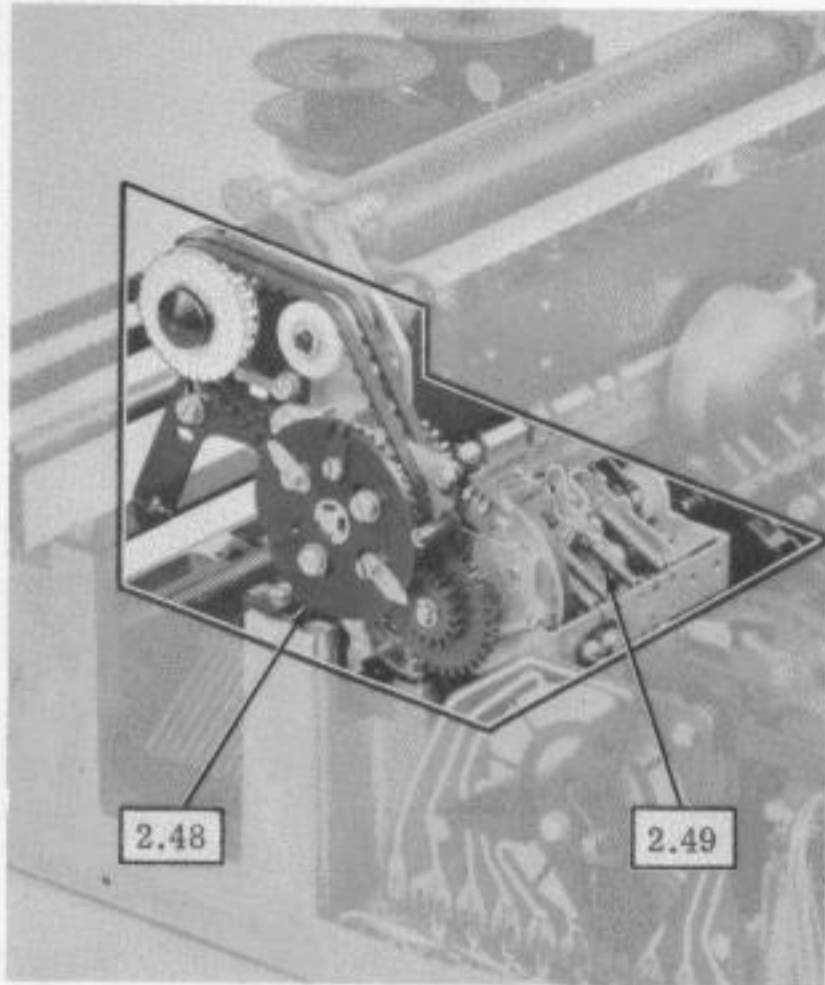

(RIGHT REAR VIEW)

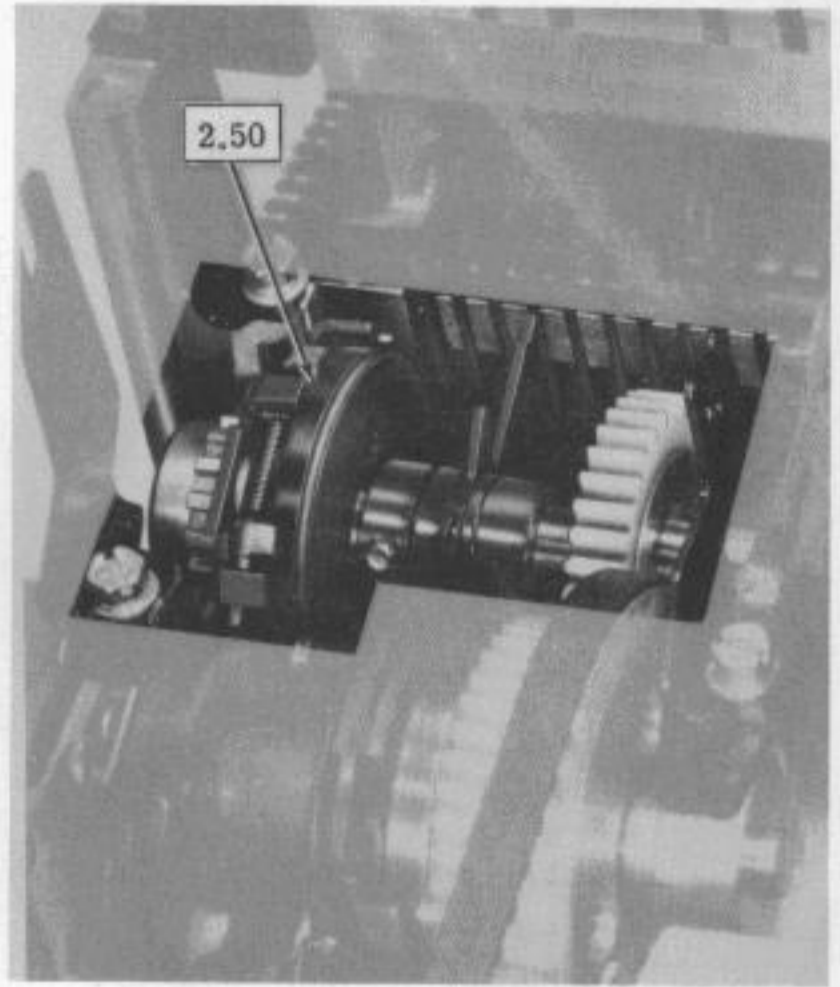

(LEFT REAR VIEW)

(Form-out mechanism removed for illustration purposes. Removal for lubrication is not required.)

2.48 Cam, Pulley, and Gear Combination

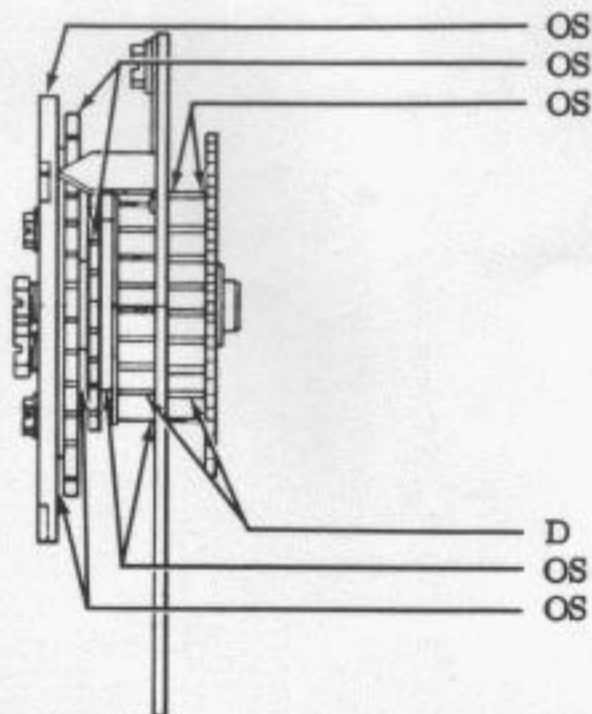

(TOP VIEW)

OS Cam Surface  
OS Gear Surface  
OS Bearing

Cam Gear  
Cam Gear  
Gear and Pulley

D Surface  
OS Bearing  
OS Bearing

Pulley  
Gear and Pulley  
Cam Gear

2.49 Form-Out Mechanism

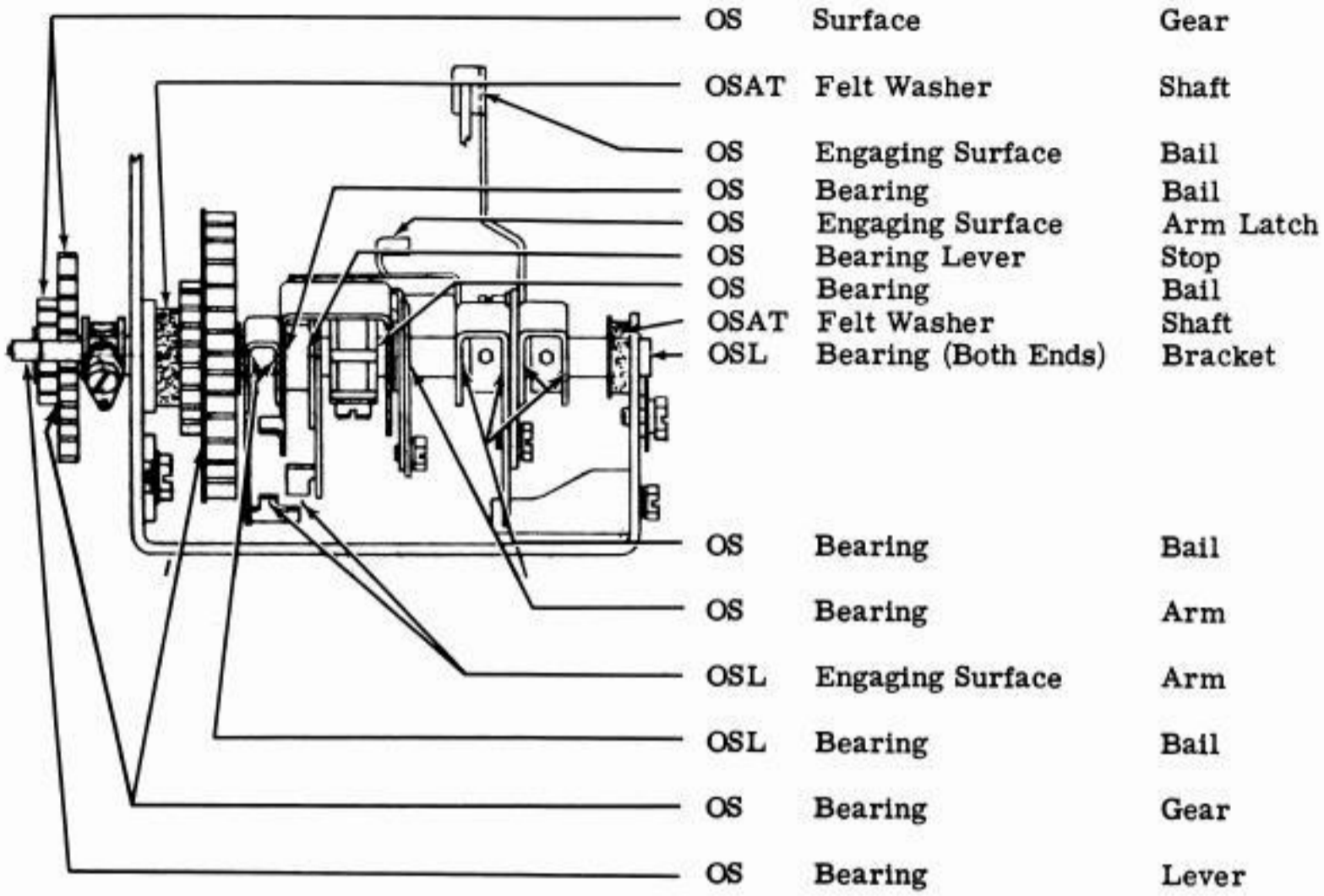

(TOP VIEW)

2.50 Line Feed Clutch

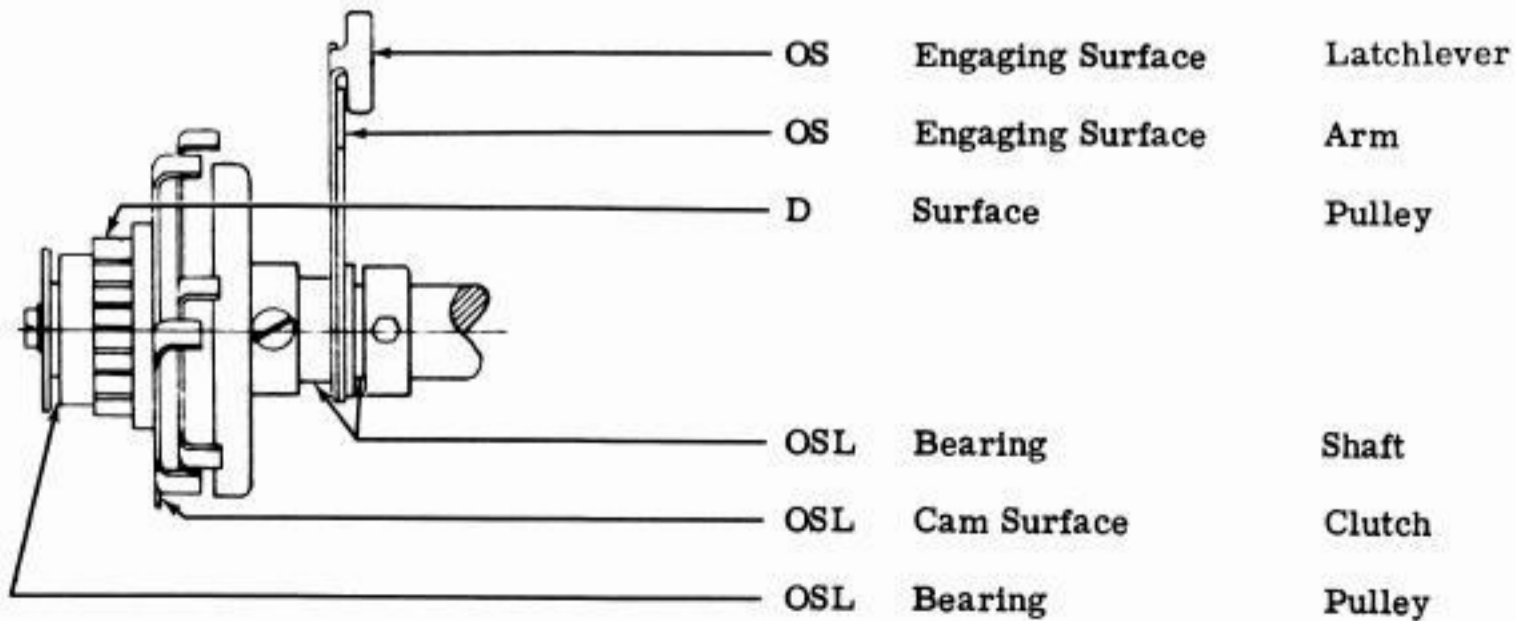

(TOP VIEW)

3. VARIATIONS TO BASIC UNITS

3.01 Answer-Back Area

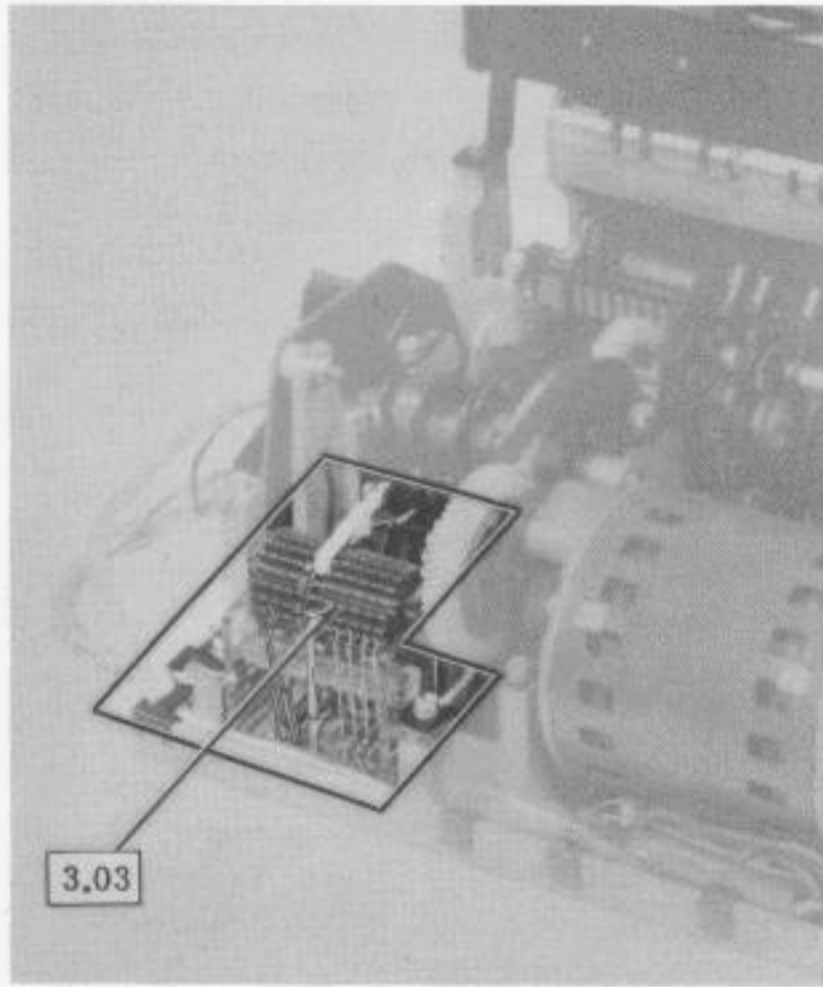

(LEFT REAR VIEW)

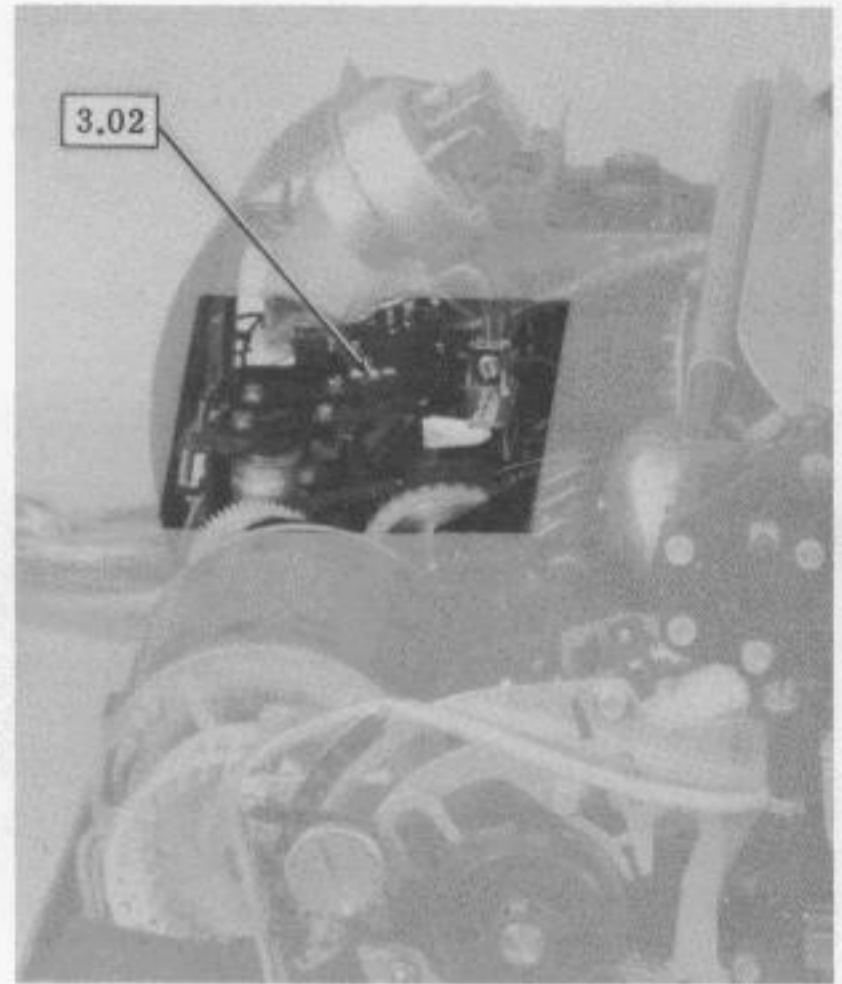

(LEFT SIDE VIEW)

3.02 Trip Magnet

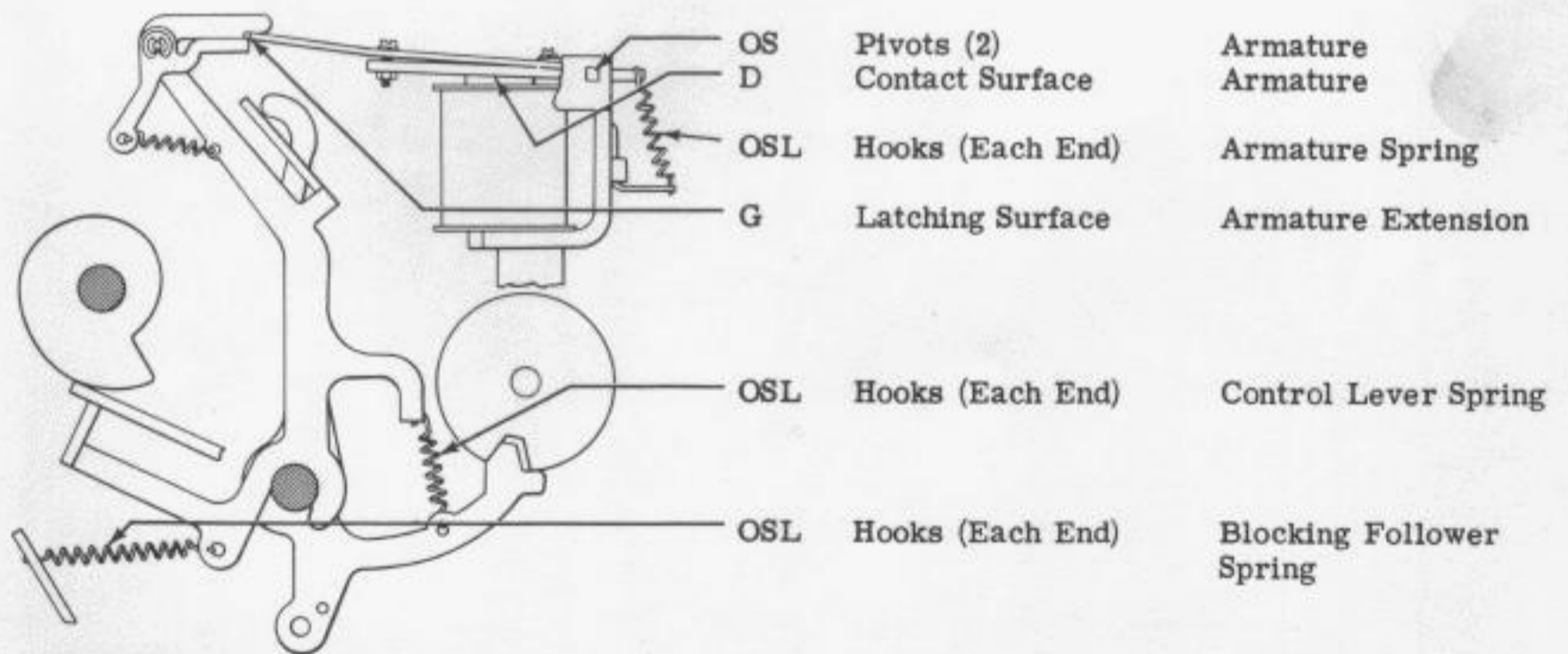

3.03 Answer-Back Mechanism

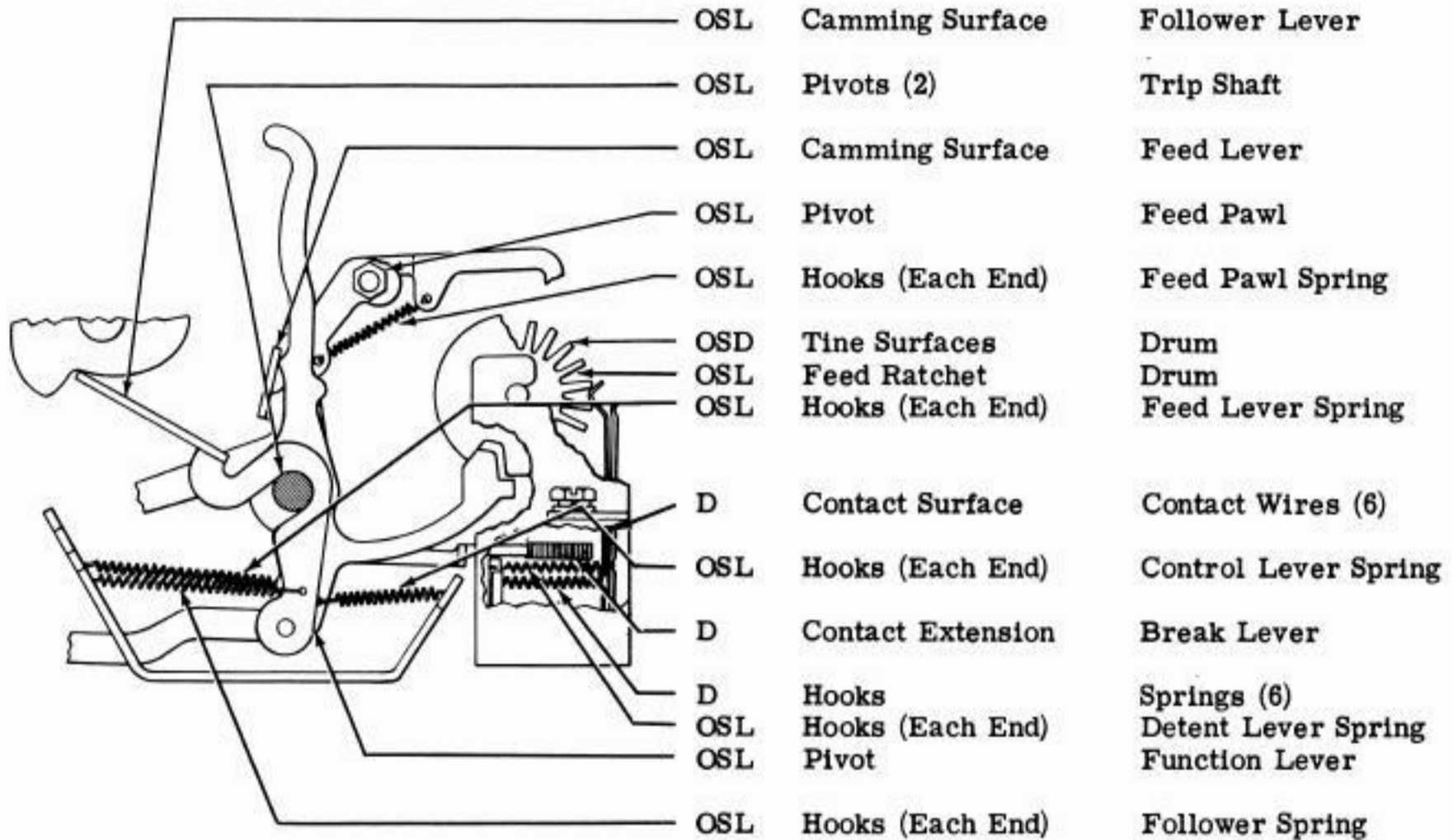

CAUTION: DO NOT CLEAN CONTACT BLOCK WITH SOLVENTS.