

EPK - 2/12/45

FOR GENERAL DISTRIBUTION
TO BELL SYSTEM

BULLETIN No. 1074

ISSUE 2

JANUARY, 1945

TELETYPE

PRINTING TELEGRAPH SYSTEMS

PARTS

TYPE WHEEL PAGE PRINTER

(MODEL 26)

TELETYPE

INC. U.S. PAT. OFF.

CORPORATION

SUBSIDIARY OF

Western Electric Company

CHICAGO, U.S.A.

TELETYPE

PRINTING TELEGRAPH SYSTEMS

PARTS

TYPE WHEEL PAGE PRINTER

(MODEL 26)

BELL SYSTEM NOTE:

When ordering parts from this Bulletin, each number should be followed by the letter M. without parentheses, in order to identify the item as one to be secured from the Teletype Corporation.



REG. U.S. PAT. OFF.
CORPORATION

SUBSIDIARY OF
Western Electric Company

CHICAGO, U. S. A.

ALPHABETICAL INDEX

DESCRIPTION	PAGE NO.	DESCRIPTION	PAGE NO.
Arm - Function - - - - -	3, 5 & 6	Keyboard (Assem.) - Top View - - - - -	13
Arm - Stop (Assem.) - - - - -	3	Keyboard (Assem.) - Bottom View - - - - -	14
Bail - Printing (Assem.) - - - - -	7	Keyboard Shaft (Assem.) - - - - -	15
Base Plates - - - - -	14,16,17	Keytops - - - - -	28
Base - Keyboard - - - - -	13,14	Line Cord - - - - -	18
Base - Receiving - - - - -	16	Line Guide - Message - - - - -	27
Bracket (Assem.) - D.C. Motor - - - - -	25	Line Relay Mounting (Assem.) - - - - -	18
Bracket - Front (Assem.) - - - - -	4	Main Frame (Assem.) - - - - -	2
Bracket Parts - Paper - - - - -	11,12	Message Line Guide - - - - -	27
Buffer Cylinder - - - - -	1	Motors - - - - -	22,23,24
Cables - - - - -	2,13,16,18	Motor Bracket (Assem.) - D.C. - - - - -	25
Cam Sleeve (Assem.) - - - - -	4,8,15	Motor Units (Assem.) - - - - -	22,23,30
Carriage (Assem.) - - - - -	10	Name Plate - - - - -	4
Carrying Handle - Set of Parts - - - - -	17	Notes of Explanation - - - - -	32
Chute - Paper (Assem.) - - - - -	11,12	Numerical Index - - - - -	33
Clutch - Overriding - - - - -	8	Overriding Clutch - - - - -	8
Clip - Paper (Assem.) - - - - -	27	Pallets - - - - -	28
Code Discs - - - - -	3	Paper Bracket Parts - - - - -	11,12
Condensers - - - - -	13,18,25	Paper Chute (Assem.) - - - - -	11,12
Contacts (Assem.) - - - - -	15,20,21	Paper Clip (Assem.) - - - - -	27
Control Relay (Assem.) - - - - -	18,19	Paper Roll Holder - Small - - - - -	11
Copy Holder - - - - -	27	Paper Roll Spindle - - - - -	11,12
Cords - Power and Line - - - - -	18,19	Plate - Function (Assem.) - - - - -	9
Cover (Assem.) - - - - -	27	Plate - Name - - - - -	4
D.C. Motor Bracket (Assem.) - - - - -	25	Platen Roll (Assem.) - - - - -	10
Discs - Code - - - - -	3	Power Cord - - - - -	18
Draw Strap - - - - -	1	Power Switch - Set of Parts - - - - -	13,16
Drum Spring (Assem.) - - - - -	1	Printing Bail (Assem.) - - - - -	7
Filter (Assem.) - - - - -	26	Pulsing Contact (Assem.) - - - - -	21
Frame - Main (Assem.) - - - - -	1	Range Finder (Assem.) - - - - -	8
Frame - Rear (Assem.) - - - - -	1	Rear Frame (Assem.) - - - - -	1
Front Bracket (Assem.) - - - - -	4	Receiving Base - - - - -	16
Function Arm - - - - -	3,5,6	Relay Mounting - Line (Assem.) - - - - -	18
Function Plate (Assem.) - - - - -	9	Relay - Control (Assem.) - - - - -	18
Gear - - - - -	3,4,8,13,15,22,23	Remote Signal Bell Contact (Assem.) - - - - -	20
Governor Parts - - - - -	25	Resistors - - - - -	3,13,17,18,19
Handle - Carrying - Set of Parts - - - - -	17	Ribbon Feed Mechanism (Assem.) - - - - -	7
Holder - Paper Roll - Small - - - - -	11,12	Selector Drum (Assem.) - - - - -	3
Index - Numerical - - - - -	33	Selector Shaft (Assem.) - - - - -	8

DESCRIPTION	PAGE NO.
Selector Unit (Assem.) - - - - -	8
Set of Carrying Handle Parts - - - - -	17
Set of Paper Bracket Parts - - - - -	11,12
Set of Paper Bracket Parts (For 8½" Paper)	11,12
Set of Parts for Break Lock Mechanism - - - -	20
Set of Parts for Offset Copyholder - - - - -	27
Set of Stop Contact Parts - - - - -	20
Set of Parts for Converting a 26-A and 26-C Typing Unit to a 26-B and 26-D Typing Unit (Bell System) - - - - -	29
Set of Parts for Converting a 26-B and 26-D Typing Unit to a 26-A and 26-C Typing Unit (Bell System) - - - - -	29
Set of Parts to Equip a Keyboard Base with "Upper Case "H" Motor Control" - - - - -	29
Set of Parts to Equip a Typing Unit with "Upper Case "H" Motor Control" - - - - -	29
Set of Parts to Apply Signal Distortion Prevention Detent to Keyboards above 240 o.p.m. - - - - -	29
Set of Parts for .000 -.020 amp. operation -	29
Set of Parts to Provide Improved Lubrication of 26 Printer Type Friction Clutch - - - -	29

DESCRIPTION	PAGE NO.
Set of Parts - Leaf Spring - - - - -	29
Set of Parts - Leaf Spring and Paper Chute (Assem.) - - - - -	29
Set of Power Switch Parts for Send-Receive Base - - - - -	13
Set of Power Switch Parts for Receiving- Only Base - - - - -	16
Shaft - Keyboard (Assem.) - - - - -	15
Shaft - Selector - - - - -	8
Small Paper Roll Holder - - - - -	11,12
Spindle - Paper Roll - - - - -	11,12
Spring Drum (Assem.) - - - - -	1
Stop Arm (Assem.) - - - - -	3
Strap - Draw - - - - -	1
Sub Base Plate (Assem.) - - - - -	17
Switch - Power - Set of Parts - - - - -	13,16
Terminal Block (Assem.) - - - -	13,16,18,19,20
Transmitter (Assem.) - - - - -	15
Type Wheel (Assem.) - - - - -	7
Type Wheel Pallets - - - - -	28

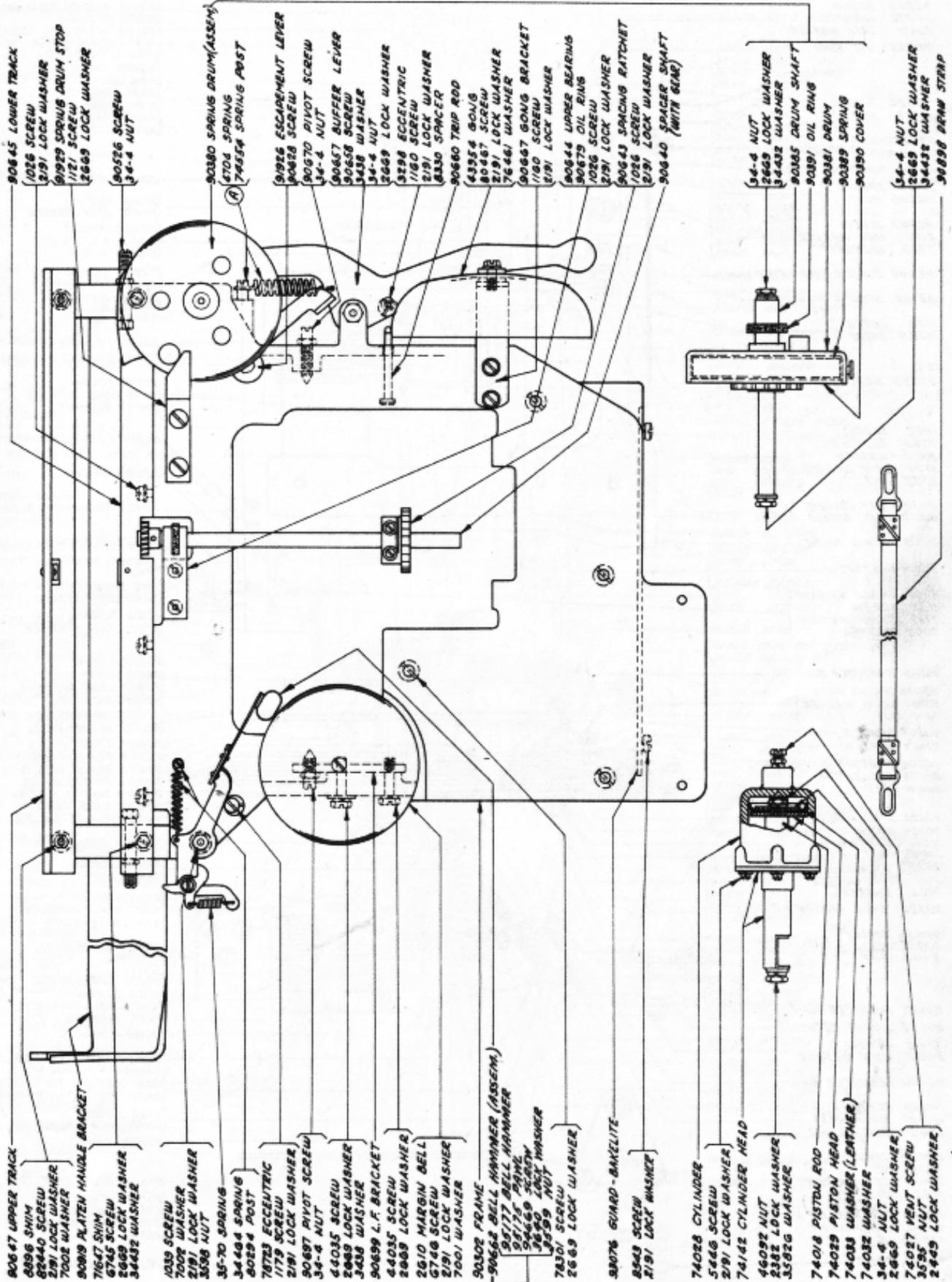

① SEE PAGE 32 FOR EXPLANATION

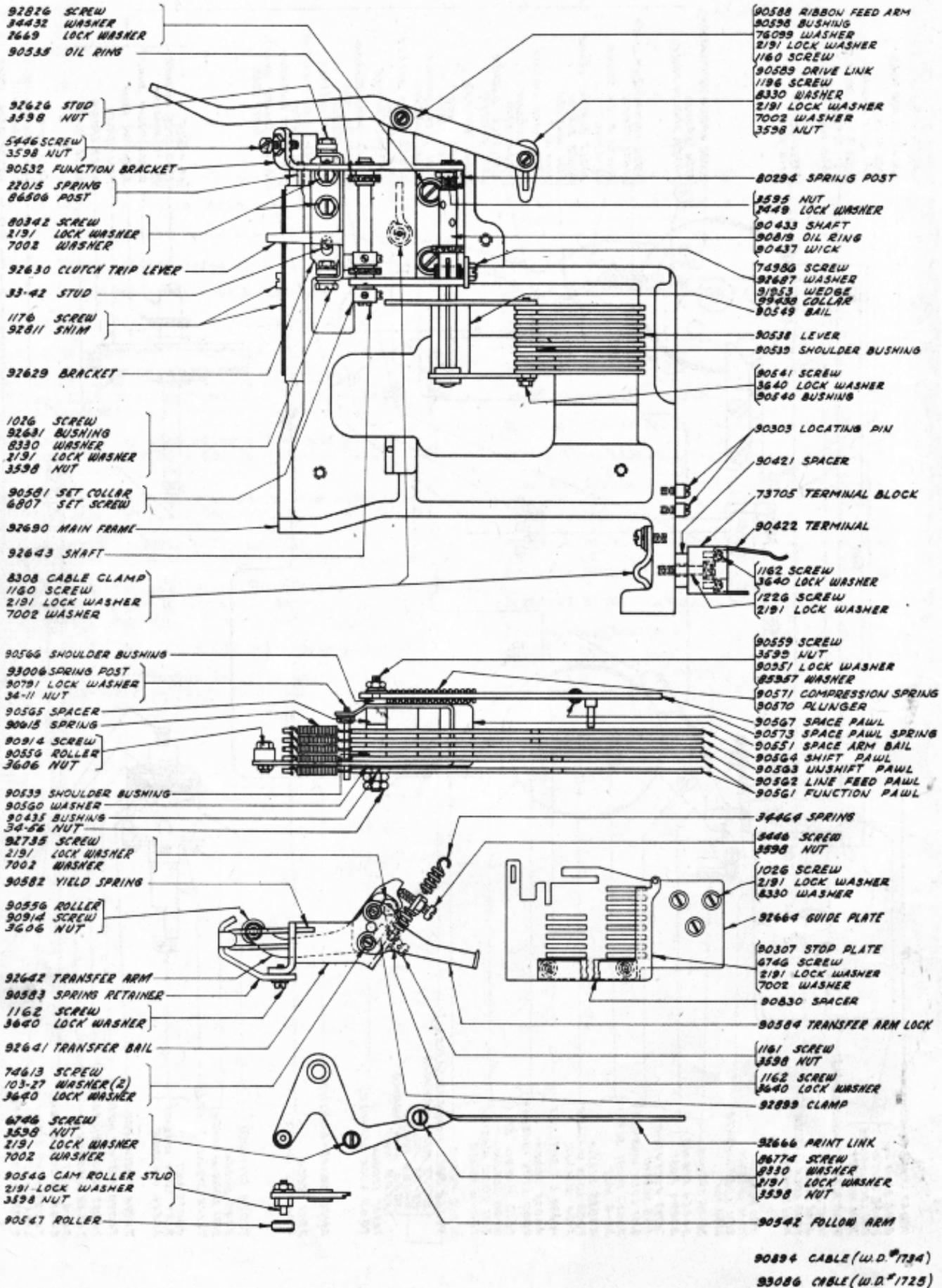

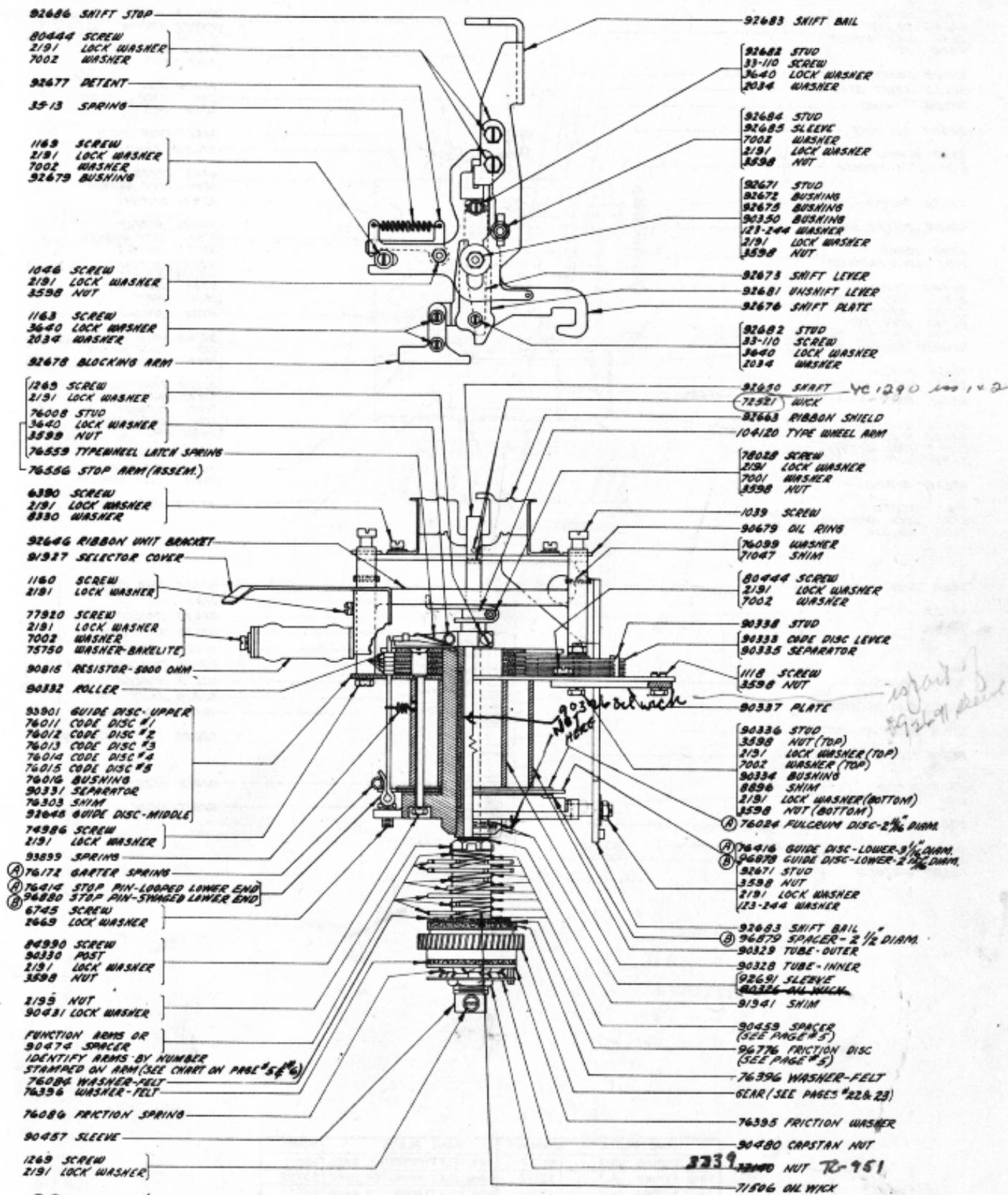

SEE PAGE #3 FOR EXPLANATION

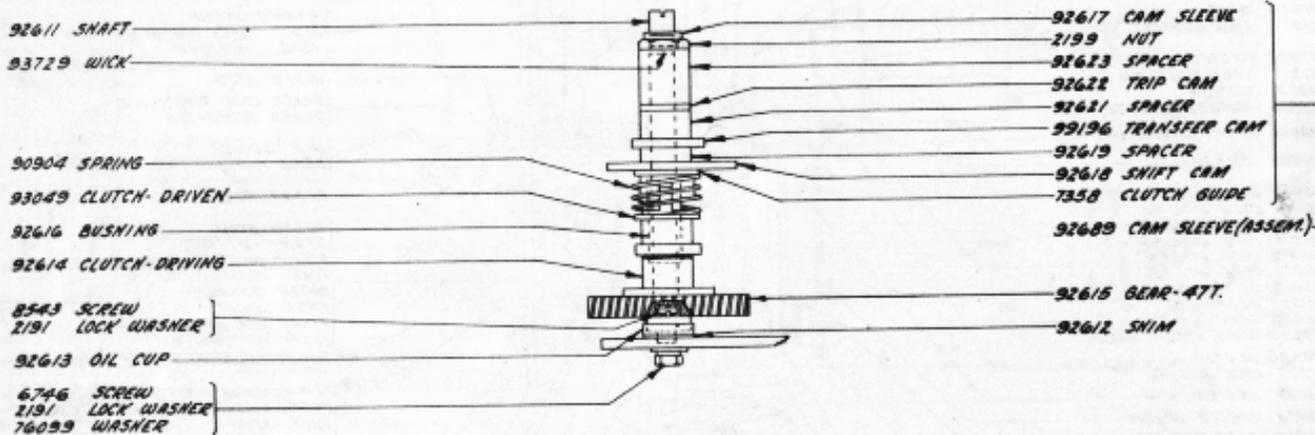
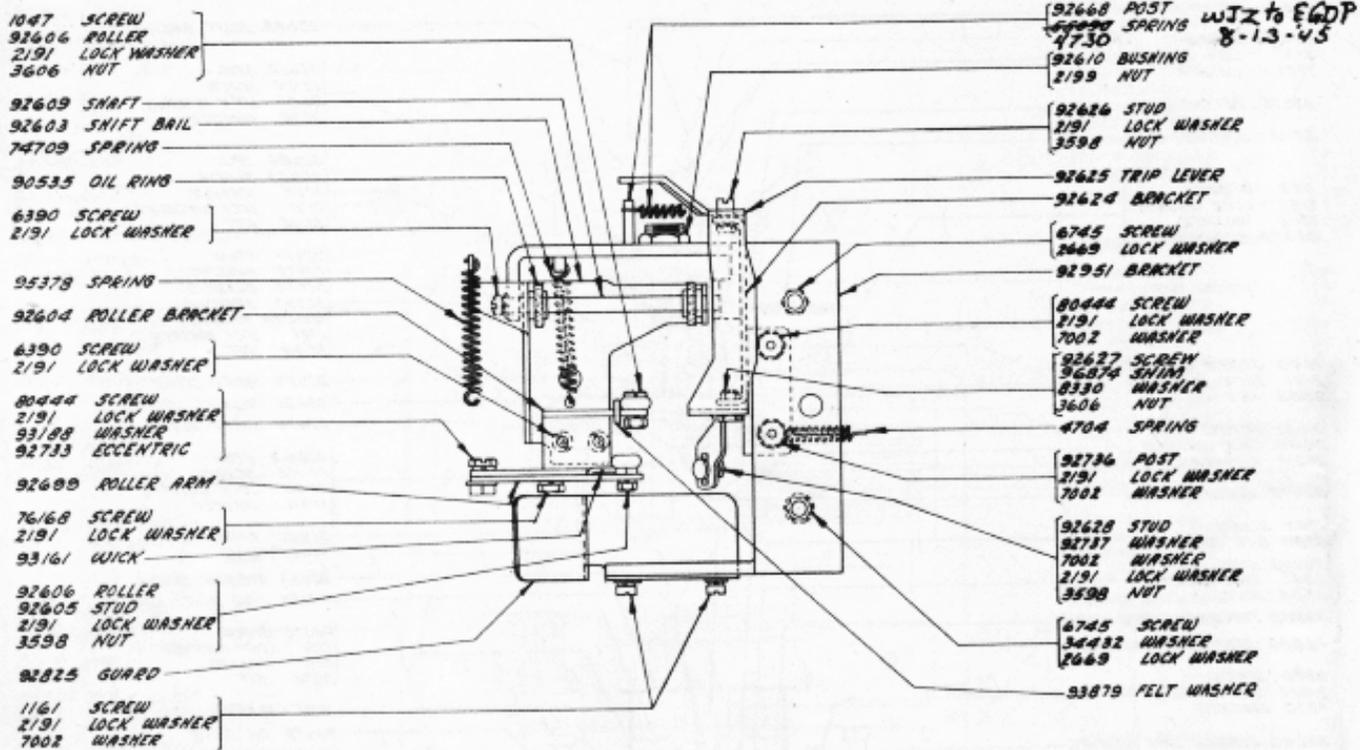

NAME PLATE	NUMBER	NAME PLATE	NUMBER
26-A TYPING UNIT	93747	26-A TELETYPEWRITER BASE	93751
26-B TYPING UNIT	93748	26-B TELETYPEWRITER BASE	93752
26-C TYPING UNIT	93749	26-C TELETYPEWRITER BASE	93753
26-D TYPING UNIT	93750		
26-E TYPING UNIT	96820	(A) TELETYPEWRITER SERVICE	90915
26-F TYPING UNIT	96821	MILL SYSTEM SERVICE (FOR MOTORS)	89946
83408 NAME PLATE MOUNTING SCREW			
91685 NAME PLATE MOUNTING SCREW (FOR 89946 NAME PLATE)			
(A) USED ON COVERS			

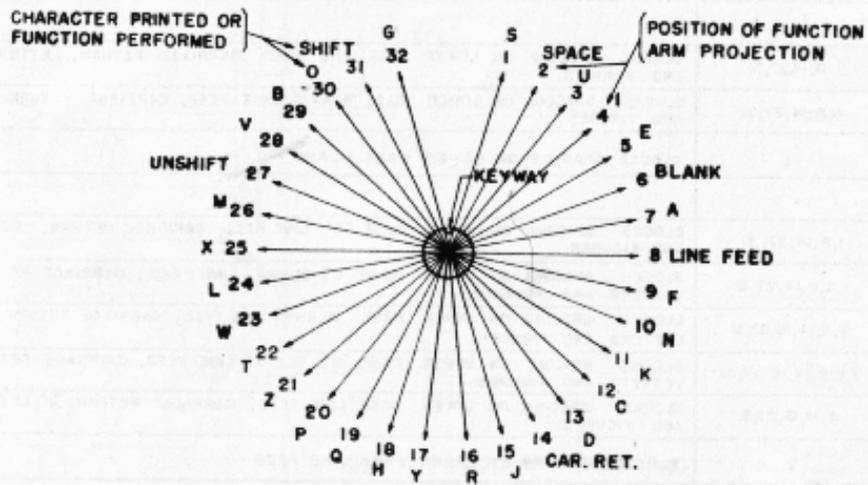
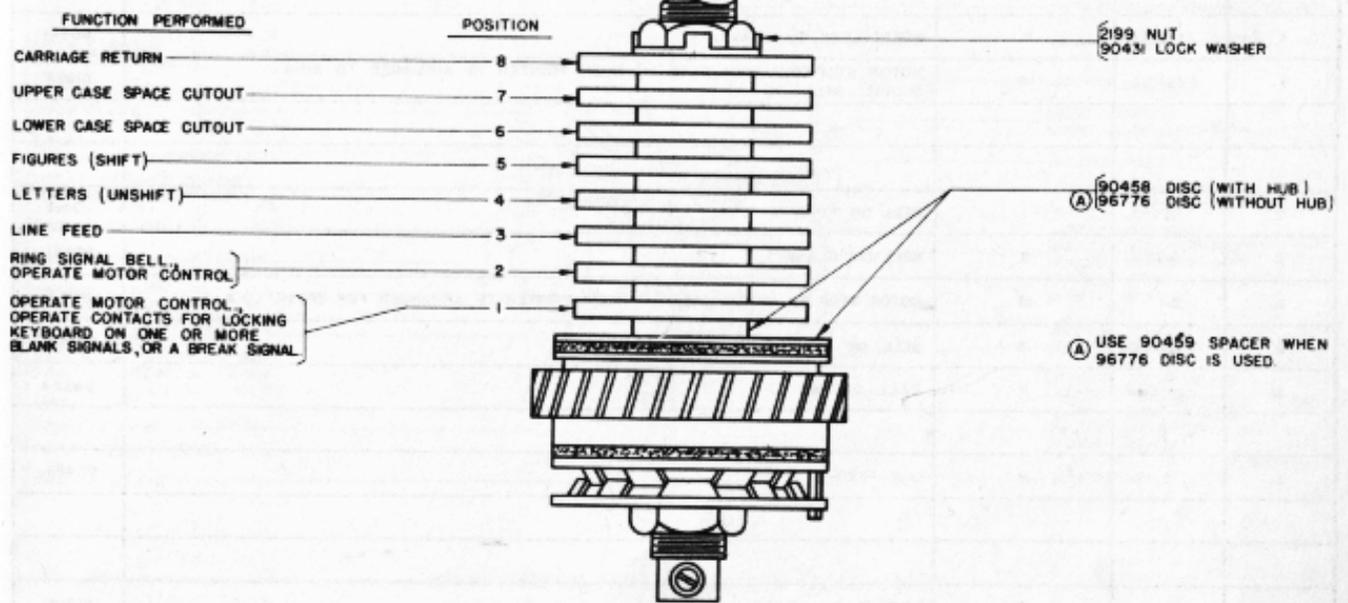

FUNCTION ARM PROJECTIONS
VIEWED FROM TOP OF FUNCTION CONTROL ASSEMBLY AS USED IN PRINTER

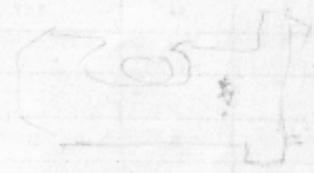

FUNCTION ARMS

POSITION USED	NUMBER STAMPED ON ARM	POSITION OF FUNCTION ARM PROJECTION	FUNCTION PERFORMED	CATALOG NUMBER
—	—	NONE	USED AS A SPACER WHEN FUNCTION ARM IS OMITTED.	90474
1	1-2	6	BREAK LOCK ON BLANK.	90461
1	2-1	18	MOTOR STOP ON UPPER CASE "H", WHEN PRINTER IS ARRANGED TO RING SIGNAL BELL.	91923
2	2	1	BELL ON FIGURES "S".	90462
2	1-2	6	BELL ON BLANK.	90461
2	2-1	18	MOTOR STOP ON UPPER CASE "H", WHEN PRINTER IS ARRANGED FOR BREAK LOCK.	91923
2	2A	15	BELL ON FIGURES "J".	90469
2	2-B	7	BELL ON "A"	99374
3	3	8	LINE FEED.	90463
4	4	27	UNSHIFT ON LETTERS.	91914
4	4A	2,27	UNSHIFT ON LETTERS AND SPACE.	90464
5	5	31	SHIFT ON FIGURES.	90465
6	6	8,14,27,31	BLOCKS SPACING ON LOWER CASE "LINE FEED", CARRIAGE RETURN, LETTERS AND FIGURES.	90472
6	6A	6,8,14,27,31	BLOCKS SPACING ON LOWER CASE "BLANK", LINE FEED, CARRIAGE RETURN, LETTERS, AND FIGURES.	90466
6	6B	6	BLOCKS SPACING ON LOWER CASE BLANK	99375
7	7	1,8,14,27,31	BLOCKS SPACING ON UPPER CASE "S", LINE FEED, CARRIAGE RETURN, LETTERS AND FIGURES.	90473
7	7A	1,6,8,14,27,31	BLOCKS SPACING ON UPPER CASE "S", BLANK, LINE FEED, CARRIAGE RETURN, LETTERS AND FIGURES.	90467
7	7B	6,8,14,15,27,31	BLOCKS SPACING ON UPPER CASE "BLANK", LINE FEED, CARRIAGE RETURN, "J", LETTERS AND FIGURES.	90470
7	7C	1,6,8,14,18,27,31	BLOCKS SPACING ON UPPER CASE "S", BLANK, LINE FEED, CARRIAGE RETURN, "H", LETTERS AND FIGURES.	91924
7	7D	8,14,15,27,31	BLOCKS SPACING ON UPPER CASE "LINE FEED", CARRIAGE RETURN, "J", LETTERS AND FIGURES.	96806
7	7E	8	BLOCKS SPACING ON UPPER CASE LINE FEED	99376
8	8	14	CARRIAGE RETURN	90468

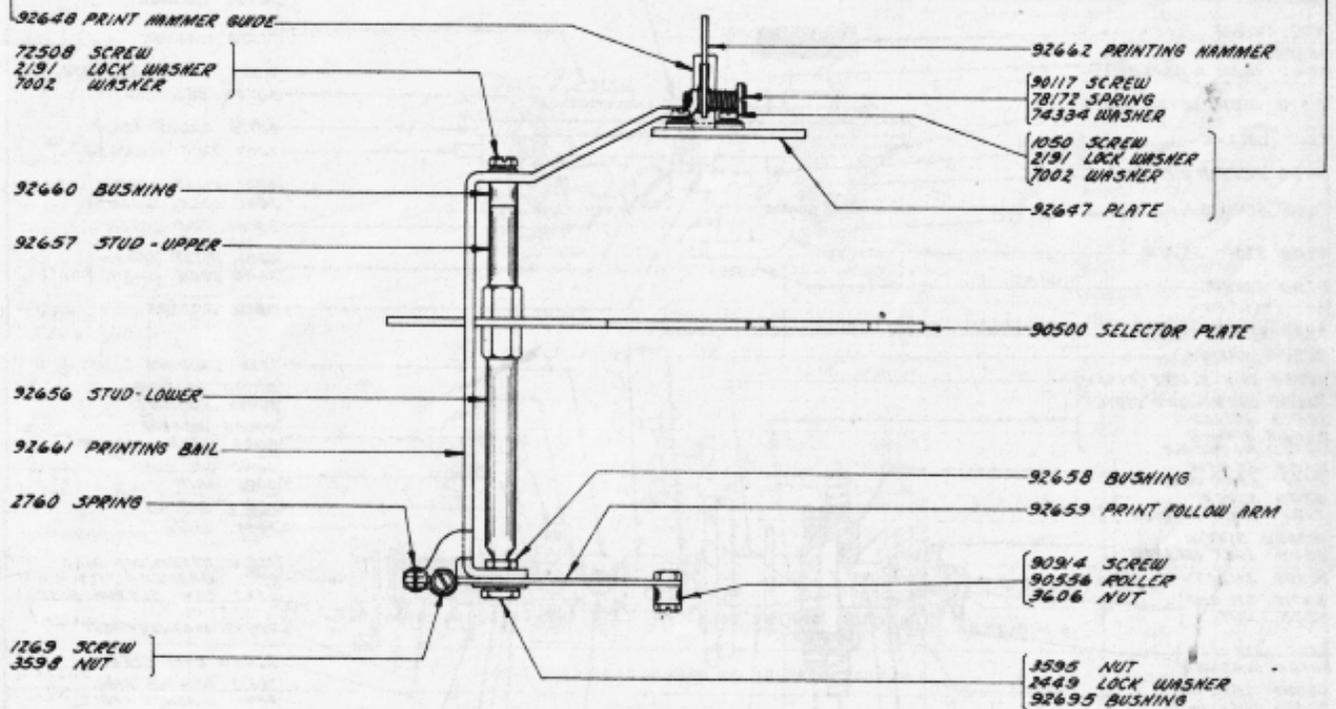
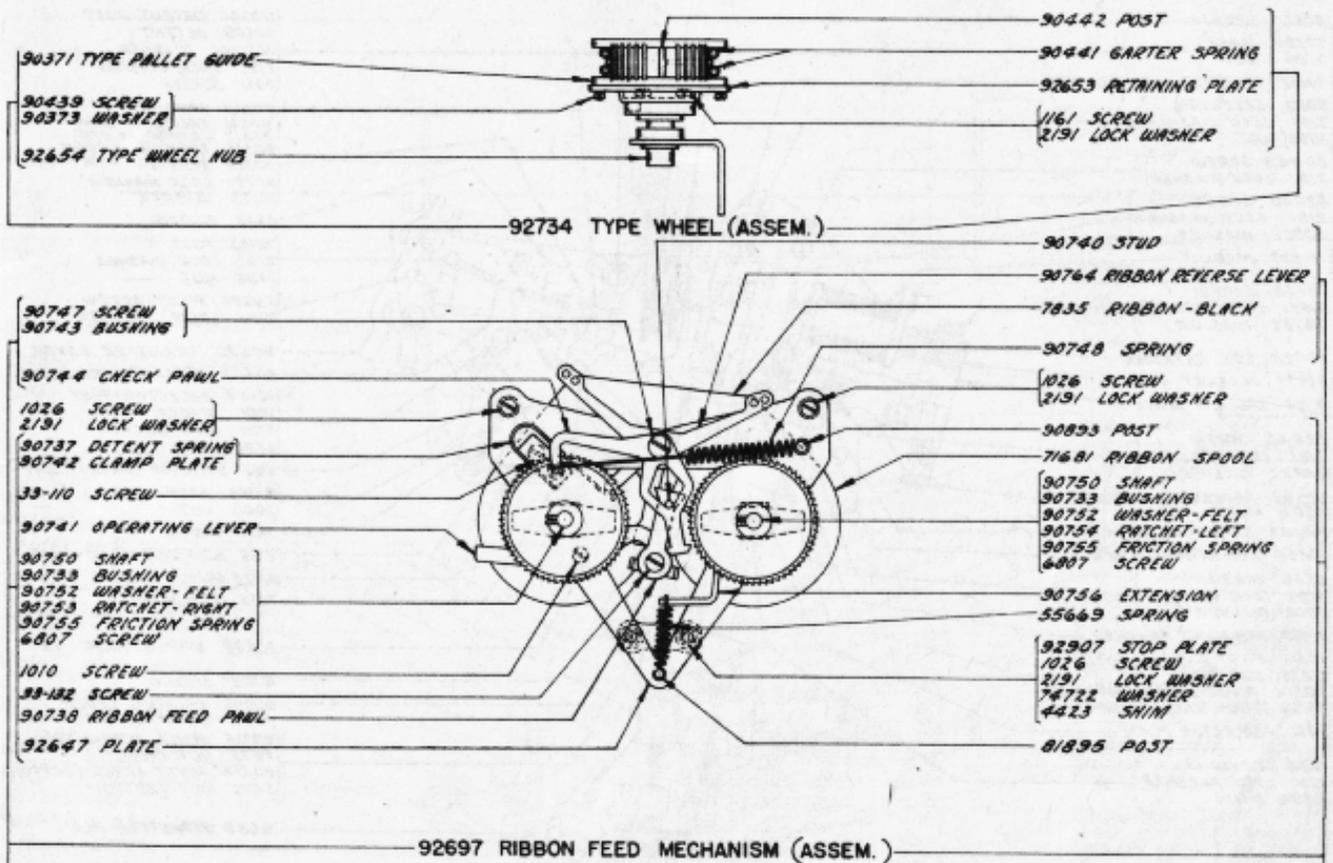

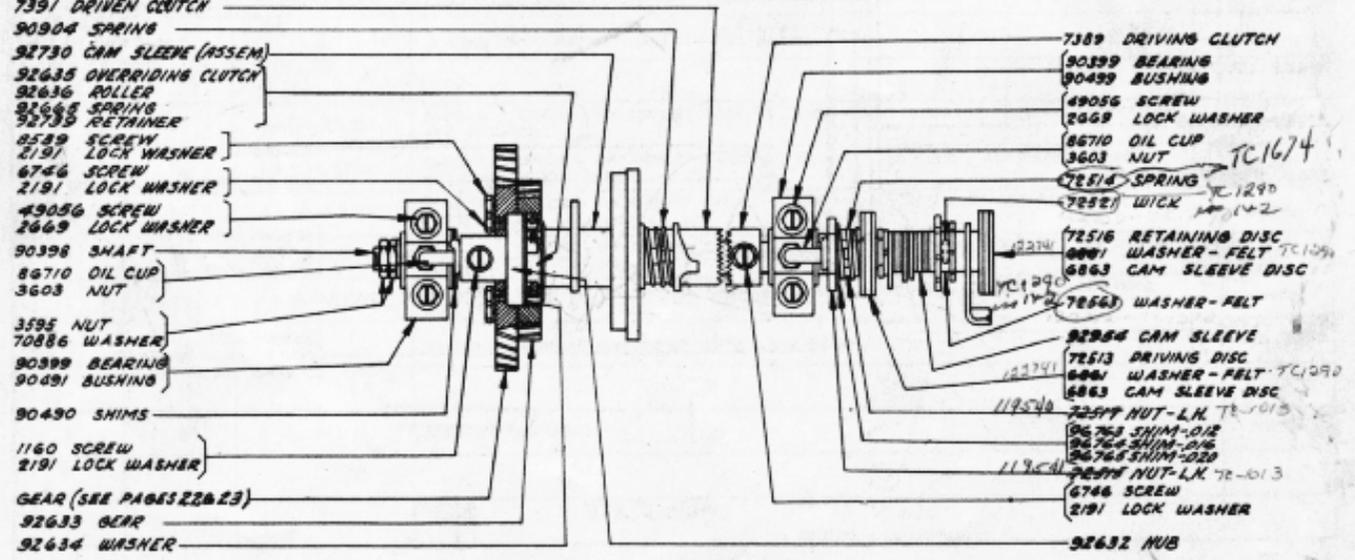
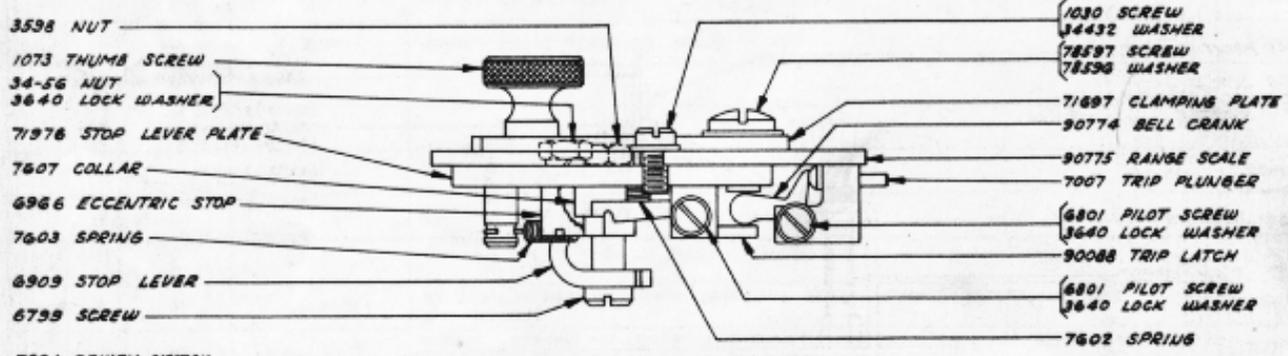
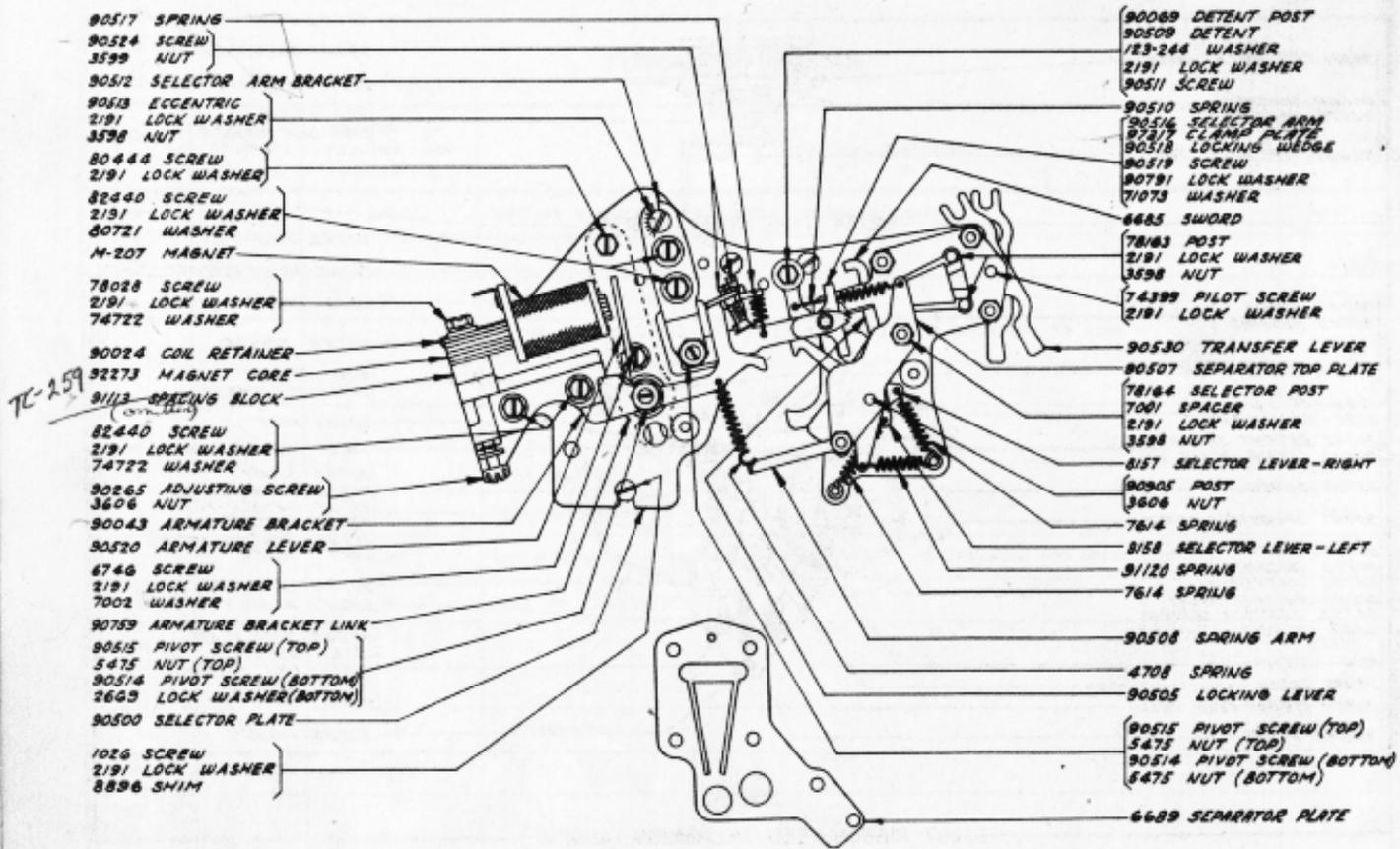

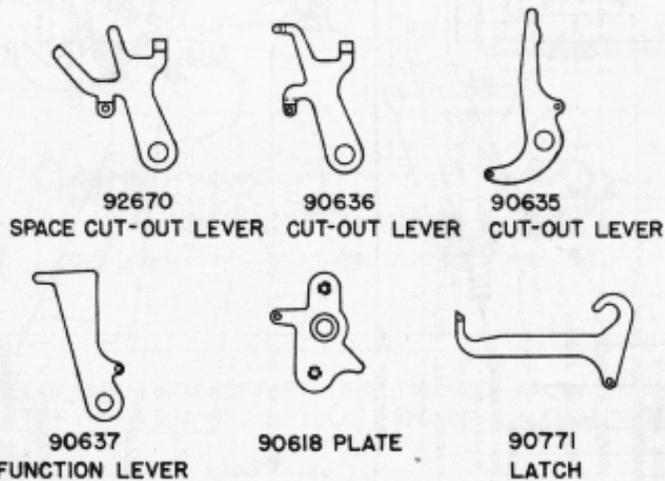
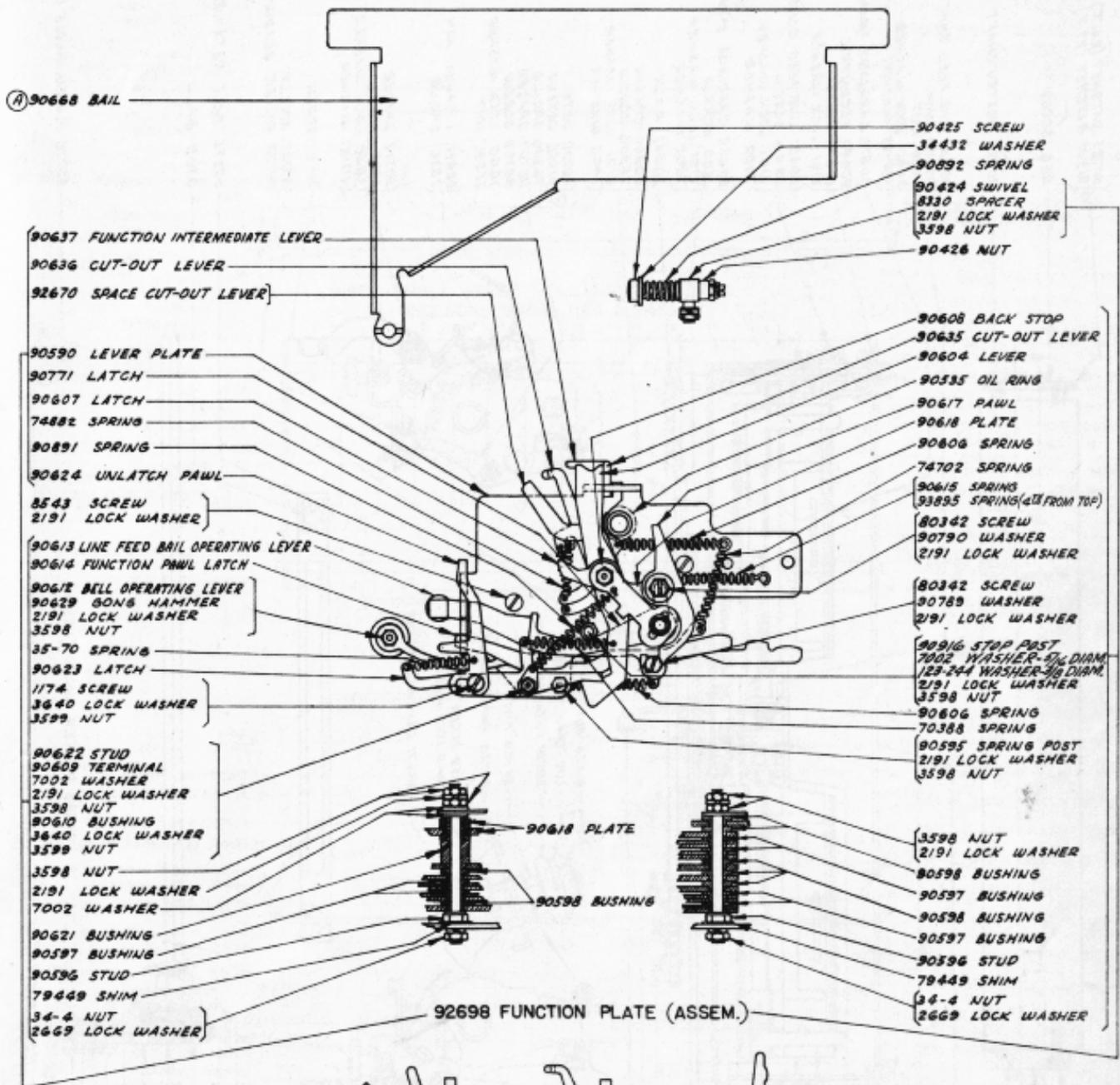

(A) SEE PAGE 32 FOR EXPLANATION

*33-42 narrow no new style clamp.
part TC-414*

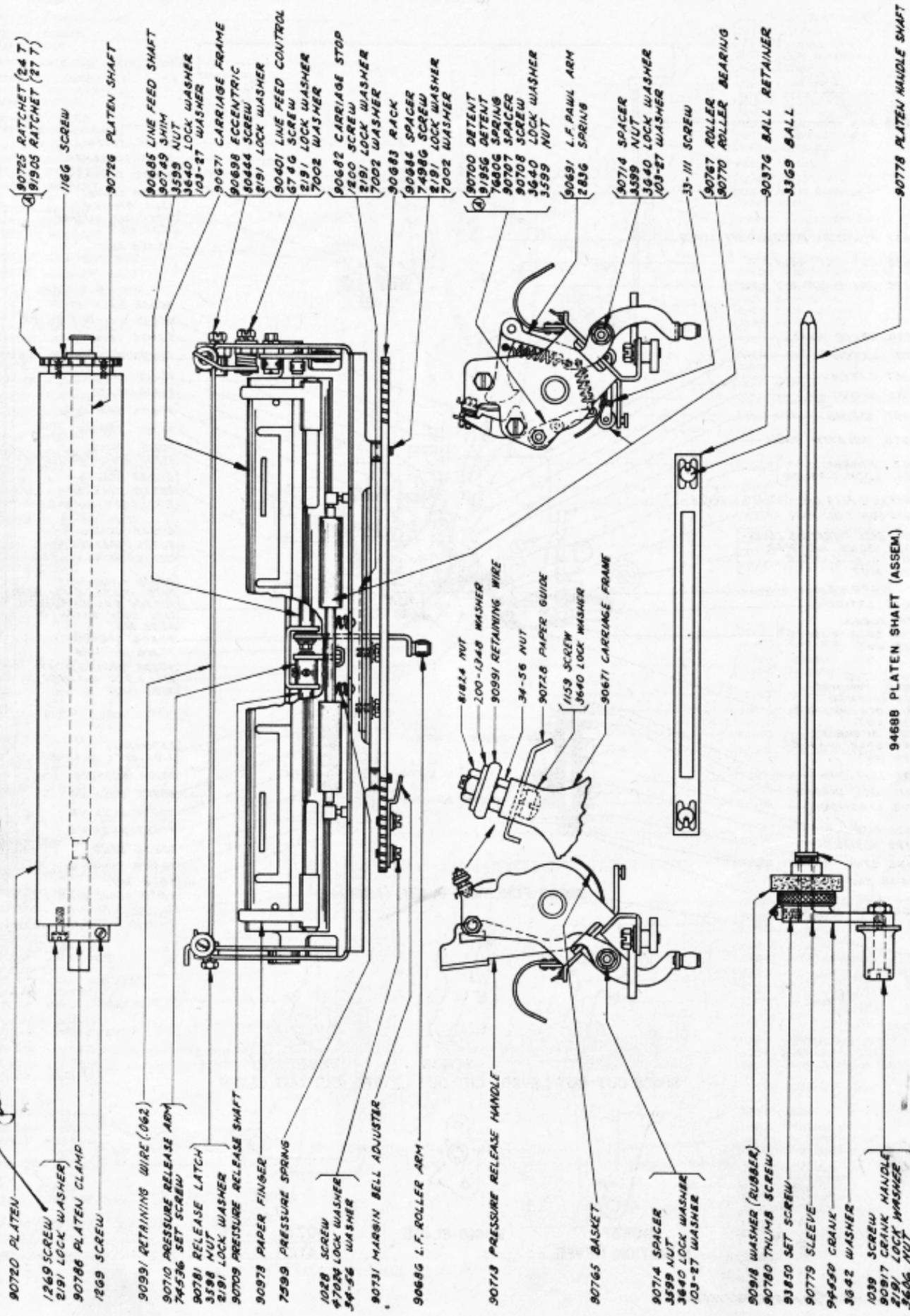

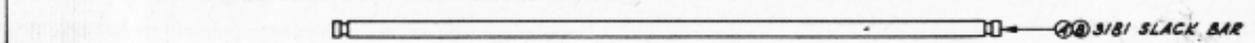
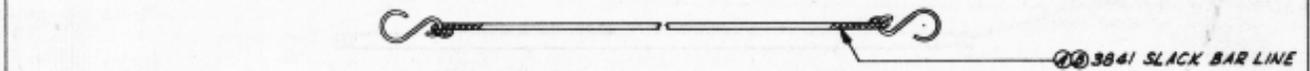
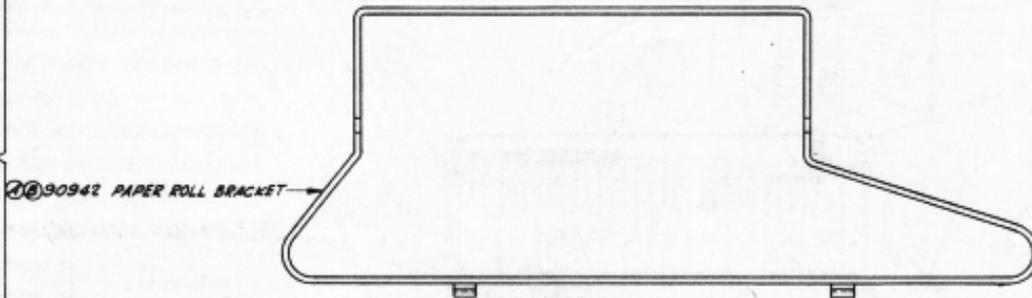
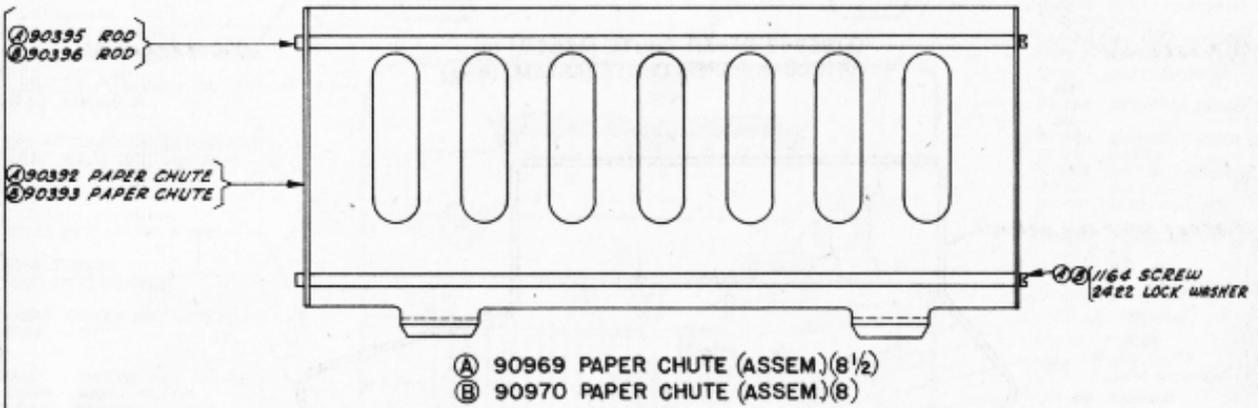
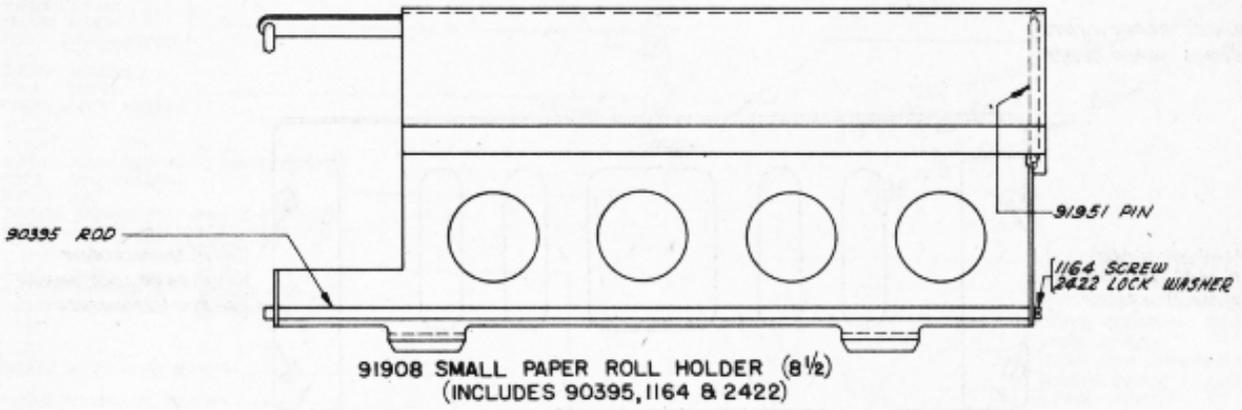

- ① 90968 SET OF PAPER BRACKET PARTS (B 1/2) (INCLUDES ALL PARTS MARKED ①)
- ② 90971 SET OF PAPER BRACKET PARTS (B) (INCLUDES ALL PARTS MARKED ②)

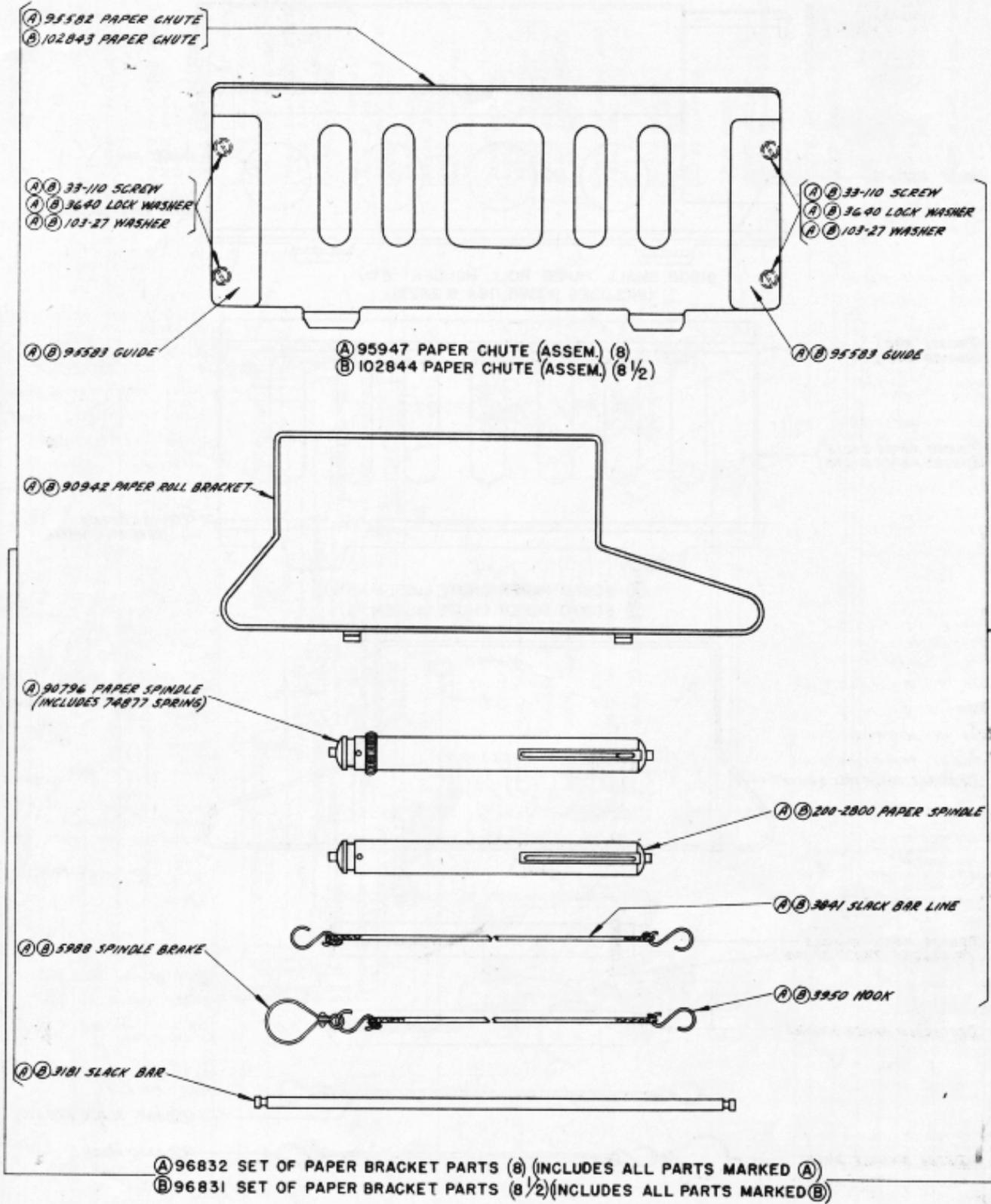

9854 Paper Slack Bar Assem = 1-3181, 2-3841,
Per W.S. memo - 1-24-47 47-3950, 1-5988
also, A & B 1/2

*106244 1000^W shunt resistor
TC 80V
93073 Station line resistor (welder)*

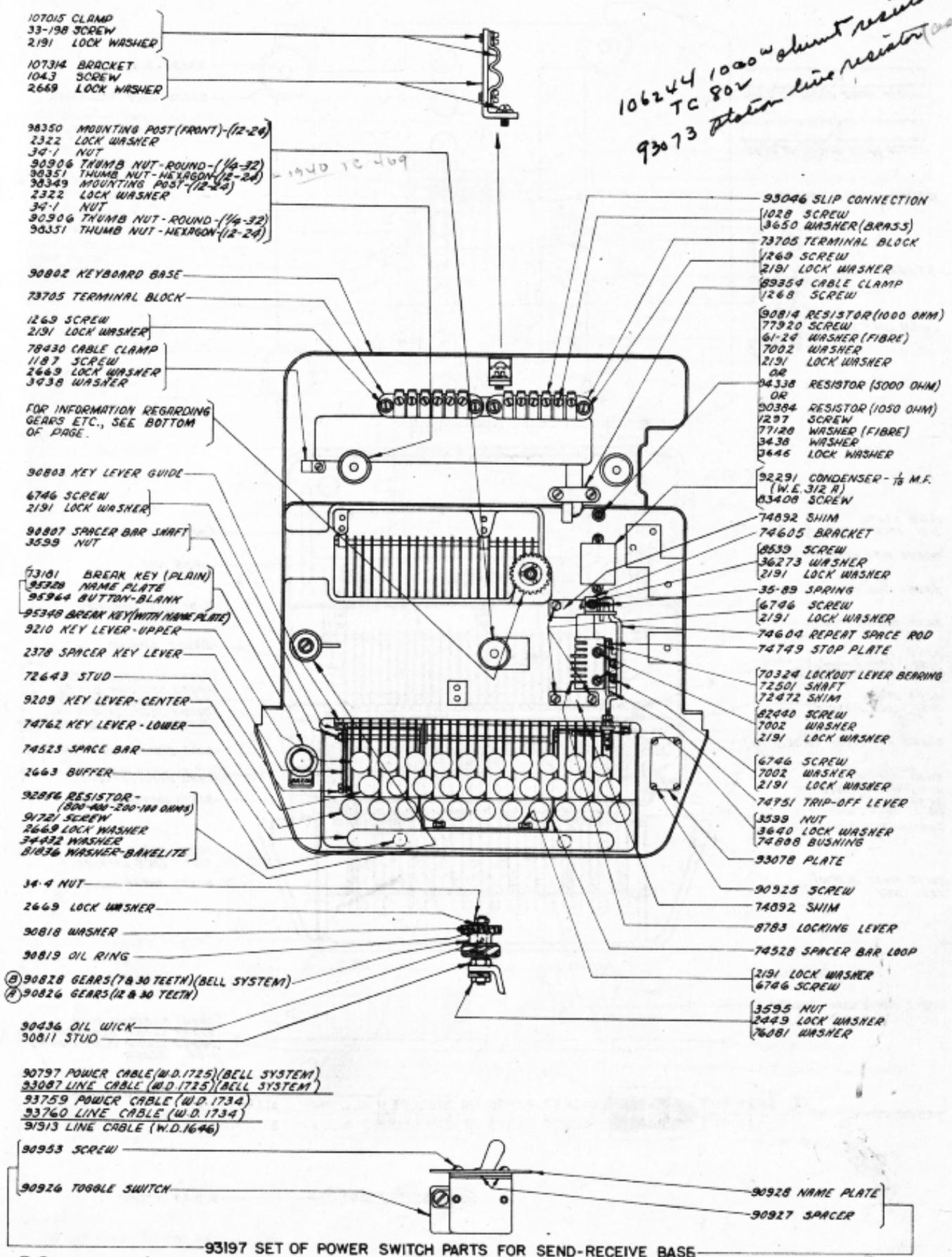

- 107015 CLAMP
- 33-198 SCREW
- 2191 LOCK WASHER
- 107314 BRACKET
- 1043 SCREW
- 2669 LOCK WASHER

- 98350 MOUNTING POST (FRONT) (12-24)
- 2322 LOCK WASHER
- 34-1 NUT
- 90906 THUMB NUT-ROUND (1/4-32)
- 90351 THUMB NUT-HEXAGON (12-24)
- 90349 MOUNTING POST (12-24)
- 2322 LOCK WASHER
- 34-1 NUT
- 90906 THUMB NUT-ROUND (1/4-32)
- 90351 THUMB NUT-HEXAGON (12-24)

- 90802 KEYBOARD BASE
- 73705 TERMINAL BLOCK
- 1269 SCREW
- 2191 LOCK WASHER
- 78430 CABLE CLAMP
- 1187 SCREW
- 2669 LOCK WASHER
- 3438 WASHER

FOR INFORMATION REGARDING GEARS ETC., SEE BOTTOM OF PAGE.

- 90803 KEY LEVER GUIDE
- 6746 SCREW
- 2191 LOCK WASHER
- 90807 SPACER BAR SHAFT
- 3599 NUT

- 73101 BREAK KEY (PLAIN)
- 95320 NAME PLATE
- 95964 BUTTON-BLANK
- 95348 BREAK KEY (WITH NAME PLATE)
- 9210 KEY LEVER-UPPER

- 2378 SPACER KEY LEVER
- 72643 STUD
- 9209 KEY LEVER-CENTER
- 74762 KEY LEVER-LOWER
- 74523 SPACE BAR

- 2663 BUFFER
- 92896 RESISTOR (500-100-200-100 OHMS)
- 91221 SCREW
- 2669 LOCK WASHER
- 34422 WASHER
- 81036 WASHER-BANALITE

- 34-4 NUT
- 2669 LOCK WASHER
- 90818 WASHER
- 90819 OIL RING

- 90828 GEARS (7 & 30 TEETH) (BELL SYSTEM)
- 90826 GEARS (12 & 30 TEETH)

- 90436 OIL WICK
- 90811 STUD

- 90797 POWER CABLE (W.D. 1725) (BELL SYSTEM)
- 93087 LINE CABLE (W.D. 1725) (BELL SYSTEM)
- 93759 POWER CABLE (W.D. 1734)
- 93760 LINE CABLE (W.D. 1734)
- 91313 LINE CABLE (W.D. 1646)

- 90953 SCREW

- 90926 TOGGLE SWITCH

- 93046 SLIP CONNECTION
- 1028 SCREW
- 3650 WASHER (BRASS)
- 73705 TERMINAL BLOCK
- 1269 SCREW
- 2191 LOCK WASHER
- 89354 CABLE CLAMP
- 1268 SCREW
- 90814 RESISTOR (1000 OHM)
- 77920 SCREW
- 61-24 WASHER (FIBRE)
- 7002 WASHER
- 2191 LOCK WASHER
- OR
- 94338 RESISTOR (5000 OHM)
- OR
- 90384 RESISTOR (1050 OHM)
- 1297 SCREW
- 77120 WASHER (FIBRE)
- 3438 WASHER
- 2646 LOCK WASHER

- 92291 CONDENSER - 1/8 M.F. (W.E. 312 A)
- 83408 SCREW

- 74892 SHIM
- 74605 BRACKET
- 8539 SCREW
- 36273 WASHER
- 2191 LOCK WASHER
- 35-89 SPRING
- 6746 SCREW
- 2191 LOCK WASHER
- 74604 REPEAT SPACE ROD
- 74749 STOP PLATE

- 70324 LOCKOUT LEVER BEARING
- 72501 SHAFT
- 72472 SHIM
- 82440 SCREW
- 7002 WASHER
- 2191 LOCK WASHER

- 6746 SCREW
- 7002 WASHER
- 2191 LOCK WASHER
- 74751 TRIP-OFF LEVER
- 3599 NUT
- 3640 LOCK WASHER
- 74808 BUSHING
- 93078 PLATE

- 90925 SCREW
- 74092 SHIM
- 8783 LOCKING LEVER
- 74528 SPACER BAR LOOP

- 2191 LOCK WASHER
- 6746 SCREW
- 3595 NUT
- 2449 LOCK WASHER
- 76081 WASHER

- 90928 NAME PLATE
- 90927 SPACER

93197 SET OF POWER SWITCH PARTS FOR SEND-RECEIVE BASE

(A)(B) SEE PAGE 32 FOR EXPLANATION

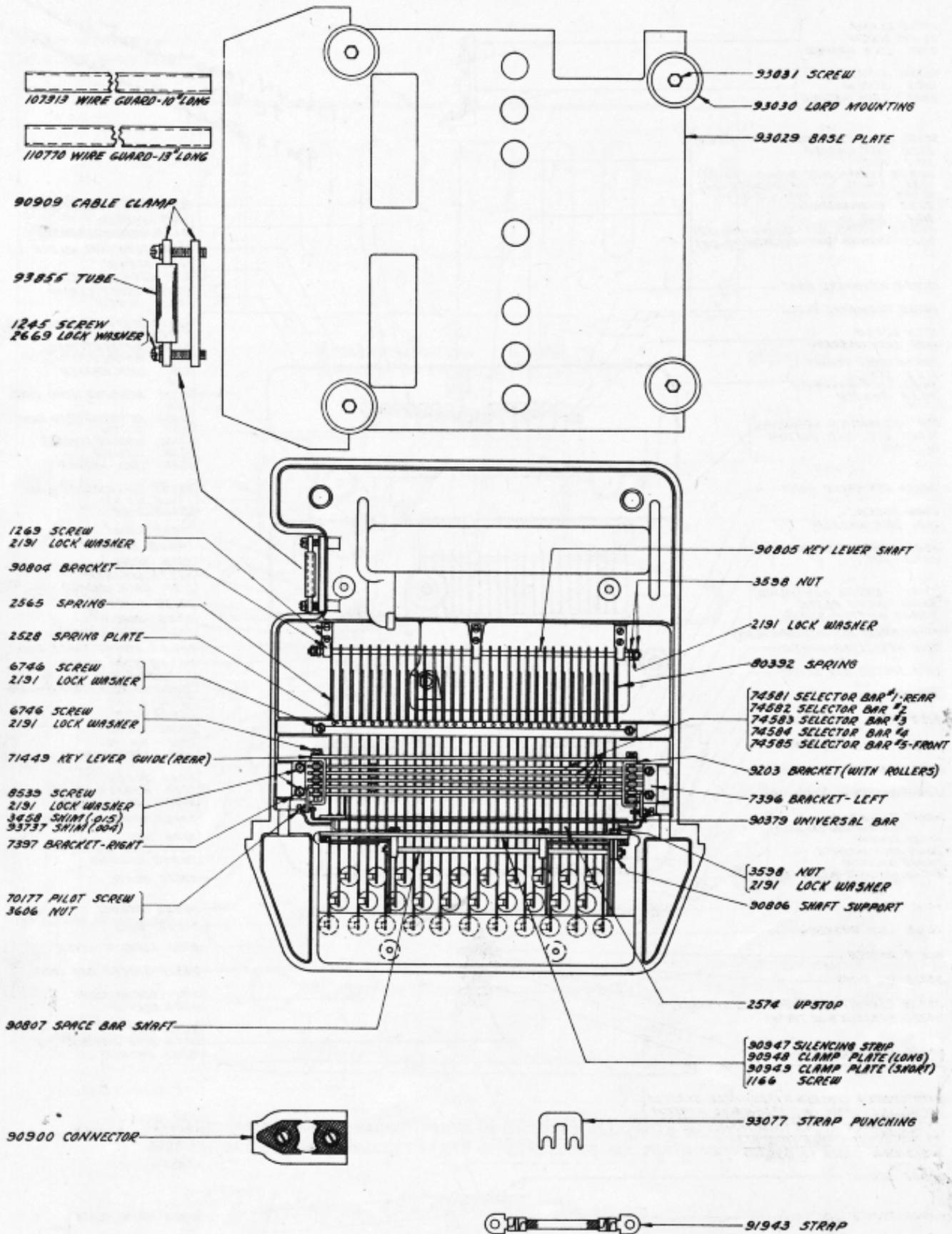

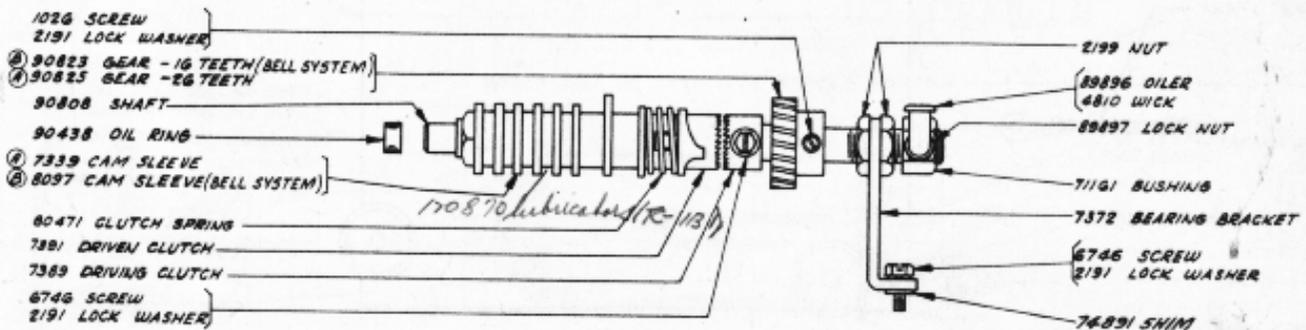
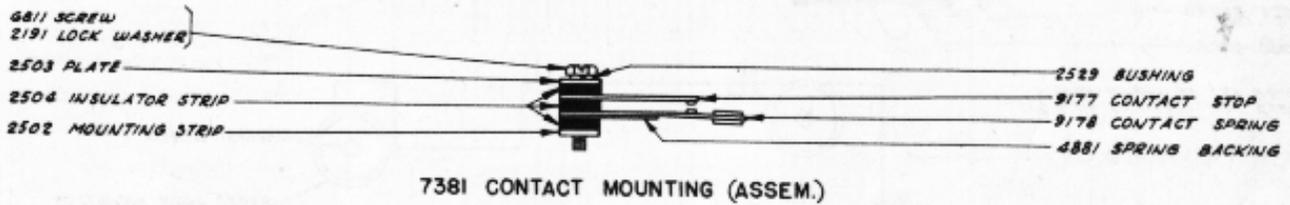
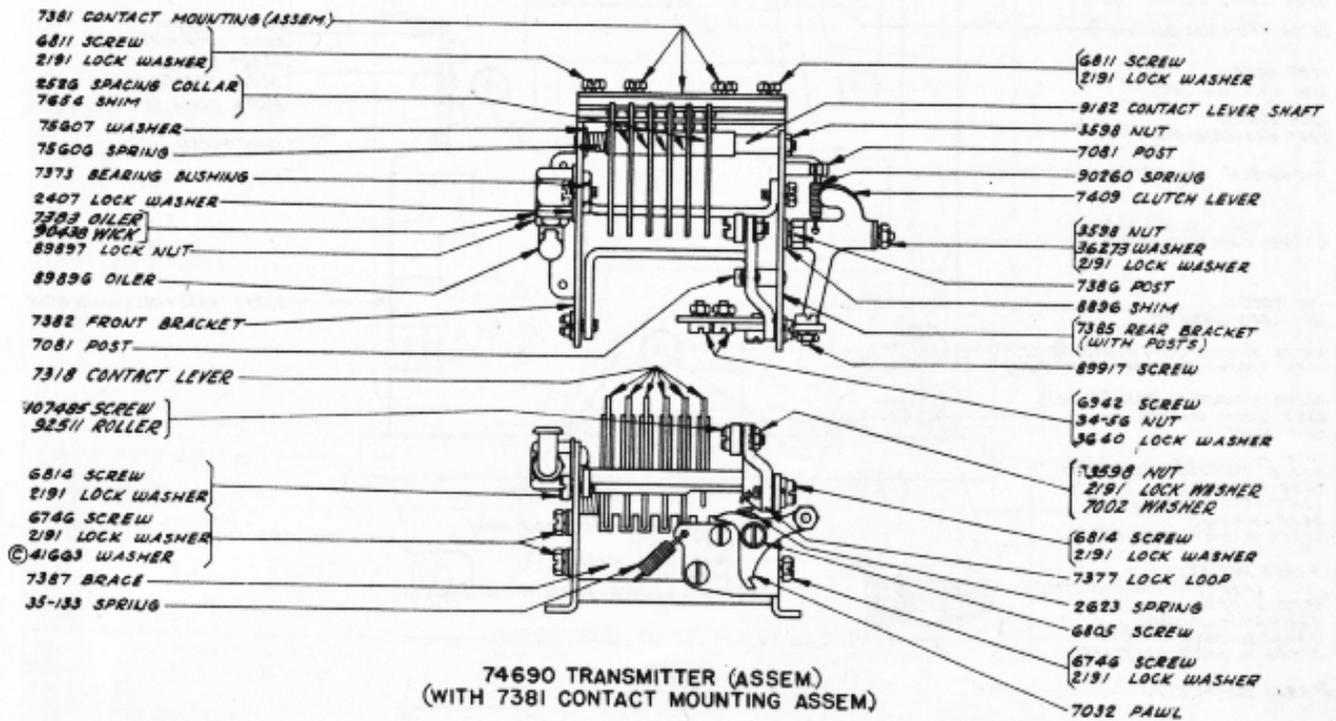

NOTE
①②③ SEE PAGE #22 FOR EXPLANATION

106244 1000 w sheet
resistor - TC-802
93073 station line
resistor!

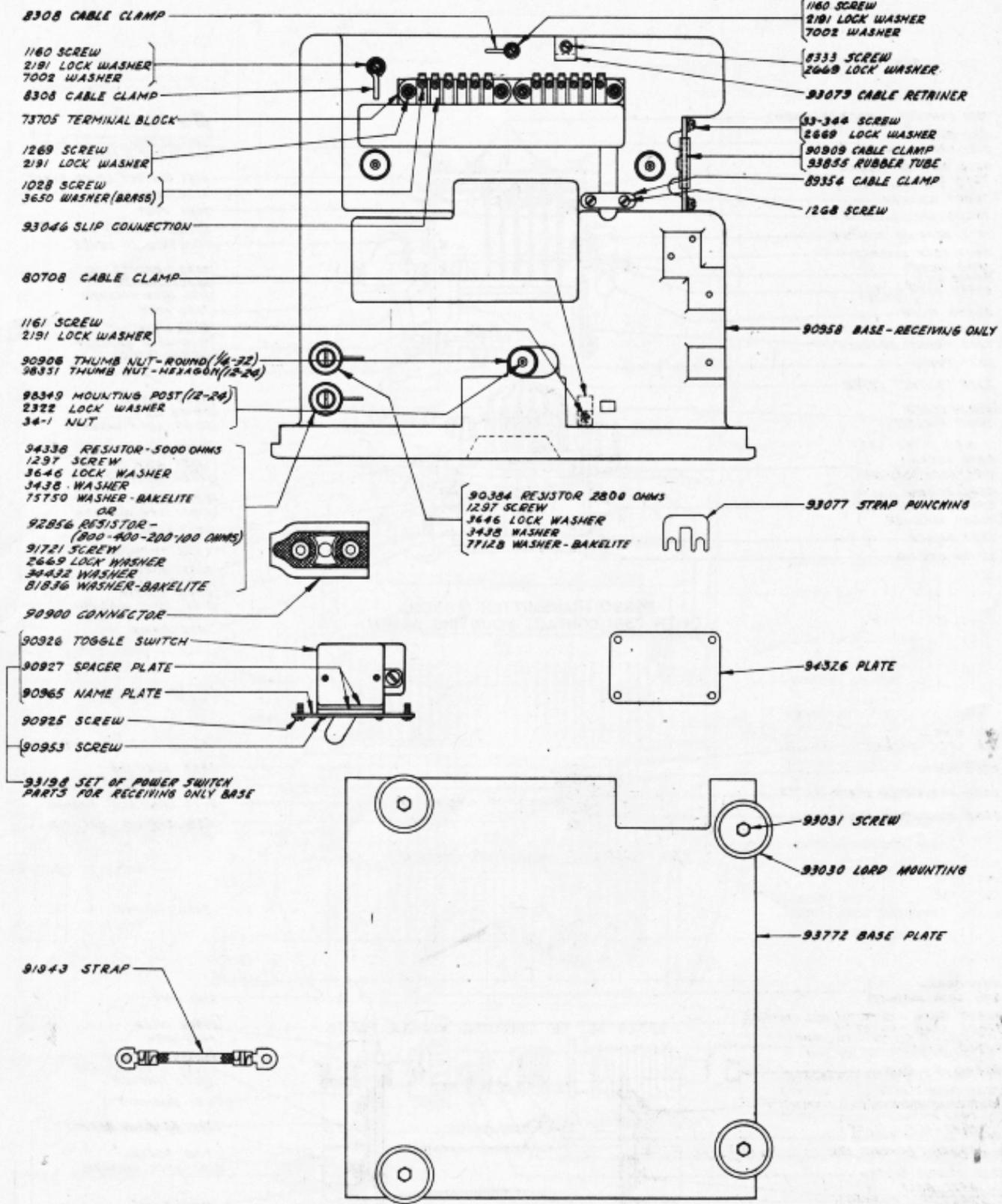

- 91912 POWER CABLE-W.D.1646, W.D.1752 (BELL SYSTEM)
- 90966 LINE CABLE-W.D.1646
- 93088 LINE CABLE-W.D.1752 (BELL SYSTEM)
- 91952 LINE CABLE-W.D.1646(BELL SYSTEM)

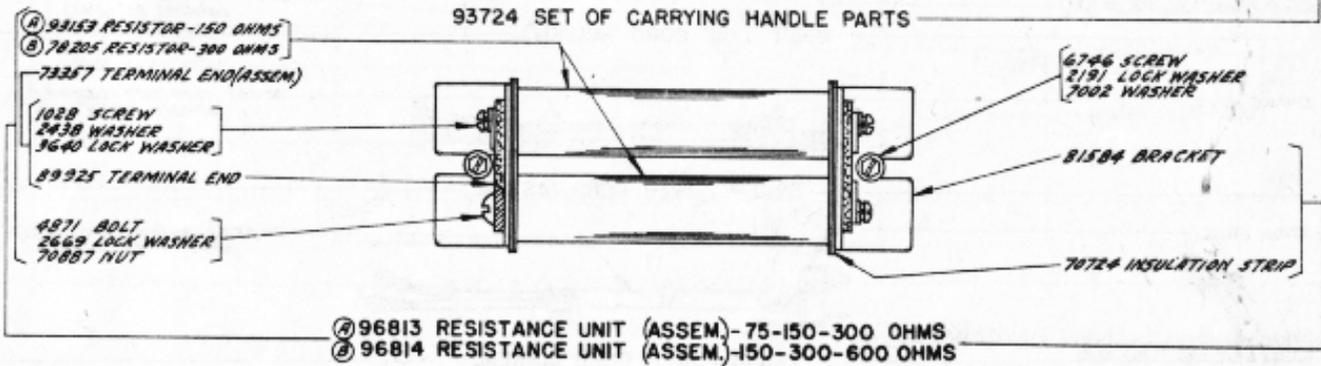
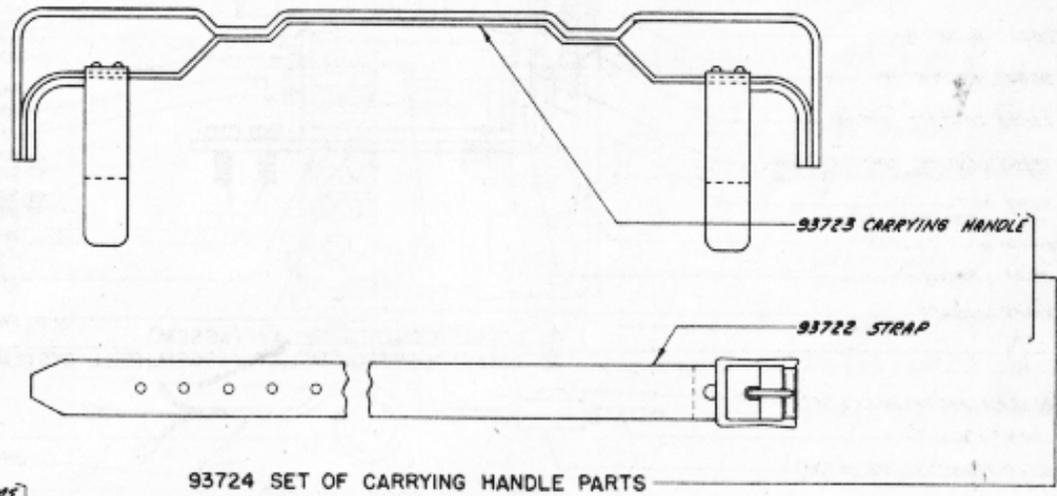
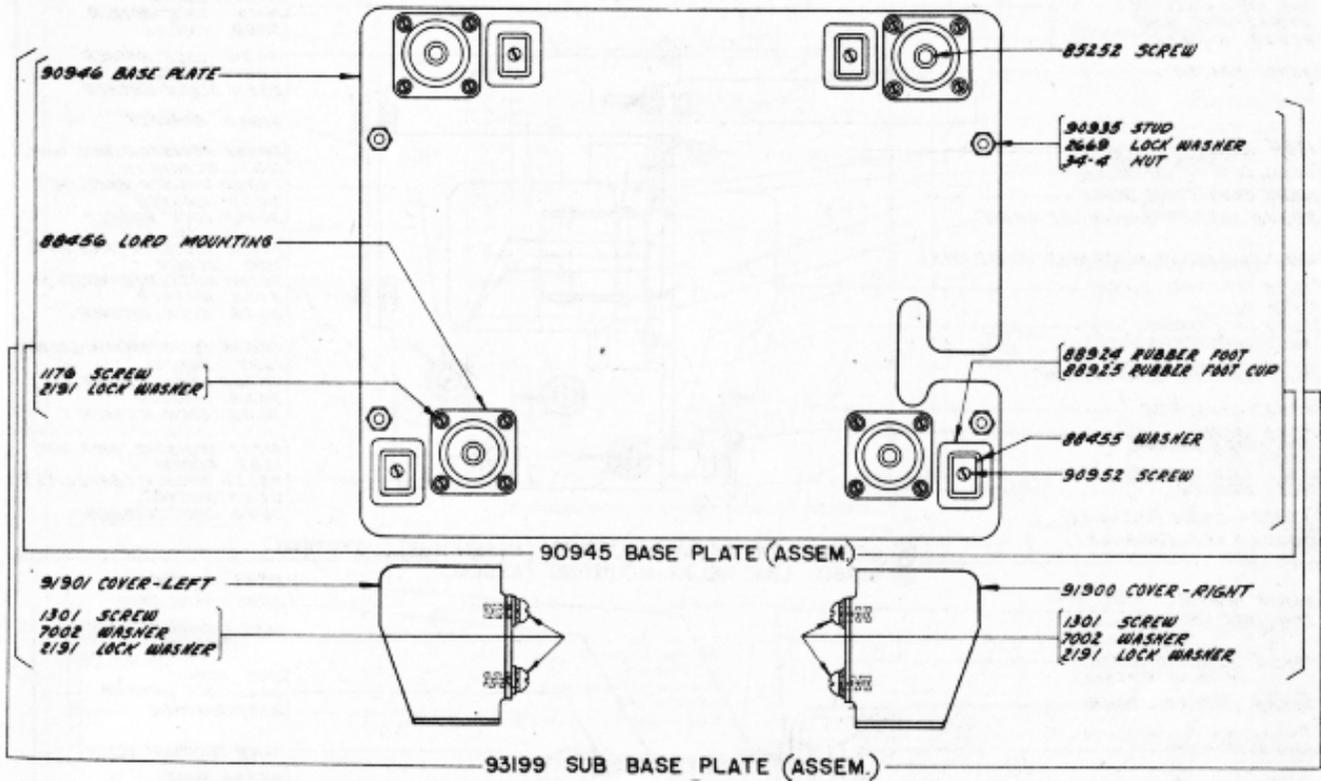

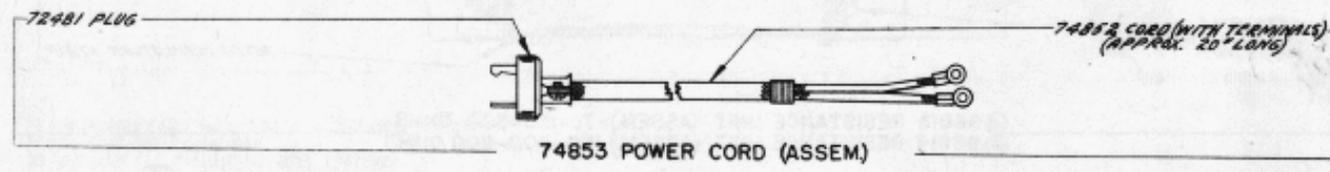
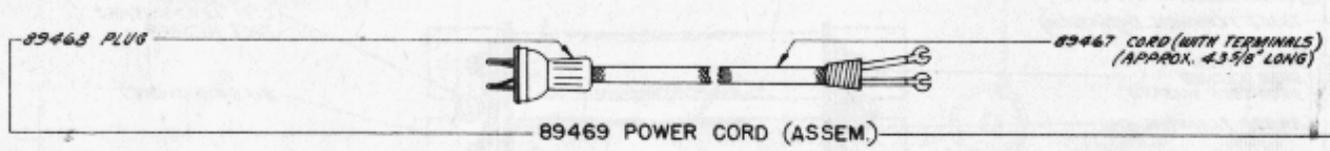
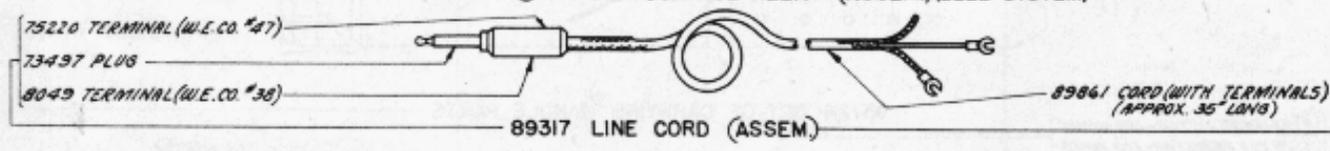
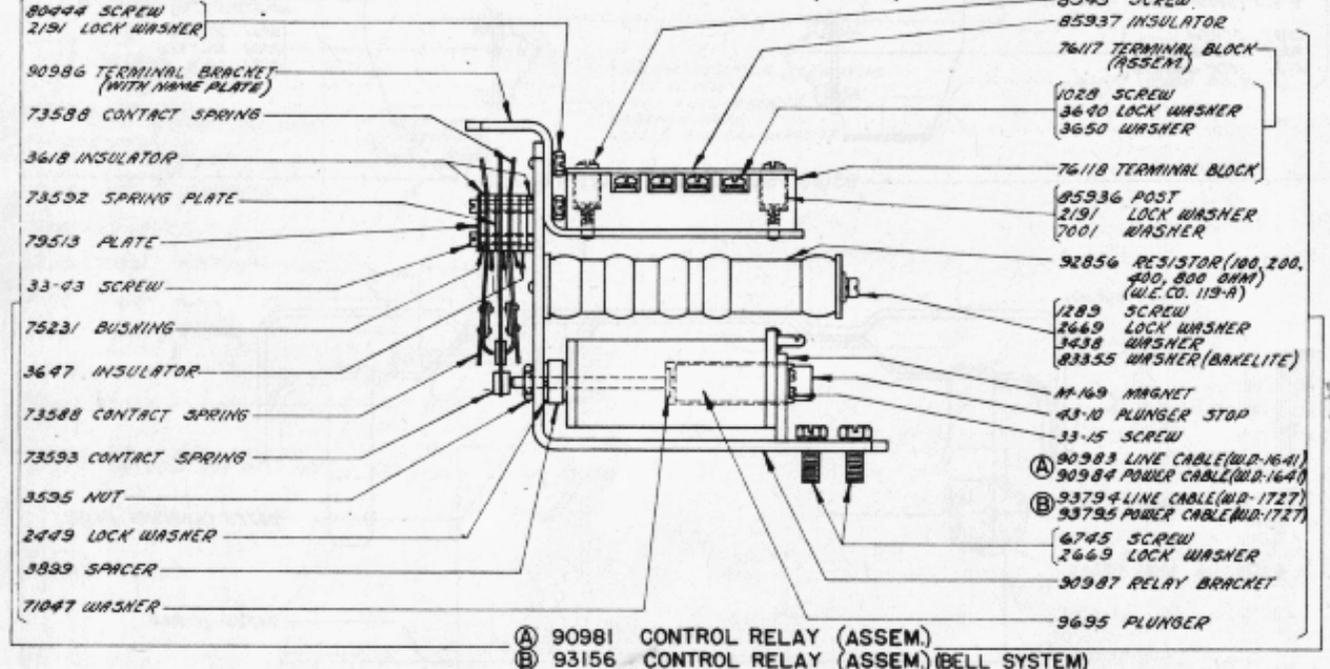
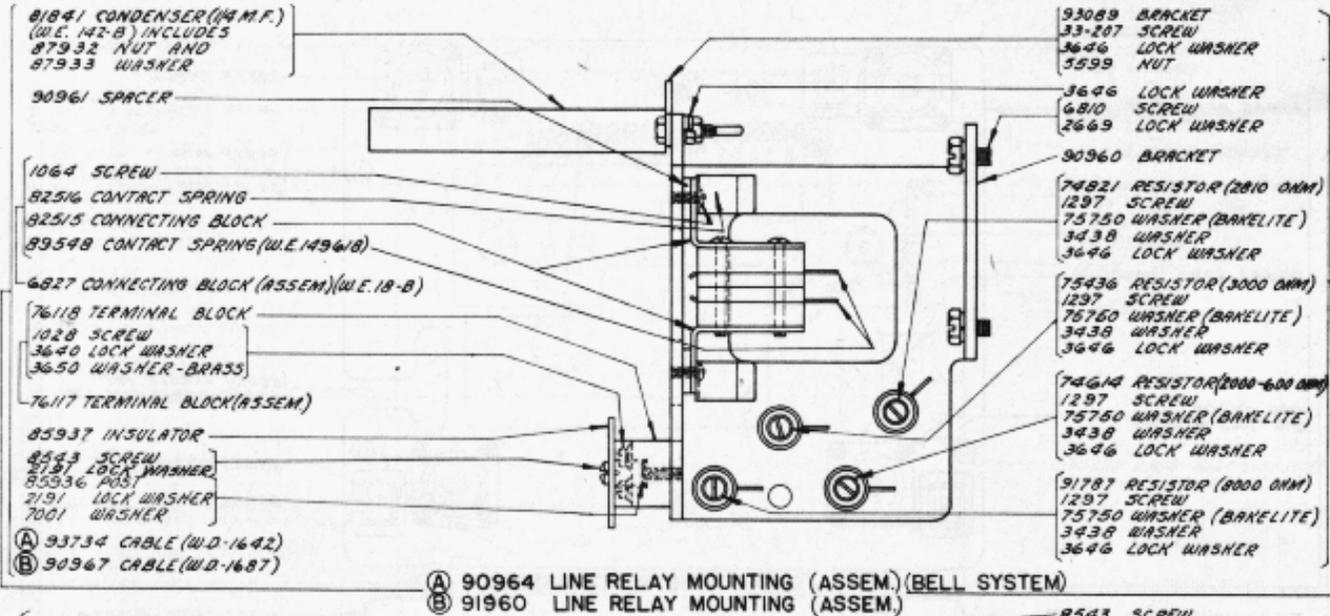

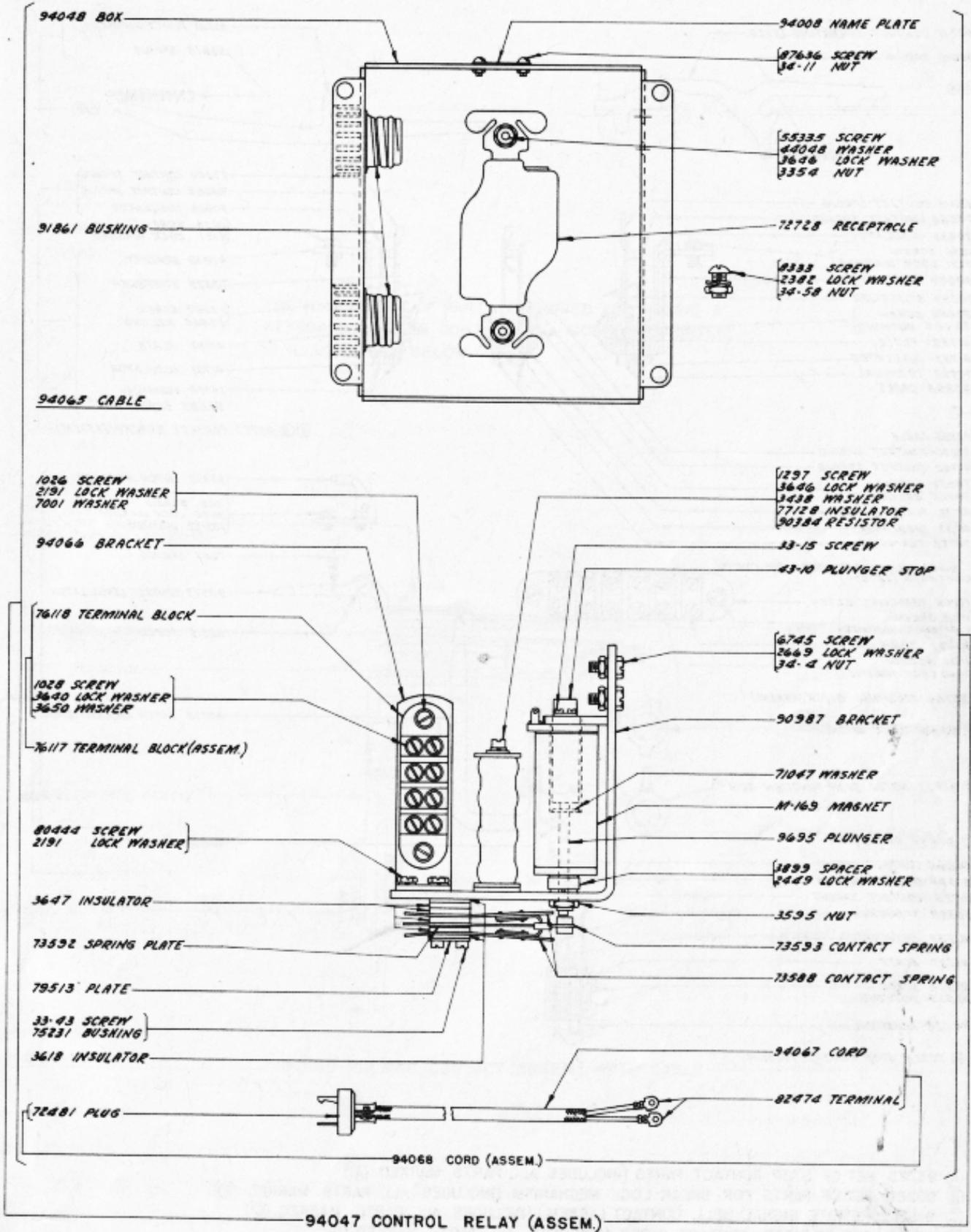

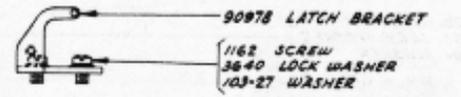
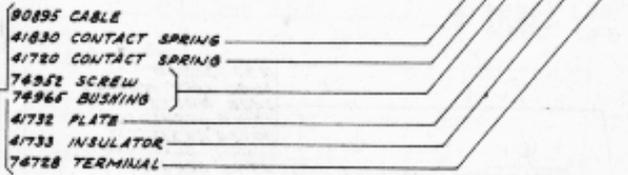
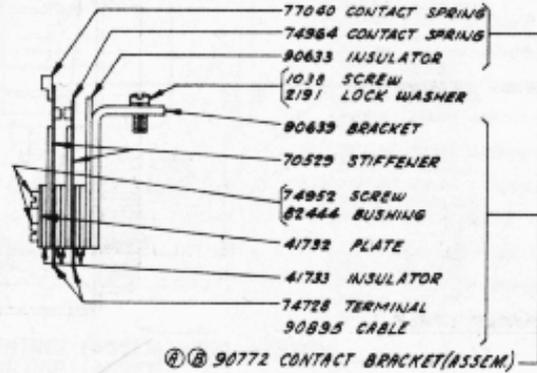
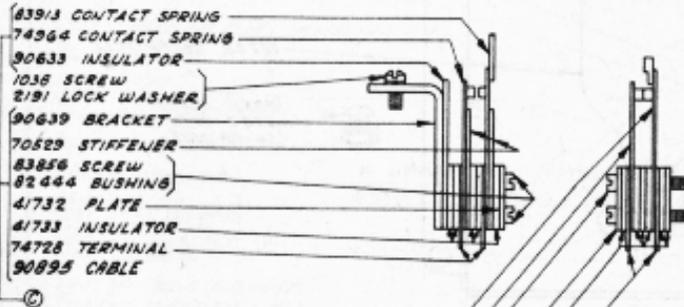
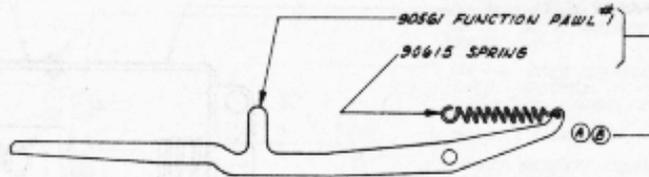
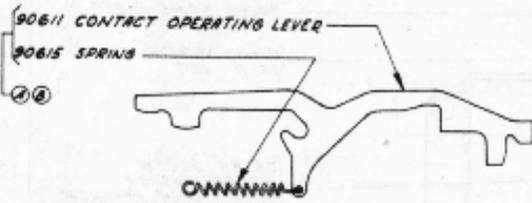

91909 TRANSMITTER DISTRIBUTOR CONTROL CONTACTS (ASSEM.)

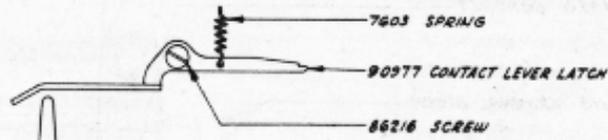
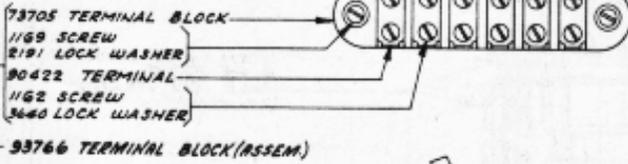

90431 LOCK WASHER



91923 MOTOR STOP FUNCTION ARM #1



90895 CABLE

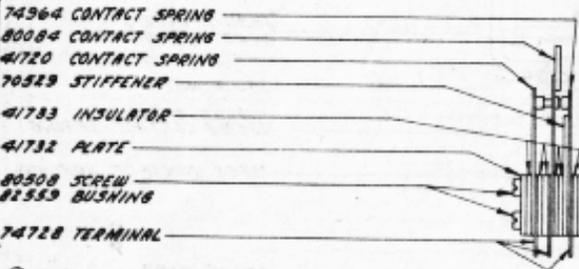

91724 STOP CONTACT (ASSEM.)

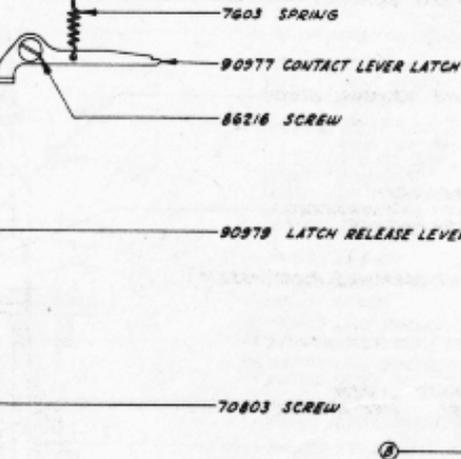

- (A) 93725 SET OF STOP CONTACT PARTS (INCLUDES ALL PARTS MARKED (A))
- (B) 90989 SET OF PARTS FOR BREAK-LOCK MECHANISM (INCLUDES ALL PARTS MARKED (B))
- (C) 91911 REMOTE SIGNAL BELL CONTACT (ASSEM.) (INCLUDES ALL PARTS MARKED (C))
- (D) 91722 SET OF STOP CONTACT PARTS (INCLUDES ALL PARTS MARKED (D))

THE 104668 SET OF PARTS, REQUIRED FOR ADDING A
KEYBOARD PULSING CONTACT TO A MODEL 26 PRINTER,
IS ILLUSTRATED BELOW.

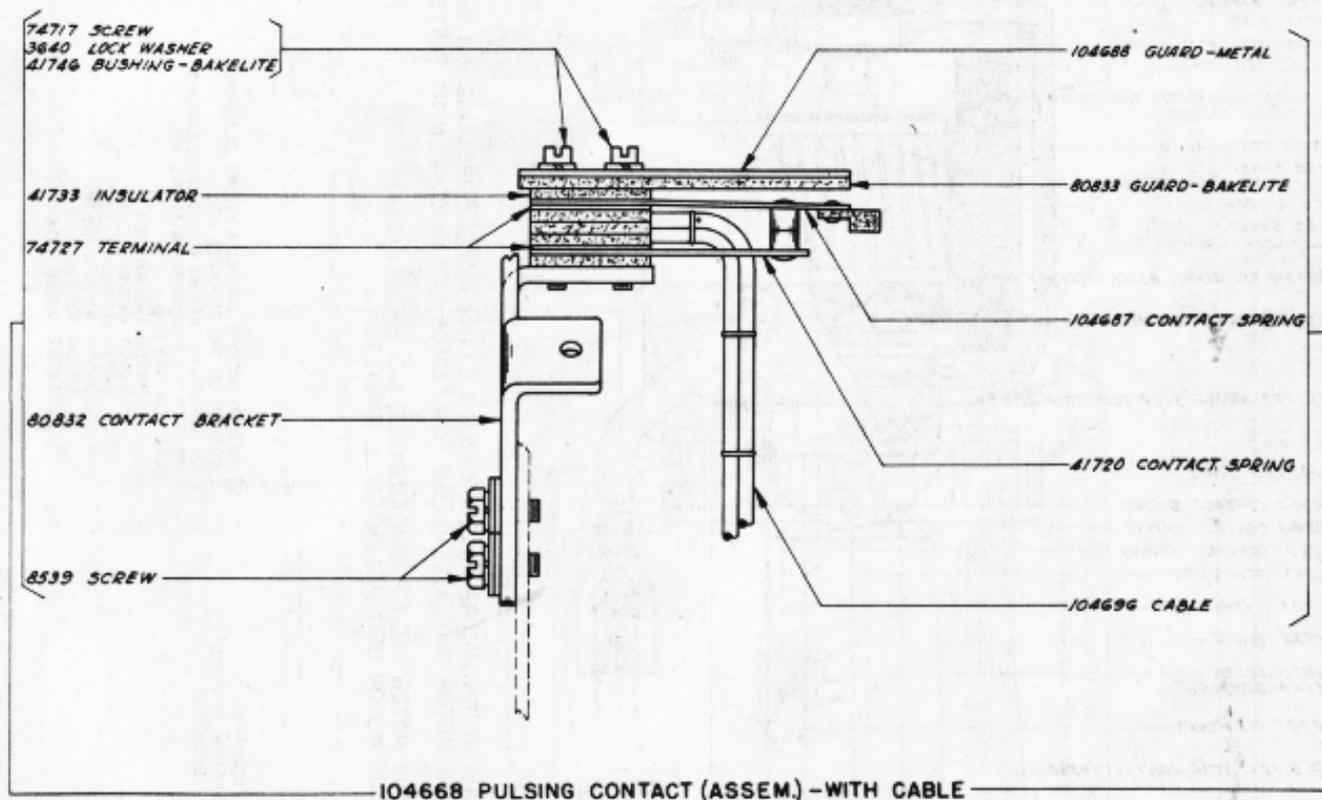

NOTE: SET OF STOP CONTACT PARTS (INCLUDING ALL PARTS MARKED (A))
IS REQUIRED FOR PROPER LOCK MECHANISM (WASHER AND CONTACT SPRING)
① REMOVE SIGNAL BY CONTACT (SEEN) (INCLUDE ALL PARTS MARKED (B))
② SET OF STOP CONTACT PARTS (INCLUDING ALL PARTS MARKED (C))

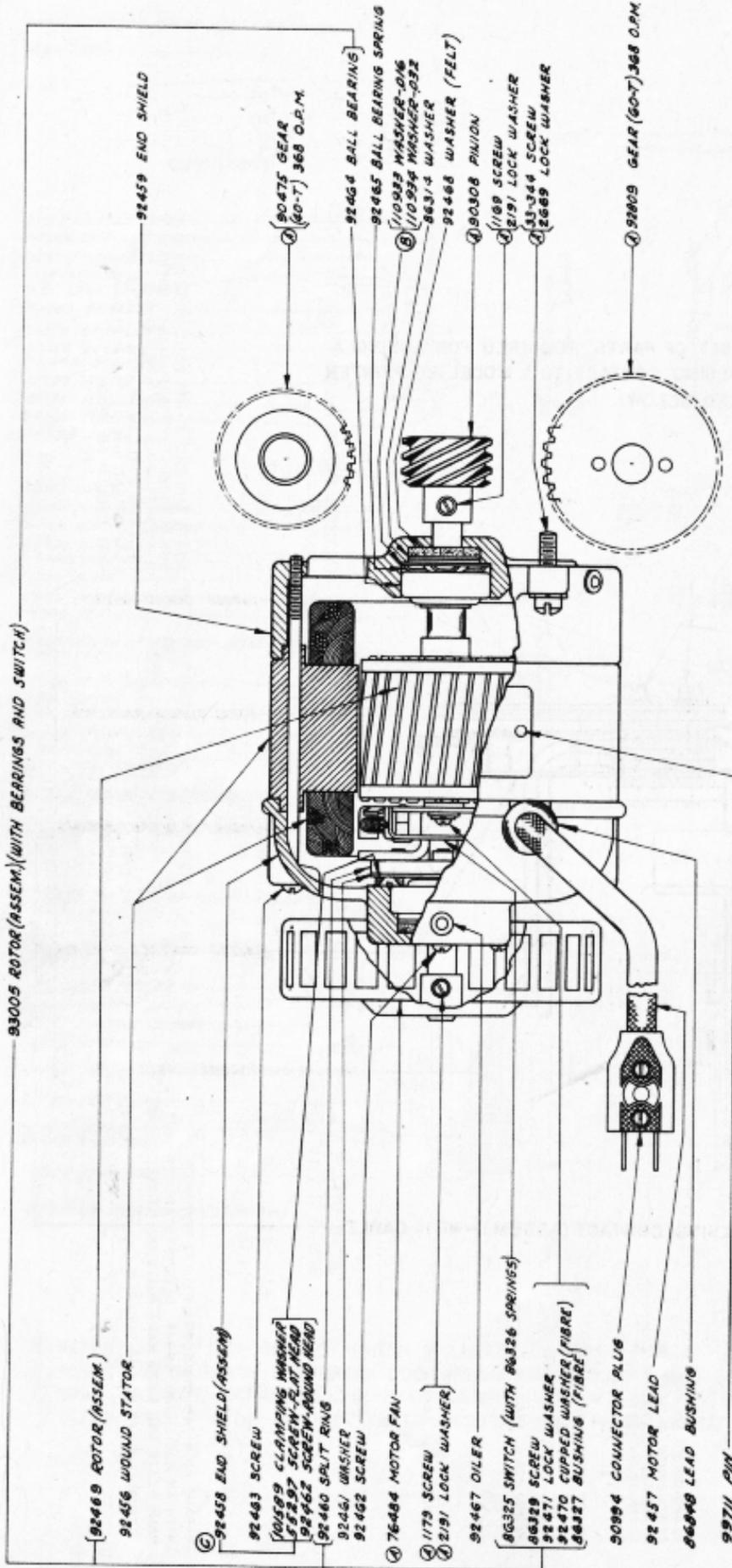

90305 SYNCHRONOUS MOTOR 1/40 H.P., 110V., 60 CYCLE A.C., (H.C. MODEL #RBS-4416 OR S-9014) (EXCLUDES PARTS MARKED (A))

90420 SYNCHRONOUS MOTOR UNIT (ASSEM) (SEE PAGE #29 FOR LIST OF COMPONENT PARTS)

* 94050 SYNCHRONOUS MOTOR 1/40 H.P., 110V., 60 CYCLE A.C. (BELL SYSTEM)

* 94044 SYNCHRONOUS MOTOR UNIT (ASSEM) (BELL SYSTEM)

* SAME AS 90305 AND 90420 EXCEPT EQUIPPED WITH AN ADDITIONAL 89946 "BELL SYSTEM SERVICE" NAME PLATE AND 91685 NAME PLATE MOUNTING SCREWS.

(B) USED ON MOTORS HAVING A 101589 CLAMPING WASHER ON THE OPPOSITE END. ON MOTORS NOT HAVING A 101589 CLAMPING WASHER THE FOLLOWING WASHERS ARE USED ON THIS END.

- 94552 WASHER .008
- 94553 WASHER .0079
- 94554 WASHER .0112
- 94555 WASHER .0159
- 94556 WASHER .032
- 94557 WASHER .0641

(C) 92458 END SHIELD-HAS BEEN REDESIGNED BUT RETAINS ITS ORIGINAL PART NUMBER. WHEN REPLACING OLD STYLE END SHIELD WITH NEW STYLE (WIRE OUTLET HOLE ON EDGE OF END SHIELD) THE FOLLOWING PART SHOULD BE ORDERED:
86848 LEAD BUSHING

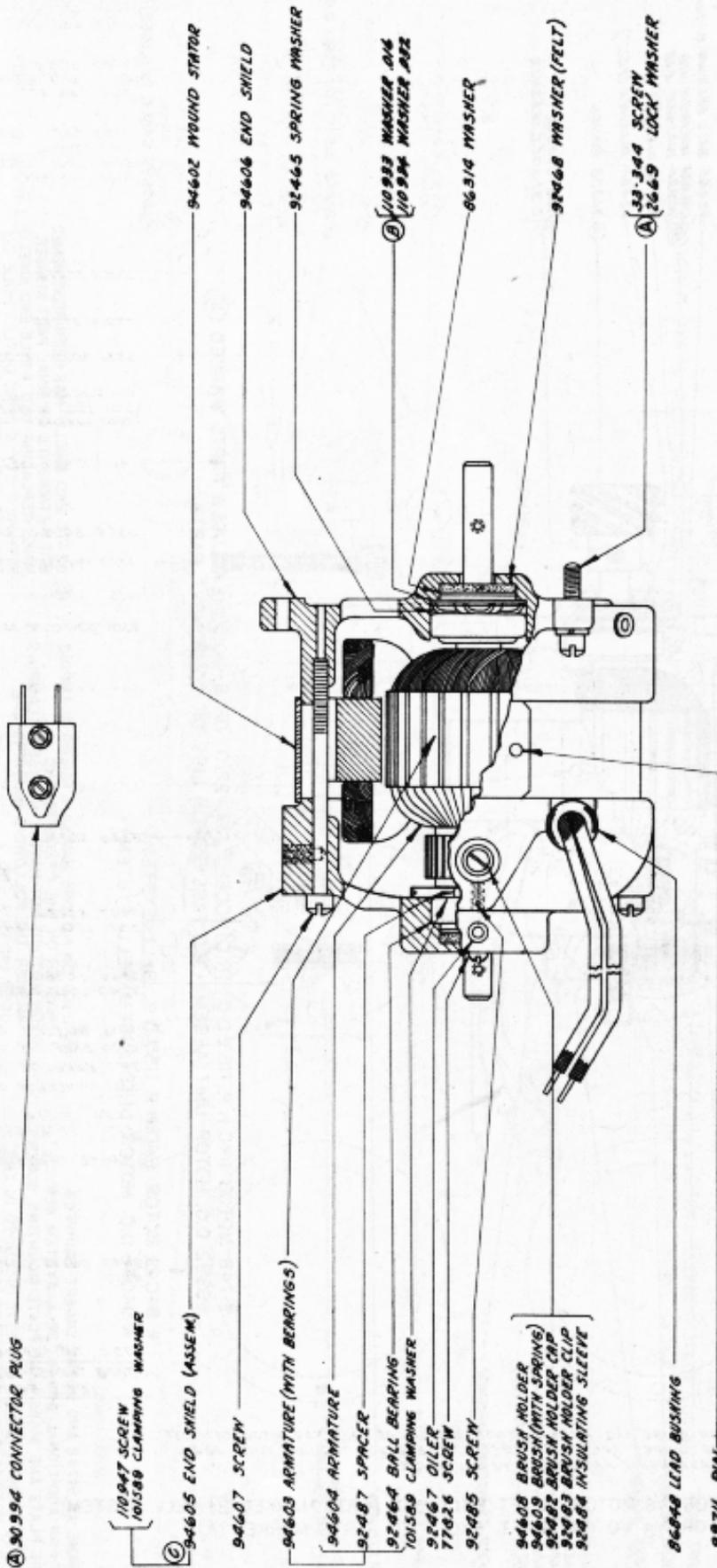

91987 MOTOR 1/40 H.P., 110V, 60 CYCLES, A.C. SERIES (H.C. MODEL #S-9016) (EXCLUDES PARTS MARKED A)
 93090 MOTOR UNIT (ASSEM) (SEE PAGE #30 FOR LIST OF COMPONENT PARTS)

* 94051 MOTOR 1/40 H.P., 110V, 60 CYCLES, A.C. SERIES (BELL SYSTEM)
 * 94045 MOTOR UNIT (ASSEM) (BELL SYSTEM)

* SAME AS 91987 AND 93090 EXCEPT EQUIPPED WITH AN ADDITIONAL 89946 "BELL SYSTEM SERVICE" NAME PLATE AND 91685 NAME PLATE MOUNTING SCREWS. 107008 TARGET (6 B 35 SPOTS) IS INCLUDED IN THE 94045 MOTOR UNIT (ASSEM)

B USED ON MOTORS HAVING A 101589 CLAMPING WASHER ON THE OPPOSITE END. ON MOTORS NOT HAVING A 101589 CLAMPING WASHER THE FOLLOWING WASHERS ARE USED ON THIS END.

- 94552 WASHER .008
- 94553 WASHER .019
- 94554 WASHER .012
- 94555 WASHER .015
- 94556 WASHER .032
- 94557 WASHER .0641

C 94605 END SHIELD - HAS BEEN REDESIGNED BUT RETAINS ITS ORIGINAL PART NUMBER. WHEN REPLACING OLD STYLE END SHIELD WITH NEW STYLE WIRE OUTLET HOLE ON EDGE OF END SHIELD THE FOLLOWING PART SHOULD BE ORDERED.

86848 LEAD BUSHING

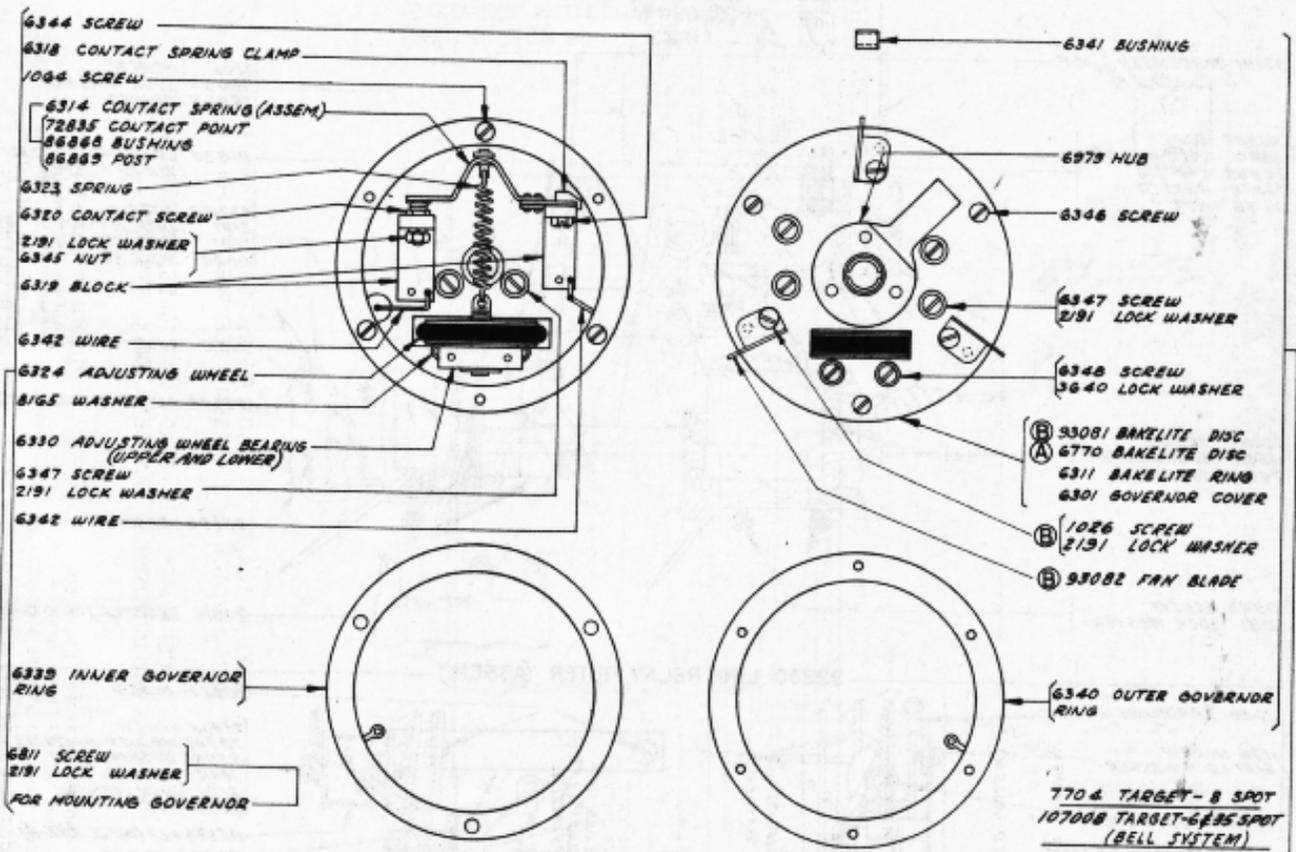
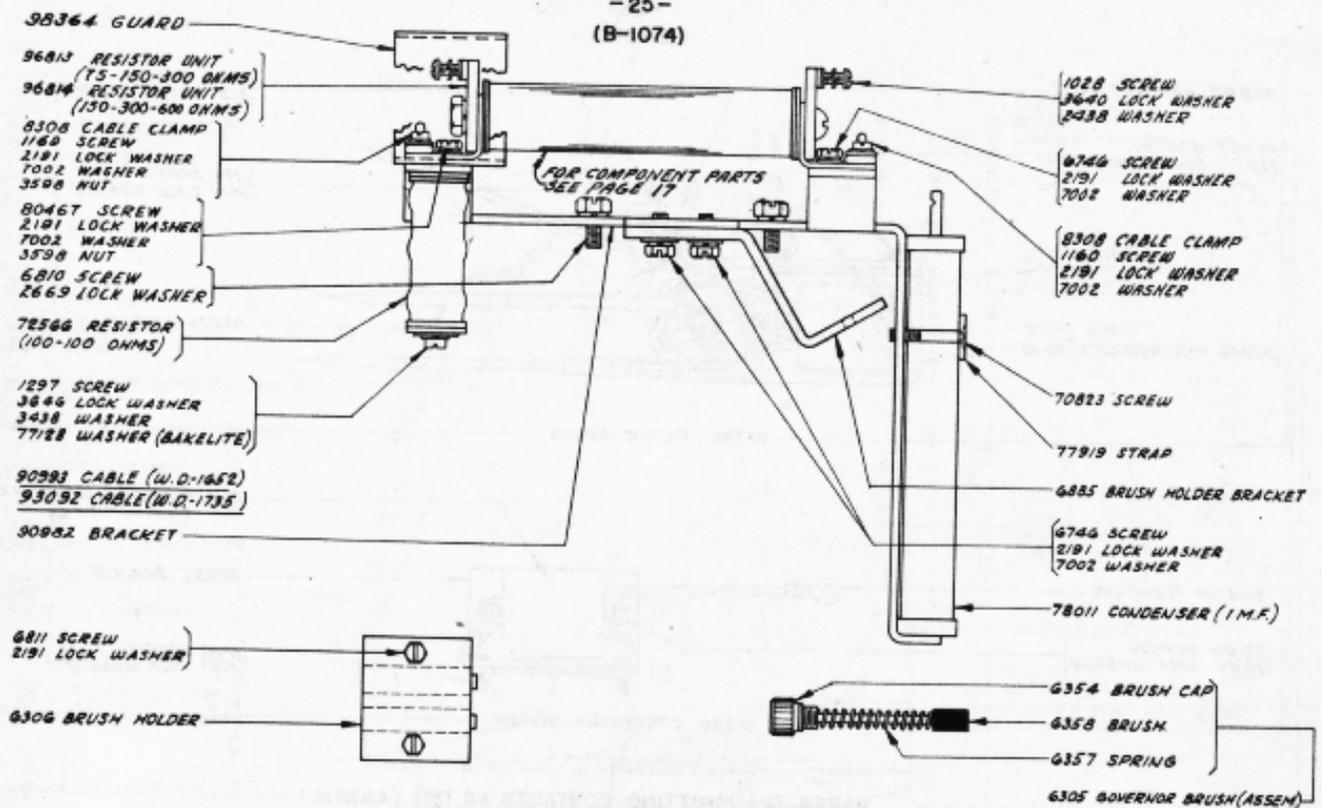

THESE GOVERNOR RINGS ARE MADE OVERSIZE, AND CAN BE USED FOR REPLACEMENT ONLY AT POINTS WHERE FACILITIES ARE AVAILABLE FOR TURNING THEM DOWN AFTER RINGS HAVE BEEN ASSEMBLED IN GOVERNOR.

7485 GOVERNOR COMPLETE FOR 3/8 MOTOR SHAFT (EXCLUDES PARTS MARKED (B) (BELL SYSTEM)
93080 GOVERNOR COMPLETE FOR 3/8 MOTOR SHAFT (EXCLUDES PARTS MARKED (A)

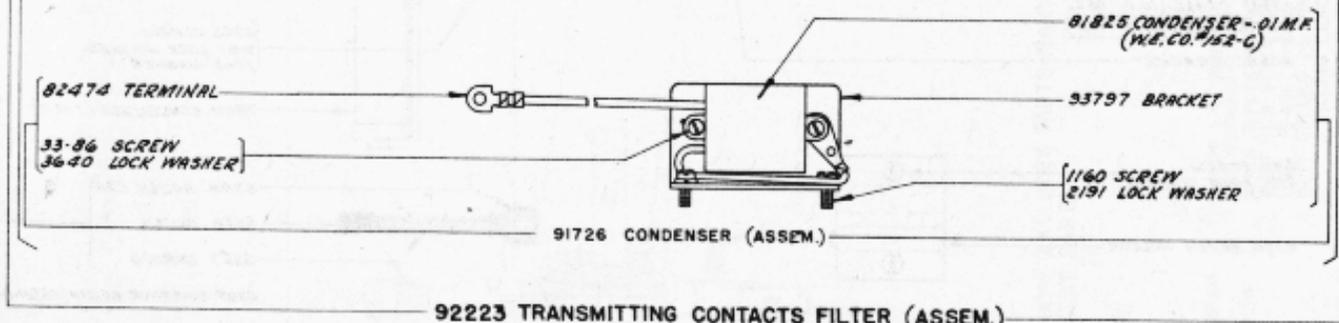
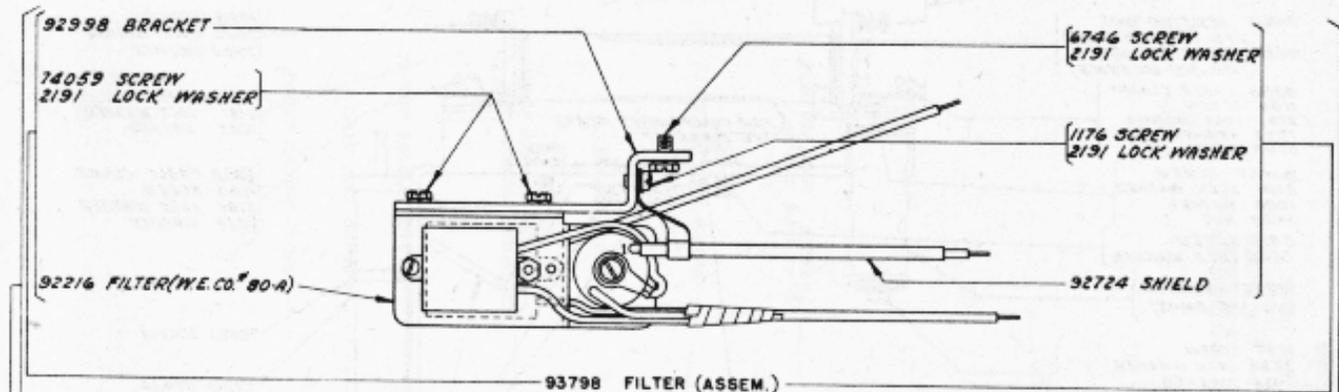

9223 TRANSMITTING CONTACTS FILTER (ASSEM.)

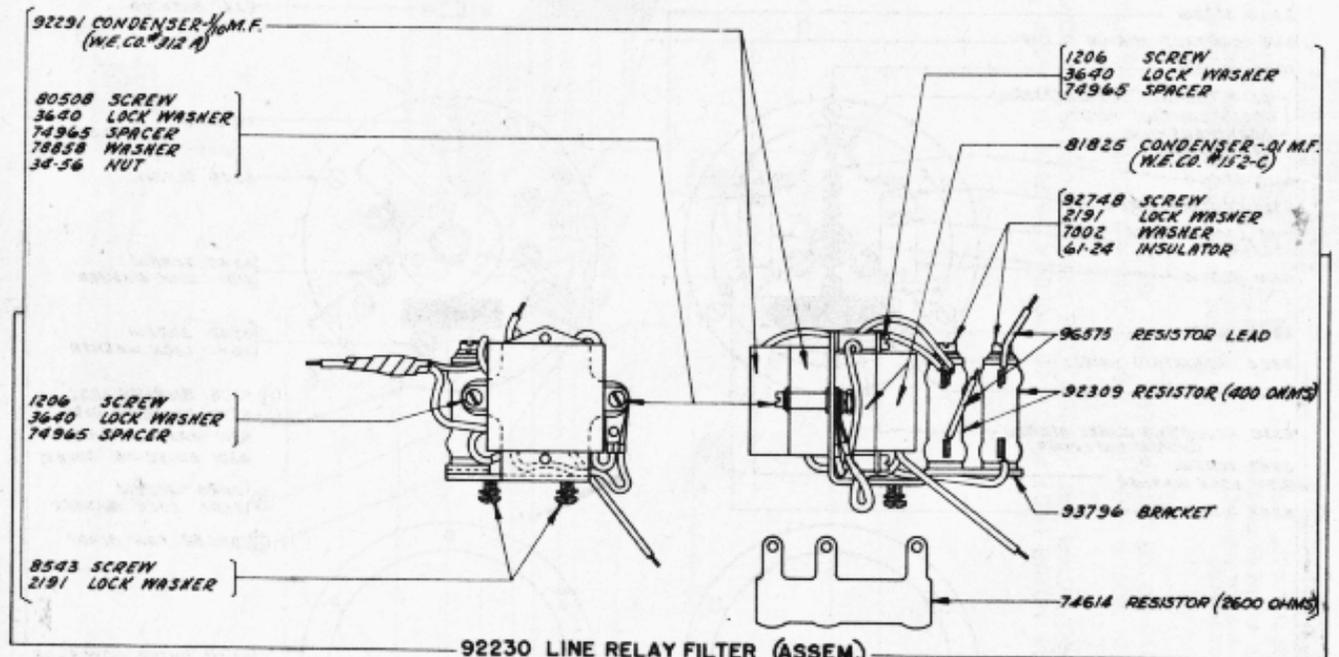

92230 LINE RELAY FILTER (ASSEM.)

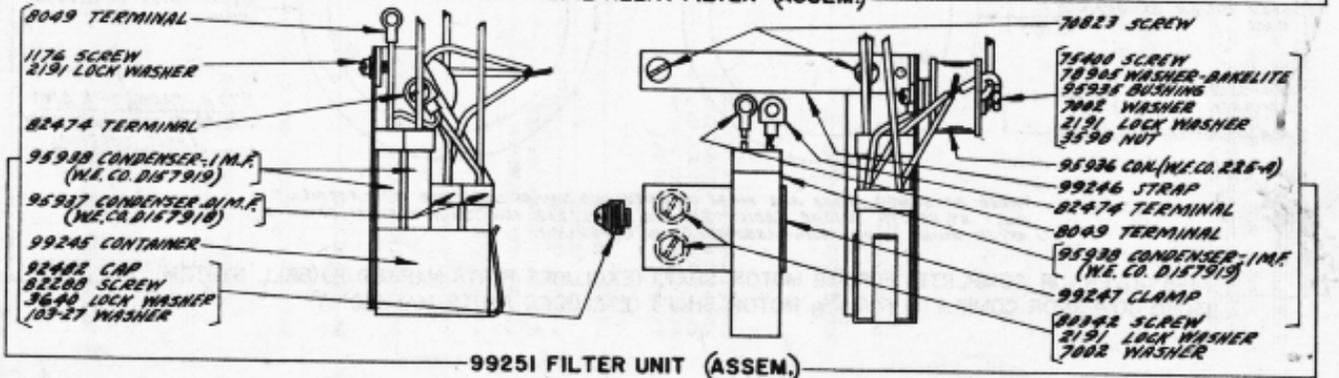

99251 FILTER UNIT (ASSEM.)

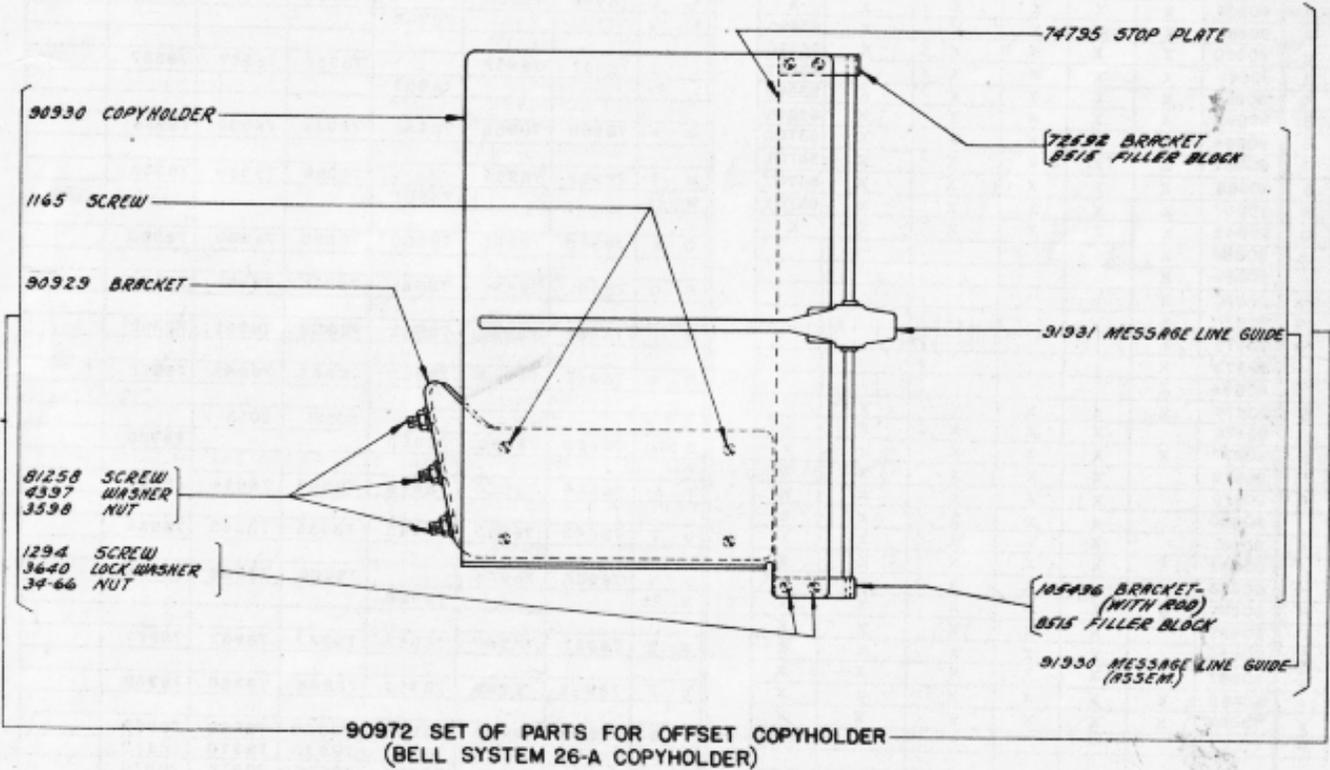
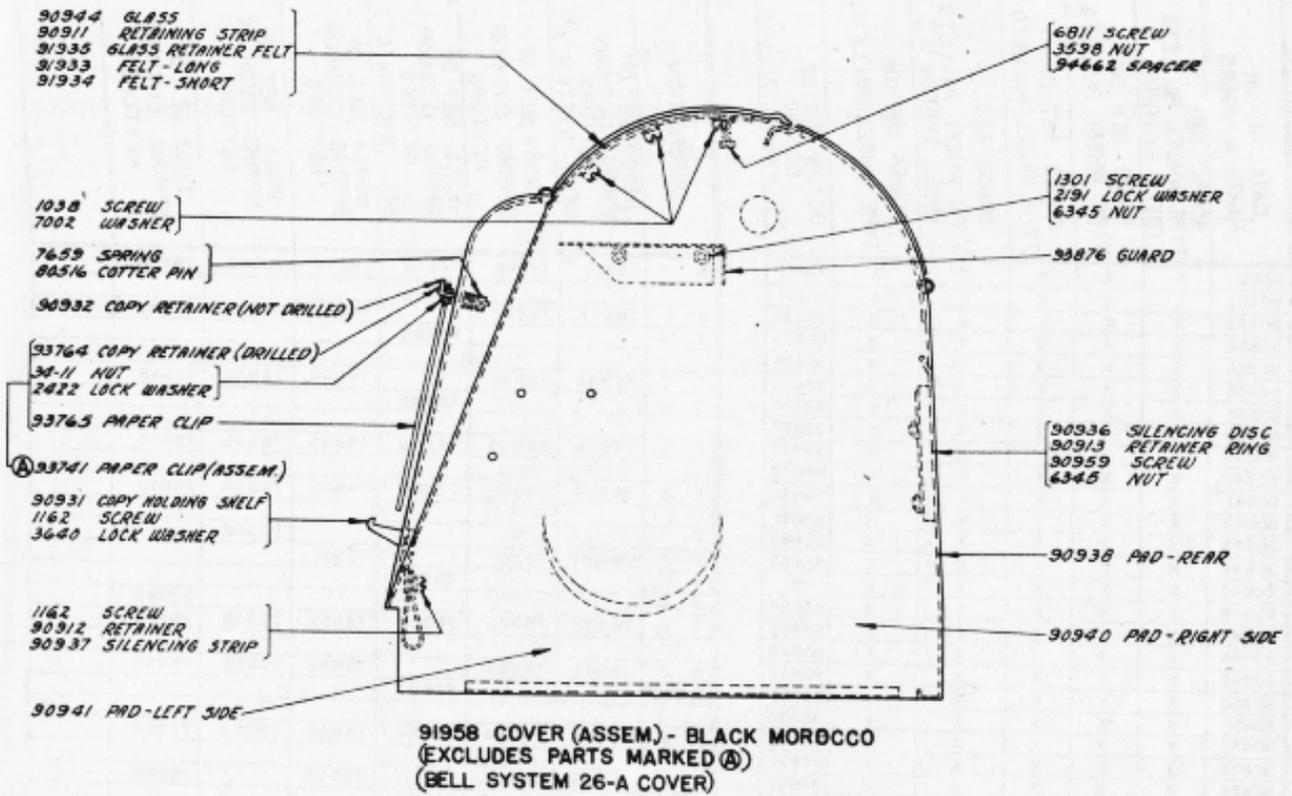

DESCRIPTION	CATALOG OR PART NUMBERS	90650 SET OF TYPE WHEEL PALLETS (BELL SYSTEM 'C')	90651 SET OF TYPE WHEEL PALLETS	90652 SET OF TYPE WHEEL PALLETS	90653 SET OF TYPE WHEEL PALLETS (BELL SYSTEM 'A')	90654 SET OF TYPE WHEEL PALLETS	93708 SET OF GOTHIC TYPE WHEEL PALLETS
A	90831	X	X	X	X	X	93670
B	90832	X	X	X	X	X	93671
C	90833	X	X	X	X	X	93672
D	90834	X	X	X	X	X	93673
E	90835	X	X	X	X	X	93674
F	90836	X	X	X	X	X	93675
G	90837	X	X	X	X	X	93676
H	90838	X	X	X	X	X	93677
I	90839	X	X	X	X	X	93678
J	90840	X	X	X	X	X	93679
K	90841	X	X	X	X	X	93680
L	90842	X	X	X	X	X	93681
M	90843	X	X	X	X	X	93682
N	90844	X	X	X	X	X	93683
O	90845	X	X	X	X	X	X
P	90846	X	X	X	X	X	93684
Q	90847	X	X	X	X	X	93685
R	90848	X	X	X	X	X	93686
S	90849	X	X	X	X	X	93687
T	90850	X	X	X	X	X	93688
U	90851	X	X	X	X	X	93689
V	90852	X	X	X	X	X	93690
W	90853	X	X	X	X	X	93691
X	90854	X	X	X	X	X	93692
Y	90855	X	X	X	X	X	93693
Z	90856	X	X	X	X	X	93694
*	90857						X
BLANK	90858	X	X	X	X	X	X
1	90859	X	X	X	X	X	93695
2	90860	X	X	X	X	X	93696
3	90861	X	X	X	X	X	93697
4	90862	X	X	X	X	X	93698
5	90863	X	X	X	X	X	93699
6	90864	X	X	X	X	X	93700
7	90865	X	X	X	X	X	93701
8	90866	X	X	X	X	X	93702
9	90867	X	X	X	X	X	93703
0	90868	X	X	X	X	X	X
1/8	90869	X					
1/4	90870	X					
3/8	90871	X					
1/2	90872	X					
3/4	90873	X					
7/8	90874	X					
\$	90875	X	X	X	X	X	X
¢	90876	X	X	X	X	X	X
@	90877	X	X	X	X	X	X
?	90878	X	X	X	X	X	X
/	90879	X	X	X	X	X	X
)	90880	X	X	X	X	X	X
(90881	X	X	X	X	X	X
/	90882	X	X	X	X	X	X
-	90883	X	X	X	X	X	X
''	90884	X	X	X	X	X	X
''	90885	X	X	X	X	X	X
''	90886	X	X	X	X	X	X
''	90887	X	X	X	X	X	X
''	90888	X	X	X	X	X	X
''	90889	X	X	X	X	X	X
#							93704

DESCRIPTION	92299 SET OF SPRING CUSHION KEYTOPS (BELL SYSTEM 'A')	78939 SET OF SPRING CUSHION KEYTOPS	92231 SET OF SPRING CUSHION KEYTOPS (BELL SYSTEM 'C')	89953 SET OF SPRING CUSHION KEYTOPS	90232 SET OF SPRING CUSHION KEYTOPS	93717 SET OF SPRING CUSHION KEYTOPS
A -	78946	78946	78946	78946	78946	78946
B ?	78947	78947		78947	78947	78947
B 5/8			78986			
C :	78948	78948		78948	78948	78948
C 1/8			78984			
D \$	78949	78949	78949	78949	78949	78949
E 3	78950	78950	78950	78950	78950	78950
F					83902	
F /	78951	78951		78951		
F 1/4			78982			
F #						93085
G &	78952	78952	78952	78952	78952	78952
H 2	78953	78953		78953	78953	78953
H STOP			82607			
I B	78954	78954	78954	78954	78954	78954
J †	78955	78955		78955		78955
J ‡			78993			
J SGL					80552	
K (78956	78956		78956	78956	78956
K 1/2			78988			
L)	78957	78957		78957	78957	78957
L 3/4			78983			
M *	78958	78958	78958	78958	78958	78958
N †	78959	78959		78959	78959	78959
N 7/8			78987			
O 9	78960	78960	78960	78960	78960	78960
P 0	78961	78961	78961	78961	78961	78961
Q 1	78962	78962	78962	78962	78962	78962
R 4	78963	78963	78963	78963	78963	78963
S †				80551	80551	
S BELL	78980	78980	78980			78980
T 5	78964	78964	78964	78964	78964	78964
U 7	78965	78965	78965	78965	78965	78965
V ;	78966	78966		78966	78966	78966
V 3/8			78985			
W 2	78967	78967	78967	78967	78967	78967
X /	78968	78968	78968	78968	78968	78968
Y 6	78969	78969	78969	78969	78969	78969
Z ††	78970	78970	78970	78970	78970	78970
CAR. RET.	78976	78976	78976	78976	78976	78976
FIGS.	78972	78972	78972	78972	78972	78972
LTRS.	78973	78973	78973	78973	78973	78973
LINE FEED	78978	78978	78978	78978	78978	78978
BLANK				78971	78971	
* *		78979				

NOTE: ALL CHARACTERS ARE MURRAY TYPE UNLESS OTHERWISE SPECIFIED

SETS OF PARTS

90420 synchronous motor unit (Assem.) consists of the following parts:

90305	Synchronous Motor 1/40 H.P., 110 V., 60 Cycle A.C.	1
33-344	Screw	3
2669	Lock Washer	3
1169	Screw	1
2191	Lock Washer	1
76484	Motor Fan	1
1179	Screw	1
2191	Lock Washer	1

90992 D.C. motor unit (Assem.) consists of the following parts:

91748	Motor 1/40 H.P. 115 V., D.C.	1
7485	Governor	1
6811	Screw	1
2191	Lock Washer	1
90982	Bracket	1
6810	Screw	1
2669	Lock Washer	2
6885	Brush Holder Bracket	2
6746	Screw	1
7002	Washer	2
2191	Lock Washer	2
6306	Brush Holder	2
6811	Screw	1
2191	Lock Washer	2
6305	Governor Brush	2
78011	Condenser (1 M.F.)	1
77919	Condenser Strap	1
70823	Screw	2
96814	Resistor Unit (150-300-600 Ohms)	1
98364	Guard	1
80467	Screw	1
3598	Nut	1
5746	Screw	1
2191	Lock Washer	1
7002	Washer	2
90993	Cable	2
90994	Connector Plug	1
72566	Resistor (100-100 Ohms)	1
1297	Screw	1
3646	Lock Washer	1
3438	Washer	1
77128	Washer	1
8308	Cable Clamp	4
1169	Screw	2
3598	Nut	1
1160	Screw	1
2191	Lock Washer	1
7002	Washer	2
33-344	Screw	2
2669	Lock Washer	3
1169	Screw	3
2191	Lock Washer	1
7704	Target - 8 Spot	1

93090 A.C. Series motor unit (Assem.) consists of the following parts:

91987	Motor A.C. Series - 115 Volts	1
93080	Governor	1
6811	Screw	1
2191	Lock Washer	1
90982	Bracket	1
6810	Screw	1
2669	Lock Washer	2
6885	Brush Holder Bracket	2
6746	Screw	1
7002	Washer	2
2191	Lock Washer	2
6306	Brush Holder	2
6811	Screw	1
2191	Lock Washer	2
6305	Governor Brush	2
78011	Condenser (1 M.F.)	1
77919	Condenser Strap	1
70823	Screw	2
96813	Resistor Unit (75-150-300 Ohms)	1
6746	Screw	1
98364	Guard	1
80467	Screw	1
3598	Nut	1
2191	Lock Washer	2

7002	Washer	2
93092	Cable	1
90994	Connector Plug	1
8308	Cable Clamp	2
1160	Screw	1
1169	Screw	1
3598	Nut	1
2191	Lock Washer	2
7002	Washer	2
33-344	Screw	3
2669	Lock Washer	3
1169	Screw	1
2191	Lock Washer	1
7704	Target - 8 Spot	1

93726 set of parts for converting a 26-A and 26-C typing unit to a 26-B and 26-D typing unit consists of the following parts:

90858	Type Wheel Pallet	(Blank)	1
90868	Type Wheel Pallet	(1/8)	1
90869	Type Wheel Pallet	(1/4)	1
90870	Type Wheel Pallet	(3/8)	1
90871	Type Wheel Pallet	(1/2)	1
90872	Type Wheel Pallet	(5/8)	1
90873	Type Wheel Pallet	(3/4)	1
90874	Type Wheel Pallet	(7/8)	1
91924	Function Arm #7-C		1
90431	Lock Washer		1
93748	Name Plate "26-B Typing Unit"		1
93750	Name Plate "26-D Typing Unit"		1
83408	Name Plate Mounting Screw		2

93727 set of parts for converting a 26-B and 26-D typing unit to a 26-A and 26-C typing unit consists of the following parts:

90876	Type Wheel Pallet	(£)	1
90878	Type Wheel Pallet	(?)	1
90879	Type Wheel Pallet	(!)	1
90880	Type Wheel Pallet	(()	1
90881	Type Wheel Pallet	())	1
90885	Type Wheel Pallet	(v)	1
90886	Type Wheel Pallet	(:)	1
90887	Type Wheel Pallet	(;)	1
90467	Function Arm #7-A		1
90431	Lock Washer		1
93747	Name Plate "26-A Typing Unit"		1
93749	Name Plate "26-C Typing Unit"		1
83408	Name Plate Mounting Screw		2

95317 set of parts to apply signal distortion prevention detent to keyboards above 240 O.P.M.

91145	Detent Lever Bracket	1
95316	Detent Lever	1
74011	Screw	1
34444	Space Collar	1
2191	Lock Washer	1
3598	Nut	1
4730	Spring	1
74986	Screw	2
2191	Lock Washer	2
7002	Washer	2

97464 set of parts for .000-.020 amp. operation:

97462	Resistor - 21,300 ohm	1
94077	Wire Lead	1
96272-R	Wire Lead	1
91517	Screw	1

98070 set of parts, upper case "H" motor control parts for 26 type printers for .060 amp. line current:

98454 set of parts to equip a typing unit with "upper case H motor control" consists of the following parts:

90611	Contact Lever	1
90615	Spring	2
90561	Pawl	1
90772	Contact Bracket (Assem.)	1
1038	Screw	2
2191	Lock Washer	2
91923	Motor Stop Function Arm #1	1
90431	Lock Washer	1
93766	Terminal Block (Assem.)	1
90895	Cable	1
83913	Contact Spring (Assem.)	1

Wiring diagram No. 1866

98455 set of parts, to equip a keyboard base with "upper case H motor control," consists of the following parts:

98071	Motor Control Bracket	1
6810	Screw	2
2669	Lock Washer	2
78011	Condenser	1
74670	Strap	1
98072	Screw	2
74992	Bushing	2
82514	Motor Control Unit (Assem.)	1
1038	Screw	2
2191	Lock Washer	2
98073	Cable	1

Wiring diagram No. 2020

105025 set of parts to provide improved lubrication of 26 printer type friction clutch:

71506	Oil Retaining Wick	1
76084	Felt Washer	1
90431	Lock Washer	1
90459	Spacer	1
96776	Friction Disc	1

110888 set of parts, leaf spring:

110853	Carriage Extension (left)	1
110728	Spring	1
110907	Screw	1
88857	Washer	1
123-244	Washer	2
87901	Screw	2
110854	Carriage Extension (right)	1
110728	Spring	1
110907	Screw	1
88857	Washer	1
123-244	Washer	2
87901	Screw	2
110855	Paper Chute Extension (left)	1
110856	Paper Chute Extension (right)	1
1035	Screw	4
103-27	Washer	4
34-56	Nut	4

110988 set of parts, leaf spring and paper chute (Assem.):

110888	Leaf Spring Set of Parts	1
102844	Paper Chute (Assem.)	1

NOTES OF EXPLANATION

Page 1

- (A) The 90302 frame has been redesigned to accommodate the new 74554 spring post for the 4704 spring. On old style 90302 frames, a 90659 spring hook, 1168 screw, and 3640 lock washer are required to anchor the spring.

Page 3

- (A) The 76172 garter spring, 76024 fulcrum disc and 76416 guide disc are used only with the old style 76414 stop pins.
- (B) The 96878 guide disc and 96879 spacer are used only with the new style 96880 stop pins.

Page 9

The 90668 bail has been redesigned but retains the same number. For old style bails, not of the one piece design, the following parts are available for replacement: 90665 wearing strip, 33-86 screws, 3640 lock washers, 90669 bail shaft, 1026 screws, 2191 lock washers.

Page 15

- (A) 90825 gear (26 teeth), shown on page 15, and 90826 intermediate gears (12 and 30 teeth), shown on page 13, are used with 7339 cam sleeve, shown on page 15, having 71838 stamped on the cams.
 - (B) 90823 gear (16 teeth), shown on page 15, and 90828 intermediate gears (7 and 30 teeth), shown on page 13, are used with 8097 cam sleeve, shown on page 15, having 71839 stamped on the cams.
 - (C) Two 41663 washers have been added under the head of each of the two 6746 screws, on the 7382 front bracket, mounting the 7387 brace.
- When it is desired to convert a non-repeating keyboard to a repeating keyboard, these washers are removed and placed under the 74749 stop plate, shown on page 13, two at each mounting screw.

NUMERICAL INDEX

M-169 Magnet, 18, 19	2449 Lock Washer, 1, 2, 7, 13, 18, 19	6770 Bakelite Disc, 25
M-207 Magnet	2502 Mounting Strip, 15	6799 Screw (6-40 x 27/32), 8
33-15 Screw (6-40 x 1/8), 18, 19	2503 Plate, 15	6801 Screw (4-40 Pilot), 8
33-42 Stud	2504 Insulator Strip, 15	6805 Screw (6-40 Shoulder), 15
33-43 Screw (6-40 x 3/4), 18, 19	2526 Spacing Collar, 15	6807 Set Screw (6-40 x 3/16), 2, 7
33-86 Screw (4-40 x 1/8), 26	2528 Spring Plate, 14	6810 Screw (10-32 x 3/8), 18, 25, 29, 31
33-110 Screw (4-40 x 3/16), 3, 7, 12	2529 Bushing, 15	6811 Screw (6-40 x 5/8), 15, 25, 27, 29
33-111 Screw (2-56 x 3/16), 10	2565 Spring, 14	6814 Screw (6-40 Pilot), 15
33-132 Screw (6-40 Shoulder), 7	2574 Upstop, 14	6827 Connecting Block (Assem.) (WE 18-B), 18
33-198 Screw (6-40 x 1/4), 13	2610 Margin Bell, 1	6883 Washer (felt), 8
33-207 Screw (8-32 x 5/16), 18	2623 Spring, 15	6885 Cam Sleeve Disc, 8
33-344 Screw (10-32 x 3/4), 16, 22, 23, 24, 29, 30	2663 Buffer, 13	6885 Brush Holder Bracket, 25, 29
34-1 Nut (1/4-32 Hex.), 13, 16	2669 Lock Washer, 1, 2, 3, 4, 8, 9, 13, 14, 16, 17, 18, 19, 22, 23, 24, 25, 29, 30, 31	6909 Stop Lever, 8
34-4 Nut (10-32 Hex.), 1, 9, 13, 14	2760 Spring, 7	6942 Screw (4-40 Eccentric), 15
34-11 Nut (1/4-56 Hex.), 2, 19, 27	2836 Spring, 10	6966 Eccentric Stop, 8
34-56 Nut (6-40 Hex.), 2, 8, 10, 15, 26	3181 Slack Bar, 11, 12	6979 Hub, 25
34-58 Nut (10-32 Hex.), 19	3298 Eccentric, 1	7001 Washer, 1, 3, 8, 18, 19
35-12 Spring, 3	3354 Nut (8-32 Hex.), 19	7002 Washer, 1, 2, 3, 4, 7, 8, 9, 10, 13, 15, 16, 17, 18, 25, 26, 27, 29, 30
35-7 Spring, 1, 9	3369 Ball, 10	7007 Trip Plunger, 8
35-89 Spring, 13	3438 Washer, 1, 13, 16, 18, 19, 25, 29	7032 Pawl, 15
35-133 Spring, 15	3458 Shim (.015), 14	7081 Post, 15
43-10 Plunger Stop, 18, 19	3595 Nut (1/4-32 Hex.), 1, 2, 7, 8, 13, 18, 19	7318 Contact Lever, 15
61-24 Washer (Fibre), 13, 26	3598 Nut (6-40 Hex.), 1, 2, 3, 4, 7, 8, 9, 10, 14, 15, 25, 26, 27, 29, 30	7339 Cam Sleeve, 15
103-27 Washer, 2, 10, 12, 20, 26, 31	3599 Nut (4-40 Hex.), 2, 3, 8, 9, 10, 13	7358 Clutch Guide, 4
123-244 Washer, 3, 8, 9, 31	3603 Nut (1/4 x 32 Hex.), 8	7372 Bearing Bracket, 15
200-1348 Washer, 10	3606 Nut (6-40 Hex.), 2, 4, 7, 8, 10, 14	7373 Bearing Bushing, 15
200-2800 Paper Spindle, 11, 12	3618 Insulator, 18, 19	7377 Lock Loop, 15
1010 Screw (6-40 Shoulder), 7	3640 Lock Washer, 1, 2, 3, 8, 9, 10, 12, 13, 15, 17, 18, 19, 20, 21, 25, 26, 27	7381 Contact Mounting (Assem.), 15
1026 Screw (6-40 x 3/8), 1, 2, 7, 8, 15, 19, 25	3642 Washer, 10	7382 Front Bracket, 15
1028 Screw (4-40 x 1/4), 10, 13, 16, 17, 18, 19, 25	3646 Lock Washer, 13, 16, 18, 19, 25, 29	7383 Oiler, 15
1030 Screw (6-40 Shoulder), 8	3647 Insulator, 18, 19	7385 Rear Bracket (with Posts), 15
1035 Screw (4-40 x 3/16), 31	3650 Washer (Brass), 13, 16, 18, 19	7386 Post, 15
1038 Screw (6-40 x 9/32), 20, 27, 30, 31	3841 Slack Bar Line, 11, 12	7387 Brace, 15
1039 Screw (6-40 Shoulder), 1, 3, 10	3899 Spacer, 18, 19	7389 Driving Clutch, 8, 15
1043 Screw (10-32 x 5/16), 13	3950 Hook, 11, 12	7391 Driven Clutch, 8, 15
1046 Screw (6-40 x 1/4), 3	4423 Shim, 7	7396 Bracket (Left), 14
1047 Screw (6-40 x 11/32), 4	4704 Spring, 1, 4	7397 Bracket (Right), 14
1050 Screw (6-40 x 7/32), 7	4708 Spring, 8	7409 Clutch Lever, 15
1064 Screw (6-32 x 1/4), 18, 25	4730 Spring, 30, A	7485 Governor Complete for 3/8 Motor Shaft (Bell System), 25, 29
1073 Screw (6-40 Thumb), 8	4810 Wick, 15	7599 Pressure Spring, 10
1118 Screw (6-40 Shoulder), 3	4871 Bolt (3/16-24 x 4), 17	7602 Spring, 8
1121 Screw (10-32 x 3/8), 1	4881 Spring Backing, 15	7603 Spring, 8, 20
1159 Screw (4-40 x 3/8), 10	5446 Screw (6-40 x 9/16), 1, 2	7607 Collar, 8
1160 Screw (6-40 x 5/16), 1, 2, 3, 8, 16, 25, 26, 29, 30	5475 Nut (8-32 Hex.), 18	7614 Spring, 8
1161 Screw (6-40 x 1/4), 2, 4, 7, 16	5988 Spindle Brake, 11, 12	7654 Shim, 15
1162 Screw (4-40 x 1/4), 2, 20, 27	6301 Governor Cover, 25	7659 Spring, 27
1163 Screw (4-40 x .188), 3	6305 Governor Brush (Assem.), 25, 29	7704 Target (8 spot), 25, 29, 30
1164 Screw (2-56 x 3/16), 11	6306 Brush Holder, 25, 29	7835 Ribbon (Black), 7
1166 Screw (4-36 x 1/4), 10, 14	6311 Bakelite Ring, 25	8049 Terminal (W.E.Co.#38), 18, 26
1169 Screw (6-40 x 7/16), 3, 20, 22, 23, 25, 29, 30	6314 Contact Spring (Assem.), 25	8097 Cam Sleeve (Bell System), 15
1174 Screw (4-40 Shoulder), 9	6318 Contact Spring Clamp, 25	8157 Selector Lever (Right), 8
1176 Screw (6-40 x 3/16), 2, 17, 26	6319 Block, 25	8158 Selector Lever (Left), 8
1179 Screw (6-40 x 5/8), 1, 22, 29	6320 Contact Screw, 25	8165 Washer, 25
1187 Screw (10-32 x 1/4), 13	6323 Spring, 25	8308 Cable Clamp, 2, 16, 25, 29, 30
1196 Screw (6-40 Shoulder), 2	6324 Adjusting Wheel, 25	8330 Washer, 1, 2, 3, 4, 9
1200 Screw (6-40 x 9/32), 10	6330 Adjusting Wheel Bearing (Upper and Lower), 25	8333 Screw (10-32 x 3/8), 16, 19
1206 Screw (4-40 x 9/16), 26	6339 Inner Governor Ring, 25	8515 Filler Block, 27
1226 Screw (6-40 x 3/4), 2	6340 Outer Governor Ring, 25	8539 Screw (6-40 x 1/2), 8, 13, 14, 21
1245 Screw (10-32 x 1), 14	6341 Bushing, 25	8543 Screw (6-40 x 1/4), 1, 4, 9, 18, 26
1268 Screw (.138-40 x 5/16), 13, 16	6342 Wire, 25	8783 Locking Lever, 13
1269 Screw (6-40 x 1/2), 3, 7, 10, 13, 14, 16	6344 Screw (6-32 x 11/32), 25	8896 Shim, 1, 3, 8, 15
1289 Screw (10-32 x 3-1/2), 18	6345 Nut (6-32 Hex.), 25, 27	9177 Contact Stop, 15
1297 Screw (6-40 x 2-7/16), 13, 16, 18, 19, 25, 29	6346 Screw (6-32 x 3/4), 25	9178 Contact Spring, 15
1301 Screw (6-32 x 3/8), 17, 27	6347 Screw (6-32 x 3/8), 25	9182 Contact Lever Shaft, 15
2034 Washer, 3	6348 Screw (4-36 x 3/4), 25	9203 Bracket (with Rollers), 14
2191 Lock Washer, 1, 2, 3, 4, 7, 8, 9, 10, 13, 14, 15, 16, 17, 18, 19, 20, 22, 23, 25, 26, 27, 29, 30, 31	6354 Brush Cap, 25	9209 Key Lever - Center, 13
2199 Nut (7/16-32 Hex.), 3, 4, 5, 15	6357 Spring, 25	9210 Key Lever - Upper, 13
2322 Lock Washer, 13, 16	6358 Brush, 25	9695 Plunger, 18, 19
2378 Spacer Key Lever, 13	6390 Screw (.138-40 x 3/16), 3, 4	22015 Spring, 2
2382 Lock Washer, 1, 19	6685 Sword, 8	34432 Washer, 1, 2, 4, 8, 9, 13, 16
2407 Lock Washer, 15	6689 Separator Plate, 8	34444 Space Collar, 30
2422 Lock Washer, 11, 27	6745 Screw (10-32 x 1/2), 1, 3, 4, 18, 19	34464 Spring, 1, 2
2438 Washer, 17, 25	6746 Screw (6-40 x 5/16), 1, 2, 4, 8, 10, 13, 14, 15, 17, 26, 25, 29	35826 Washer, 1
		36273 Washer, 13, 15
		41663 Washer, 15
		41720 Contact Spring, 20, 21
		41732 Plate, 20
		41733 Insulator, 20, 21

NUMERICAL INDEX

41746	Bushing - Bakelite, 21	74722	Washer, 7, 8	78947	Spring Cushion Keytops
41830	Contact Spring, 20	74727	Terminal, 21	78948	(B ?), 28
43954	Gong, 1	74728	Terminal, 20	78948	(C), 28
44035	Screw (10-32 x 9/16), 1	74749	Stop Plate, 13	78949	(D #), 28
44048	Washer, 19	74751	Trip-off Lever, 13	78950	(E 3), 28
46092	Nut (10-32 Hex.), 1	74762	Key Lever - Lower, 13	78951	(F 1), 28
47024	Lock Washer, 10	74795	Stop Plate, 27	78952	(G &), 28
49056	Screw (10-32 x 7/8), 8	74808	Bushing, 13	78953	(H &), 28
55090	Spring, 4	74821	Resistor (2810 ohm), 18	78954	(I 8), 28
55297	Screw - Flat Head, 22	74852	Cord (with terminals), 18 (approx. 20" long)	78955	(J), 28
55335	Screw (8-32 x 5/16), 19	74853	Power Cord (Assem.), 18	78956	(K (), 28
55669	Spring, 7	74882	Spring, 9	78957	(L), 28
70177	Screw (6-40 Pilot), 14	74891	Shim, 15	78958	(M), 28
70388	Spring, 9	74892	Shim, 13	78959	(N), 28
70324	Lockout Lever Bearing, 13	74952	Screw (4-40 x 5/8), 20	78960	(O 9), 28
70529	Stiffener, 20	74964	Contact Spring, 20	78961	(P 0), 28
70724	Insulation Strip, 17	74965	Bushing, 20, 26	78962	(Q 1), 28
70803	Screw (6-40 Pivot), 20	74986	Screw (6-40 x 13/32), 2, 3, 10, 30	78963	(R 4), 28
70823	Screw (6-32 x 1), 25, 26, 29	74992	Bushing, 31	78964	(T 5), 28
70886	Washer, 8	75220	Terminal (W.E.Co. #47), 18	78965	(U 7), 28
70887	Nut (3/16-24 Hex.), 17	75231	Bushing, 18, 19	78966	(V), 28
71047	Shim, 3, 18, 19	75400	Screw (6-40 x 1), 26	78967	(W 2), 28
71073	Washer, 8	75436	Resistor (3000 ohm), 18	78968	(X /), 28
71161	Bushing, 15	75606	Spring, 15	78969	(Y 6), 28
71449	Key Lever Guide (Rear), 14	75607	Washer, 15	78970	(Z), 28
71506	Oil Wick, 3, 31	75750	Washer - Bakelite, 3, 16, 18	78971	(Blank), 28
71647	Shim, 1	76008	Stud, 3	78972	(FIGS), 28
71681	Ribbon Spool, 7	76011	Code Disc #1, 3	78973	(LTRS), 28
71697	Clamping Plate, 8	76012	Code Disc #2, 3	78976	(CAR RET), 28
71976	Stop Lever Plate, 8	76013	Code Disc #3, 3	78978	(LINE FREQ), 28
72472	Shim, 13	76014	Code Disc #4, 3	78979	(.), 28
72481	Plug, 18, 19	76015	Code Disc #5, 3	78980	(S BELL), 28
72501	Shaft, 13	76016	Bushing, 3	78982	(F 1/4), 28
72508	Screw (6-40 x 3/4), 7	76024	Fulcrum Disc (2-11/16" Diam.), 3	78983	(L 3/4), 28
72513	Driving Disc, 8	76081	Washer, 13	78984	(C 1/8), 28
72514	Spring, 8	76084	Washer (felt), 3, 31	78985	(V 3/8), 28
119541-72515	Nut (5/16 x 32 L.H. Hex.), 8	76086	Friction Spring, 3	78986	(B 5/8), 28
72516	Retaining Disc, 8	76099	Washer, 2, 3, 4	78987	(N 7/8), 28
119540-72517	Nut (5/16 x 32 L.H. Hex. Keyed), 8	76117	Terminal Block (Assem.), 18, 19	78988	(K 1/2), 28
72521	Wick, 3, 8	76118	Terminal Block, 18, 19	78993	(J), 28
72563	Washer (felt), 8	76168	Screw (6-40 x 3/16), 4	79449	Shim, 9
72566	Resistor (100-100 ohms), 25, 29	76172	Garter Spring, 3	79513	Plate, 18, 19
72592	Bracket, 27	76303	Shim, 3	80084	Contact Spring, 20
72643	Stud, 13	76395	Friction Washer, 3	80294	Spring Post, 1, 2
72728	Receptacle, 19	76396	Washer (felt), 3	80342	Screw (6-40 x 23/64), 2, 9, 26
72835	Contact Point, 25	76414	Stop Pin (Looped Lower End), 3	80392	Spring, 14
73181	Break Key (Plain), 13	76416	Guide Disc - Lower (3-1/16" Diam.), 3	80444	Screw (6-40 x 1/4), 3, 4, 8, 10, 18, 19
73357	Terminal End (Assem.), 17	76461	Washer, 1	80467	Screw (6-40 x 3/8), 1, 25, 29
73497	Plug, 18	76484	Motor Fan, 22, 29	80471	Clutch Spring, 15
73588	Contact Spring, 18	76556	Stop Arm (Assem.), 3	80508	Screw (4-40 x 25/32), 20, 26
73592	Spring Plate, 18, 19	76559	Typewheel Latch Spring, 3	80516	Cotter Pin, 27
73593	Contact Spring, 18, 19	76806	Spring, 10	80708	Cable Clamp, 16
73705	Terminal Block, 2, 13, 16, 20	77040	Contact Spring, 20	80721	Washer, 8
74011	Screw (6-40 Shoulder), 30	77128	Washer (Bakelite), 13, 16, 19, 25	80832	Contact Bracket, 21
74018	Piston Rod, 1	77826	Nut (9/16-32 Hex.), 3	80833	Guard (Bakelite), 21
74027	Vent Screw, 1	77919	Screw (6-32 x 3/4), 23, 24	81584	Bracket, 17
74028	Cylinder, 1	77920	Strap, 25, 29	81824	Nut, (4-40), 10
74029	Piston Head, 1	78011	Screw (6-40 x 1-15/16), 3, 13	81825	Condenser .01 M.F. (W.E. Co. #152-C), 26
74032	Washer, 1	78028	Condenser (1 M.F.), 25, 29, 31	81836	Washer - Bakelite, 13, 16
74033	Washer (Leather), 1	78163	Screw (6-40 x 15/16), 3, 8	81841	Condenser (1/4 M.F.) (W.E. 142-B), 18
74059	Screw (6-40 x 7/32), 26	78172	Post, 8	81895	Post, 7
74142	Cylinder Head, 1	78172	Selector Post, 8	82288	Screw (4-40 x 1/4), 26
74334	Washer, 7	78205	Spring, 7	82440	Screw (6-40 x 7/16), 1, 8, 13
74399	Pilot Screw, 8	78301	Resistor - 300 Ohms, 17	82444	Bushing, 20
74523	Space Bar, 13	78301	Screw (10-32 x 5/8), 1	82474	Terminal, 19, 26
74528	Spacer Bar Loop, 13	78430	Cable Clamp, 13	82514	Motor Control Unit (Assem.), 31
74536	Set Screw (6-40 x 5/32), 10	78596	Washer, 8	82515	Connecting Block, 18
74554	Spring Post, 1	78597	Screw (10-32 Shoulder), 8	82516	Contact Spring, 18
74581	Selector Bar No. 1 (Rear), 14	78723	Eccentric, 1	82559	Bushing, 20
74582	Selector Bar No. 2, 14	78858	Washer, 26	83355	Washer (Bakelite), 18
74583	Selector Bar No. 3, 14	78905	Washer - Bakelite, 26	83408	Screw (4-40 x 3/16), 4, 13, 30
74584	Selector Bar No. 4, 14	78939	Set of Spring Cushion Key tops, 28	83856	Screw (4-40 x 11/16), 20
74585	Selector Bar No. 5 (Front) 14	78939	Set of Spring Cushion Key tops, 28	83913	Contact Spring, 20, 30
74604	Repeat Space Rod, 13	78939	Set of Spring Cushion Key tops, 28	84990	Screw (6-40 x 1/4), 3
74605	Bracket, 13	78939	Set of Spring Cushion Key tops, 28	85252	Screw (10-32 Shoulder), 17
74613	Screw (4-40 x 1/4), 2	78939	Set of Spring Cushion Key tops, 28	85936	Post, 18
74614	Resistor (2000-600 ohm), 18, 26	78939	Set of Spring Cushion Key tops, 28	85937	Insulator, 18
74670	Strap, 31	78939	Set of Spring Cushion Key tops, 28	85957	Washer, 2
74702	Spring, 9	78939	Set of Spring Cushion Key tops, 28	86216	Screw (4-40 Shoulder), 20
74709	Spring, 4	78939	Set of Spring Cushion Key tops, 28	86314	Washer, 22, 23, 24
74717	Screw (4-40 x 23/64), 21	78939	Set of Spring Cushion Key tops, 28	86325	Switch (with 86326 Springs), 22
		78946	Spring Cushion Keytops (A -), 28	86327	Bushing (Fibre), 22

NUMERICAL INDEX

86329	Screw (4-40 x 7/16), 22	90436	Oil Wick, 13	90611	Contact Operating Lever, 20, 30
86506	Post, 2	90437	Wick, 2	90612	Bell Operating Lever, 9
86710	Oil Cup, 8	90438	Oil Ring, 15	90613	Line Feed Bail Operating Lever, 9
86774	Screw (4-40 Shoulder), 2	90439	Screw (1-64 x .175), 7	90614	Function Pawl latch, 9
86848	Lead Bushing, 22, 23, 24	90441	Garter Spring, 7	90615	Spring, 2, 9, 20, 30
86869	Post, 25	90442	Post, 7	90617	Pawl, 9
86868	Bushing, 25	90457	Sleeve, 3	90618	Plate, 9
87636	Screw (2-56 x 3/16), 19	90458	Disc (with Hub), 5	90621	Bushing, 9
87901	Screw (2-56 x 1/8), 31	90459	Spacer, 3, 5, 31	90622	Stud, 9
87932	Nut (8-32 Hex.), 18	90461	Function Arm, 6	90623	Latch, 9
87933	Washer, 18	90462	Function Arm, 6	90624	Unlatch Pawl, 9
88455	Washer, 17	90463	Function Arm, 6	90628	Screw (6-40 Shoulder), 1
88857	Washer, 31	90464	Function Arm, 6	90629	Gong Hammer, 9
88924	Rubber Foot, 17	90465	Function Arm, 6	90633	Insulator, 20
88925	Rubber Foot Cup, 17	90466	Function Arm, 6	90635	Cut-out Lever, 9
89317	Line Cord (Assem.), 18	90467	Function Arm #7-A, 6, 30	90636	Cut-out Lever, 9
89354	Cable Clamp, 13, 16	90468	Function Arm, 6	90637	Function Lever, 9
89467	Cord (with terminals) (approx. 43-5/8 Long), 18	90469	Function Arm, 6	90639	Bracket, 20
89468	Plug, 18	90470	Function Arm, 6	90640	Spacer Shaft (with Gear), 1
89469	Power Cord (Assem.), 18	90472	Function Arm, 6	90643	Spacing Ratchet, 1
89548	Contact Spring (W.E. 149618), 18	90473	Function Arm, 6	90644	Upper Bearing, 1
89861	Cord (with terminals) (approx. 35" Long), 18	90474	Spacer, 3, 6	90645	Lower Track, 1
89896	Oiler, 15	90475	Gear (40-T, 368 O.P.M.), 22, 23	90647	Upper Track, 1
89897	Lock Nut, 15	90480	Nut (9/16-32 Capstan), 3	90650	Set of Type Wheel Pallets (Bell System "C"), 28
89917	Screw (4-40 Eccentric), 15	90490	Shims, 8	90651	Set of Type Wheel Pallets, 28
89925	Terminal End, 17	90491	Bushing, 8	90652	Set of Type Wheel Pallets, 28
89946	Name Plate, 4, 22, 23, 24	90499	Bushing, 8	90653	Set of Type Wheel Pallets (Bell System "A"), 28
89953	Set of Spring Cushion Keytops, 28	90500	Selector Plate, 7, 8	90654	Set of Type Wheel Pallets, 28
90043	Armature Bracket, 8	90505	Locking Lever, 8	90657	Buffer Lever, 1
90069	Detent Post, 8	90507	Separator Top Plate, 8	90658	Screw (10-32 Shoulder), 1
90117	Screw (6-40 Shoulder), 7	90508	Spring Arm, 8	90660	Trip Rod, 1
90232	Set of Spring Cushion Keytops, 28	90509	Detent, 8	90662	Bell Hammer (Assem.), 1
90260	Spring, 15	90510	Spring, 8	90667	Gong Bracket, 1
90265	Screw (6-40 Special), 8	90511	Screw (6-40 x .820), 8	90668	Bail, 9
90302	Frame, 1	90512	Selector Arm Bracket, 8	90670	Screw (10-32 Pivot), 1
90303	Locating Pin, 2	90513	Eccentric, 8	90671	Carriage Frame, 10
90305	Synchronous Motor (1/40 H.P., 110 V., 60 cycle, AC., H.C. Model #RBS-4416 or S-9014), 22, 29	90514	Screw (3/16-40 Pivot), 8	90679	Oil Ring, 1, 3
90307	Stop Plate, 2	90515	Screw (3/16-40 Pivot), 8	90682	Carriage Stop, 10
90308	Pinion, 22, 23	90516	Selector Arm, 8	90683	Rack, 10
90326	Oil Wick, 3	90517	Spring, 8	90684	Spacer, 10
90328	Tube (inner), 3	90518	Locking Wedge, 8	90685	Line Feed Shaft, 10
90329	Tube (outer), 3	90519	Screw (2-56 x .156), 8	90686	L.F. Roller Arm, 10
90330	Post, 3	90520	Armature Lever, 8	90691	L.F. Pawl Arm, 10
90331	Separator, 3	90524	Screw (4-40 Special), 8	90697	Screw (10-32 Pivot), 1
90332	Roller, 3	90526	Screw (10-32 x 1-1/8), 1	90698	Eccentric, 10
90333	Code Disc Lever, 3	90530	Transfer Lever, 8	90699	L.F. Bracket, 1
90334	Bushing, 3	90532	Function Bracket, 2	90700	Detent, 10
90335	Separator, 3	90535	Oil Ring, 2, 4, 9	90707	Spacer, 10
90336	Stud, 3	90538	Lever, 2	90708	Screw (4-40 Shoulder), 10
90337	Plate, 3	90539	Shoulder Bushing, 2	90709	Pressure Release Shaft, 10
90338	Stud, 3	90542	Follow Arm, 2	90710	Pressure Release Arm, 10
90350	Bushing, 3	90546	Cam Roller Stud, 2	90713	Pressure Release Handle, 10
90371	Type Pallet Guide, 7	90547	Roller, 2	90714	Spacer, 10
90373	Washer, 7	90549	Bail, 2	90720	Platen, 10
90376	Bail Retainer, 10	90551	Space Arm Bail, 2	90725	Ratchet, 10
90379	Universal Bar, 14	90556	Roller, 2, 7	90726	Platen Shaft, 10
90380	Spring Drum (Assem.), 1	90559	Screw (4-40 x 1.588), 2	90728	Paper Guide, 10
90381	Drum, 1	90560	Washer, 2	90731	Margin Bell Adjuster, 10
90384	Resistor (1050 Ohm), 13, 16, 19	90561	Function Pawl #1, 2, 20, 30	90733	Bushing, 7
90385	Drum Shaft, 1	90562	Line Feed Pawl, 2	90737	Detent Spring, 7
90389	Spring, 1	90563	Unshift Pawl, 2	90738	Ribbon Feed Pawl, 7
90390	Cover, 1	90564	Shift Pawl, 2	90740	Stud, 7
90391	Oil Ring, 1	90565	Spacer, 2	90741	Operating Lever, 7
90392	Paper Chute, 11	90566	Shoulder Bushing, 2	90742	Clamp Plate, 7
90393	Paper Chute, 11	90567	Space Pawl, 2	90743	Bushing, 7
90395	Rod, 11	90570	Plunger, 2	90744	Check Pawl, 7
90396	Rod, 11	90571	Compression Spring, 2	90747	Screw (4-40 Shoulder), 7
90398	Shaft, 8	90573	Space Pawl Spring, 2	90748	Spring, 7
90399	Bearing, 8	90581	Set Collar, 2	90749	Shim, 10
90401	Line Feed Control, 10	90582	Yield Spring, 2	90750	Shaft, 7
90420	Synchronous Motor Unit (Assem.), 22, 29	90583	Spring Retainer, 2	90752	Washer (felt), 7
90421	Spacer, 2	90584	Transfer Arm Lock, 2	90753	Ratchet (right), 7
90422	Terminal, 2, 20	90588	Ribbon Feed Arm, 2	90754	Ratchet (left), 7
90424	Swivel, 9	90589	Drive Link, 2	90755	Friction Spring, 7
90425	Screw (10-32 x 1-1/8), 9	90590	Lever Plate, 9	90756	Extension, 7
90426	Nut (10-32 Special), 9	90595	Spring Post, 9	90759	Armature Bracket Link, 8
90431	Lock Washer, 3, 5, 20, 30, 31	90596	Stud, 9	90764	Ribbon Reverse Lever, 7
90433	Shaft, 2	90597	Bushing, 9	90765	Basket, 10
90435	Bushing, 2	90598	Bushing, 2, 9	90767	Roller, 10

NUMERICAL INDEX

90770	Roller Bearing, 10				
90771	Latch, 9	90879	Type Wheel Pallets	90991	Retaining Wire (.062), 10
90772	Contact Bracket (Assem.),	90880	(1), 28, 30	90992	D.C. Motor Unit (Assem.), 29
	20, 30	90881	(2), 28, 30	90993	Cable (W.D. 1652), 2, 25, 29
90774	Bell Crank, 8	90882	(3), 28, 30	90994	Connector Plug, 22, 23, 24, 29, 30
90775	Range Scale, 8	90883	(4), 28	91120	Spring, 8
90778	Platen Handle Shaft, 10	90884	(5), 28	91145	Detent Lever Bracket, 30
90779	Sleeve, 10	90885	(6), 28, 30	91517	Screw, 30
90780	Screw (3/8-32 Thumb), 10	90886	(7), 28, 30	91685	Screw (4-48 x 1/8), 4, 22, 23, 24
90781	Release Latch, 10	90887	(8), 28, 30	91721	Screw (10-32 x 3-7/8), 13, 16
90786	Platen Clamp, 10	90888	(9), 28, 30	91722	Set of Stop Contact Parts, 20
90789	Washer, 9	90889	(10), 28	91724	Stop Contact (Assem.), 20
90791	Lock Washer, 2, 8	90891	Spring, 9	91748	Motor (1/4 H.P., 115 V.
90796	Paper Spindle (Includes	90892	Spring, 9		D.C.), 29
	74877 Spring), 11, 12	90893	Post, 7	91787	Resistor (8000 Ohms), 18
90797	Power Cable (W.D. 1725)	90894	Cable (W.D. 1734), 2	91861	Bushing, 19
	(Bell System), 13	90895	Cable, 20, 30	91900	Cover - Right, 17
90802	Keyboard Base, 13	90898	Draw Strap, 1	91901	Cover - Left, 17
90803	Key Lever Guide, 13	90900	Connector, 14, 16	91905	Ratchet, 10
90804	Bracket, 14	90904	Spring, 4, 8	91908	Small Paper Roll Holder
90805	Key Lever Shaft, 14	90905	Post, 8		(8-1/2") (Includes 90395,
90806	Shaft Support, 14	90906	Nut (1/4-32 Thumb), 13, 16	91909	1164, and 2422), 11
90807	Spacer Bar Shaft, 13, 14	90909	Cable Clamp, 14, 16		Transmitter Distributor
90808	Shaft, 15	90911	Retaining Strip, 27	91911	Control Contacts, 20
90811	Stud, 13	90912	Retainer, 27		Remote Signal Bell Contact,
90814	Resistor (1000 Ohms), 13	90913	Retainer Ring, 27	91912	20
90815	Resistor (5000 Ohms), 3	90914	Screw (6-40 Shoulder), 2, 7		Power Cable - W.D. 1646 and
90818	Washer, 13	90915	Name Plate (Teletypewriter	91913	W.D. 1752 (Bell System), 16
90819	Oil Ring, 2, 13		Service), 4	91914	Line Cable (W.D. 1646), 13
90823	Gear (16 Teeth) (Bell	90916	Stop Post, 9	91923	Function Arm, 6
	System), 15	90917	Crank Handle, 10	91924	Function Arm #2-1, 6, 20,
90825	Gear (26 Teeth), 15	90918	Washer (Rubber), 10	91926	Function Arm #7-C, 6, 30
90826	Gears (12 and 30 Teeth), 13	90919	Platen Handle Bracket, 1	91927	Escapement Lever, 1
90828	Gears (7 and 3 Teeth), 13	90925	Screw (4-40 x 3/16), 13, 16	91929	Selector Cover, 3
90830	Spacer, 2	90926	Toggle Switch, 13, 16	91929	Spring Drum Stop, 1
		90927	Spacer Plate, 16	91930	Message Line Guide (Assem.),
		90931	Copy Holding Shelf, 27		27
		90932	Copy Retainer (Not	91931	Message Line Guide, 27
			Drilled), 27	91933	Felt - Long, 27
				91934	Felt - Short, 27
		90935	Stud, 17	91935	Glass Retainer Felt, 27
		90936	Silencing Disc, 27	91941	Shim, 3
		90937	Silencing Strap, 27	91943	Strap, 14, 16
		90938	Pad - Rear, 27	91951	Pin, 11
		90940	Pad - Right Side, 27	91952	Line Cable - W.D. 1668
		90941	Pad - Left Side, 27		(Bell System), 16
		90942	Paper Roll Bracket, 11	91953	Wedge, 2
		90944	Glass, 27	91956	Detent, 10
		90945	Base Plate (Assem.), 17	91958	Cover (Assem.), 27
		90946	Base Plate, 17	91960	Line Relay Mounting (Assem.)
		90947	Silencing Strip, 14		18
		90948	Clamp Plate (Long), 14	91987	Motor (1/40 H.P., 110 V.,
		90949	Clamp Plate (Short), 14		60 Cycle, A.C. Series)
		90951	Lock Washer, 2		(H.C. Model #8-9016),
		90952	Screw (1/4-20 Shoulder), 17		24, 29
		90953	Screw (3-48 x 5/16), 13, 16	92216	Filter (W.E. Co. #80-A), 26
		90958	Base - Receiving Only, 16	92231	Set of Spring Cushion Key
		90959	Screw (6-40 x 5/16), 27		Tops (Bell System "C"), 28
		90960	Bracket, 18	92291	Condenser (1/10 M.F.)
		90961	Spacer, 18		(W.E. 3124), 13, 26
		90964	Line Relay Mounting (Assem.)	92299	Set of Spring Cushion Key
			(Bell System), 18		Tops (Bell System "A"), 28
		90965	Name Plate, 16	92309	Resistor (400 Ohms), 26
		90966	Line Cable - W.D. 1646, 16	92456	Wound Stator, 22
		90967	Cable (W.D. 1687), 18	92457	Motor Lead, 22
		90968	Set of Paper Bracket Parts	92458	End Shield (Assem.), 22
			(8-1/2"), 11	92459	End Shield, 22
		90969	Paper Chute (Assem.)	92460	Split Ring, 22
			(8-1/2"), 11	92461	Washer, 22
		90970	Paper Chute (Assem.)	92462	Screw (6-32 x 1), 22
			(8"), 11	92463	Screw (10-32 x 4), 22
		90971	Set of Paper Bracket Parts	92464	Ball Bearing, 22, 23, 24
			(8"), 11	92465	Ball Bearing Spring, 22, 23, 24
		90973	Paper Finger, 10	92467	Oiler, 22, 23, 24
		90977	Contact Lever Latch, 20	92468	Washer (Felt), 22, 23, 24
		90978	Latch Bracket, 20	92469	Rotor (Assem.), 22
		90979	Latch Release Lever, 20	92470	Cupped Washer, 22
		90981	Control Relay (Assem.), 18	92471	Lock Washer, 22
		90982	Bracket, 25, 29	92476	End Shield (Assem.), 23
		90983	Line Cable (W.D. 1641), 18	92477	End Shield, 23
		90984	Power Cable (W.D. 1641), 18	92478	Screw (10-32 x 3), 23
		90986	Terminal Bracket (with Name	92479	Coil Retaining Pin, 23
			Plate), 18	92480	Brush Holder, 23
		90987	Relay Bracket, 18, 19	92481	Brush (with Spring), 23
		90989	Set of Parts for Break-Lock	92482	Brush Holder Cap, 23, 24, 26
			Mechanism, 20	92483	Brush Holder Clip, 23, 24

NUMERICAL INDEX

92484	Insulating Sleeve, 23, 24	92735	Screw (6-40 Special), 2	93708	Set of Gothic Type Wheel Pallets, 28
92485	Screw (10-32 x 3/16), 23, 24	92736	Post, 4	93717	Set of Spring Cushion Keytops, 28
92486	Armature, 23	92737	Washer, 4	93722	Strap, 17
92487	Spacer, 23, 24	92739	Retainer, 8	93723	Carrying Handle, 17
92511	Roller, 15	92748	Screw (6-40 x 1-7/16), 26	93724	Set of Carrying Handle Parts, 17
92603	Shift Bail, 4	92809	Gear (60 T) 368 OPM, 22, 23	93725	Set of Stop Contact Parts, 20
92604	Roller Bracket, 4	92811	Shim, 2	93726	Set of Parts for Converting a 26-A and 26-C Typing Unit to a 26-B and 26-D Typing Unit, 30
92605	Stud, 4	92825	Guard, 4	93727	Set of Parts for Converting a 26-B and 26-D Typing Unit to a 26-A and 26-C Typing Unit, 30
92606	Roller, 4	92826	Screw (10-32 x 5/8), 2	93729	Wick, 4
92609	Shaft, 4	92856	Resistor (800-400-200-100 Ohms), 13, 16, 18	93734	Cable (W.D.-1642), 18
92610	Bushing, 4	92899	Clamp, 2	93737	Shim (.004), 14
92611	Shaft, 4	92907	Stop Plate, 7	93741	Paper Clip (Assem.), 27
92612	Shim, 4	92951	Bracket, 4	93747	Name Plate (26-A Typing Unit), 4, 30
92613	Oil Cup, 4	92954	Cam Sleeve, 8	93748	Name Plate (26-B Typing Unit), 4, 30
92614	Clutch (Driving), 4	92998	Bracket, 26	93749	Name Plate (26-C Typing Unit), 4, 30
92615	Gear - 47T, 4	93004	Armature (with Bearings), 23	93750	Name Plate (26-D Typing Unit), 4, 30
92616	Bushing, 4	93005	Rotor (Assem.) (with Bearings and Switch), 22	93751	Name Plate (26-A Teletypewriter Base), 4
92617	Cam Sleeve, 4	93006	Spring Post, 2	93752	Name Plate (26-B Teletypewriter Base), 4
92618	Shift Cam, 4	93029	Base Plate, 14	93753	Name Plate (26-C Teletypewriter Base), 4
92619	Spacer, 4	93030	Lord Mounting, 14, 16	93759	Power Cable (W.D. 1734), 13
92621	Spacer, 4	93031	Screw (10-32 Shoulder), 14, 16	93760	Line Cable (W.D. 1734), 13
92622	Trip Cam, 4	93046	Slip Connection, 13, 16	93764	Copy Retainer (drilled), 27
92623	Spacer, 4	93049	Clutch (Driven), 4	93765	Paper Clip, 27
92624	Bracket, 4	93076	Guard, Bakelite, 1	93766	Terminal Block (Assem.), 20, 30
92625	Trip Lever, 4	93077	Strip Punching, 14, 16	93772	Base Plate, 16
92626	Stud, 2, 4	93078	Plate, 13	93794	Line Cable (W.D. 1727), 18
92627	Screw, (6-40 Special), 4	93079	Cable Retainer, 16	93795	Power Cable (W.D. 1727), 18
92628	Stud, 4	93080	Governor Complete for 3/8 Motor Shaft, 25, 29	93796	Bracket, 26
92629	Bracket, 2	93081	Bakelite Disc, 25	93797	Bracket, 26
92630	Clutch Trip Lever, 2	93082	Fan Blade, 25	93850	Set Screw (6-40 x 1/4), 10
92631	Bushing, 2	93086	Cable (W.D. 1725), 2	93855	Rubber Tube, 14, 16
92632	Hub, 8	93087	Line Cable (W.D. 1725) (Bell System), 13	93876	Guard, 27
92633	Gear, 8	93088	Line Cable (W.D. 1752) (Bell System), 16	93879	Felt Washer, 4
92634	Washer, 8	93089	Bracket, 18	93899	Spring, 3
92635	Overriding Clutch, 8	93090	Motor Unit (Assem.), 24, 29	93901	Guide Disc - Upper, 3
92636	Roller, 8	93092	Cable (W.D. 1735), 25, 30	94008	Name Plate, 19
92641	Transfer Bail, 2	93153	Resistor - 150 Ohms, 17, 18	94044	Synchronous Motor Unit (Assem.) (Bell System), 22
92642	Transfer Arm, 2	93161	Wick, 4	94045	Motor Unit (Assem.) (Bell System), 24
92643	Shaft, 2	93188	Washer, 4	94047	Control Relay (Assem.), 19
92645	Guide Disc - Middle, 3	93197	Set of Power Switch Parts for Send-receive Base, 13	94048	Box, 19
92646	Ribbon Unit Bracket, 3	93198	Set of Power Switch Parts for Receiving only Base, 16	94050	Synchronous Motor 1/40 H.P. 110 V., 60 Cycle, A.C. (Bell System), 22
92647	Plate, 7	93199	Sub Base Plate (Assem.), 17	94051	Motor (1/40 H.P., 110 V., 60 Cycles, A.C. Series) Bell System, 24
92648	Print Hammer Guide, 7	93670	Gothic Type Wheel Pallets (A), 28	94065	Cable, 19
92650	Shaft, 3	93671	(B), 28	94066	Bracket, 19
92653	Retaining Plate, 7	93672	(C), 28	94067	Cords, 19
92654	Type Wheel Hub, 7	93673	(D), 28	94068	Cord (Assem.), 19
92656	Stud (Lower), 7	93674	(E), 28	94077	Wire Lead, 30
92657	Stud (Upper), 7	93675	(F), 28	94338	Resistor (5000 Ohm), 13, 16
92658	Bushing, 7	93676	(G), 28	94326	Plate, 16
92659	Print Follow Arm, 7	93677	(H), 28	94550	Crank, 10
92660	Bushing, 7	93678	(I), 28	94552	Washer (.008), 22, 23, 24
92661	Printing Bail, 7	93679	(J), 28	94553	Washer (.0079), 22, 23, 24
92662	Printing Hammer, 7	93680	(K), 28	94554	Washer (.0112), 22, 23, 24
92663	Ribbon Shield, 3	93681	(L), 28	94555	Washer (.0159), 22, 23, 24
92664	Guide Plate, 2	93682	(M), 28	94556	Washer (.032), 22, 23, 24
92665	Spring, 8	93683	(N), 28	94557	Washer (.0641), 22, 23, 24
92666	Print Link, 2	93684	(O), 28	94602	Wound Stator, 24
92668	Post, 4	93685	(P), 28	94603	Armature (with Bearings), 24
92670	Space Cut-out Lever, 9	93686	(Q), 28	94604	Armature, 24
92671	Stud, 3	93687	(R), 28	94605	End Shield (Assem.), 24
92672	Bushing, 3	93688	(S), 28	94606	End Shield, 24
92673	Shift Lever, 3	93689	(T), 28	94607	Screw (10-32 x 3-1/4), 24
92675	Bushing, 3	93690	(U), 28		
92676	Shift Plate, 3	93691	(V), 28		
92677	Detent, 3	93692	(W), 28		
92678	Blocking Arm, 3	93693	(X), 28		
92679	Bushing, 3	93694	(Y), 28		
92681	Unshift Lever, 3	93694	(Z), 28		
92682	Stud, 3	93695	(1), 28		
92683	Shift Bail, 3	93696	(2), 28		
92684	Stud, 3	93697	(3), 28		
92685	Sleeve, 3	93698	(4), 28		
92686	Shift Stop, 3	93699	(5), 28		
92687	Washer, 2	93700	(6), 28		
92689	Cam Sleeve (Assem.), 4	93701	(7), 28		
92690	Main Frame, 2	93702	(8), 28		
92691	Sleeve, 3	93703	(9), 28		
92695	Bushing, 7	93704	(#), 28		
92697	Ribbon Feed Mechanism (Assem.), 7				
92698	Function Plate (Assem.), 9				
92699	Roller Arm, 4				
92724	Shield, 26				
92730	Cam Sleeve (Assem.), 8				
92733	Eccentric, 4				
92734	Type Wheel (Assem.), 7				

NUMERICAL INDEX

94608	Brush Holder, 24	96831	Set of Paper Bracket Parts (8-1/2), 12	101589	Clamping Washer, 22, 23, 24
94609	Brush (with Spring), 24	96832	Set of Paper Bracket Parts (8), 12	102843	Paper Chute, 12
94662	Spacer, 27	96874	Shim, 4	102844	Paper Chute (Assem.) (8-1/2), 12, 31
94669	Screw (4-40 Shoulder), 1	96878	Guide Disc - Lower (2-15/16" Diam.), 3	104120	Type Wheel Arm, 3
94688	Platen Shaft (Assem.), 10	96879	Spacer (2-1/2" Diam.), 3	104668	Pulsing Contact (Assem) (with Cable), 21
95175	Pawl, 1	96880	Stop Pin (Swaged Lower End), 3	104687	Contact Spring, 21
95177	Bell Hammer, 1	93895	Spring, 9	104688	Guard (Metal), 21
95316	Detent Lever, 30	97317	Clamp Plate, 8	104696	Cable, 21
95317	Set of Parts to apply Signal Distortion Prevention Detent to Keyboards above 240 OPM, 30	97462	Resistor, 21, 300 Ohm, 30	105025	Set of Parts to Provide Lubrication of 26 Printer Type Friction Clutch, 31
95328	Name Plate, 13	97464	Set of Parts for .000-.020 Amp. Operation, 30	105436	Bracket (with Rod), 27
95348	Break Key (with Name Plate), 13	98070	Set of Parts (Upper Case "H" Motor Control Parts for 26 Type Printers for .060 Amp. Line Current), 30	107008	Target (6 and 35 Spots), 23, 24, 25
95378	Spring, 4	98071	Motor Control Bracket, 31	107015	Clamp, 13
95582	Paper Chute, 12	98072	Screw (10-32 x 1), 31	107313	Wire Guard (10" Long), 14
95583	Guide, 12	98073	Cable, 31	107314	Bracket, 13
95935	Bushing, 26	98349	Mounting Post (12-24), 13, 16	107485	Screw (Special), 15
95936	Coil (W.E. Co. 225-A), 26	98350	Mounting Post (12-24), 13	110728	Spring, 31
95937	Condenser .01 M.F. (W.E. Co. D-157918), 26	98351	Nut (12-24 Thumb), 13, 16	110770	Wire Guard (13" Long), 14
95938	Condenser - 1 M.F. (W.E. Co. D-157919), 26	98364	Guard, 25, 29	110853	Carriage Extension (Left), 31
95947	Paper Chute (Assem.) (8), 12	98454	Set of Parts to Equip a Typing Unit with Upper Case "H" Motor Control, 30	110854	Carriage Extension (Right), 31
95964	Button - Blank, 13	98455	Set of Parts to Equip a Keyboard Base with "Upper Case H Motor Control", 31	110855	Paper Chute Extension (Left), 31
96272-R	Wire Lead, 30	99196	Transfer Cam, 4	110856	Paper Chute Extension (Right), 31
96575	Resistor Lead, 26	99245	Container, 26	110888	Set of Parts (Leaf Spring), 31
96763	Shim (.012), 8	99246	Strap, 26	110907	Screw (4-40 Shoulder), 31
96764	Shim (.016), 8	99247	Clamp, 26 - 99251 Filter-26	110933	Washer - .016, 22, 23, 24
96765	Shim (.020), 8	99374	Function Arm, 6	110934	Washer - .032, 22, 23, 24
96776	Friction Disc, 3, 5, 31	99375	Function Arm, 6	110947	Screw (6-32 x 13/16), 23, 24
96806	Function Arm, 6	99376	Function Arm, 6	110988	Set of Parts (Leaf Spring and Paper Chute), 31
96813	Resistance Unit (Assem.) 75-150-300 Ohms, 17, 25, 29	99438	Collar, 2		
96814	Resistance Unit (Assem.) 150-300-600 Ohms, 17, 25, 29	99711	Pin, 22, 23, 24		
96820	Name Plate (26-E Typing Unit), 4				
96821	Name Plate (26-F Typing Unit), 4				

9854 plack bar set of pks. - 1/23/47 ASB
119540 Keyed nut } TC-1013 (WYL)
119541 Capstan nut }