

ADJUSTMENT OF THE RADIO DISTRIBUTOR
(Model 17)

The following adjustments are arranged in a sequence that would be followed if a complete readjustment of the distributor were undertaken. This fact should be kept in mind when a single adjustment is to be made.

The spring tension values given in this specification were derived from measurements made with Teletype spring scales. These scales are calibrated for use in a vertical "pull" position. When used in any other position, the reading is an indicated value. Therefore, in order to obtain the proper spring value readings, the spring scales which are included in the Teletype printer catalog tool list should be used.

NOTE: In all the figures of this specification, fixed pivot points are designated by solid black circles.

Drum Shaft Adjustment

The distributor discs should line up with their respective brushes.

To adjust, loosen the drum shaft bearings mounting screws and position the drum shaft by means of the elongated holes in the bearing brackets. Tighten the mounting screws.

Motor Position Adjustment

The lateral alignment of the motor pinion and the drum shaft gear should be such that the center line of the gear coincides with a vertical line through the center of the hole in the motor pinion, also the lateral alignment of the drum shaft gear and the motor pinion should be such that the center line of the pinion coincides with a vertical line through the center of the hole in the gear.

To adjust, loosen the motor mounting screws and position the motor. Tighten the mounting screws.

Motor Plate Adjustment

There should be a barely perceptible amount of backlash between the motor pinion and the highest point on the drum shaft gear.

To adjust, loosen the motor plate adjusting screws lock nuts and position the motor plate by means of the motor plate adjusting screws. Tighten the lock nut.

Selector Lever Reset Bail Cam Follower Roller Adjustment (Figure 1-A)

With the selector lever reset bail cam follower rollers on the high part of their cams, there should be approximately equal clearance between the selector levers and the code bars at both ends of the code bars; and there should be .010" to .015" clearance between the code bars and the selector lever having the least clearance.

NOTE: After making a single adjustment, check related adjustments.
(See paragraph 1, page 1.)

To adjust, loosen the eccentric mounting screws and position the eccentrics. Tighten the mounting screws.

Selector Magnets Adjustment

Each selector magnet armature screw should line up with its respective backstop screw and code bar latch.

To adjust, loosen the selector magnet mounting screws and position the selector magnets by means of their enlarged mounting holes. Tighten the mounting screws. (See Figure 2 for location of parts.)

Selector Magnet Armature Screws Adjustment (Figure 2)

NOTE: While checking this adjustment, hold the selector magnet armatures operated so that the code bars are unlatched, or in their marking position.

Rotate the drum shaft until the code bar reset bail has left the code bars and the selector lever reset bail cam rollers are on the low part of their cams. There should be some clearance, not more than .008" between the code bar latches and the projection on the code bars when the armatures are attracted.

To adjust, loosen the armature screw lock nut and position the screw. Tighten the lock nut.

Selector Magnet Armature Backstop Screws Adjustment

There should be .020" to .025" clearance between the backstop screws and the armature screws when the armatures are attracted.

To adjust, loosen the backstop screws lock nuts and position the backstop screws. Tighten the lock nuts. (See Figure 2 for location of parts.)

Code Bar Reset Bail Cam Follower Arm Link Adjustment (Figure 3)

Rotate the drum shaft until the code bar reset bail cam follower roller is on the high part of its cam. There should be .020" to .030" clearance between the code bar latch and the code bar projection having the least clearance.

To adjust, loosen the cam follower arm link mounting screws and position the link. Tighten the mounting screws.

Upper Brush Arm Rail Adjustment (Figure 1-A)

Rotate the drum shaft until the selector lever reset bail cam rollers are on the low part of their cams. There should be some clearance, not more than .008" between the brush arm and the selector lever having the least clearance. This clearance should be approximately equal at each end of the machine.

NOTE: After making a single adjustment, check related adjustments. (See paragraph 1, page 1.)

To adjust, loosen the upper brush arm rail mounting screws and position the upper brush arm rail. Tighten the mounting screws.

Transmitting Brush Adjustment (Figure 1-A)

With the brush arms resting against the upper brush arm rail there should be .015" to .025" clearance between the ends of each brush and the high copper segments of their respective discs. The ends of the brushes should also be in line with their respective discs.

To adjust, loosen the transmitting brush mounting screws and position the brush by means of their elongated mounting holes. Tighten the mounting screws.

Collector Ring Brush Tension Adjustment (Figure 2)

Hook an 8 oz. scale under a collector ring brush, near the end, and pull at right angles to the brush. It should require 3 to 4 ozs. to pull each collector ring brush away from its collector ring.

To adjust, loosen the collector ring brush mounting screws and position the collector ring brushes by means of their elongated mounting holes. Tighten the mounting screws.

Lower Brush Arm Rail Adjustment

Rotate the drum shaft to a point where there are no high copper segments opposite the brushes. There should be .030" to .040" clearance between a brush arm and the lower rail when the brush is just touching the drum. Check several brush arms at each end of the drum shaft.

To adjust, loosen the lower brush arm rail mounting screws and position the lower brush arm rail. Tighten the mounting screws. (See Figure 1-A for location of parts.)

Brush Arm Locking Bail End Play Adjustment

The brush arm locking bail should have some end play, not more than .004".

To adjust, loosen the lock nuts for the brush arm locking bail pivot screws and position the pivot screws. Tighten the lock nuts. (See Figure 1-A for location of parts.)

Brush Arm Locking Bail Cam Follower Arm Adjustment (Figure 1-A)

There should be .020" to .030" clearance between the locking bail cam follower arm roller and the low part of its cam.

To adjust, loosen the locking bail cam follower arm mounting screw and position the arm. Tighten the mounting screw.

NOTE: After making a single adjustment, check related adjustments.
(See paragraph 1, page 1.)

Transmitter Pulsing Contact Springs Adjustment (Figure 4-A)

Rotate the drum shaft until the fibre on the long contact spring is on the low part of its cam and proceed as follows:

- (a) Hook an 8 oz. scale over the fibre end of the long contact spring. It should require 1 to 2 ozs. to pull the fibre away from the cam.

To adjust, bend the long contact spring.

- (b) There should be .015" to .020" clearance between the contact points, and the contact points should meet flat across their entire surface.

To adjust, bend the short contact spring stiffener.

- (c) Hook an 8 oz. scale to the short contact spring, at the contact point. It should require 2-1/2 to 3-1/2 ozs. to pull the short contact spring away from its stiffener.

To adjust, bend the short contact spring and recheck (b).

Start Contact Springs Adjustment (Figure 4-B)

With the brush arms resting against the upper rail, proceed as follows:

- (a) There should be .008" to .015" clearance between the fibre end of the long contact spring and the extension on the start brush.

To adjust, loosen the extension mounting screws and position the extension (recheck the Transmitting Brush Adjustment). Tighten the mounting screws.

- (b) There should be .010" to .015" clearance between the contact points.

To adjust, bend the short contact spring stiffener.

- (c) Hook an 8 oz. scale to the short contact spring, at the contact point and pull at right angles to the contact spring. It should require 2 to 3 ozs. to pull the short contact spring away from its stiffener.

To adjust, bend the short contact spring and recheck (b).

Shift and Unshift Contact Springs Adjustment (Figure 4-C)

Depress the contact operating lever detent manually and proceed as follows:

- (a) There should be .015" to .020" clearance between the center contact points and each of the other contact points.

To adjust, bend the stiffeners for the outer contact springs.

- (b) Hook an 8 oz. scale to each of the outer contact springs at the contact point. It should require 2-1/2 to 3-1/2 ozs. to pull each contact spring away from its stiffener.

NOTE: After making a single adjustment, check related adjustments.
(See paragraph 1, page 1.)

To adjust, bend the short contact springs and recheck (a)

Shift and Unshift Contact Bracket Position Adjustment

Depress the detent manually. There should be equal clearance between the shift and unshift selector levers and their respective bell cranks when the center contact spring is in its center position; and the peak of the detent should line up with the peak of the contact operating lever.

To adjust, loosen the contact bracket mounting screws and position the bracket by means of its elongated mounting holes. Tighten the mounting screws. (See Figures 2 and 4 for location of parts.)

Auto Control Relays Adjustments

Adjust the auto control relays in accordance with Bulletin 191.

Start Signal Relay Adjustments (Figure 5)

- (a) When the armature is manually operated, there should be some clearance, not more than .004" between the armature and the magnet core. (See Figure 5-A.)

To adjust, loosen the residual screw lock nut and position the screw. Tighten the lock nut.

- (b) When the armature is manually operated there should be .020" to .025" clearance between the "break" contact points. When the armature is released, there should be approximately .010" "follow" as the "break" contacts close. (See Figure 5-A.)

To adjust, bend the stationary contact spring.

- (c) With the armature arm resting against the armature arm backstop, there should be some clearance, not more than .008" between the insulating button on the armature arm and the contact spring which it engages. (See Figure 5-B.)

To adjust, bend the armature arm backstop.

- (d) There should be .015" to .020" clearance between the "make" contact points when the armature is released. (See Figure 5-B.)

To adjust, bend the stationary contact springs of the two "make" pairs of contact springs.

Cam Settings

Mount a disc, graduated in degrees, on the drum shaft, and arrange a pointer for it (a piece of wire). Select the "start" brush manually and rotate the drum shaft until the "start" brush just touches the high copper segment on the "start" disc. Set the pointer to 0° for this position. Rotate the drum shaft and check the cam settings as follows:

NOTE: After making a single adjustment, check related adjustments.
(See paragraph 1, page 1.)

- (a) The transmitter pulsing contact points close at 265° plus or minus 5° .
- (b) The selector levers touch the code bars at 275° plus or minus 5° .

NOTE: There are two cams controlling the operation of the selector lever bail. These cams should be set so that the selector levers touch the code bars at both ends of the code bars at the same time.

- (c) Peak of brush unlock at 320° plus or minus 5° .
- (d) With the code bars in the marking position (unlatched), the reset bail should just touch the code bars at 48° plus or minus 5° .

To adjust, loosen the cam set screws, position the cams and then lock the cams by means of their set screws.

Code Bar Spring Tension

Rotate the drum shaft until the code bar reset bail cam follower roller is on the low part of its cam, then attract an armature manually, thus releasing a code bar. Apply the push end of an 8 oz. scale to the code bar. It should require 2-1/4 to 3-1/4 ozs. to start each code bar moving.

Code Bar Latch Spring Tension

Rotate the drum shaft until the code bar reset bail cam follower roller is on the high part of its cam. Hook an 8 oz. scale under the end of the horizontal arm of a code bar latch and pull vertically upward. It should require 3/4 to 1-1/2 ozs. to start each code bar latch moving. (See Figure 2 for location of parts.)

Selector Lever Reset Bail Spring Tension

With the selector lever reset bail cam follower rollers on the low part of their cams, unhook a selector lever reset bail spring from the spring plate and hook a 32 oz. scale in the spring eye. It should require 26 to 32 ozs. to pull each spring to its position length. (See Figure 1-A for location of parts.)

Shift and Unshift Contact Operating Lever Detent Spring Tension

Hold the shift and unshift contact operating lever in its right position (nearest the motor). Apply the push end of an 8 oz. scale just to the left of the peak on the detent and push downward. It should require 3-1/2 to 5-1/2 ozs. to start the detent moving. (See Figure 2 for location of parts.)

Code Bar Reset Bail Spring Tension

Rotate the drum shaft until the code bar reset bail cam follower roller is on the low part of its cam. Hook a 32 oz. scale under the front end of the cam follower arm link and pull upward. It should require 9 to 13 ozs. to start the link moving. (See Figure 3 for location of parts.)

NOTE: After making a single adjustment, check related adjustments.
(See paragraph 1, page 1.)

Transmitting Brush Spring Tension (Figure 1-B)

Rotate the drum shaft until the brush arm locking cam follower roller is on the high part of its cam. Hook an 8 oz. scale over the head of a brush mounting screw and pull toward the drum. It should require 1-1/2 to 3 ozs. to start each brush moving.

Selector Lever Spring Tension

Rotate the drum shaft until the selector levers rest against the code bars. Turn the unit upside down. Unhook a selector lever spring from the spring plate and hook a 12 lb. scale in the spring eye. It should require 4-1/4 to 5-3/4 lbs. to stretch the "start," "shift" and the "unshift" selector lever springs to their position lengths. All other selector lever springs should require 1-3/4 to 2-3/4 lbs. to stretch to their position lengths. (See Figure 1-A for location of parts.)

Return the unit to its normal upright position.

Brush Arm Locking Bail Spring Tension (Figure 1)

With the brush arm locking bail cam follower roller on the low part of its cam, hook a 12 lb. scale under the spring post on the brush arm locking bail and pull in line with the spring. It should require 5-1/2 to 7 lbs. to start the locking bail moving.

NOTE: After making a single adjustment, check related adjustments.
(See paragraph 1, page 1.)

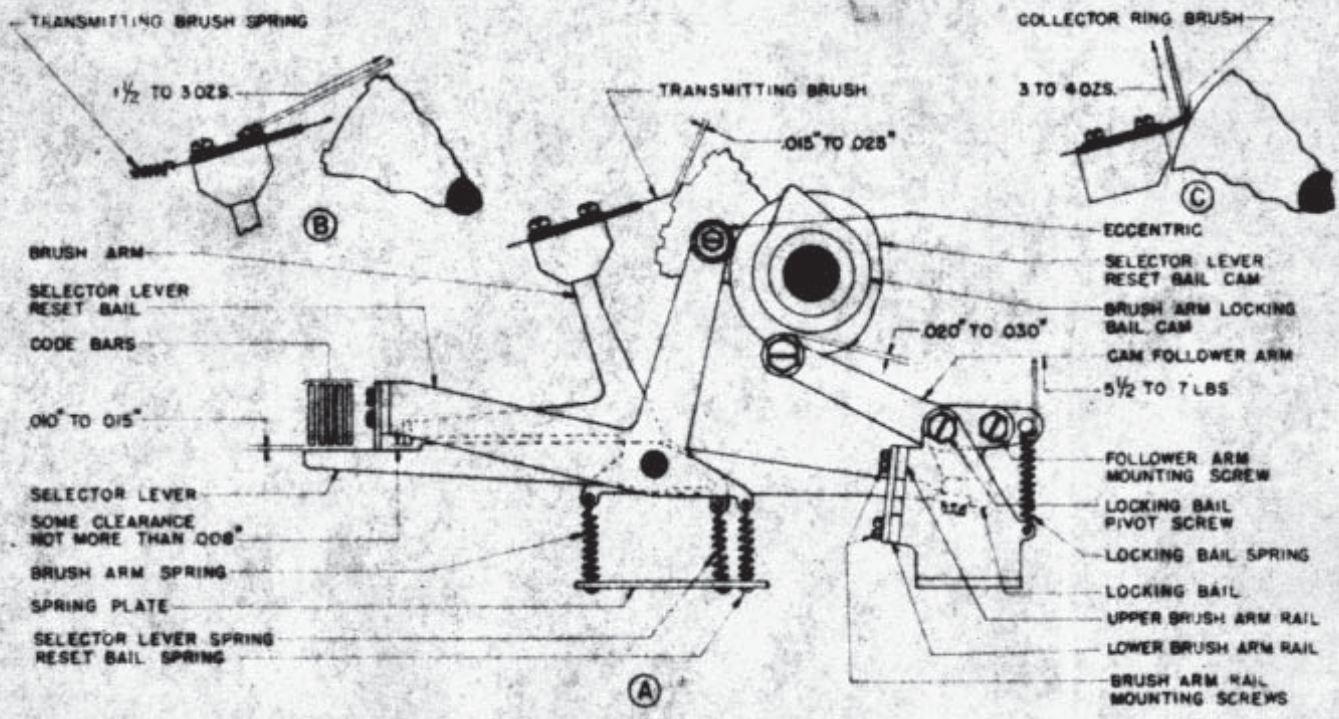

FIGURE 1

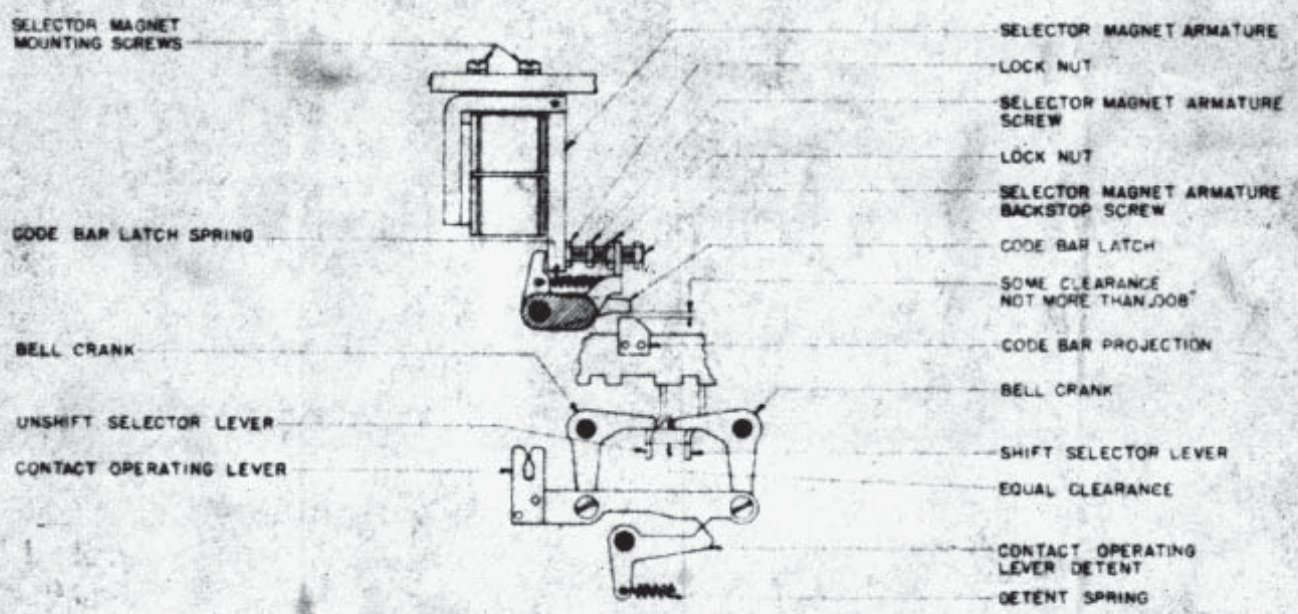

FIGURE 2

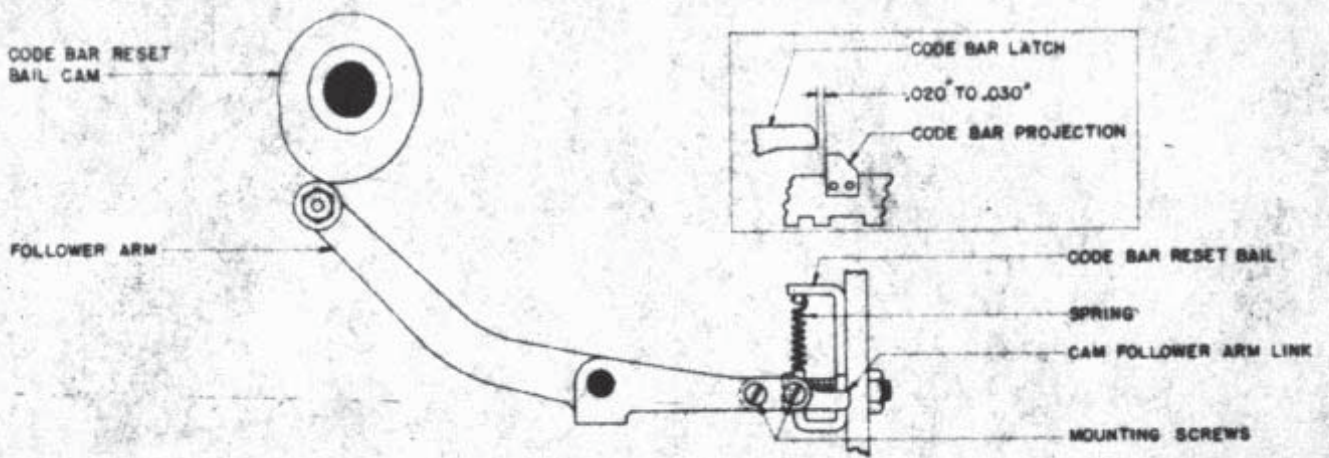

FIGURE 3

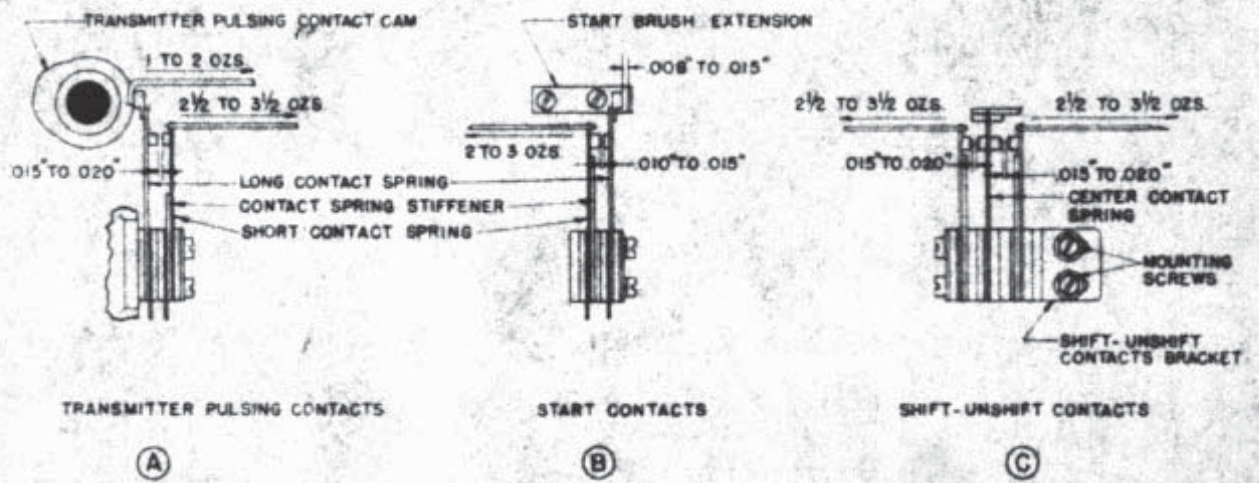

FIGURE 4

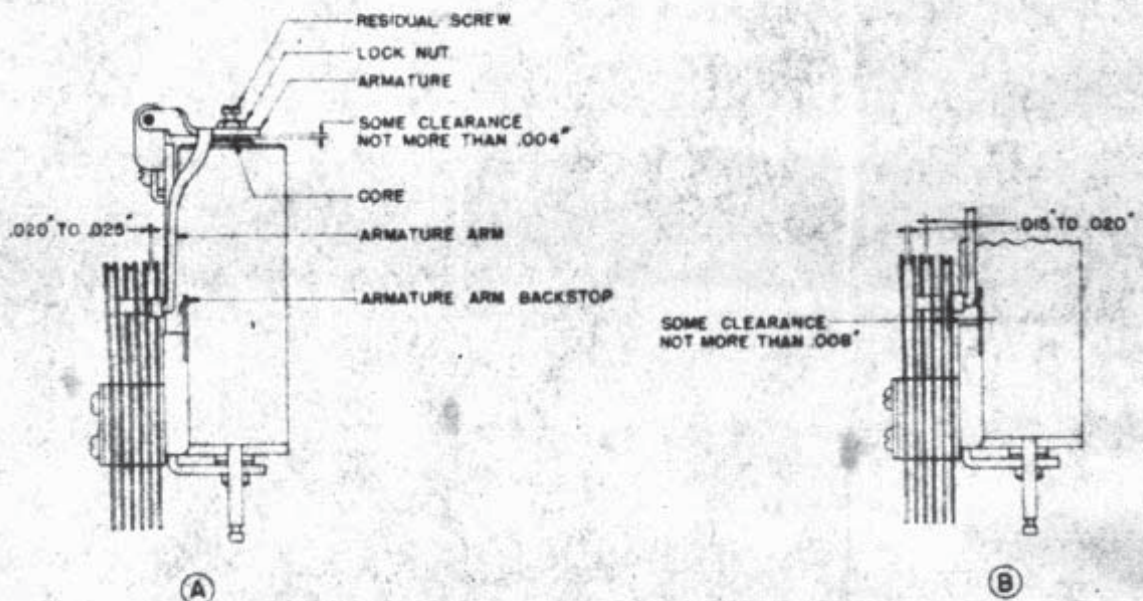

FIGURE 5