

U. S. ARMY SIGNAL CORPS  
PRINTERS TG-7-A, TG-7-B AND TG-37-B  
WITH CHESTS CH-50-A AND CH-50-B  
AND CHESTS CH-62-A AND CH-62-B

General Description

The U. S. Army Signal Corps, portable sending-receiving printing telegraph sets, TG-7-A, TG-7-B, and TG-37-B, herein described each include a printer and two carrying cases. The printer consists of a Teletype Model 15 printer base, keyboard, with radio filter, typing unit, motor unit with radio filter, and cover. A radio filter connected in the power leads of all TG-37-B printers, and TG-7-B printers of later manufacture, provides additional radio interference suppression. The base, keyboard, motor unit and cover, are carried in chest CH-50. The typing unit, is carried in chest CH-62.

The TG-7-A and TG-7-B printers are arranged for ordinary message communication service and the TG-37-B printers are arranged for weather report service.

For ordinary message communication service, (TG-7-A and TG-7-B), the "upper case" (or "figures") positions of the printer type and keyboard keys carry the ten digits and customary abbreviation and punctuation marks. The printer is adjusted to print 72 characters per line. An automatic remote motor control feature is provided whereby the motors of all printers on the circuit may be started by momentarily opening the signal line and stopped by transmitting the "upper case H" signal combination from the keyboard at any station. Printing on "upper case H" is suppressed.

For weather report service, (TG-37-B), the "upper case" (or "figures") positions of the printer type and keyboard keys carry the ten digits and necessary weather symbols. The printer is arranged to print and space on the "upper case blank" combination, and suppresses printing and spacing on "lower case blank." The "carriage return" and "line feed" functions are effective in the "lower case" (or "letters") positions only. The printer is adjusted to print 76 characters per line. The automatic remote motor control feature on this printer is arranged so that all motors on the circuit may be started by momentarily opening the signal line as in the TG-7 printers. However, to stop the motors it is necessary to transmit "upper case BLANK and H" combinations from the keyboard at any station. The "minus or hyphen" on "upper case BLANK" and the north wind symbol on "upper case H" will be printed.

Note: The manual includes two issues of Specification S-5408. Issue 1 covers the instructions for use of printers TG-7-A and TG-7-B of earlier manufacture in which the typing unit is attached to chest CH-62-B base by means of 4 mounting screws. Issue 2 covers the TG-37-B and those TG-7-B printers having three clamps and locating blocks on the mounting frame substituted for the 4 screws.

2.

Two line cords attached to the printer base are provided for connection to a line box (Signal Corps BE-77 or equivalent, not furnished by Teletype Corporation) and a third cord is for connection to the power outlet. A switch, accessible through a hole in the front of the printer cover, is provided for controlling the power to the printer motor.

A resistor assembly with switch is located on the right side of the printer base. These resistors may be switched in series with the motor power to permit operation on various power supplies, as follows:

<u>TG-7-A</u>	<u>Position of Switch</u>
115 volts DC or AC 25 cycles, or 115 volts AC 50-60 cycles	up down
<u>TG-7-B and TG-37-B</u>	
115 volts AC 40 cycles, or 115 volts DC or AC 25 cycles, or 115 volts AC 50-60 cycles	up center down

The following features, present on printers TG-7-A have been omitted from printers TG-7-B and TG-37-B:

1. Motor control relay for separate line motor control.
2. Polar neutral switching key.
3. Line relay mounting with associated resistors, spark suppression condenser and radio filter.
4. Tuning fork (for setting motor speed) with holder.

These features are not normally required in the service for which printers TG-7 and TG-37, with chests, are intended. However, in case need should arise, the procedure for operation of printer TG-7-A (with features Nos. 2 and 3 restored) with Teletype RY-30 (W.E. Co. 255-A) or RY28 (W.E. Co. 215-H) relays and other fixed station equipment (metal tables and dry disc rectifiers) is covered in Specification S-5346.

The procedure for operation of printers TG-7-B or TG-37-B in a like manner, requires the installation of a set of parts and is covered by Specification S-5404.

CUT ALONG THIS LINE BEFORE CEMENTING TO CHEST COVER

TELETYPE CORPORATION  
CHICAGO, ILLINOIS, U.S.A.

**INSTRUCTIONS FOR USE OF SIGNAL CORPS PRINTER TG-7-A**

**CHEST CH-50-A (TELETYPE IO3370)**

**CHEST CH-62-A (TELETYPE IO3368)**

SPECIFICATION S-5341  
ISSUE 2  
JANUARY, 1942

**TO PREPARE PRINTER SET FOR OPERATION**

1. SET CHEST CH-50-A BASE ON CHEST CH-50-A COVER AS SHOWN IN FIGURE 2.
2. REMOVE PRINTER COVER AND REMOVE THE THREE KNURLED THUMB SCREWS FROM PRINTER BASE.
3. REMOVE TYPING UNIT FROM CHEST CH-62-A BASE BY REMOVING THE FOUR MOUNTING SCREWS USING WRENCH SHOWN IN FIGURE 4.
4. PLACE TYPING UNIT ON PRINTER BASE AND SECURE WITH THE THREE KNURLED THUMB SCREWS.
5. REPLACE THE FOUR MOUNTING SCREWS AND WRENCH IN CHEST CH-62-A BASE.
6. REPLACE PRINTER COVER AND INSTALL PLATEN CRANK ON PLATEN SHAFT.
7. PLACE CHEST CH-62-A COVER ON CHEST CH-62-A BASE. POSITION CHEST AS SHOWN IN FIGURE 1.
8. POSITION THE AC-DC SWITCH FOR AVAILABLE POWER SUPPLY.

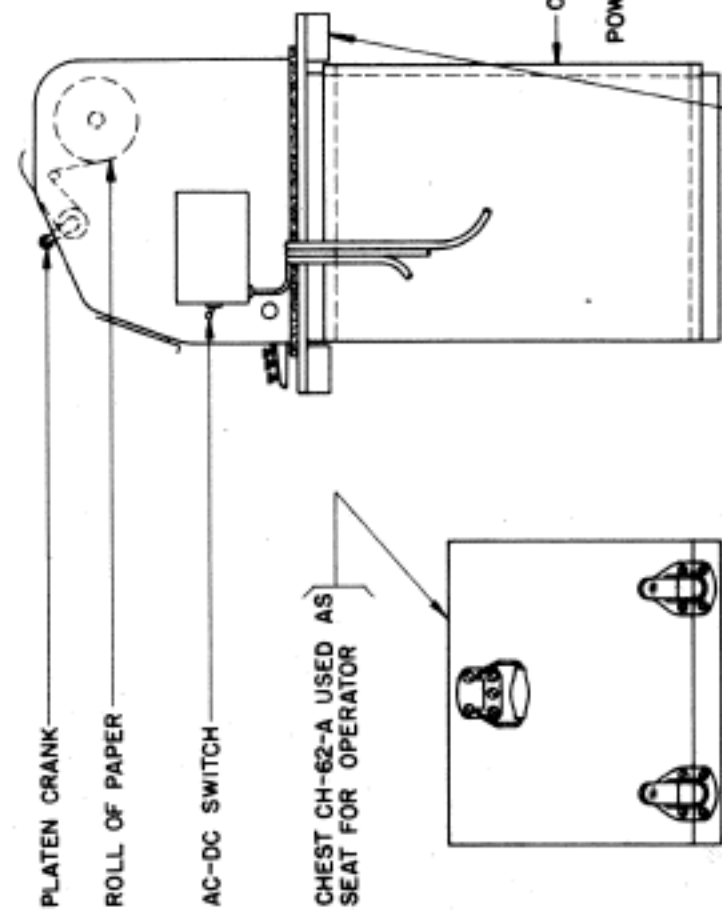

FIGURE 1.

**TO PREPARE PRINTER SET FOR TRANSPORTATION**

1. REMOVE COVER OF CHEST CH-62-A.
2. REMOVE PLATEN CRANK FROM PLATEN SHAFT AND PLACE ON CHEST CH-62-A BASE AS SHOWN IN FIGURE 4.
3. REMOVE THE FOUR MOUNTING SCREWS FROM BASE OF CHEST CH-62-A.
4. REMOVE PRINTER COVER AND REMOVE THE THREE KNURLED THUMB SCREWS SECURING TYPING UNIT.
5. PLACE TYPING UNIT ON CHEST CH-62-A BASE AS SHOWN IN FIGURE 4, AND INSTALL THE FOUR MOUNTING SCREWS. TIGHTEN MOUNTING SCREWS WITH WRENCH AND REPLACE WRENCH IN HOLDER ON BASE.
6. PRESS CARRIAGE RETURN LOCK BAR (AT LEFT REAR OF TYPING UNIT) TO RETURN TYPE BASKET TO EXTREME LEFT POSITION. TURN MAIN SHAFT GEAR BY HAND AT LEAST ONE FULL TURN IN COUNTERCLOCKWISE DIRECTION (VIEWED FROM GEAR END), TO ASSURE PROPER POSITIONING OF ALL PARTS WHICH LOCK THE TYPE BASKET SECURELY IN PLACE.
7. REPLACE THE THREE KNURLED THUMB SCREWS IN PRINTER BASE AND REPLACE PRINTER COVER.
8. WRAP POWER AND LINE CORDS AROUND COPYHOLDER AS SHOWN IN FIGURE 3.
9. PLACE EACH CHEST COVER OVER PROPER BASE AND LATCH.

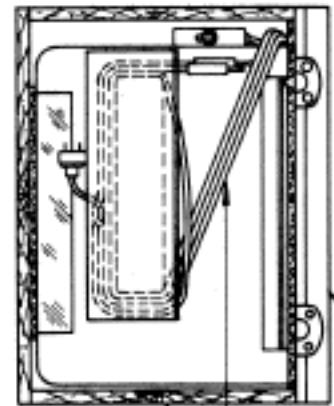

FIGURE 3.

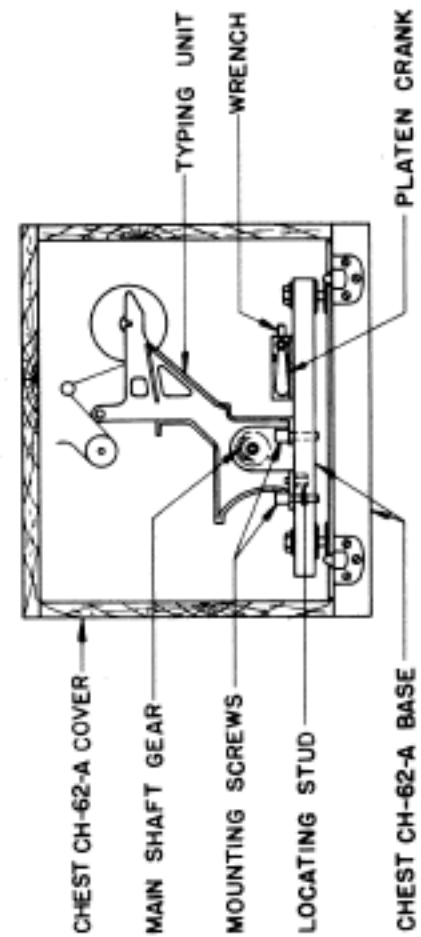

FIGURE 4.

CUT ALONG THIS LINE BEFORE CEMENTING TO CHEST COVER

TELETYPE CORPORATION  
CHICAGO, ILLINOIS, U. S. A.

INSTRUCTIONS FOR USE OF SIGNAL CORPS PRINTER TG-7-B

CHEST CH-50-B (TELETYPE IO5229)

CHEST CH-62-B (TELETYPE IO5367)

TO PREPARE PRINTER SET FOR OPERATION

1. SET CHEST CH-50-B BASE ON CHEST CH-50-B COVER AS SHOWN IN FIGURE 2.
2. REMOVE PRINTER COVER.
3. REMOVE TYPING UNIT FROM CHEST CH-62-B BASE BY REMOVING THE FOUR MOUNTING SCREWS USING WRENCH IN ACCESSORY BOX ON CHEST CH-62-B BASE SHOWN IN FIGURE 4.
4. PLACE TYPING UNIT ON PRINTER BASE AND SECURE WITH THE THREE KNURLED THUMB SCREWS IN ACCESSORY BOX.
5. PLACE THE FOUR MOUNTING SCREWS AND WRENCH IN ACCESSORY BOX ON CHEST CH-62-B BASE AND REMOVE THE PLATEN CRANK FROM THE BOX.
6. REPLACE PRINTER COVER AND INSTALL PLATEN CRANK ON PLATEN SHAFT.
7. LATCH CHEST CH-62-B COVER ON CHEST CH-62-B BASE. POSITION CHEST AS SHOWN IN FIGURE 1.
8. BEFORE STARTING THE PRINTER MOTOR POSITION AND LOCK AC-DC SWITCH TO MATCH THE AVAILABLE POWER SUPPLY.

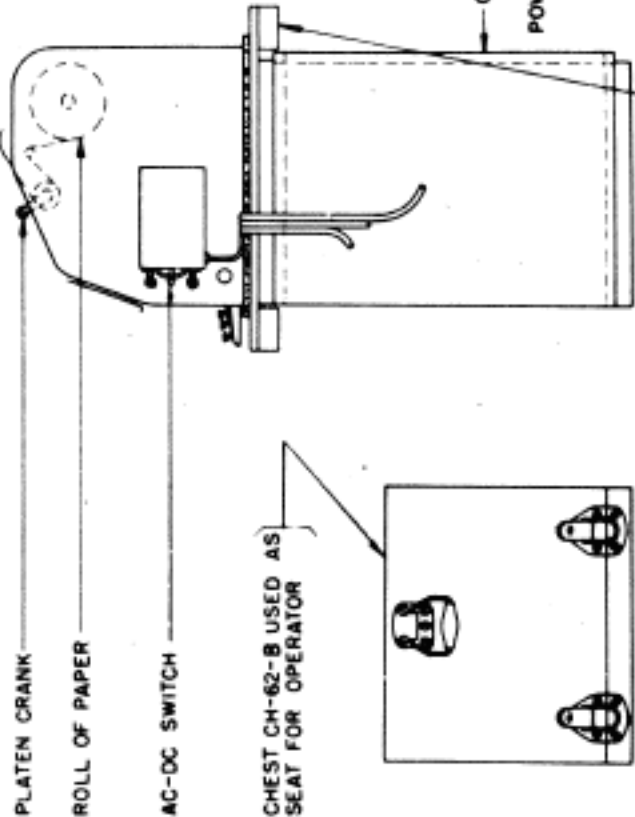

FIGURE 1.

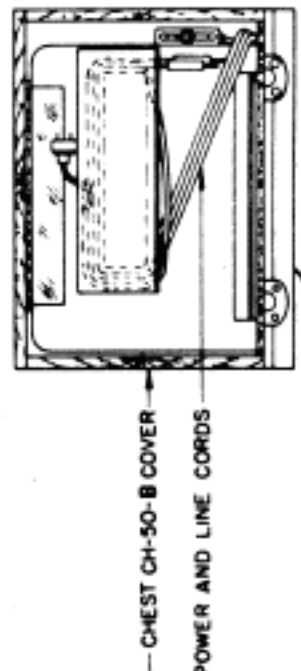

FIGURE 2.

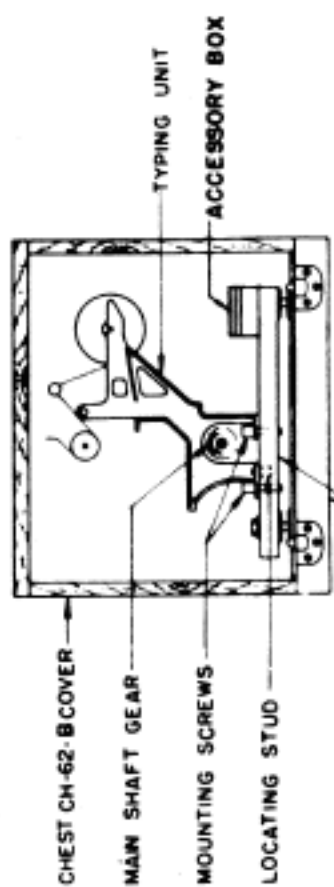

FIGURE 4.

SPECIFICATION S-5408  
ISSUE 1  
JANUARY, 1943

TO PREPARE PRINTER SET FOR TRANSPORTATION

1. REMOVE COVER OF CHEST CH-62-B.
2. REMOVE PLATEN CRANK FROM PLATEN SHAFT AND PLACE IN ACCESSORY BOX ON CHEST CH-62-B BASE SHOWN IN FIGURE 4. ALSO REMOVE THE FOUR MOUNTING SCREWS AND WRENCH FROM THE BOX.
3. REMOVE PRINTER COVER AND REMOVE THE THREE KNURLED THUMB SCREWS SECURING TYPING UNIT AND PLACE THE THUMB SCREWS IN ACCESSORY BOX.
4. PLACE TYPING UNIT ON CHEST CH-62-B BASE AS SHOWN IN FIGURE 4 AND INSTALL THE FOUR MOUNTING SCREWS. TIGHTEN MOUNTING SCREWS WITH WRENCH AND REPLACE WRENCH IN ACCESSORY BOX.
5. PRESS CARRIAGE RETURN LOCK BAR (AT LEFT REAR OF TYPING UNIT) TO RETURN TYPE BASKET TO EXTREME LEFT POSITION. TURN MAIN SHAFT GEAR BY HAND AT LEAST ONE FULL TURN IN COUNTERCLOCKWISE DIRECTION (VIEWED FROM GEAR END), TO ASSURE PROPER POSITIONING OF ALL PARTS WHICH LOCK THE TYPE BASKET SECURELY IN PLACE.
6. REPLACE PRINTER COVER.
7. WRAP POWER AND LINE CORDS AROUND COPYHOLDER AS SHOWN IN FIGURE 3.
8. PLACE EACH CHEST COVER OVER PROPER BASE AND LATCH.



CUT ALONG THIS LINE BEFORE CEMENTING TO CHEST COVER

TELETYPE CORPORATION  
CHICAGO, ILLINOIS, U.S.A.

### INSTRUCTIONS FOR USE OF SIGNAL CORPS PRINTERS TG-7-B AND TG-37-B

SPECIFICATION S-5408  
ISSUE 2  
AUGUST, 1943

CHEST CH-50-B (TELETYPE IO5229)  
CHEST CH-62-B (TELETYPE IO5367)

#### TO PREPARE PRINTER SET FOR OPERATION

1. SET CHEST CH-50-B BASE ON CHEST CH-50-B COVER AS SHOWN IN FIGURE 2.
2. REMOVE PRINTER COVER.
3. REMOVE TYPING UNIT FROM CHEST CH-62-B BASE AFTER LOOSENING THE THREE WING NUTS AND MOVING THE MOUNTING CLAMPS AWAY FROM THE PRINTER FEET.
4. PLACE TYPING UNIT ON PRINTER BASE AND SECURE WITH THE THREE KNURLED THUMB SCREWS IN ACCESSORY BOX ON CHEST CH-62-B BASE SHOWN IN FIGURE 4.
5. REMOVE RIGHT CARRIAGE RETAINING HOOK WHILE HOLDING CARRIAGE WITH LEFT HAND. RELEASE CARRIAGE TO LEFT AND REMOVE LEFT CARRIAGE RETAINING HOOK. PLACE HOOKS IN ACCESSORY BOX ON CH-62-B BASE. REMOVE PLATEN CRANK FROM THE BOX.
6. REPLACE PRINTER COVER AND INSTALL PLATEN CRANK ON PLATEN SHAFT.
7. LATCH CHEST CH-62-B COVER ON CHEST CH-62-B BASE. POSITION CHEST AS SHOWN IN FIGURE 1.
8. BEFORE STARTING THE PRINTER MOTOR, POSITION AND LOCK AC-DC SWITCH TO MATCH THE AVAILABLE POWER SUPPLY.

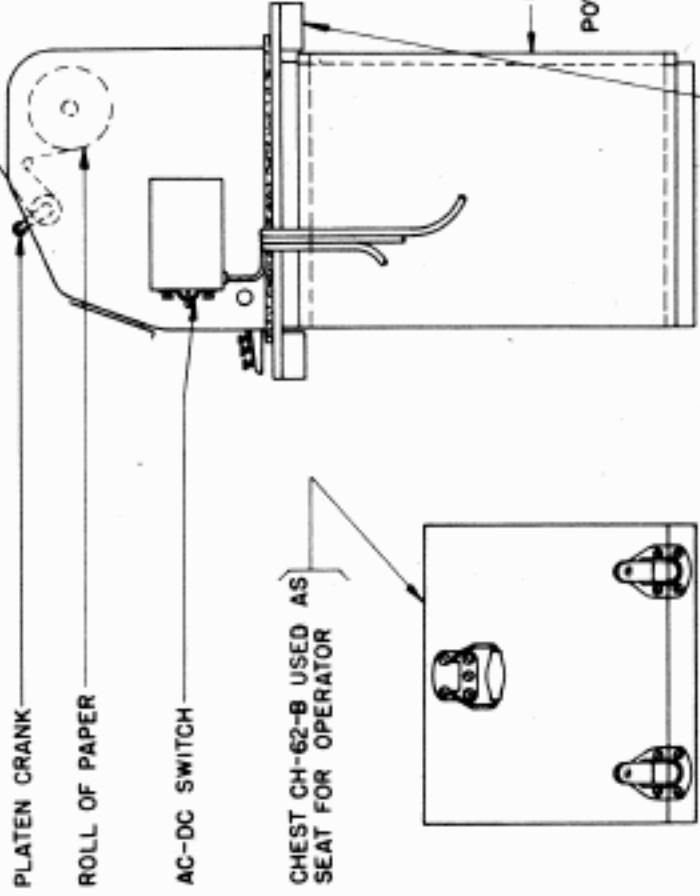

FIGURE 1.

#### TO PREPARE PRINTER SET FOR TRANSPORTATION

1. REMOVE COVER OF CHEST CH-62-B.
2. REMOVE PLATEN CRANK FROM PLATEN SHAFT AND PLACE IN ACCESSORY BOX ON CHEST CH-62-B BASE SHOWN IN FIGURE 4.
3. REMOVE PRINTER COVER AND REMOVE THE THREE KNURLED THUMB SCREWS SECURING TYPING UNIT AND PLACE THUMB SCREWS IN ACCESSORY BOX.
4. PLACE TYPING UNIT ON CHEST CH-62-B BASE AS SHOWN IN FIGURE 4 AFTER MOVING MOUNTING CLAMPS TO ONE SIDE. THEN POSITION CLAMPS ON FEET OF PRINTER AND TIGHTEN WING NUTS. (IMPORTANT: POSITION THE STUDS ON THE TWO SHORT CLAMPS IN PROPER LOCATING HOLES BEFORE TIGHTENING.)
5. PRESS CARRIAGE RETURN LOCK BAR BUTTON (AT LEFT REAR OF TYPING UNIT) TO POSITION CARRIAGE IN ITS LEFT HAND POSITION. HOOK THE LARGE END OF THE "S" SHAPED HOOK ON THE LEFT CARRIAGE ROLLER MOUNTING STUD FROM UNDER SIDE. PRESS THE CARRIAGE RETURN LOCK BAR BUTTON AGAIN AND AT THE SAME TIME MOVE THE CARRIAGE TO THE RIGHT UNTIL THE SMALL END OF HOOK ENGAGES THE LEFT FRONT CARRIAGE TRACK SUPPORT. HOLD CARRIAGE IN THIS POSITION AND HOOK THE LARGE END OF THE OTHER HOOK ON THE RIGHT CARRIAGE ROLLER MOUNTING STUD AND PRESS DOWN ON OTHER END UNTIL HOOK SNAPS INTO PLACE ON THE RIGHT FRONT CARRIAGE TRACK SUPPORT AS SHOWN IN FIGURE 4.
6. REPLACE PRINTER COVER.
7. WRAP POWER AND LINE CORDS AROUND COPYHOLDER AS SHOWN IN FIGURE 3.
8. PLACE EACH CHEST COVER OVER PROPER BASE AND LATCH.

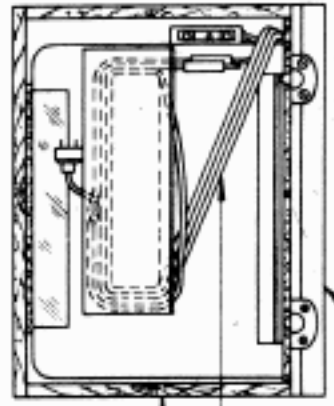

FIGURE 3.

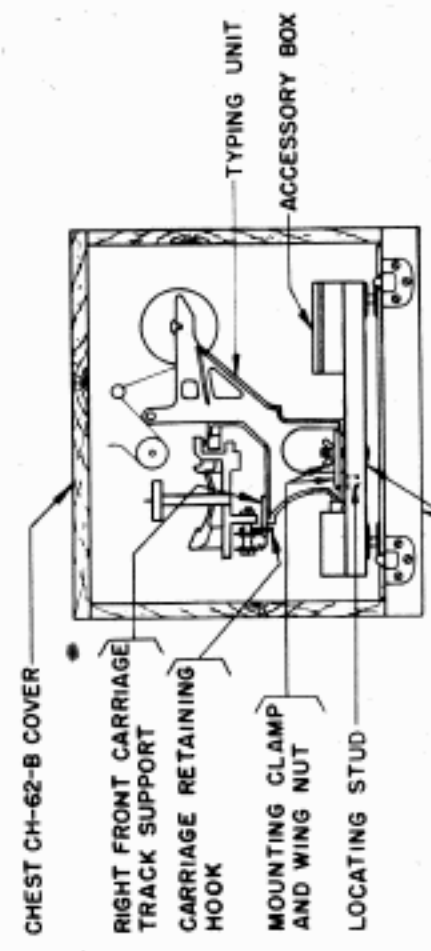

FIGURE 4.