

INSTRUCTIONS FOR INSTALLING, ADJUSTING AND PARTS ORDERING
INFORMATION FOR THE 128700 TORN FEED HOLE TAPE
STOP ASSEMBLY, FOR USE ON A MODEL 14 TRANSMITTER DISTRIBUTOR

1. GENERAL

a. The 128700 torn feed hole tape stop assembly replaces the standard top plate assembly on a transmitter distributor, equipped with sixth pin or end-of-tape stop contacts, to advance the tape and to stop transmission when torn feed holes prevent the tape from being advanced.

b. For part numbers referred to in the following text but not included in the above mechanism refer to Teletype Model 14 Transmitter Distributor Parts Bulletin.

2. THEORY OF OPERATION

*a. The downward motion of the feed pawl rotates half of the contact operating cam (Figure 19.3) through the medium of the feed roll gear and the contact operating cam gear; it also advances the perforated tape (tape feed holes mesh with the feed roll pins). The motion imparted to the tape rotates the feed wheel (feed wheel pins mesh with the feed holes in the tape) which rotates the other half of the contact operating cam (through the medium of the spring clutch). This half of the cam may also be rotated by movement of the reset wheel through its spring clutch.

b. In the reset position the notches in each half of the contact operating cam are out of alignment, the contact operating cam arm (Figure 19.3) is held on the outer periphery of the cams and keeps the tape-out contacts of the transmitter distributor closed.

c. If the feed holes are torn, the tape no longer transmits the motion to the feed wheel. This causes one-half of the cam to rotate and the other half to remain stationary until the notches in the cams are in line, at which time both cams rotate together until the contact operating arm cam follower falls in the aligned notches opening the tape-out contacts to stop transmission. After tape has stopped due to torn feed holes, transmission is stopped after 3 to 15 repeat characters. After transmission has stopped due to torn feed holes or end of tape, mechanism must be manually reset before transmission can be resumed.

NOTE: Adjustments 4a, b, c, d, e, f, g may be made before installation of the 128700 assembly on the transmitter distributor.

3. INSTALLATION

a. Remove the transmitter snap panel, and the transmitter distributor cover.

b. Remove the four top plate assembly mounting screws and remove the top plate assembly and the tape guide wire.

c. Install the 128700 assembly on the transmitter distributor using the four top plate mounting screws; hold the feed pawl up so that it engages the feed wheel ratchet and hold the contact operating arm so when the assembly is installed the arm rests upon the insulator of the upper tape-out contact.

d. Refer to paragraphs 4i and j and check the Detent Bracket and End-of-Tape Stop Contact Spring Adjustments.

e. Replace the snap panel, and the cover.

4. ADJUSTMENTS

a. FEED WHEEL SHAFT BEARINGS

*Apply standardized adjusting procedure.

b. DETENT LEVER SPRING TENSION (Figure 16)

*Apply standardized adjusting procedure.

c. TAPE RETAINING LID LATCH WEARING STRIP SHIMS (Figure 19.1)

*Apply standardized adjusting procedure.

d. TAPE SPACE (Figure 18)

*Apply standardized adjusting procedure.

e. TAPE FINGER (Figure 19.2)

The clearance between the tape guide plate should be .011" to .016", when the retaining lid is latched and play taken up in a direction for minimum clearance. To adjust, remove or add shims between the tape fingers and retaining lid plate. The fingers may be bent if necessary.

f. TAPE RETAINING LID PLATE (Figure 18)

Place a piece of chadless tape in the tape guide, (engage the feed holes on the pins of the feed roll and feed wheel) and close lid. The edges of the plate should be parallel to the shoulders of the tape guide and when the feed roll is rotated the retaining lid plate should not interfere with the lids of the chadless tape when the lids are raised. The feed wheel should be centered in the slot of the tape finger so that chad lids are free of interference from sides of slots of the tape finger. To adjust, loosen the retaining lid plate mounting screws and position the plate and tape finger. Tighten the screws.

g. TAPE GUIDE (Figure 17)

*Apply standardized adjusting procedure.

- h. RETAINING LID LATCH SPRING (Figure 19.1)
*Apply standardized adjusting procedure.
- i. DETENT BRACKET (Figure 17)
*Apply standardized adjusting procedure.
- j. END-OF-TAPE STOP CONTACT SPRING (Figure 19.3)

*(1) With the contact operating arm on the low part of its cams (notches in cams aligned) hold contact operating arm against cam; it should require 6 to 15 grams applied to the end of the insulator of the upper contact spring to move insulator away from the arm. To adjust bend upper contact spring.

*(2) With the contact operating arm on the low part of its cams and the lower contact spring resting against its stiffener, there should be .025" to .040" gap between the contacts. To adjust, bend the lower contact spring stiffener.

*(3) With the contact operating arm on the high part of its cam, it should require 20 to 40 grams applied at the contact points of the lower contact spring to just open the contact points. To adjust, bend the lower contact spring.

- k. OPERATING INSTRUCTIONS - For the Torn Feed Hole Tape Stop Mechanism

Before attempting to start or restart the transmitter distributor equipped with the torn feed hole tape stop assembly, first turn the clutch magnet switch to the "OFF" position. Position new tape or reposition the torn tape beyond the damaged section so that the tape feed holes mesh with both the feed roll and the feed wheel pins in the tape guide. Latch tape lid. Then reset the mechanism by turning the reset wheel in the counterclockwise direction as far as it will go freely (when facing the switch end of the transmitter). Turn the transmitter distributor clutch switch to the "ON" position to start transmission.

5. LUBRICATION

- a. General

*For lubricating procedure refer to standardized information.

- b. Torn Feed Hole Tape Stop Mechanism

- (1) Feed roll shaft (both ends)
- (2) Feed roll ratchet (thin film of grease)
- (3) Feed roll gear (thin film of grease)
- (4) Detent lever
- (5) Detent roller
- (6) Idler gear shaft (both sides of gear and at the end of shaft)
- (7) Feed wheel (both sides)
- (8) Feed wheel spring clutch

- (9) Feed wheel
- (10) Feed wheel shaft (both ends of block)
- (11) Reset wheel (both sides)
- (12) Reset wheel spring clutch
- (13) Contact operating arm cam and gear (thin film of grease)
- (14) Contact operating arm shaft (both sides of block)
- (15) Retaining lid (each end)
- (16) Retaining lid latch

* * *

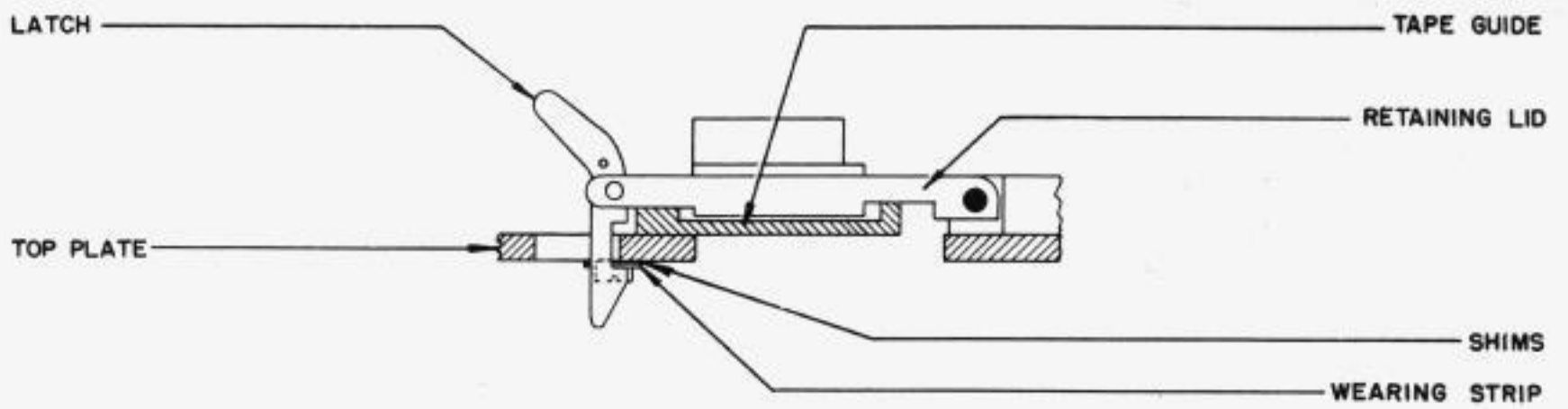

FIGURE 19.1

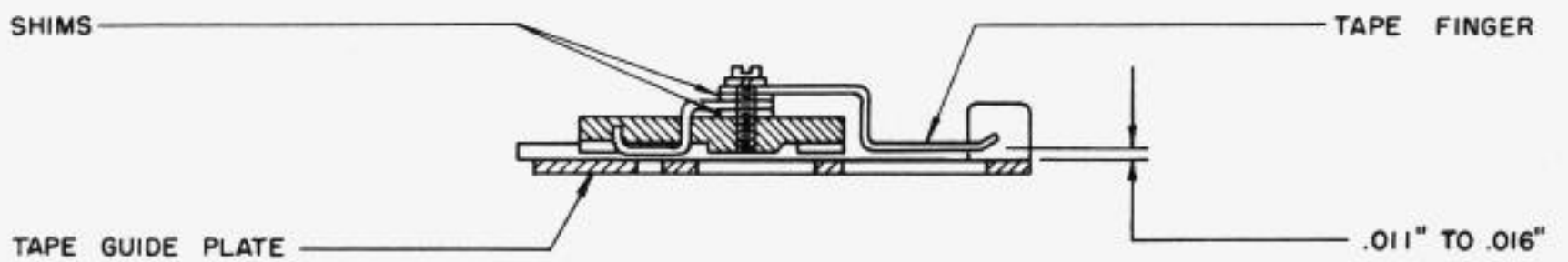

FIGURE 19.2

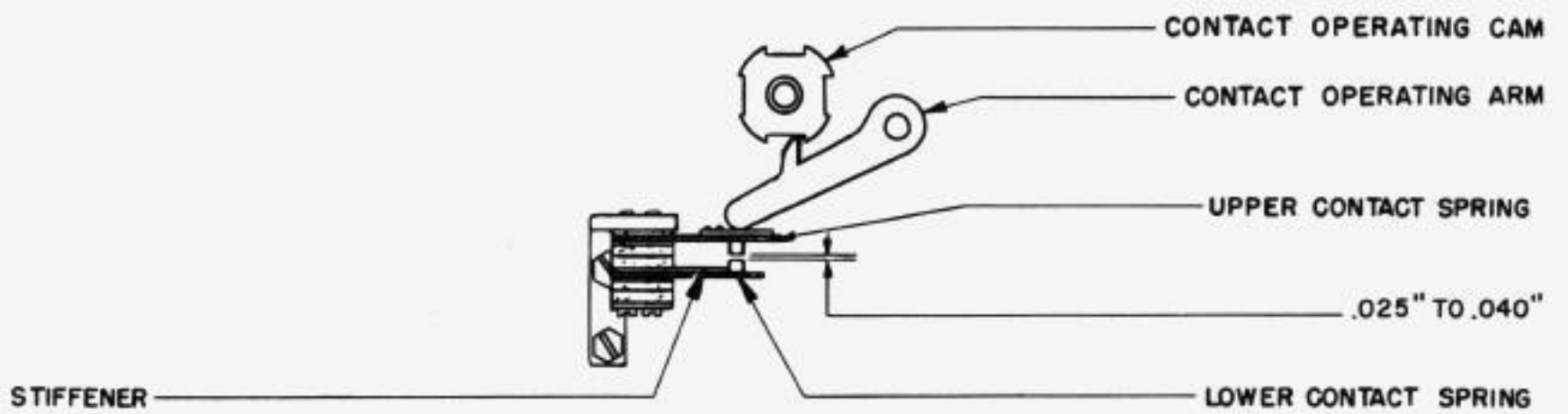
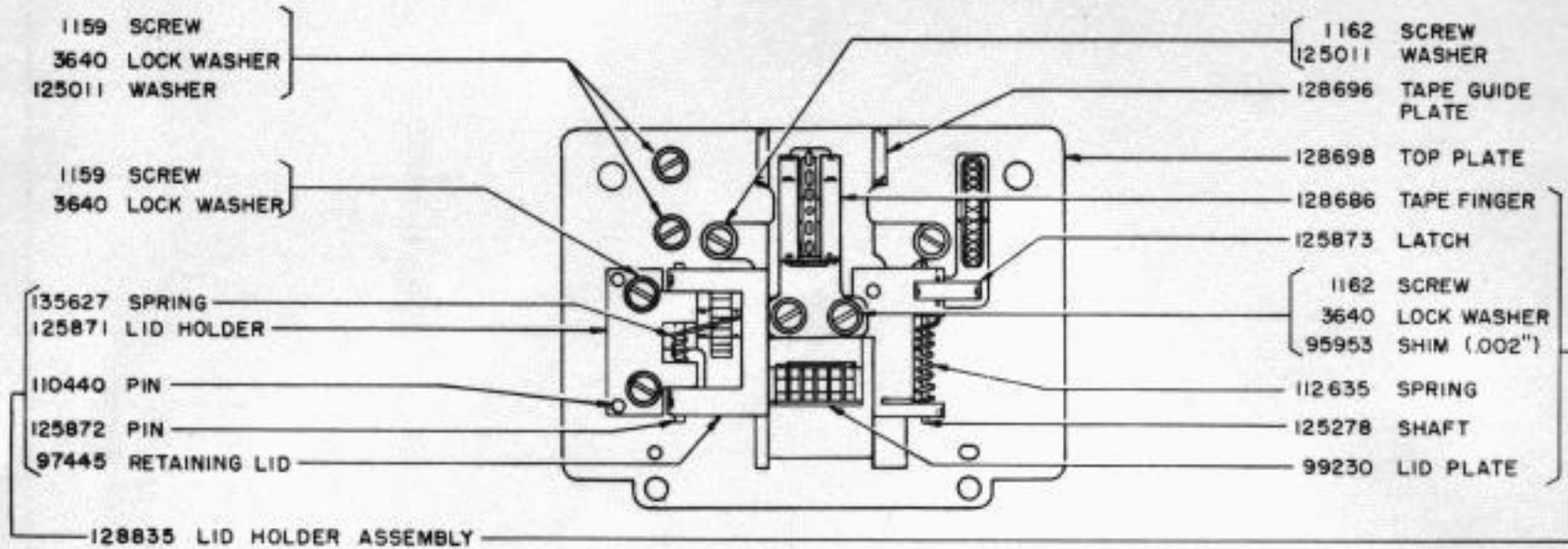
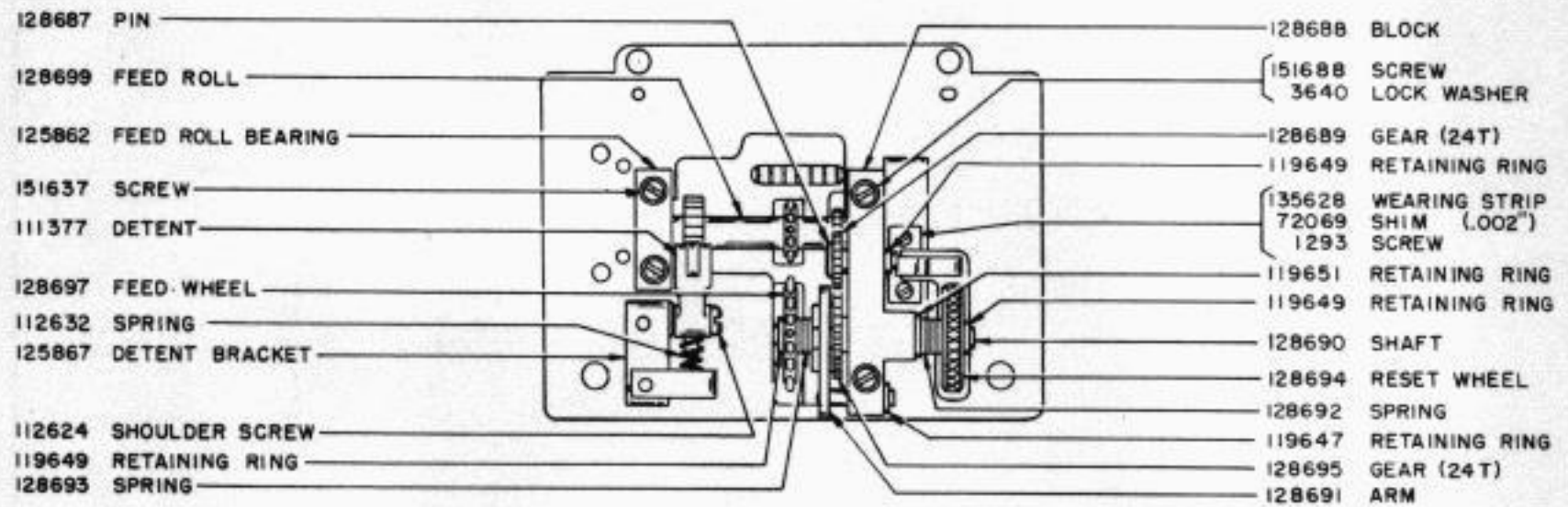

FIGURE 19.3



TOP VIEW



BOTTOM VIEW

128700 TORN FEED HOLE TAPE STOP ASSEMBLY