

28 TYPING UNIT

LUBRICATION

CONTENTS	PAGE	CONTENTS	PAGE
1. GENERAL	2	Vertical positioning mechanism (left side)	11
2. BASIC UNITS	4	Vertical positioning mechanism (right side)	9
Carriage return mechanism	17	3. VARIABLE FEATURES	29
Code bar detents	7	CONTINUOUS SPACING MECHANISM	40
Code bar mechanism	6, 12	Compression spring	41
Function rocker shaft mechanism	15	Slide arm bracket	41
Horizontal positioning mechanism	18, 19	Trip mechanism	40
Letters-figures shift mechanism	20, 21	Typing unit - rear view	41
Line feed mechanism (friction feed)	26	DC MAGNET OPERATED PRINT SUPPRESSION MECHANISM	49
Line feed mechanism (sprocket feed)	27	Suppression mechanism	49
Main shaft (clutches, gears, etc.)	23, 24	FORM ALIGNMENT SWITCH MECHANISM	48
Main shaft mechanism	23	Operating mechanism	48
Oscillating mechanism	21, 22	FORM FEED-OUT MECHANISM	50
Paper feed mechanism (front view)	7	Feed-out bail	50
Paper guide mechanism (sprocket feed)	28	HORIZONTAL TABULATOR MECHANISM (EARLIER DESIGN)	29
Paper spindle latch mechanism	26	Operating lever mechanism	30
Printing mechanism	4, 5	Space suppression mechanism	29
Ribbon feed mechanism (left side)	10	Spacing clutch mechanism	31
Ribbon feed mechanism (right side)	8, 9	Tabulator shaft mechanism	29
Ribbon reverse mechanism	14	Typing unit - bottom view	30
Selector mechanism	12, 13	Typing unit - front view	29
Selector cam clutch assembly	23	HORIZONTAL TABULATOR MECHANISM (LATER DESIGN)	42
Shift mechanism	15	Bail extension arm	44
Spacing drum drive mechanism (earlier design)	16	Blocking lever	43
Spacing drum drive mechanism (later design)	16	Intermediate bail	44
Spacing drum feed mechanism	17	Latch bail	44
Spacing mechanism	25	Operating lever	43, 44
Stripper blade mechanism	14		
Stunt box mechanism	14		
Track guide mechanism	17		
Type box carriage mechanism	5		
Typing unit - bottom view	22, 24		
Typing unit - front bottom view	15		
Typing unit - front view	4, 6, 18, 20		
Typing unit - left front view	7		
Typing unit - rear left end view	8		
Typing unit - rear left view	26		
Typing unit - rear top view	27		
Typing unit - rear view	13		
Typing unit - right end view	8, 11		

CONTENTS	PAGE
Slide arm	43
Spacing cut out transfer bail	44
Typing unit - bottom view	42
Typing unit - front view.	42
LETTERS-FIGURES CODE BAR SHIFT MAGNET MECHANISM.	49
Shift magnet mechanism	49
LOCAL BACK SPACE MECHANISM	35
Pawl mechanism	36
Trip mechanism	37
Typing unit - front view.	35
PAGE FEED-OUT MECHANISM.	39
Drive mechanism.	39
Typing unit - rear left end view	39
PAPER-OUT ALARM MECHANISM.	40
Operating mechanism	40
PRINT SUPPRESSION AND OFF- LINE STUNT SHIFT CONTROL MECHANISM.	50
Shift mechanism	50
REVERSE LINE FEED MECHANISM	36
Line feed mechanism	38
Trip mechanism	37
Typing unit - bottom view	36
Typing unit - rear left view	38
SELECTIVE CALLING MECHANISM	31
Clutch suppression mechanism.	35
Function reset bail mechanism.	34
Shift and stripper bail mechanisms	32
Single-double line feed mechanism	33
Stripper bail mechanism	32
Typing unit - left end view	34
Typing unit - rear view.	31
Typing unit - rear view - stunt box removed.	33
TWO COLOR RIBBON MECHANISM.	45
Oscillating lever	45
Ribbon operating mechanism	45
UNIVERSAL CONTACT (SELECTOR) MECHANISM.	48

CONTENTS	PAGE
Contact mechanism	48
UNIVERSAL CONTACT (STUNT BOX) MECHANISM	46
Operating mechanism	46
VERTICAL TABULATION AND TRANSMITTER DISTRIBUTOR CONTROL MECHANISM	47
Control mechanism	47

1. GENERAL

1.01 This section is issued to define the lubrication requirements for the 28 typing unit.

1.02 The specific lubrication instructions are divided into basic units and variable features. The basic units consist of the friction feed and sprocket feed typing units. Mechanisms which are added to a basic unit and are of an optional nature appear under variable features.

1.03 The typing unit should be lubricated as directed in this section. The points to be lubricated and the kind and quantity of lubricant to be used are indicated in the figures. Lubricate the typing unit just before placing it in service. After a few weeks of service, re-lubricate the unit to make sure that all points have received lubrication. Thereafter, the following schedule should be followed:

<u>Operating Speed (WPM)</u>	<u>Lubrication Interval</u>
60	3000 hr or 1 yr*
75	2400 hr or 9 mo*
100	1500 hr or 6 mo*

*Whichever occurs first.

1.04 Use KS-7470 oil at all locations where the use of oil is indicated. Use KS-7471 grease on all surfaces where grease is indicated.

1.05 All spring wicks and felt oilers should be saturated. The friction surfaces of all moving parts should be thoroughly lubricated. However, overlubrication, which will permit oil or grease to drip or be thrown on other parts, should be avoided.

CAUTION: SPECIAL CARE MUST BE TAKEN TO PREVENT ANY OIL OR GREASE FROM GETTING BETWEEN THE SELECTOR ARMATURE AND ITS MAGNET POLE FACES. KEEP ALL ELECTRICAL CONTACTS FREE OF OIL AND GREASE.

- 1.06 Apply a thick film of grease to all gears and the spacing clutch reset cam plate.
- 1.07 Apply oil to all cams, including the camming surfaces of each clutch disc.
- 1.08 The photographs show the paragraph numbers referring to particular line drawings of mechanisms and where these mechanisms are located on the unit. Parts in the line drawings are shown in an upright position unless otherwise specified.

Note: References made to left or right, top or bottom, and front or rear apply to the typing unit in its normal operating position as viewed by the operator facing the unit.

- 1.09 The following list of symbols apply to the specific lubrication instructions given in each paragraph.

- O Apply 1 drop of oil.
- O2 Apply 2 drops of oil.
- O3 Apply 3 drops of oil, etc.
- G Apply thin film of grease.
- SAT Saturate (felt oilers, washers, wicks) with oil.

- 1.10 During each lubrication period, check the following items. Requirements and adjustments are given in Section 573-115-700.

- (1) Printing Carriage Position
- (2) Printing Hammer Bearing Stud
- (3) Printing Track
- (4) Printing Hammer Stop Bracket (Also see Note 2, Par. 2.48, 573-115-700 which refers to Printing Hammer Operating Bail Spring Bracket Position.)
- (5) Carriage Draw Wire Rope
- (6) Dashpot Vent Screw (Check dashpot transfer slide for freeness.)

2. BASIC UNITS

2.01 Typing Unit - Front View

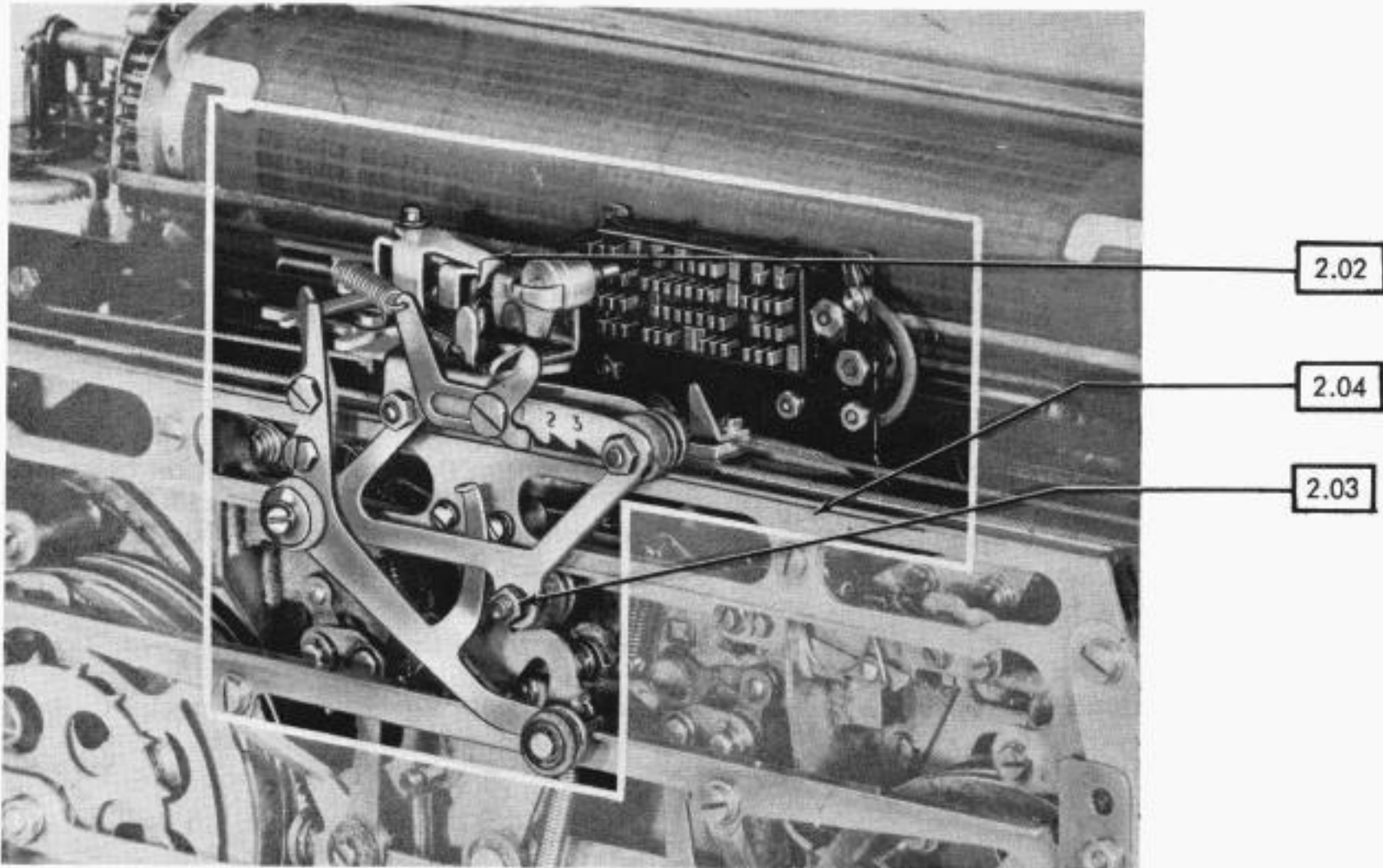

2.02 Printing Mechanism

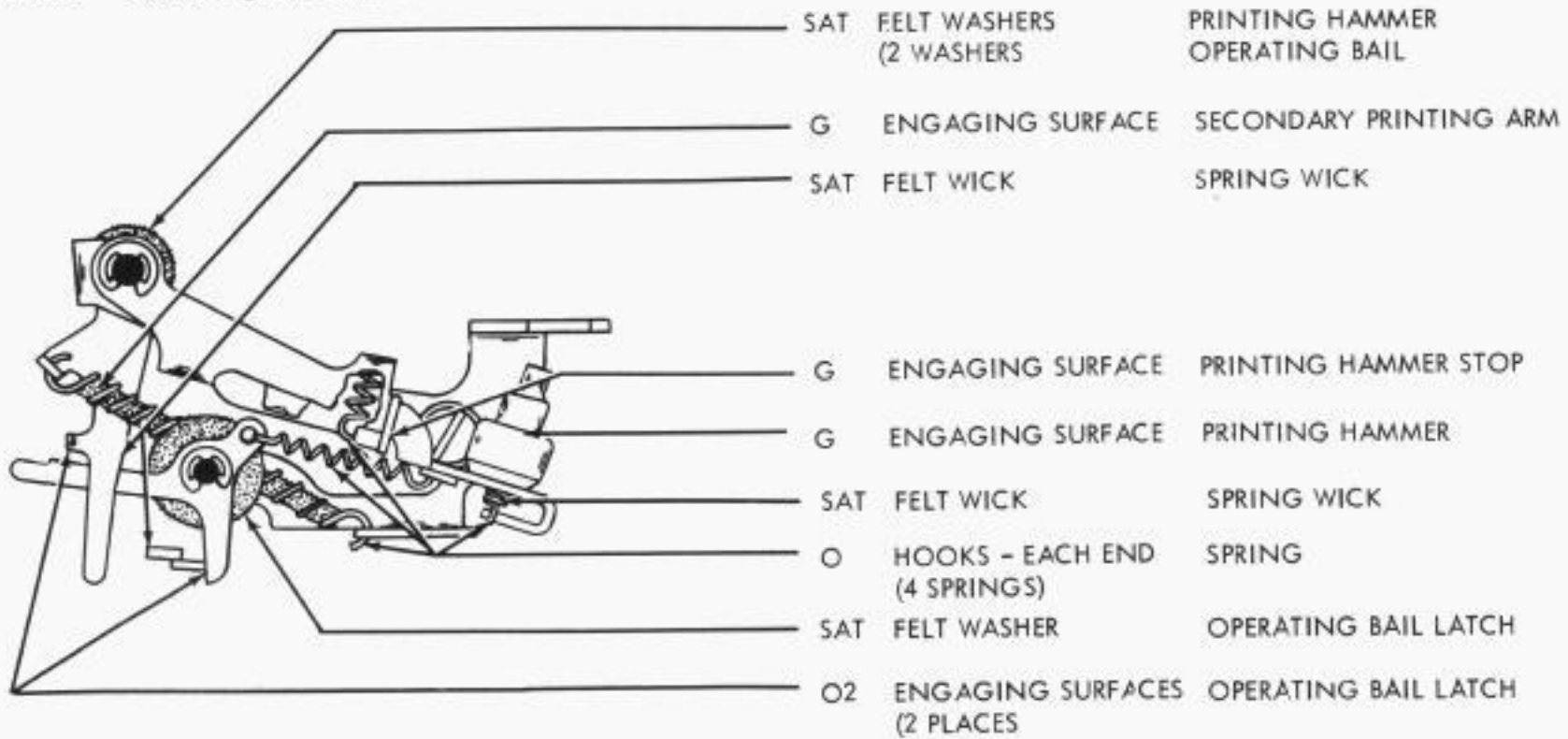

2.03 Printing Mechanism (Cont'd)

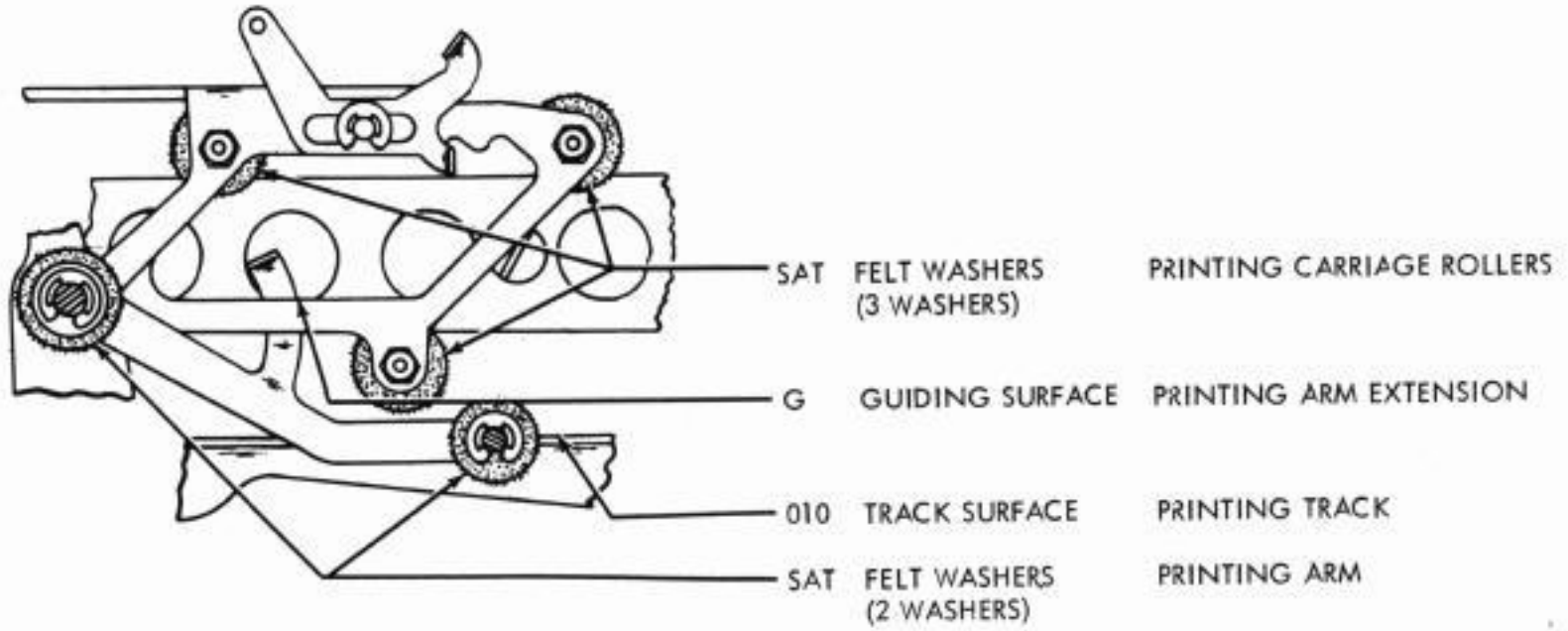

2.04 Type Box Carriage Mechanism

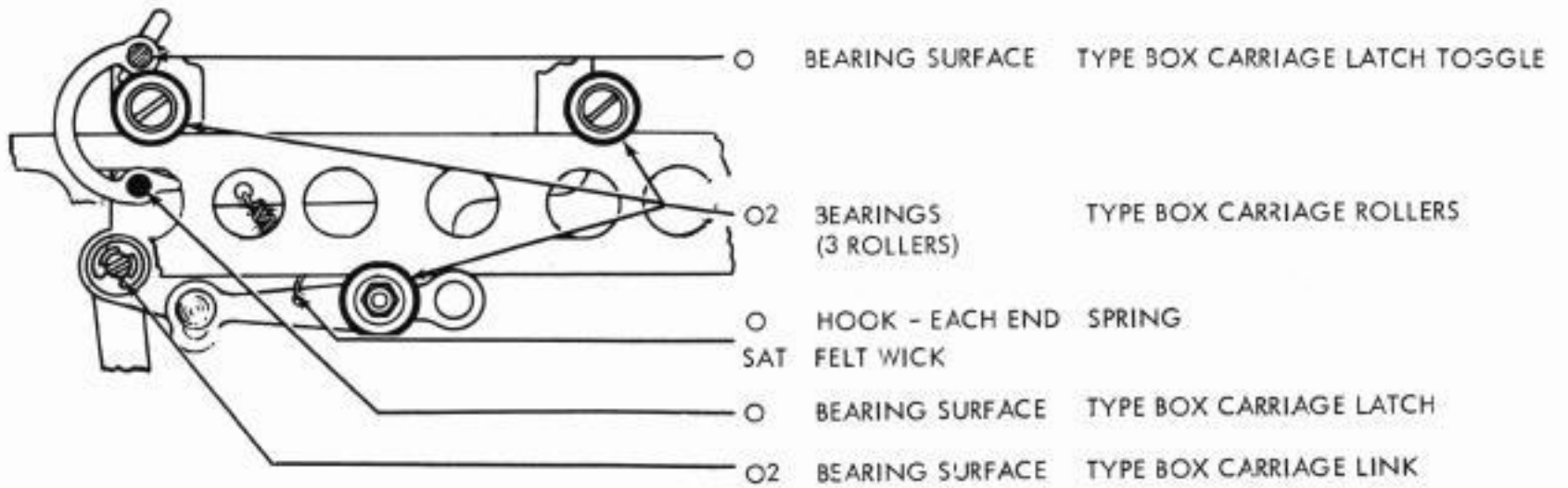

2.05 Typing Unit - Front View

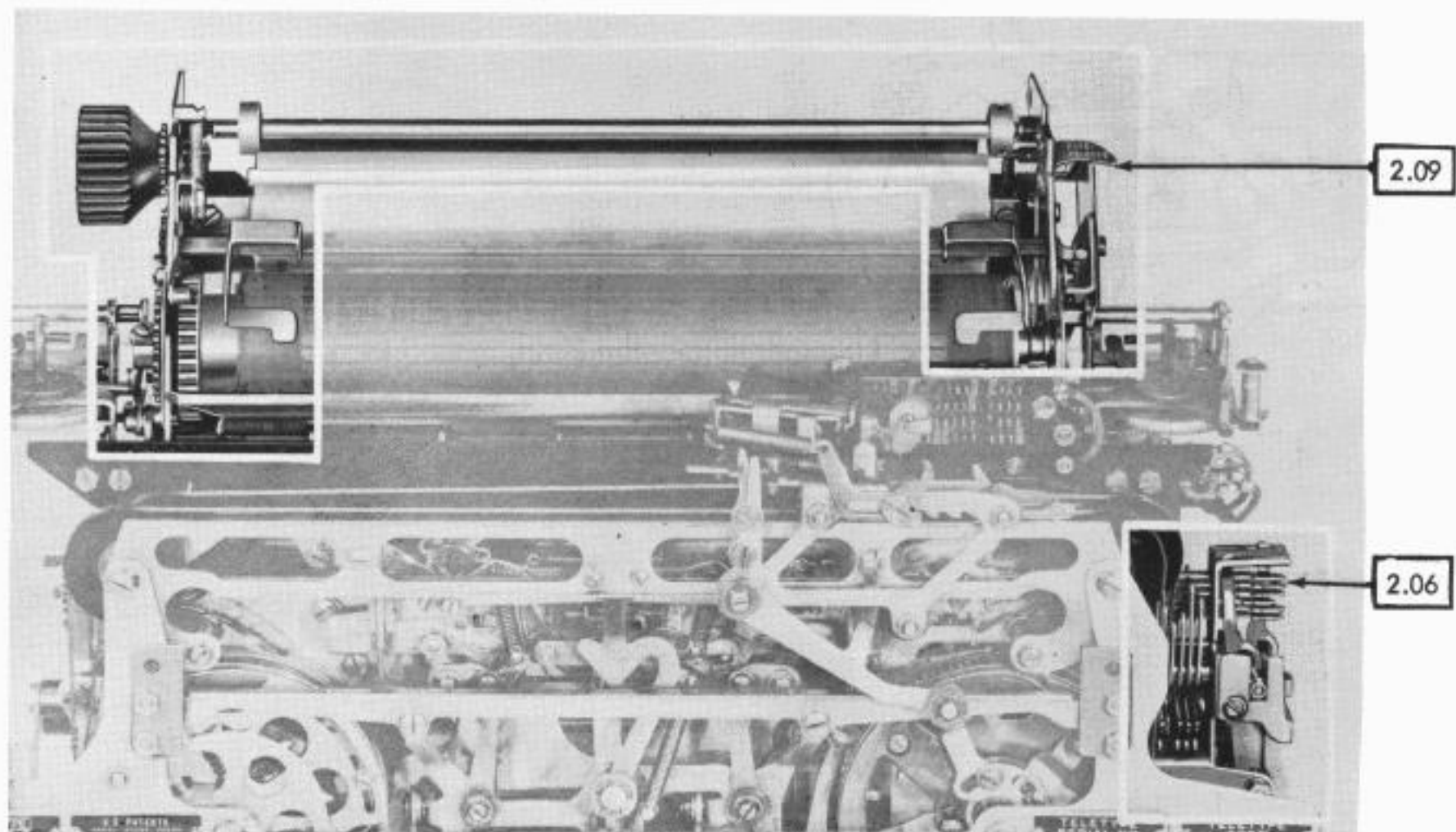

2.06 Codebar Mechanism

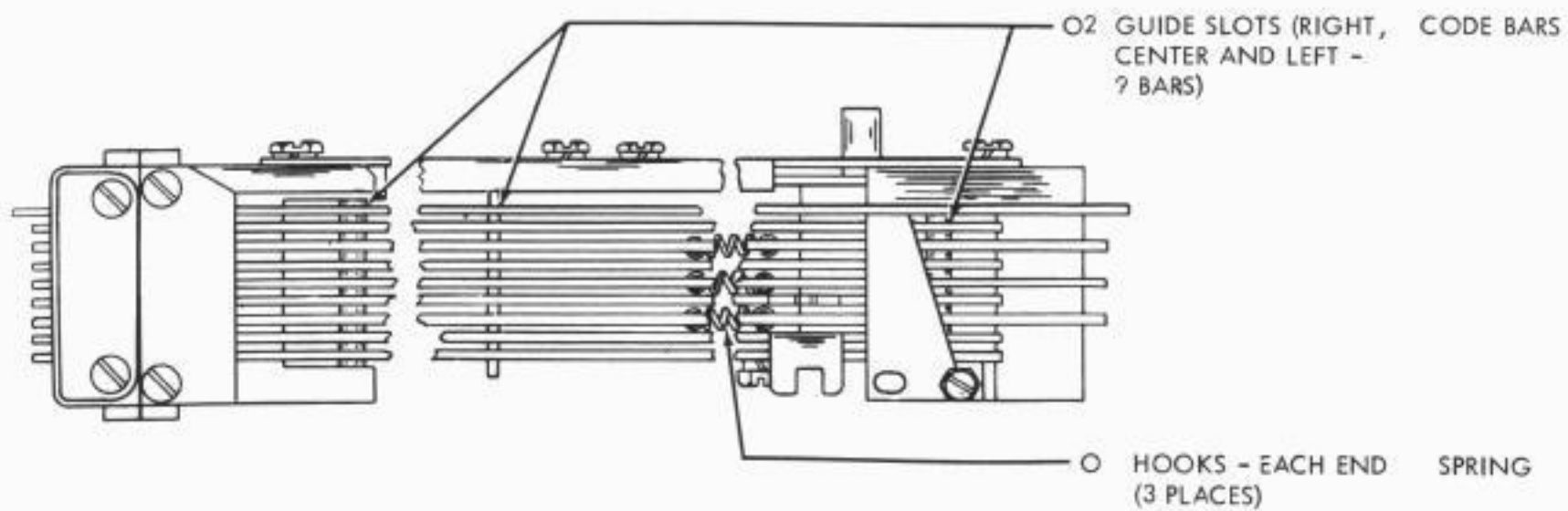

2.07 Typing Unit - Left Front View

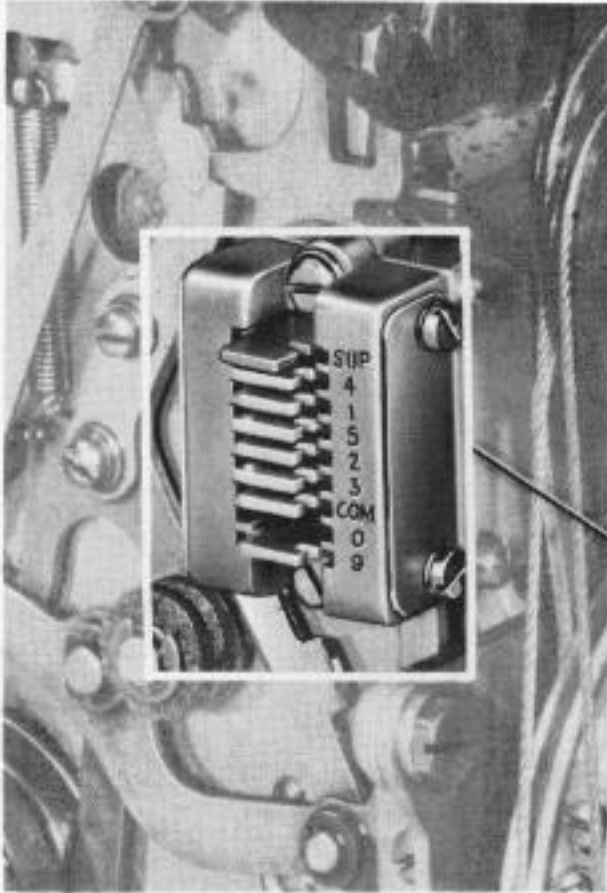

2.08 Codebar Detents

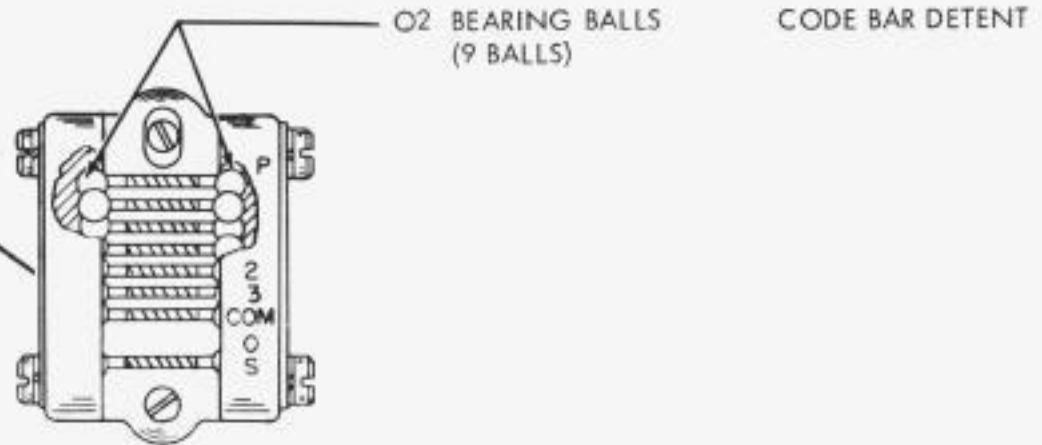

2.09 Paper Feed Mechanism - Front View

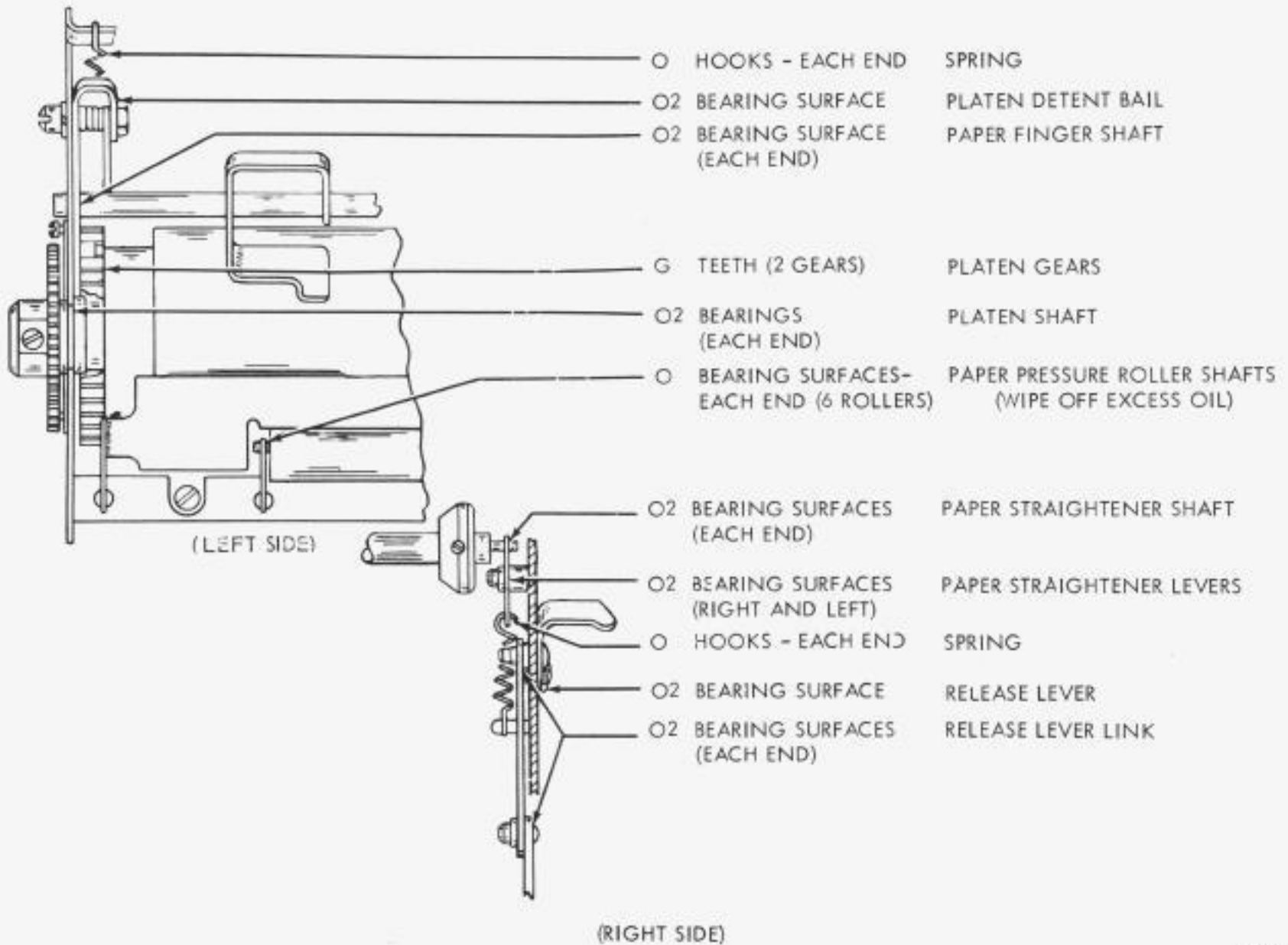

2.10 Typing Unit - Rear Left End View

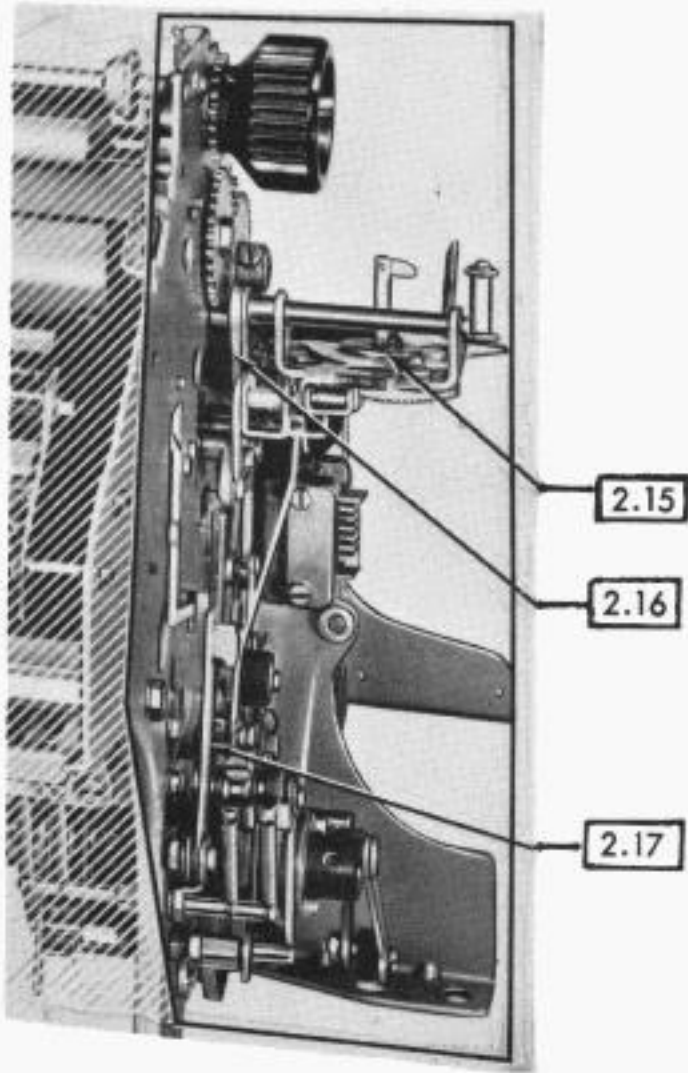

2.11 Typing Unit - Right End View

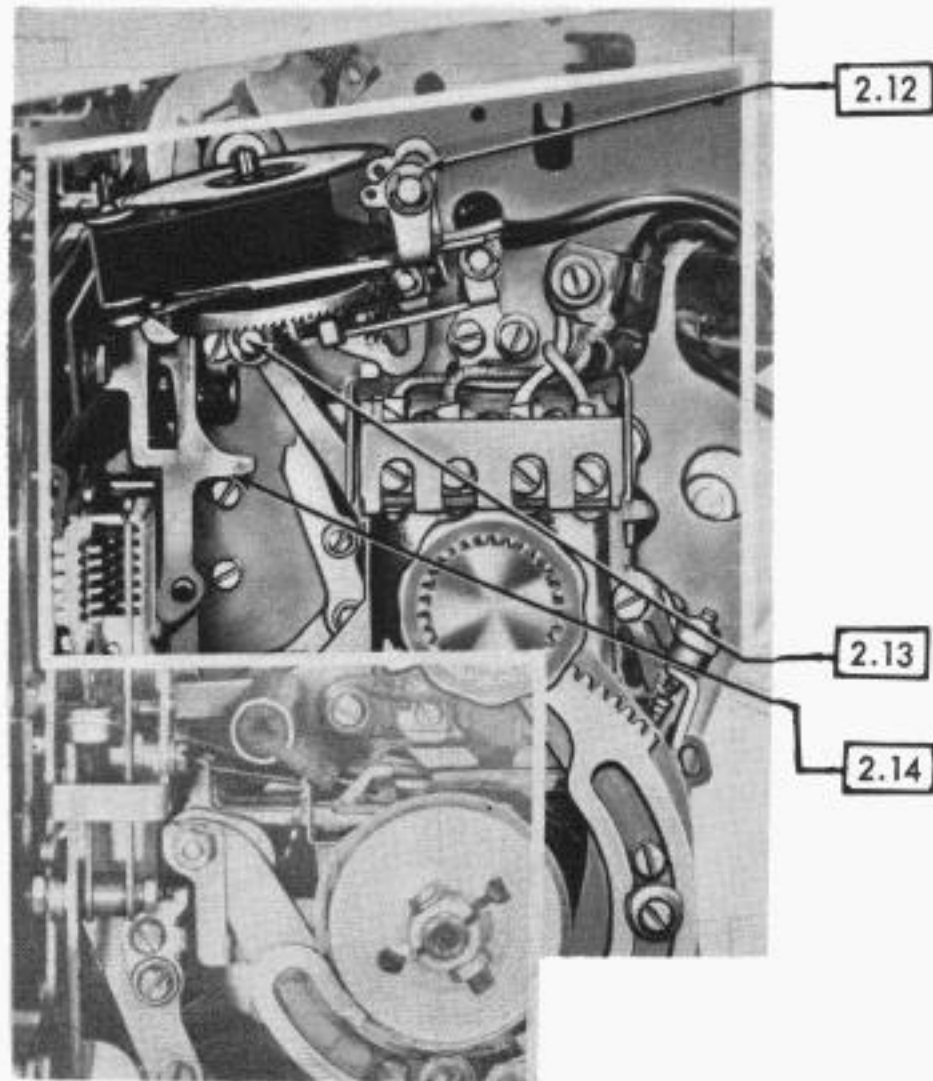

2.12 Ribbon Feed Mechanism - Right Side

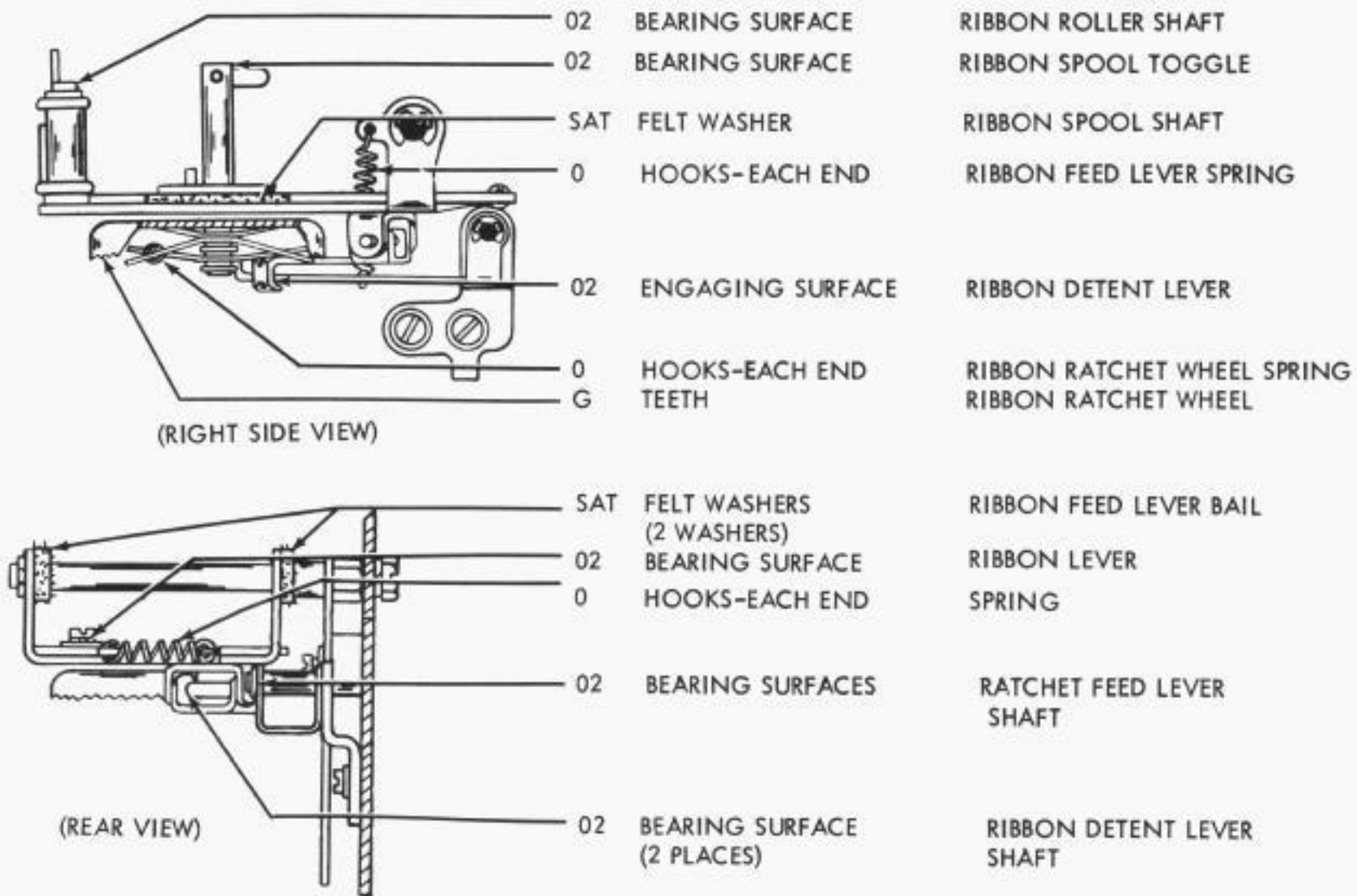

2.13 Ribbon Feed Mechanism - Right Side (Cont'd)



2.14 Vertical Positioning Mechanism - Right Side

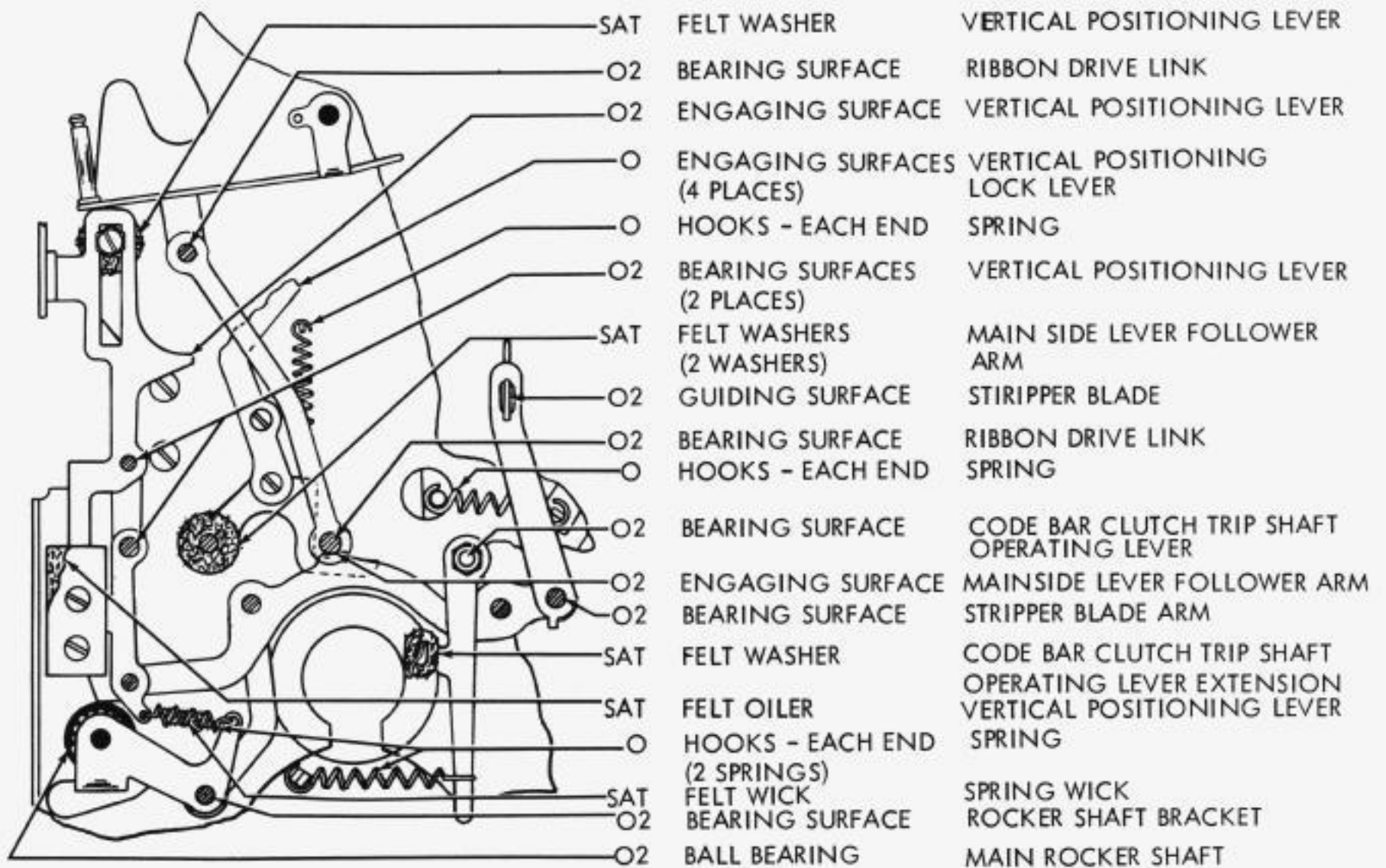

2.15 Ribbon Feed Mechanism - Left Side

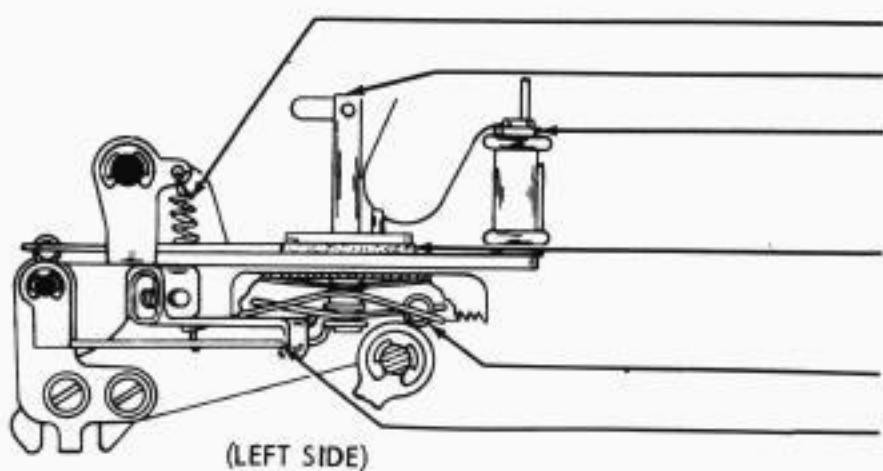

- 0 HOOKS—EACH END SPRING
- 0 BEARING SURFACE RIBBON SPOOL SHAFT
- 02 BEARING SURFACE RIBBON ROLLER SHAFT
- SAT FELT WASHER RIBBON SPOOL SHAFT
- 0 HOOKS - EACH END SPRING
- 02 ENGAGING SURFACE RIBBON DETENT LEVER

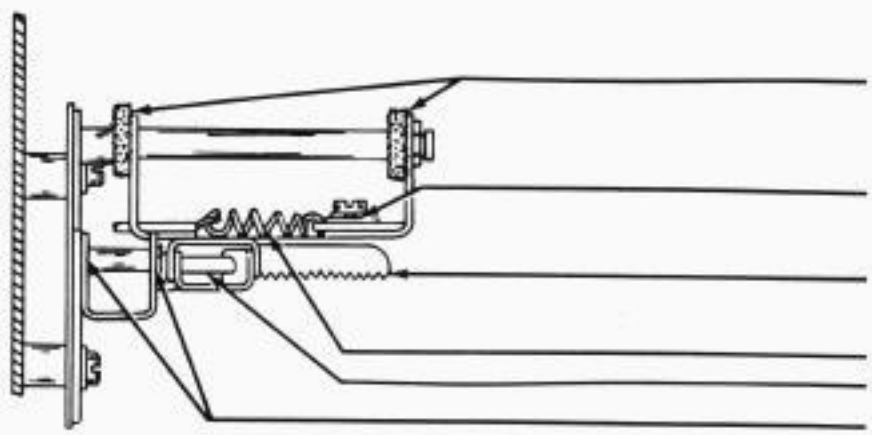

- SAT FELT WASHERS (2 WASHERS) RIBBON FEED LEVER BAIL
- 02 BEARING SURFACE RIBBON REVERSE LEVER
- G TEETH RIBBON RATCHET WHEEL
- 0 HOOKS - EACH END SPRING
- 02 ENGAGING SURFACE RIBBON DETENT LEVER SHAFT
- 02 BEARING SURFACES (2 PLACES) RATCHET FEED LEVER SHAFT

2.16 Ribbon Feed Mechanism - Left Side (Cont'd)

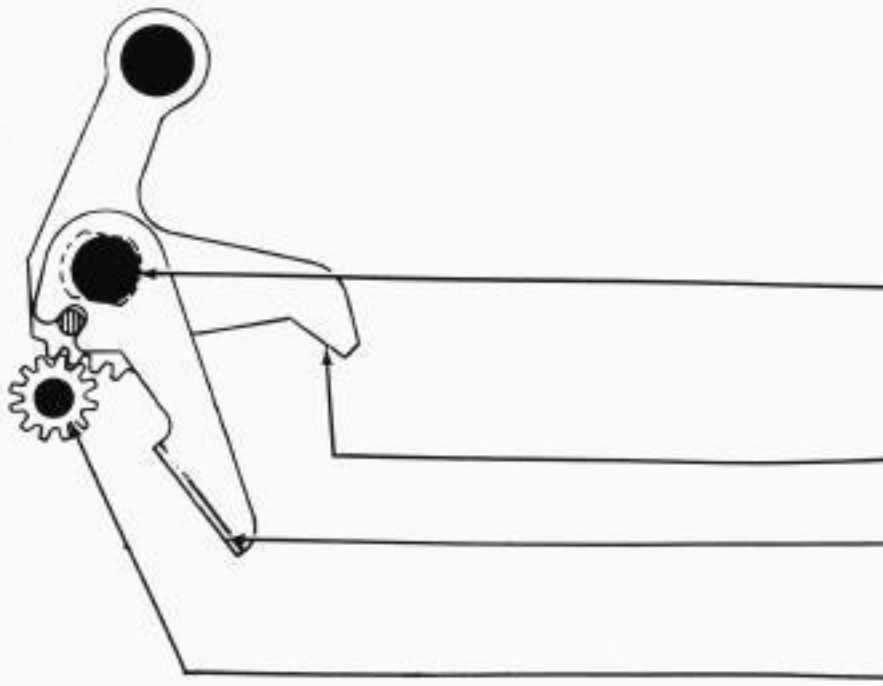

- 02 BEARING SURFACE RIBBON REVERSE LEVER
- 02 ENGAGING SURFACE RIBBON REVERSING LEVER
- 02 ENGAGING SURFACE RIBBON REVERSE LEVER
- G TEETH RIBBON REVERSE SPUR GEAR

2.17 Vertical Positioning Mechanism - Left Side

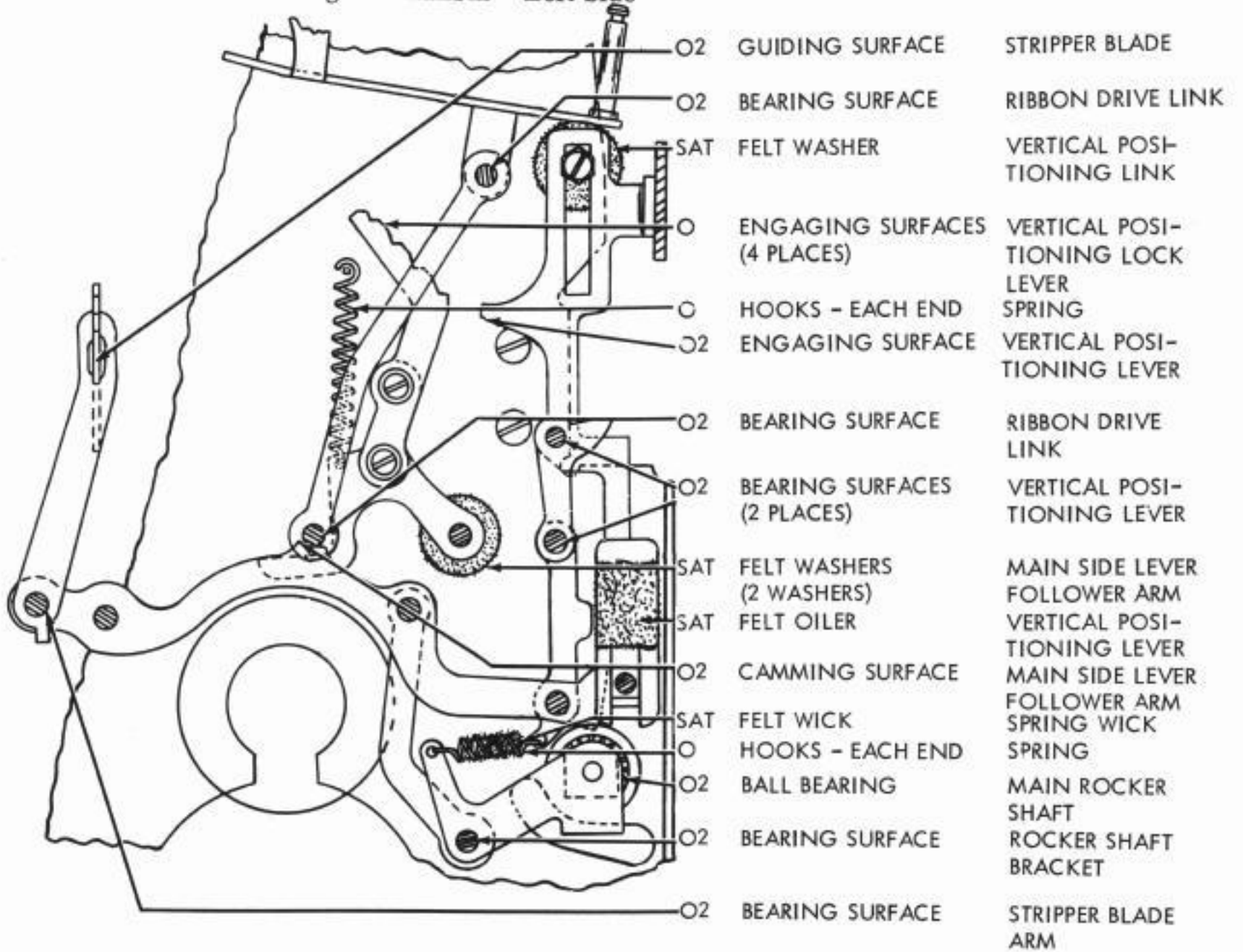

2.18 Typing Unit - Right End View

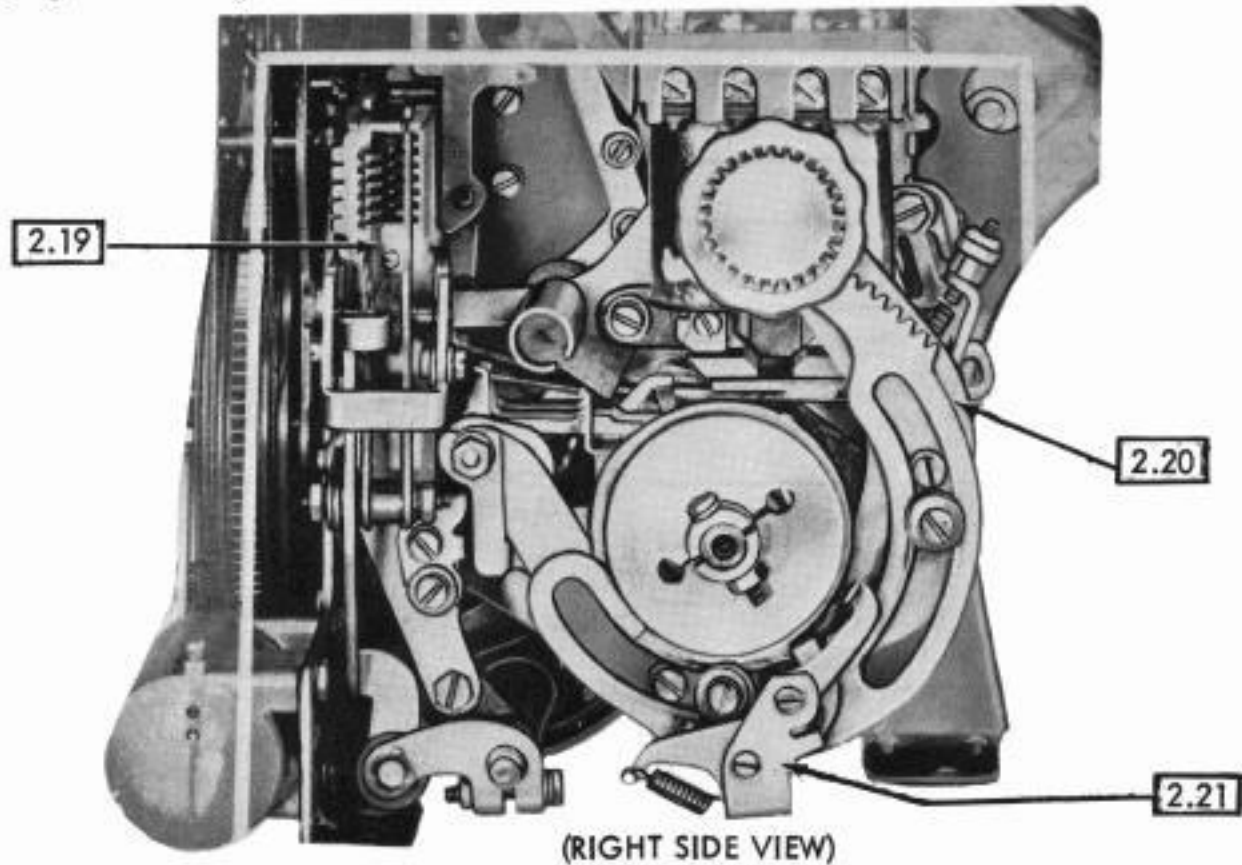

2.19 Codebar Mechanism

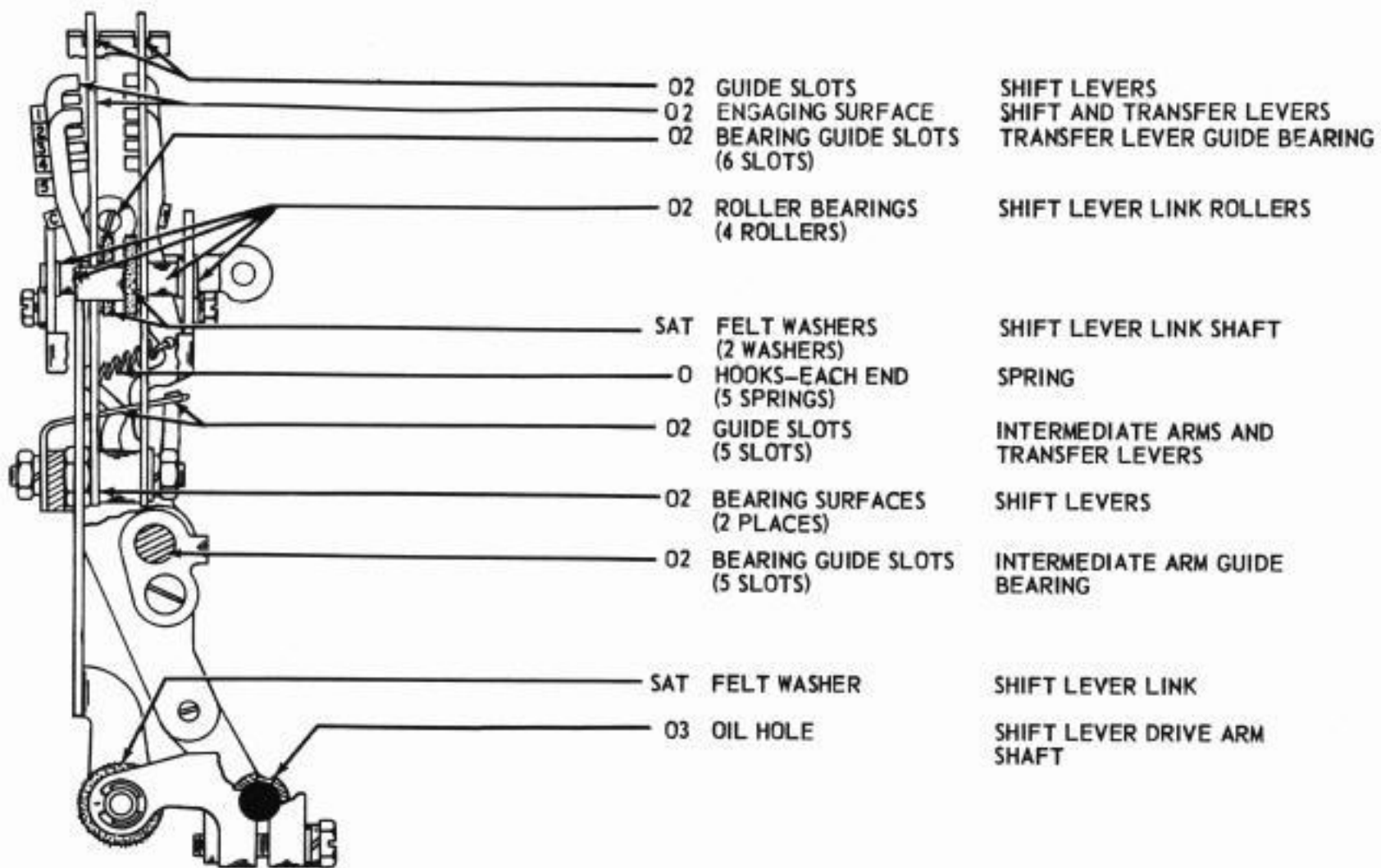

2.20 Selector Mechanism

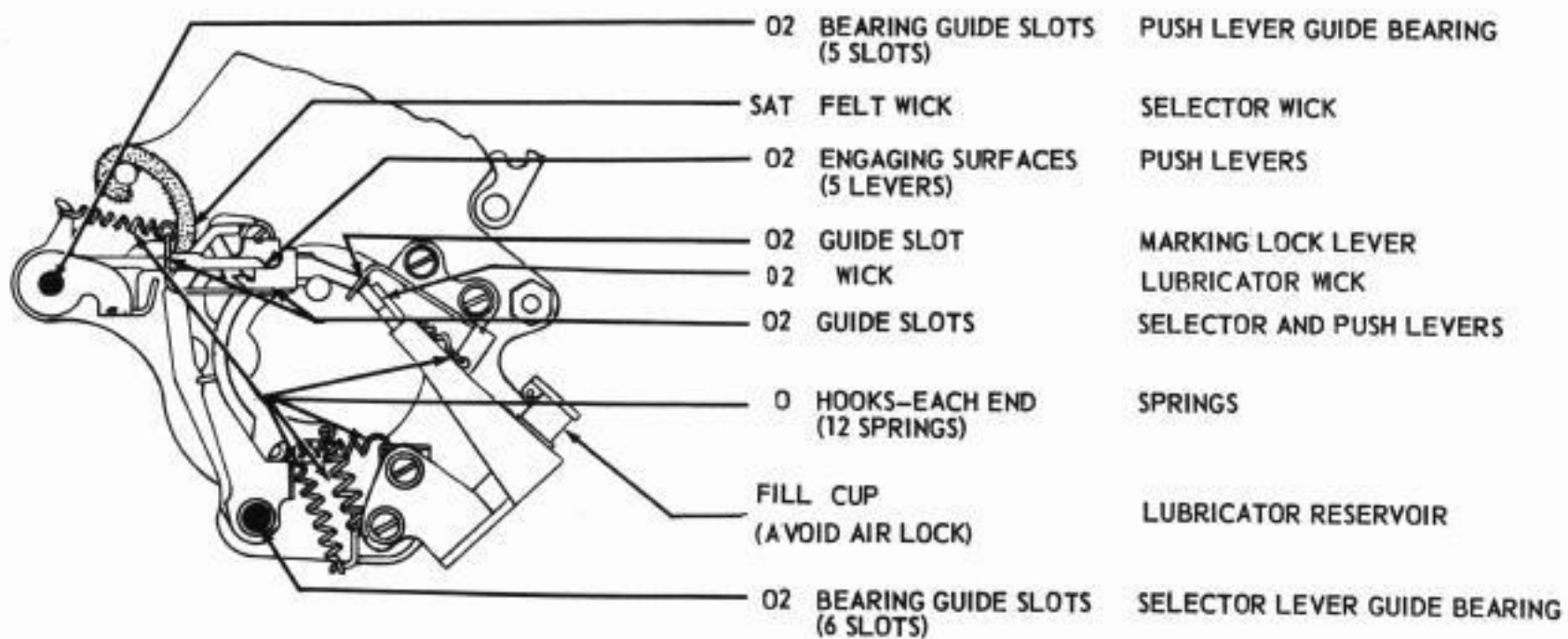

2.21 Selector Mechanism (Cont'd)

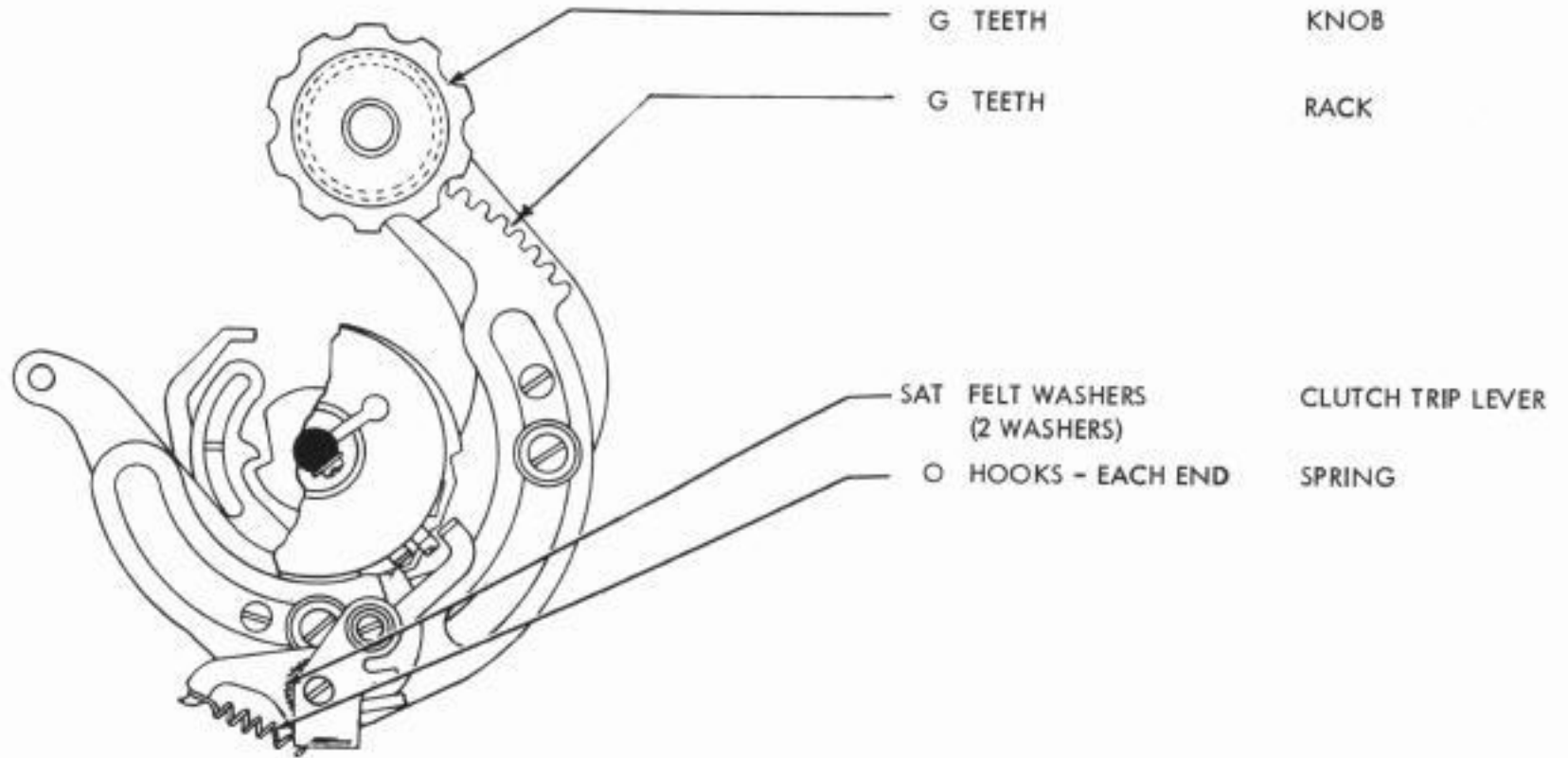

2.22 Typing Unit - Rear View

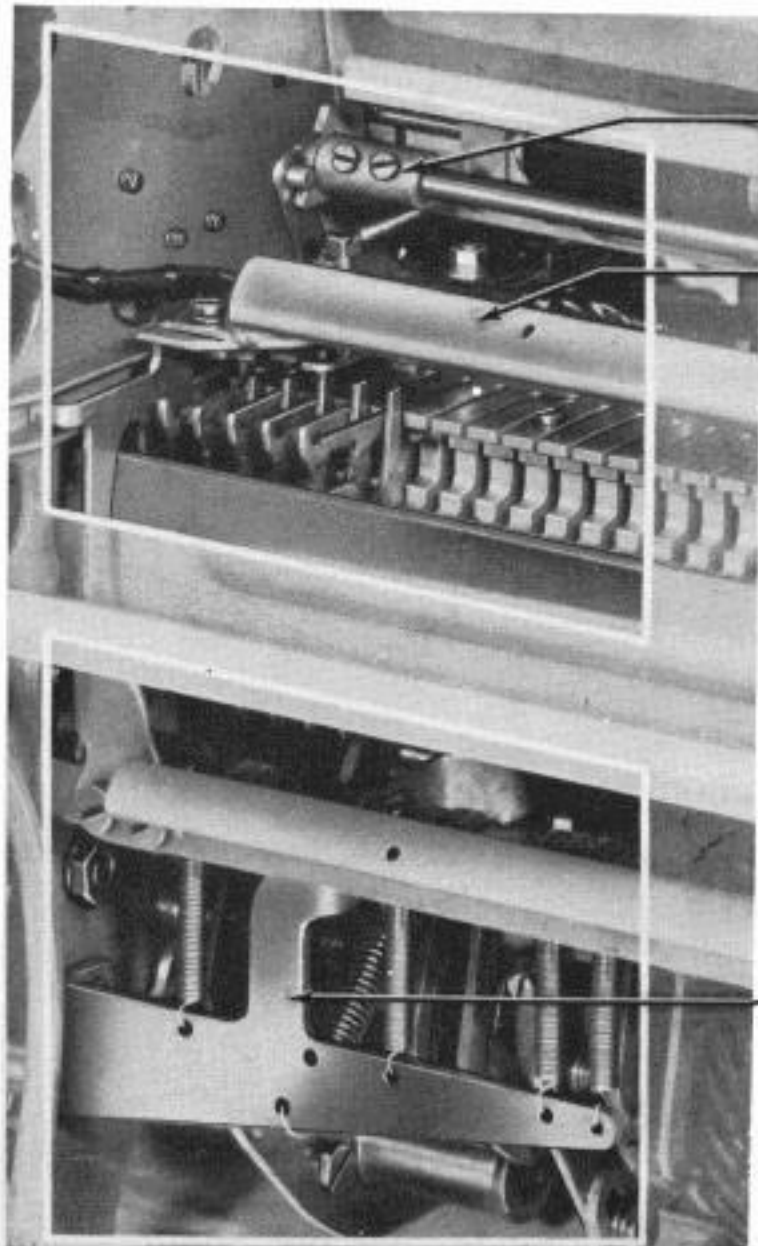

2.23 Typing Unit - Rear View

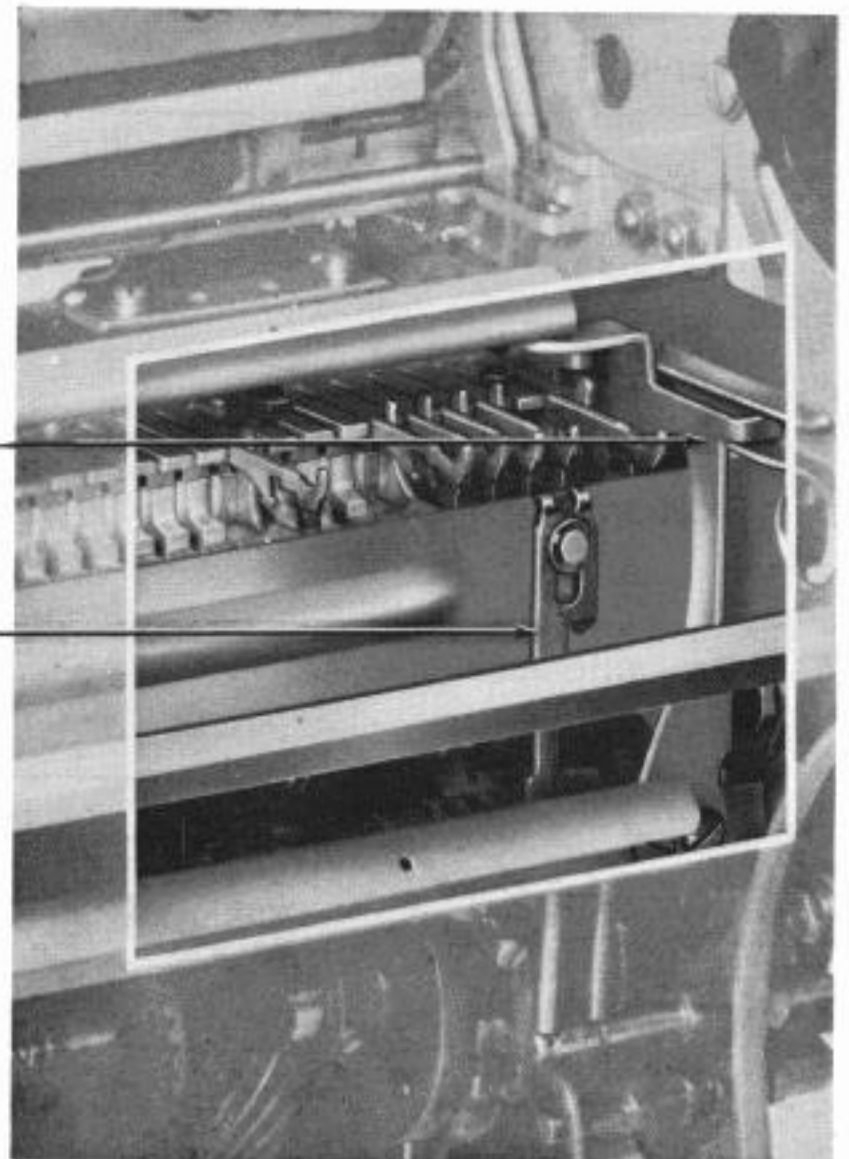

2.24 Stunt Box Mechanism

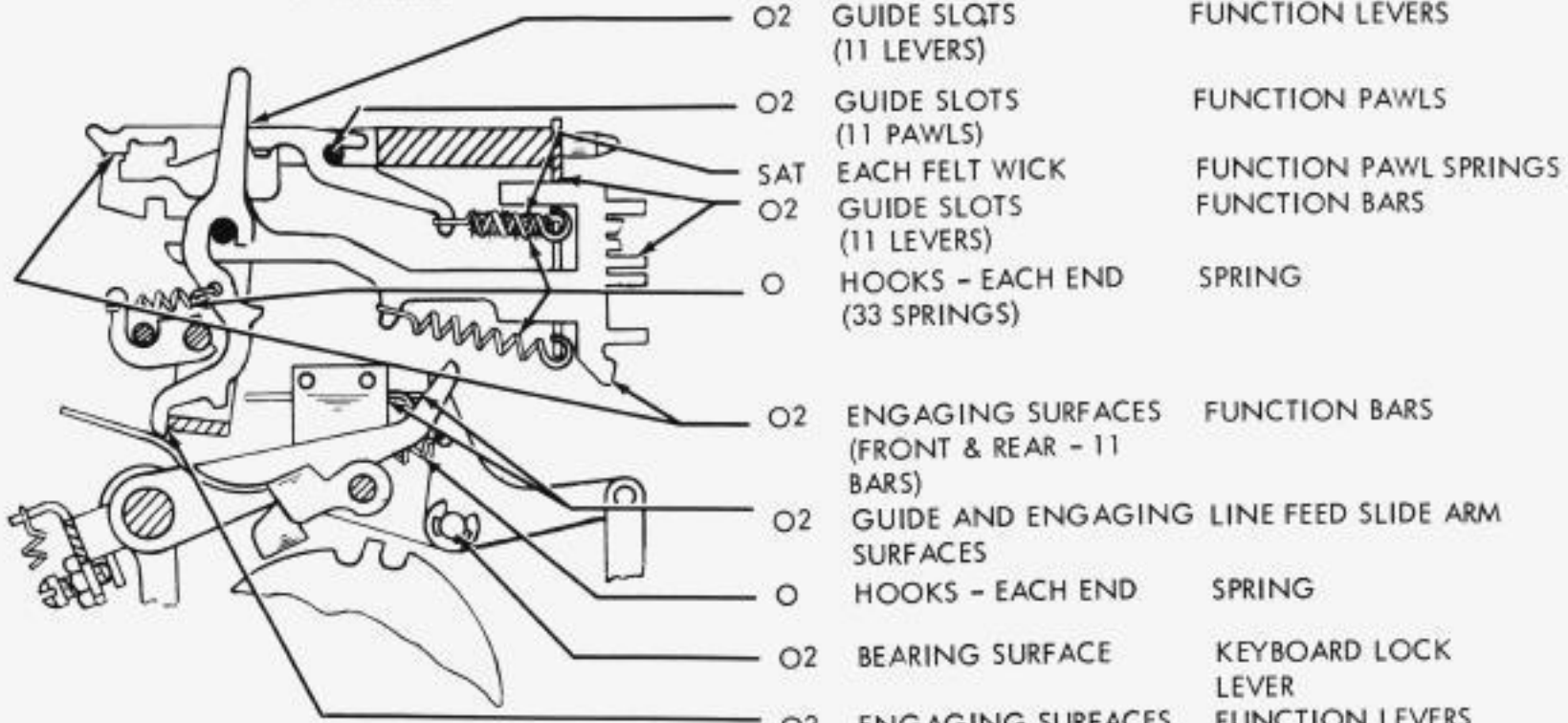

- O2 GUIDE SLOTS (11 LEVERS) FUNCTION LEVERS
- O2 GUIDE SLOTS (11 PAWLS) FUNCTION PAWLS
- SAT EACH FELT WICK FUNCTION PAWL SPRINGS
- O2 GUIDE SLOTS (11 LEVERS) FUNCTION BARS
- O HOOKS - EACH END (33 SPRINGS) SPRING
- O2 ENGAGING SURFACES (FRONT & REAR - 11 BARS) FUNCTION BARS
- O2 GUIDE AND ENGAGING SURFACES LINE FEED SLIDE ARM
- O HOOKS - EACH END SPRING
- O2 BEARING SURFACE KEYBOARD LOCK LEVER
- O2 ENGAGING SURFACES (11 LEVERS) FUNCTION LEVERS

2.25 Stripper Blade Mechanism

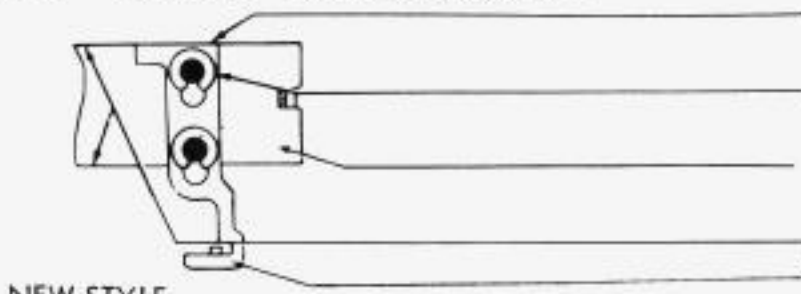

NEW STYLE

- O ENGAGING SURFACE LINE FEED STRIPPER SLIDE
- O2 GUIDE SURFACES (2 PLACES) STRIPPER SLIDE
- O2 GUIDE SURFACES (EACH END) STRIPPER BLADE
- G ENGAGING SURFACES STRIPPER BLADE
- O2 ENGAGING SURFACE STRIPPER BLADE

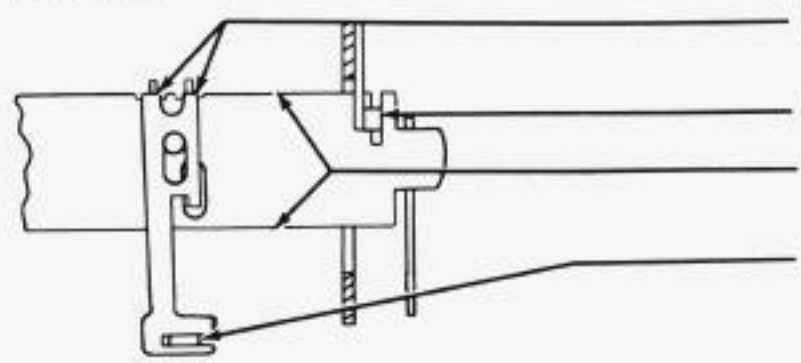

OLD STYLE

- O ENGAGING SURFACES (2 PLACES) LINE FEED FUNCTION PAWL STRIPPER
- O2 GUIDING SURFACE STRIPPER BLADE
- G UPPER AND LOWER WORKING SURFACES STRIPPER BLADE
- O2 GUIDING SURFACE STRIPPER BAIL

2.26 Ribbon Reverse Mechanism

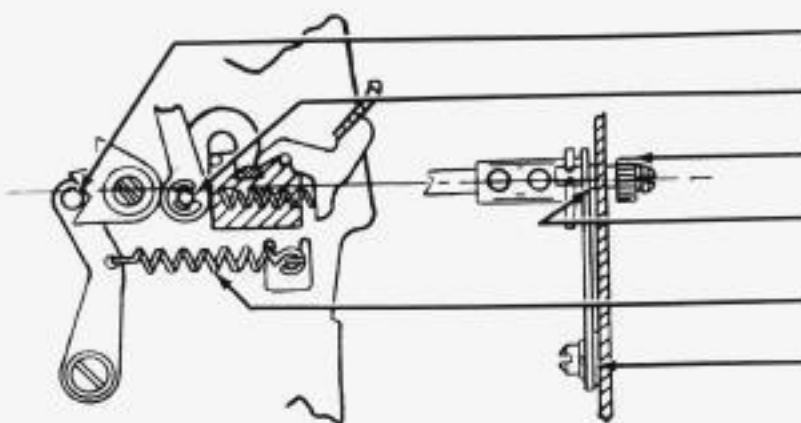

- O2 ENGAGING SURFACE RIBBON REVERSE DETENT
- O2 BEARING SURFACE PAPER RELEASE LEVER
- G TEETH RIBBON REVERSE SPUR GEAR
- O2 BEARING (RIGHT & LEFT) RIBBON REVERSE SHAFT
- O HOOKS - EACH END SPRING
- O2 BEARING SURFACE RIBBON REVERSE DETENT LEVER

2.27 Shift Mechanism

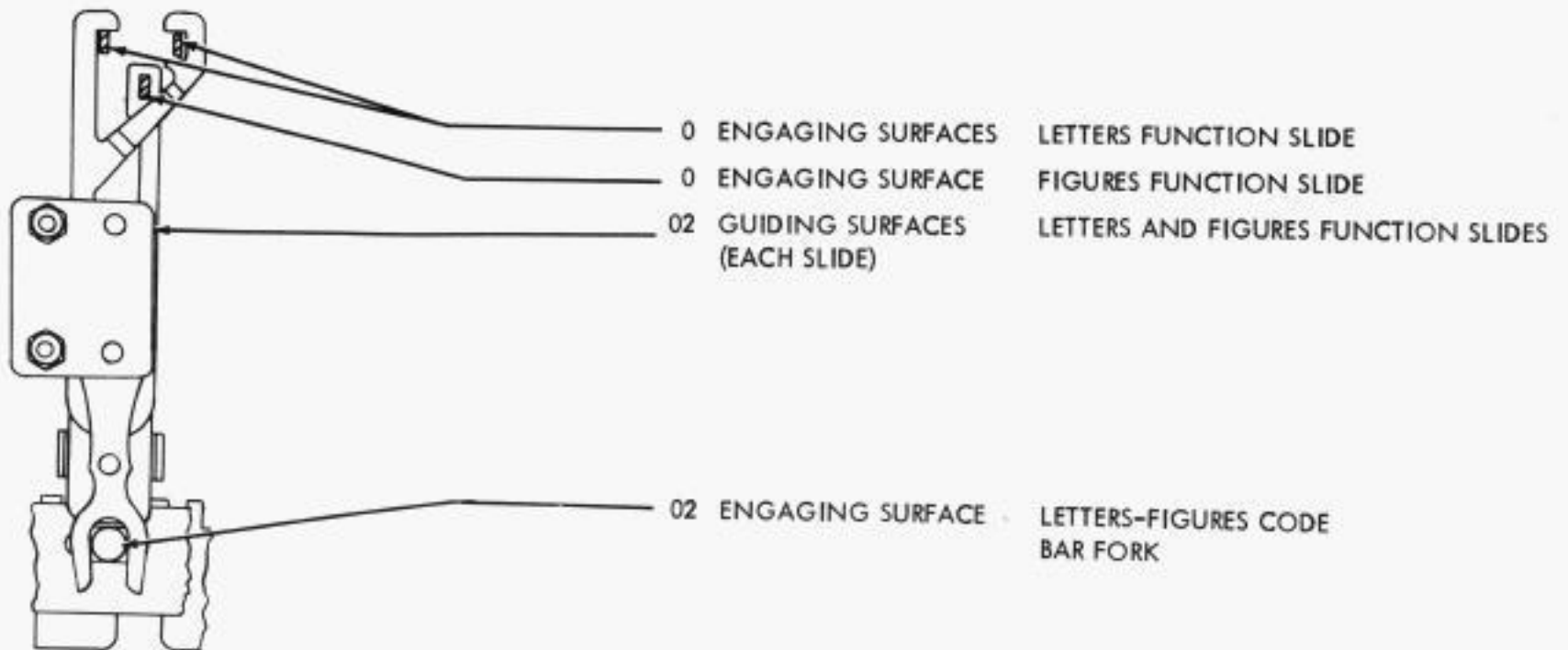

2.28 Function Rocker Shaft Mechanism

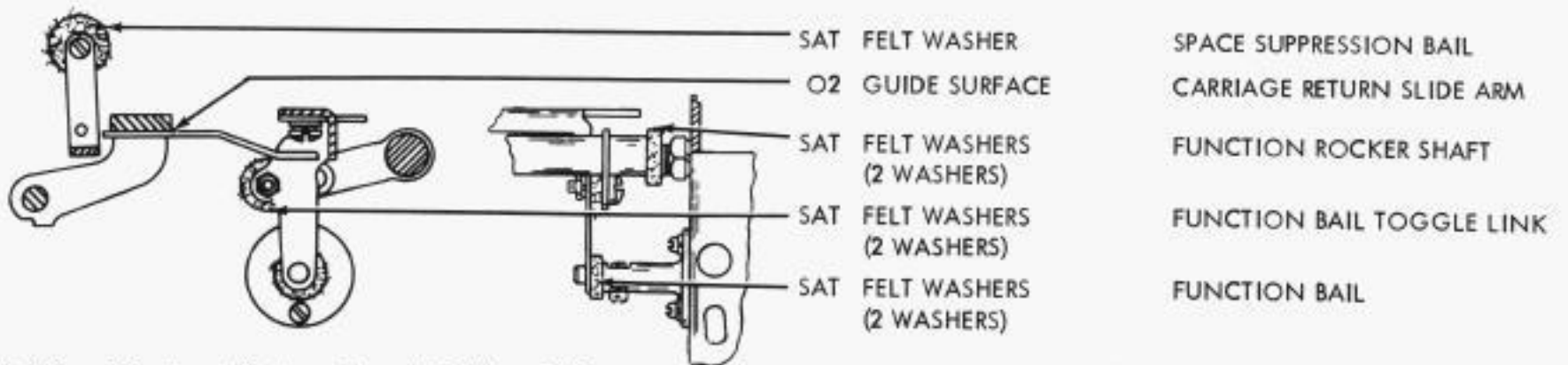

2.29 Typing Unit - Front Bottom View

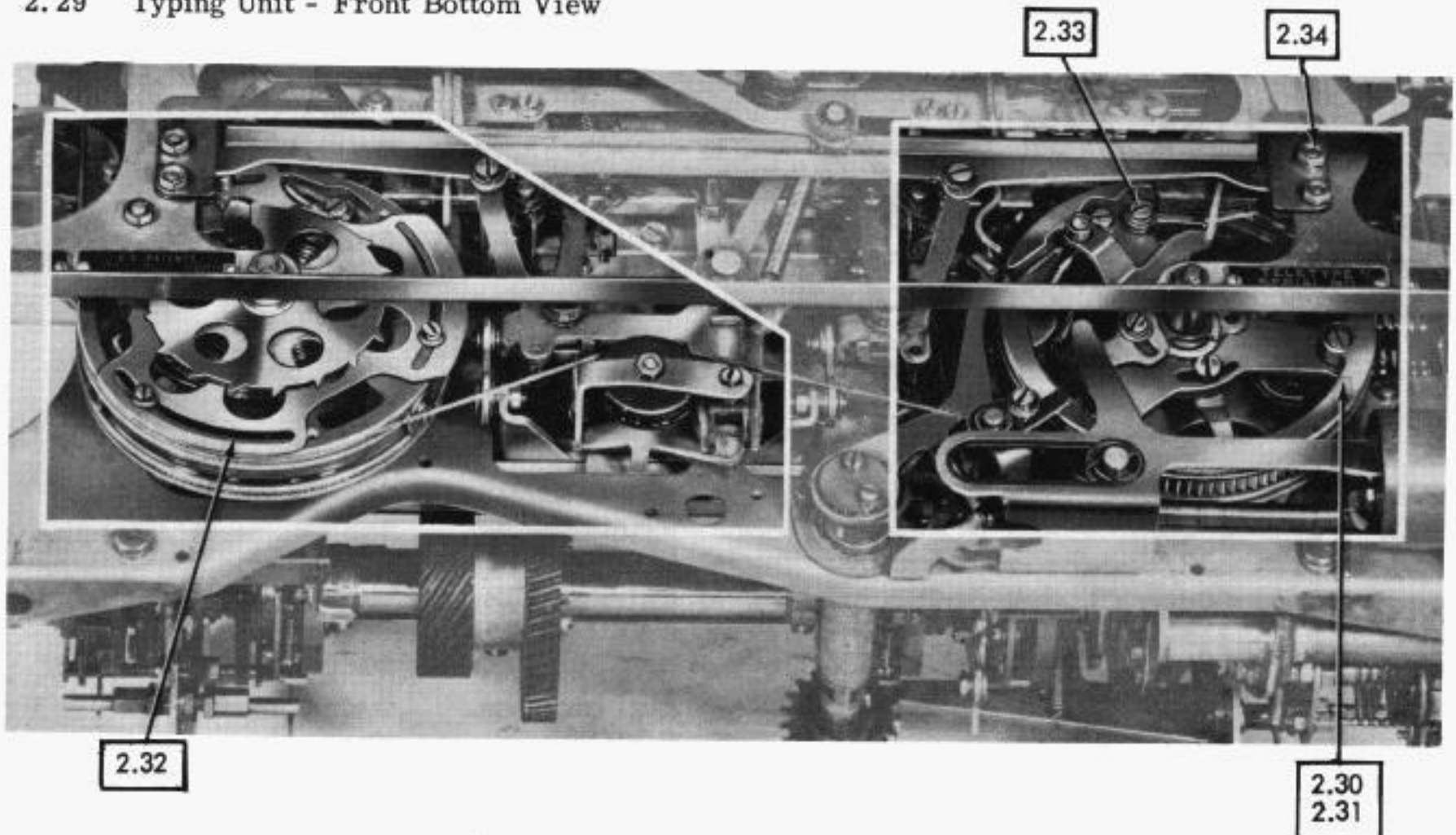

2.30 Spacing Drum Drive Mechanism - Later Design

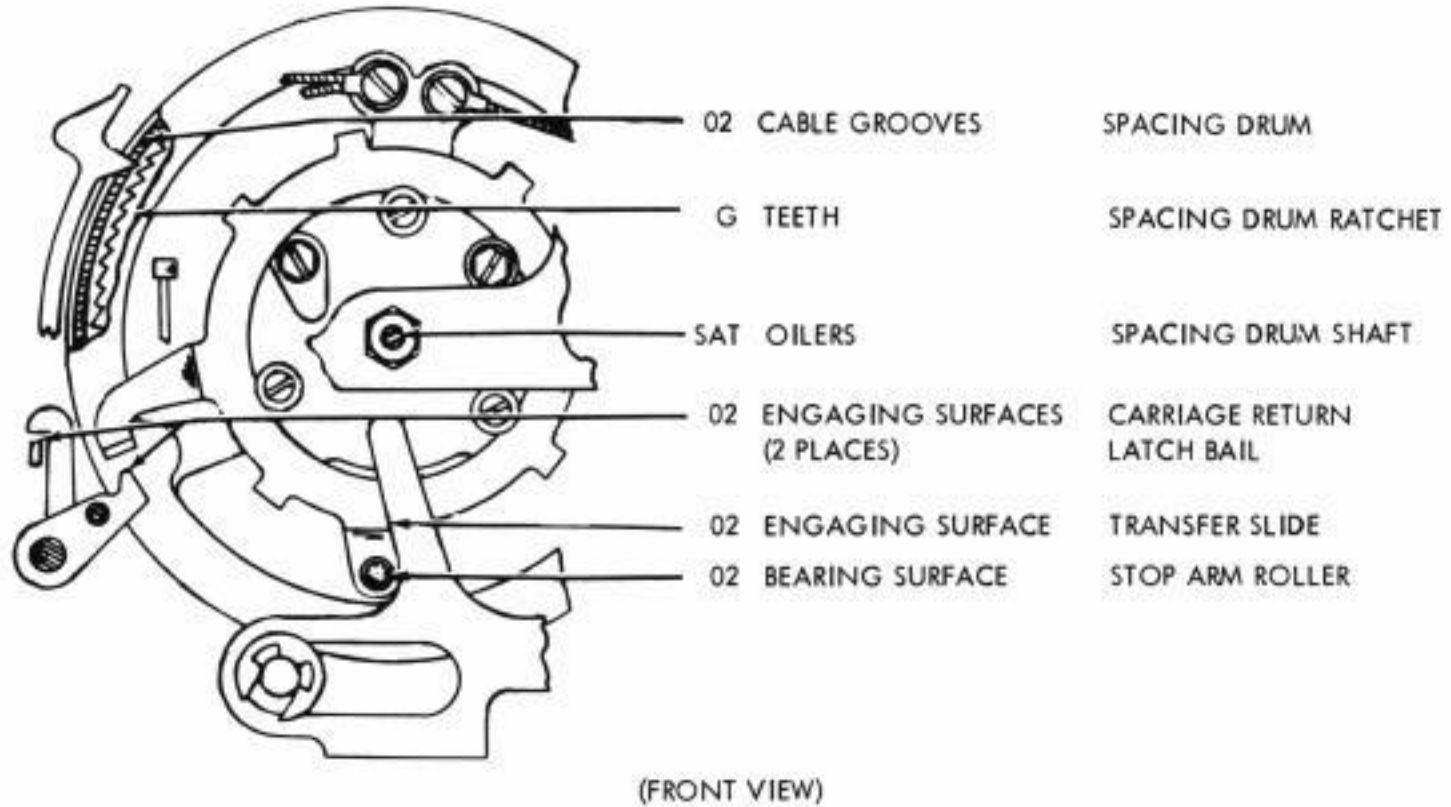

2.31 Spacing Drum Drive Mechanism - Earlier Design

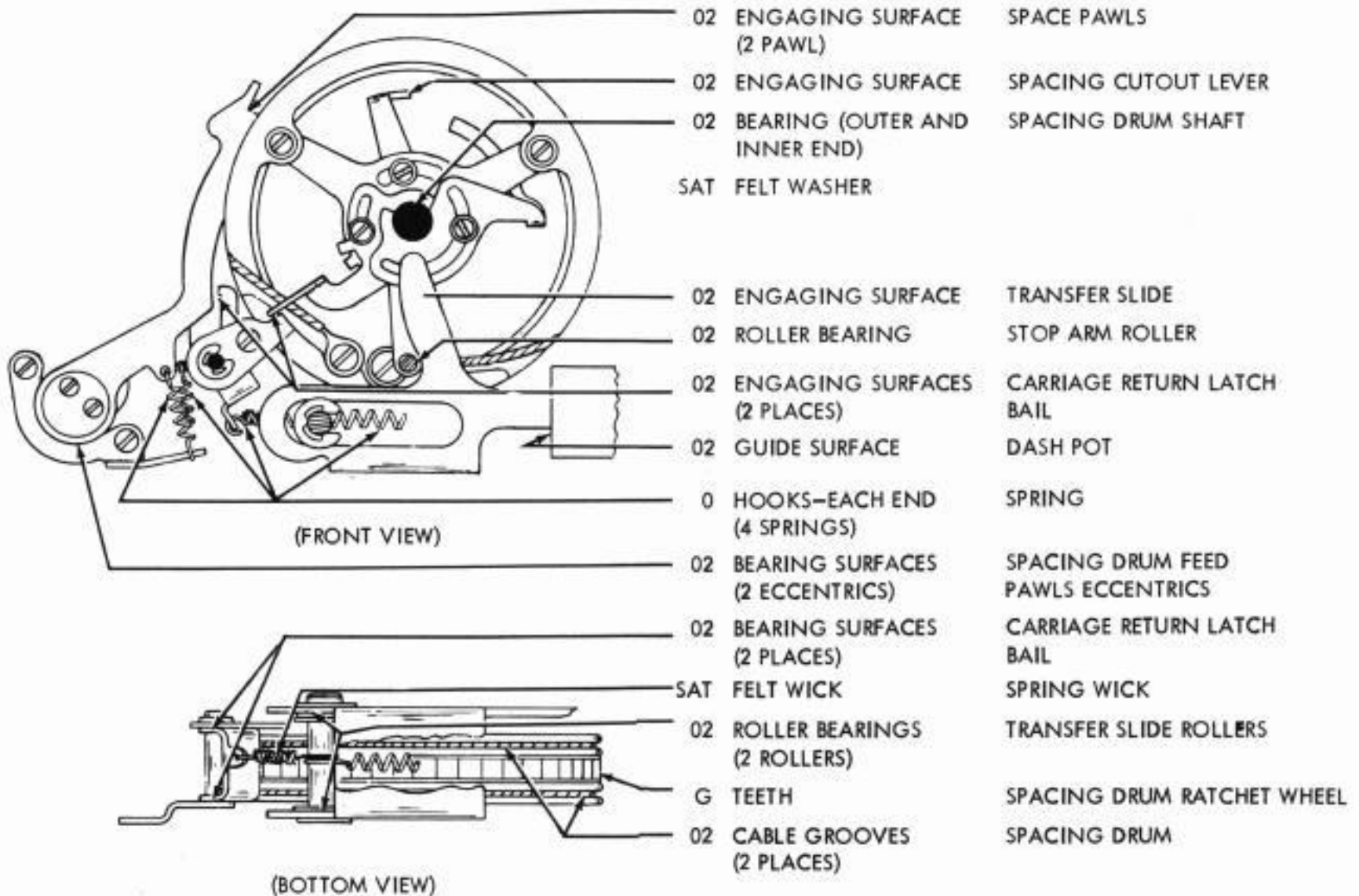

(SEE PARAGRAPH 6.08)

2.32 Carriage Return Mechanism

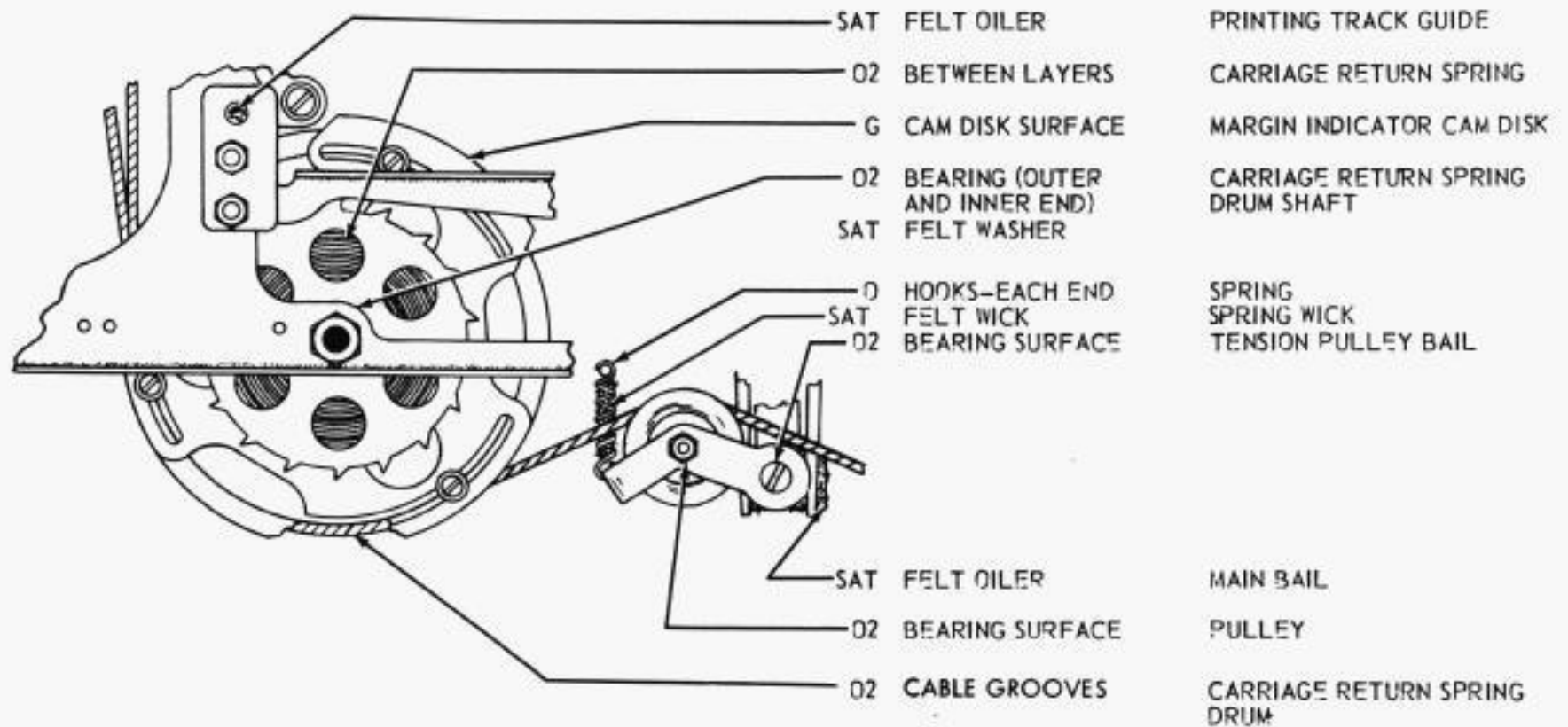

2.33 Spacing Drum Feed Mechanism

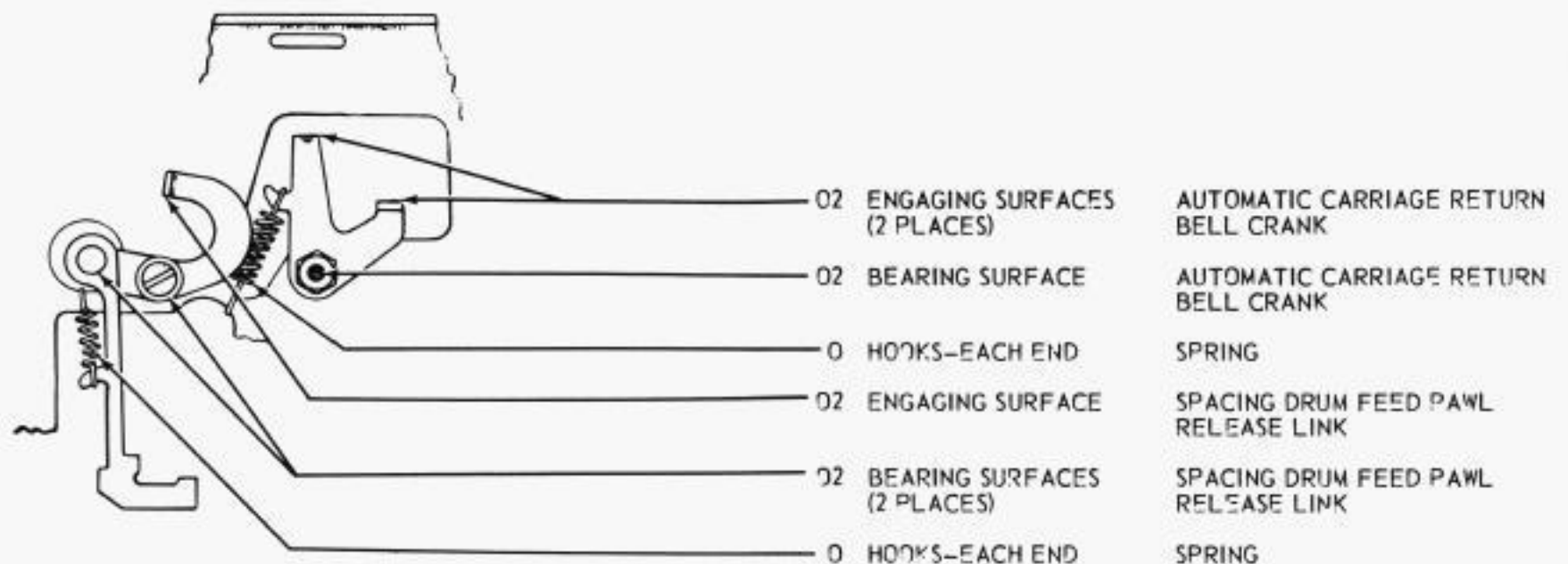

2.34 Track Guide Mechanism

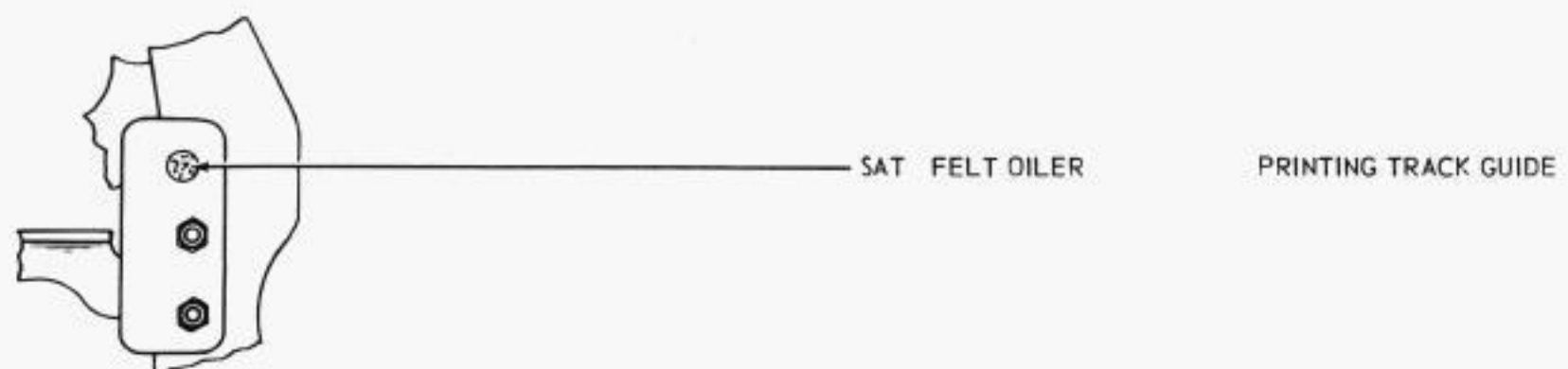

2.35 Typing Unit - Front View

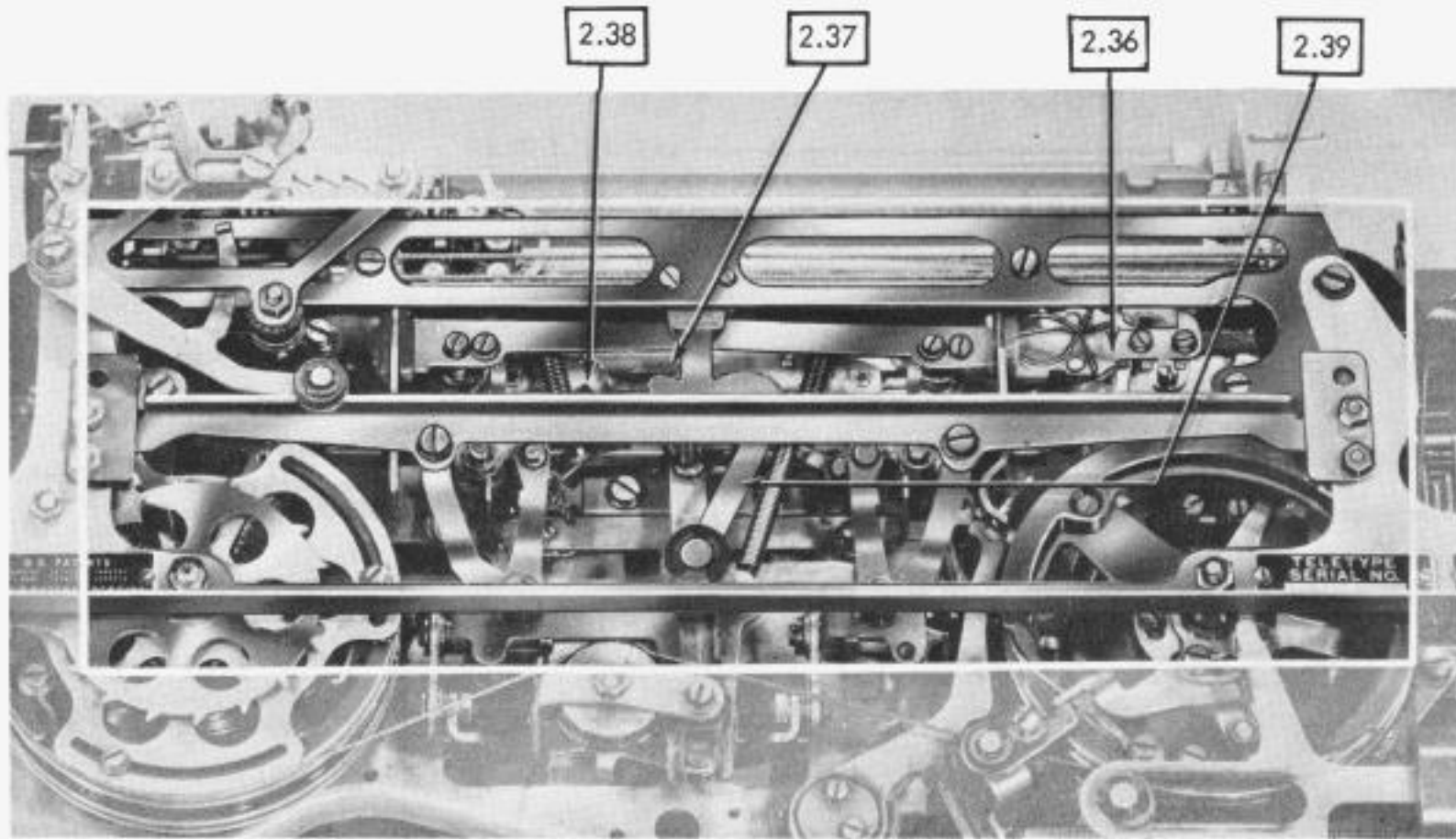

(FRONT VIEW)

2.36 Horizontal Positioning Mechanism

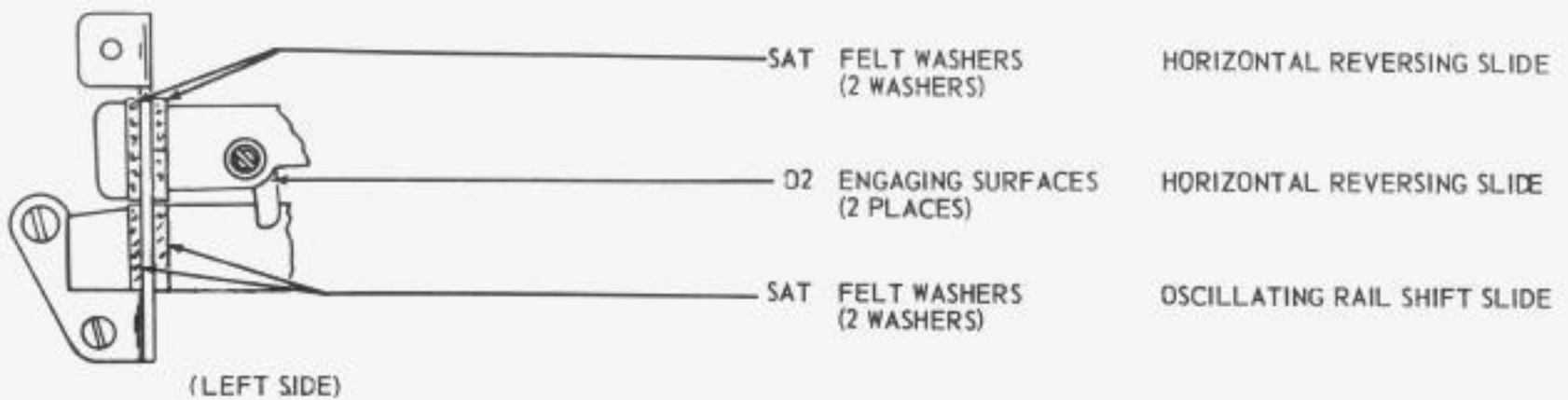
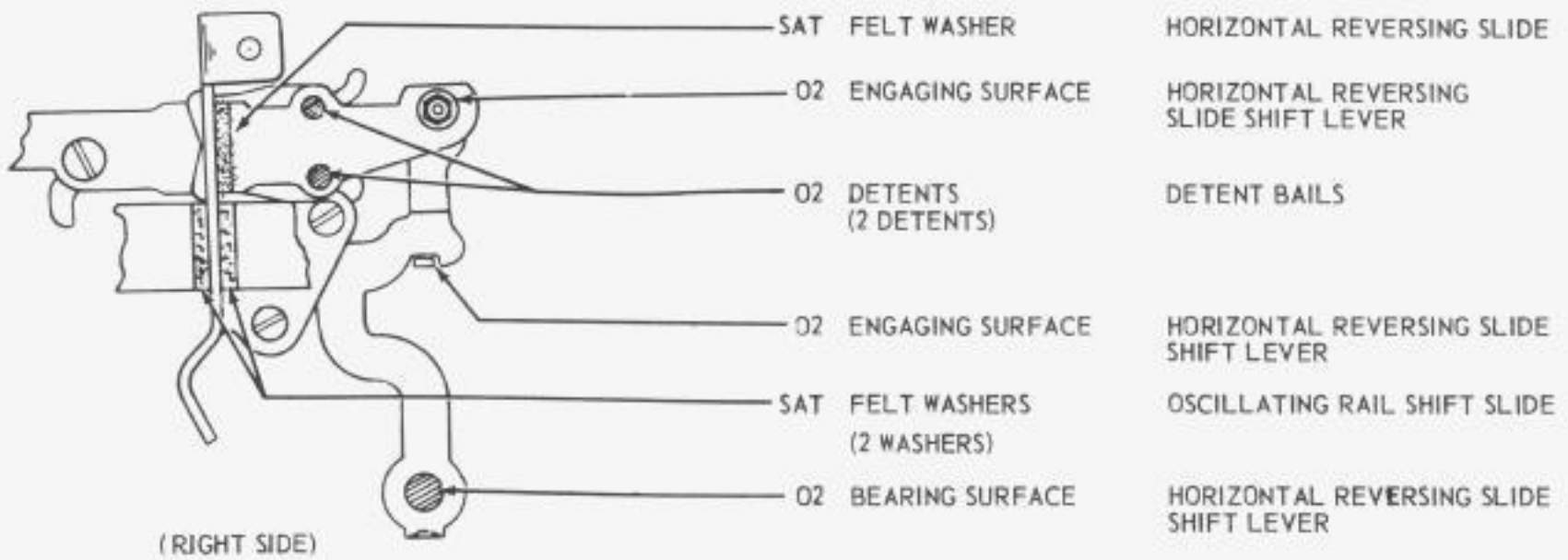

2.37 Horizontal Positioning Mechanism (Cont'd)

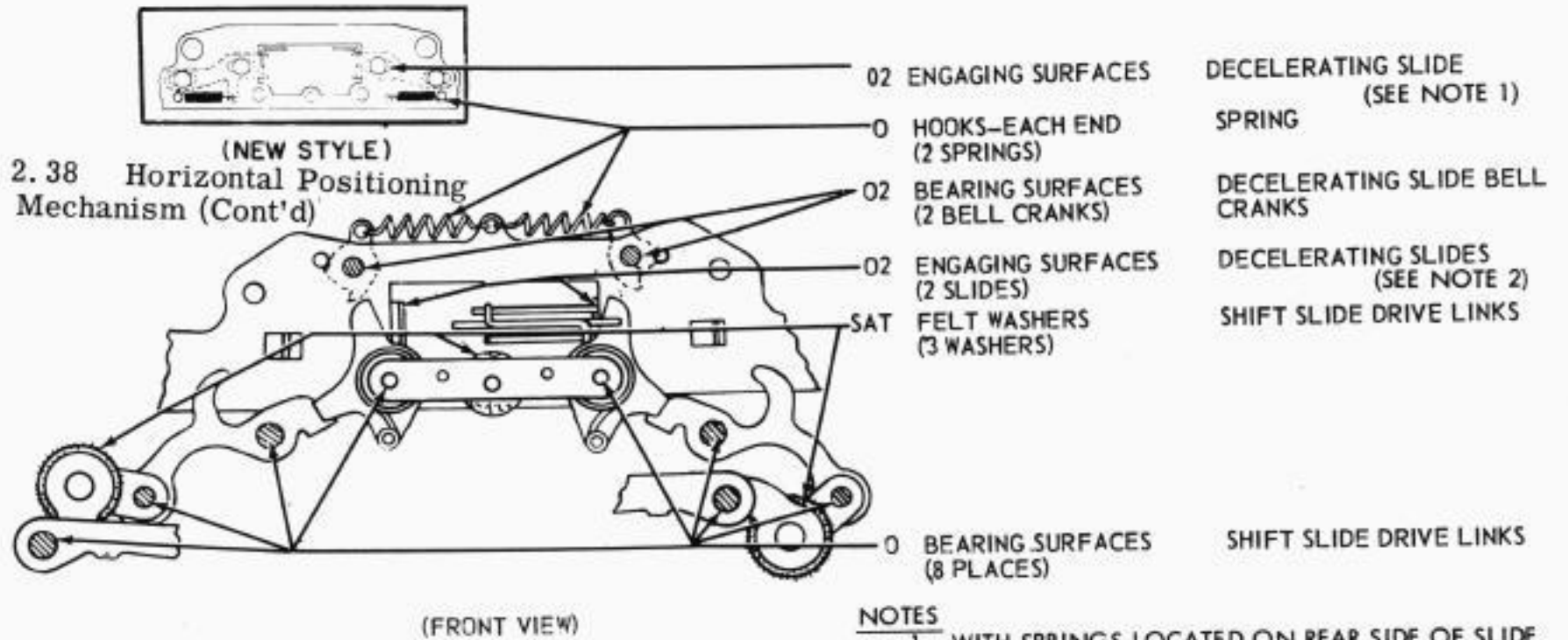
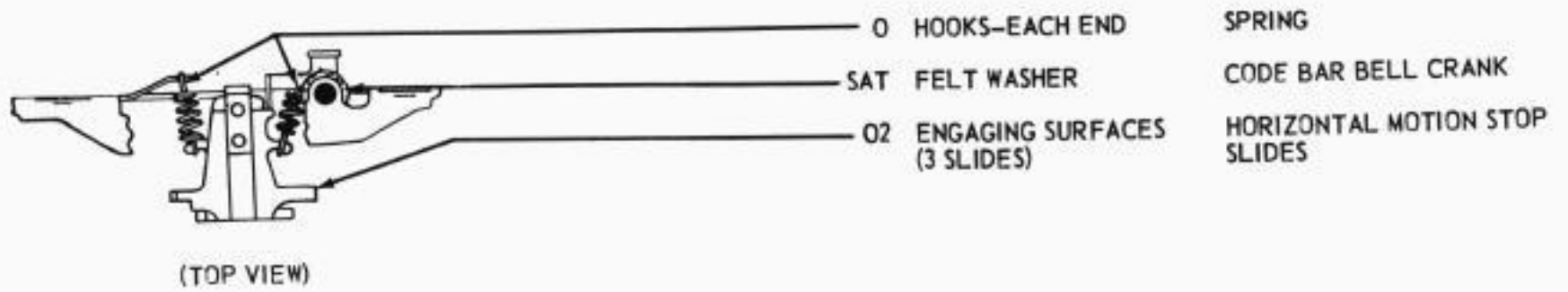

2.38 Horizontal Positioning Mechanism (Cont'd)

- NOTES
1. WITH SPRINGS LOCATED ON REAR SIDE OF SLIDE
 2. WITH SPRINGS LOCATED ABOVE THE SLIDE

2.39 Horizontal Positioning Mechanism (Cont'd)

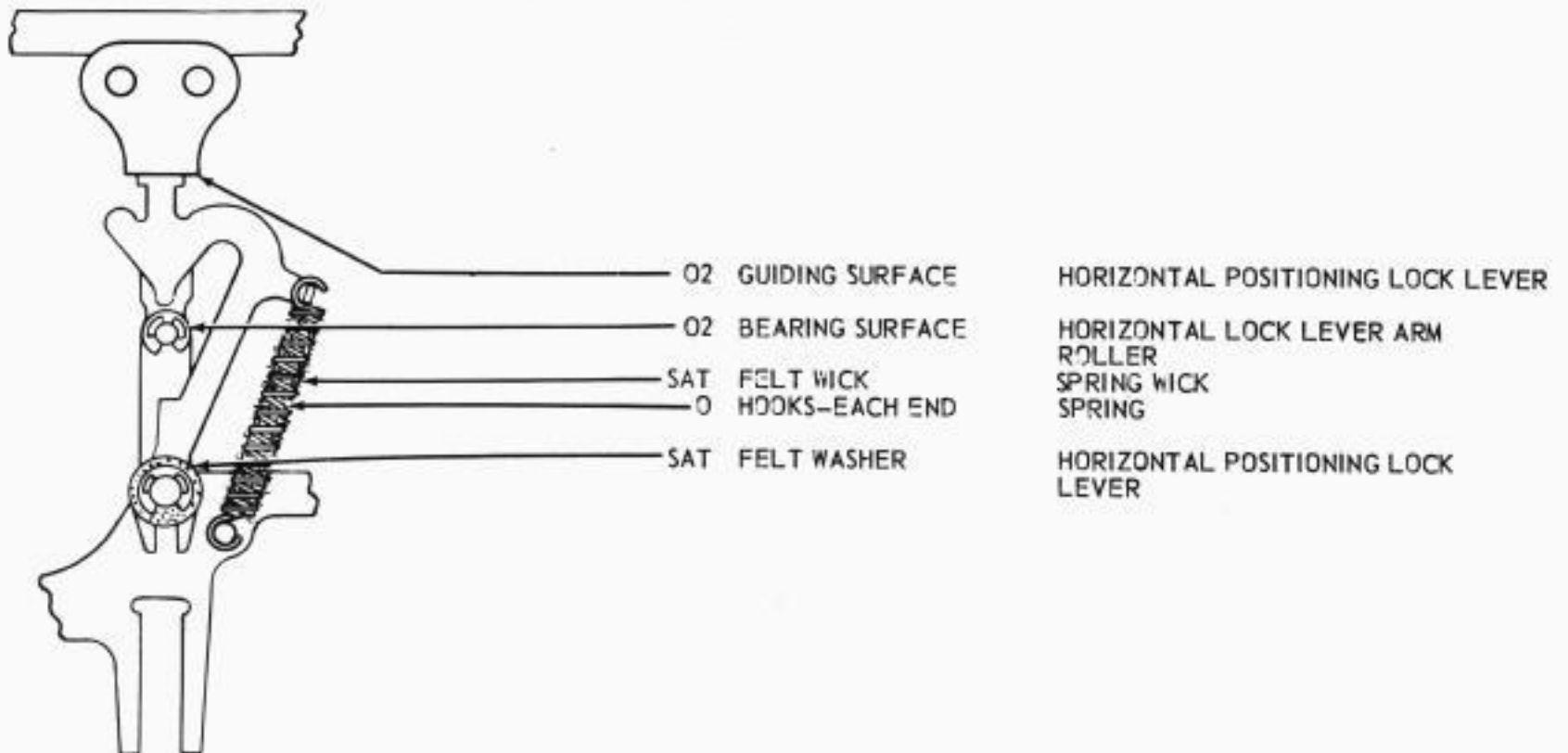

2.40 Typing Unit - Front View

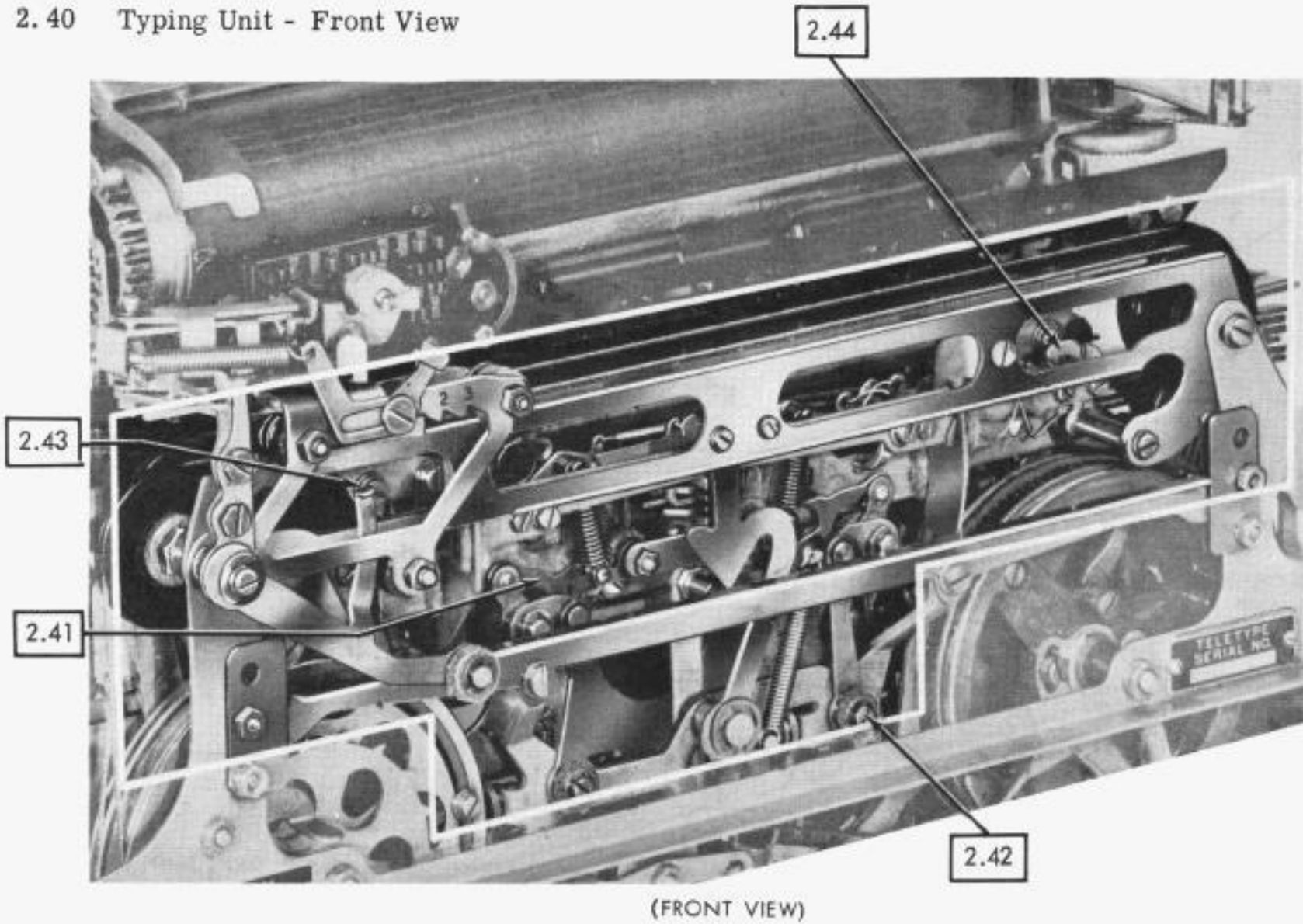

2.41 Letters - Figures Shift Mechanism

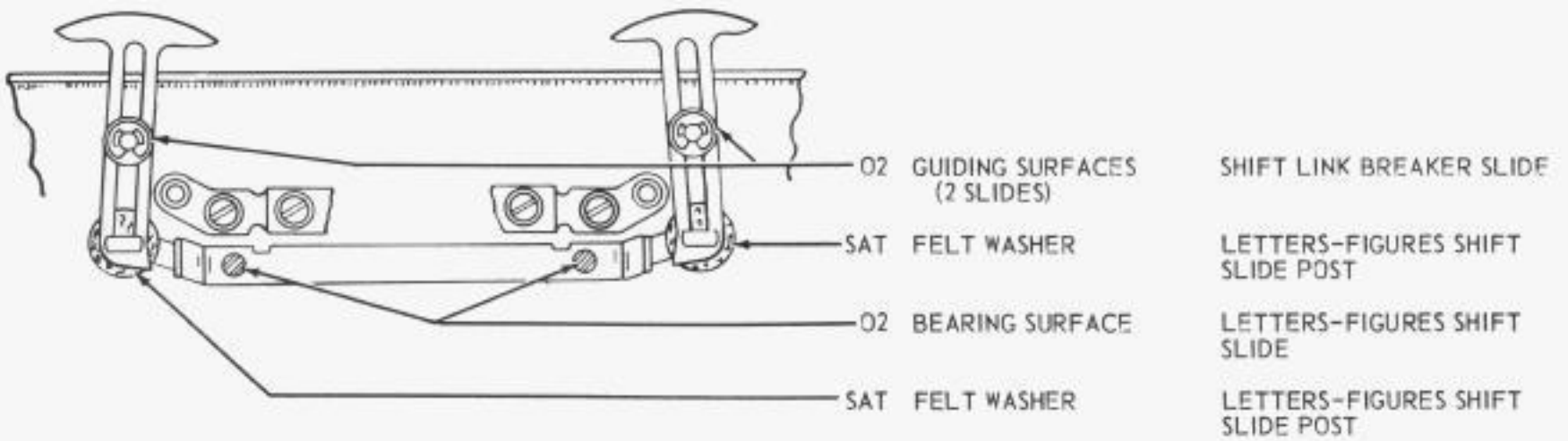

2.42 Letters - Figures Shift Mechanism (Cont'd)

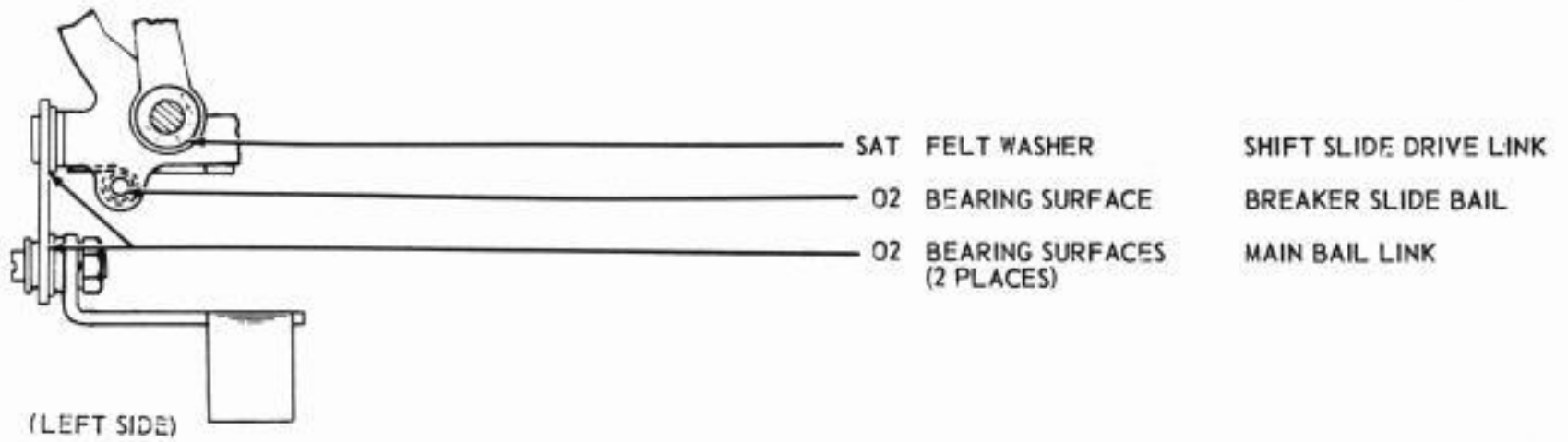
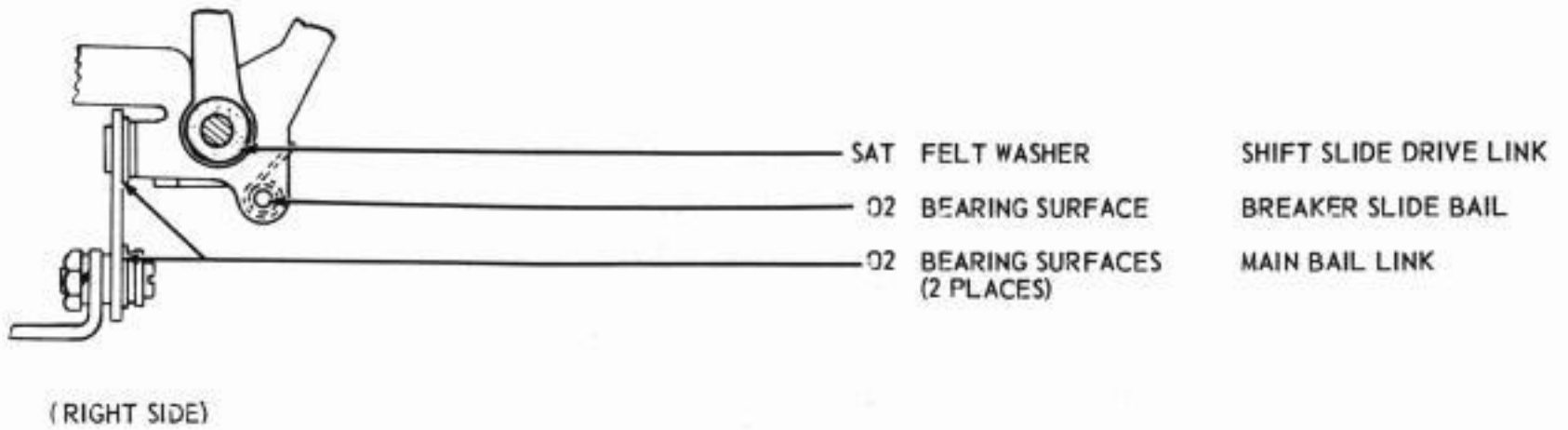

2.43 Oscillating Mechanism

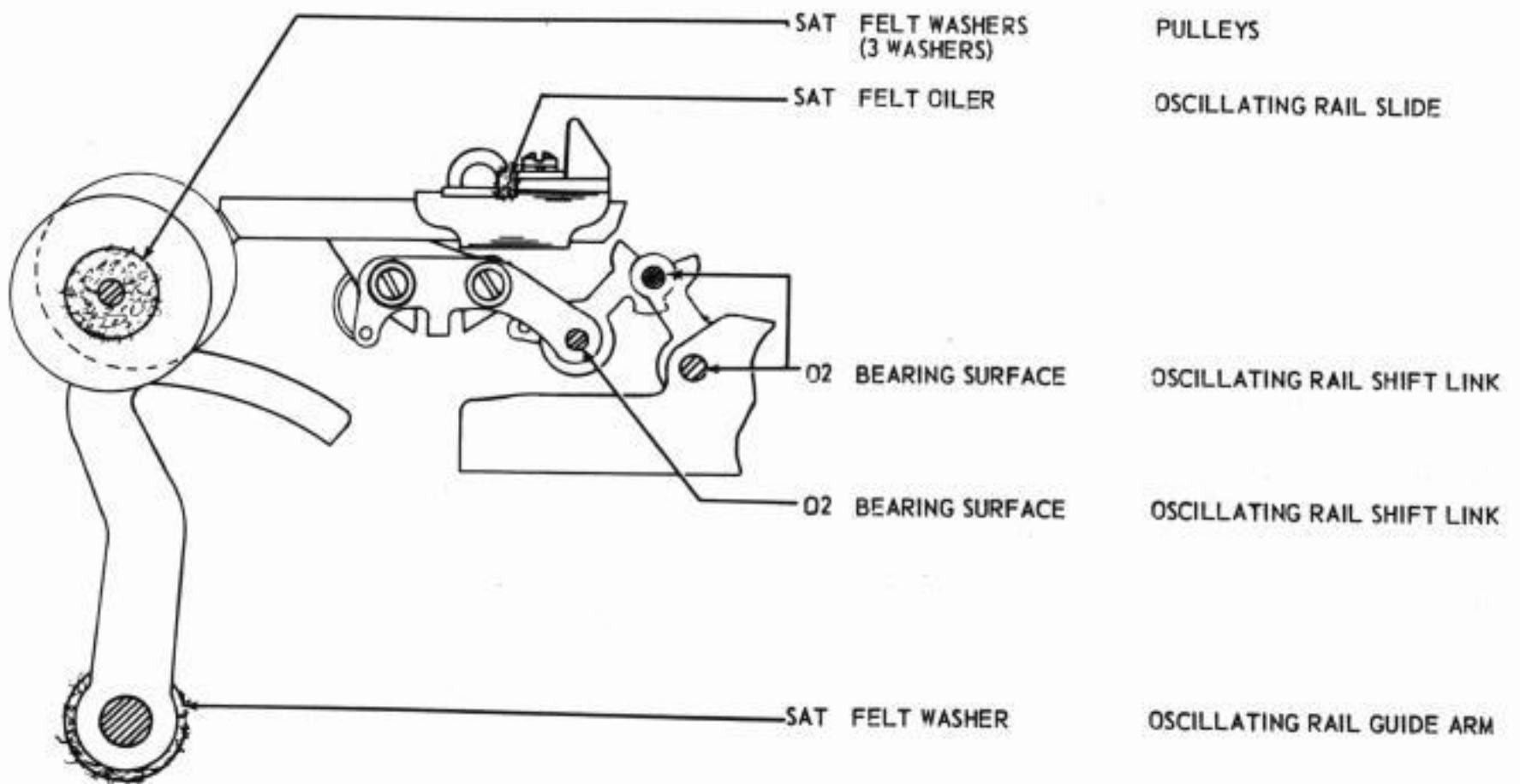

2.44 Oscillating Mechanism (Cont'd)

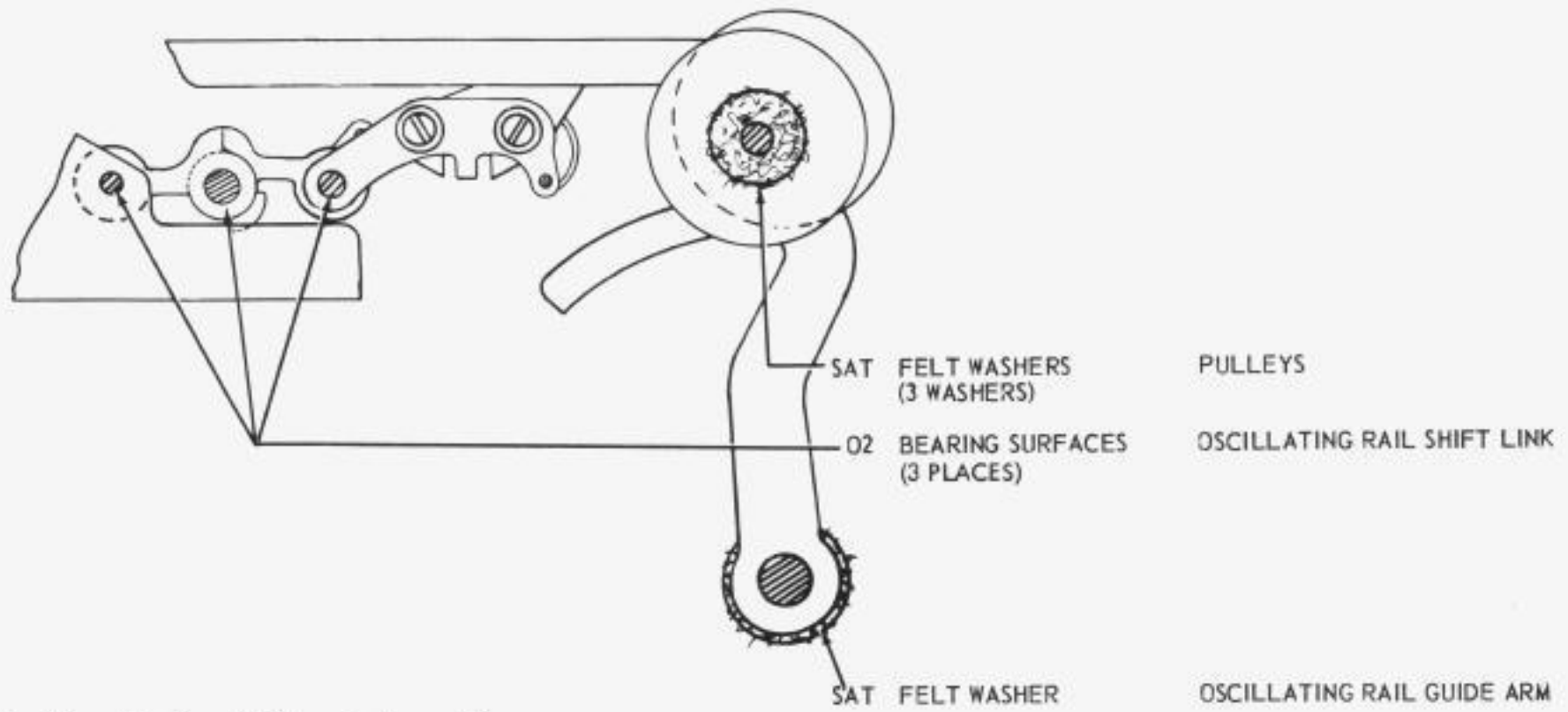

2.45 Typing Unit - Bottom View

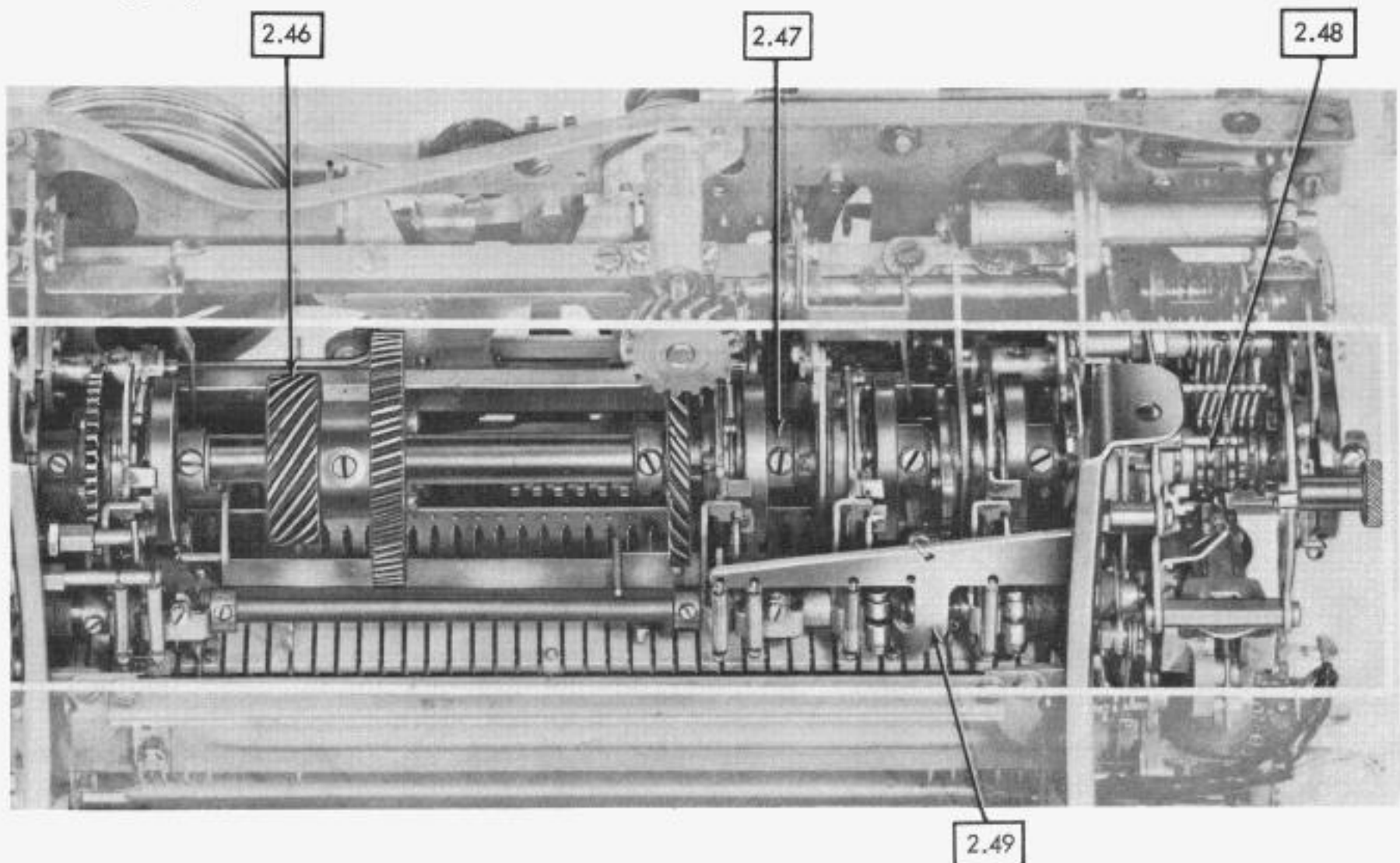

2.46 Main Shaft - Clutches, Gears, Etc.

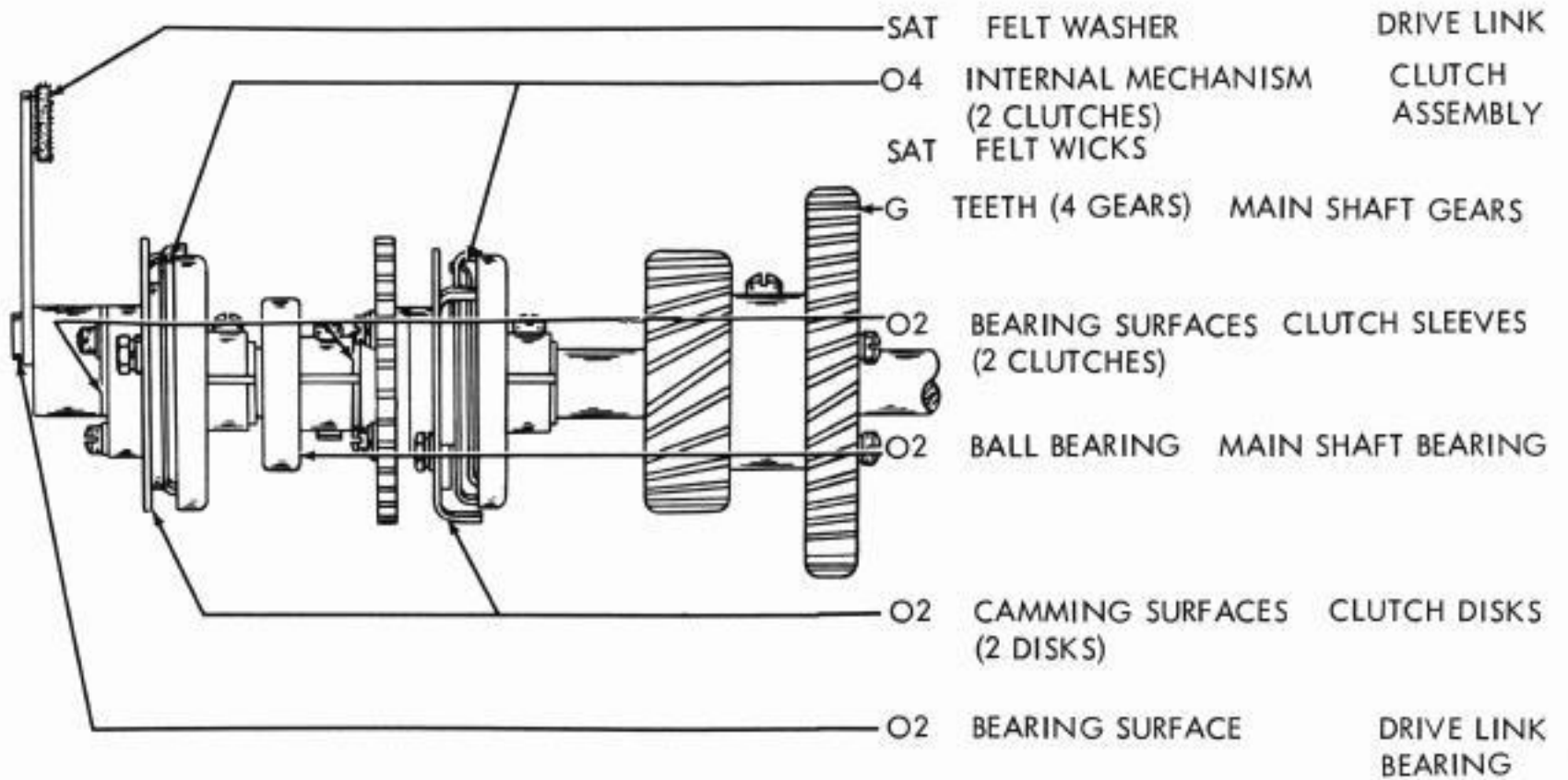

2.47 Main Shaft Mechanism

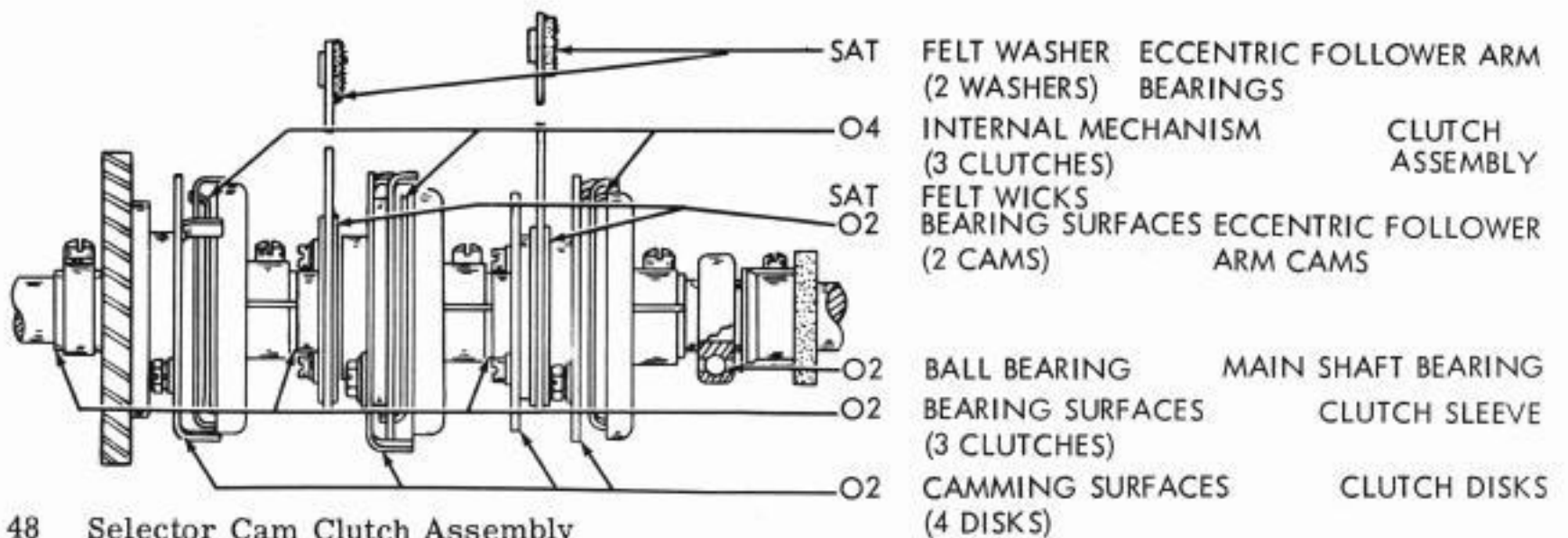

2.48 Selector Cam Clutch Assembly

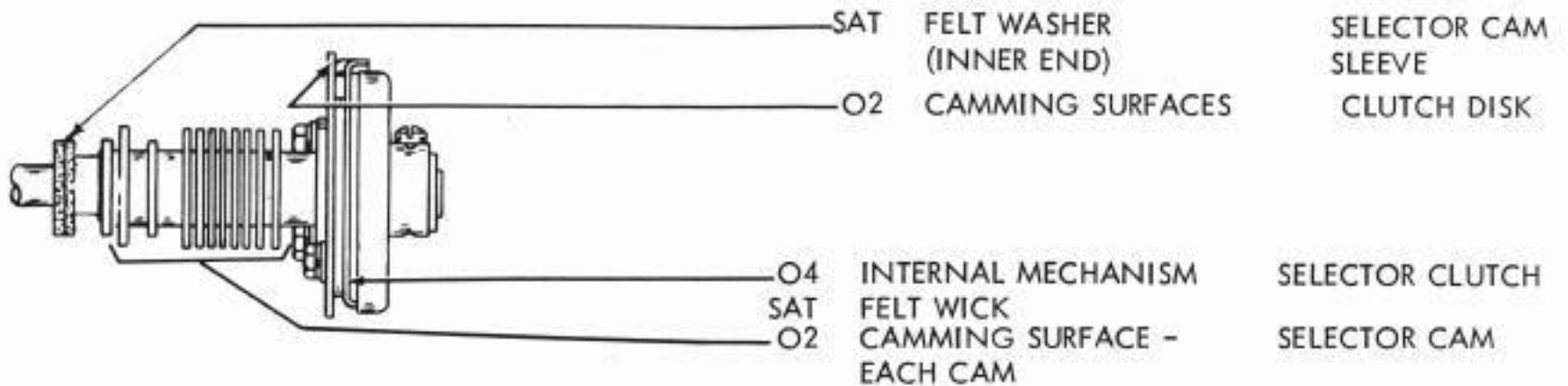

2.49 Main Shaft - Clutches, Gears, Etc. (Cont'd)

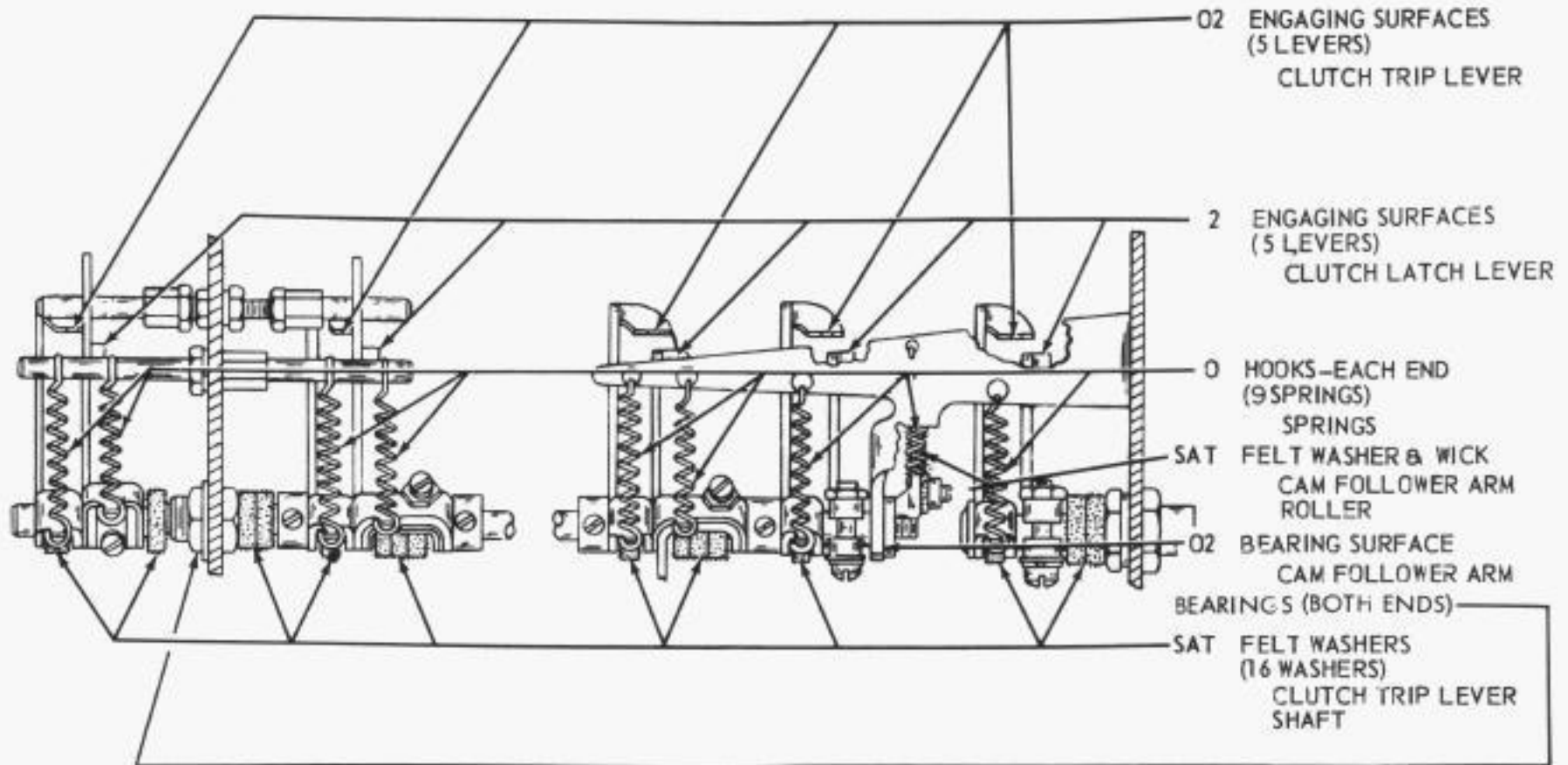

2.50 Typing Unit - Bottom View

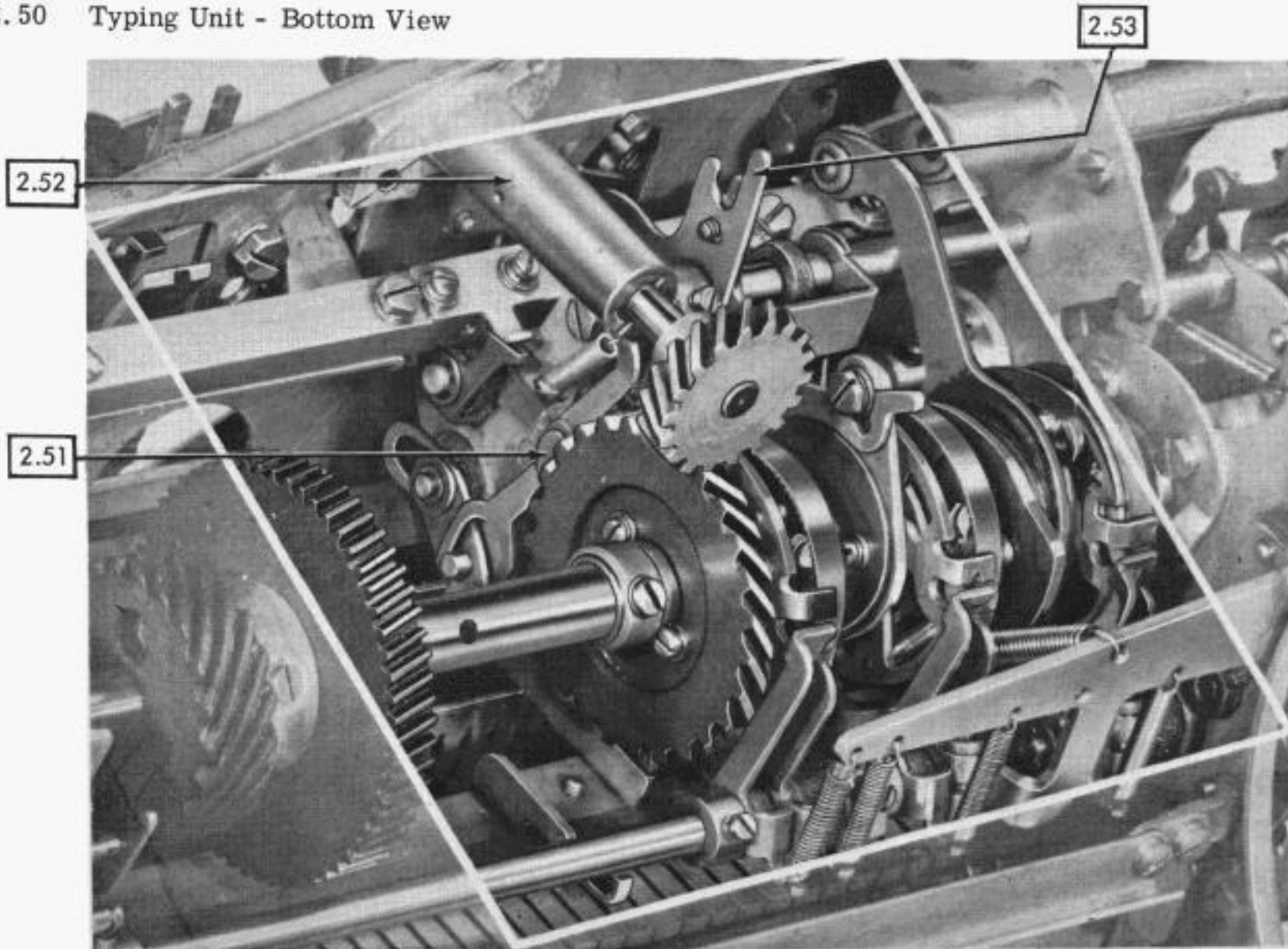

2.51 Spacing Mechanism

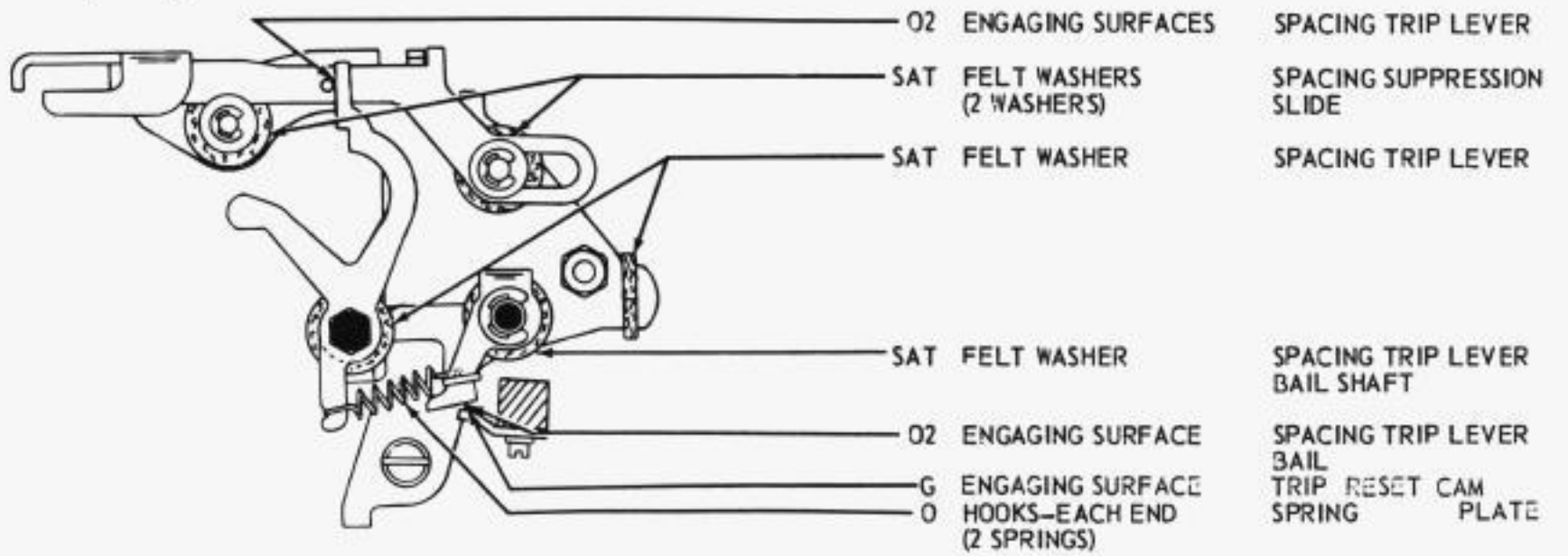

2.52 Spacing Mechanism (Cont'd)

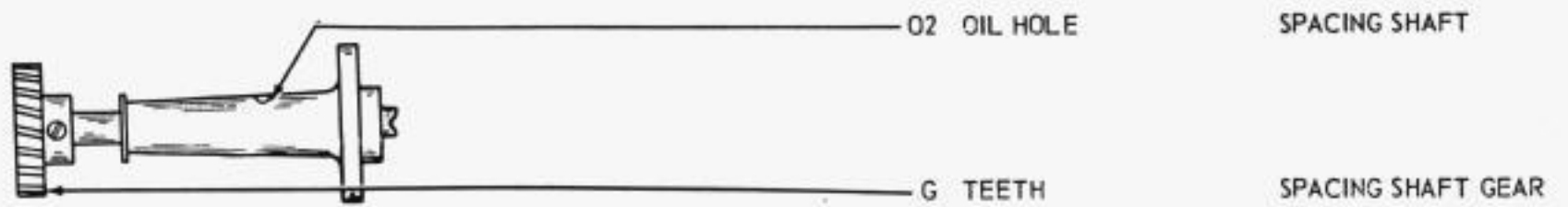

2.53 Spacing Mechanism (Cont'd)

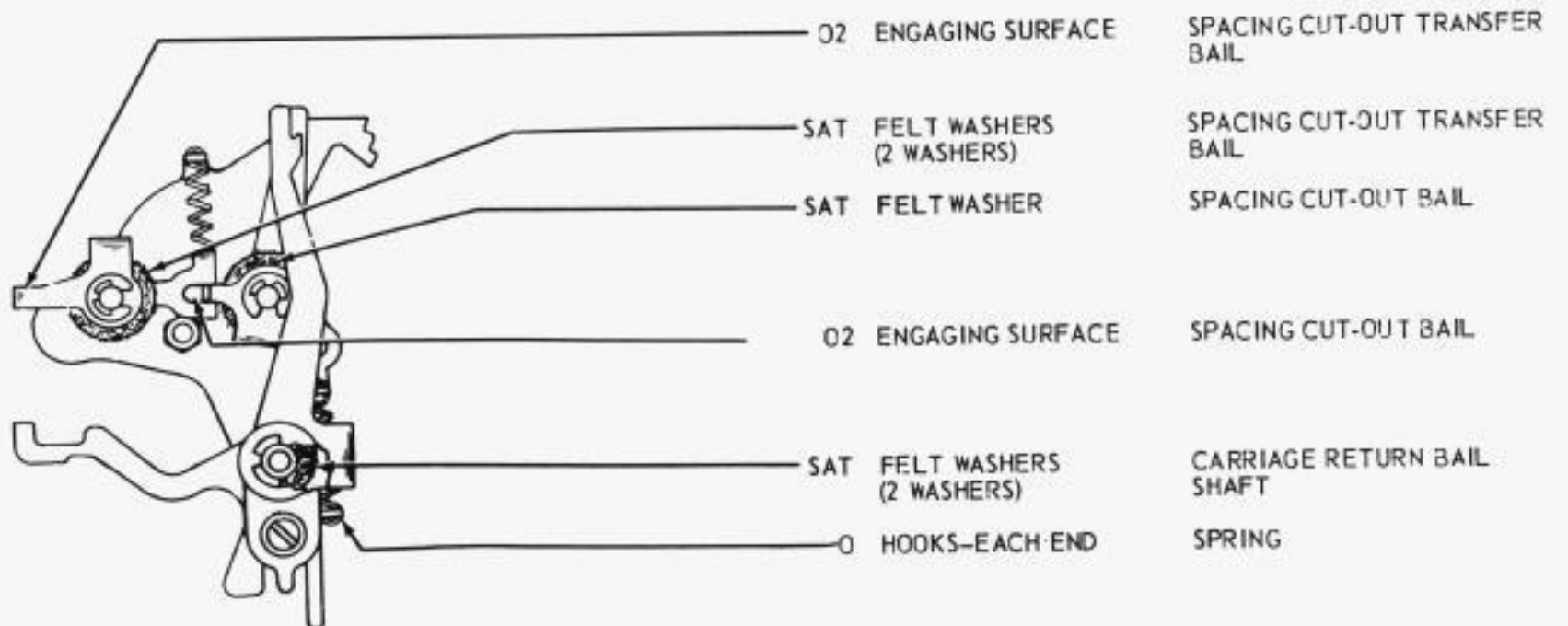

2.54 Typing Unit - Rear Left View

2.55 Paper Spindle Latch Mechanism

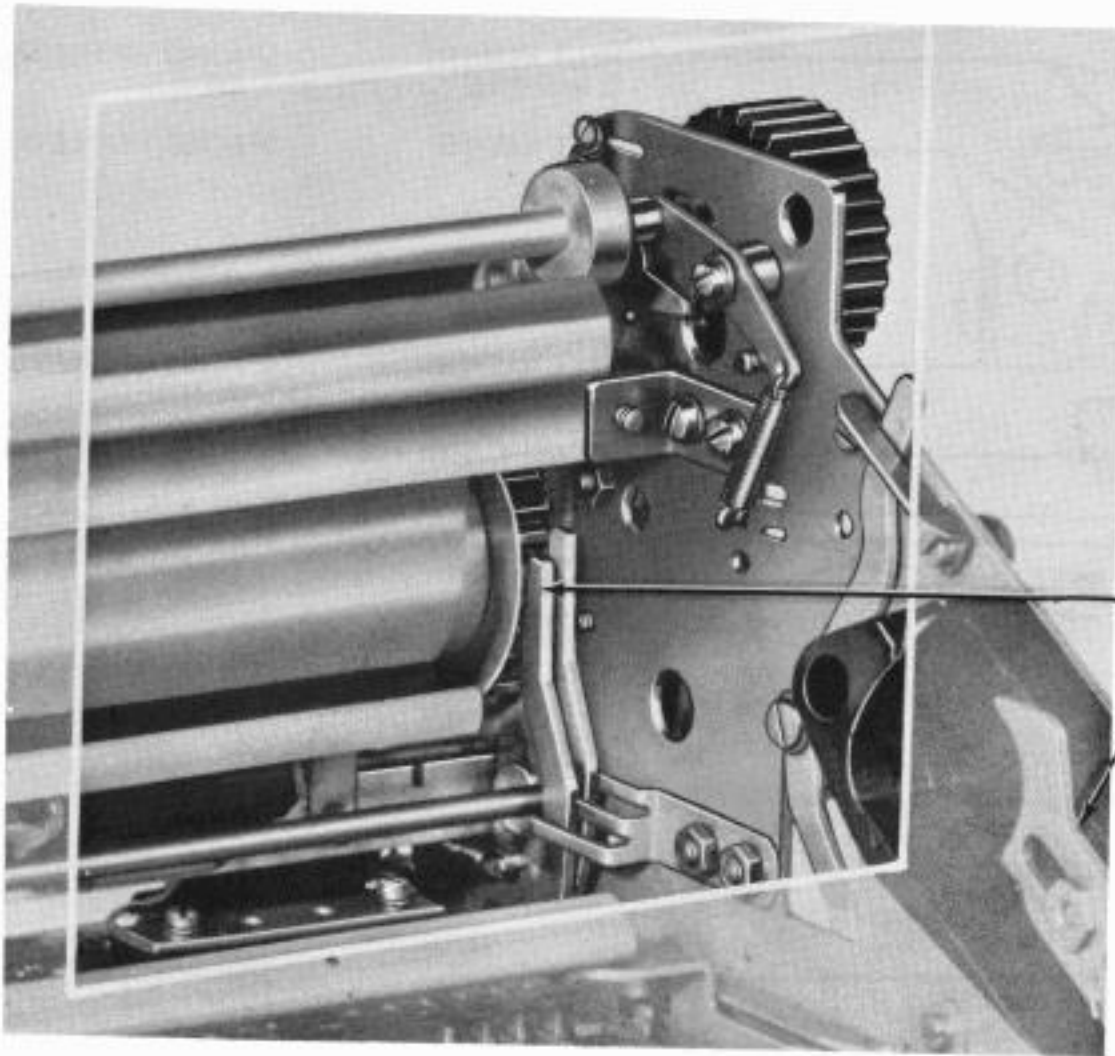

2.56

2.55

O LATCH (2 PLACES) PAPER SPINDLE LATCH

2.56 Line Feed Mechanism - Friction Feed

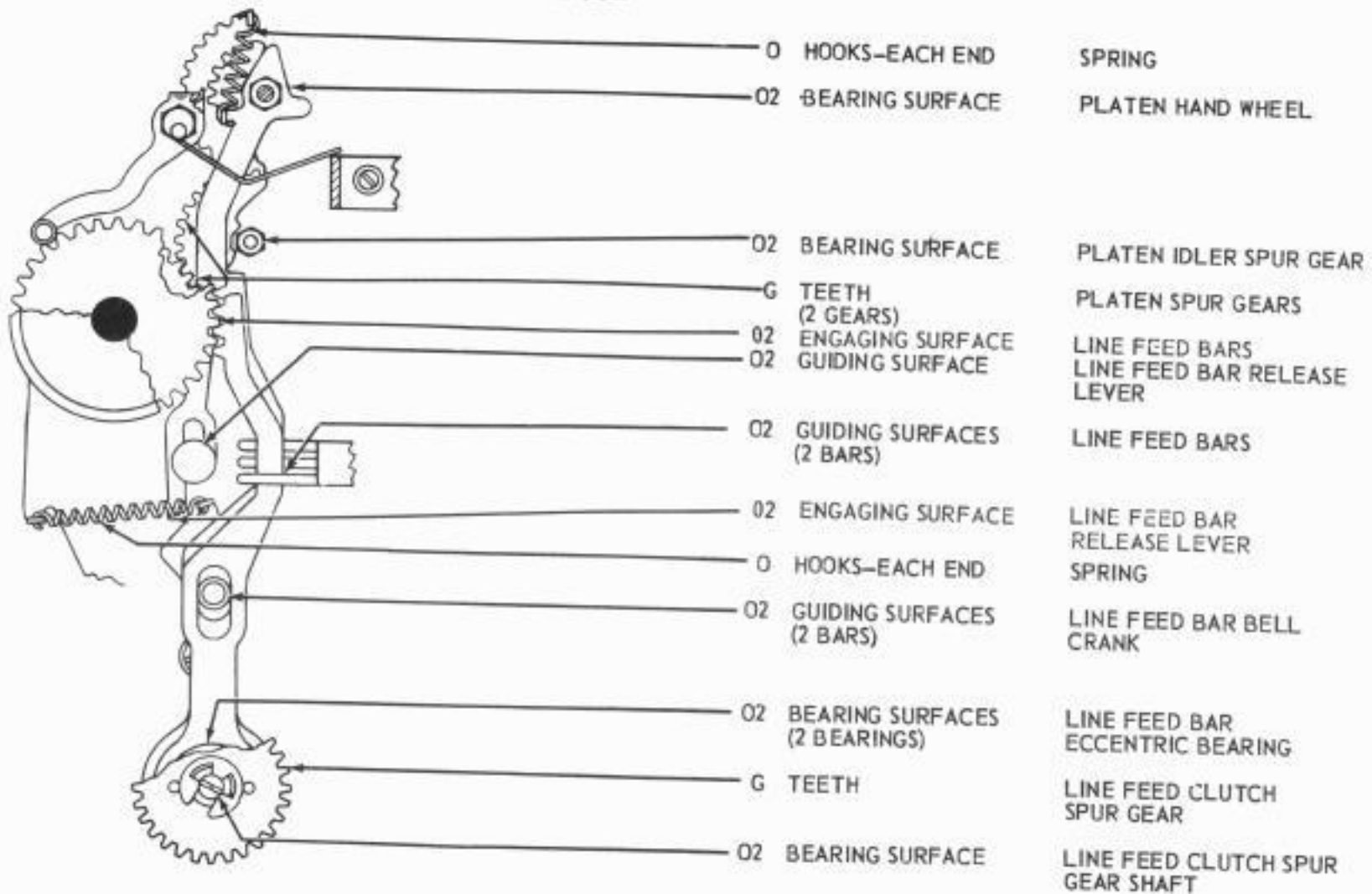

2.57 Typing Unit - Rear Top View

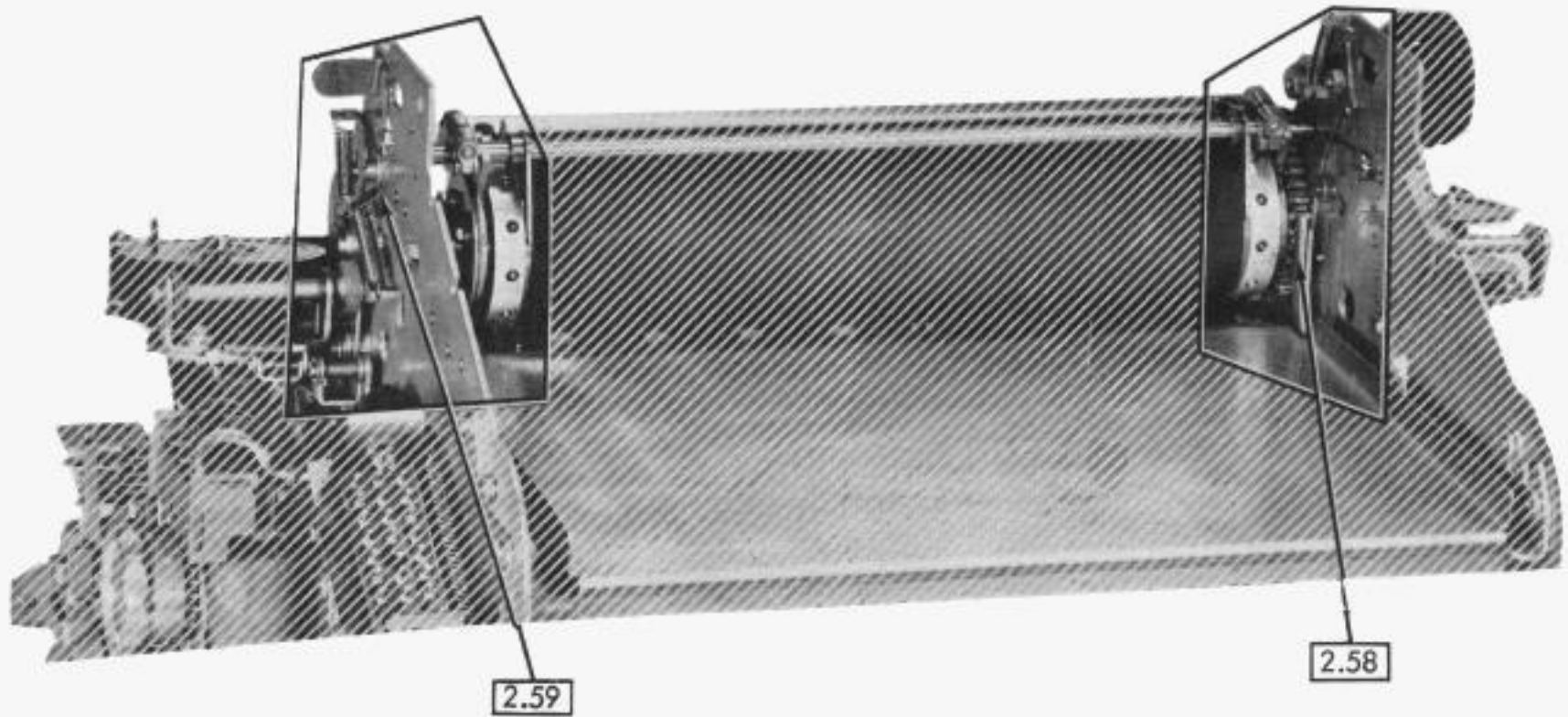

2.58 Line Feed Mechanism - Sprocket Feed

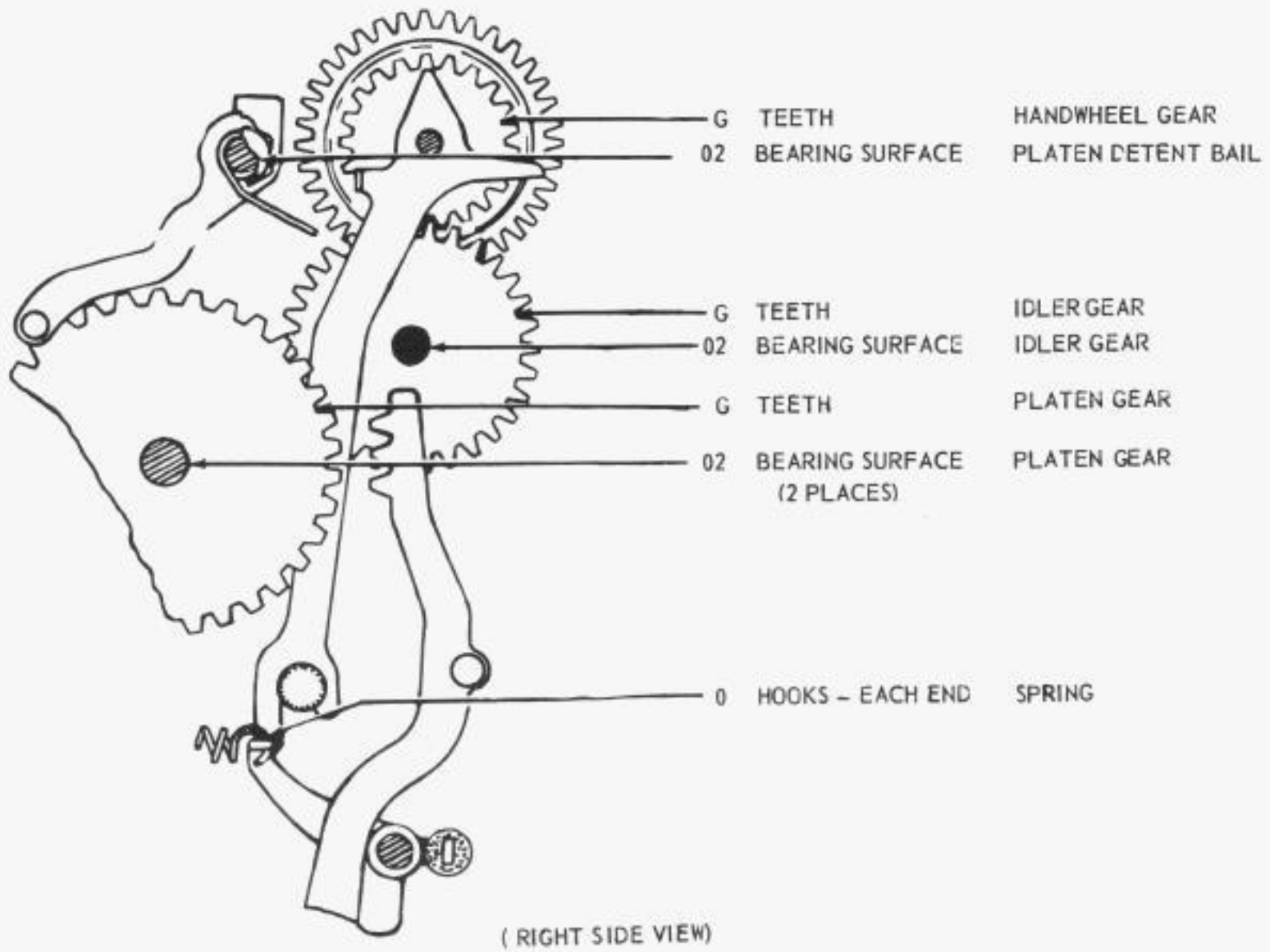

2.59 Paper Guide Mechanism - Sprocket Feed

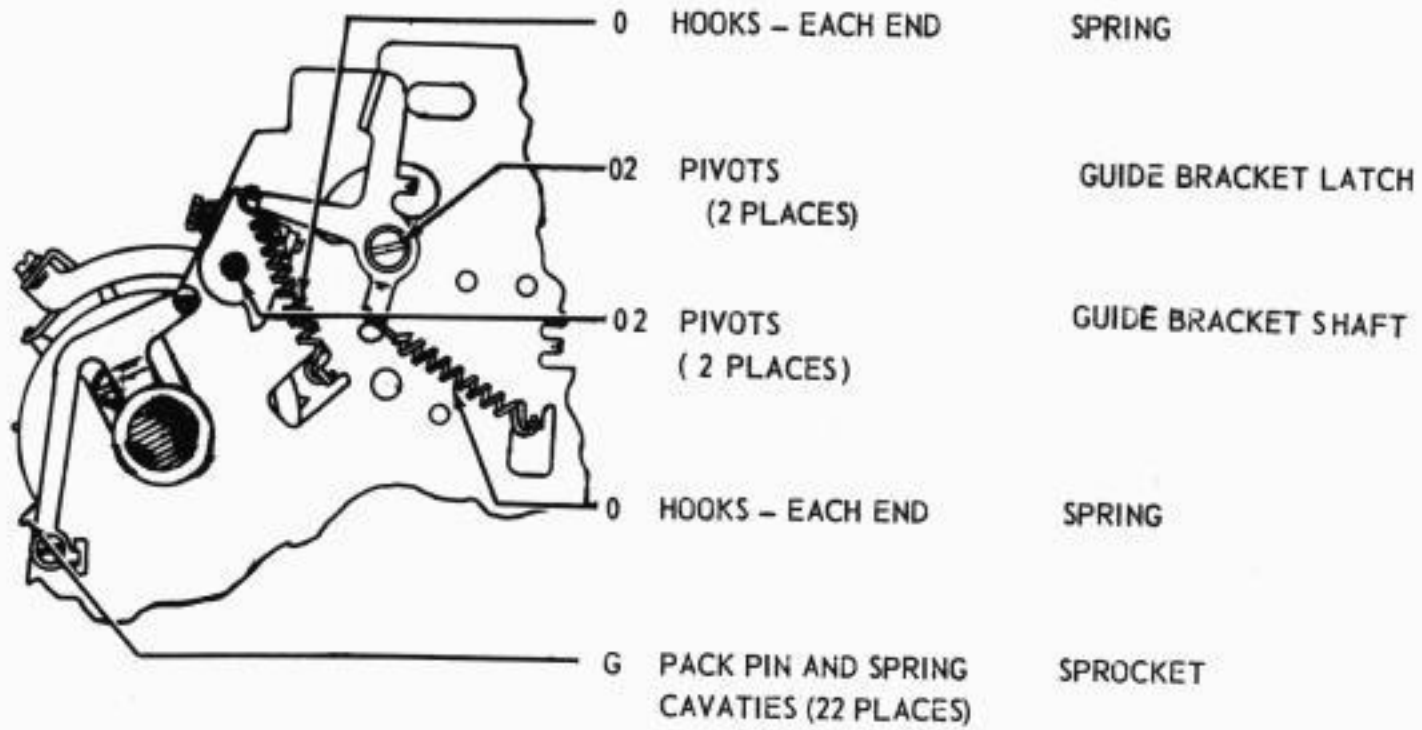

(RIGHT SIDE VIEW)

NOTE: BEFORE ATTEMPTING TO DISASSEMBLY
THE 153700 PLATEN HUB, SEE DISASSEMBLY
AND REASSEMBLY INSTRUCTIONS,
SECTION 573-115-702.

3. VARIABLE FEATURES

HORIZONTAL TABULATOR MECHANISM - EARLIER DESIGN

3.01 Typing Unit - Front View

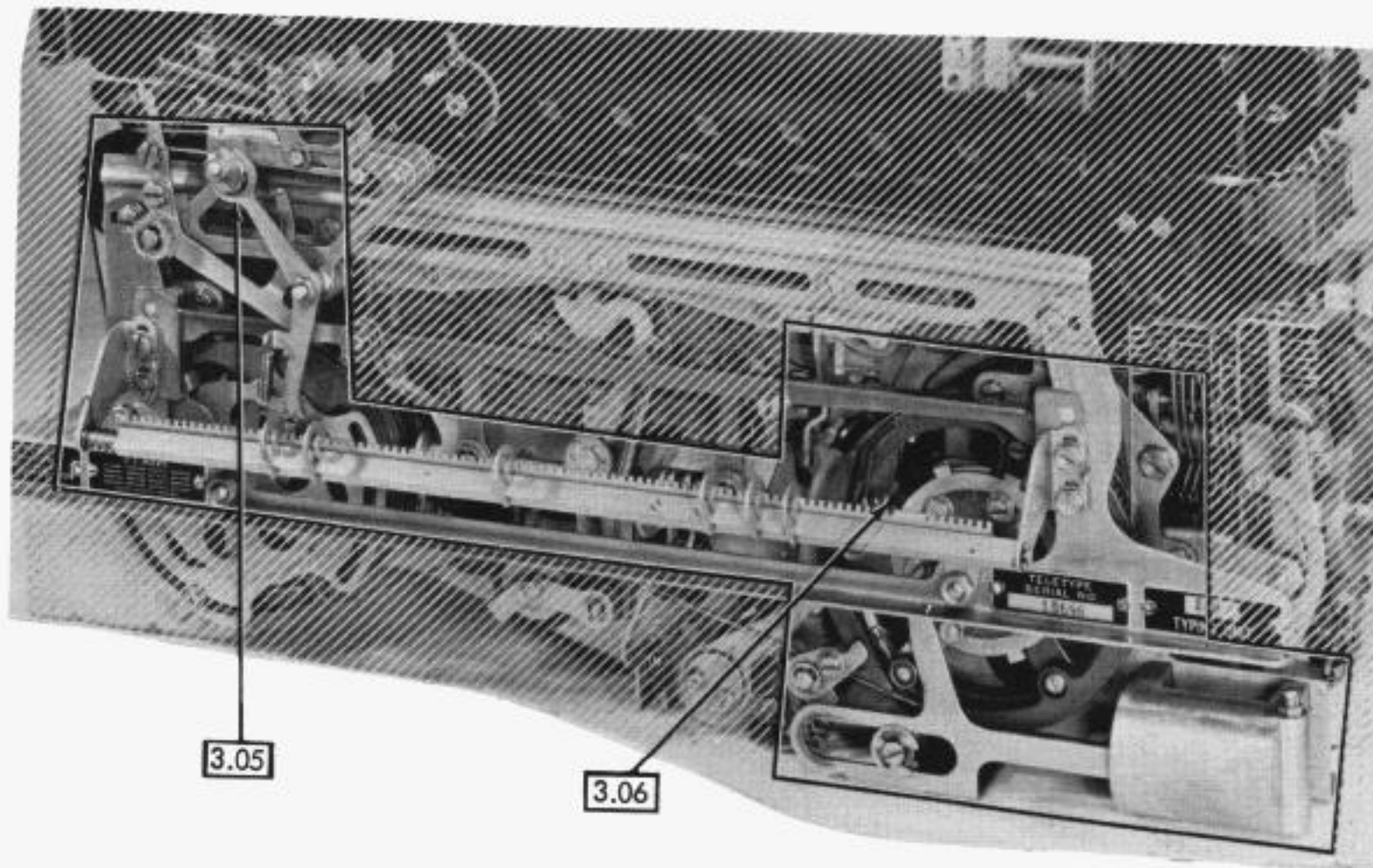

3.02 Tabulator Shaft Mechanism

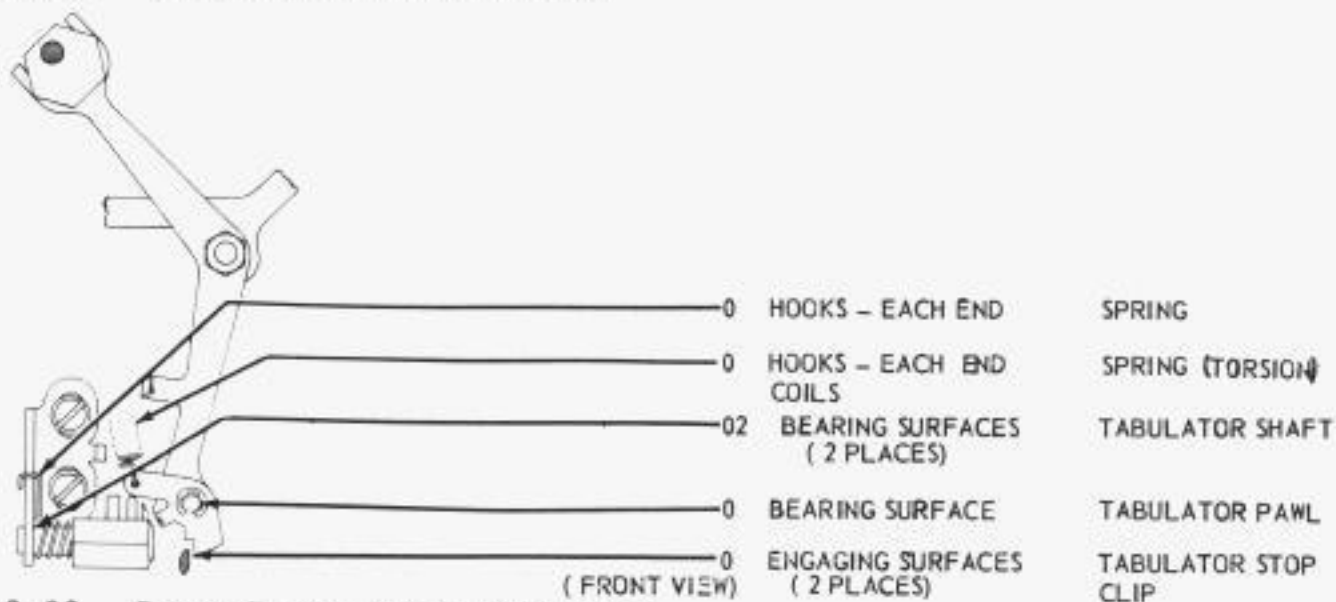

3.03 Space Suppression Mechanism

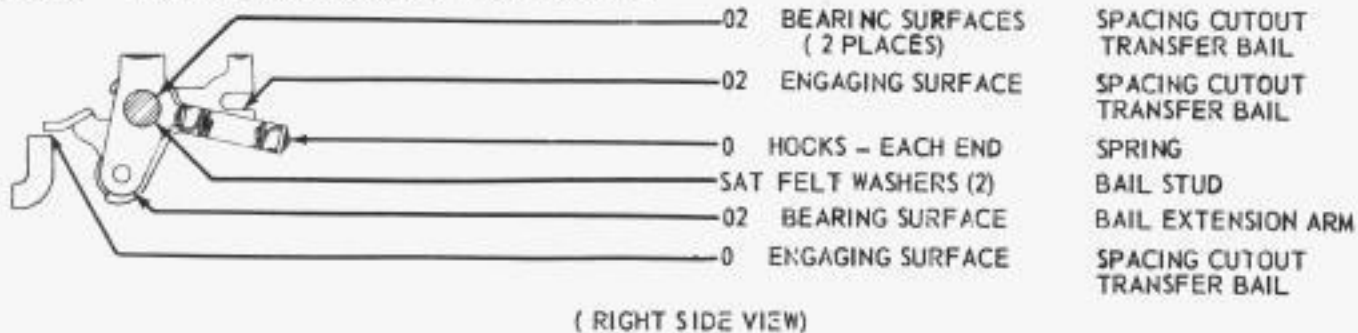

3.04 Typing Unit - Bottom View

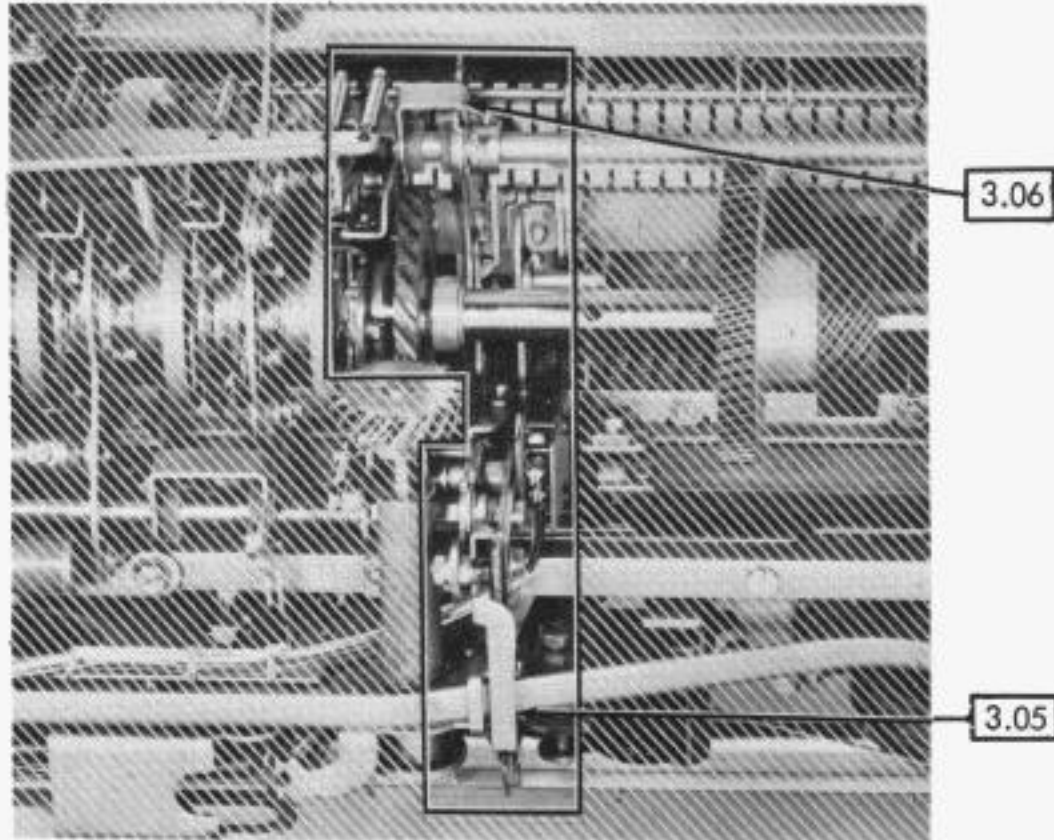

3.05 Operating Lever Mechanism

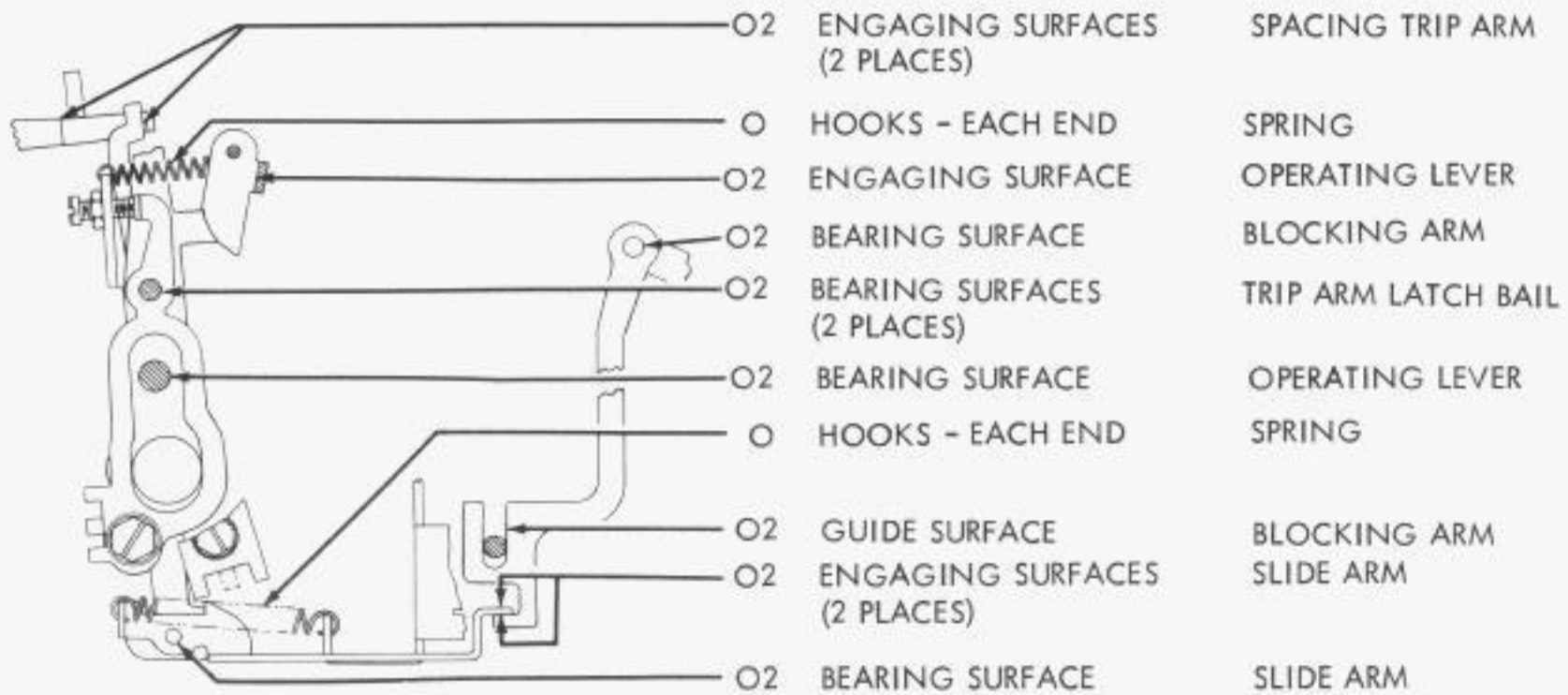

(LEFT SIDE VIEW)

3.06 Spacing Clutch Mechanism

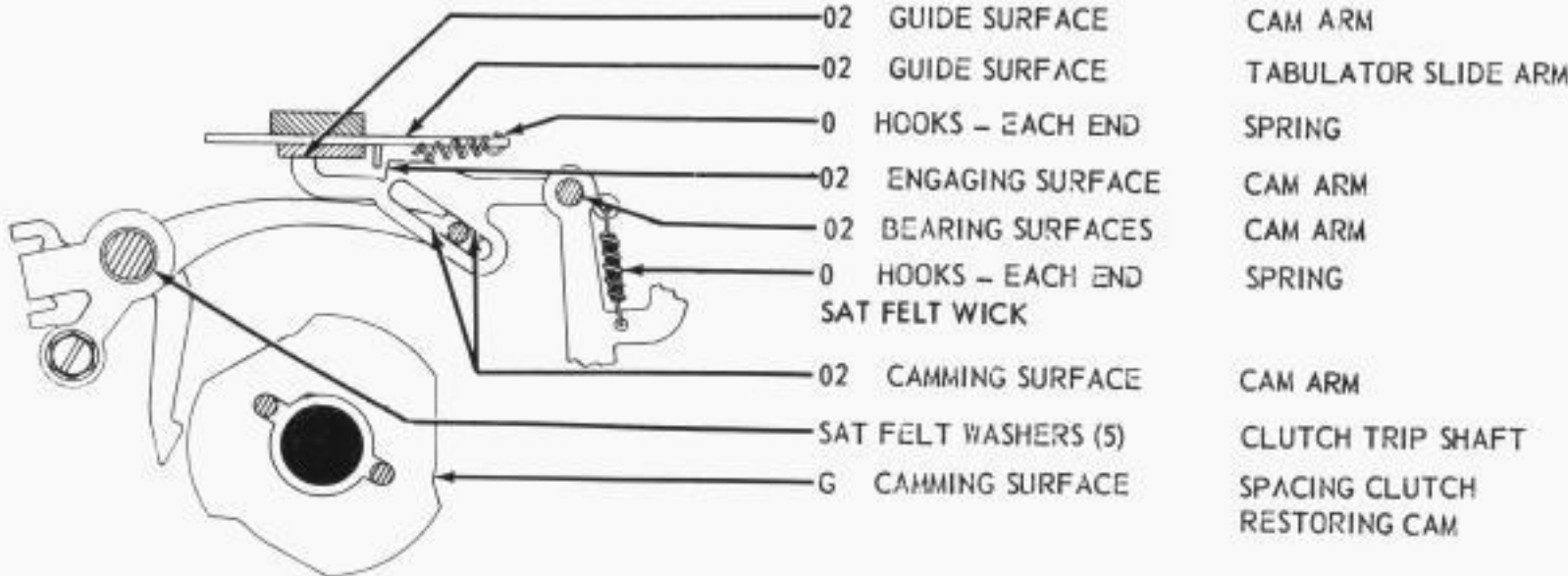

SELECTIVE CALLING MECHANISM

3.07 Typing Unit - Rear View

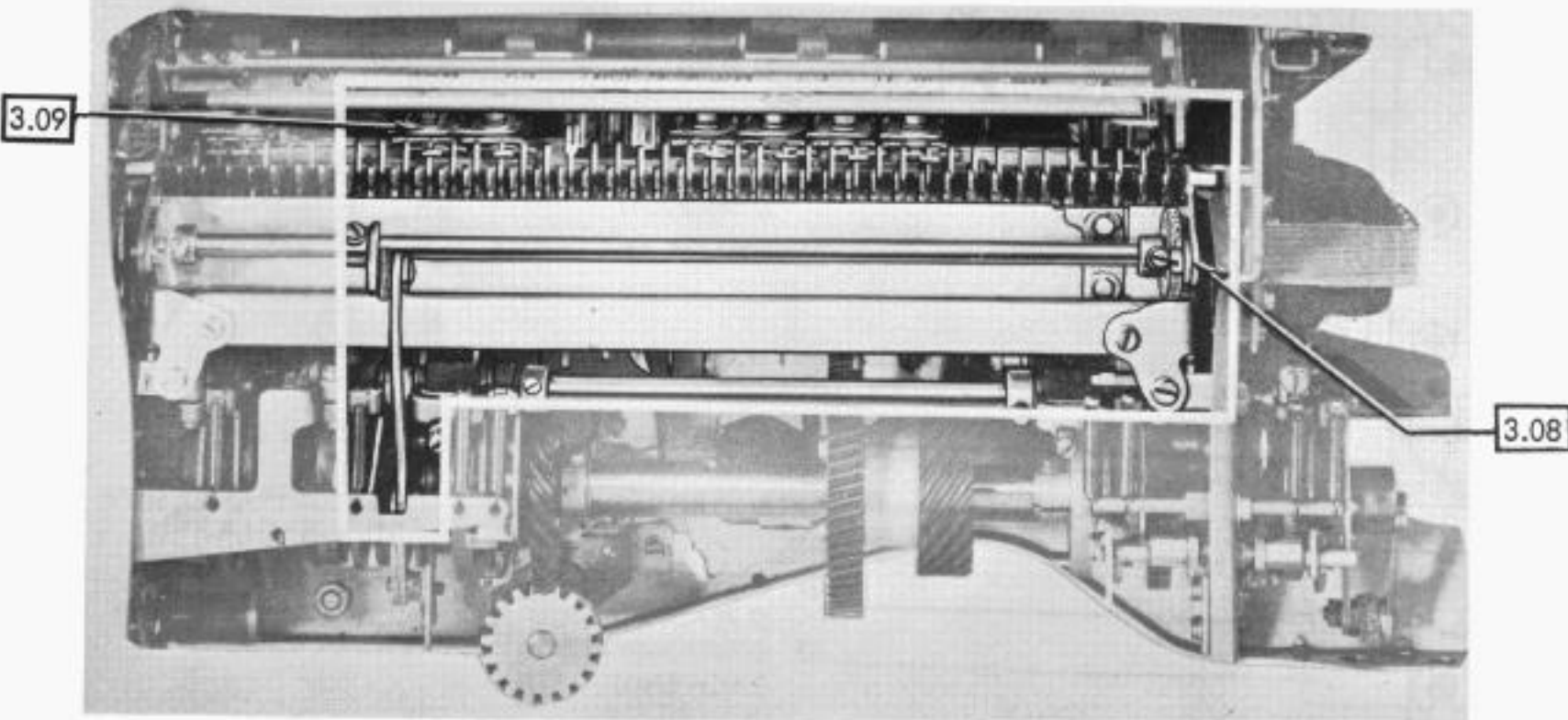

3.08 Stripper Bail Mechanism

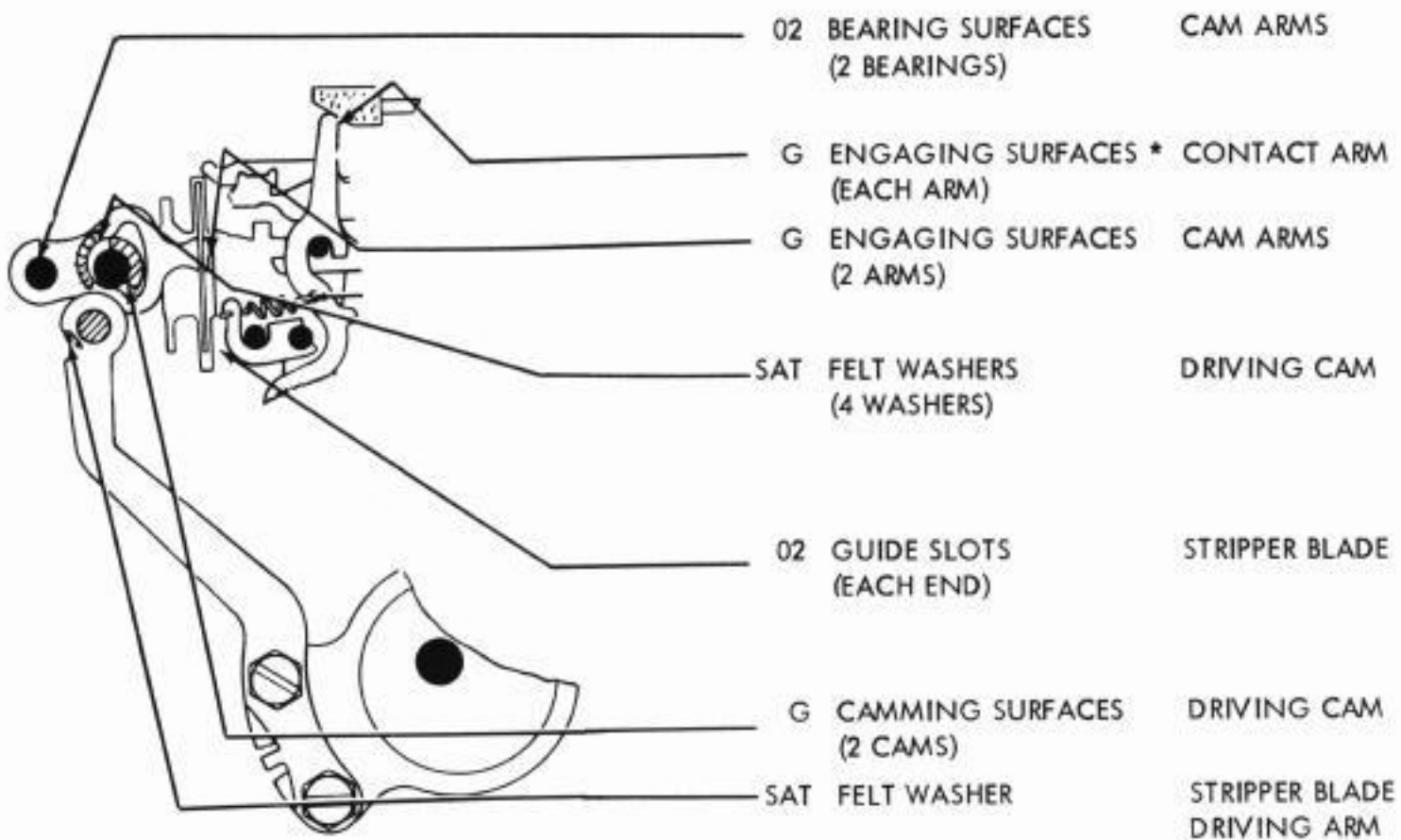

(LEFT SIDE VIEW)

* APPLY LIGHT FILM OF GREASE AND WIPE OFF SURPLUS WITH CLOTH. LUBRICATION IS REQUIRED ON INITIAL BREAK-IN ONLY.

3.09 Shift and Stripper Bail Mechanisms

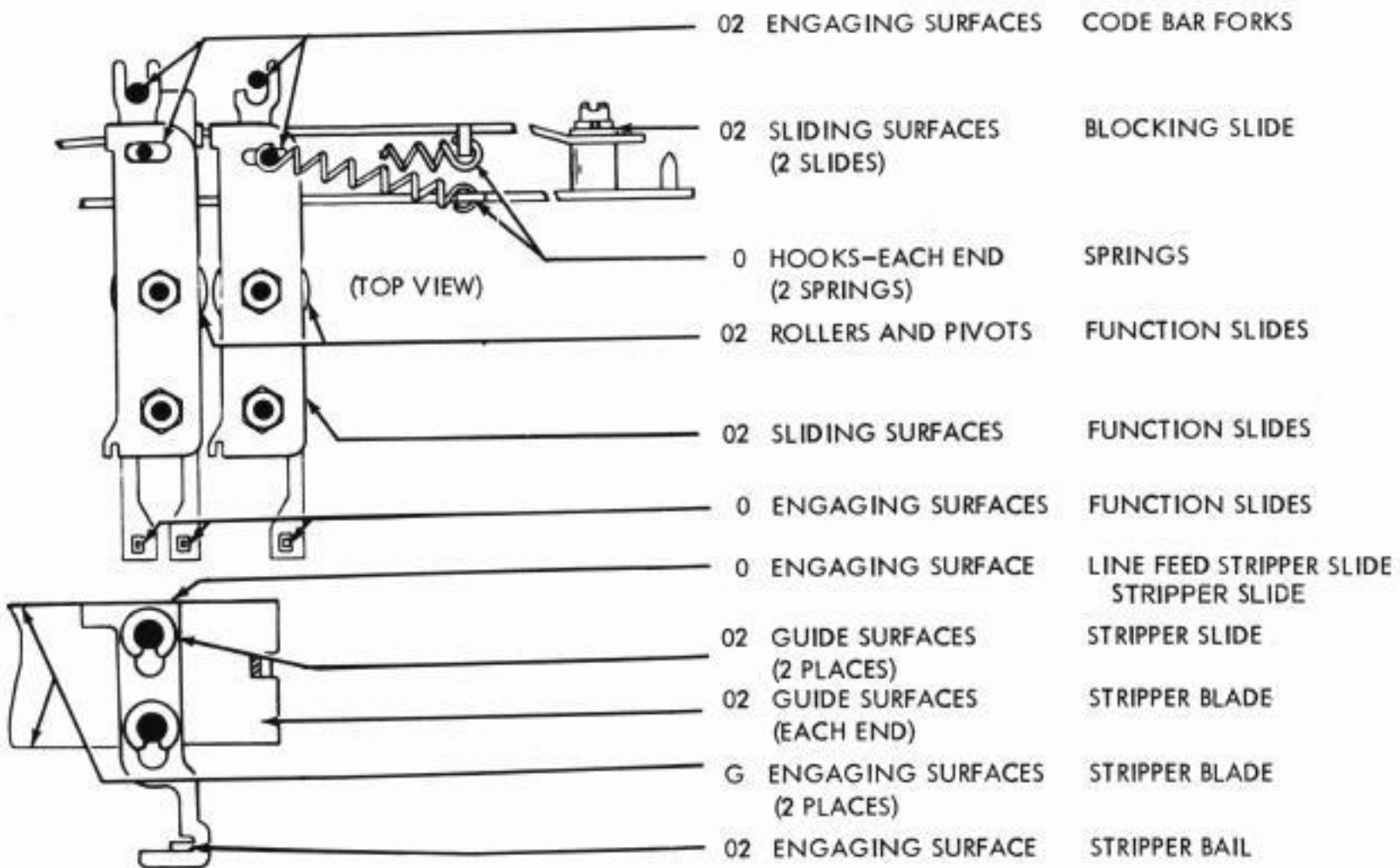

(REAR VIEW)

3.10 Typing Unit - Rear View - Stunt Box Removed

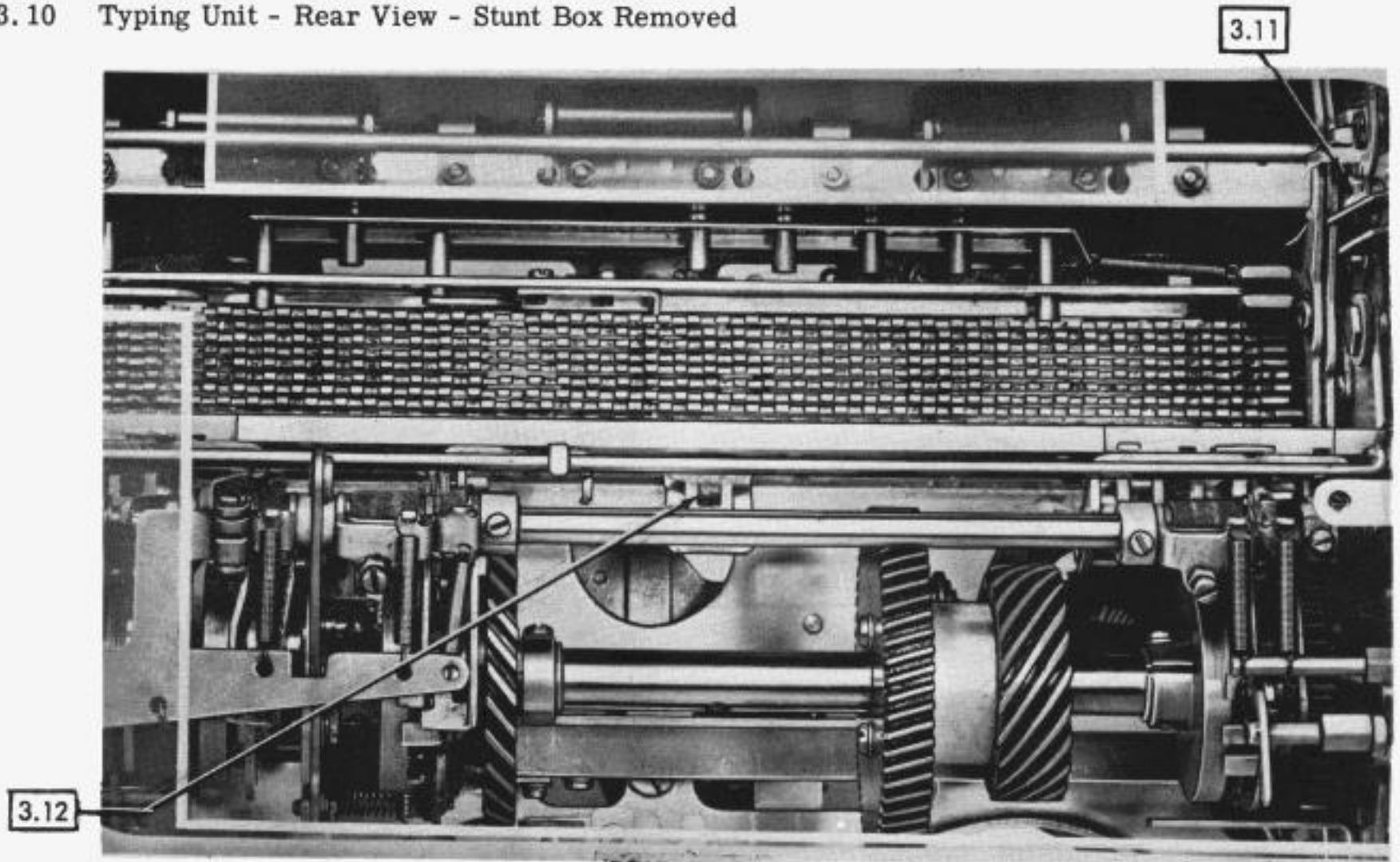

3.11 Single-Double Line Feed Mechanism

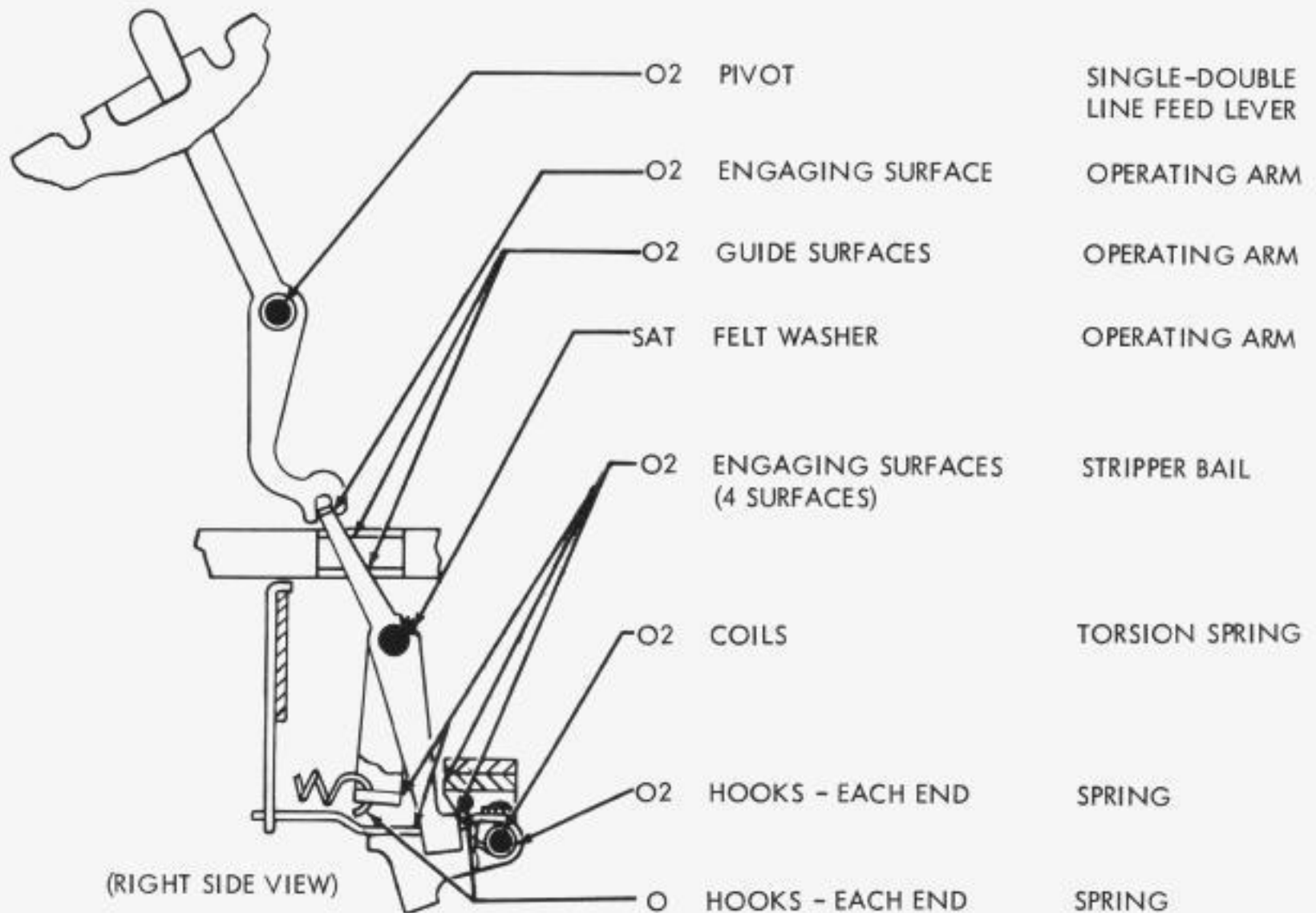

3.12 Function Reset Bail Mechanism

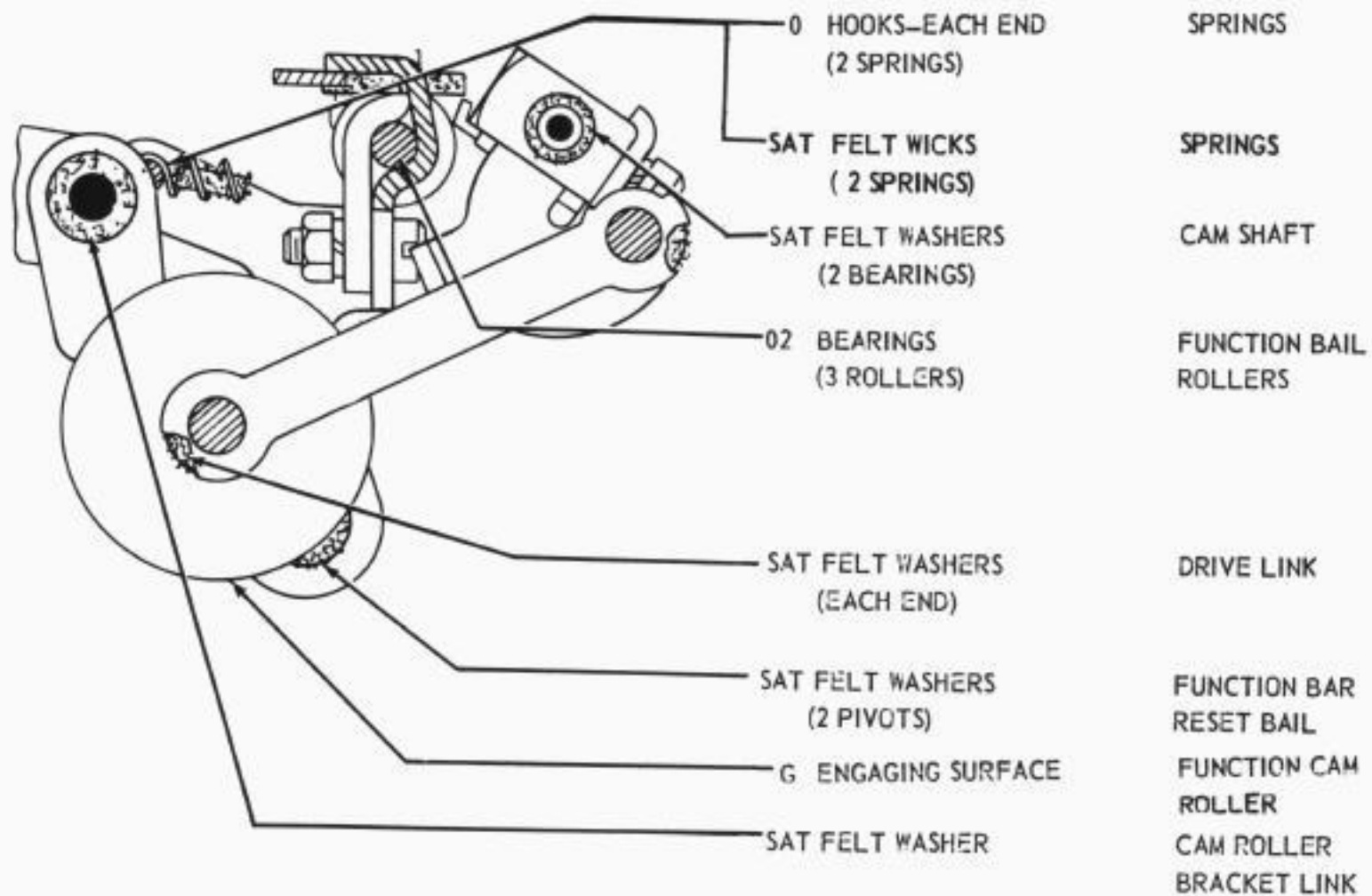

3.13 Typing Unit - Left End View

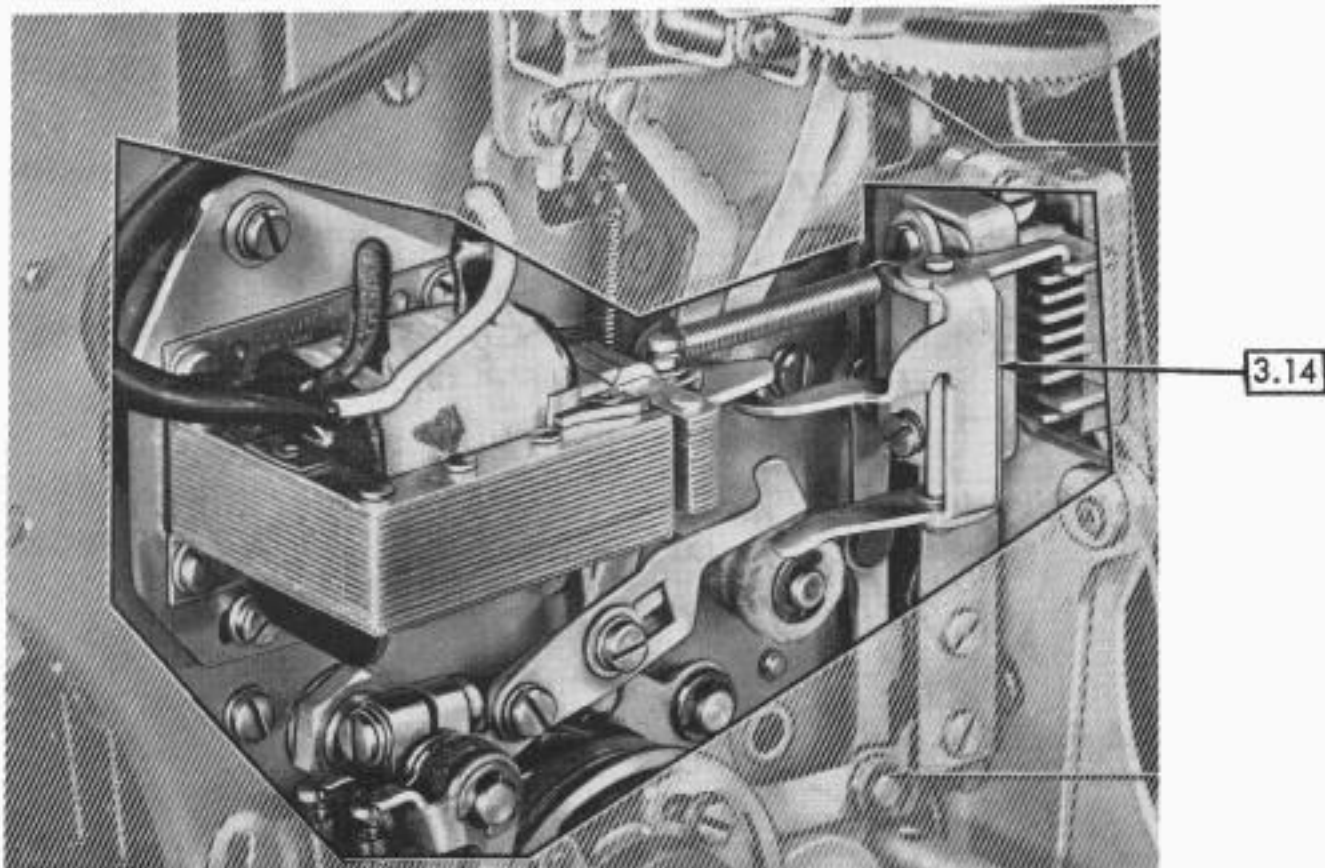

3.14 Clutch Suppression Mechanism

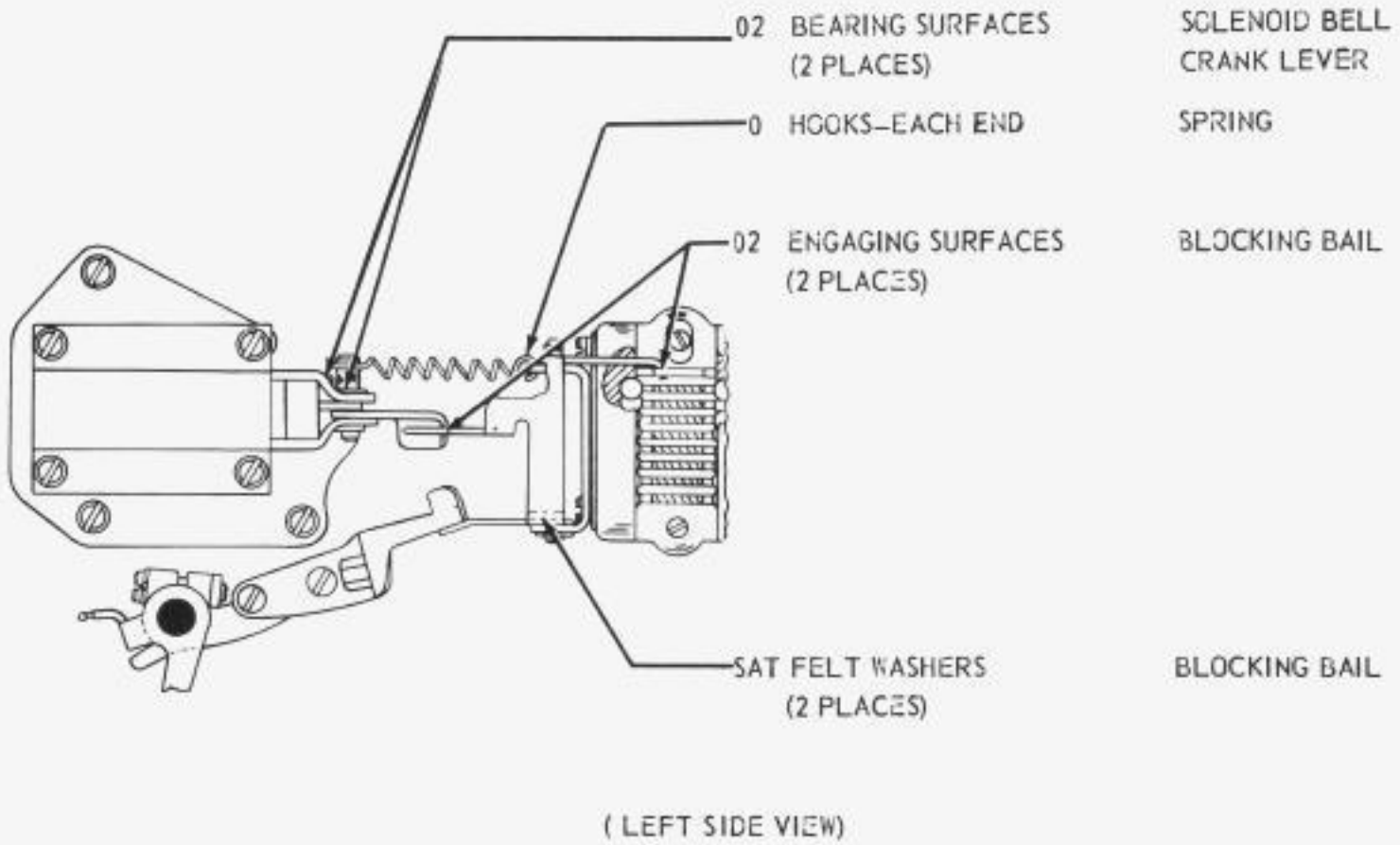

LOCAL BACKSPACE MECHANISM

3.15 Typing Unit - Front View

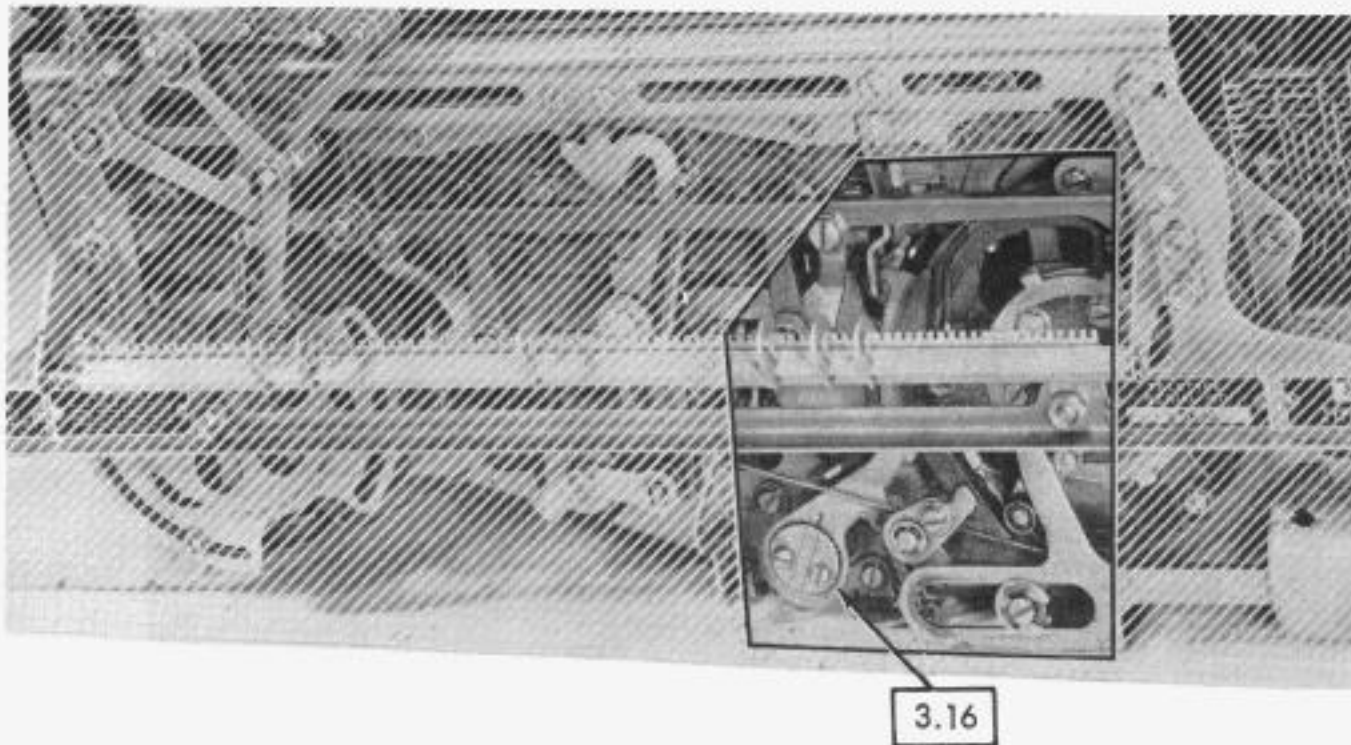

3.16 Pawl Mechanism

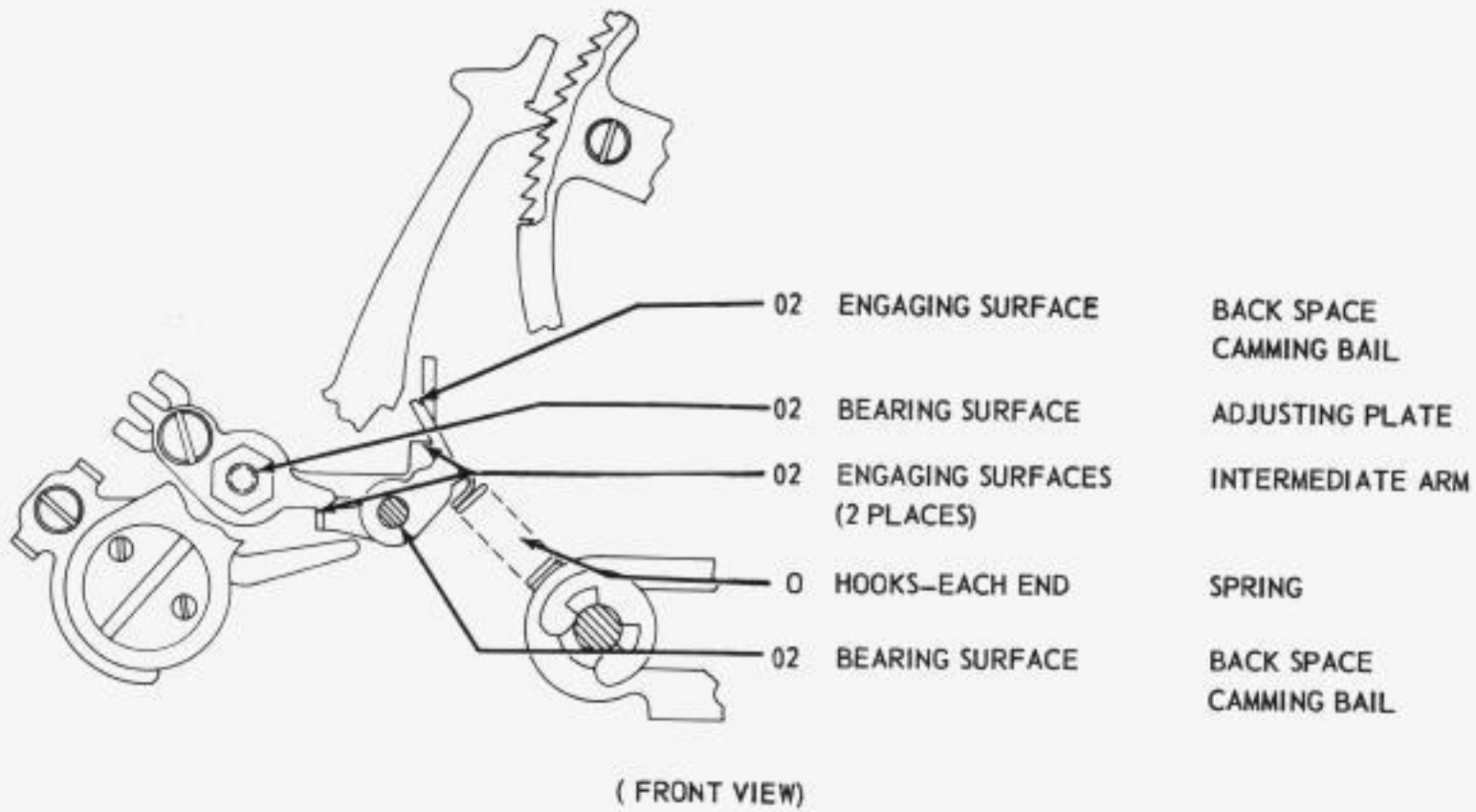

REVERSE LINE FEED MECHANISM

3.17 Typing Unit - Bottom View

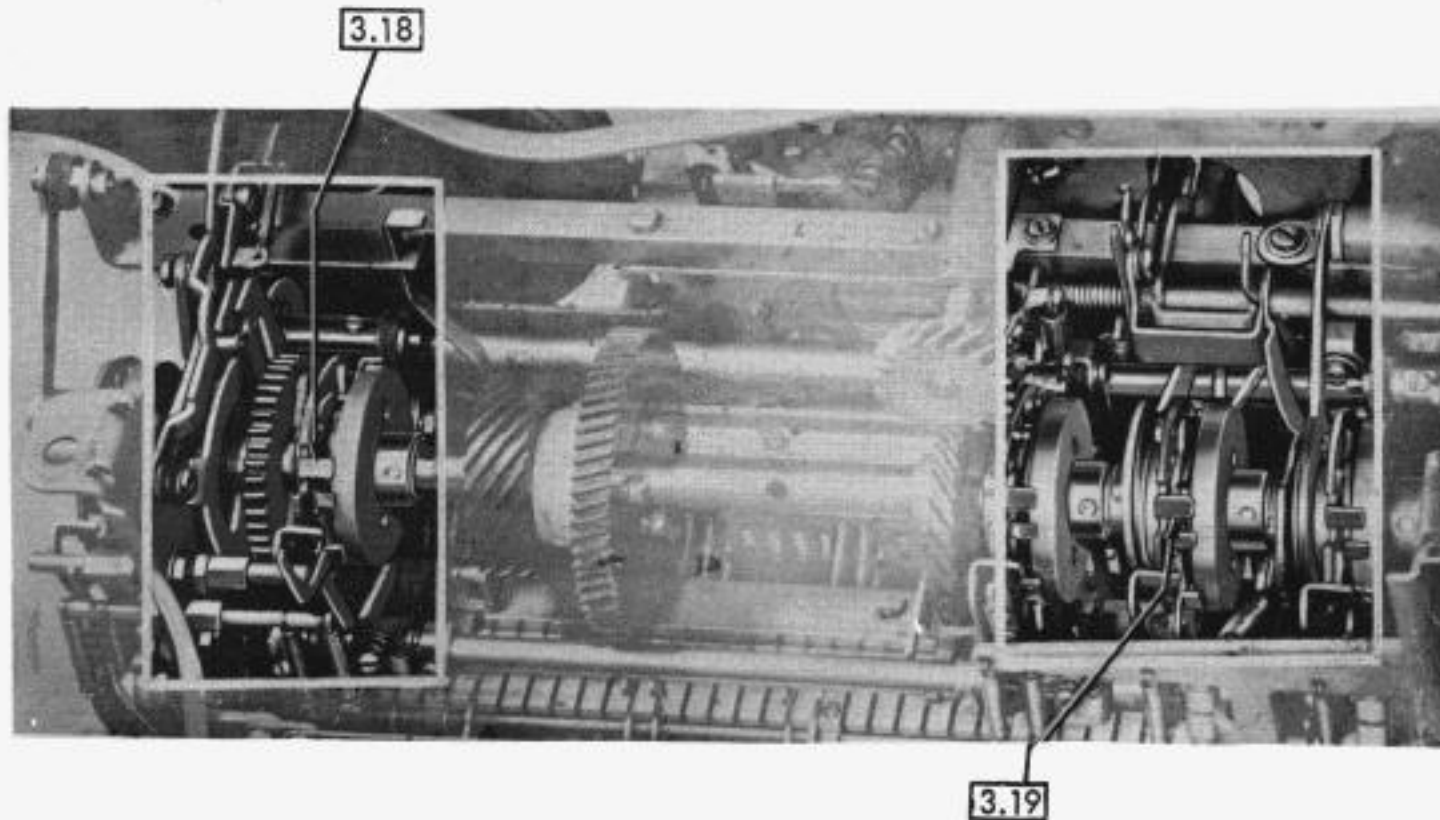

3.18 Trip Mechanism

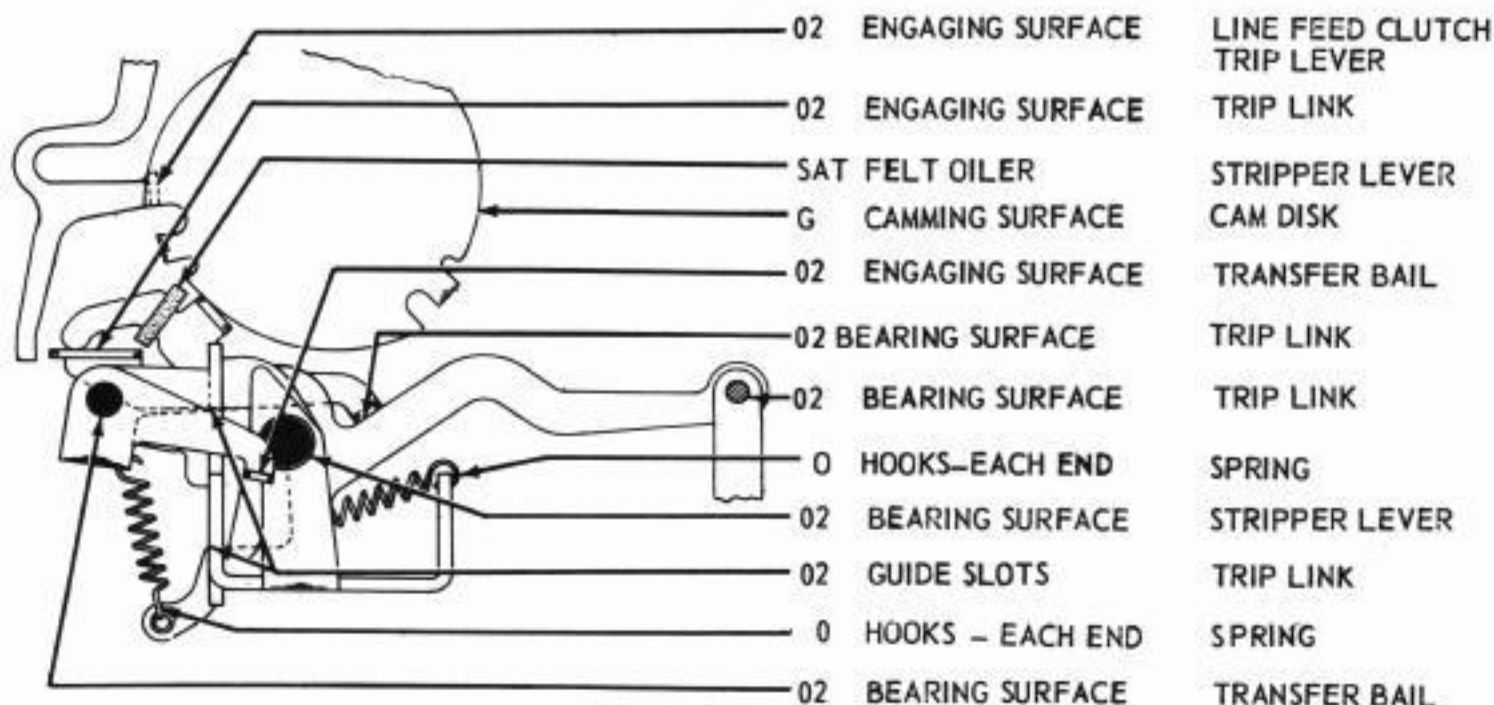

(LEFT SIDE VIEW)

LOCAL BACKSPACE MECHANISM (Cont'd)

3.19 Trip Mechanism

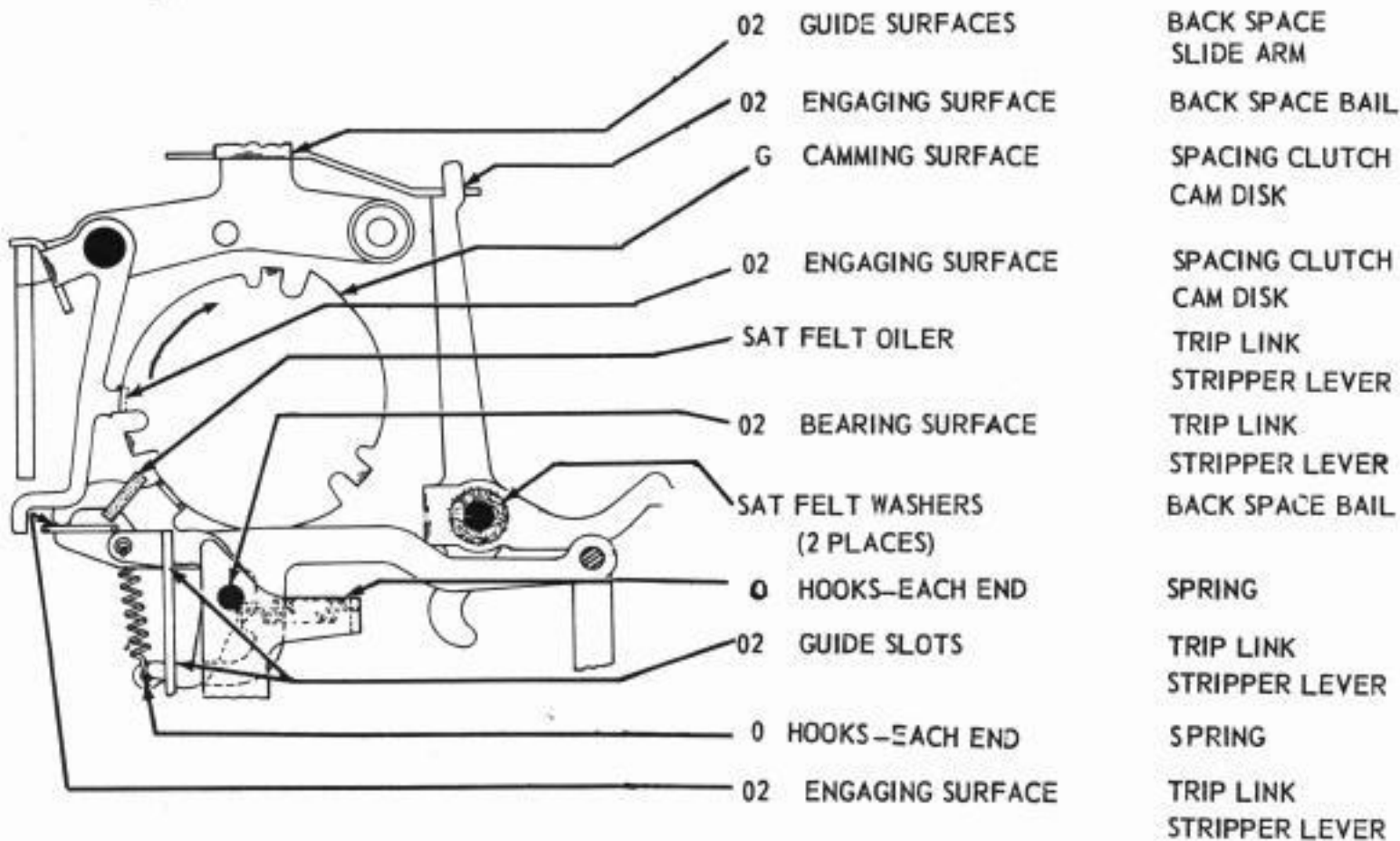

(LEFT SIDE VIEW)

REVERSE LINE FEED MECHANISM (Cont'd)

3.20 Typing Unit - Rear Left View

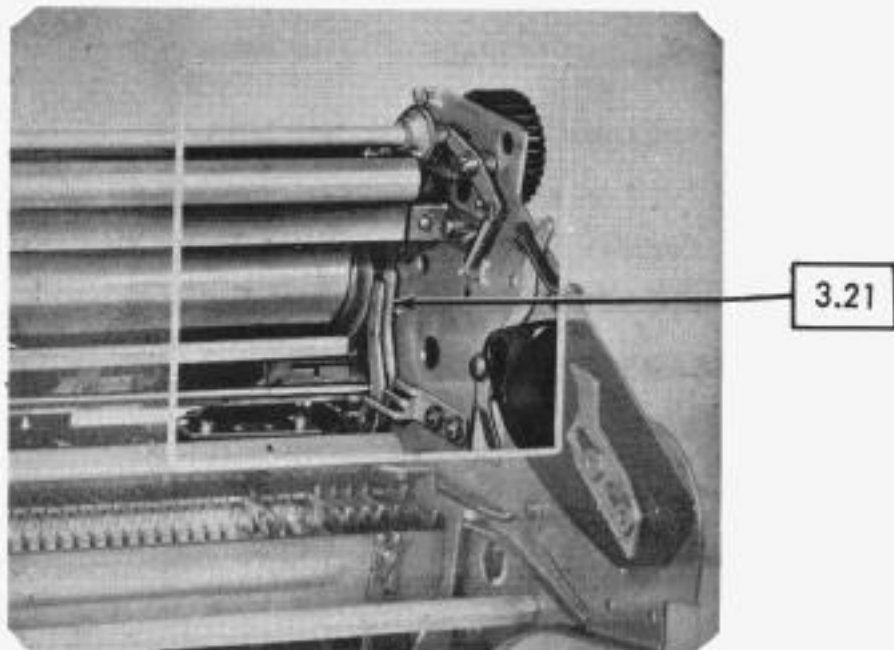

3.21 Line Feed Mechanism

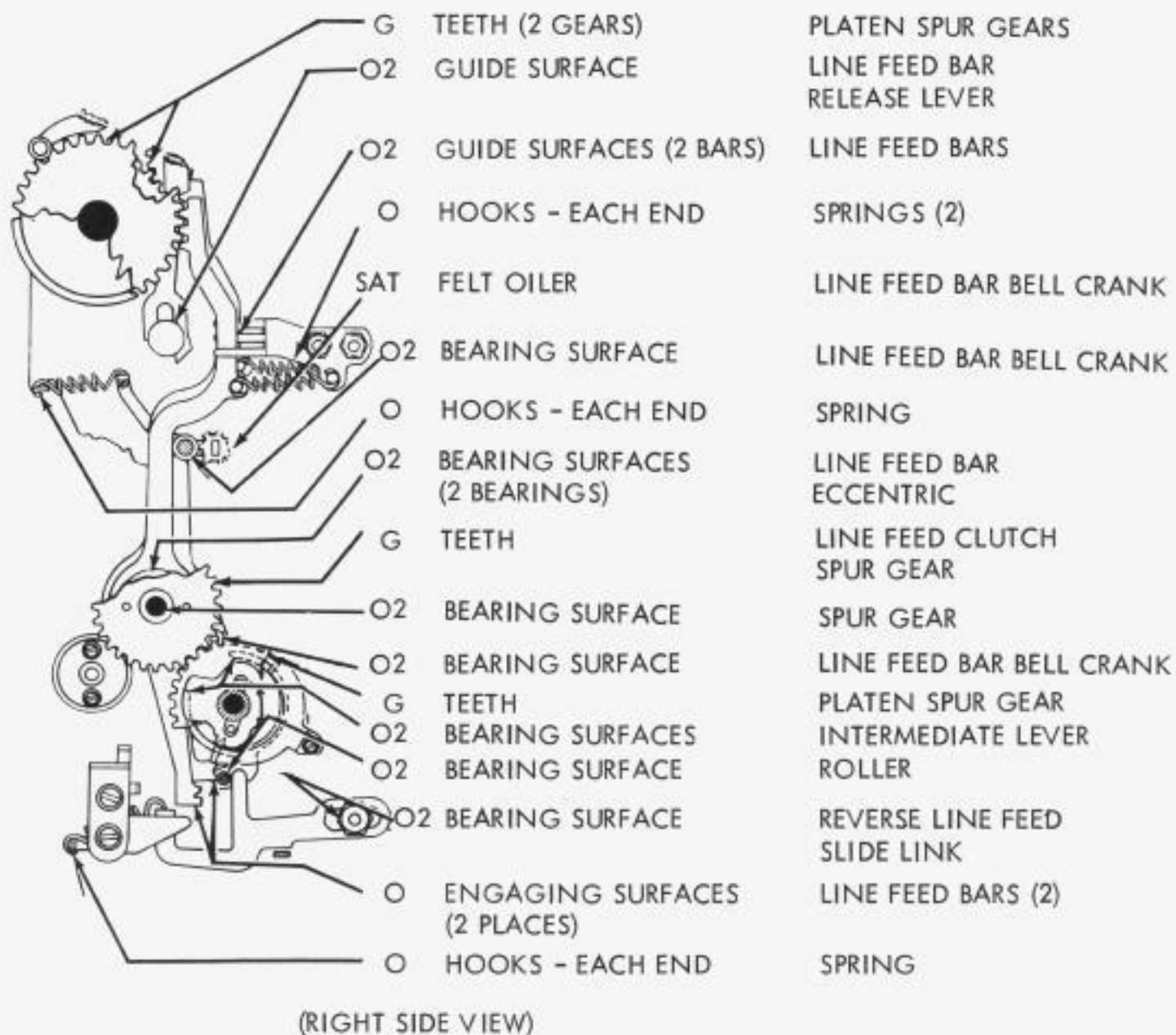

PAGE FEED-OUT MECHANISM

3.22 Typing Unit - Rear Left End View

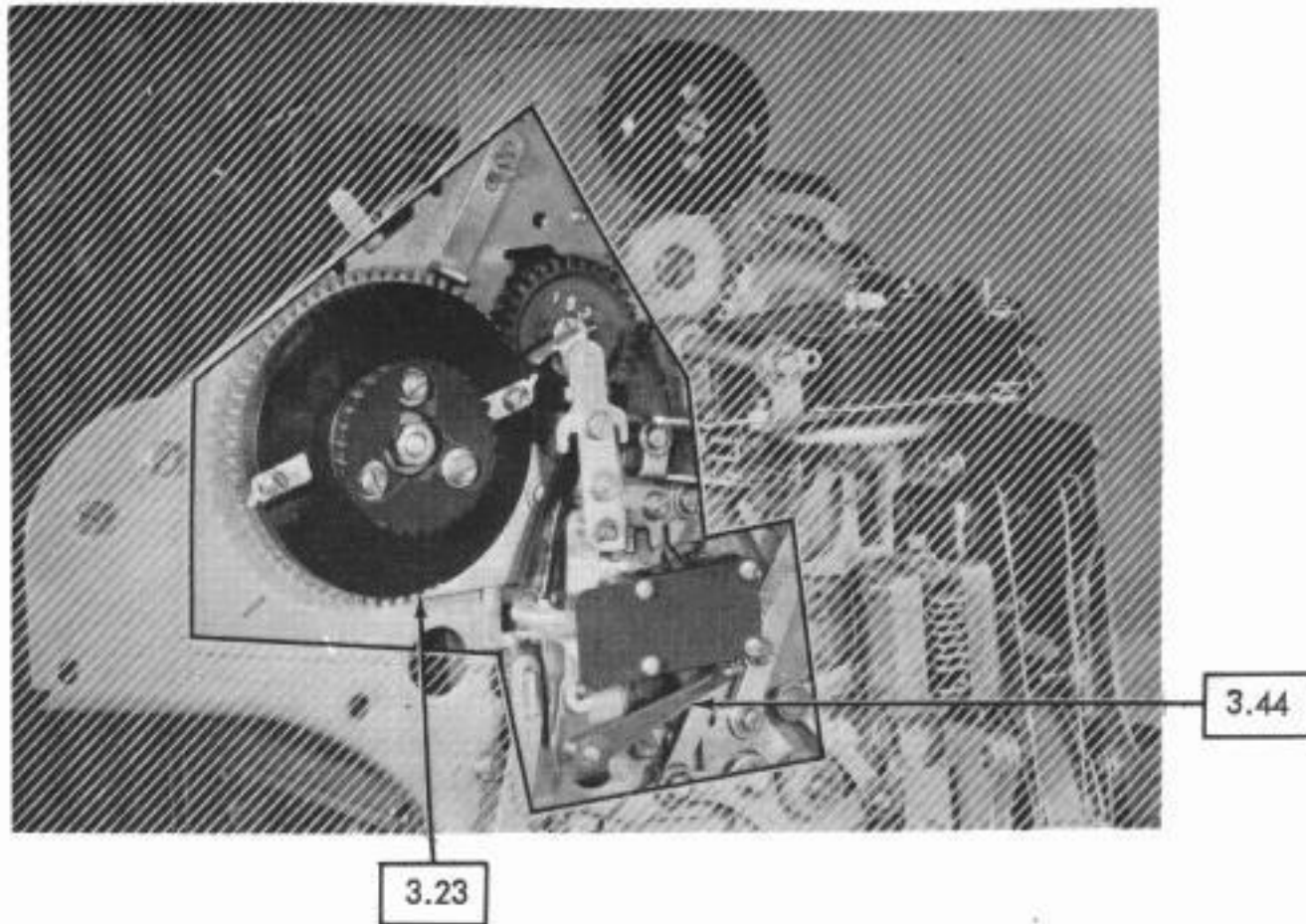

3.23 Drive Mechanism

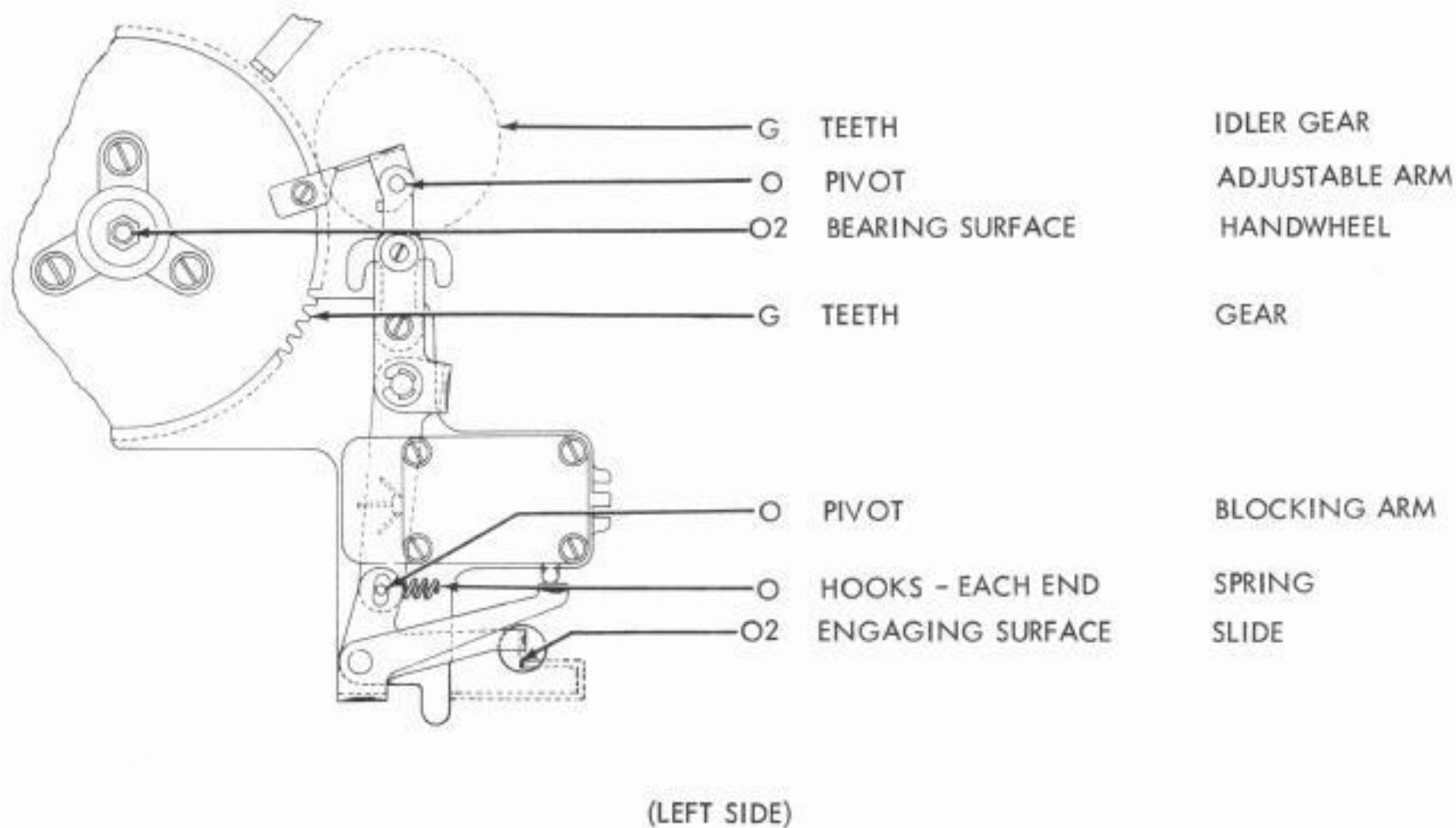

PAPER-OUT ALARM MECHANISM

3.24 Operating Mechanism

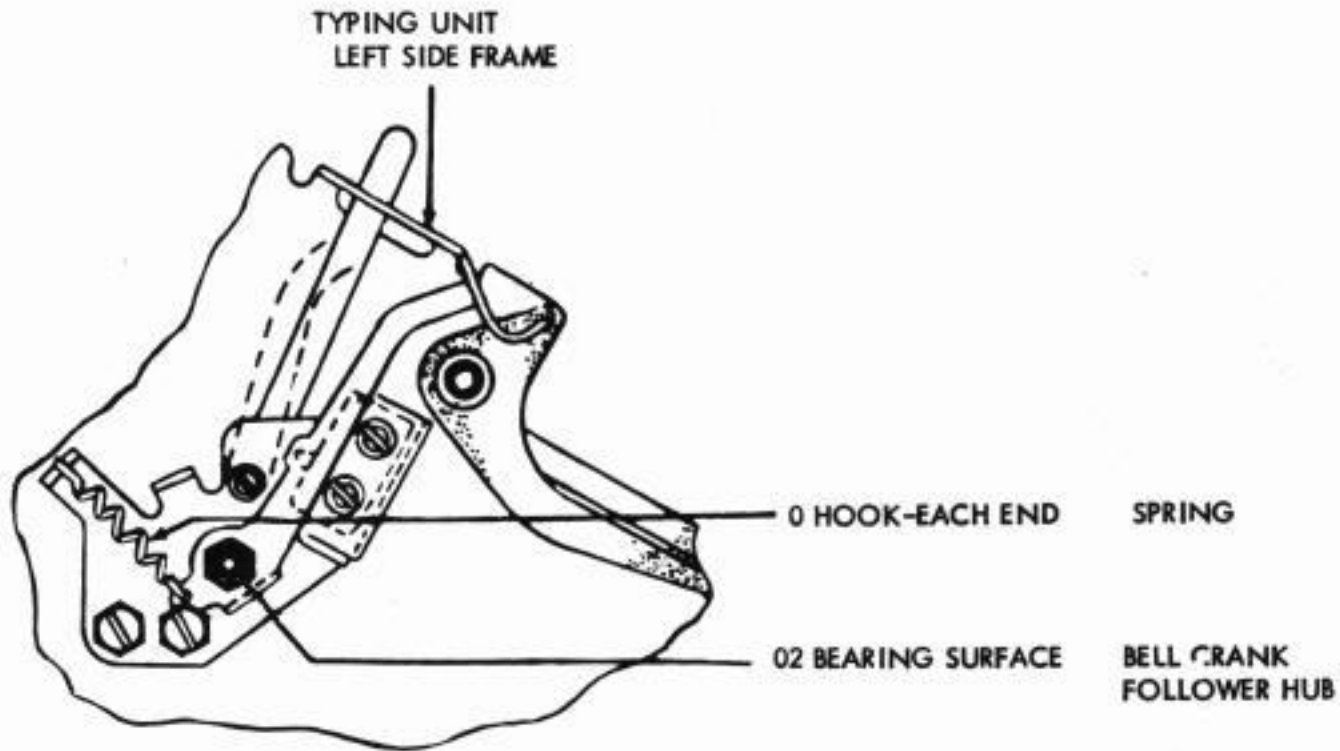

CONTINUOUS SPACING MECHANISM

3.25 Trip Mechanism

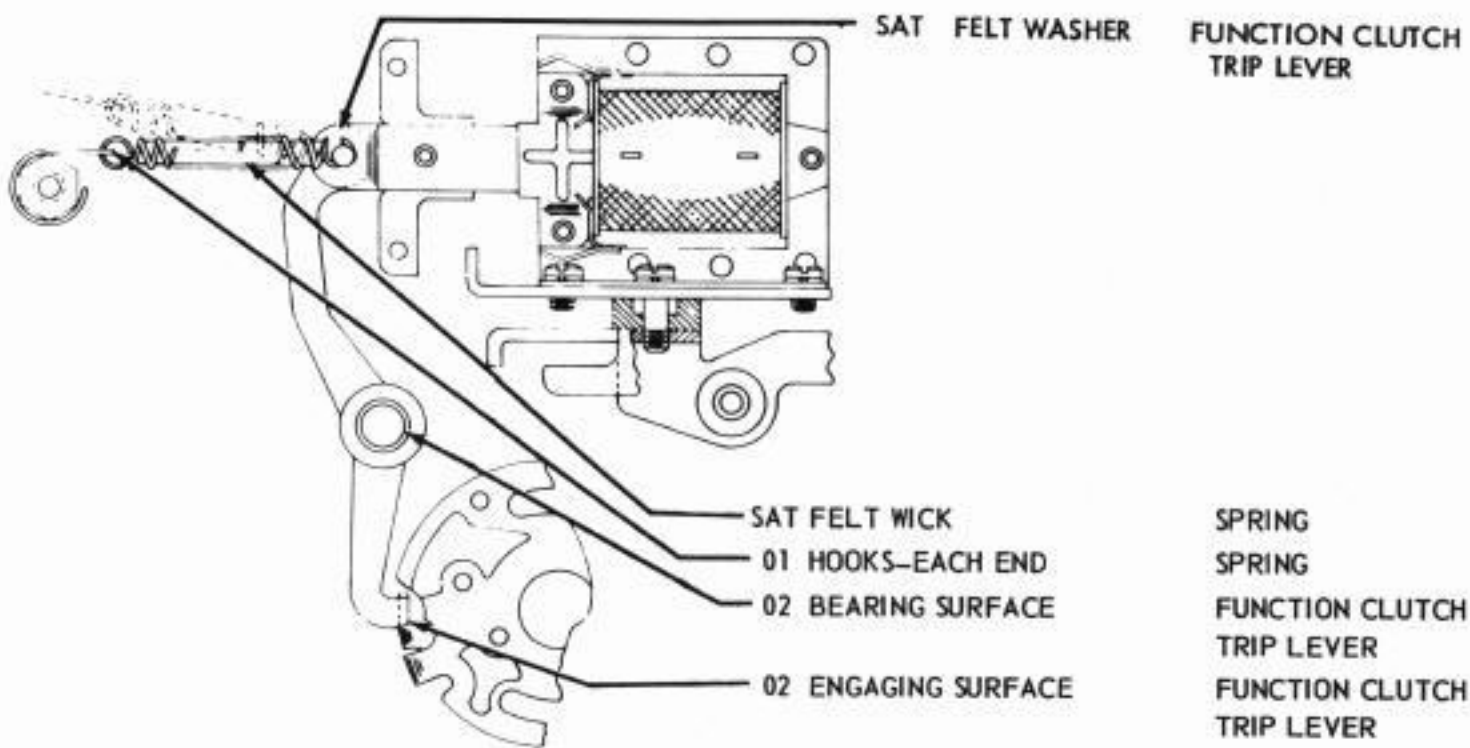

3.26 Slide Arm Bracket

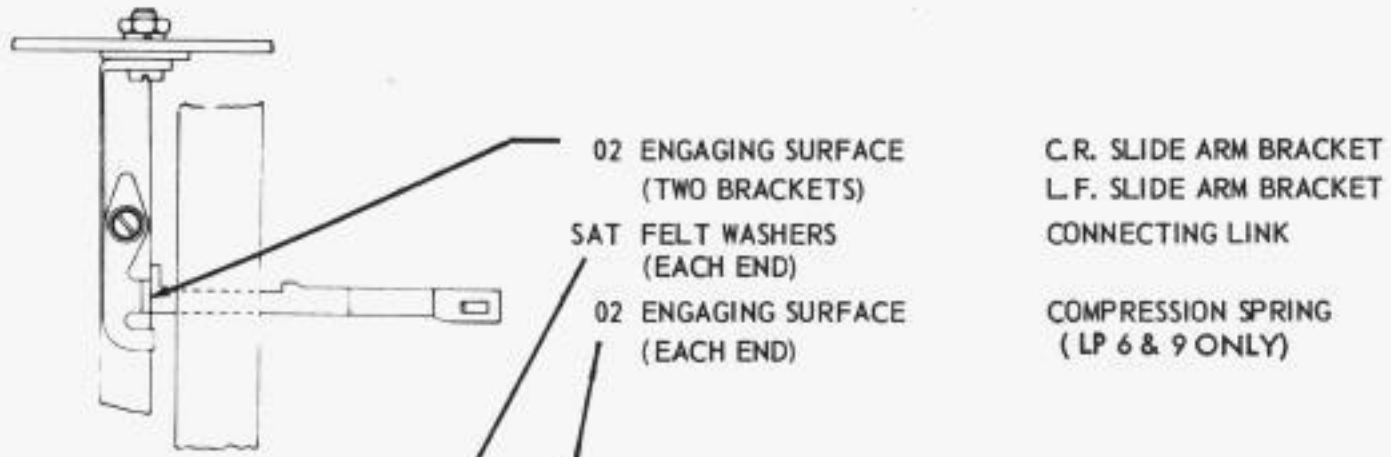

3.27 Compression Spring

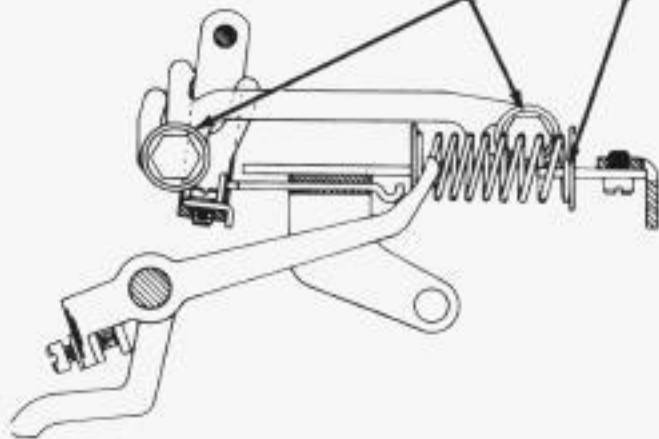

3.28 Typing Unit - Rear View

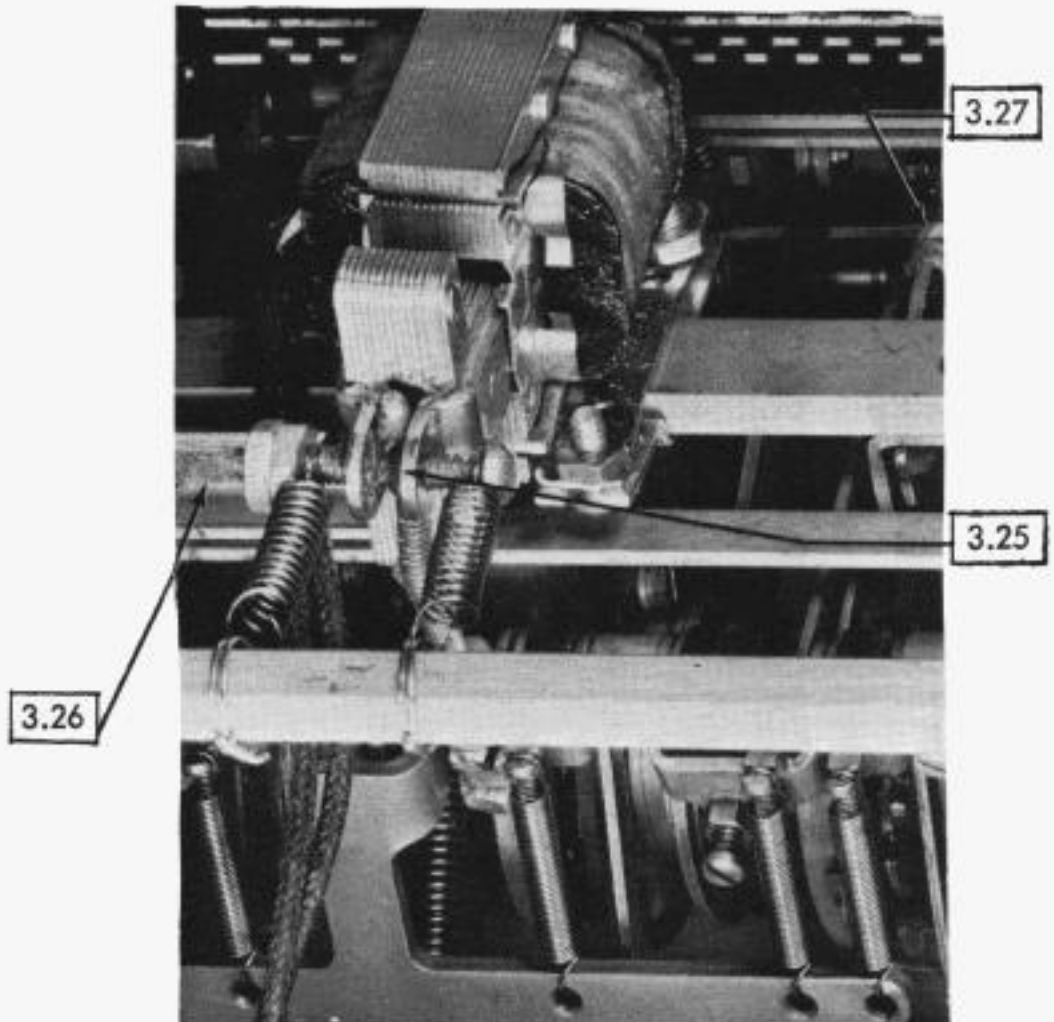

HORIZONTAL TABULATOR MECHANISM - LATER DESIGN

3.29 Typing Unit - Front View

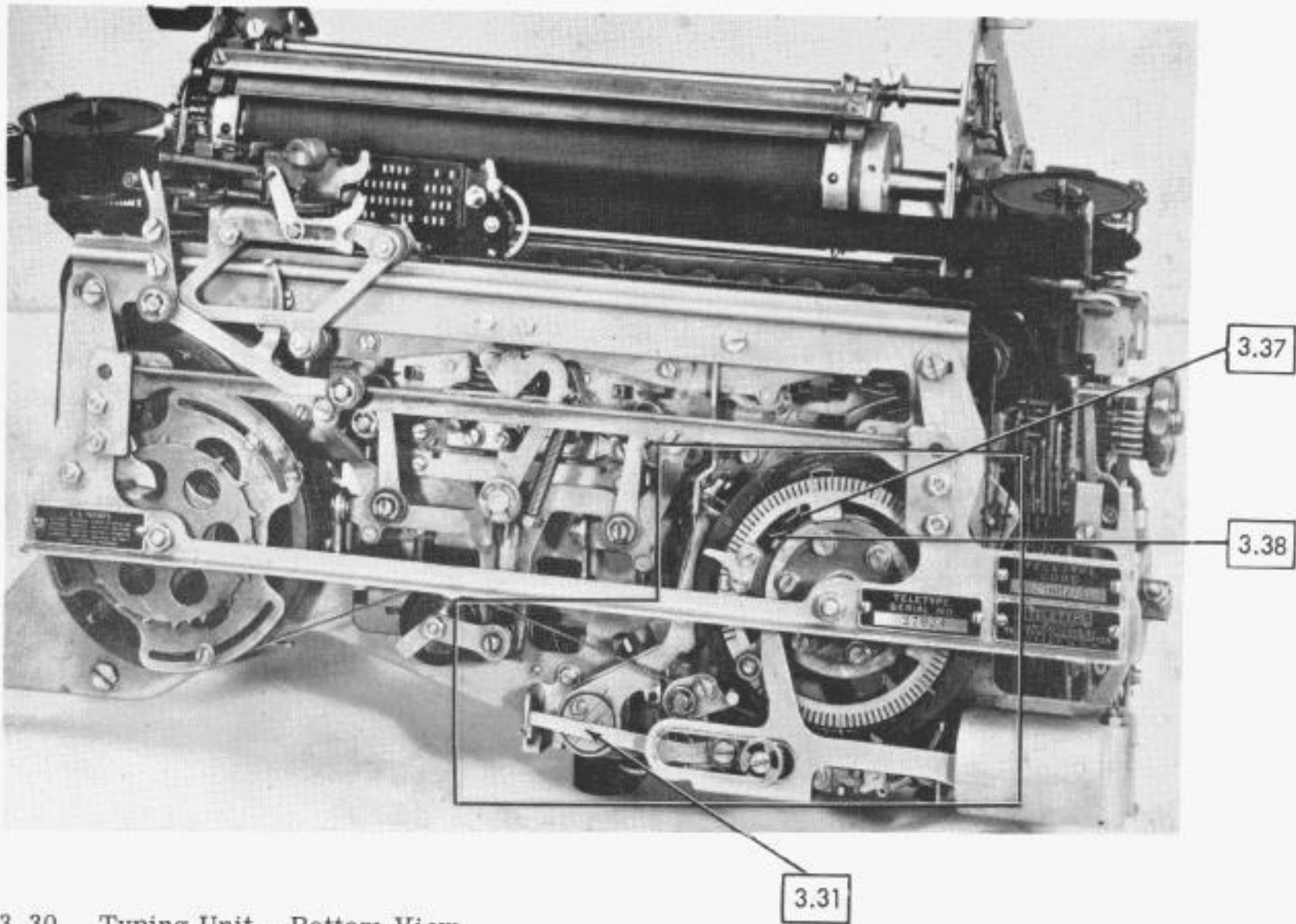

3.30 Typing Unit - Bottom View

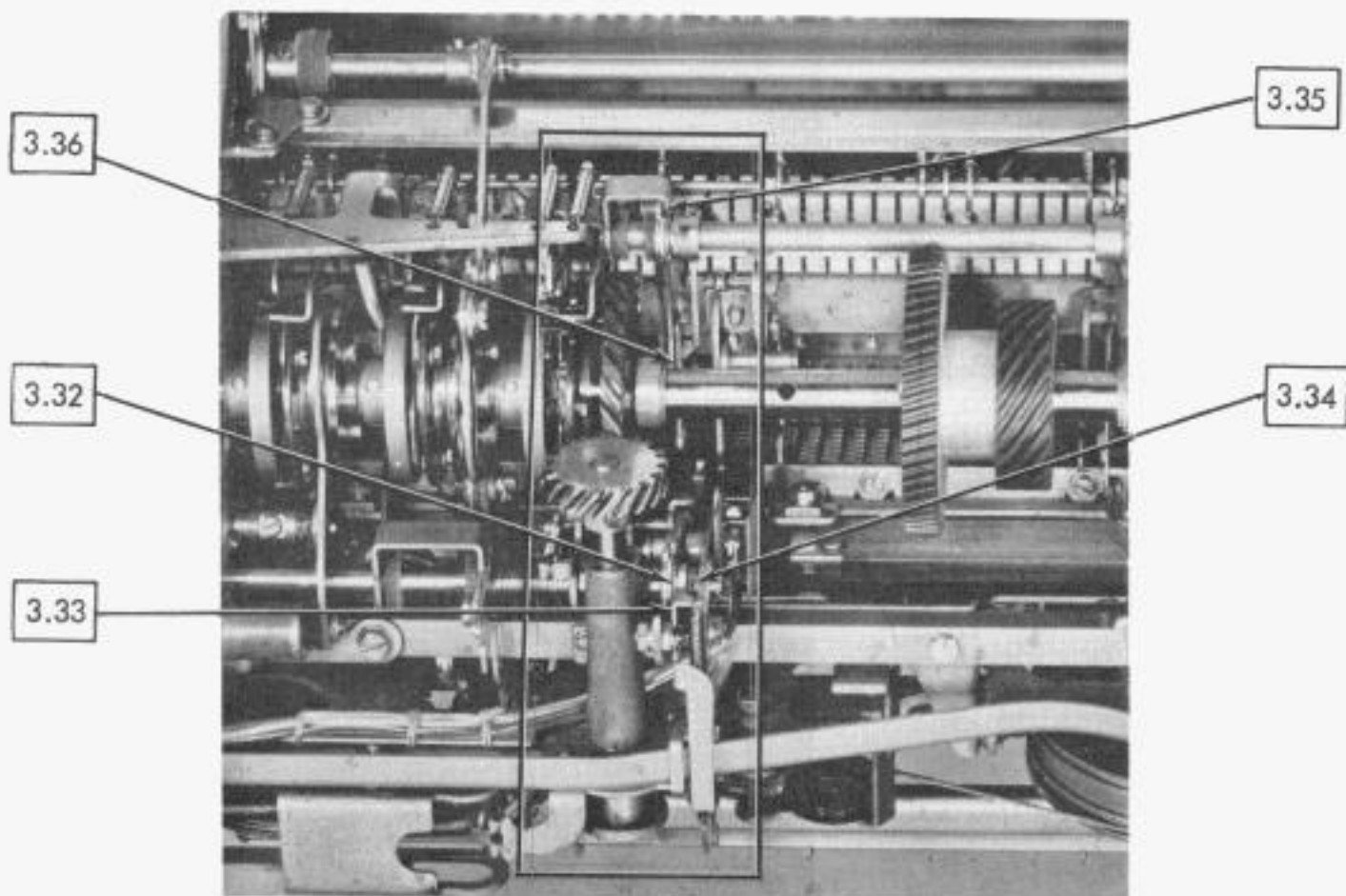

3.31 Blocking Lever

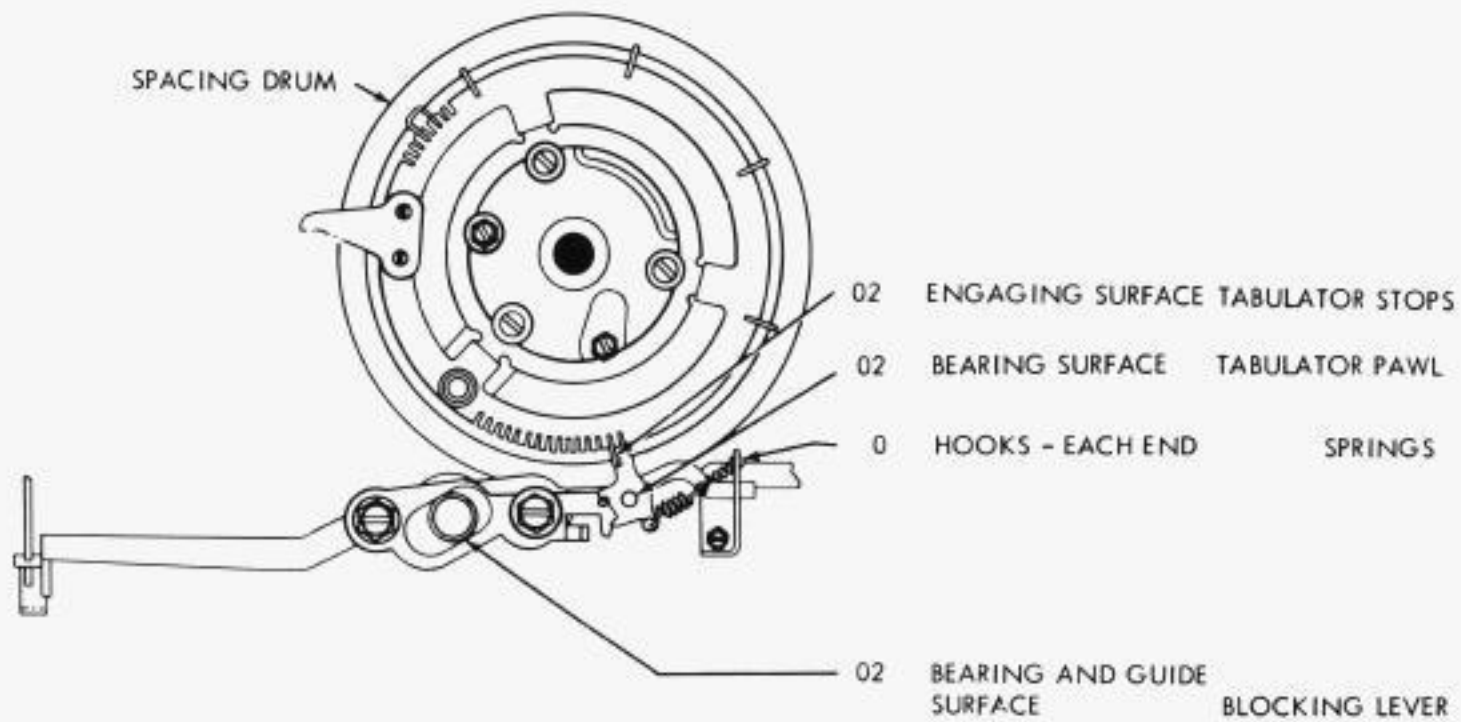

3.32 Slide Arm

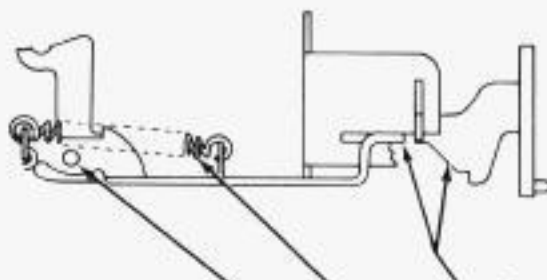

02 ENGAGING SURFACE WITH BLOCKING LEVER AND BRACKET OPERATING LEVER SLIDE ARM

3.33 Operating Lever

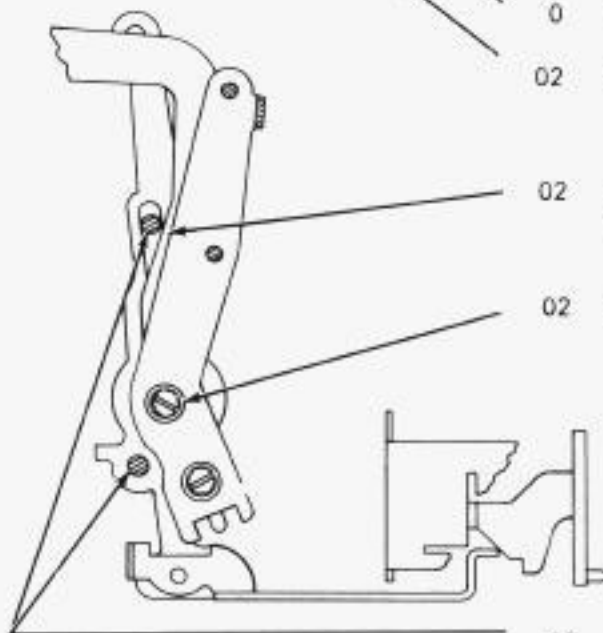

0 HOOKS - EACH END SLIDE ARM SPRING

02 BEARING SURFACE OPERATING LEVER SLIDE ARM

02 CONTACTING SURFACE WITH ADJUSTING PLATE OPERATING LEVER

02 BEARING SURFACE TRIP LEVER ARM LATCH BAIL

02 BEARING SURFACE OPERATING LEVER

3.34 Latch Bail

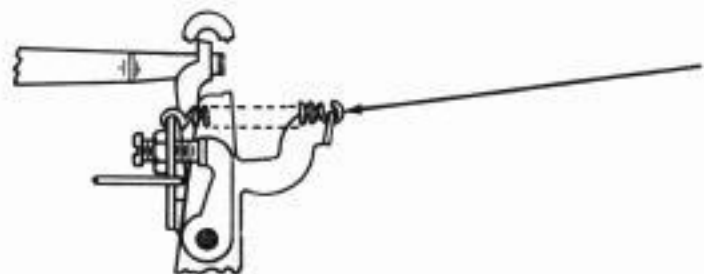

0 HOOKS - EACH END LATCH BAIL SPRING

3.35 Operating Lever

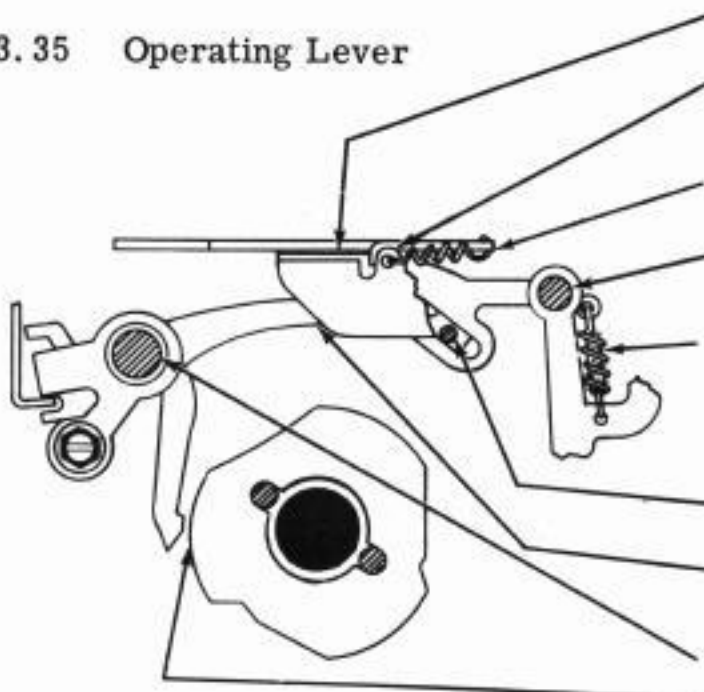

02 GUIDE SURFACES OPERATING LEVER
 02 CONTACT WITH SLIDE ARM OPERATING LEVER
 0 HOOKS - EACH END SLIDE ARM SPRING
 02 BEARING SURFACE OPERATING LEVER
 SAT FELT WICK SPRING
 02 SLOT CAMMING SURFACE OPERATING LEVER
 02 BRACKET CONTACT SURFACE OPERATING LEVER
 SAT FELT WASHERS STRIPPER BAIL SHAFT
 G CAMMING SURFACE SPACING CLUTCH RESTORING CAM

3.36 Intermediate Bail

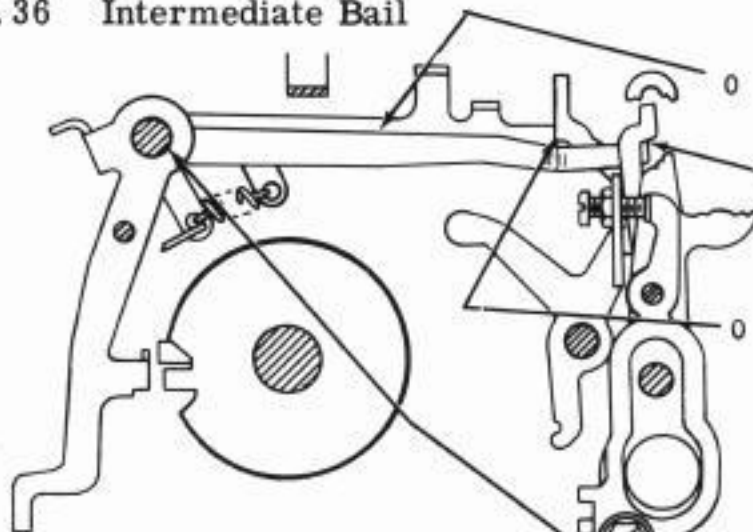

0 CONTACT SURFACE TRIP LEVER ARM INTERMEDIATE BAIL
 02 CONTACTING SURFACE SPACING TRIP LEVER ARM
 0 CONTACT SURFACE SPACING TRIP LEVER INTERMEDIATE BAIL

3.37 Spacing Cut-Out Transfer Bail

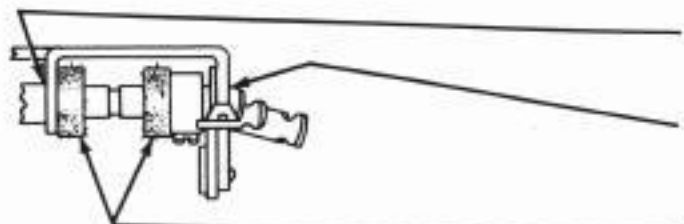

SAT FELT WASHER TRIP LEVER ARM SHAFT
 02 BEARING SURFACE SPACING CUTOUT TRANSFER BAIL
 02 BAIL CONTACTING SURFACE SPACING CUTOUT TRANSFER BAIL
 SAT FELT WASHER TRANSFER BAIL STUD

3.38 Bail Extension Arm

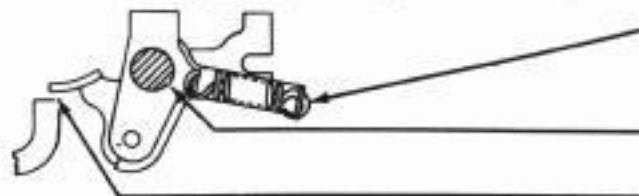

0 HOOKS - EACH END SPACE SUPPRESSION BY PASS SPRING
 02 BEARING SURFACE BAIL EXTENSION ARM
 02 CONTACT SURFACE WITH SPACING CUT-OUT LEVER BAIL EXTENSION ARM

TWO COLOR RIBBON MECHANISM

3.39 Oscillating Lever

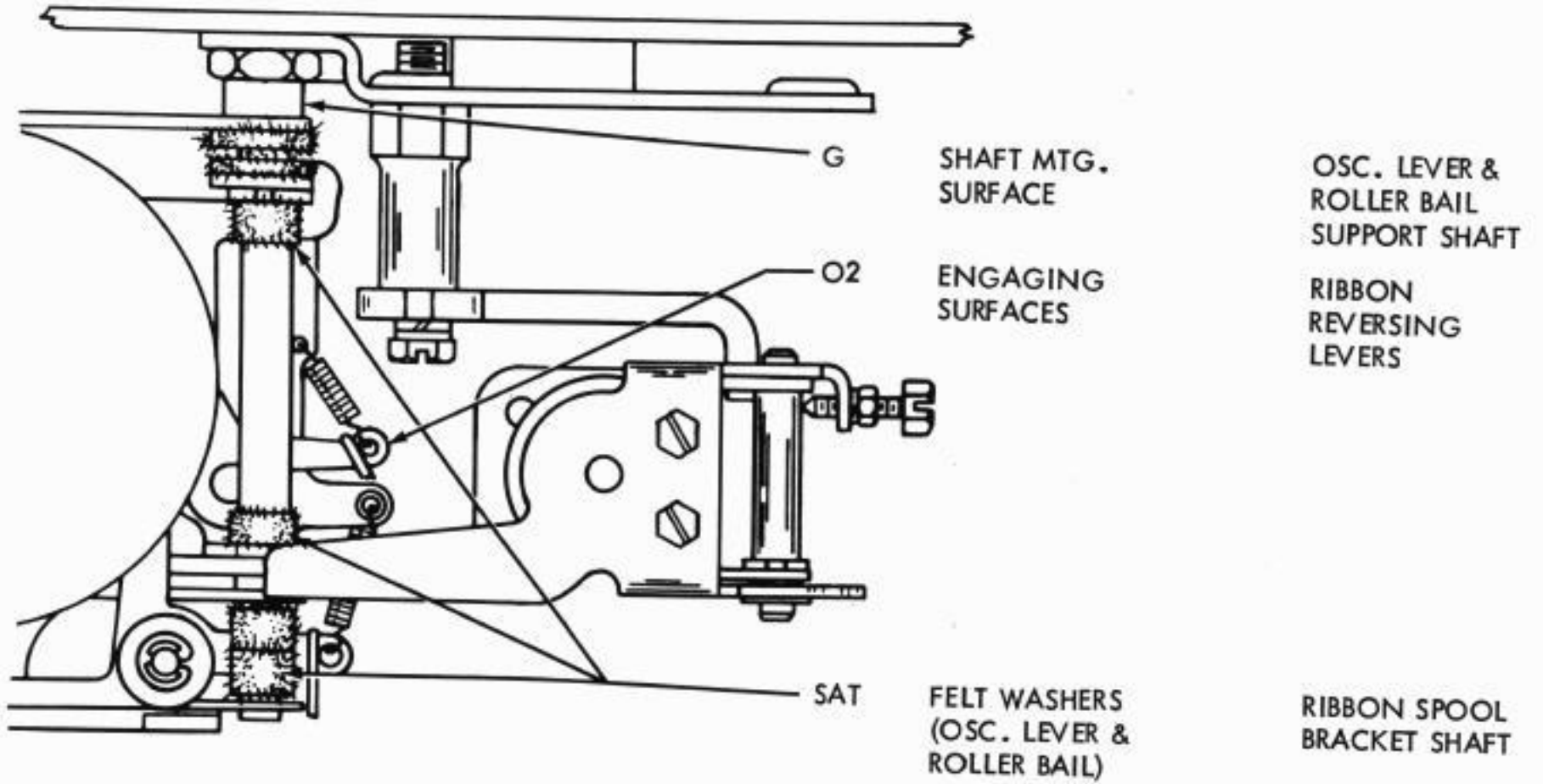

3.40 Ribbon Operating Mechanism

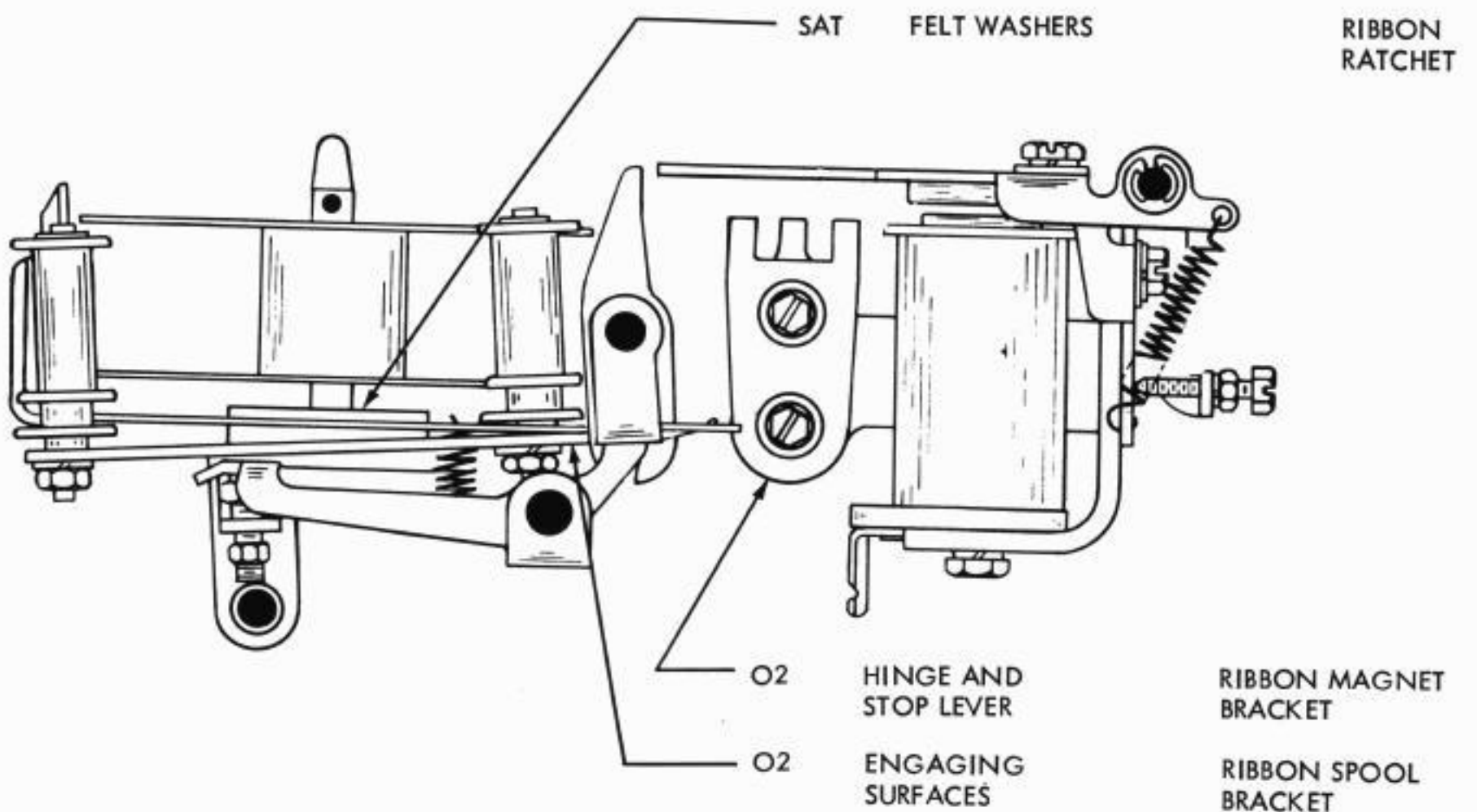

UNIVERSAL CONTACT (STUNT BOX) MECHANISM

3.41 Stunt Box - Rear View

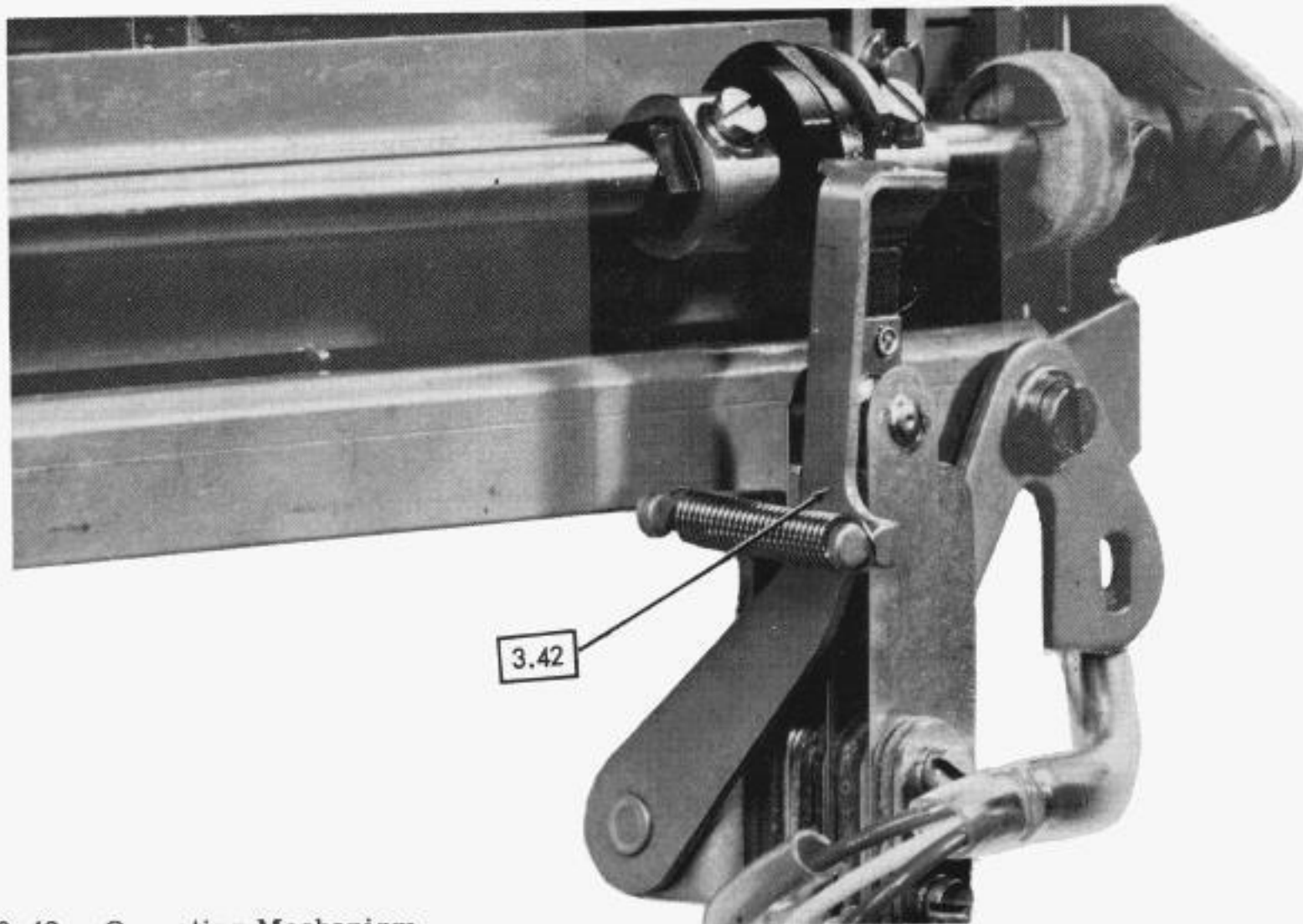

3.42 Operating Mechanism

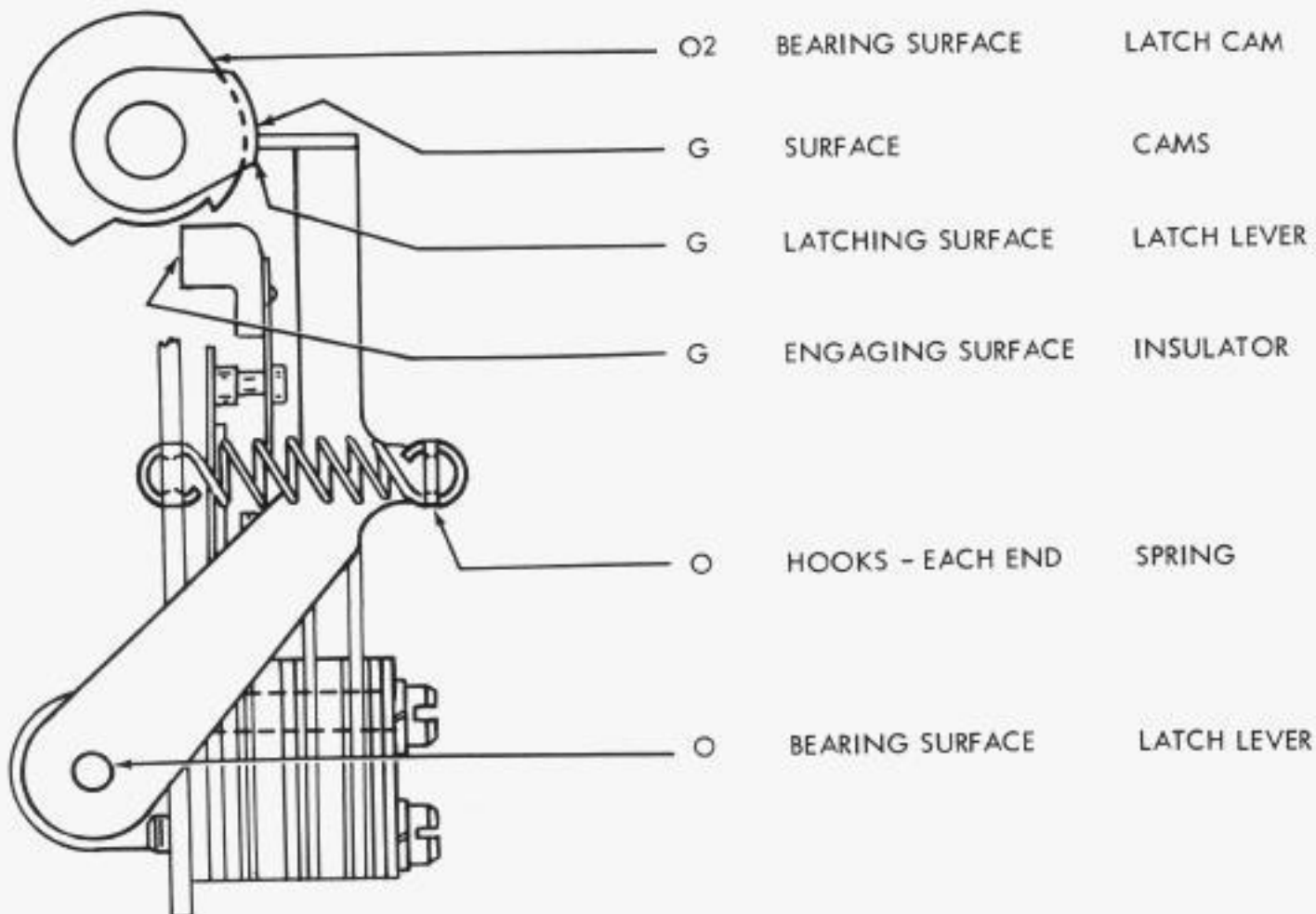

VERTICAL TABULATION AND TRANSMITTER DISTRIBUTOR CONTROL MECHANISM

3.43 Control Mechanism

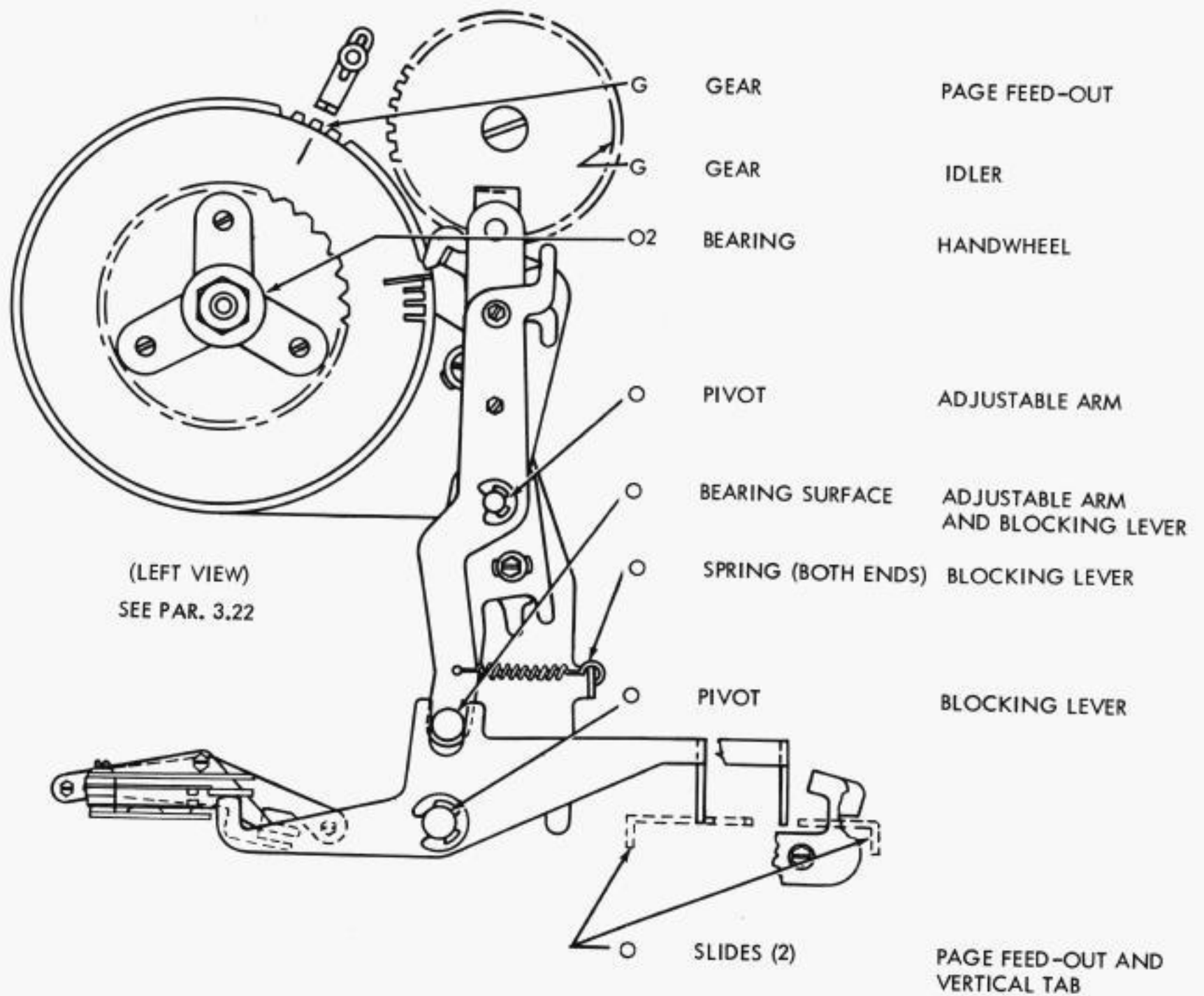

FORM ALIGNMENT SWITCH MECHANISM

3.44 Operating Mechanism

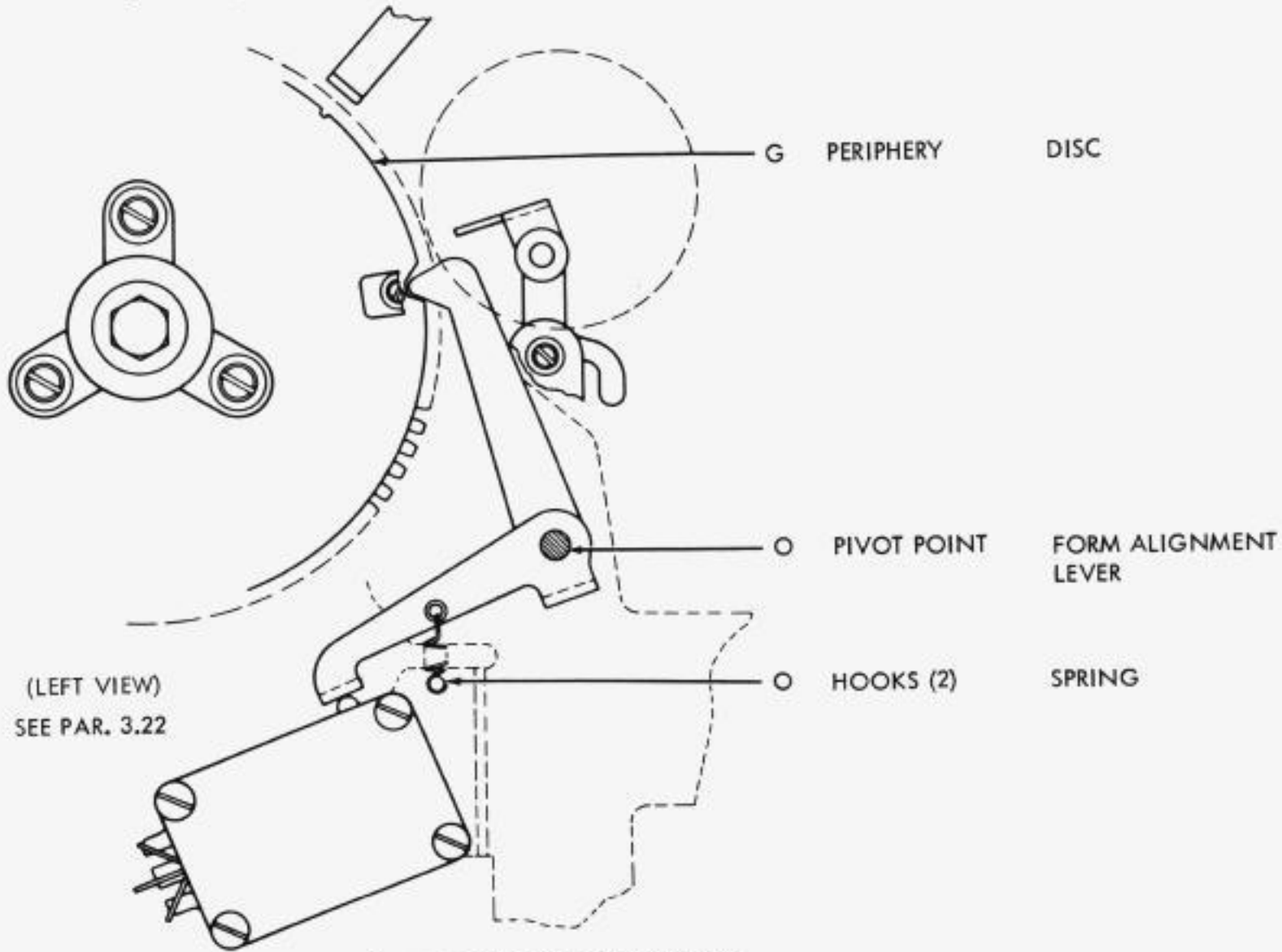

UNIVERSAL CONTACT (SELECTOR) MECHANISM

3.45 Contact Mechanism

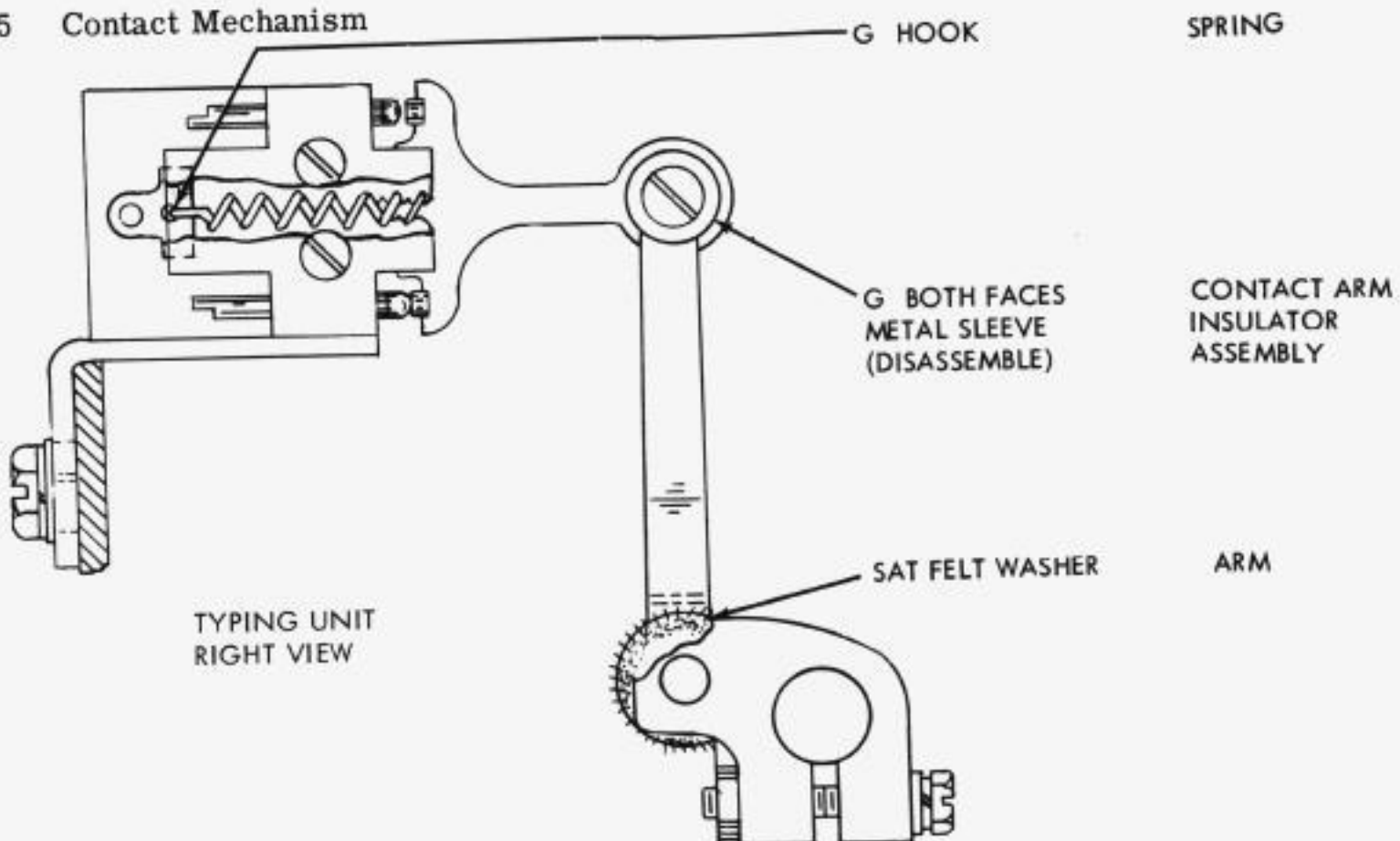

DC MAGNET OPERATED PRINT SUPPRESSION MECHANISM

3.46 Suppression Mechanism

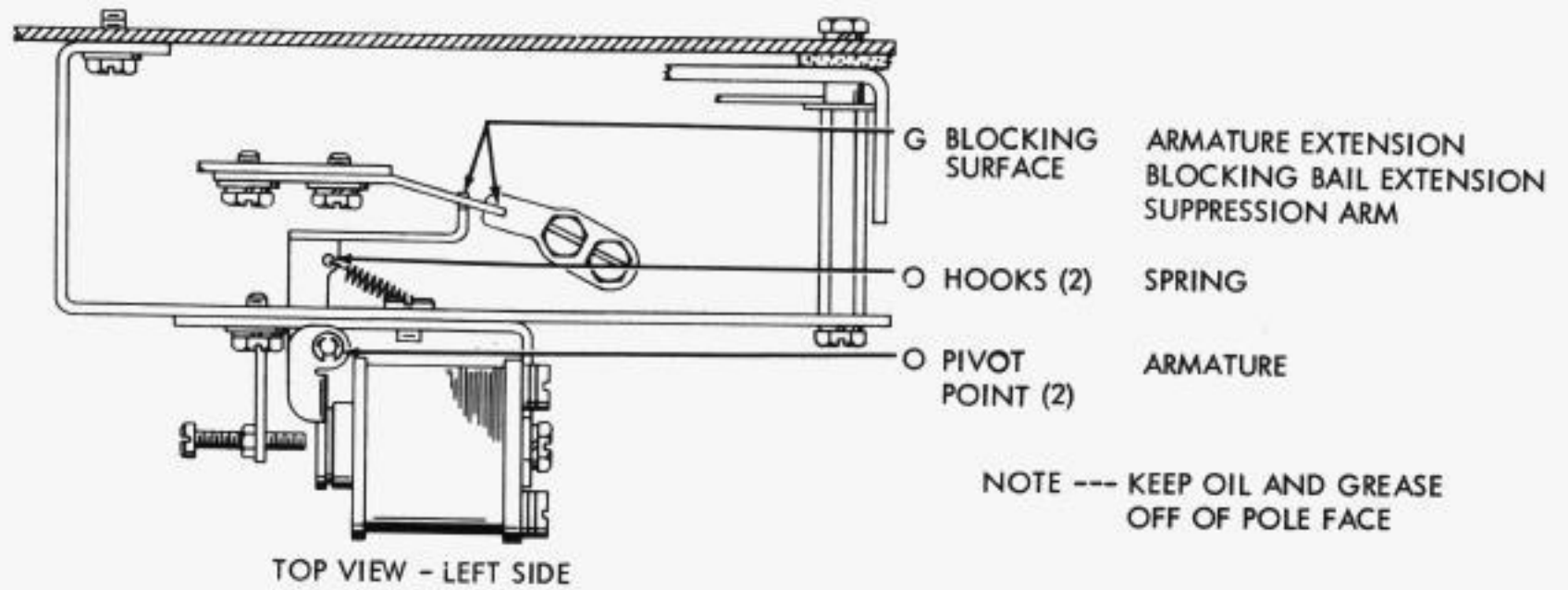

LETTERS- FIGURES CODEBAR SHIFT MAGNET MECHANISM

3.47 Shift Magnet Mechanism

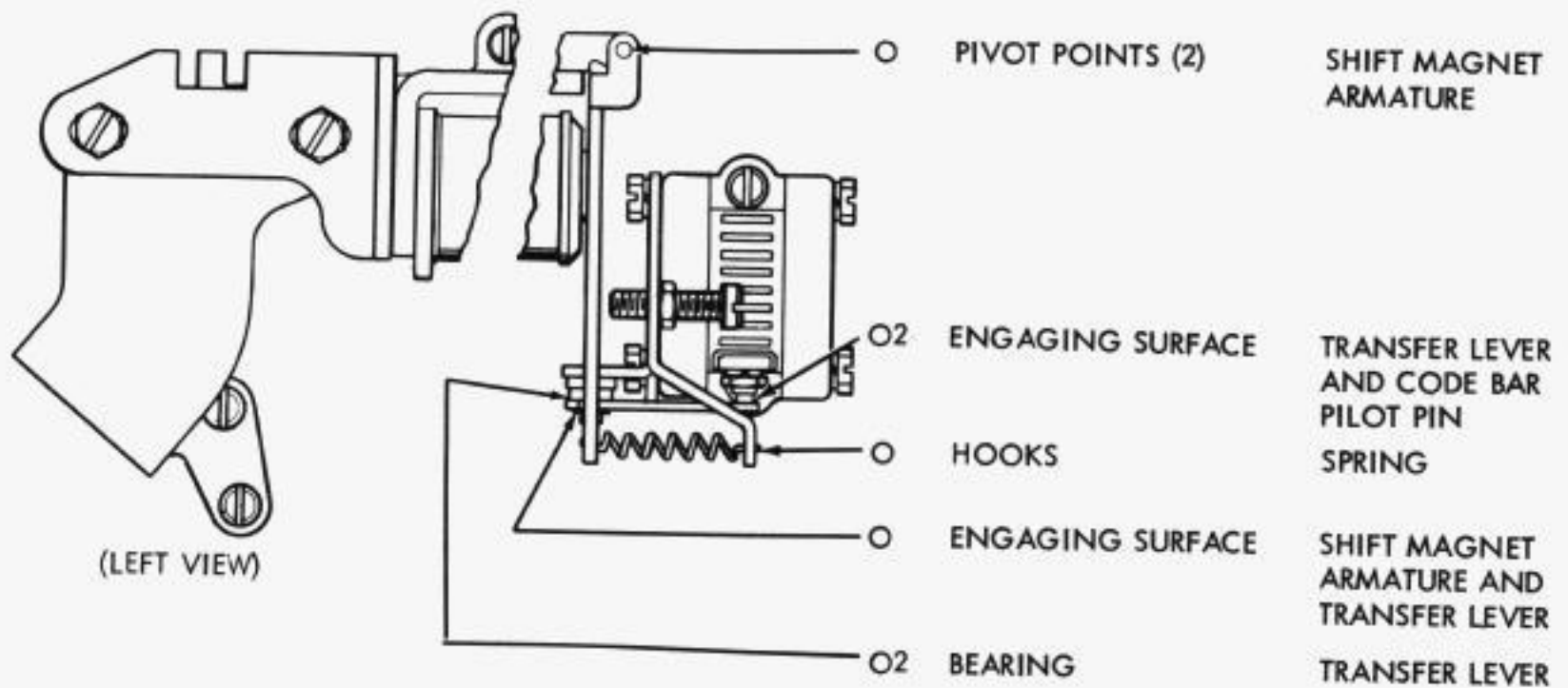

PRINT SUPPRESSION AND OFF-LINE STUNT SHIFT CONTROL MECHANISM

3.48 Shift Mechanism

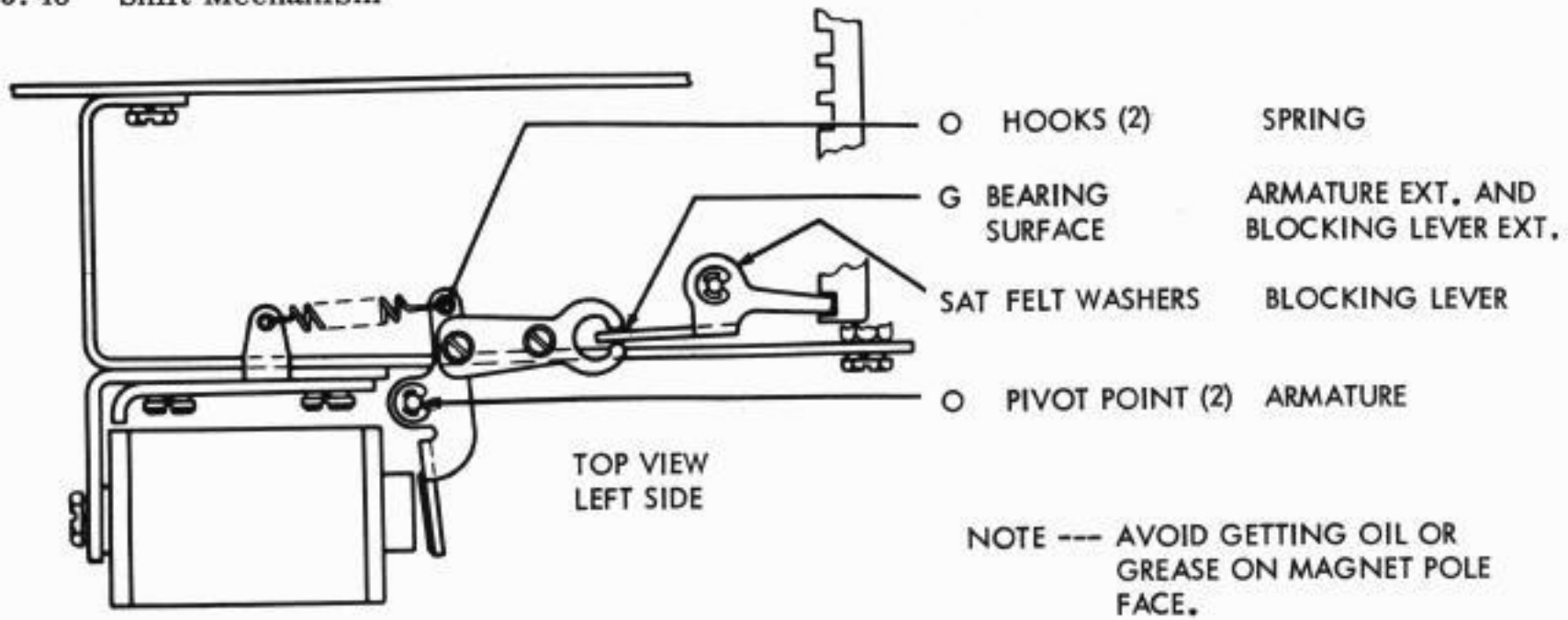

FORM FEED-OUT MECHANISM

3.49 Feed-Out Bail

