

35 "CARDATA"\* READER (LEXD)

ADJUSTMENTS

CONTENTS	PAGE	CONTENTS	PAGE
1. GENERAL . . . . .	2	Clutch Trip Magnet Assembly	
2. BASIC UNITS . . . . .	6	Armature bail spring . . . . .	29
Auxiliary Contacts		Clutch trip magnet assembly —	
Auxiliary contact operating bail		final. . . . .	29
spring . . . . .	50	Clutch trip magnet assembly . . . . .	7
Contact assembly position —		Clutch trip magnet assembly —	
preliminary. . . . .	50	preliminary. . . . .	7
Contact swinger — operating bail		Main bail latch spring. . . . .	29
clearance . . . . .	51	Clutch Trip Mechanism	
Normally closed contacts. . . . .	49	Clutch latchlever spring . . . . .	28
Normally open contacts. . . . .	49	Clutch shoe lever. . . . .	28
Card-In Contact Mechanism		Clutch trip lever . . . . .	28
Card-in contact . . . . .	39	Clutch trip lever spring. . . . .	28
Card-in contact actuating lever		Code Reading Contacts	
spring . . . . .	39	Contact assembly alignment. . . . .	46
Card-Out, Card-In, and Eject Contact		Contact assembly position —	
Mechanism		preliminary. . . . .	47
Card-out, card-in, and eject		Contact sensing arm, up-stop	
contact . . . . .	15	adjustment . . . . .	47
Swinger contact spring . . . . .	15	Contact swinger — sensing arm	
Card-Out Mechanism		clearance . . . . .	48
Card-out contact assembly. . . . .	16	Normally closed contacts —	
Card-out contact . . . . .	38	backstop. . . . .	44
Card-out contact actuating lever		Normally closed contacts — spring. . . . .	44
spring . . . . .	38	Normally open contacts — gap. . . . .	44
Card Stop and Tape Switch Mechanism		Normally open contacts — spring. . . . .	44
Card stop . . . . .	24	Sensing arm spring. . . . .	45
Tape switch. . . . .	24	Sensing arm — transfer lever	
Clutch Mechanism		alignment . . . . .	45
Clutch shoe lever spring . . . . .	6	Split bail eccentric. . . . .	45
Clutch shoe spring . . . . .	6	Code Sensing Fingers	
		Sensing hole alignment . . . . .	23
		Detent Assist Assembly	
		Detent assist assembly . . . . .	31
		Detent assist cam follower	
		spring . . . . .	31
		Detent assist torsion spring. . . . .	31

\*Trademark of Teletype Corporation

CONTENTS	PAGE
Drive Mechanism	
Gear backlash . . . . .	17
Eject Actuator Contact Assembly	
Eject contact actuating lever spring. .	40
Eject contact actuator . . . . .	40
Eject actuator — preliminary . . . . .	16
Eject Solenoid Mechanism	
Eject solenoid stroke . . . . .	35
Ratchet clutch bail spring . . . . .	35
Fan Drive Mechanism	
Gear backlash for fan drive . . . . .	37
Feed Pawl and Transfer Mechanisms	
Feed pawl eccentric — preliminary .	13
Feed pawl spring . . . . .	13
Locking bail spring. . . . .	13
Transfer lever spring. . . . .	13
Feedwheel Mechanism	
Feed pawl — final . . . . .	30
Feedwheel phasing — final . . . . .	25
Feedwheel phasing — preliminary . .	19
Idler Feedwheel and Tape Guide Mechanisms	
Idler feedwheel bracket. . . . .	14
Tape guides. . . . .	14
Lid Solenoid Mechanism	
Lid solenoid stroke. . . . .	34
Solenoid mounting bracket . . . . .	33
Main Bail Assembly	
Feed ratchet detent spring. . . . .	11
Feedwheel detent eccentric — preliminary. . . . .	11
Main bail . . . . .	27
Main bail drive arm — preliminary. . . . .	11
Main bail latchlever . . . . .	26
Main bail spring. . . . .	27
Sensing finger spring . . . . .	27
Motor Gear Plate Assembly	
Motor gear backlash. . . . .	36
Pulley Mechanisms	
Belt tension. . . . .	36
Eject drive belt . . . . .	36

CONTENTS	PAGE
Ratchet Clutch Mechanism	
Ratchet clutch endplay. . . . .	32
Ratchet clutch spring . . . . .	32
Signal Contact Assembly	
Signal contact . . . . .	41
Signal contact spring. . . . .	41
Signal contact drive link spring. . . . .	41
Signal pulse refinement — final adjustment with DXD or strobe. . . . .	42,43
Timing Contact Mechanism	
Cam follower spring. . . . .	9
Timing contact alignment. . . . .	9
Timing contact bracket — preliminary. . . . .	10
Timing contact gap. . . . .	9
Timing contact requirement. . . . .	52,53
Timing contact spring. . . . .	10
Top Plate Assembly	
Forward guide. . . . .	22
Guide plate — preliminary . . . . .	12
Lid card guide. . . . .	22
Lid positioning. . . . .	21
Lid spring. . . . .	21
Main guides. . . . .	18
Top plate — horizontal. . . . .	20
Top plate — vertical . . . . .	20
Transfer Bail Stabilizer	
Stabilizer spring . . . . .	8
Transfer bail stabilizer. . . . .	8

## 1. GENERAL

1.01 This section contains the specific requirements and adjustments for the 35 "CARDATA" reader (edge punched card reader) (Figure 1).

**CAUTION: REMOVE POWER FROM SET OR UNIT BEFORE MAKING ADJUSTMENTS.**

1.02 The adjustments in this section are arranged in a sequence that should be followed if a complete readjustment of the unit is undertaken. A complete adjusting procedure should be read before attempting to make the adjustment. After an adjustment is completed, be sure to tighten any nuts or screws that may have been loosened, unless otherwise instructed.

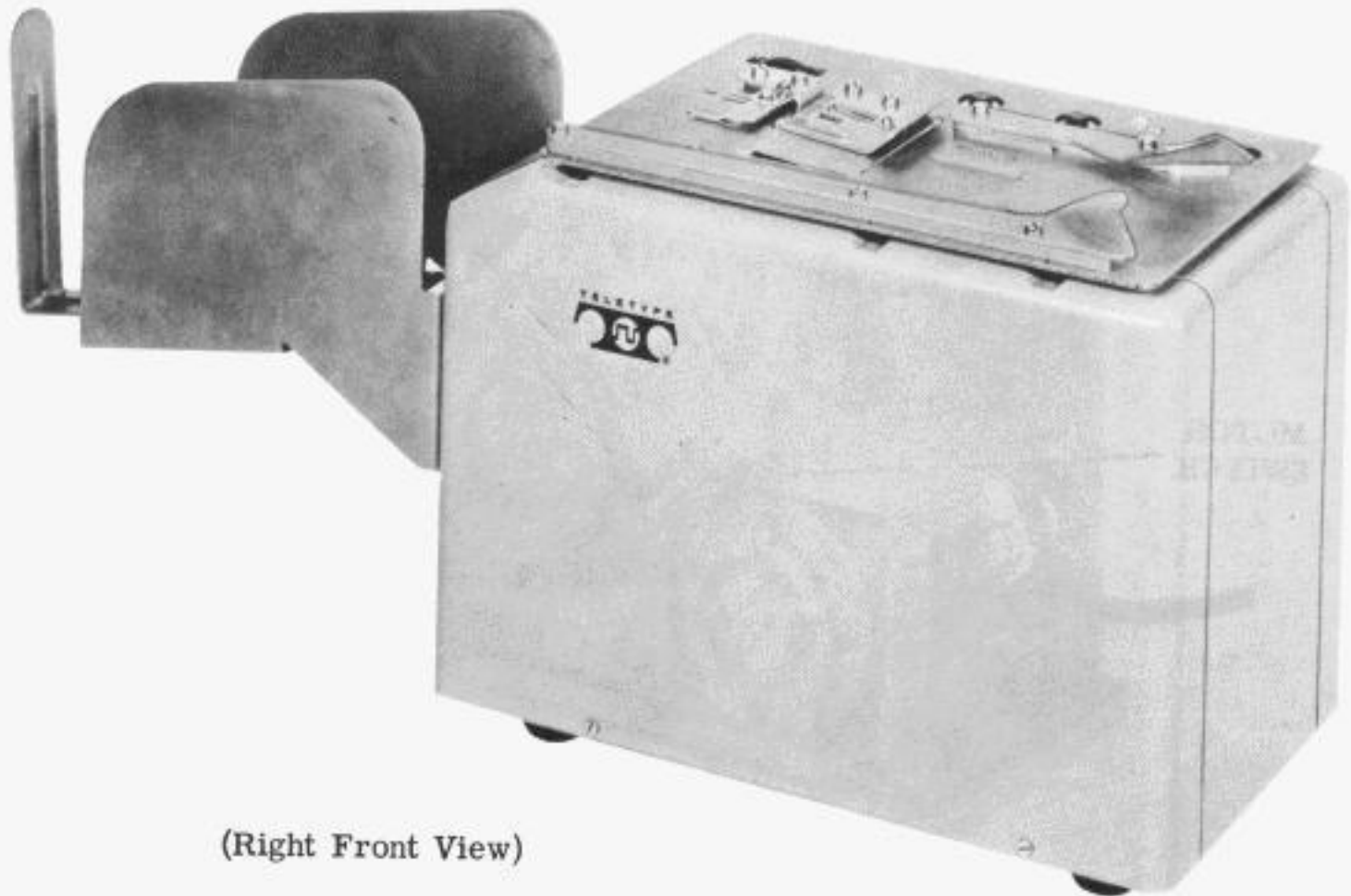

(Right Front View)

Figure 1 - 35 Edge Punched Card Reader

1.03 The adjusting illustrations indicate tolerances, positions of moving parts, spring tensions, and the angle at which scales should be applied. The tools required to make adjustments and check spring tensions are not supplied with the equipment, but are listed in the appropriate tool section (570-005-800). Springs which do not meet the requirements, and for which there are no adjusting procedures, should be discarded and replaced by new springs.

1.04 References made to left or right, up or down, front or rear, etc, apply to the unit in its normal operating position as viewed from the front.

1.05 If necessary, refer to the appropriate disassembly and reassembly section for removal of cover, top plate assembly, and any internal mechanisms associated with the reader. For any further information regarding location of parts, refer to exploded views in the appropriate parts section.

1.06 When a requirement calls for a clutch to be disengaged, the clutch shoe lever must be fully latched between its trip lever and latch-lever so that the clutch shoes release their tension on the clutch drum. When engaged, the clutch shoe lever is unlatched and the clutch shoes are wedged firmly against the clutch drum.

Note: When the main shaft is rotated by hand, the clutch does not fully disengage upon reaching its stop position. In order to relieve drag and permit the main shaft to rotate freely, apply pressure on the lug of the clutch disc with a screwdriver to cause it to engage its latchlever and fully disengage the clutch.

1.07 Where adjustment instructions call for removal of components, assemblies, subassemblies or parts, all adjustments which the removal of these parts might facilitate should be made before the parts are replaced or as the equipment is reassembled. When a part mounted on shims is removed, the number of shims and their location should be noted so that the identical pile-up can be made when the part is replaced.

1.08 All electrical contact points should meet squarely. Contacts with the same diameter should not be out of alignment more than 25 percent of the contact diameter. Check contacts for pitting and corrosion and clean or bur-nish them before making specified adjustment or tolerance measurement. Avoid sharp kinks or bends in the contact springs.

**CAUTION: KEEP ALL ELECTRICAL CON-TACTS FREE OF OIL AND GREASE.**



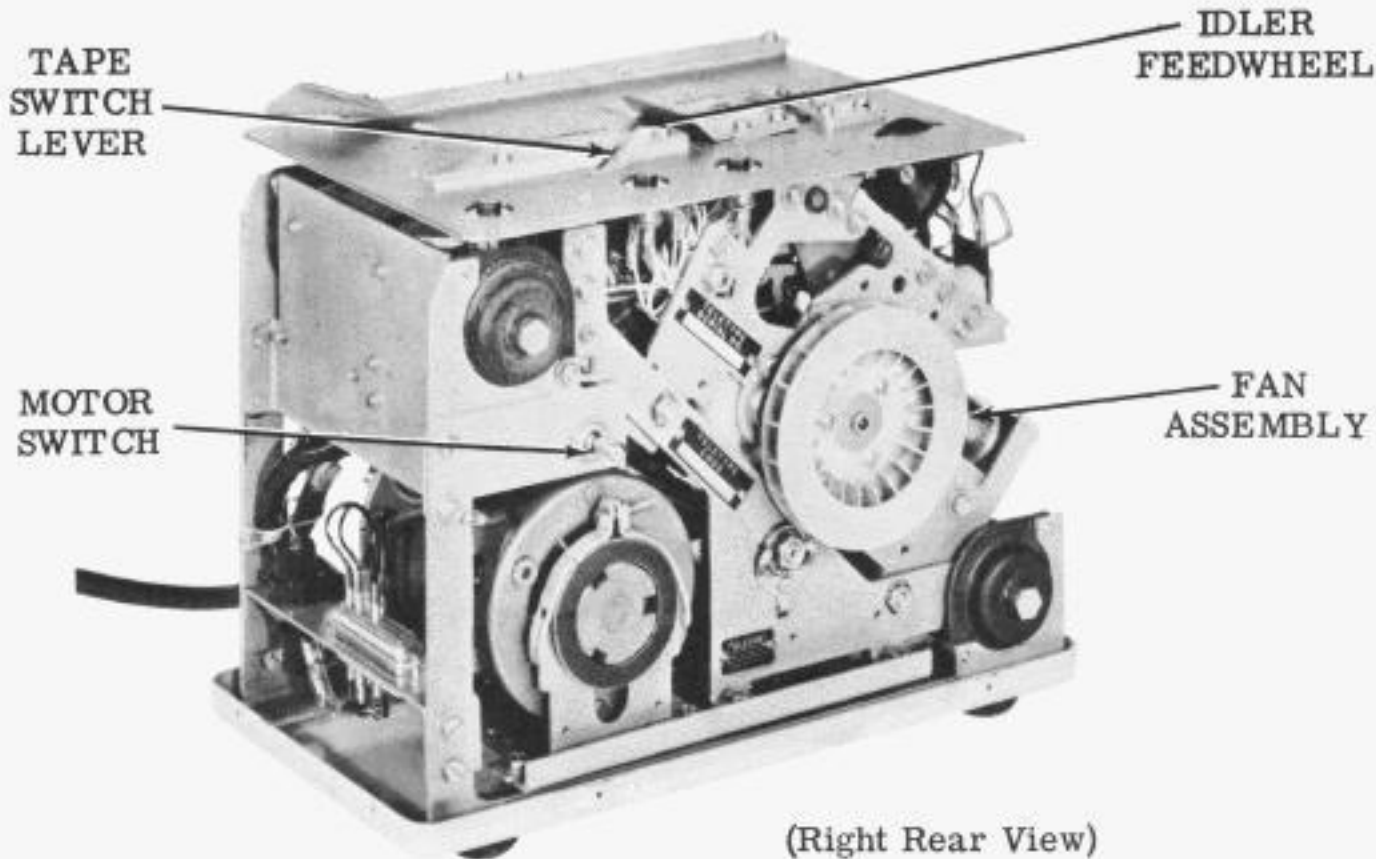

Figure 2 - 35 Edge Punched Card Reader Without Cover

1.09 Units may have signal contacts made of either unplated or gold-plated tungsten. If in doubt as to the type of contacts, remove signal generator cover and inspect contacts for gold plating.

**CAUTION: DO NOT USE BURNISHERS, FILES, ETC WHICH WILL REMOVE GOLD PLATING.**

1.10 Use twill jean cloth (KS2423) (TP107162) to clean gold-plated contacts. Open contacts. Draw twill jean part way through. Open contacts and withdraw twill jean.

1.11 This procedure prevents small fibers at edges of twill jean strip from becoming lodged between contacts.

1.12 Clean unplated tungsten contacts in accordance with standard procedures. (See Paragraph 1.08.)

#### Servicing for Low-Voltage Applications

1.13 For standard applications including those with data sets, observe standard maintenance procedures and intervals. Low voltage applications are covered below.

1.14 For optimum reliable operation in low-voltage applications, clean gold-plated contacts with twill jean, as instructed above, at intervals of approximately 50 hours of actual contact operation. Since maintenance interval and life expectancy of the contacts are dependent on the signal circuit, maintenance interval may be lengthened for specific applications.

Note 1: Applying operating voltage of standard Distortion Test Set directly to contacts may damage gold plating and impair low-voltage operation. When electrically adjusting or testing contacts (Par. 2.39 and 2.40); use an intermediate device, keyed by the contacts, to interrupt current to stroboscopic lamp of Test Set. This intermediate device must be capable of being keyed by a 3 to 20 volt change at maximum of 20 milliamperes.

Note 2: Normally for low-voltage applications, contacts should be used in circuits operating between 3 and 20 volts dc at a current level not to exceed 60 milliamperes. Between 20 and 70 volts dc the current should be adjusted so as not to exceed a 120 milliwatt power level. The contacts are not normally intended for use with voltages above 70 volts dc. Exceeding this level for an appreciable length of time may result in damage to the gold plating and make them unfit for low-voltage applications.

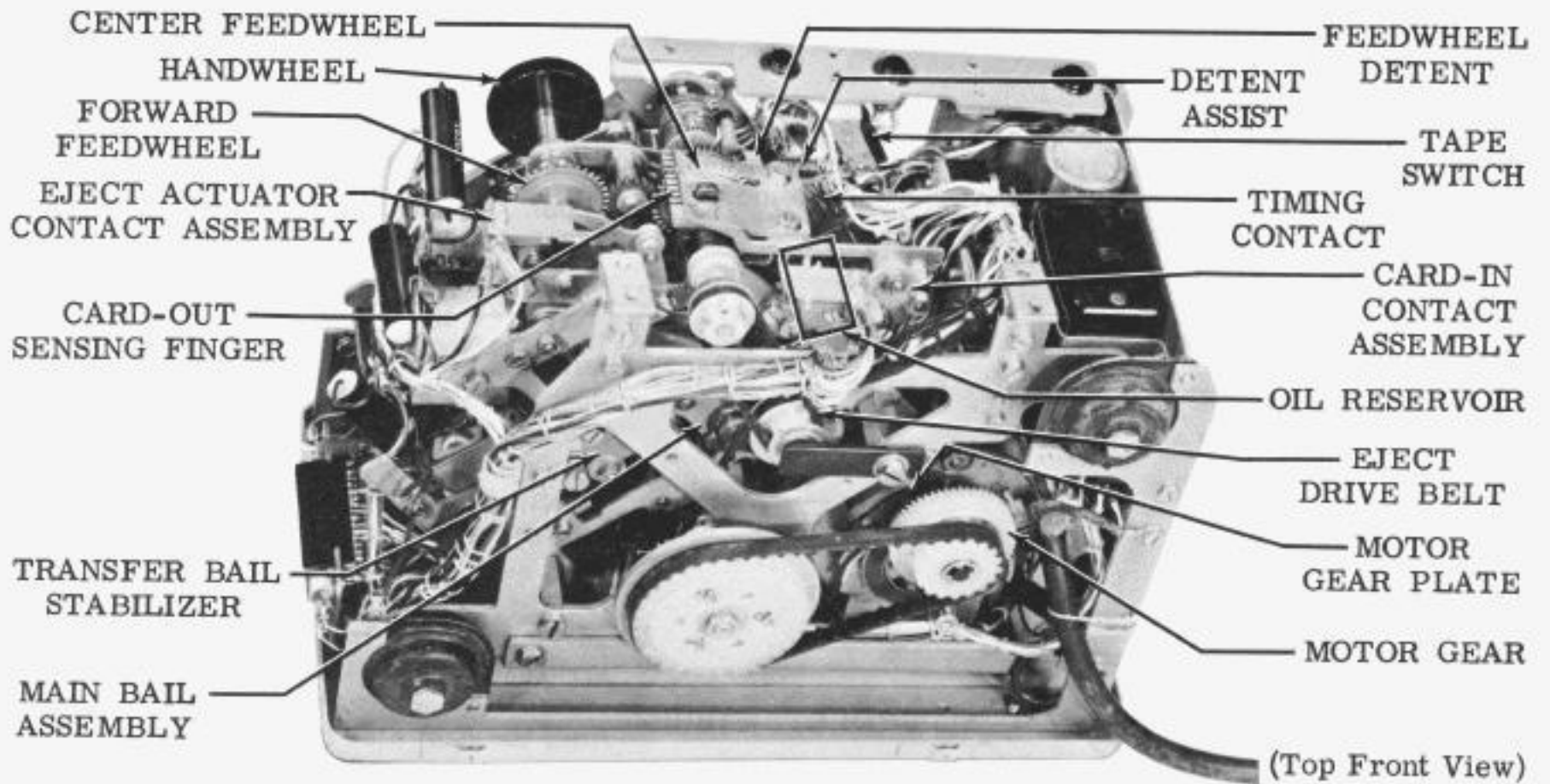

Figure 3 - 35 Edge Punched Card Reader Without Cover and Top Plate

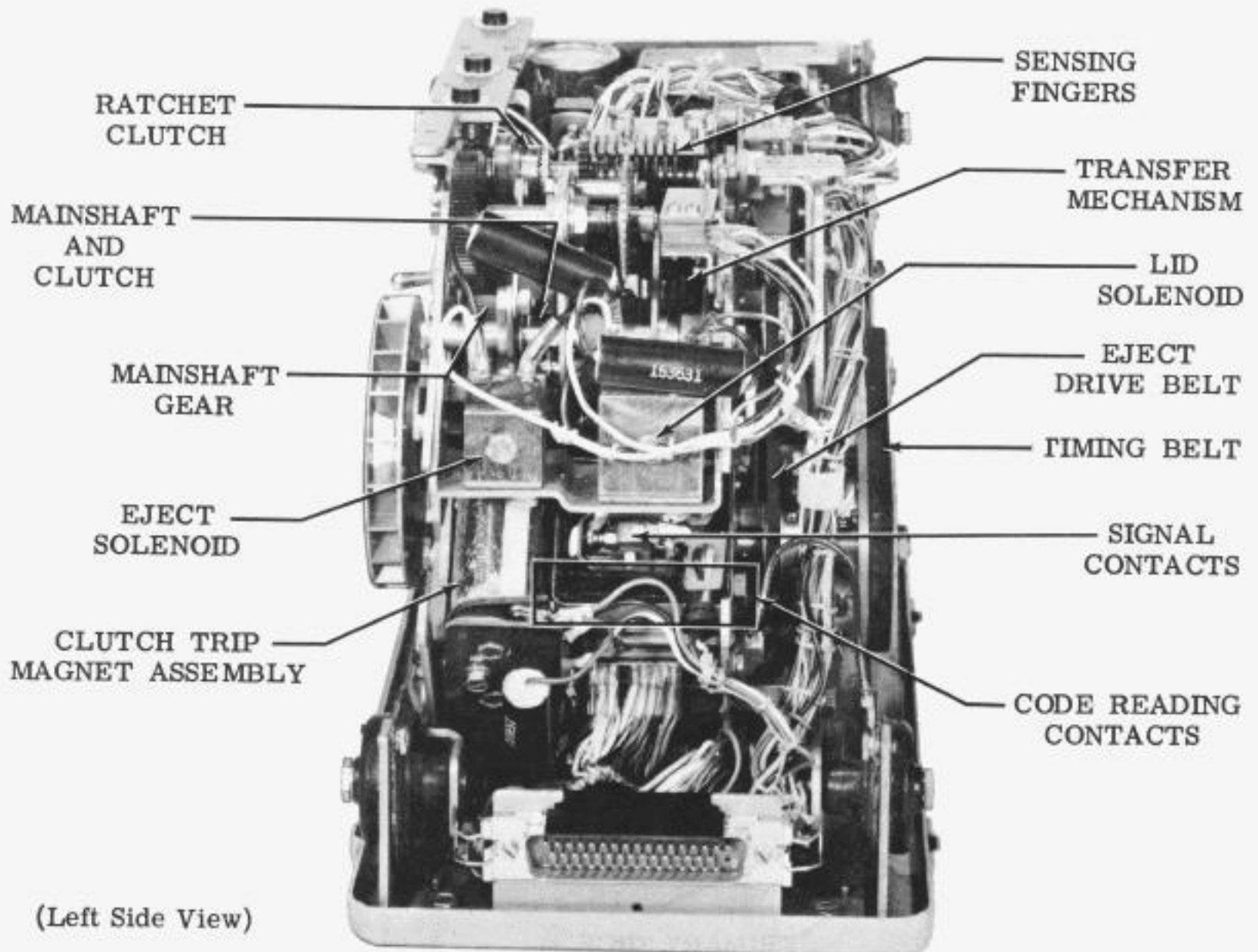

Figure 4 - 35 Edge Punched Card Reader Without Cover and Top Plate

2. BASIC UNITS

2.01 Clutch Mechanism

Note: Requirements (A) and (B) are adjusted at the factory and should not be disturbed unless associated mechanisms have been removed for servicing or there is reason to believe that the requirements are not met.

(A) CLUTCH SHOE LEVER SPRING

Requirement

With clutch engaged, hold cam disc to prevent turning. Spring scale pulled at tangent to clutch.

Min 15 oz---Max 20 oz  
to move shoe lever in contact with stop lug.

To Measure

Invert unit. Rotate main shaft until clutch shoe lever and stop lug are up. Hold the cam disc and gear to prevent turning.

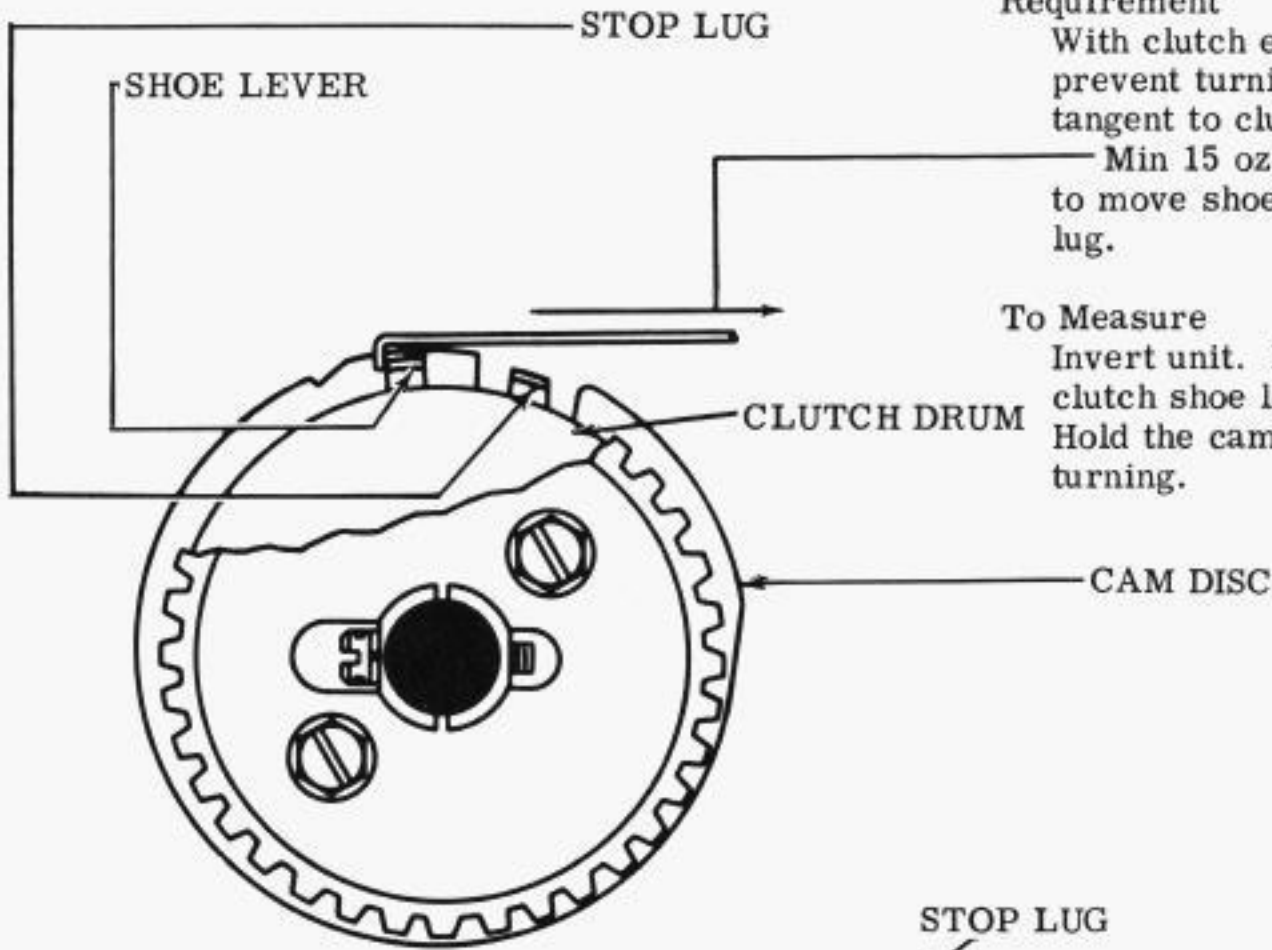

(B) CLUTCH SHOE SPRING

Requirement

With clutch drum removed, hook spring scale as shown.

Min 3 oz---Max 5 oz  
to start primary shoe moving away from secondary shoe at point of contact.

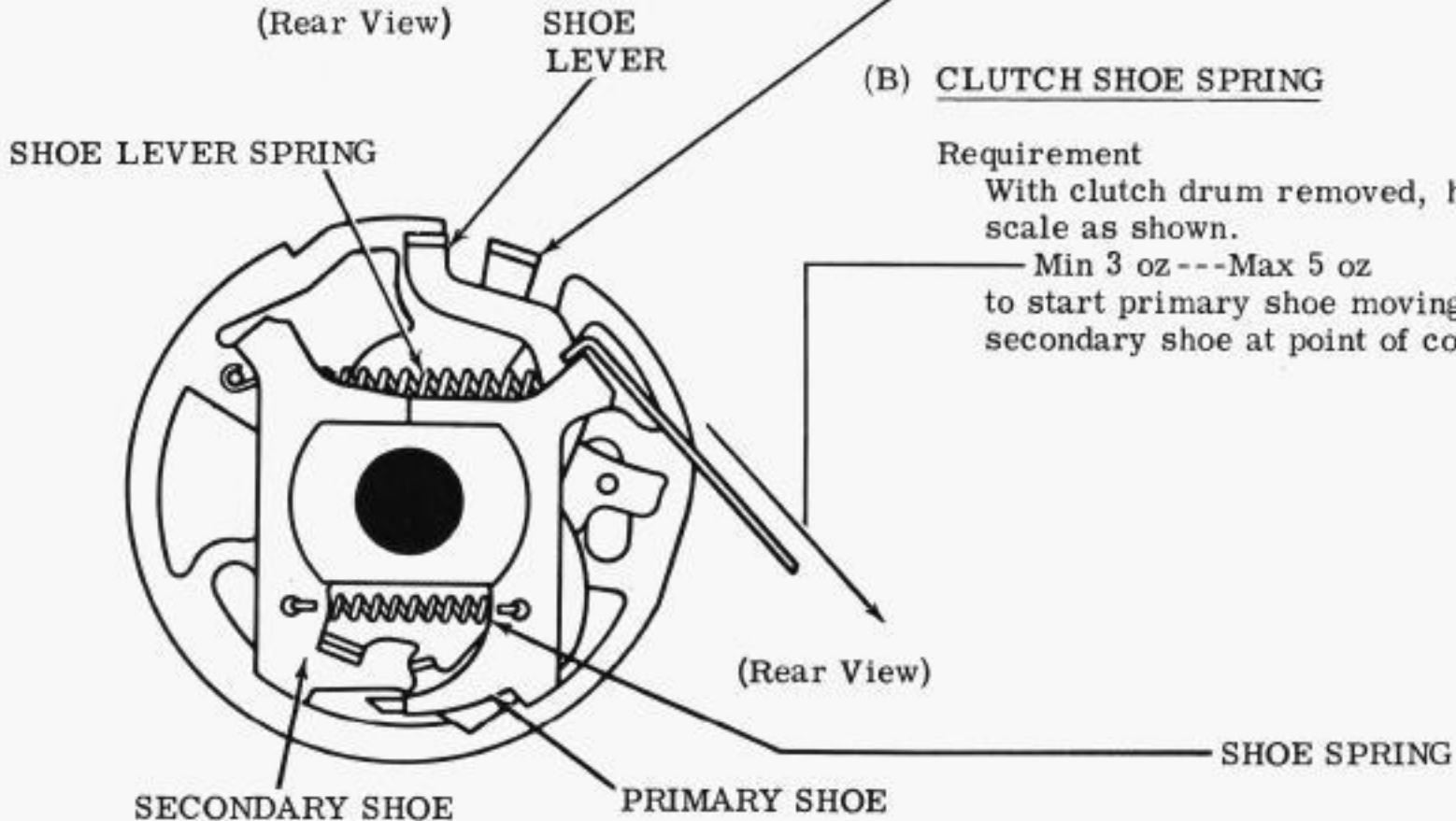



2.02 Clutch Trip Magnet Assembly

(A) CLUTCH TRIP MAGNET ASSEMBLY

Note: Requirements (1) and (2) are adjusted at the factory and should not be disturbed unless associated mechanisms have been removed for servicing or there is reason to believe that the requirements are not met. These adjustments are made with the assembly removed from the unit. See the appropriate disassembly and reassembly section covering the clutch trip magnet assembly.

(1) Requirement

With armature in its energized position, the armature should contact the core of the magnet farthest away from the armature hinge. Clearance between armature and core nearest armature hinge  
 Min Some---Max 0.004 inch  
 at point of least clearance when the play is taken up to make the clearance a maximum.

To Adjust

With magnet bracket mounting screws removed, lift magnet assembly from unit. Invert assembly, loosen hinge bracket mounting screws and position bracket. Tighten hinge bracket mounting screws and replace assembly.

(2) Requirement

With armature in its energized position and high part of backstop eccentric upward, clearance between armature bail and backstop  
 Min 0.045 inch---Max 0.055 inch

To Adjust

Loosen backstop clamp nut and position the eccentric. Tighten nut.

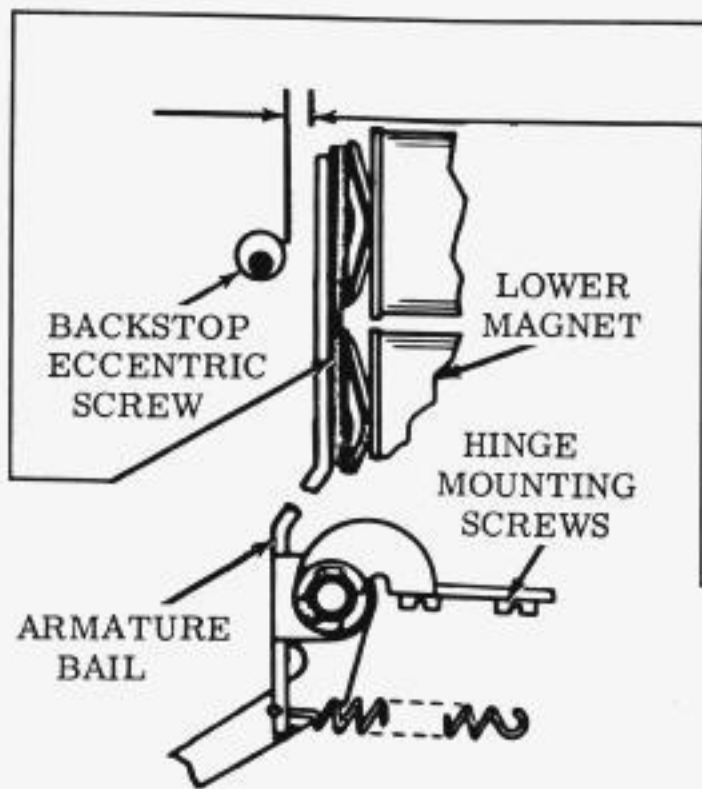

(Rear View)

(B) CLUTCH TRIP MAGNET ASSEMBLY — PRELIMINARY

Note: Remove fan assembly.

Requirement

With bracket mounting screws friction tight and the armature held in the energized position, move the magnet assembly upward until the armature bail extension just trips the main bail latchlever. Tighten mounting screws but do not replace the fan assembly at this time.

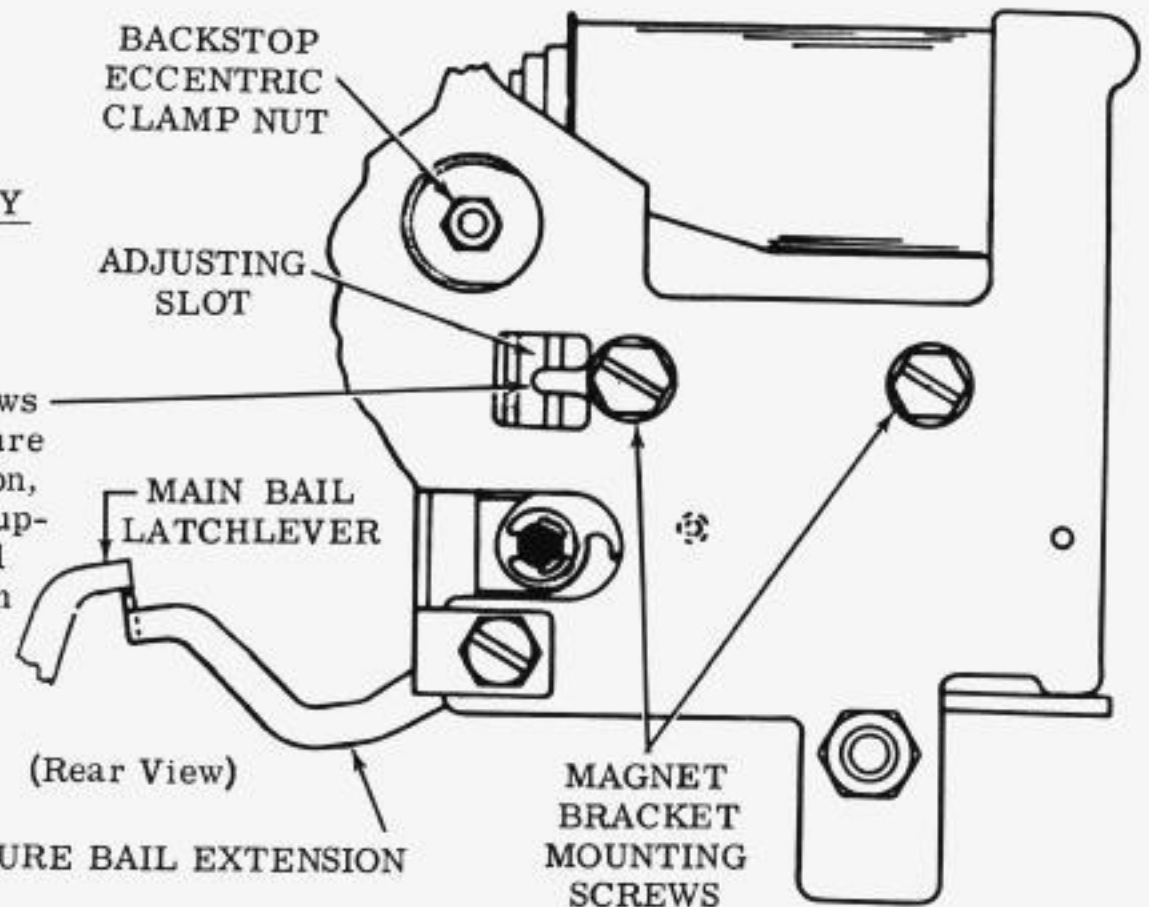

(Rear View)

2.03 Transfer Bail Stabilizer

(A) TRANSFER BAIL STABILIZER

(1) Requirement

With the RUBOUT combination selected, rotate mainshaft until no. 3 transfer lever is on high part of its cam. Check and note the maximum clearance between side of transfer bail extension and its latch.

(2) Requirement

Repeat above procedure with the SPACE combination selected and check the maximum clearance on the other latch. Clearance in MARKING and SPACING position should be equal within 0.002 inch.

To Adjust

Remove the intermediate eject drive pulley. With stabilizer assembly mounting screws friction tight, position the assembly. Tighten the mounting screws and recheck the adjustment.

Note: Latches should drop in place as other transfer levers cam the transfer bail. Where possible, use a signal checking device to refine this adjustment following SIGNAL PULSE REFINEMENT — FINAL

Related Adjustment:

GEAR BACKLASH FOR FAN DRIVE

(B) STABILIZER SPRING

Requirement

With unit upright and mainshaft in stop position  
 Min 2-1/2 oz --- Max 5 oz  
 to start stabilizer latch moving.

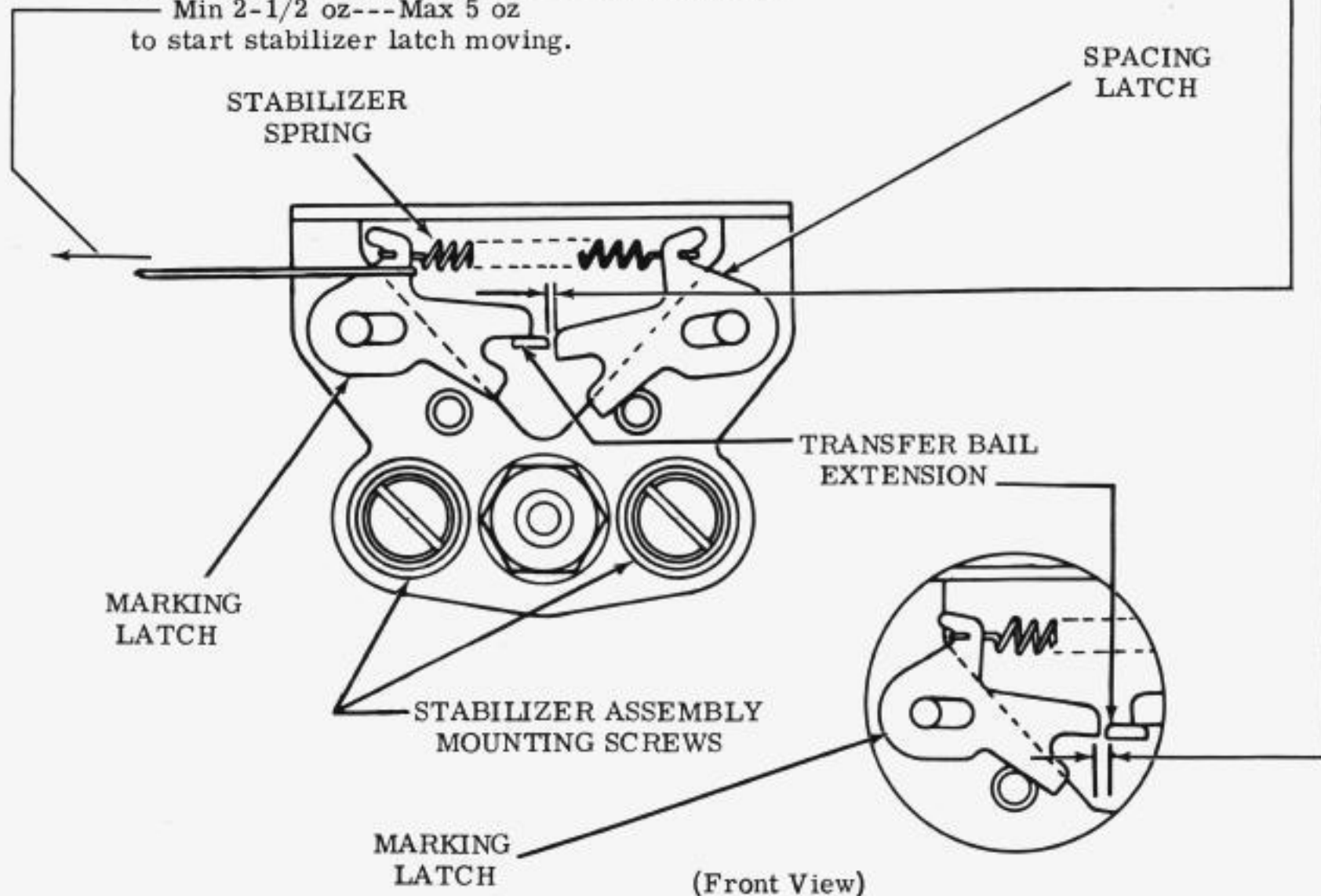



2.04 Timing Contact Mechanism

Note: The timing contact assembly must be removed to check the following requirements.

(A) CAM FOLLOWER SPRING

**Requirement**

With the unit upright and in the stop position, it should require  
Min 2 oz---Max 4 oz  
to start the cam follower moving.

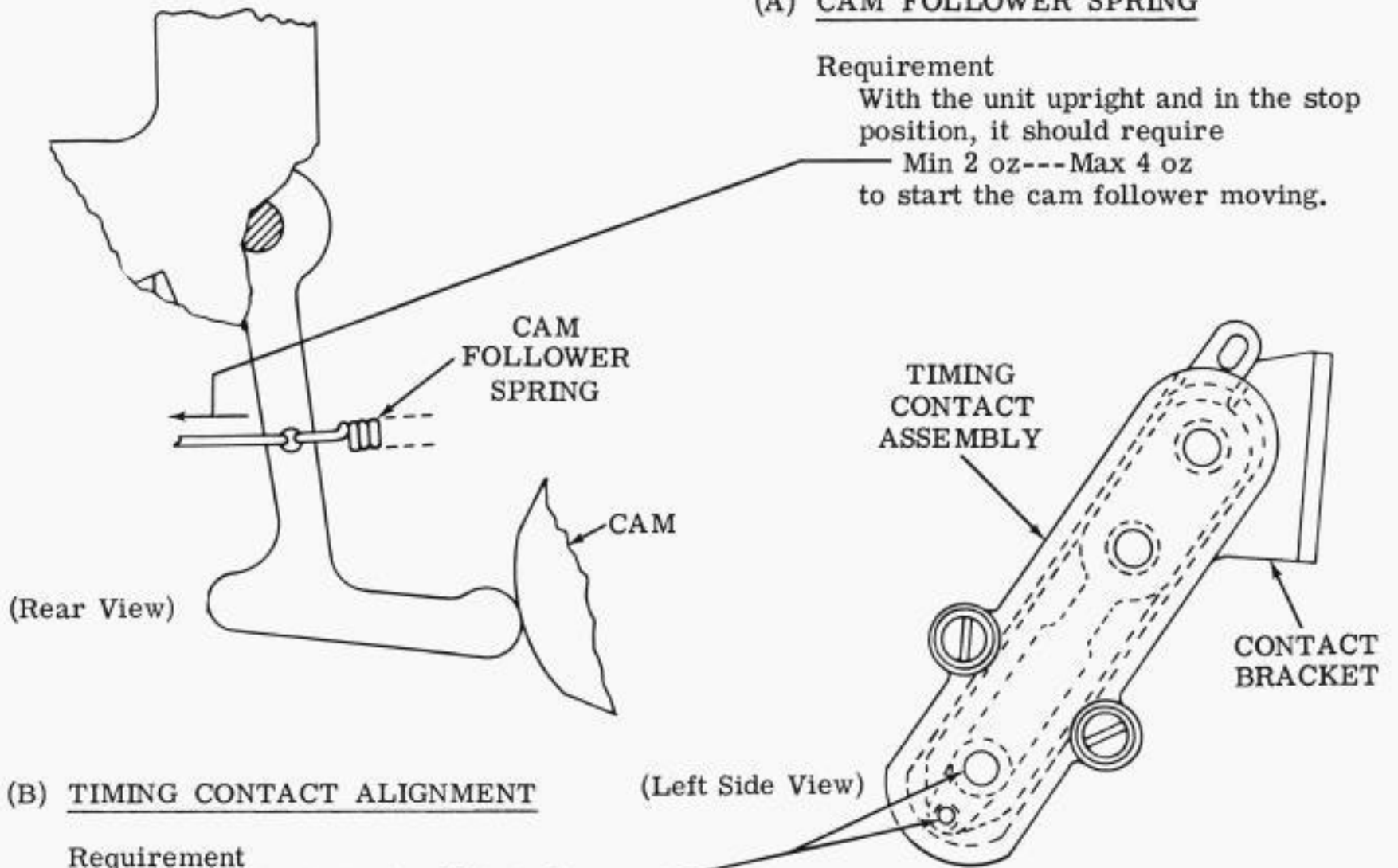

(B) TIMING CONTACT ALIGNMENT

**Requirement**

The contact points should be in line and the head of the plunger should be centered in the hole in the lower contact spring as gauged by eye.

**To Adjust**

With the contact assembly mounting screws friction tight, position the contact springs. Tighten screws firmly.

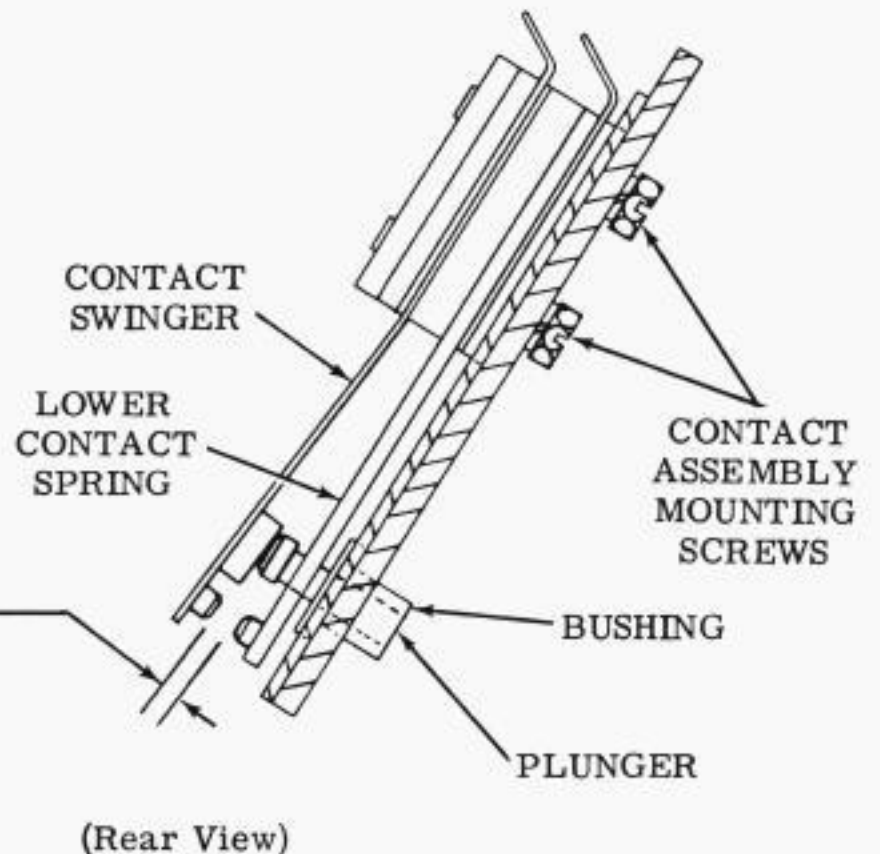

(C) TIMING CONTACT GAP

**Requirement**

With the plunger depressed flush with the bushing, the contact gap should be  
Min 0.045---Max 0.065 inch.

**To Adjust**

Bend the lower contact spring.

2.05 Timing Contact Mechanism (continued)

TIMING CONTACT SPRING

Requirement

Min 3-1/2 oz---Max 4-1/2 oz  
to open the normally closed contacts.

To Adjust

Bend the contact swinger.

Note: Replace the timing contact assembly at this time.

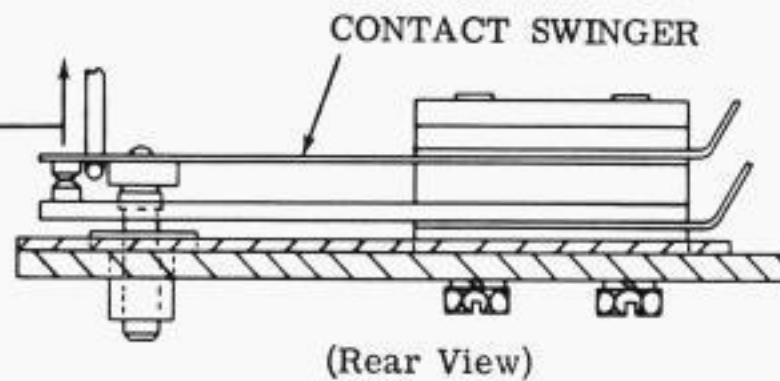

TIMING CONTACT BRACKET — PRELIMINARY

(1) Requirement

With the unit in the stop position,  
Min 0.008---Max 0.011 inch  
gap between the contacts

(2) Requirement

With cam follower on each low  
part of cam and clearance taken  
up between plunger and cam  
follower.

Min Some---clearance between  
plunger and contact swinger

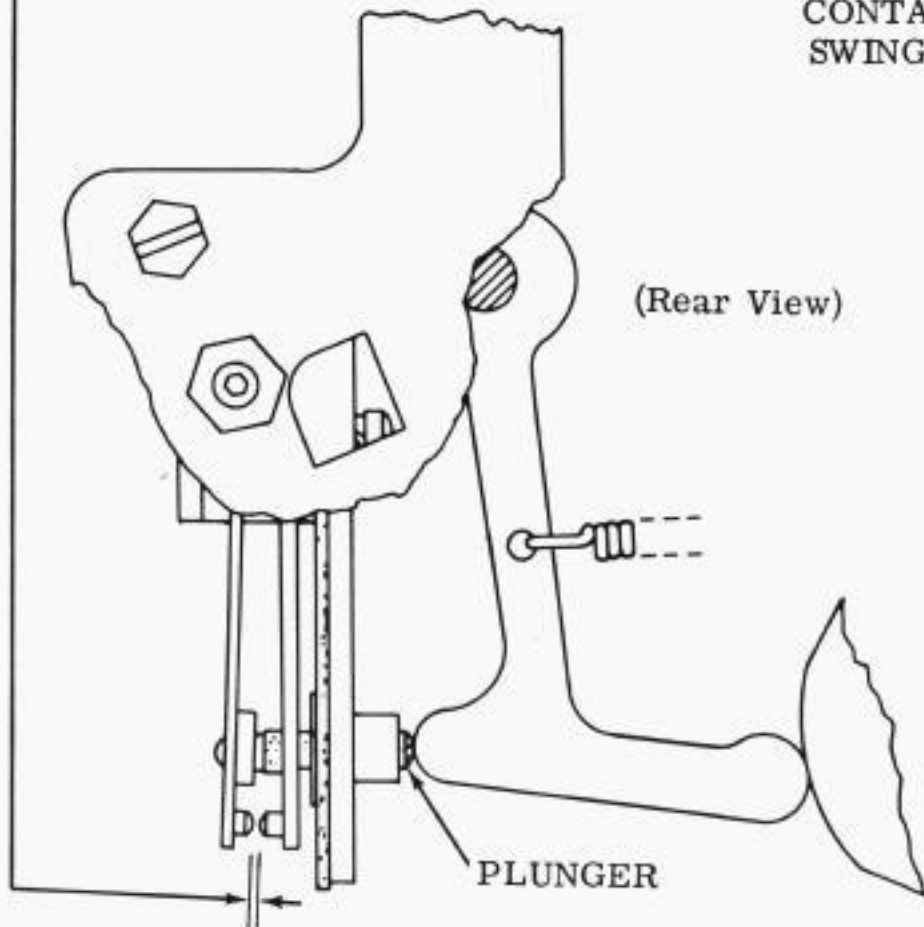
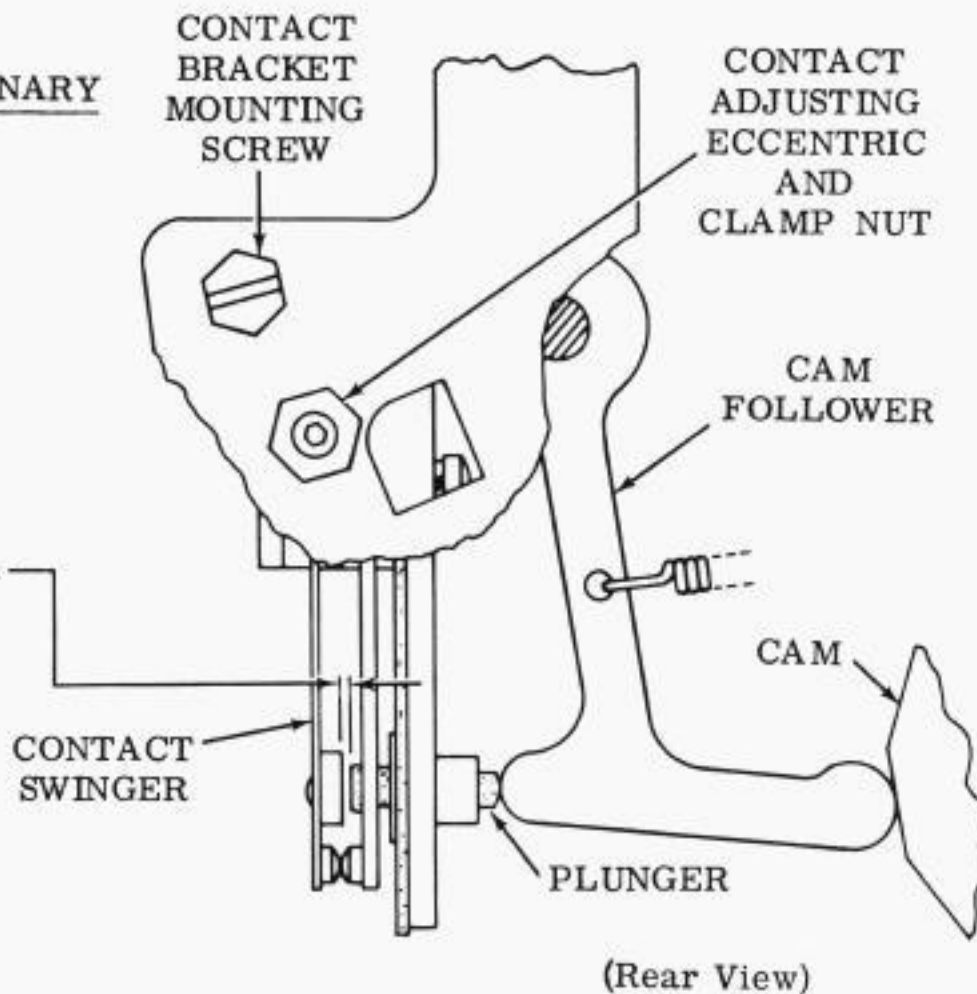

To Adjust

With unit in the indicated position and the timing contact bracket mounting screw and contact adjusting clamp nut friction tight, position the contact assembly by means of the eccentric to meet requirements (1) and (2). Tighten the mounting screw and eccentric clamp nut and recheck the adjustments.

Related Adjustment:

TIMING CONTACT REQUIREMENT

2.06 Main Bail Assembly

Note: Remove the top plate assembly for the following adjustments.

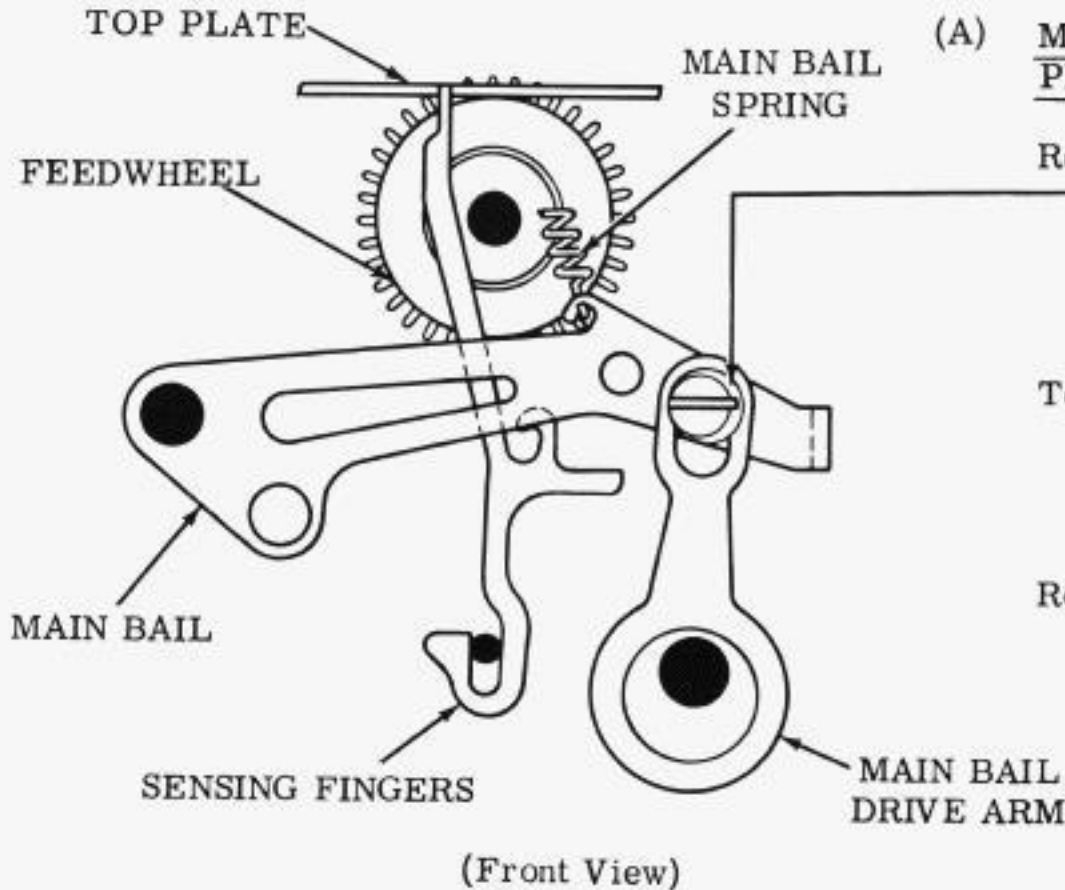

(A) MAIN BAIL DRIVE ARM — PRELIMINARY

Requirement

The high part of the main bail drive arm eccentric (mark or chamfer) should be set to the three o'clock position.

To Adjust

With the nut on the eccentric friction tight, rotate the eccentric. Do not tighten nut at this time.

Related Adjustments:

FEED PAWL — FINAL  
MAIN BAIL

(C) FEED RATCHET DETENT SPRING

Requirement

With the reader in the stop position and the feed pawl held away from the ratchet, apply push end of the scale to the detent roller stud and push horizontally to the left.

Min 8 oz---Max 13 oz  
to start the detent roller moving away from the ratchet.

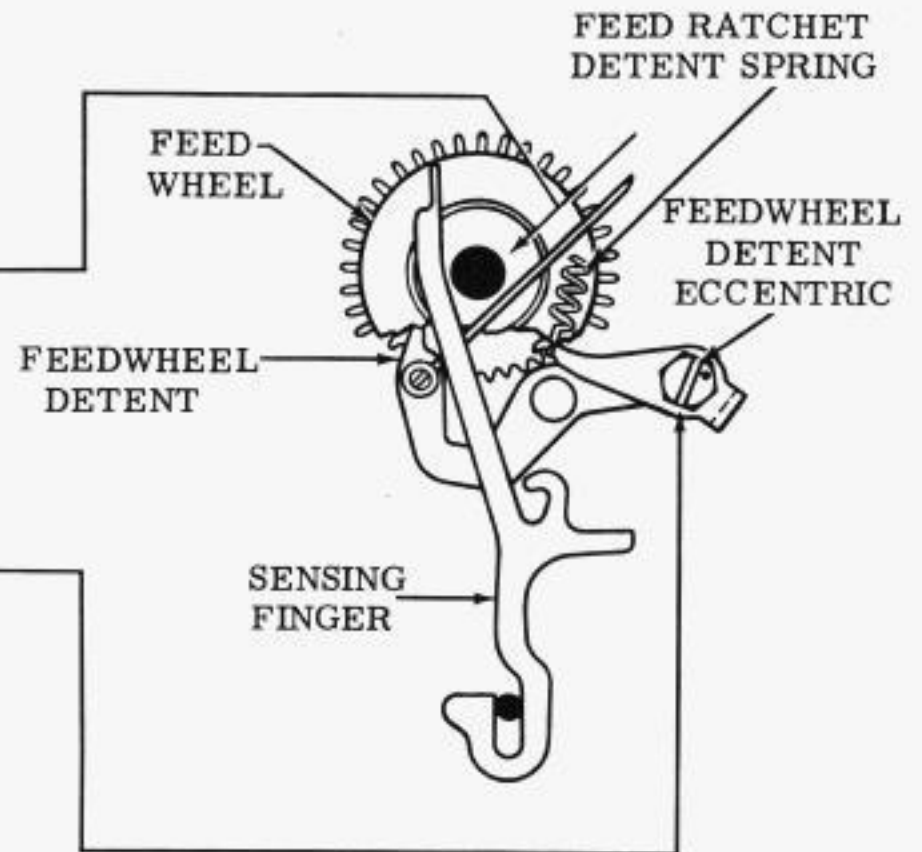

(B) FEEDWHEEL DETENT ECCENTRIC — PRELIMINARY

Requirement

The high part (mark or chamfer) of the detent eccentric should be set to the one o'clock position. Move the eccentric slightly, if necessary, so one feed pin of the feedwheel is vertical as gauged by eye.

To Adjust

With the stud friction tight, rotate the detent eccentric to the required position. Do not tighten the stud at this time.

Related Adjustment:  
FEED PAWL — FINAL

(Front View)



## 2.07 Top Plate Assembly

GUIDE PLATE — PRELIMINARY

## (1) Requirement

The top flat surface of the guide plate, should be approximately in a horizontal position. The top surface should be

Min 0.145 inch---Max 0.161 inch below the top of the most vertical tooth in the feedwheel.

## (2) Requirement

The forward adjusted position of the guide plate should place the centerlines of the top ends of the sensing fingers approximately 0.400 inch ahead of the centerline of the most vertical tooth of the feedwheel. A line through the ends of the sensing fingers should be approximately perpendicular to the direction of feed.

## (1) To Adjust

With the mounting screws that hold the guide plate bracket to the front plate friction tight, with the TP324519 gauge positioned as shown, pivot the bracket so that the top of the most vertical tooth of the feedwheel shall fall within the GO - NO GO notch on the gauge.

## (2) To Adjust

With the guide plate mounting screws friction tight, place the gauge onto the feedwheel. With the left edge of the gauge against the rear surfaces of the sensing fingers, proceed as follows: Move the guide plate on its elongated holes while maintaining light contact between the gauge and the rear of the sensing fingers. Align the sharp corners of the cutout in the gauge with the centerline of the most vertical tooth on the feedwheel. Pivot the guide plate about its mounting screws so that all sensing fingers are in contact with the left edge of the gauge. Retighten the mounting screws.

Note 1: If the SENSING HOLE ALIGNMENT adjustment cannot be met it will be necessary to refine this adjustment.

Note 2: In the event that the adjustment gauge is not available the above adjustments may be made with the aid of a machinists scale.

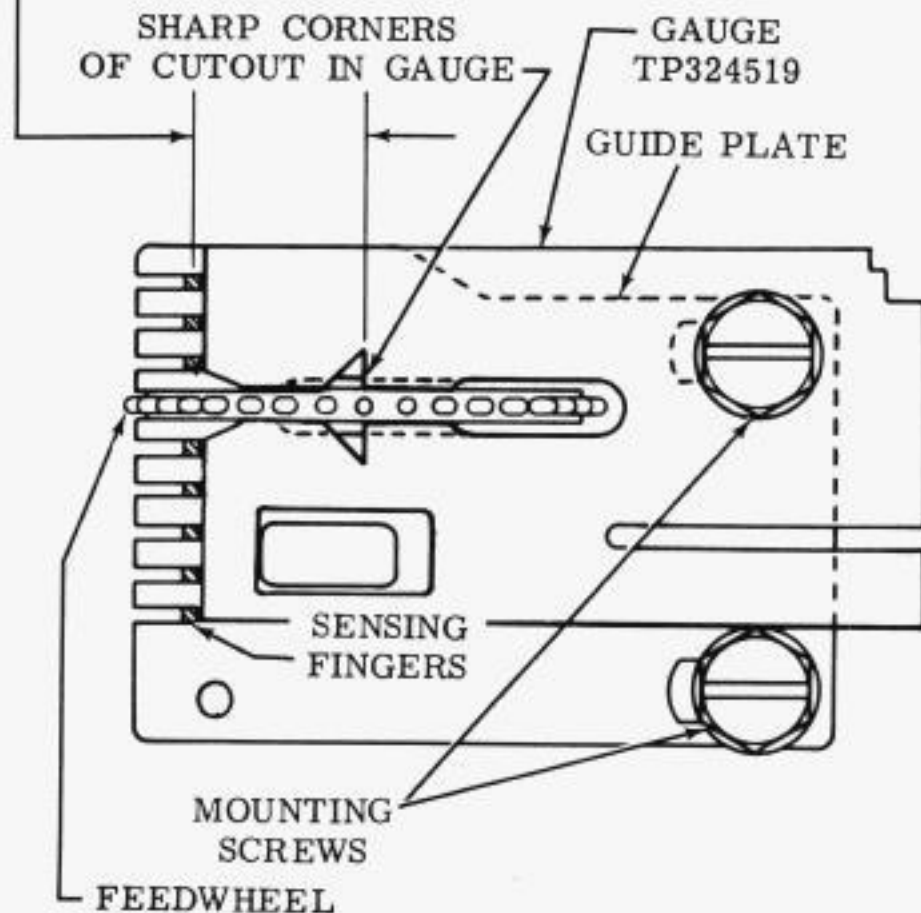
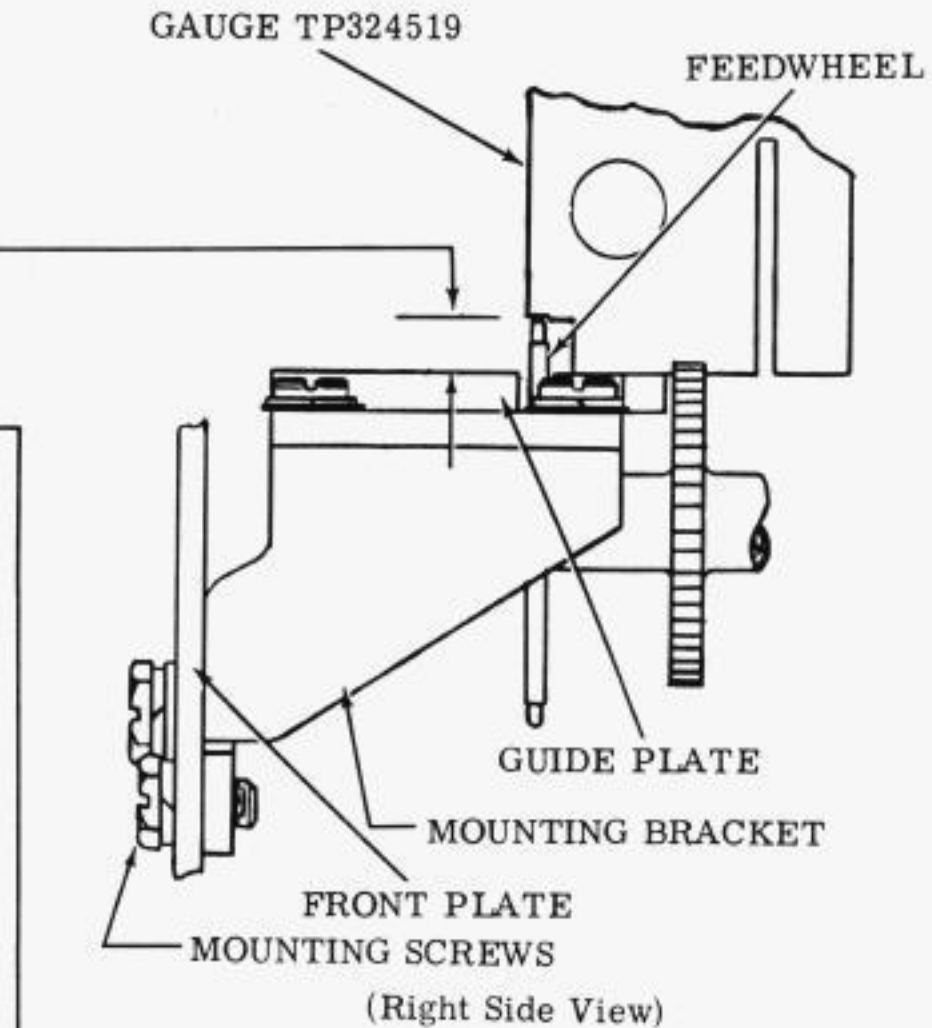

2.08 Feed Pawl and Transfer Mechanisms

(A) FEED PAWL ECCENTRIC — PRELIMINARY

PRELIMINARY FIVE O'CLOCK, MARK OR CHAMFER AS VIEWED FROM SLOT END OF ECCENTRIC

**Requirement**

With the locknut friction tight, set eccentric high point (mark or chamfer) to the five o'clock position as viewed from slot end of the eccentric. Do not tighten locknut at this time.

**Related Adjustment:**  
FEED PAWL — FINAL

(Front View)

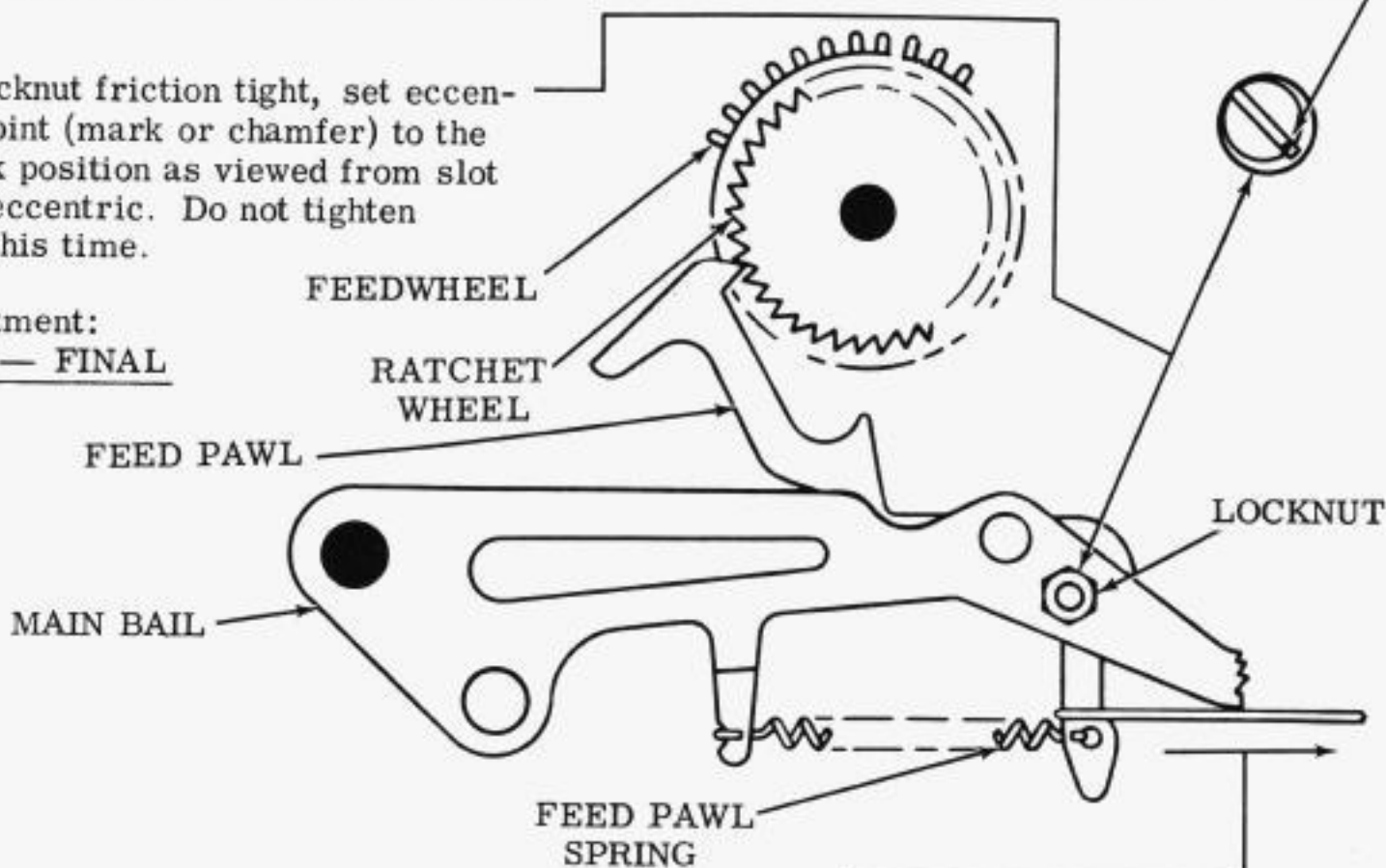

(B) FEED PAWL SPRING

**Requirement**

With the reader in the stop position and tilted to the left  
Min 2 oz---Max 3-1/2 oz  
to start pawl moving.

(C) TRANSFER LEVER SPRING

**Requirement**

With unit resting on its rear plate and main shaft in stop position  
Min 1/2 oz---Max 1-1/2 oz  
to start each lever moving.

(Front View)

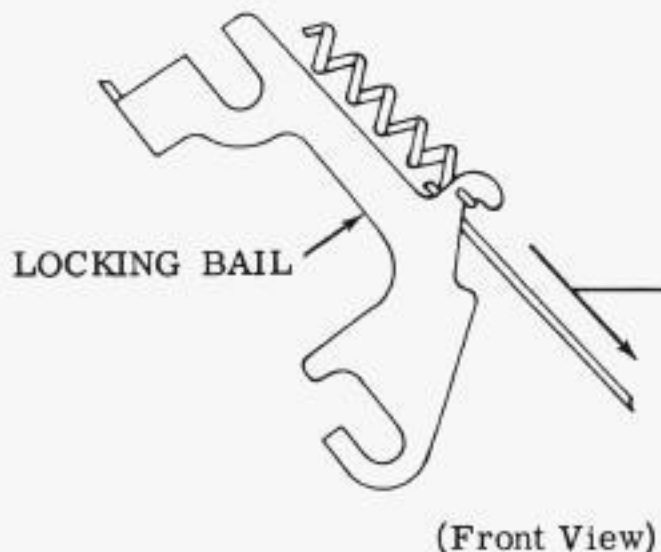

(D) LOCKING BAIL SPRING

**Requirement**

With the unit tilted toward the left and in stop position  
Min 10 oz---Max 14 oz  
to start bail moving.

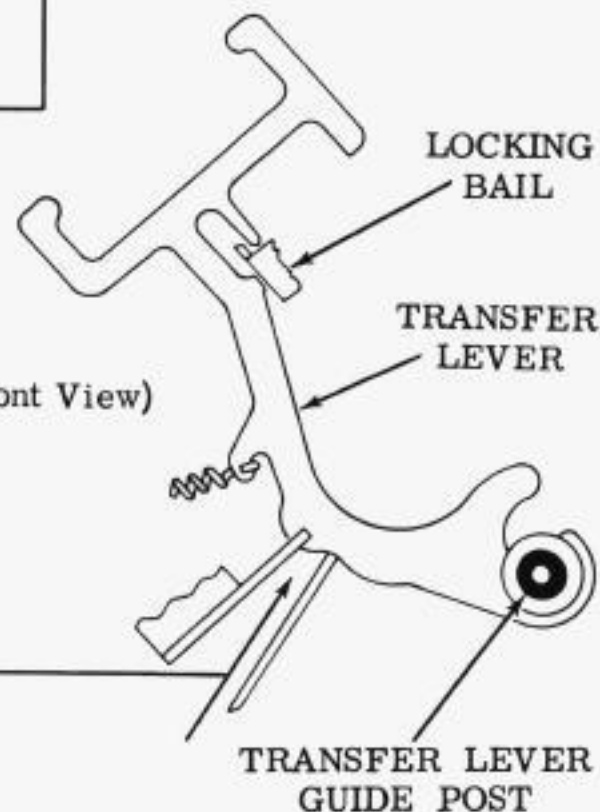

2.09 Idler Feedwheel and Tape Guide Mechanisms

IDLER FEEDWHEEL BRACKET

Requirement

The idler feedwheel should rotate freely in its slot in the top plate.

To Adjust

With the idler feedwheel bracket mounting nuts friction tight, position mounting bracket. Tighten nuts.

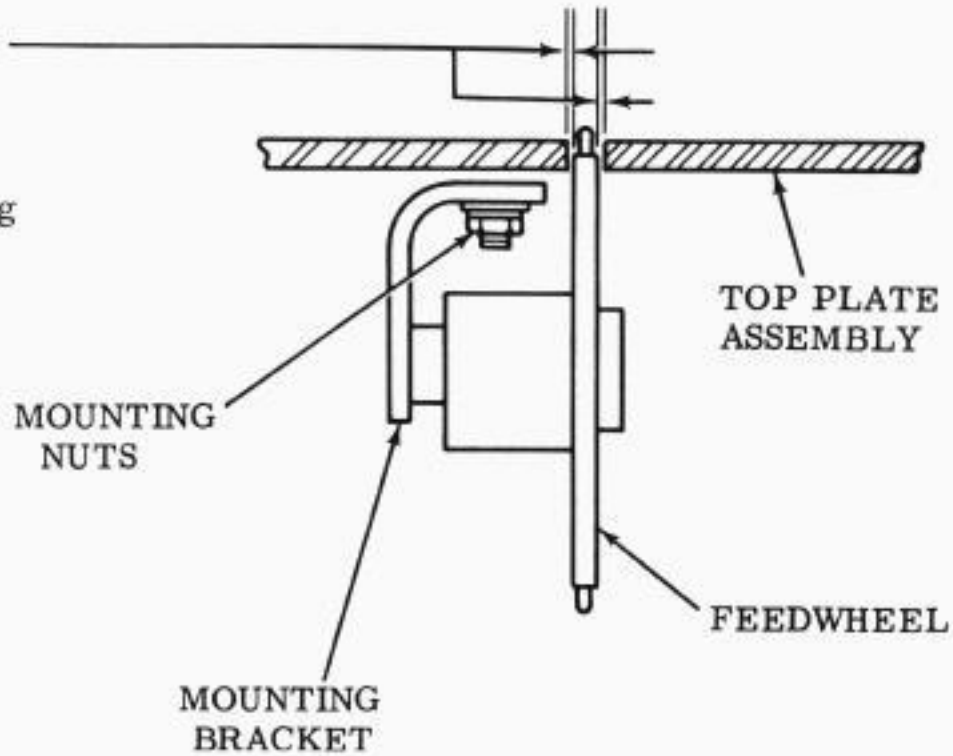

(Left Side View)

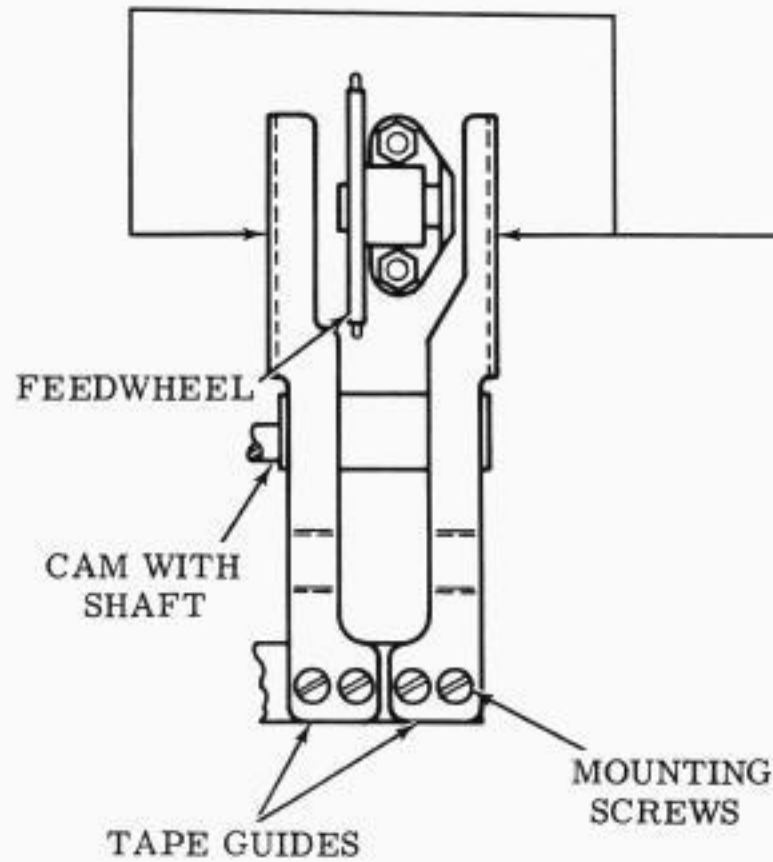

(Bottom View)

TAPE GUIDES

Requirement

With the card-tape switch lever moved to the tape position, the guides should pass through their slots in the top plate assembly without interference and a one inch tape should be able to pass between the guides freely.

To Adjust

Loosen mounting screws of both tape guides and position guides. Tighten screws.



2.10 Card-Out, Card-In, and Eject Contact Mechanism

Note: Adjustments (A) and (B) should be made prior to mounting of the contact assemblies.

(A) CARD-OUT, CARD-IN, AND EJECT CONTACT

Requirement

The normally open contact gap should be  
Min 0.007 inch---Max 0.015 inch

To Adjust

Bend the short normally open contact spring.

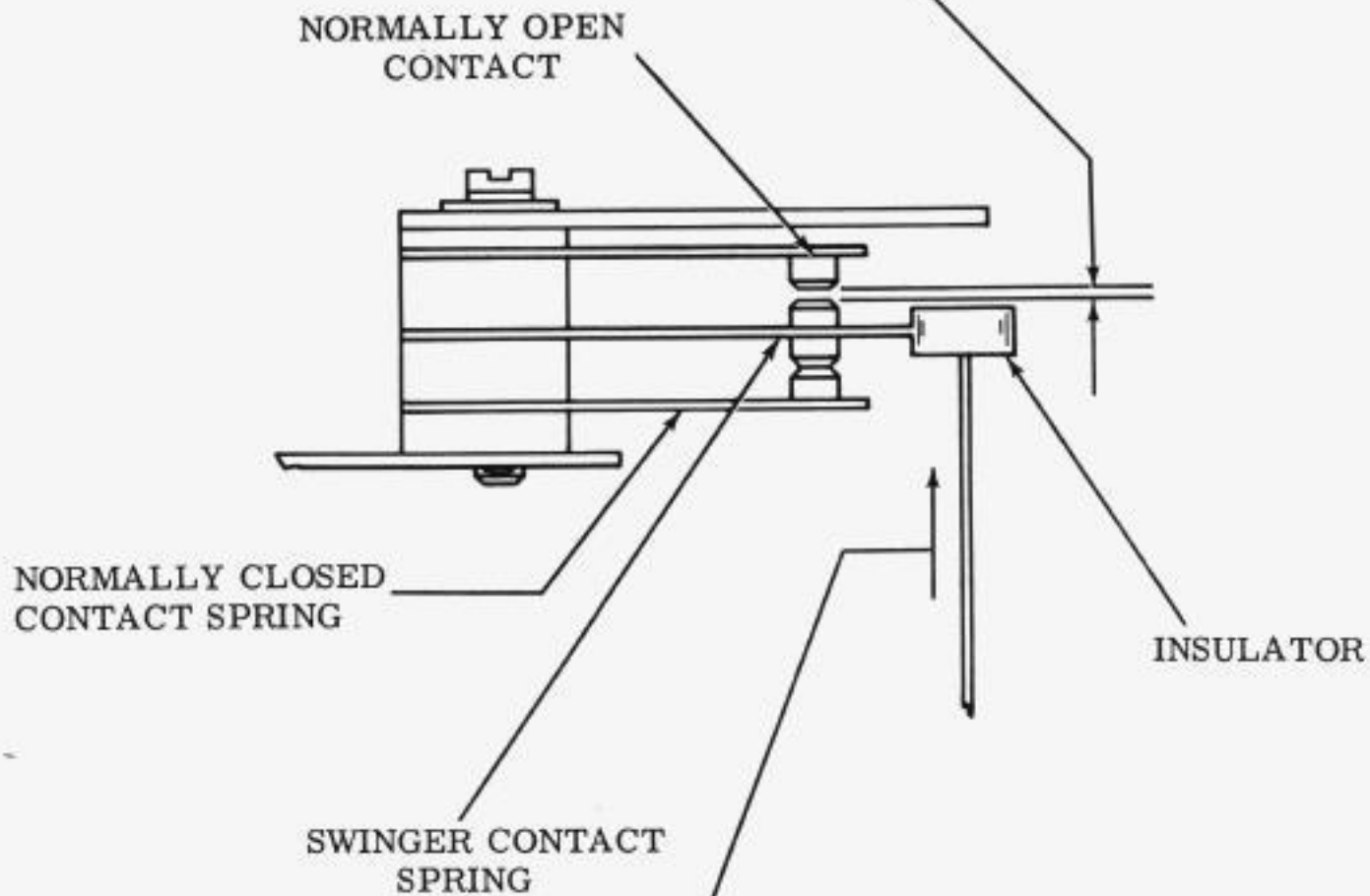

(Rear View)

(B) SWINGER CONTACT SPRING

(1) Requirement (Card-Out, and Card-In Contacts)

It should require a pressure of  
Min 14 grams---Max 28 grams  
to open the normally closed contacts.

(2) Requirement (Eject Contact)

It should require a pressure of  
Min 20 grams---Max 30 grams  
to open the normally closed contacts.

To Adjust

Bend swinger contact spring.

2.11 Eject Actuator Contact Assembly

EJECT ACTUATOR — PRELIMINARY

Requirement

The contact assembly and the contact springs should be in a horizontal position. With the nut friction tight, rotate the high part of the eccentric to the 12 o'clock position. Move the contact assembly mounting bracket to its topmost position by means of the slots in the bracket. Clearance between the plastic insulator on the swinger contact spring and the actuator extension of the switch lever

Min 0.010---Max 0.030 inch

To Adjust  
Rotate the eccentric. Tighten nut.

Related Adjustment:  
EJECT CONTACT ACTUATOR

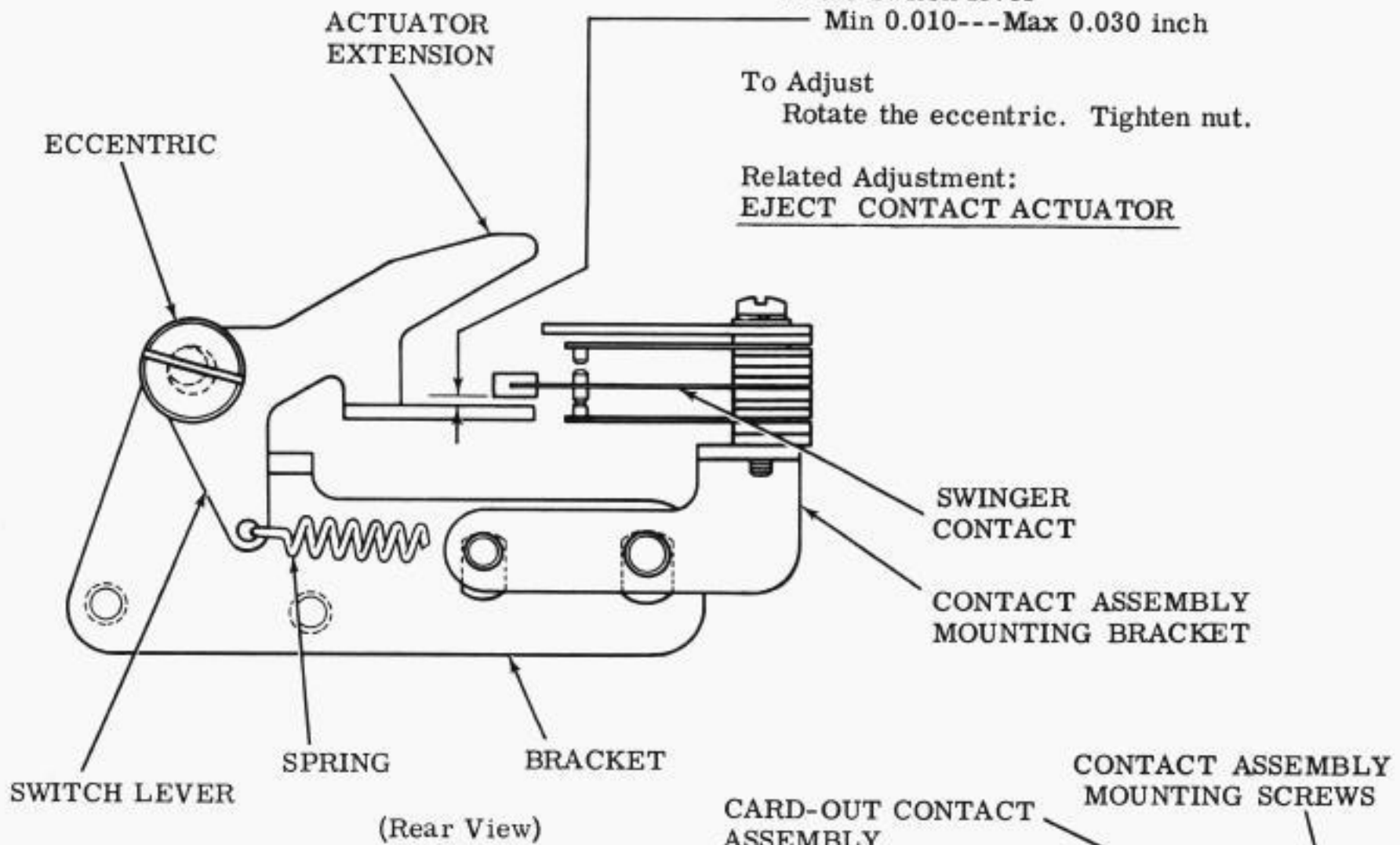

2.12 Card-Out Mechanism

CARD-OUT CONTACT ASSEMBLY

Requirement

The plastic swinger insulator of the contact assembly should be centered above the slot in its mounting bracket

To Adjust

With the contact assembly mounting screws friction tight center the insulator. Tighten the screws.

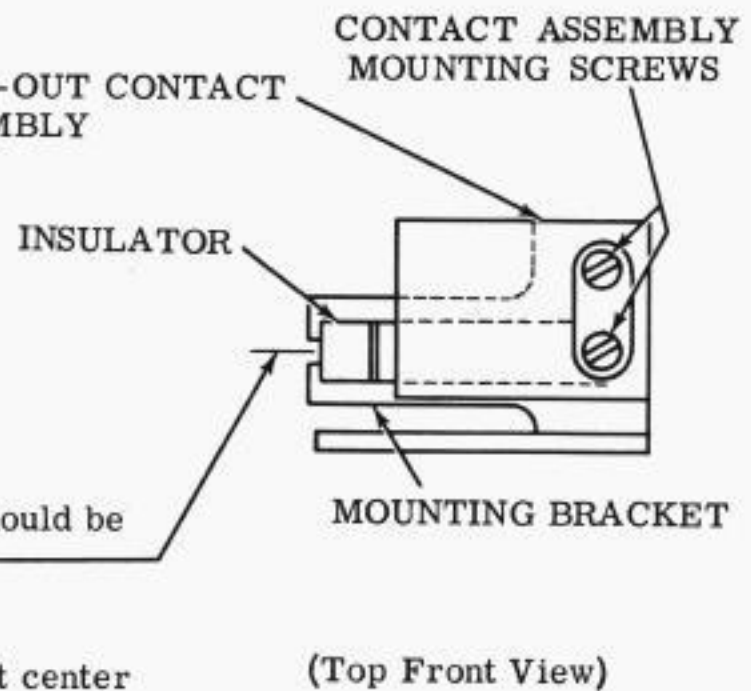

## 2.13 Drive Mechanism

GEAR BACKLASH

## Requirement

There should be a barely perceptible amount of backlash between the reader main shaft gear and its mating drive shaft gear at a point where the backlash is the least.

## To Adjust

With the two nuts holding the rear frame assembly and the screws holding the front frame assembly to the transmitter distributor assembly friction tight, position the rear frame for proper backlash. Tighten the nuts and screws.

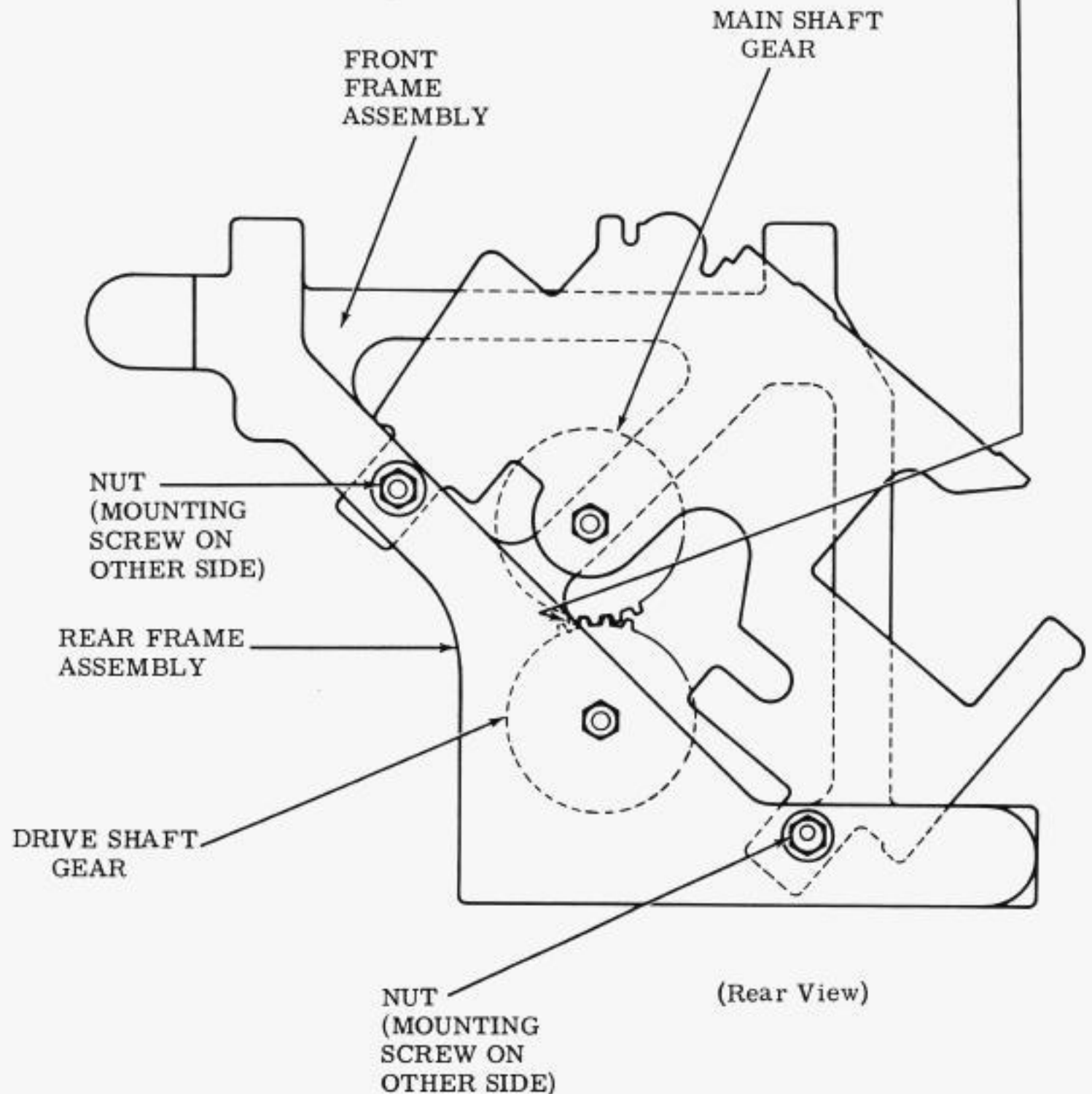



2.14 Top Plate Assembly (continued)

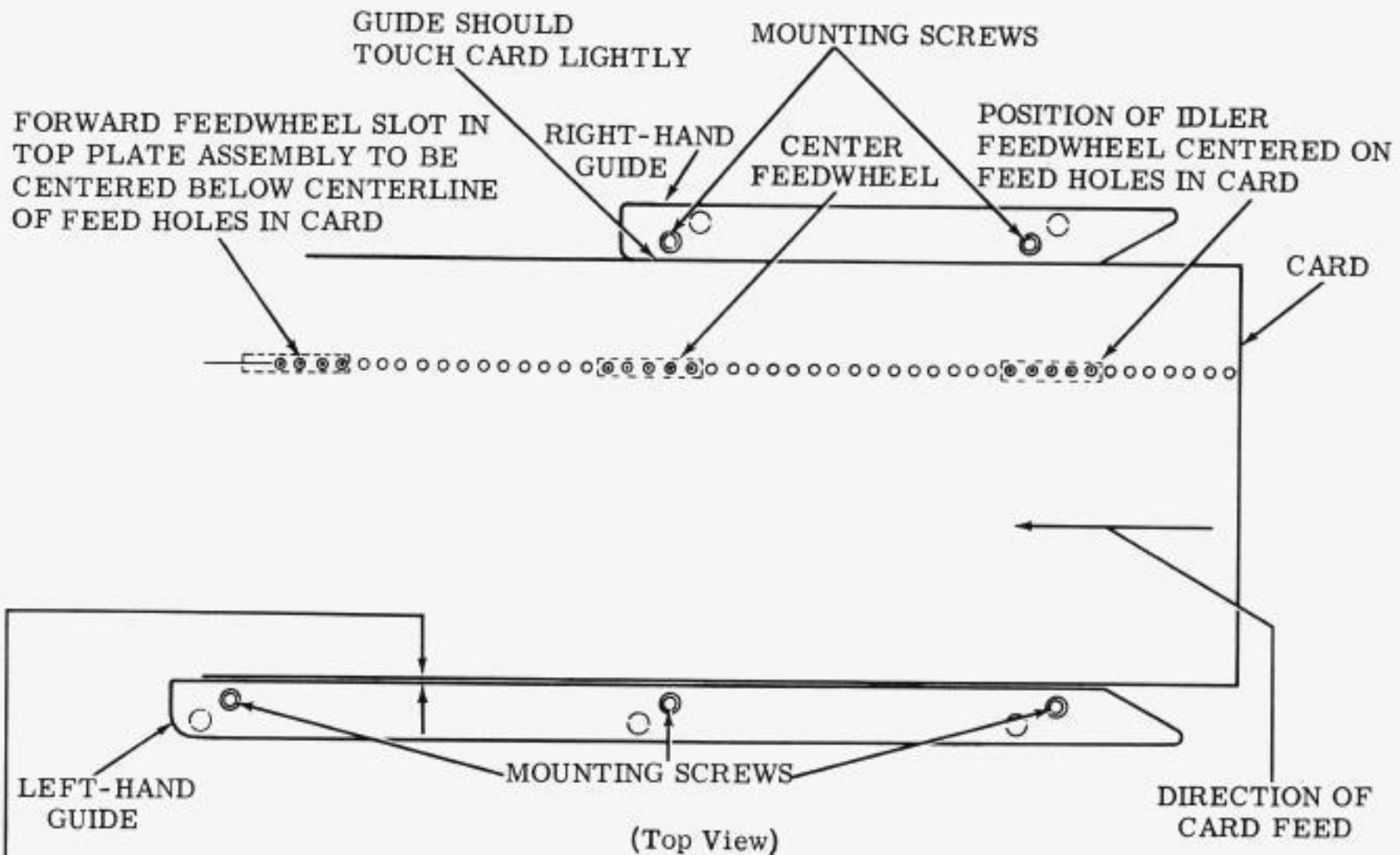

MAIN GUIDES

(1) Requirement

Place a fresh card between the guides on the top plate. The feed holes of the card should be centrally located on the pins of the idler feedwheel and above the centerline of the left-hand feedwheel slot in the top plate.

(2) Requirement

With the right-hand guide touching the inserted card, the clearance between the left-hand guide and the card should be  
 Min Some---Max 0.008 inch

**To Adjust**

Remove the left and right top guides to provide access to the guiding surfaces of the lower left and right guides. With the mounting screws of the left-hand and right-hand lower guides friction tight, move the guides outward.

Note: For normal use, the lower left-hand guide should be fastened to the top plate through the right-hand set of slots. For 3-1/2 inch wide cards, the guide should be fastened through the left-hand set of slots.

Place a freshly punched card on the top plate assembly the way it would be read by the reader. Center the feed holes in the card over the left-hand feedwheel slot. Align the front feed holes in the card over the forward feedwheel slot. Position the right-hand lower guide so that it will just touch the inserted card. Position the left-hand lower guide toward the card until its guiding edge is parallel to the edge of the card and there is some to 0.008 inch clearance between the guide and the card. Tighten the mounting screws of the lower guides. Replace the top guides.

2.15 Feedwheel Mechanism

FEEDWHEEL PHASING — PRELIMINARY

Requirement

Loosen the adjusting nut on the idler gear stud and the nut on the feedwheel mounting bushing so they are friction tight.

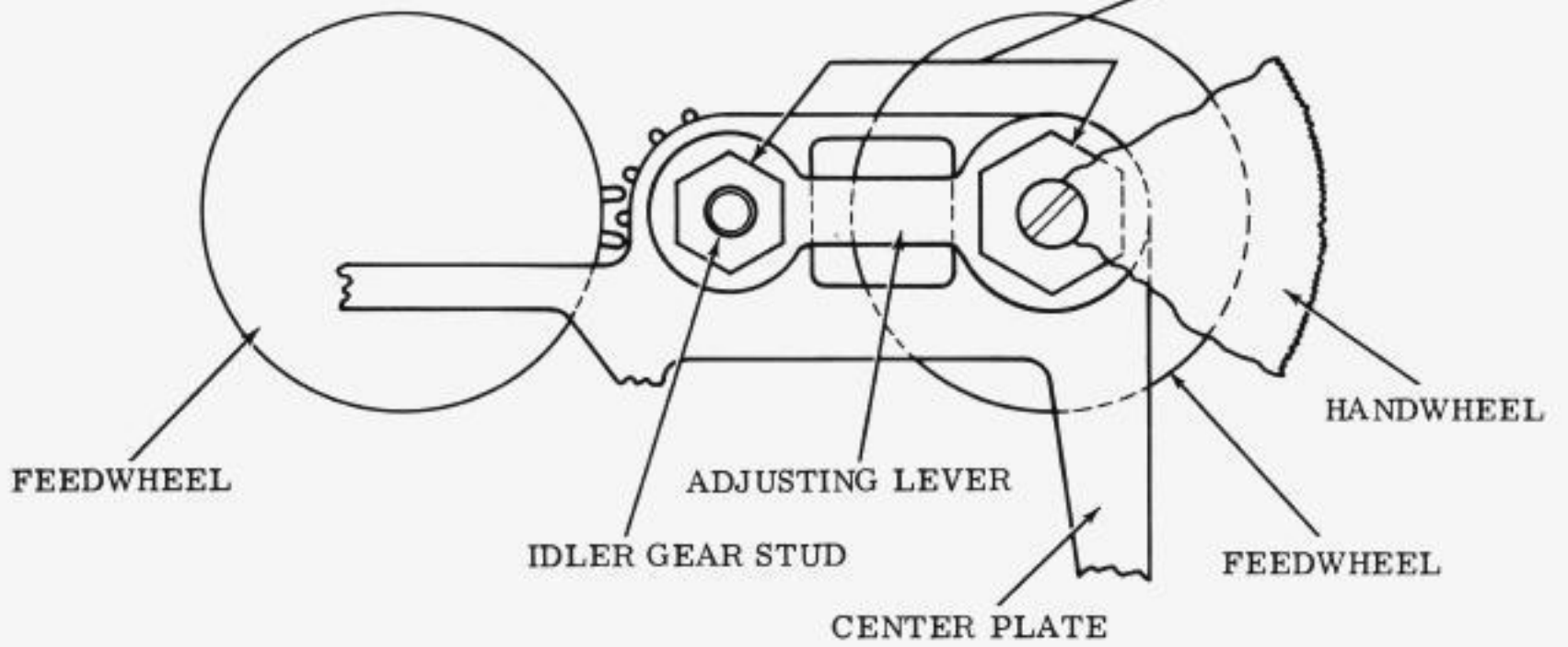

(Rear View)

## 2.16 Top Plate Assembly (continued)

Note: The following adjustments are made with the top plate assembly mounted to the reader. Place the tape-card switch into the card position to avoid interference with top plate positioning and possible damage to the tape-card switch during the following adjustments.

(B) TOP PLATE — HORIZONTAL

## (1) Requirement

The center feedwheel should be in line with the front feedwheel and idler feedwheel.

## (2) Requirement

The tip of the card-out sensing finger should be in the center of its hole in the lid of the top plate assembly. Refer to figure in LID CARD GUIDE adjustment for view of both requirements.

## To Adjust

Loosen the screws that hold the nut plate and switch bracket to their mounting brackets. The motor start relay bracket may be rotated to gain access to the corner mounting screw. With the lid manually depressed and a fresh card in the top plate guides, position the top plate assembly laterally and forward to meet the requirements. Tighten screws.

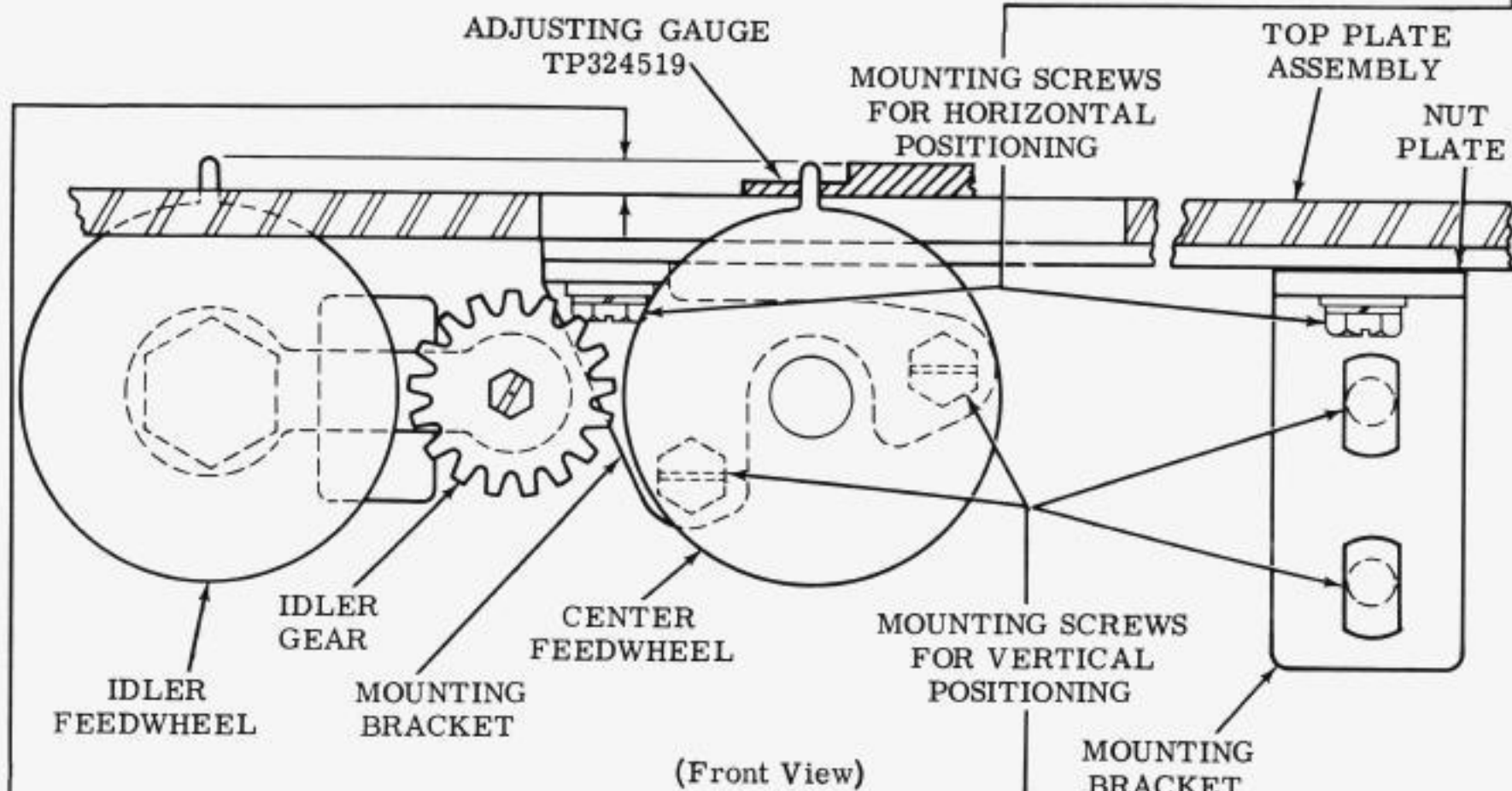
(A) TOP PLATE — VERTICAL

## Requirement

The clearance between the top plate assembly and the highest point of the pins on the feedwheels should be

Min 0.040 inch---Max 0.050 inch

## To Adjust

Loosen the mounting screws holding the top plate mounting brackets to friction-tightness. Remove the top guide, and top lid from the top plate assembly. Manually depress the lid against its stop and hold in that position. Using the adjusting gauge, position the top plate assembly to the required height. The tip of the most vertical pin (on both feedwheels) should be within the step on the adjusting gauge. Tighten the screws and replace the top guides, making sure that the guide springs are centrally located over the feedwheels.



## 2.17 Top Plate Assembly (continued)

(A) LID SPRING

## Requirement

The lid should be spring loaded in the open position. The top plate assembly should be in its normal horizontal position. Apply the push end of the scale to the front of the lid at the tab which holds the extension with pin.

Min 2-1/2 oz---Max 3-1/2 oz  
to fully close the lid.

## To Adjust

With spring mounting nut loosened, position the spring in its slot to obtain the requirement. Tighten the nut. Recheck requirement and refine if necessary.

(B) LID POSITIONING

## (1) Requirement

The lid shall be centrally located in its opening in the top plate assembly.

## (2) Requirement

There shall be a barely perceptible amount of side play between the lid and the hinges.

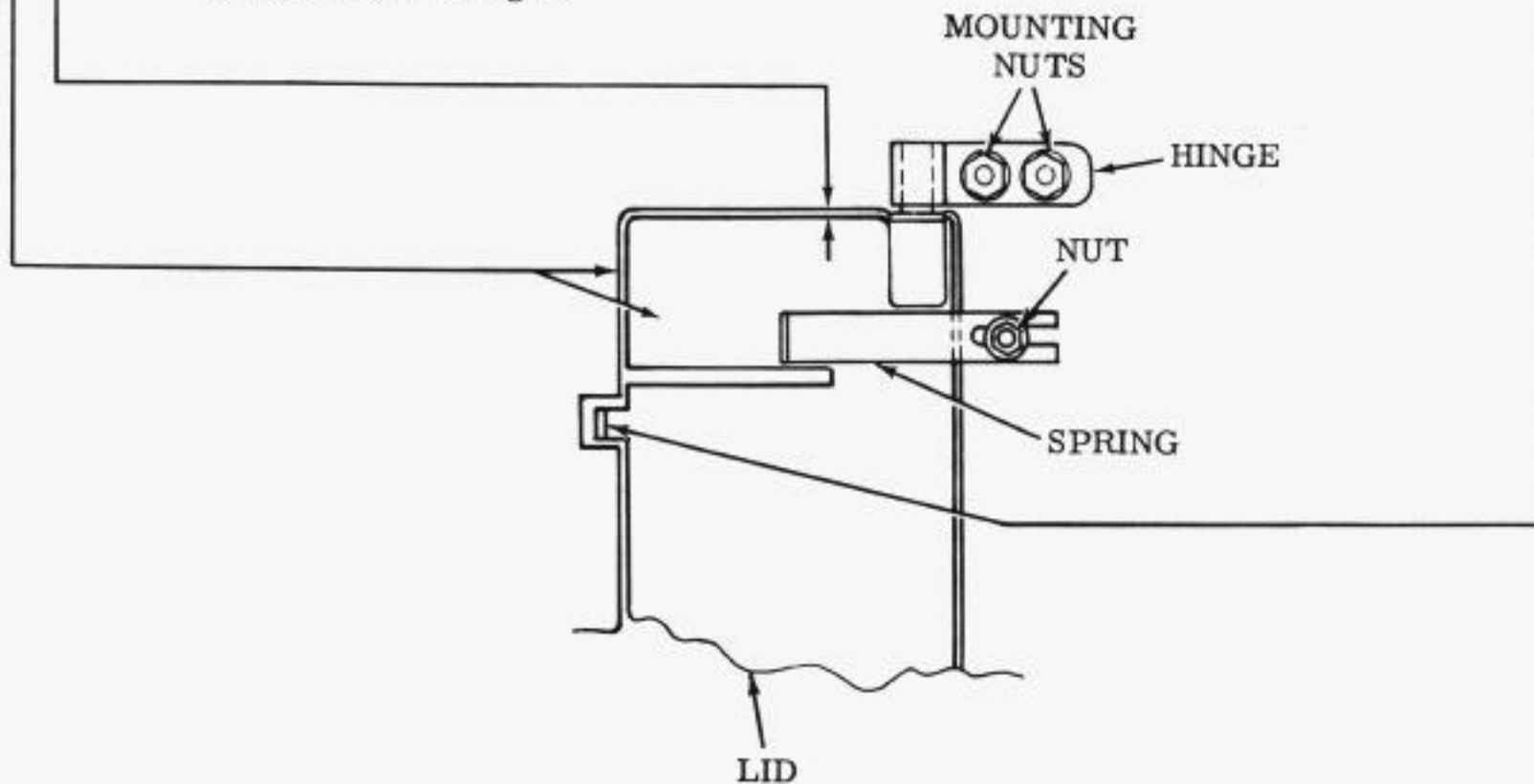

(Bottom View)

## To Adjust

Loosen the four nuts mounting the two hinges to friction tightness. Position the lid and the hinges to meet the requirement. Tighten the four mounting nuts.

## 2. 18 Top Plate Assembly (continued)

LID CARD GUIDE

## Requirement

With the lid in the top plate assembly held down and the reader clutch tripped, the sensing fingers should pass through their respective slots in the top lid without touching the sides of the slots. The card-out sensing finger and the card-in actuator should move freely in their respective slots. The lid spring should be centrally located with respect to the feed pins.

## To Adjust

With the three mounting screws friction tight, position the top lid and spring. Tighten screws.

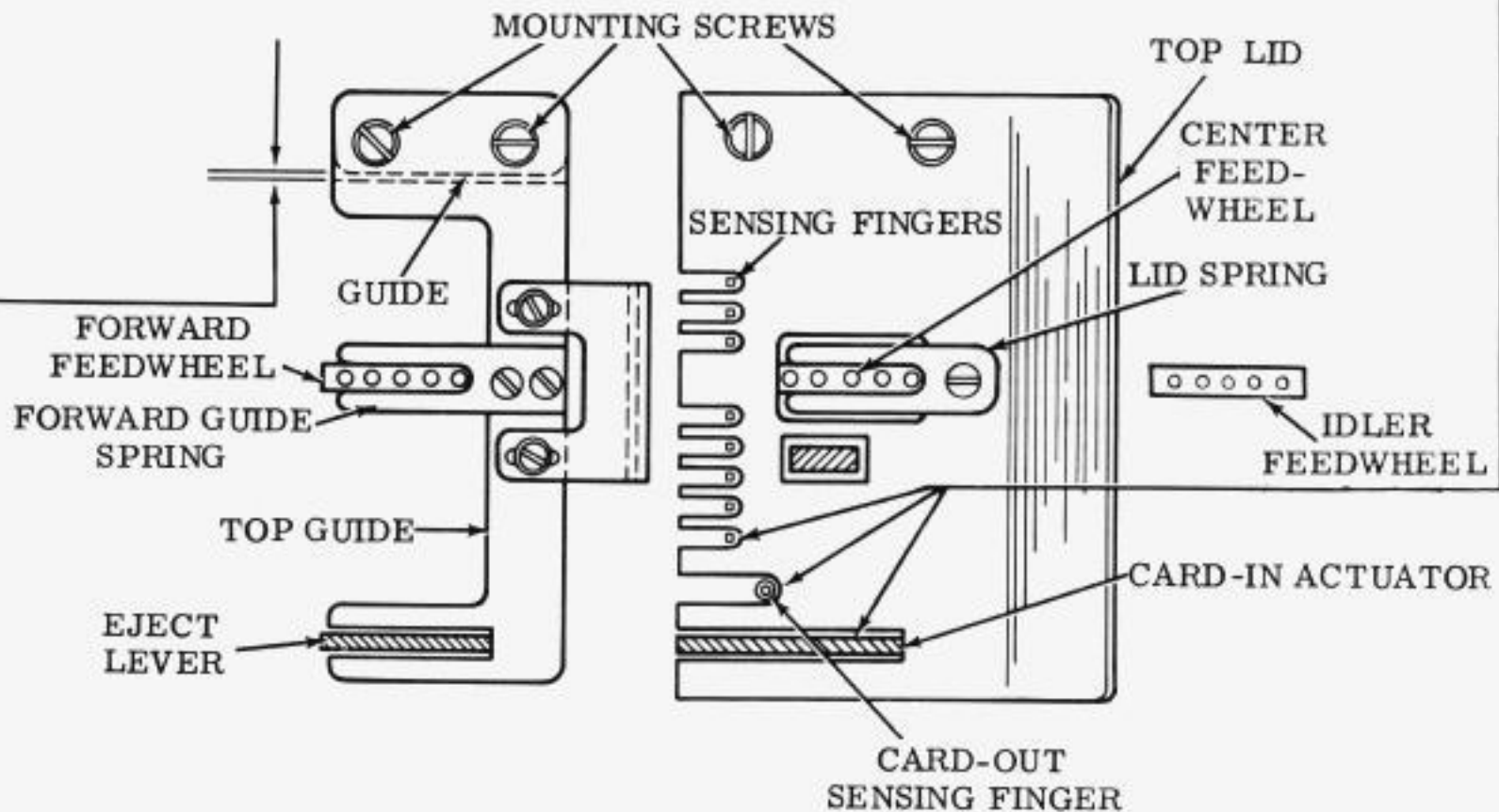

(Top Front View)

FORWARD GUIDE

## (1) Requirement

With card positioned over the feedwheel, there should be some clearance between edge of card and the guide.

## (2) Requirement

The top guide should not interfere with the operation of the eject contact lever.

## To Adjust

With mounting screws friction tight, position guides. Check for clearance between the guide spring and feedwheel pins. Tighten screws.

2.19 Code Sensing Fingers

SENSING HOLE ALIGNMENT

**Requirement**

With the reader clutch latched, a freshly punched card (all code holes marking) in the sensing area, and the lid of the top plate assembly held down, the tips of the sensing fingers should be centrally located under the corresponding code holes. The play in the feed holes of the card should be taken up, lightly, to the right.

**To Adjust**

The high point or marked side of the feedwheel detent eccentric should be set near the one o'clock position, until the tips of the sensing fingers are centrally located under the code holes. Hold detent assist from ratchet wheel when rotating eccentric. (See Detent Assist Assembly adjustment for location of detent).

Note: It may be necessary to keep the card centered, manually, on the feedwheel pins as the eccentric is moved.

Note: If the adjustment cannot be met, or if the sensing fingers are skewed in the code holes, it will be necessary to refine the GUIDE PLATE — PRELIMINARY adjustment. Note the amount and direction of misalignment between the sensing fingers and code holes. Remove the top plate assembly. Refer to the adjustment covering the guide plate and position the guide plate to correct the misalignment. Replace the top plate assembly, reinsert the card and recheck the adjustment. If it was necessary to move the guide plate, recheck the TOP PLATE — HORIZONTAL adjustment.

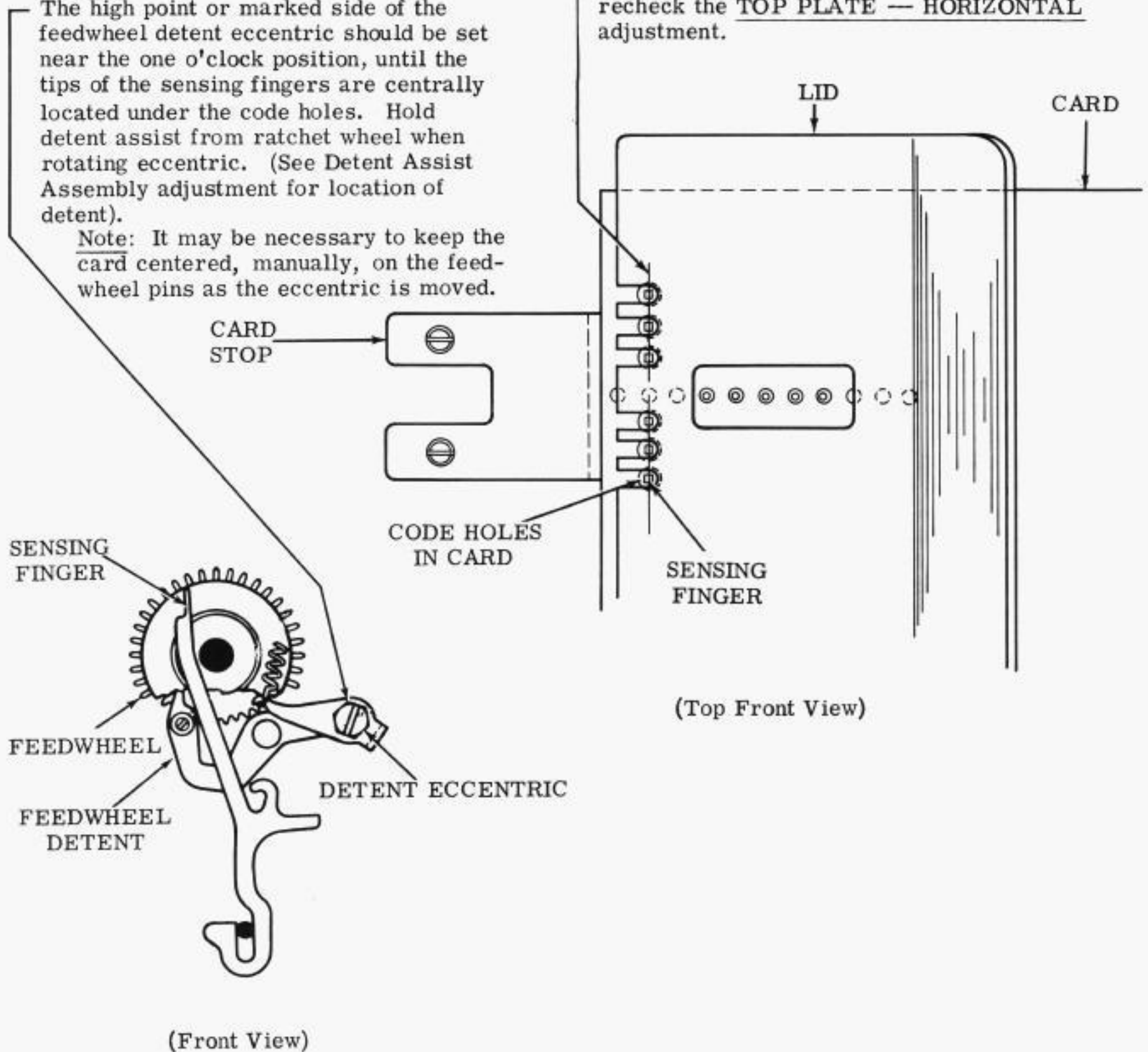



2.20 Card Stop and Tape Switch Mechanism

CARD STOP

Requirement

A card inserted into the reader must be stopped by the card stop to bring the first code position into line with the sensing fingers.

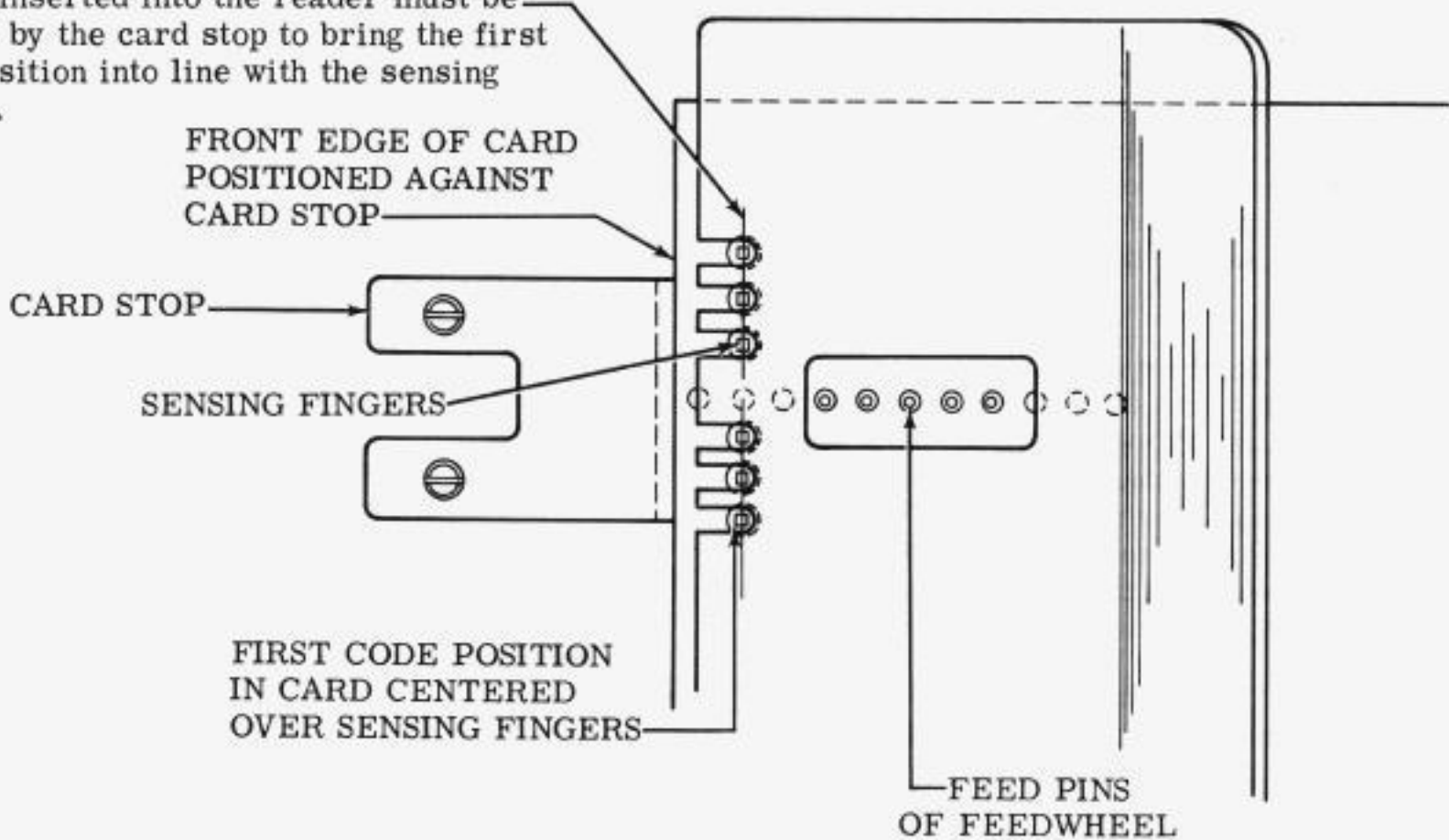

(Top Front View)

To Adjust

With the card stop mounting screws friction tight, position the card stop so that the restraining edge of the stop is squarely against the leading edge of the card. The feed holes in the card should be over the feed pins of the feedwheel and the first code hole position in line with the sensing fingers. Tighten the screws.

TAPE SWITCH

Requirement

With the switch lever in the tape position and the plunger of the switch depressed fully, clearance between the switch plunger and the camming surface of the switch lever

Min Some --- Max 0.010 inch

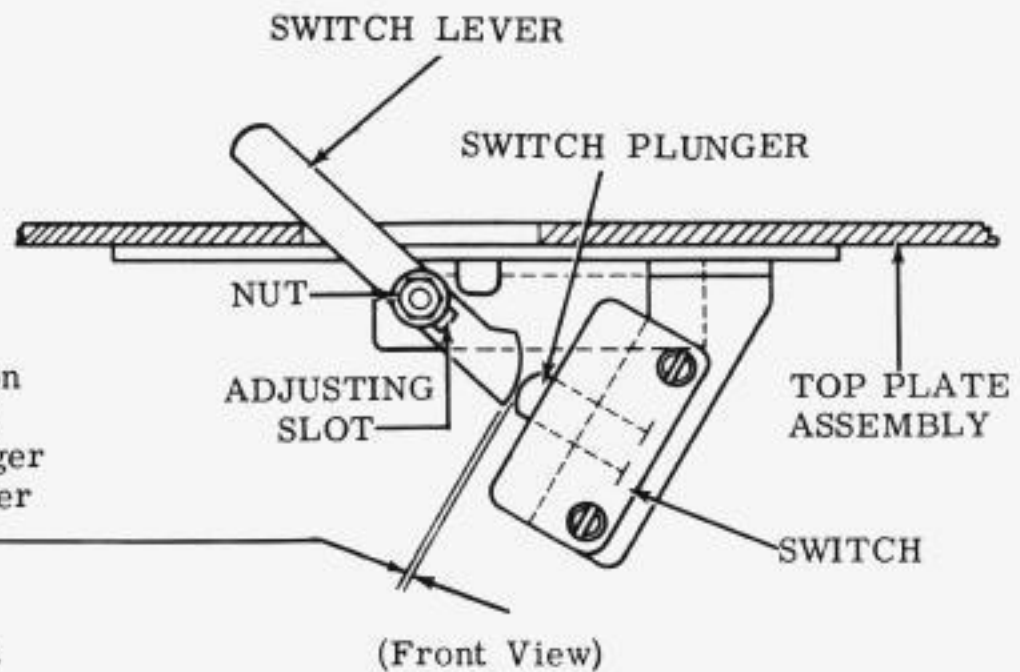

(Front View)

To Adjust

With the nut on the switch lever friction tight and the switch lever in the tape position, insert a 0.010 inch flat wire gauge between the switch plunger and the camming surface of the switch lever. Position the switch lever, by means of its slot, towards the switch until the plunger bottoms. Tighten nut.

## 2.21 Feedwheel Mechanism (continued)

FEEDWHEEL PHASING — FINAL

## Requirement

The two feedwheels must be phased to engage the feed holes of the card equally.

## To Adjust

Remove handwheel to gain access to the adjustment. Insert card into reader until the forward and center feedwheels engage the feed holes of the card. Manually hold down the lid while taking up the play in the forward feedwheel toward the rear of the card. Using the pry points in the center plate, position the idler gear stud by means of the adjusting lever, up or down, to meet the requirement. The most vertical feed pins of the forward and center feedwheels should just touch the front of their respective feed holes in the card. Recheck the adjustment using a fresh card.

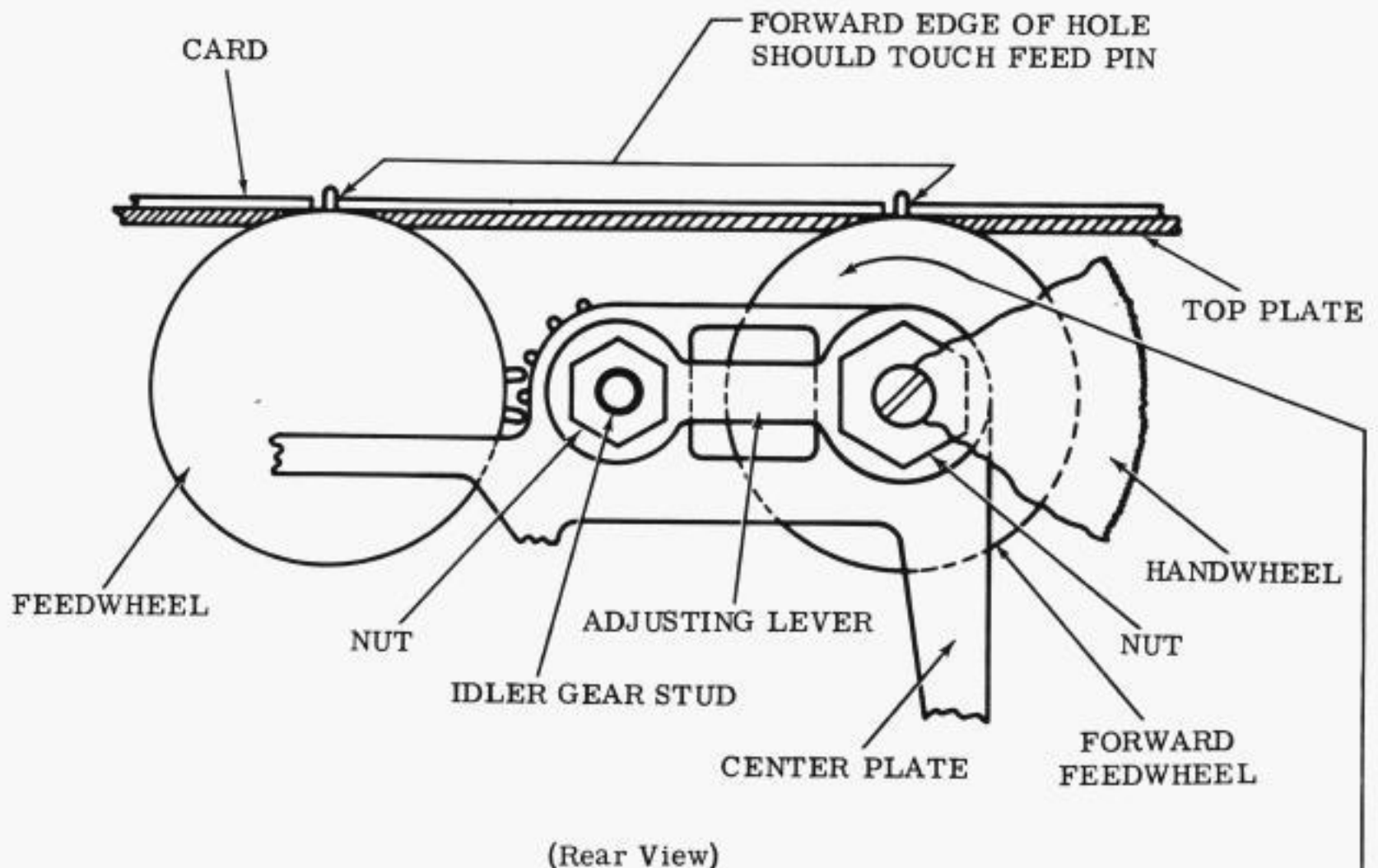

Play in forward feedwheel  
taken up toward the rear.

## 2.22 Main Bail Assembly (continued)

Note: Pivot the unit about its front shock absorbers to gain access to the following adjustments. Refer to appropriate disassembly-reassembly section for detailed instructions.

MAIN BAIL LATCHLEVER

## Requirement

With the reader clutch in its stop position and the lid fully depressed against its stops, the highest sensing finger should be

Min Flush---Max 0.005 inch  
below the upper surface of the lid in the top plate assembly.

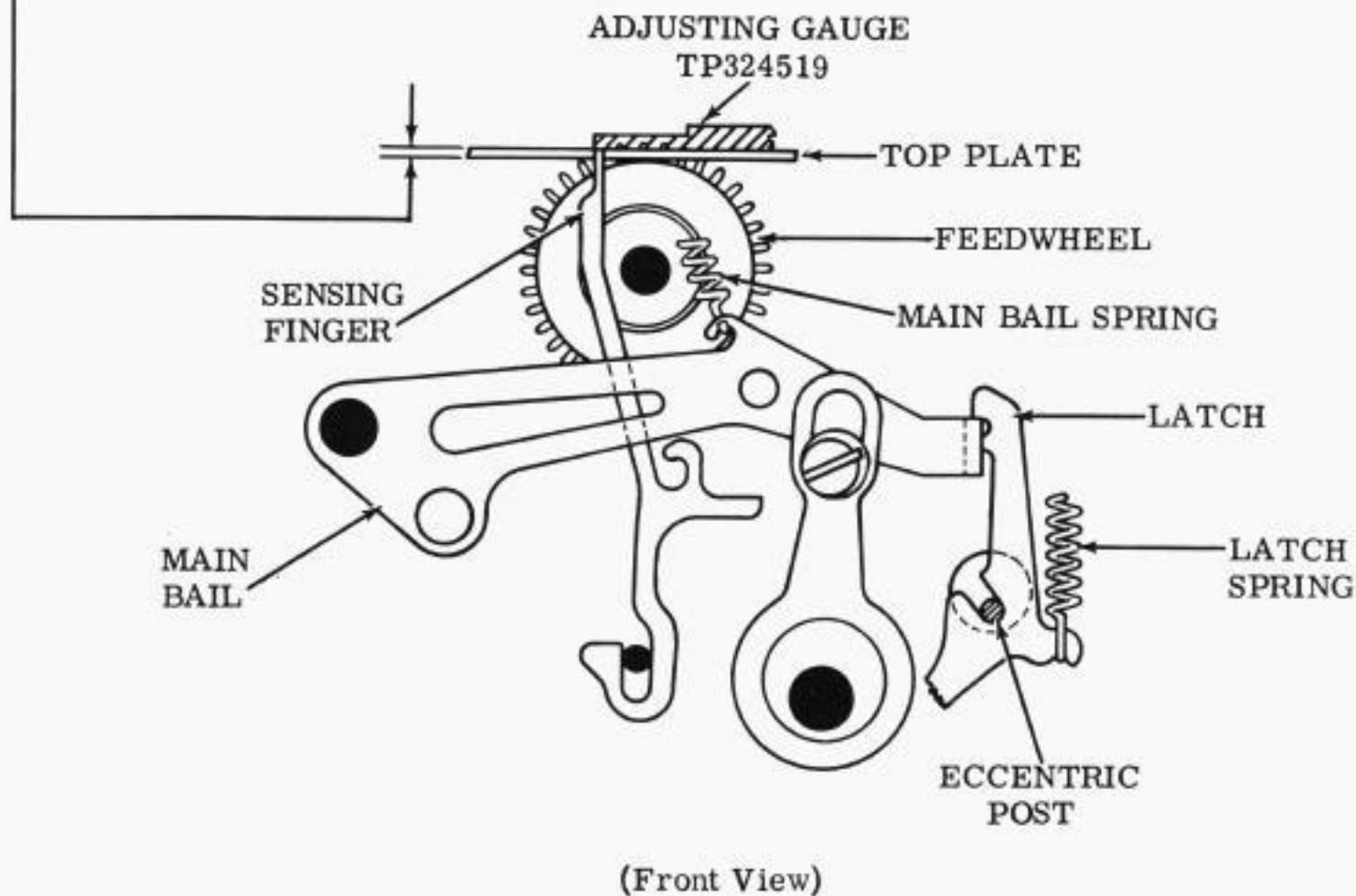

## To Adjust

Remove the top lid. Loosen the two nuts on the eccentric post friction tight. The adjusting gauge may be used as an aid in making this adjustment. With the lid depressed, place the slot in the adjusting gauge over the feed pins. Position the gauge over the ends of the sensing fingers. Rotate the eccentric post so that the required clearance exists between the bottom of the gauge and the top of the highest sensing finger. Replace the top lid, tighten the nuts and recheck.



## 2.23 Main Bail Assembly (continued)

SENSING FINGER SPRING

## Requirement

Unit in upright position, trip the clutch and place the sensing fingers in their uppermost position

Min 3 oz---Max 5 oz \_\_\_\_\_  
to move each sensing finger to a position flush with the tape guide plate.

MAIN BAIL SPRING

## Requirement

With the top plate removed and the main bail in its highest position, apply push end of scale on the front main bail plate, perpendicular to the plate and near the spring extension.

Min 10 oz---Max 15 oz \_\_\_\_\_  
to start main bail moving.

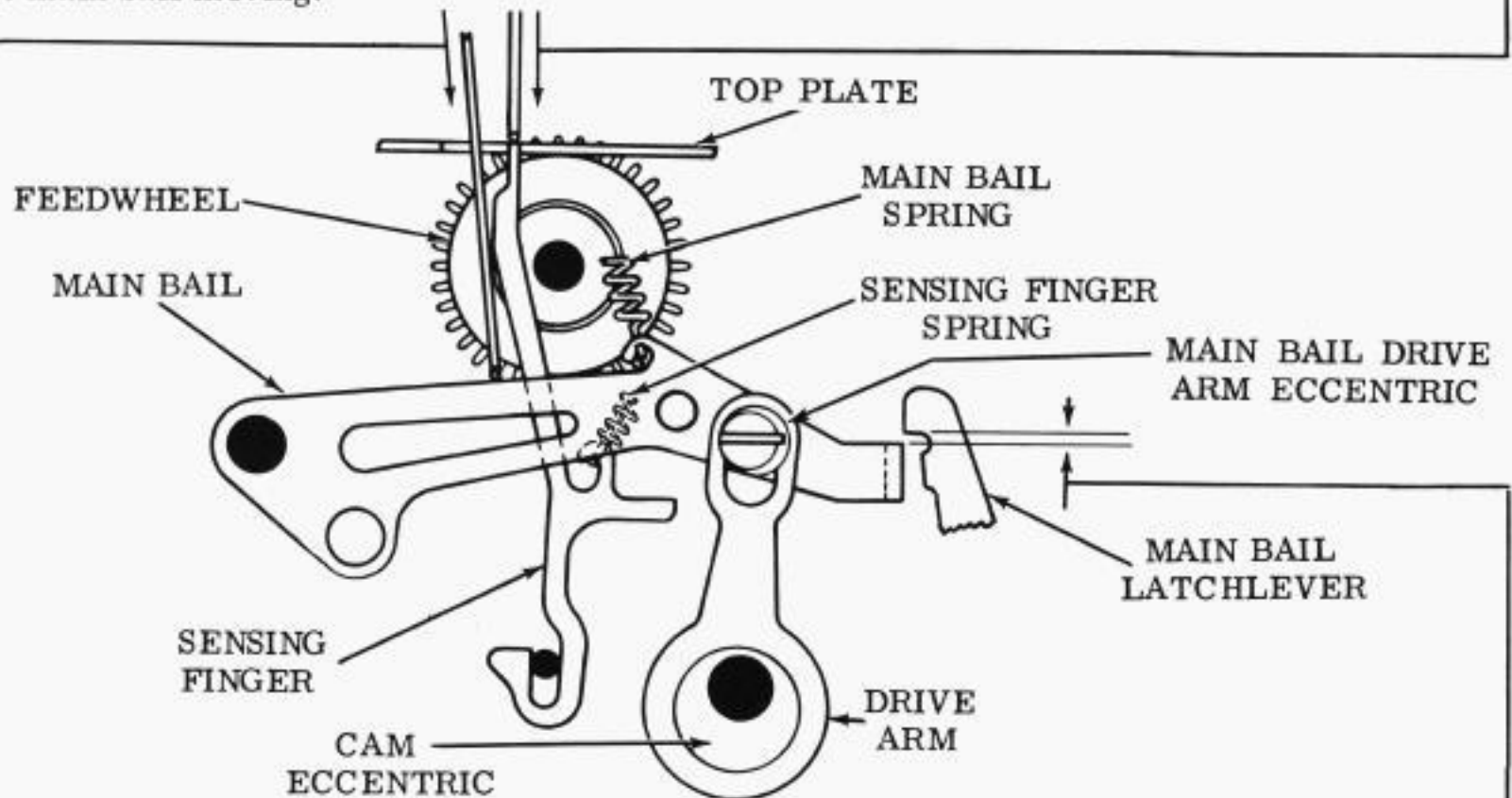

(Front View)

MAIN BAIL

## Requirement

With the main bail in its lowermost position, there should be

Min some---Max 0.015 inch \_\_\_\_\_  
horizontal gap between the arm on the main bail and the main bail latchlever.

## To Adjust

With the nut on the main bail drive arm eccentric friction tight, rotate the eccentric until the requirement is met. The eccentric mark should be near the three o'clock position.

## Related Adjustments:

MAIN BAIL DRIVE ARM — PRELIMINARY

FEED PAWL — FINAL

2.24 Clutch Trip Mechanism

(A) CLUTCH TRIP LEVER

Requirement

With the stop lug of the clutch disc opposite the clutch trip lever, there should be

Min 0.012 inch---Max 0.025 inch clearance between the lug and the lever when the play is taken up to make the clearance a maximum. There should be some clearance between the trip lever and the lug of the clutch disc when measured at its closest point.

To Adjust

With the nut on the clutch trip bail eccentric friction tight and the eccentric in its lowermost position, rotate the eccentric until the requirement is met. Tighten the nut. Recheck adjustment and refine if necessary.

(B) CLUTCH SHOE LEVER

Requirement

Clearance should be  
Min 0.055 inch---Max 0.085 inch greater with clutch engaged than with clutch disengaged. Pull shoe lever with a force of 32 ounces and release slowly to engage clutch shoes.

To Adjust

With clutch disc clamping screws loosened, place wrench over stop lug and position disc. Tighten clamp screws.

**CAUTION: MAKE SURE THAT DRUM DOES NOT DRAG ON SHOES WHEN CLUTCH IS DISENGAGED AND DRUM IS ROTATED IN ITS NORMAL DIRECTION OF ROTATION. REFINE ABOVE ADJUSTMENT TOWARDS MAXIMUM TO ELIMINATE SHOE DRAG.**

(D) CLUTCH TRIP LEVER SPRING

Requirement

With clutch engaged  
Min 7 oz---Max 10-1/2 oz to start clutch trip lever moving.

(C) CLUTCH LATCHLEVER SPRING

Requirement

Clutch engaged and rotated until latchlever is on low part of disc

Min 3 oz---Max 5-1/2 oz to start latch moving.

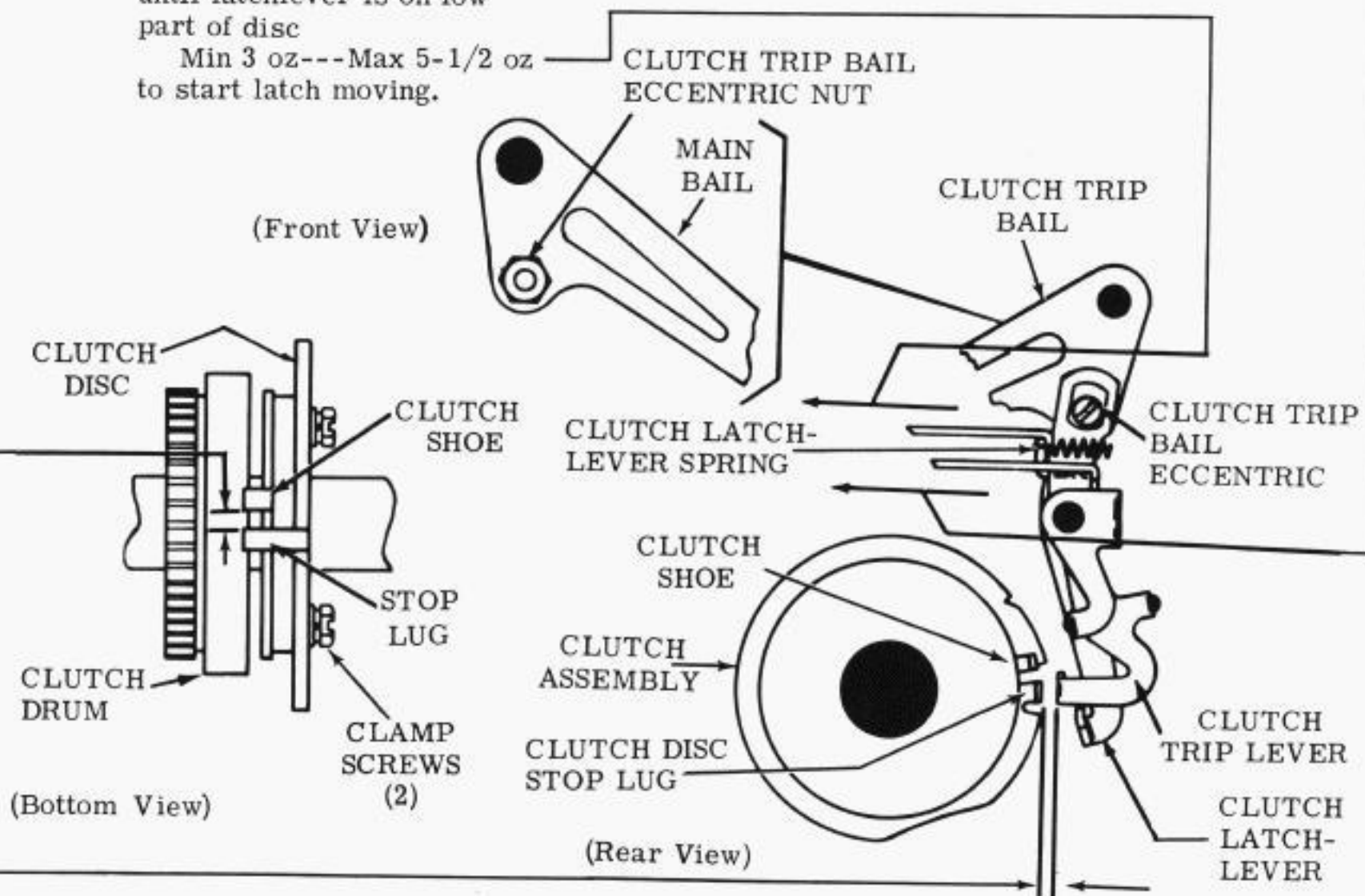

2.25 Clutch Trip Magnet Assembly (continued)

(A) CLUTCH TRIP MAGNET ASSEMBLY — FINAL

(1) Requirement

With the clutch disengaged, clearance between the end of the extension on the armature bail and the main bail latch

Min 0.007 inch---Max 0.015 inch

(2) Requirement

With the armature in the attracted position, there should be a Min 0.005 inch

clearance between the vertical surfaces of the main bail and the main bail latchlever.

To Adjust

With magnet bracket mounting screws friction tight, mounting bracket with magnet assembly in lowermost position, and with the reader clutch disengaged, position the mounting bracket by means of its adjusting slot to meet the requirements. Tighten mounting screws.

Note: Replace the fan assembly at this time.

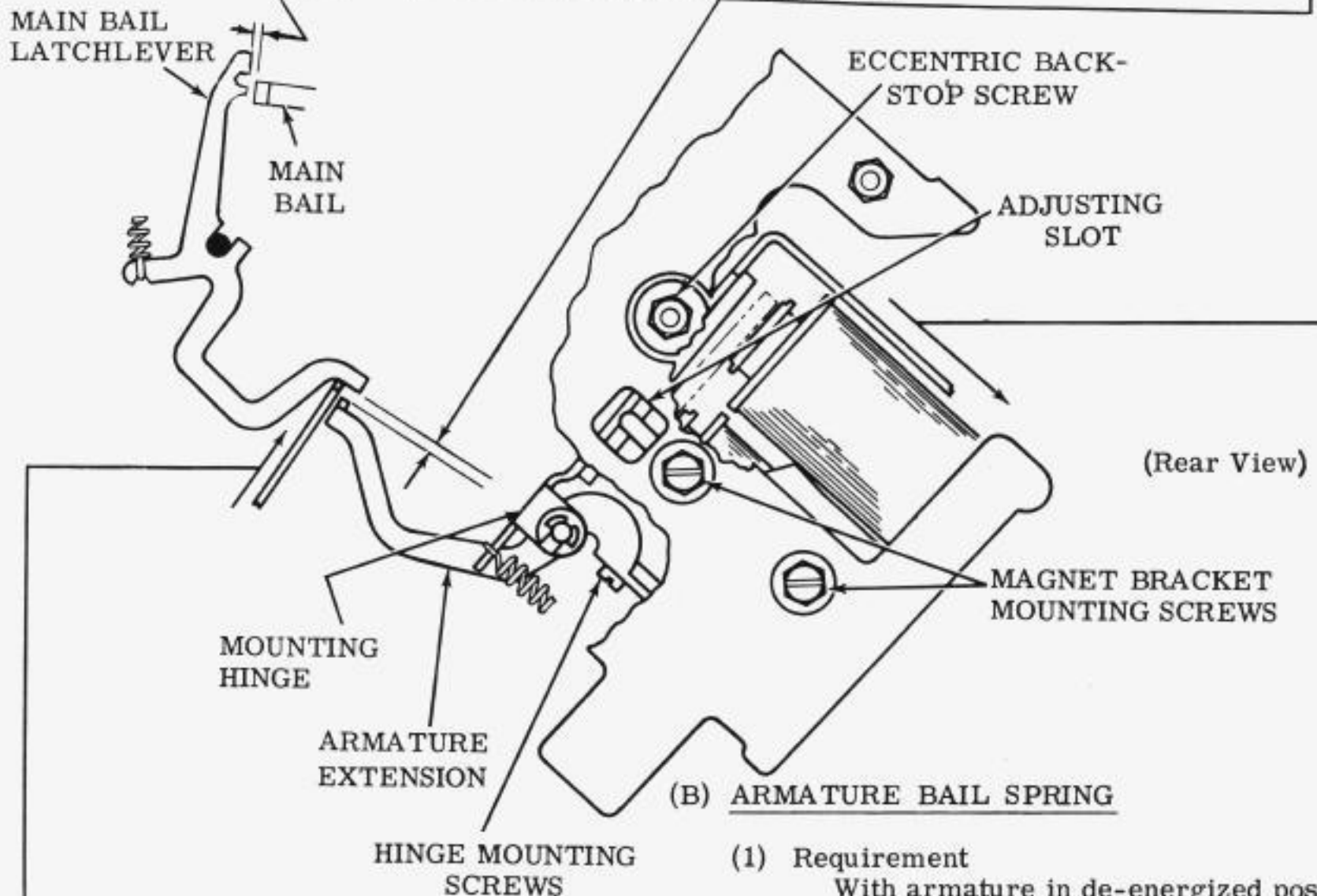

(B) ARMATURE BAIL SPRING

(1) Requirement

With armature in de-energized position and main bail latchlever held away

Min 3-1/4 oz---Max 4-3/4 oz to start armature moving.

(C) MAIN BAIL LATCH SPRING

Requirement

With unit inverted and main bail latch released

Min 3/4 oz---Max 2 oz to start main bail latch moving.



## 2.26 Feedwheel Mechanism (continued)

FEED PAWL — FINAL

## (1) Requirement

There should be backlash

Min Some---Max 0.003 inch  
between the feed pawl and the respective driven ratchet tooth when the main bail is at its lowermost position and the feedwheel detent lever has moved to the new detented position.

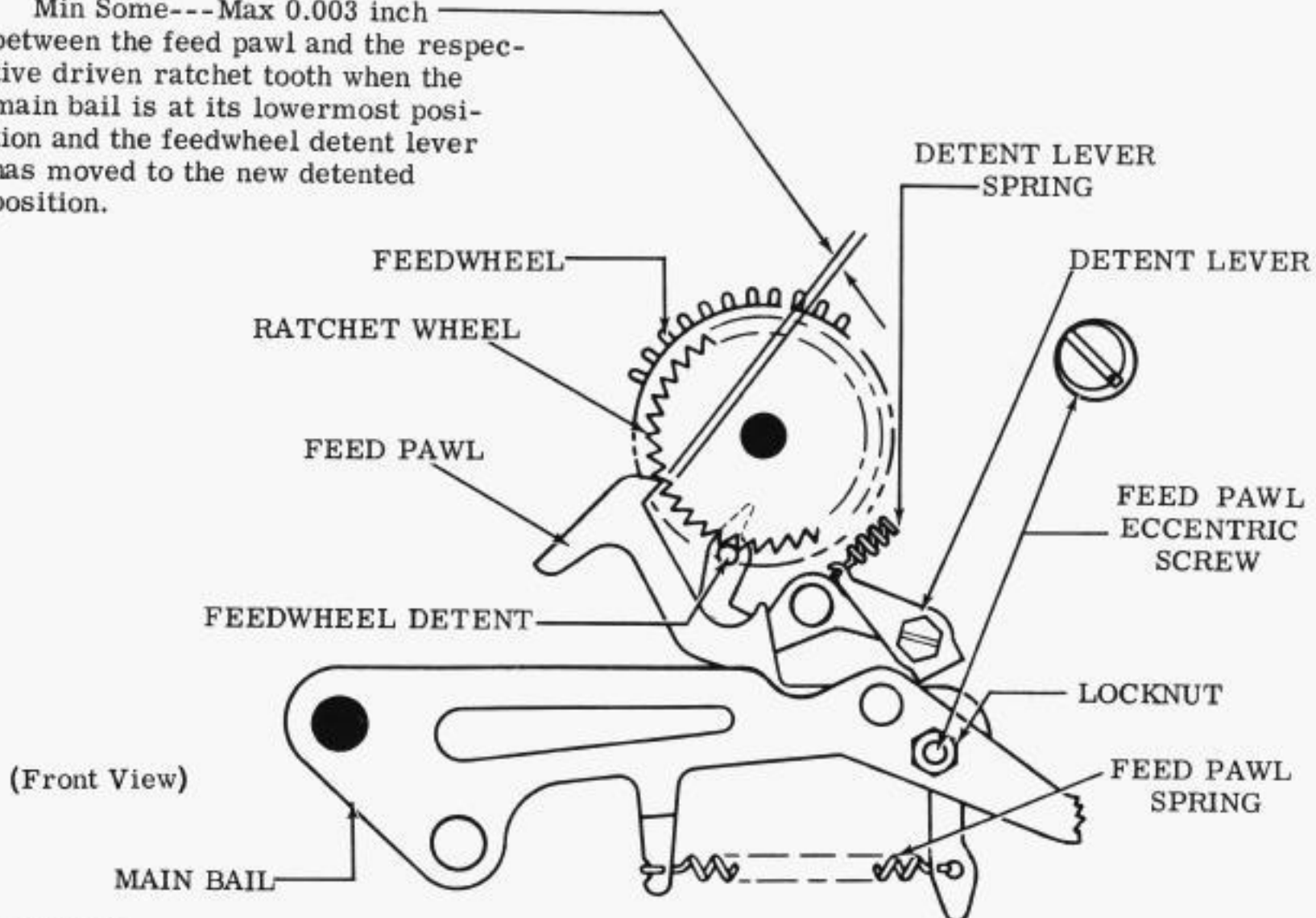

## (2) Requirement

When the shaft is rotated through several revolutions, there should be no noticeable overdrive of the feedwheel.

## To Adjust

Trip the main bail and rotate the drive shaft until the feed pawl reaches the lowermost position of its stroke and the feedwheel is detented. Rotate the feed pawl eccentric about the five o'clock position to meet the requirements.

**Note:** Return the unit to its normal position by following procedure outlined in disassembly-reassembly section for pivoting reader about its front shock absorbers.

Remove the top plate assembly for the following checks and adjustments:

- (1) FEED PAWL ECCENTRIC. Tighten the locknut of the feed pawl eccentric taking care not to disturb the adjustment.
- (2) FEEDWHEEL DETENT ECCENTRIC. Tighten the stud on the detent eccentric. Use wrench or screwdriver to hold the eccentric on set position.
- (3) MAIN BAIL DRIVE ARM ECCENTRIC. Tighten the locknut on the main bail drive arm eccentric taking care not to disturb the adjustment.
- (4) FEEDWHEEL PHASING — FINAL. Tighten the nut on the adjusting lever bushing and then the nut on the idler gear stud.



2.27 Detent Assist Assembly

(A) DETENT ASSIST ASSEMBLY

Requirement

With the cam follower detent roller on the high part of the eject release clutch cam, there should be a clearance of

Min Some---Max 0.008 inch

between the flat pusher edge of the detent and a tooth on the feedwheel ratchet. Clearance should be between detent assist and the 5<sup>th</sup> tooth from the most vertical tooth.

To Adjust

With the eccentric locknut friction tight, position the eccentric, keeping the high point to the left of a vertical line through its center (eccentric viewed from slot end) to meet the requirement. Tighten the locknut. Check the adjustment at several points around the ratchet.

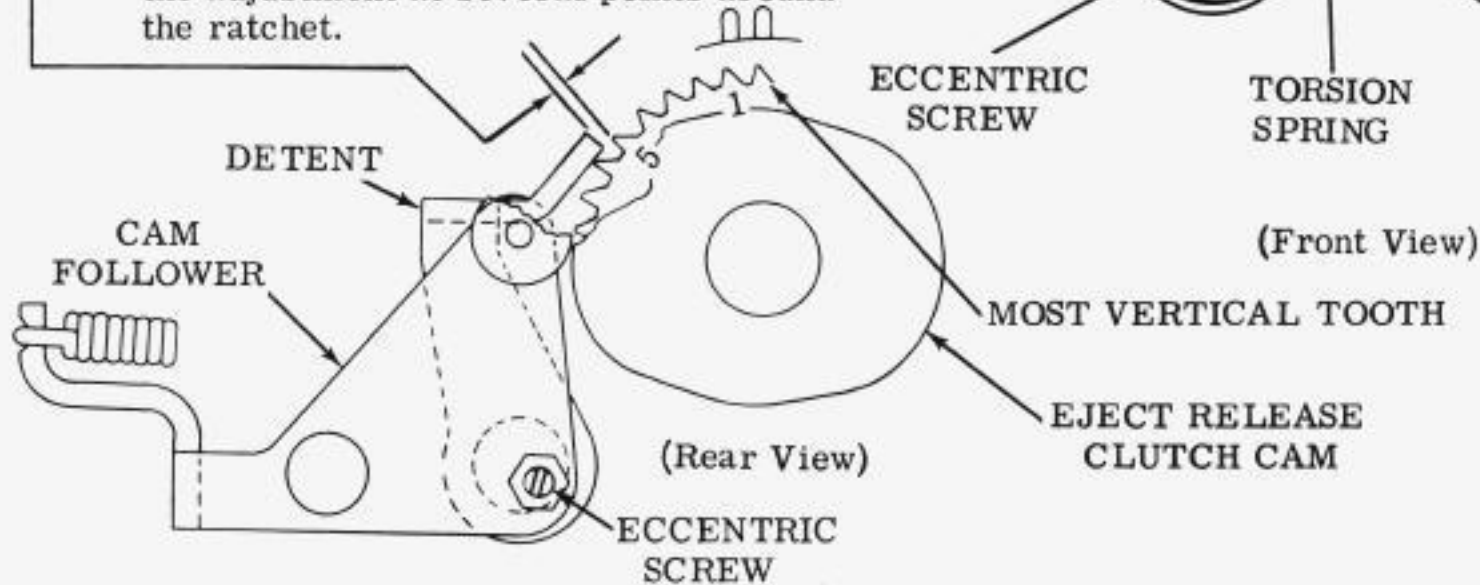

(B) DETENT ASSIST CAM FOLLOWER SPRING

Requirement

With the cam roller at the bottom of its cam, apply the pull end of the scale to the cam follower at the post.

Min 7-1/2 oz ---Max 10-1/2 oz to lift the roller off the cam.

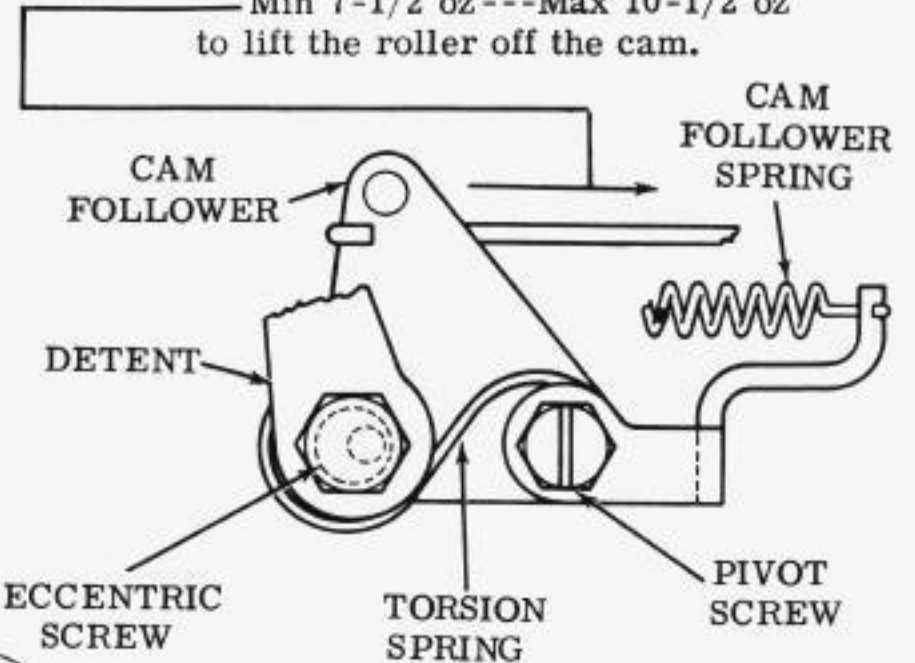

(Front View)

(C) DETENT ASSIST TORSION SPRING

Requirement

With the cam follower roller on the low part of the cam, it should require

Min 4 oz ---Max 6 oz

to lift the pusher extension of the detent off the feedwheel ratchet.

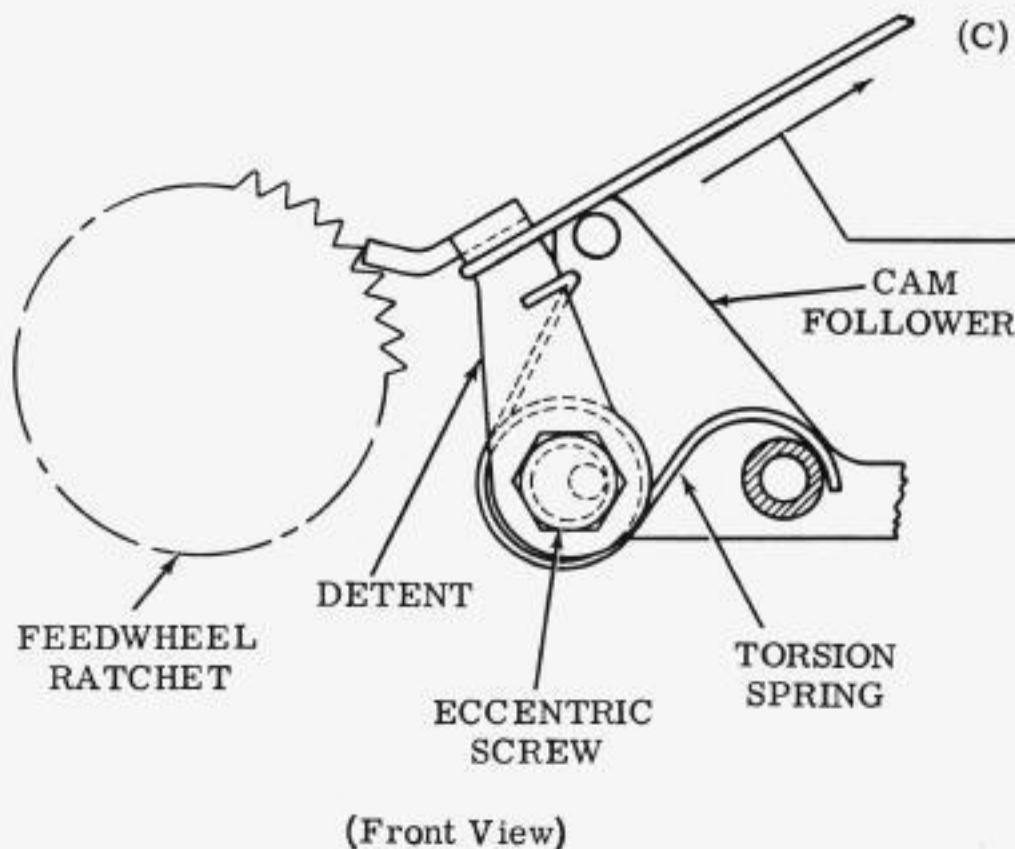

## 2.28 Ratchet Clutch Mechanism

(A) RATCHET CLUTCH ENDPLAY

## Requirement

With the ratchet clutch engaged, the feedwheel should be against the bushing and approximately centered in its slot in the guide plate. When checking the adjustment, the drum is to be seated against the bushing in the rear plate.

## To Adjust

With the top plate assembly removed, loosen the set screw in the shaft and position the bushing to centrally locate the set screw within the hole in the bushing (Preliminary Adjustment). Tighten the set screw. While viewing the unit from the solenoid end, loosen the screw in the drum and hold the drum against the bushing while taking up the play in the shaft to the right. Trip the ratchet clutch by pushing the top part of the lever with hub toward the clutch or by manually operating the eject solenoid plunger, (see illustration in EJECT SOLENOID STROKE adjustment) so that the ratchet teeth are fully engaged. While holding the drum against the bushing, ratchet teeth fully engaged, slide the shaft to the left until the (feedwheel) bushing contacts the feedwheel and the requirement is met. Tighten the drum screw. Check to see that the feedwheel is free to move laterally in its slot in the guide plate. Replace the top plate assembly.

Note: If, when moving the shaft to the left, the bushing cannot be made to contact the feedwheel, loosen the set screw and reposition the bushing toward the feedwheel to meet the requirement.

(B) RATCHET CLUTCH SPRING

## Requirement

With the scale applied to the clutch release

Min 2 oz---Max 4 oz

to keep the teeth of the two ratchets out of engagement.

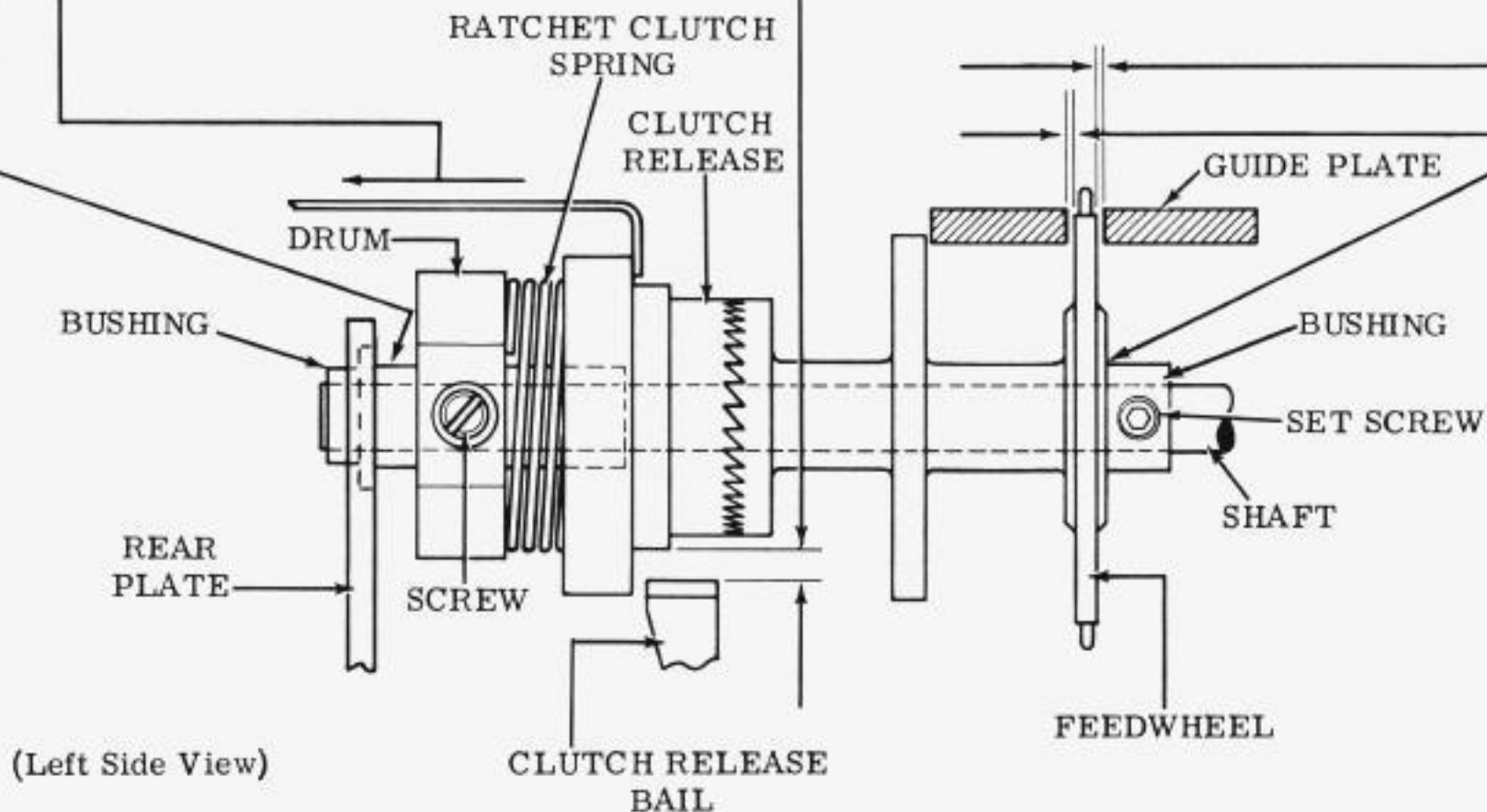

## 2.29 Lid Solenoid Mechanism

SOLENOID MOUNTING BRACKET

## Requirement

The solenoid mounting bracket should position both solenoids so that the plungers can operate freely through their required stroke and the lid will operate freely throughout its range.

## (1) To Adjust

With the solenoid mounting screws friction tight, the solenoid plunger should operate in the same plane as the solenoid levers. Do not tighten the solenoid mounting screws at this time.

## (2) To Adjust

With the solenoid bracket mounting screws friction tight, tip the bracket so that the lid will operate freely throughout its range. Tighten the solenoid mounting bracket screws.

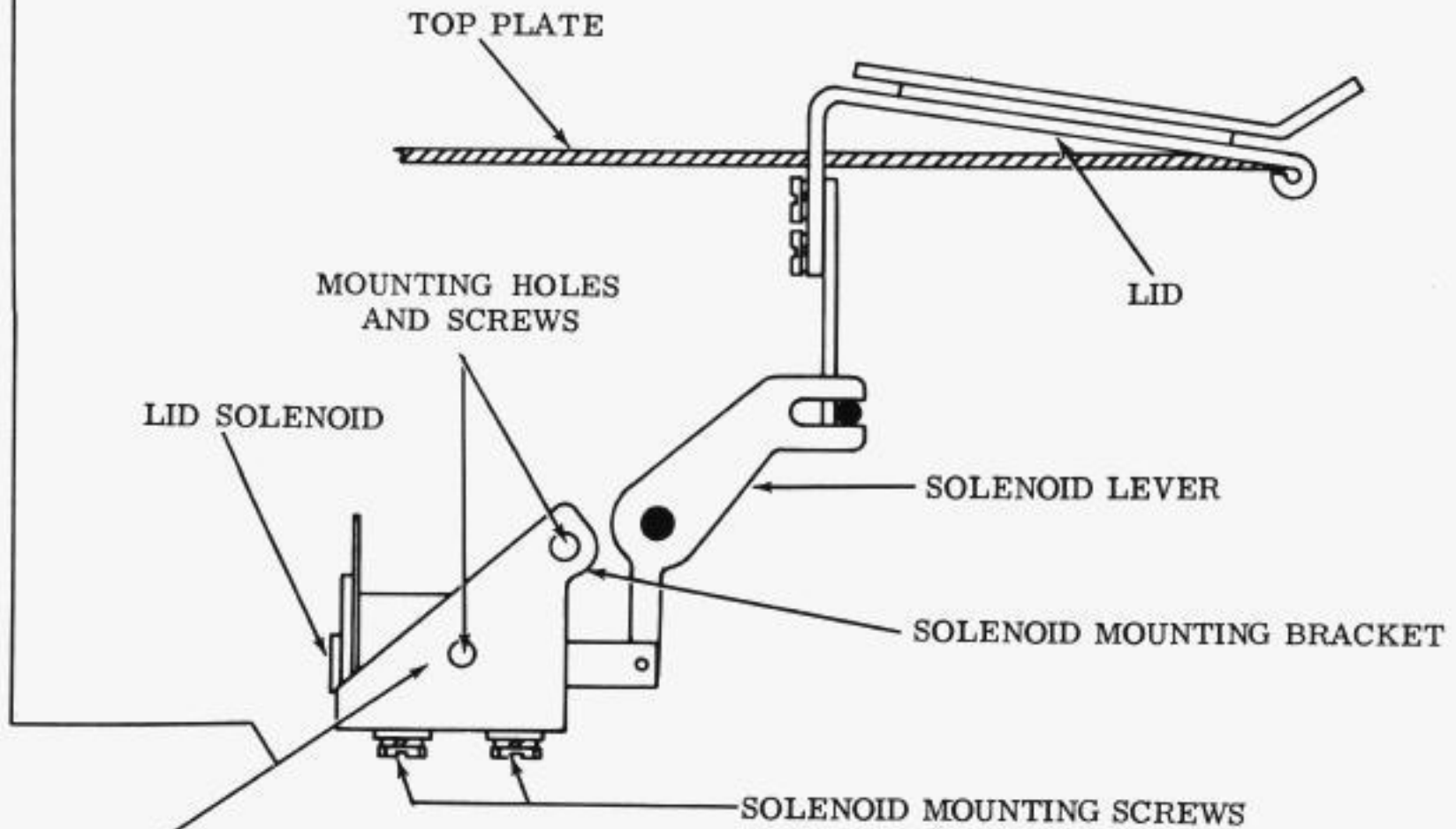

(Front View)

2.30 Lid Solenoid Mechanism (continued)

LID SOLENOID STROKE

Requirement

The lid solenoid must pull the lid tightly against its stop to prevent chatter.

(1) To Adjust

With the solenoid mounting screws friction tight and the plunger held to the left so that it bottoms in the solenoid, position the solenoid assembly to the left until the lid is seated down tightly. The plunger should move freely without any binds and all of the play in the linkages should be taken up. Tighten the solenoid mounting screws.

(2) To Adjust

This adjustment may be performed with the unit under power. Switch the unit into the tape mode to allow the lid solenoid to be energized. With the solenoid mounting screws friction tight, position the solenoid so that the lid is held down tightly. Tighten screws. Switch the unit to the card mode and check if the lid releases freely. Refine adjustment if necessary.

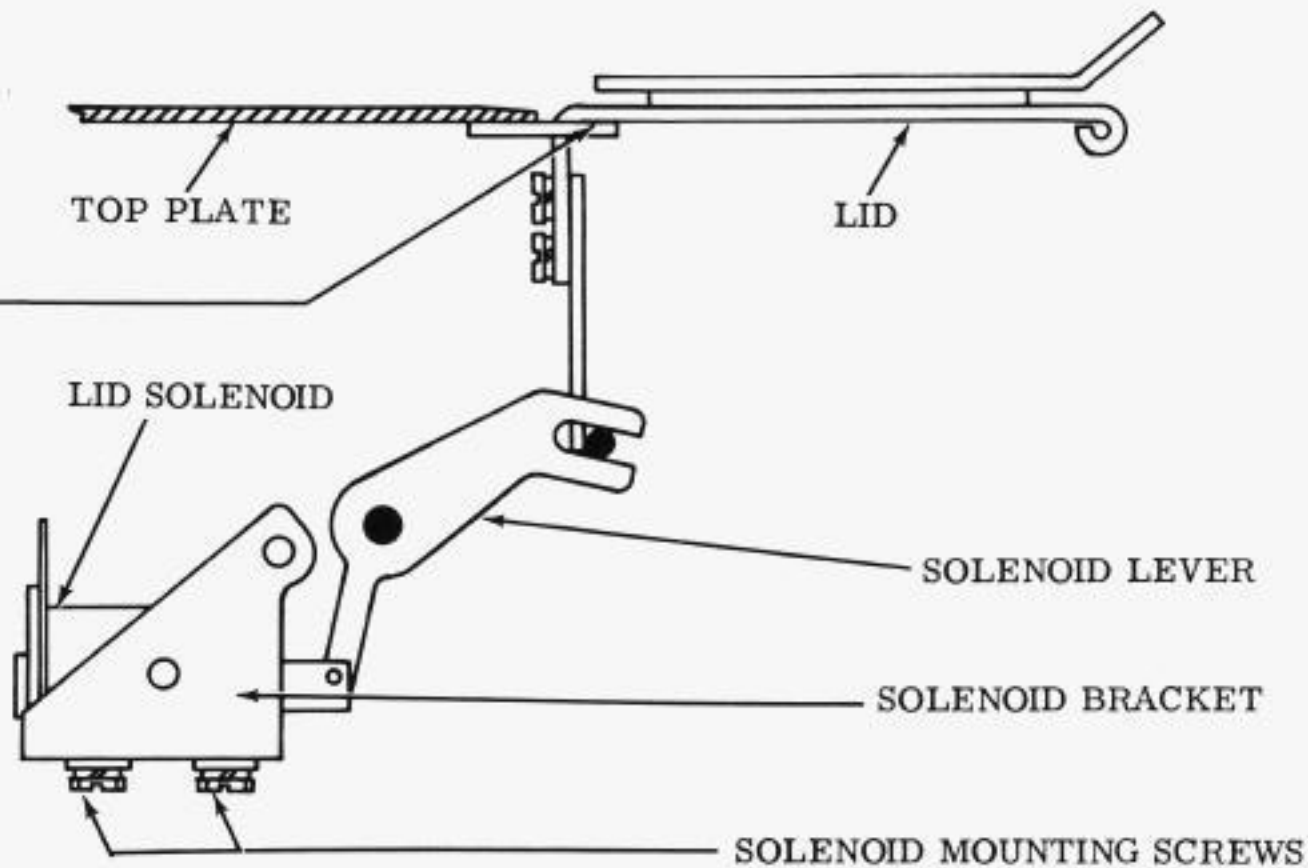

(Front View)



## 2.31 Eject Solenoid Mechanism

(A) EJECT SOLENOID STROKE

## Requirement

The plunger of the eject solenoid should move freely through its range in the de-energized position. The ratchet clutch bail must be free to be pulled to the lower surface of the clutch release to disengage the ratchet clutch. In its energized position the ratchet clutch bail must clear the outer diameter surface of the clutch release by

Min 0.015 inch---Max 0.030 inch

## To Adjust

With the nut of the eccentric friction tight rotate the eccentric to move the link to its lowermost position. Bottom the plunger in the solenoid and hold the plunger in this position. Move the solenoid along the slots in the bracket until clearance between the outer surface of the clutch release and the camming extension of the ratchet clutch bail meets the requirement. If the requirement cannot be met by moving the solenoid in its slots, leave solenoid in forward position in the slots in the mounting bracket and rotate the eccentric to meet the requirement. Tighten the solenoid mounting screws and the nut on the eccentric. The linkage should operate freely.

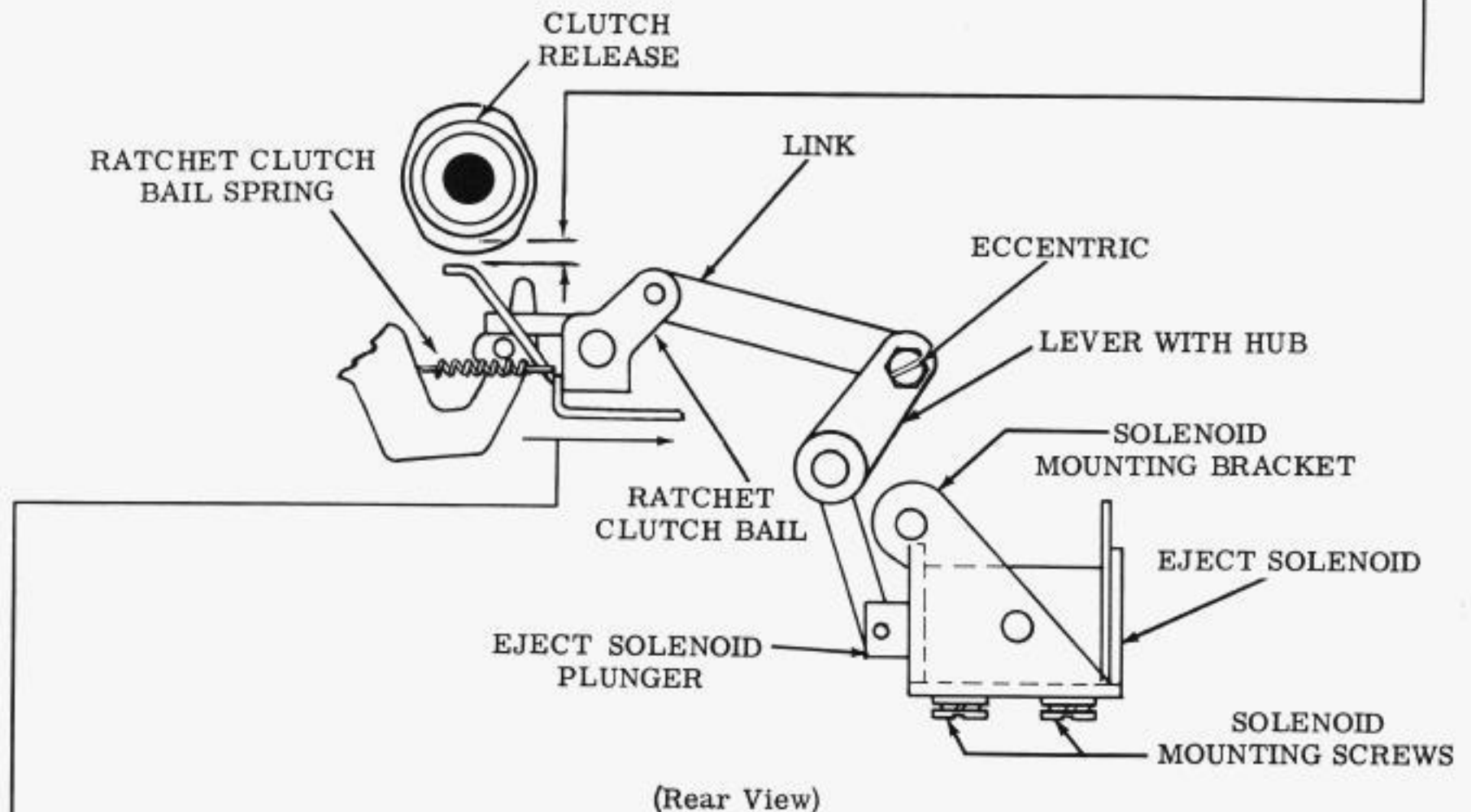
(B) RATCHET CLUTCH BAIL SPRING

## Requirement

Hold the clutch release so it does not bear against the ratchet clutch bail. With the pull end of the scale applied to the ratchet clutch bail next to the hole of the spring

Min 6 oz---Max 7-1/2 oz  
to start the bail moving.

2.32 Motor Gear Plate Assembly

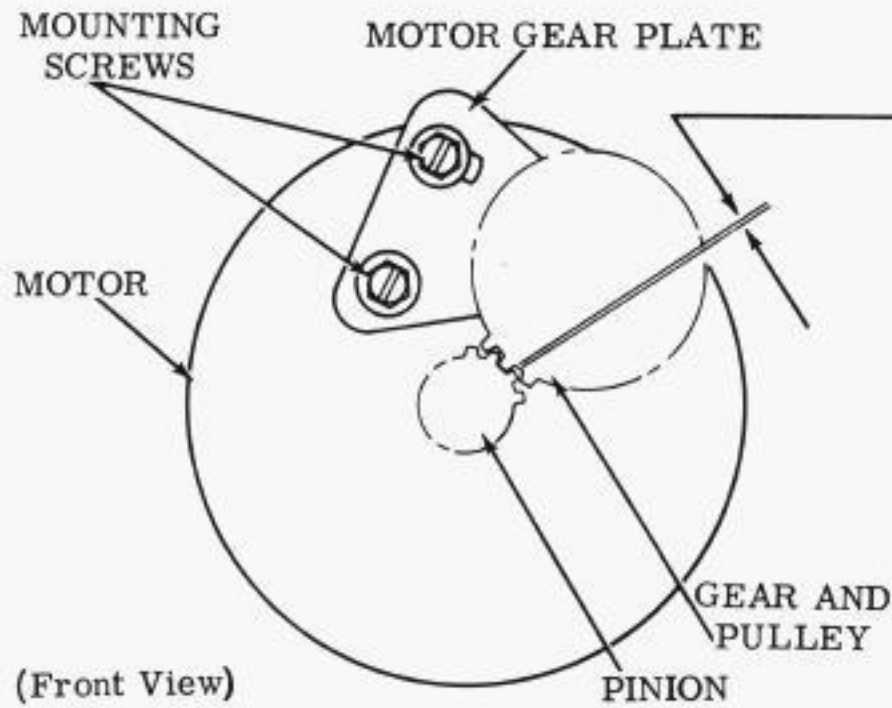

(Front View)

MOTOR GEAR BACKLASH

Requirement

There should be a barely perceptible amount of backlash between the gear and pinion at the point where the clearance between the gear and pinion is at a minimum.

To Adjust

With screws friction tight, position motor gear plate. Tighten screws.

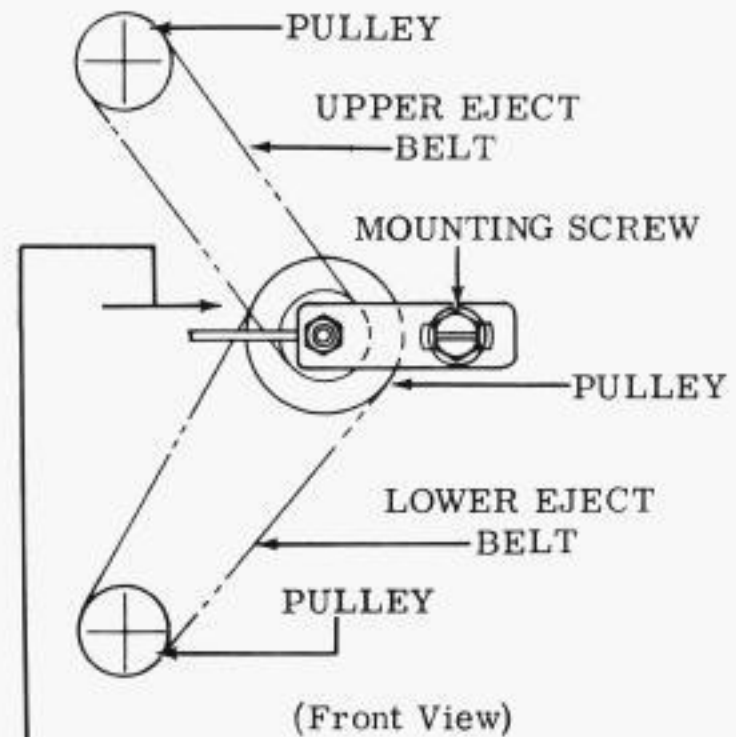

(Front View)

2.33 Pulley Mechanisms

(A) BELT TENSION

Requirement

A force of 16 ounces applied to the belt at the center between the pulleys should depress the belt

Min 0.190 inch---Max 0.235 inch

To Adjust

With the clampscrews friction tight, rotate the motor in its mounting bracket to obtain proper belt tension. Tighten screws and recheck tension.

(B) EJECT DRIVE BELT

Requirement

Min 16 oz---Max 20 oz

To Adjust

With mounting screw loose, to allow assembly to slide freely, apply push end of scale to the pulley assembly and push to the rear of the reader unit to meet the requirement. Tighten mounting screw to hold assembly in this position.

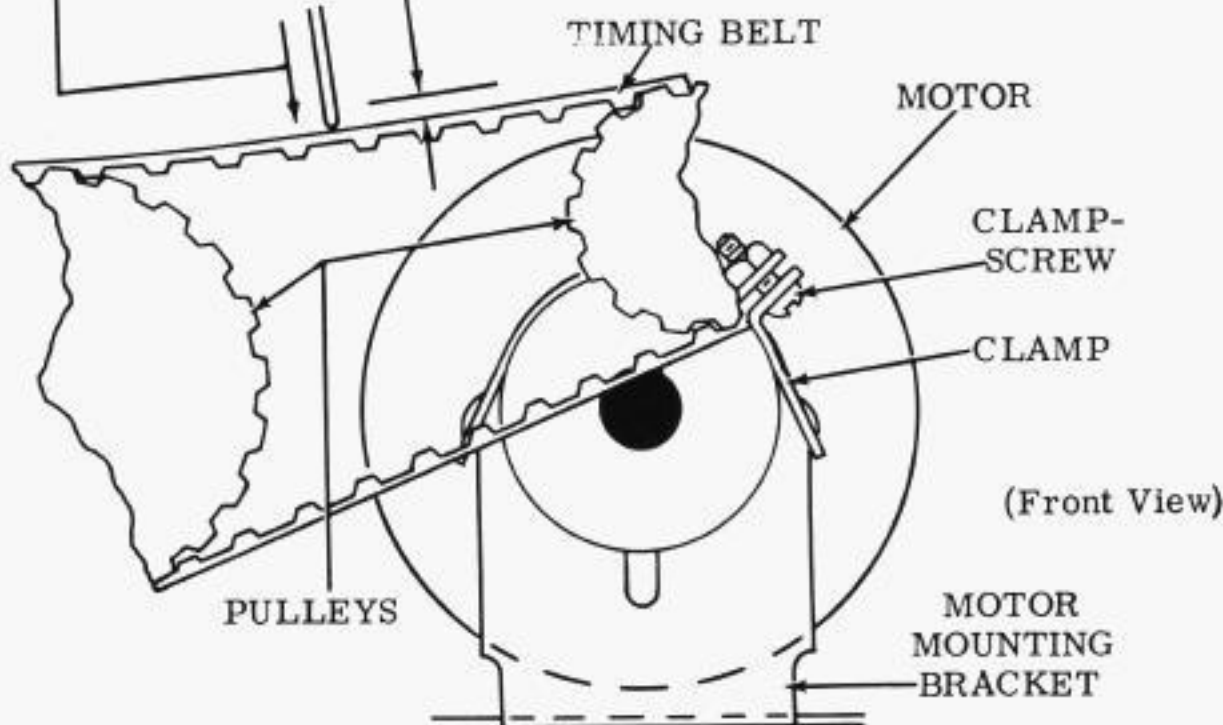

(Front View)

## 2.34 Fan Drive Mechanism

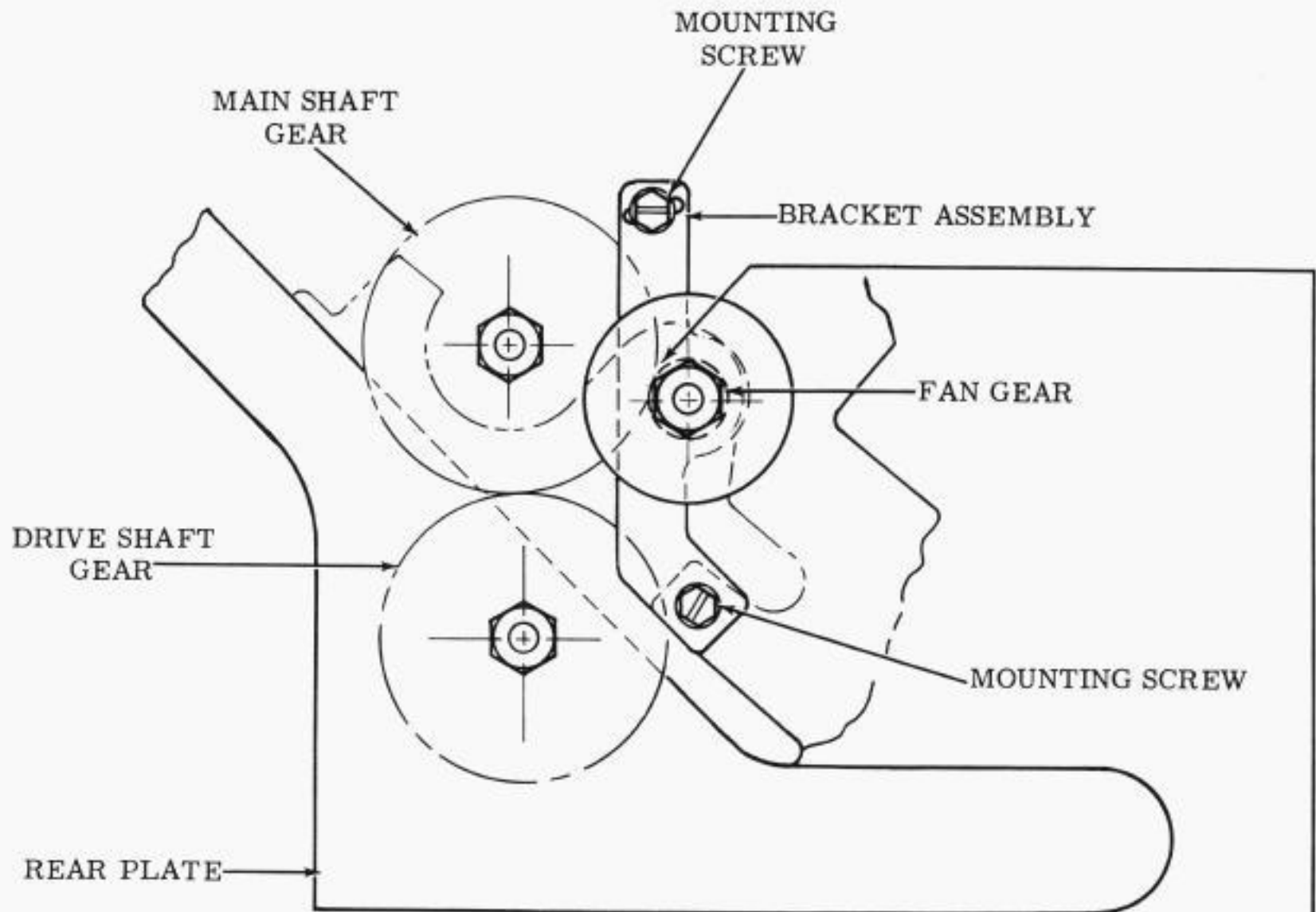

(Rear View)

GEAR BACKLASH FOR FAN DRIVE**Requirement**

There should be a barely perceptible amount of backlash between the fan gear and the main shaft gear.

**To Adjust**

Remove fan from bracket assembly. With the screws holding the bracket assembly friction tight, position bracket by means of the slot in the bracket. Tighten screws and replace fan.

Related Adjustment:

TRANSFER BAIL STABILIZER

2.35 Card-Out Mechanism (continued)

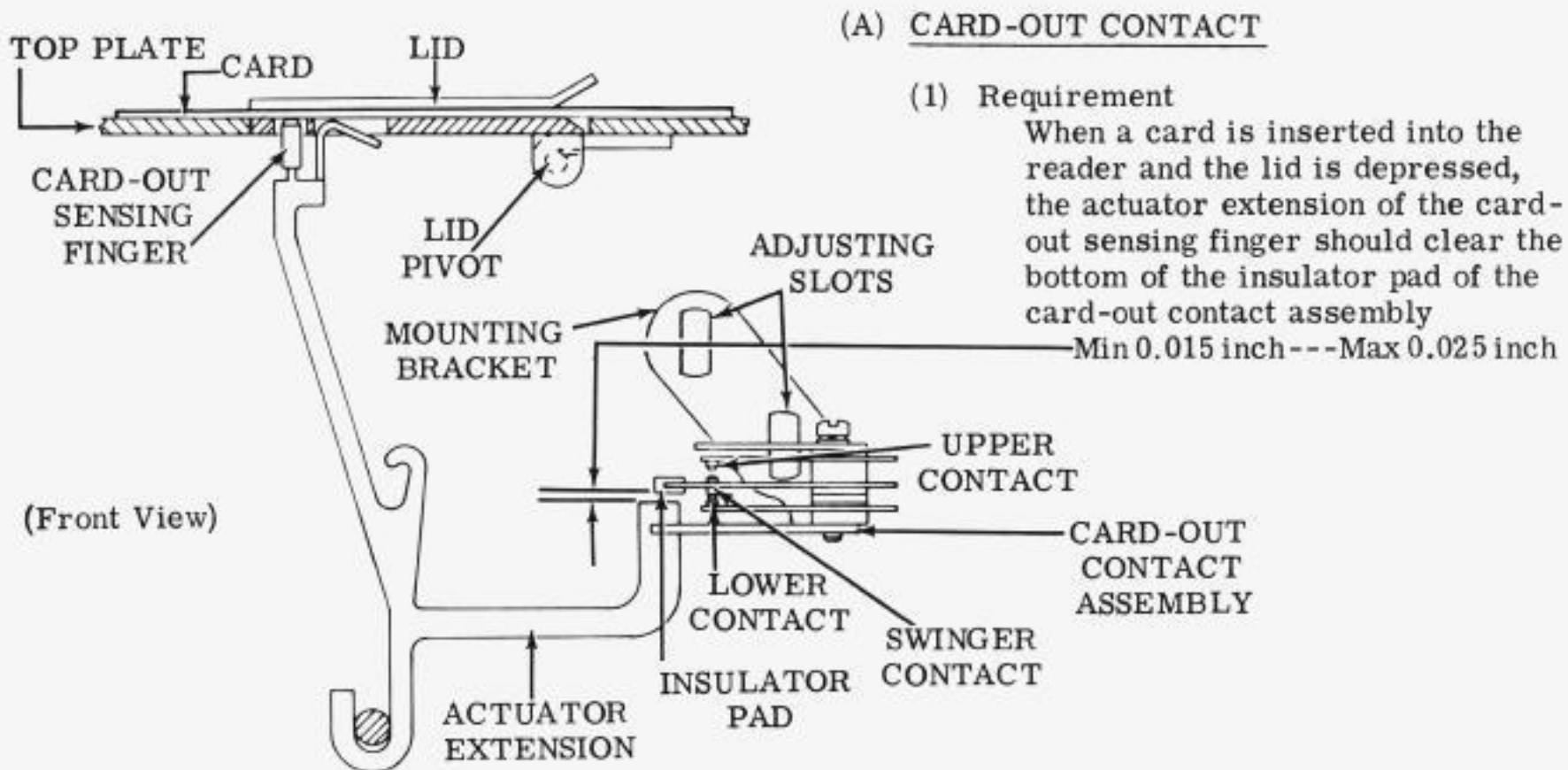

(2) Requirement

When the lid is released, the upper contact of the card-out contact assembly should close and the upper end of the card-out sensing finger should be below the surface of the open lid.

To Adjust

With the card-out contact mounting bracket mounting screws friction tight, position bracket by means of adjusting slots, to meet the requirements. Tighten bracket mounting screws.

(B) CARD-OUT CONTACT ACTUATING LEVER SPRING

Requirement

Min 1-3/4 oz --- Max 2-3/4 oz applied to the top of the pin to make the pin flush with depressed lid.

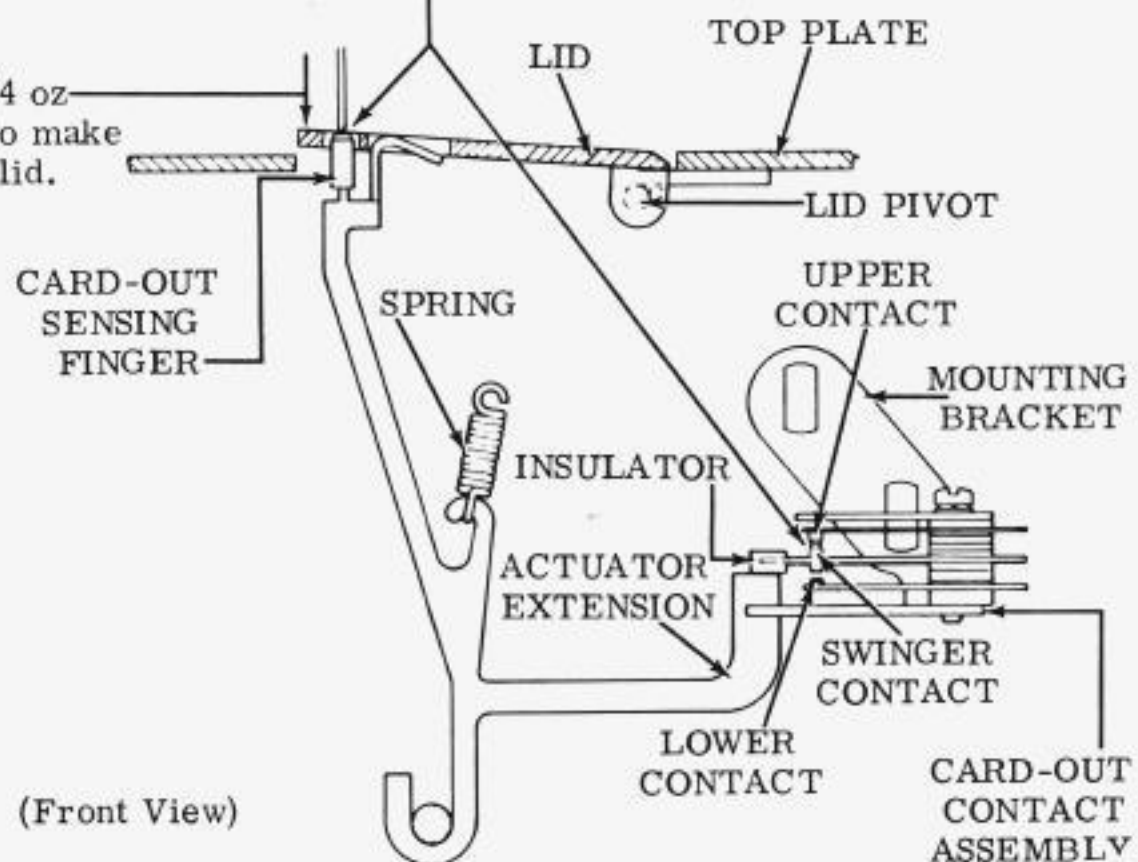



## 2.36 Card-In Contact Mechanism

(B) CARD-IN CONTACT ACTUATING LEVER SPRING

## Requirement

With the lid held down,

Min 1/4 oz---Max 1-1/4 oz

applied to the tip of the lever to move the lever to a flush position with the lid.

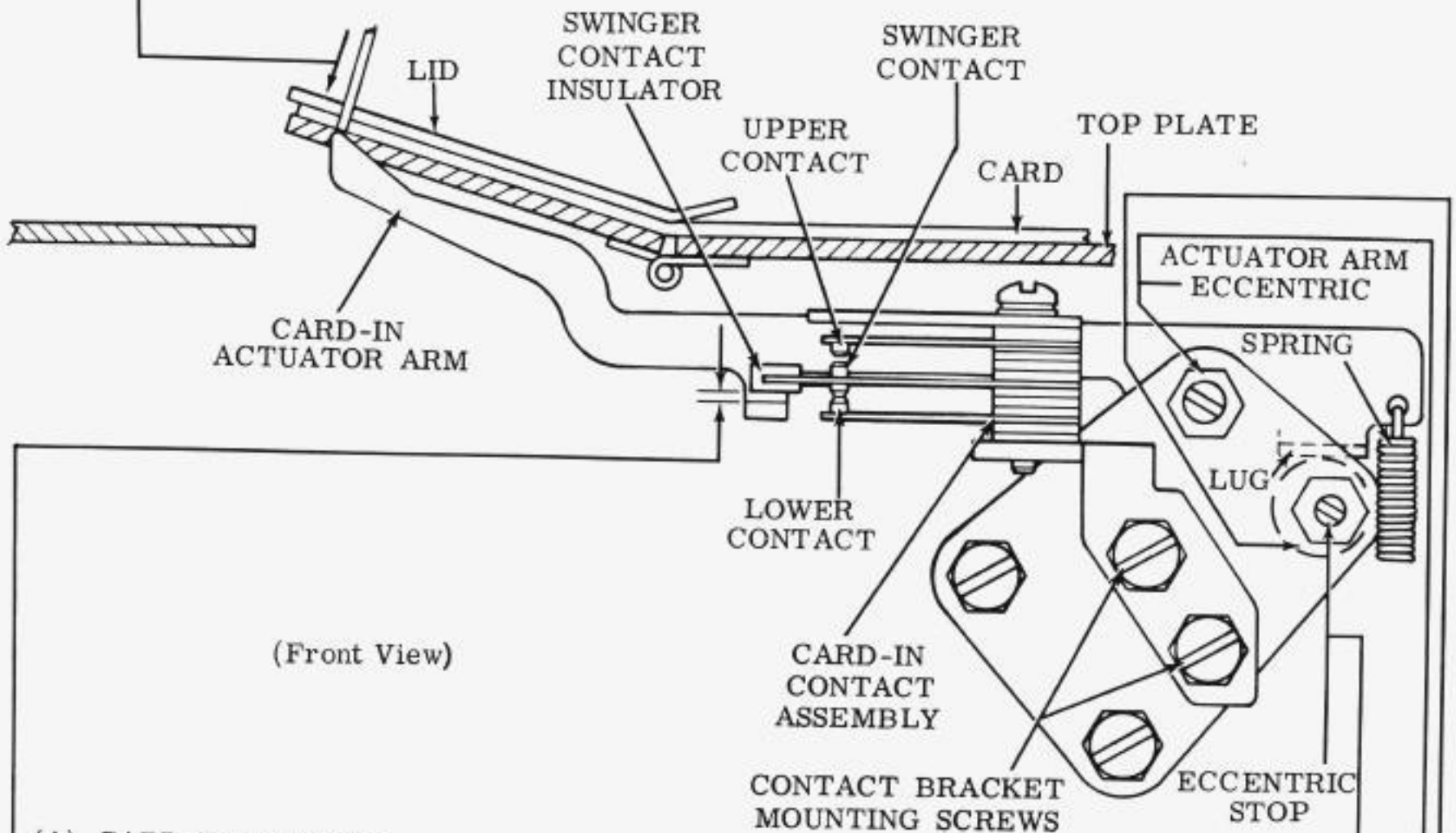

(Front View)

(A) CARD-IN CONTACT

## (1) Requirement

In the idle condition with no card inserted, the upper contact of the card-in contact assembly should be closed by the actuator arm.

## (2) Requirement

A card inserted into the reader should open the upper and close the lower contact. Clearance between the card-in actuator arm and the swinger contact insulator of the card-in contact

Min 0.010 inch

## (1) To Adjust

With the nut of the eccentric stop friction tight, rotate the eccentric stop to its lowest position.

## (2) To Adjust

With the nut of the actuator arm eccentric friction tight, rotate the eccentric to its lower left-hand quarter. Tighten nut.

## (3) To Adjust

With the two mounting screws of the contact bracket friction tight, position bracket to meet Requirement (2).

## (4) To Adjust

With no card in the reader, rotate the eccentric stop up until the eccentric barely touches the lug at the pivot end of the card-in actuator arm. Tighten nut on eccentric stop. Recheck to see that Requirement (1) has been met.

2.37 Eject Actuator Contact Assembly (continued)

(A) EJECT CONTACT ACTUATOR

(1) Requirement

With the unit in its idle position, the upper contacts of the eject contact assembly should be closed and the lower contacts should be open.

(2) Requirement

With a card positioned above the contact lever, the lever should be depressed so that its actuator extension opens the upper contact and closes the lower contact. There should be some clearance between the insulator of the swinger contact spring and the actuator arm of the lever.

To Adjust

Refine EJECT ACTUATOR — PRELIMINARY adjustment as follows:

With the contact assembly mounting screw and spring post friction tight, position the switch bracket. Tighten the screw and spring post.

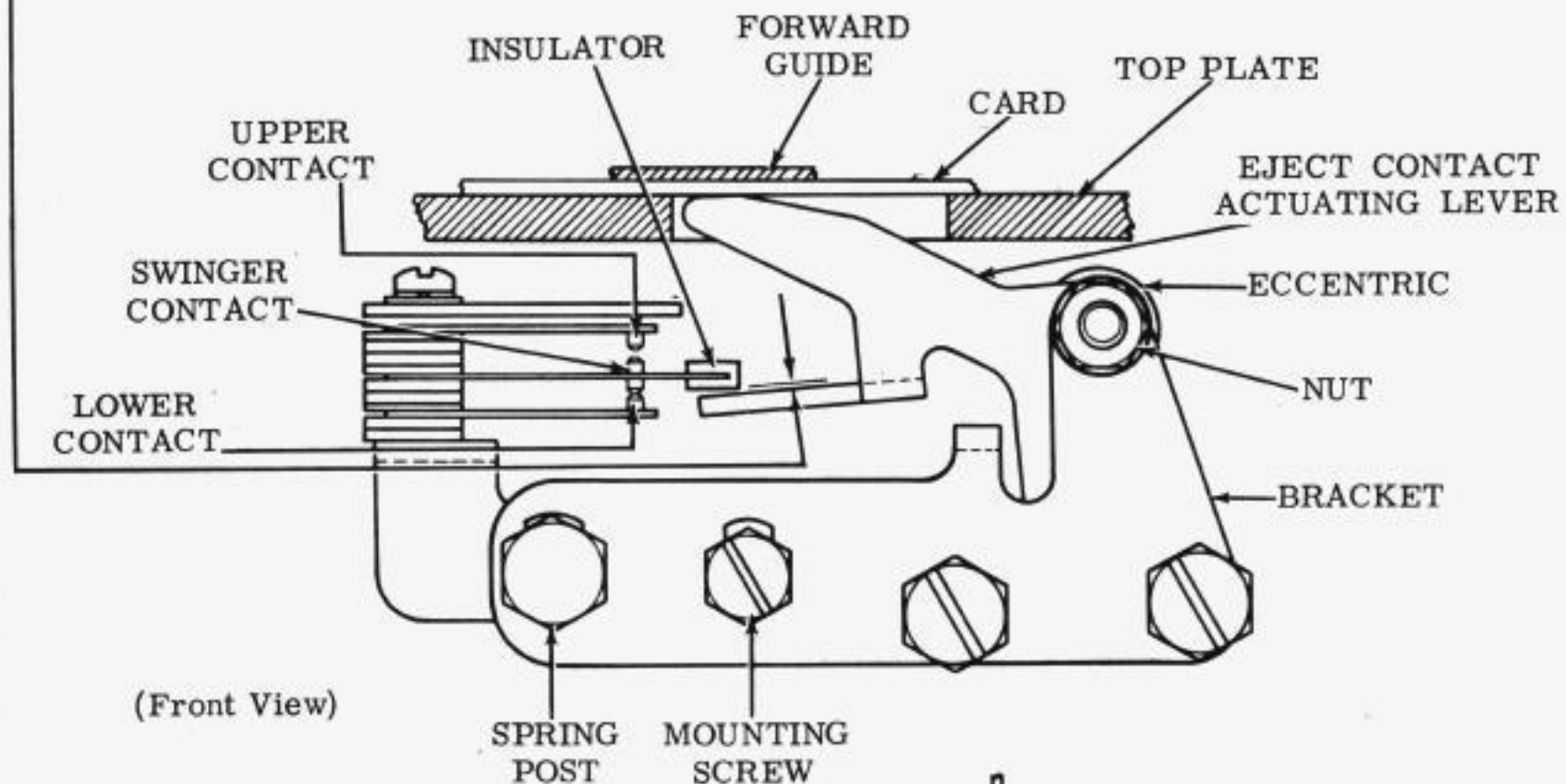

(Front View)

(B) EJECT CONTACT ACTUATING LEVER SPRING

Requirement

Min 1/2 oz --- Max 1-1/2 oz applied to the top of the actuating lever to a position flush with the top plate.

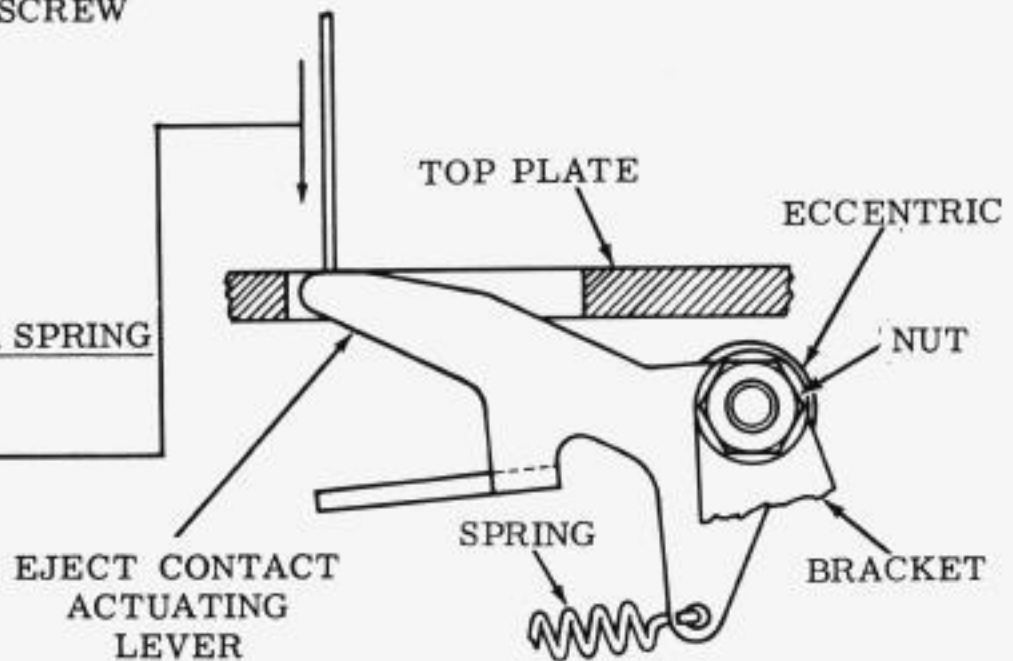

(Front View)

## 2.38 Signal Contact Assembly

(A) SIGNAL CONTACT

Note 1: Remove the contact box cover.

Requirement

The marking and spacing contact gaps should be equal when there is maximum clearance between the contacts as determined by engaging the clutch and rotating the main shaft.

To Adjust

With the contact box bracket mounting screws friction tight, position the box by means of the eccentric. Tighten the screws and recheck the adjustment.

Note 2: Where possible, use a signal checking device to refine this adjustment. Refine the TRANSFER BAIL STABILIZER adjustment if necessary.

Note 3: Refer to Paragraphs 1.09 to 1.14 for information on gold-plated contacts.

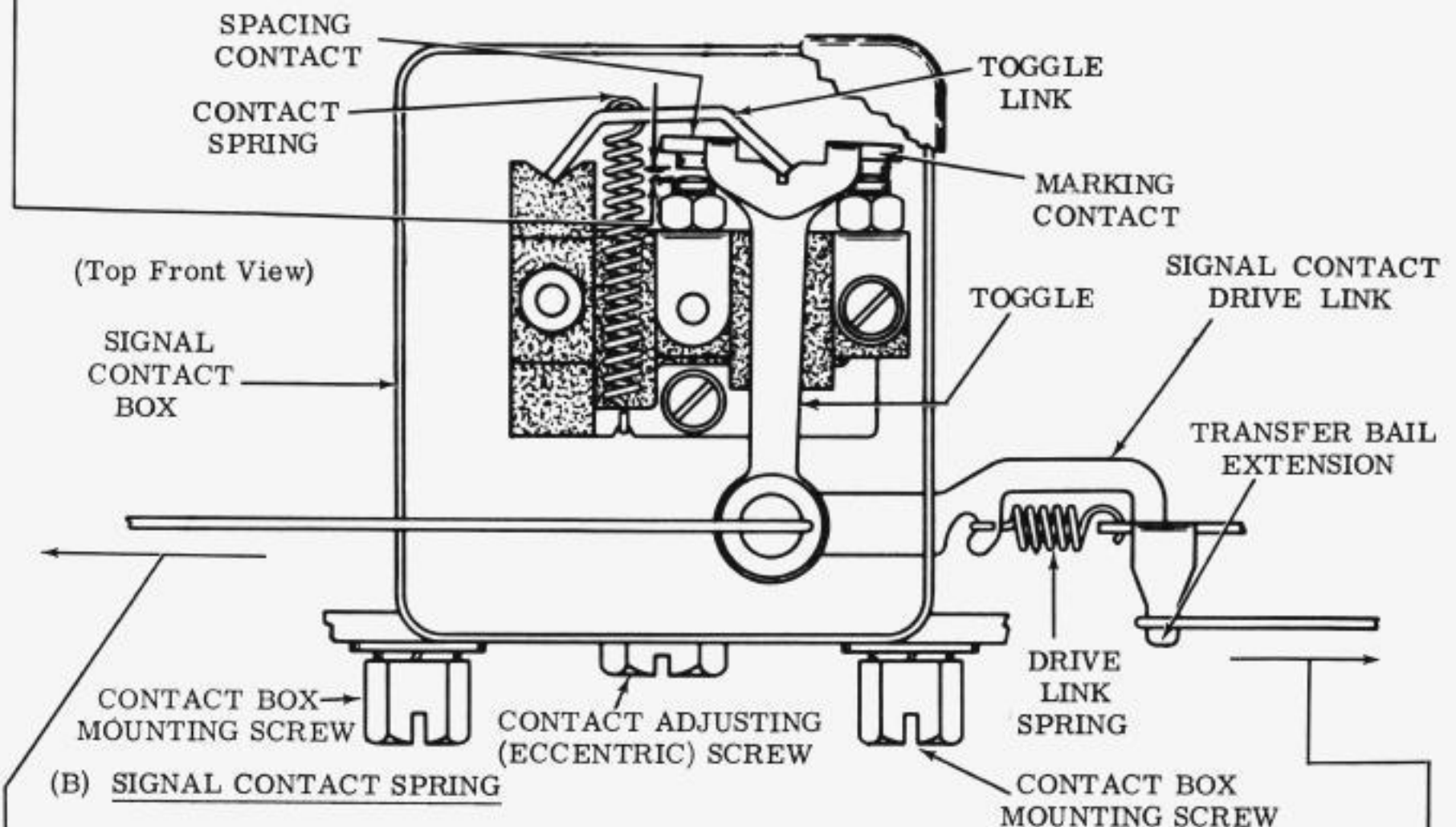
(B) SIGNAL CONTACT SPRINGRequirement

With the transmitter in the stop position, unhook the drive link spring from the link. Move the transfer bail to its right-hand (spacing) position so that both toggle contacts are closed. Hook the scale over the pivot screw and pull horizontally to the left

Min 2 oz --- Max 3-1/2 oz

to open the left-hand spacing contact. Replace the drive link spring.

(C) SIGNAL CONTACT DRIVE LINK SPRINGRequirement

With the transmitter in the stop position, unhook the stabilizer spring and position the latches away from the transfer bail extension. Hold the contact toggle firmly against the contacts.

Min 6 oz --- Max 9 oz

to start transfer bail extension moving. Replace the stabilizer spring and the contact box cover.



## 2.39 Signal Contact Assembly (continued)

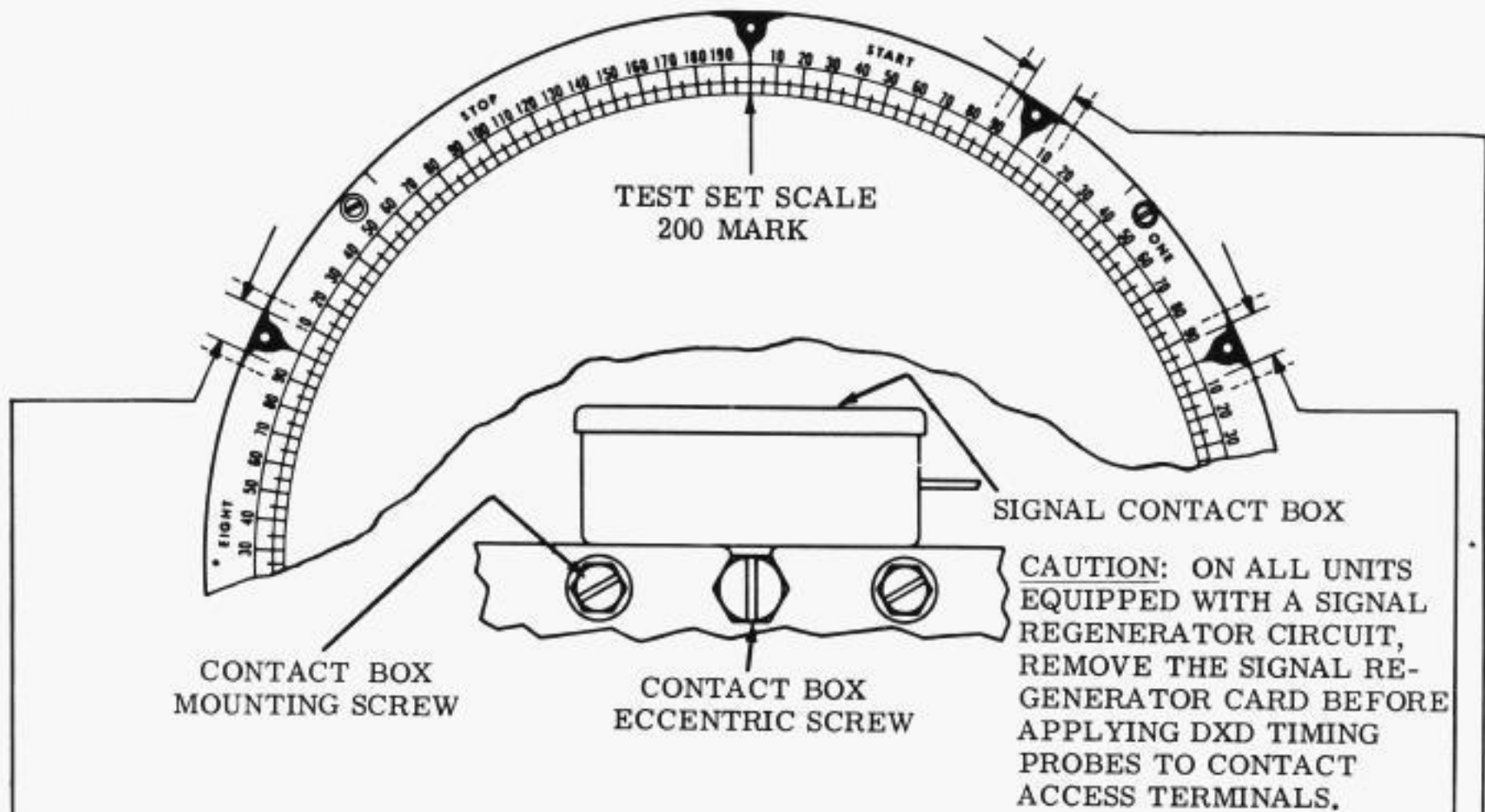

SIGNAL PULSE REFINEMENT — FINAL ADJUSTMENT WITH DXD OR STROBE (when available) (11.00 Unit Code - Speeds up to and including 100 wpm) (See Note 4, Par. 2.40)

**Procedure**

Plug signal distortion test set into signal line to view pulse image generated by the marking and spacing contacts. Synchronize signal generator with DXD so that end of stop pulse image aligns with the 200 mark on DXD scale when both units are operated at same speed and transmission is continuous.

Note 1: Figures appearing in ( ) in Par. 2.39 and 2.40 are relaxed requirements for the reader sets used in circuits that employ a signal regenerator.

Note 2: End of stop pulse image should not vary from the 200 mark by more than one scale division. If a greater variation occurs, move the scale until the variations extend equally on either side of the 200 mark.

(1) Requirement

- (a) Each marking code pulse should start no later than the 8th (12th) mark of the pulse under observation and start no earlier than 92nd (88th) mark of the previous pulse.
- (b) Each marking code pulse should end no earlier than the 92nd (88th) mark of the pulse under observation and no later than the 8th (12th) mark of the following pulse.
- (c) Each marking code pulse may have one break provided the break is not over three divisions wide and provided the break occurs only at the end of the code pulse image between the 92nd (88th) mark and the end of the image.
- (d) The stop pulse should start no earlier than the 92nd (88th) mark of the last intelligence pulse and start no later than the 8th (12th) mark of the stop position.



## 2.40 Signal Contact Assembly (continued)

SIGNAL PULSE REFINEMENT — FINAL ADJUSTMENT WITH DXD OR STROBE (continued)  
(11.00 Unit Code - Speeds up to and including 100 wpm)

- (e) The stop image should not change in length or position, when viewed on DXD, to exceed one division while changing from R to Y selection (or equivalent codes). If necessary, reorient 200 mark on stop scale with end of stop pulse image.

## To Adjust

With signal contact box mounting screws friction tight, rotate the eccentric (right or left). Tighten mounting screws and recheck adjustment.

## (2) Requirement

When the spacing contact of the signal generator is wired the spacing contact should meet the following requirements:

- (a) Each spacing code pulse should start no later than the 8th (12th) mark of the pulse under observation and start no earlier than the 92nd (88th) mark of the previous pulse.
- (b) Each spacing pulse should end no earlier than the 92nd (88th) mark of the pulse under observation and end no later than the 8th (12th) mark of the following pulse.
- (c) Each spacing pulse may have one break provided the break is not over three divisions wide and provided the break occurs only at the end of the code pulse image between the 92nd (88th) mark and the end of the image.
- (d) The start pulse should start no earlier than the 192nd (188th) mark of the stop pulse and start no later than the 8th (12th) mark of the start pulse. The start pulse should end no earlier than the 92nd (88th) mark of the start pulse and end no later than the 8th (12th) mark of the number one pulse.

## To Adjust

Same as above - Recheck marking contact if a spacing adjustment is made.

Note 3: If the signal requirements cannot be met, refine GEAR BACKLASH FOR FAN DRIVE and TRANSFER BAIL STABILIZER adjustment with signal viewed on DXD.

Note 4: Refer to Paragraphs 1.09 to 1.14 for information on gold-plated contacts.

CAUTION: BEFORE MAKING THE CODE READING CONTACT ADJUSTMENTS, REMOVE SOLENOID MOUNTING BRACKET (4) SCREWS. REMOVE CONTACT BOX. IF SOLENOID MOUNTING BRACKET IS NOT REMOVED BEFORE CONTACT BOX, DAMAGE TO CODE READING CONTACTS CAN OCCUR.

2.41 Code Reading Contacts

Initial Adjustment

Note: Initial adjustments should be made with the code reading contact assembly removed from the reader unit.

NORMALLY CLOSED CONTACTS — BACKSTOP

Requirement

The lower contact leaves for all levels should be parallel to the mounting plate and in line with one another as gauged by eye.

To Adjust

Bend backstop to meet requirement.

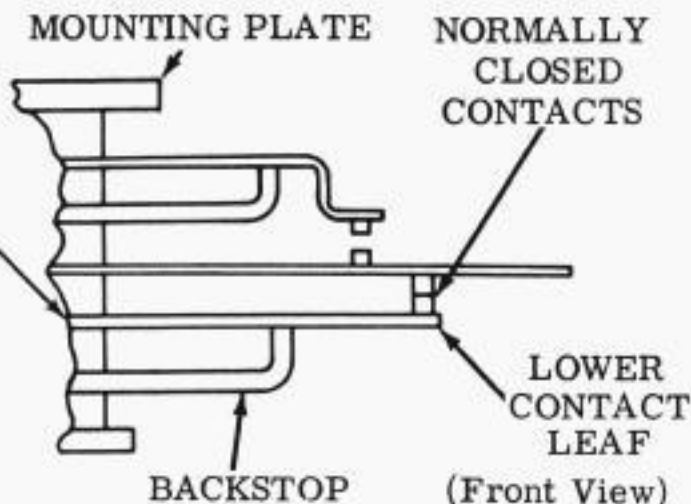

NORMALLY CLOSED CONTACTS — SPRING

(1) Requirement

With swinger held away  
Min 2 oz --- Max 6 oz  
to move lower contact leaf away from backstop.

To Adjust

Bend lower leaf. If it is necessary to bend backstop to obtain required tension, reposition backstop to meet NORMALLY CLOSED CONTACTS — BACKSTOP requirement.

(2) Requirement

Min 30 grams --- Max 40 grams  
to open normally closed contacts.

To Adjust

Bend swinger.

NORMALLY OPEN CONTACTS — GAP

Requirement

Min 0.010 inch --- Max 0.015 inch  
gap between normally open contacts.

To Adjust

Bend associated backstop to meet requirement.

NORMALLY OPEN CONTACTS — SPRING

Requirement

Min 30 grams --- Max 40 grams  
to move normally open contact away from backstop.

To Adjust

Bend upper contact leaf. If it is necessary to bend backstop to obtain required tension, reposition backstop to meet NORMALLY OPEN CONTACTS — GAP requirement.

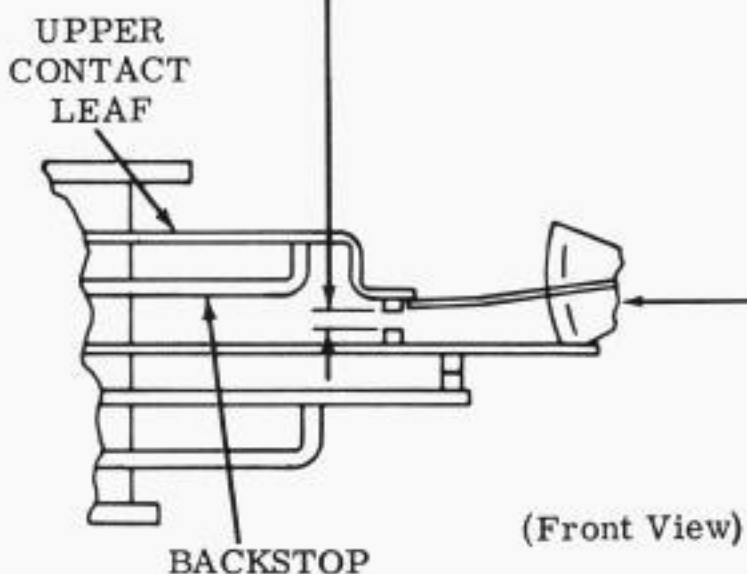
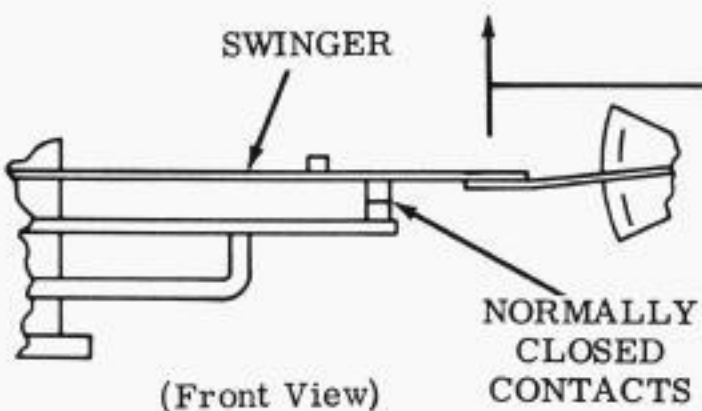
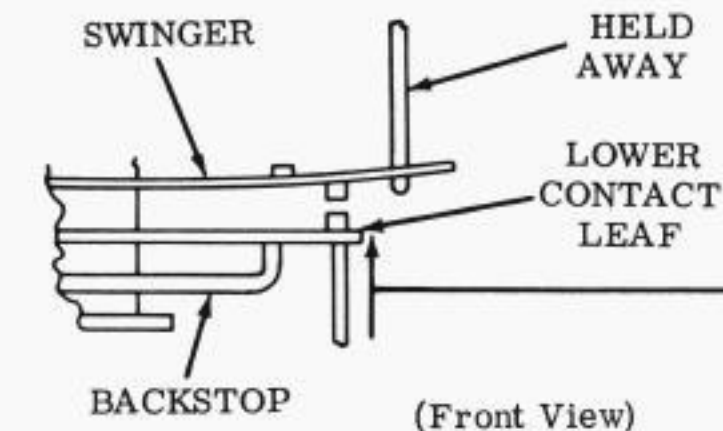

2.42 Code Reading Contacts (continued)

Secondary Adjustments (continued)

(C) SENSING ARM SPRING

Requirement

With clutch disengaged  
 Min 2-1/2 oz---Max 3-1/2 oz  
 to start sensing arm moving.

(A) SENSING ARM — TRANSFER LEVER  
 ALIGNMENT

Requirement

With the BLANK combination selected  
 and the clutch tripped, the sensing arms  
 must engage their respective transfer  
 levers by a

Min 2/3 of their thickness.

To Adjust

Add shims as required between the  
 plate assembly and the split bail spacer.  
 Store the remaining shims under flat  
 washer at the end of the split bail  
 eccentric.

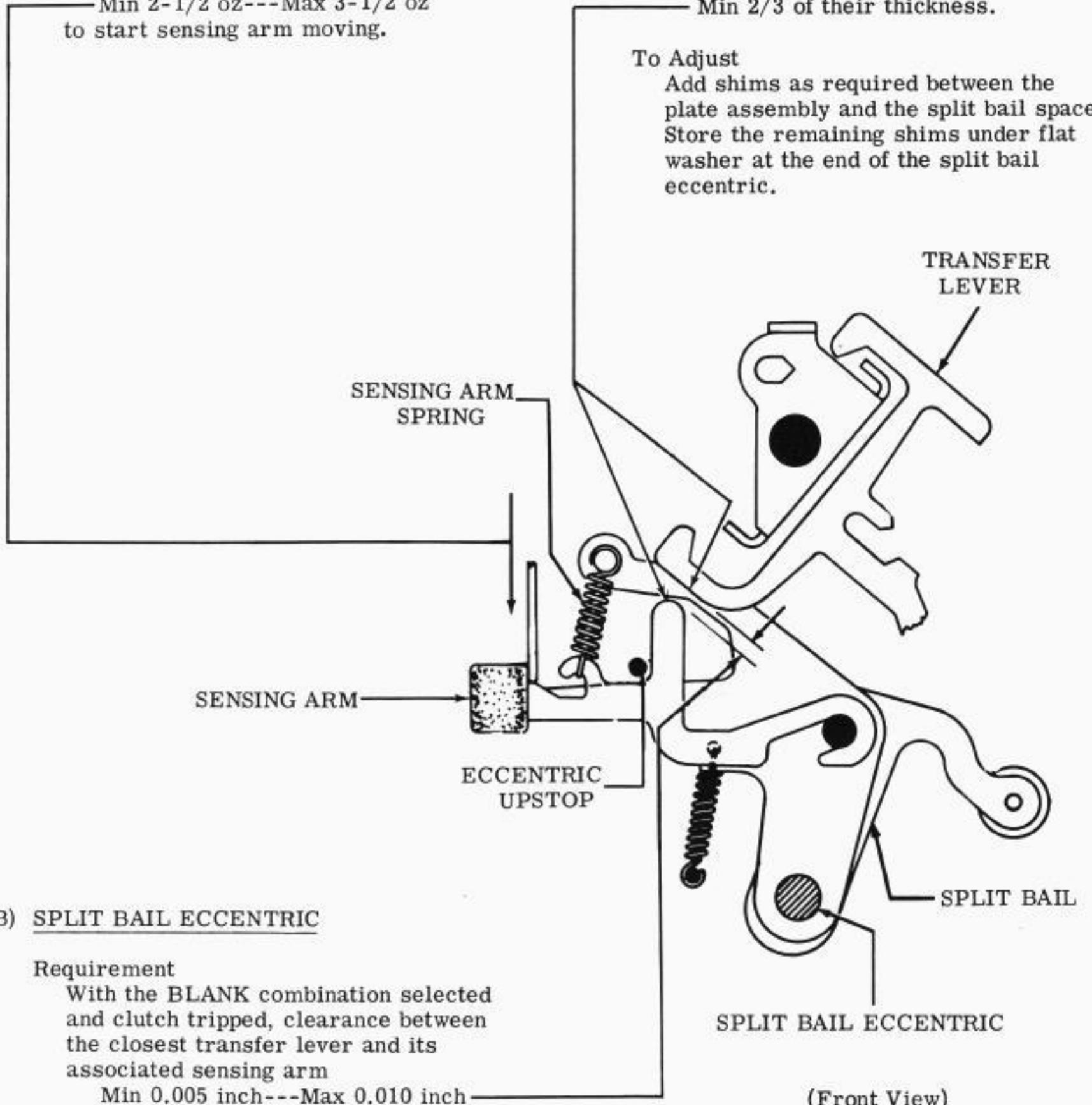

(B) SPLIT BAIL ECCENTRIC

Requirement

With the BLANK combination selected  
 and clutch tripped, clearance between  
 the closest transfer lever and its  
 associated sensing arm

Min 0.005 inch---Max 0.010 inch

To Adjust

Rotate the split bail eccentric with its lock  
 nut loosened. The drive shaft should be  
 removed to gain access to the nut.  
 Tighten lock nut and replace drive shaft.

(Front View)

2.43 Code Reading Contacts (continued)

Secondary Adjustments

Note: The secondary adjustments should be made with the code reading contact assembly installed in the reader and with the contact assembly bracket approximately centered in its adjustment range (remove the contact box to facilitate adjustment).

CONTACT ASSEMBLY ALIGNMENT

Requirement

The swinger of each contact assembly should be aligned with its associated sensing arm as gauged by eye.

To Adjust

Loosen the screws which mount the contact assembly to the contact bracket and position the assembly to meet requirement. Tighten screws.

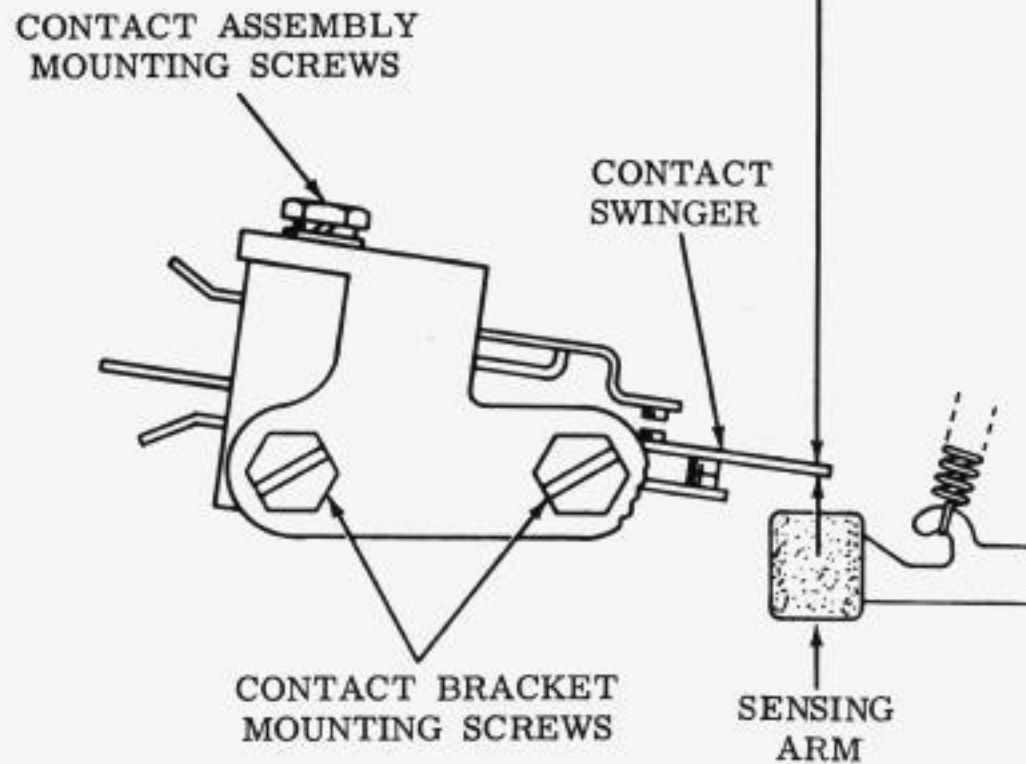

(Front View)



2.44 Code Reading Contacts (continued)

Secondary Adjustments (continued)

CONTACT ASSEMBLY POSITION — PRELIMINARY

Requirement

With the BLANK combination selected, the up-stop post out of the way, and the sensing arms in their uppermost position

Min 0.015 --- Max 0.025 inch  
gap between contact assembly swingers and insulator on contact sensing arm.

To Adjust

Loosen the contact bracket mounting screws and position the bracket to meet requirements. Tighten screws.

Related Adjustment:

CONTACT SWINGER - SENSING ARM CLEARANCE

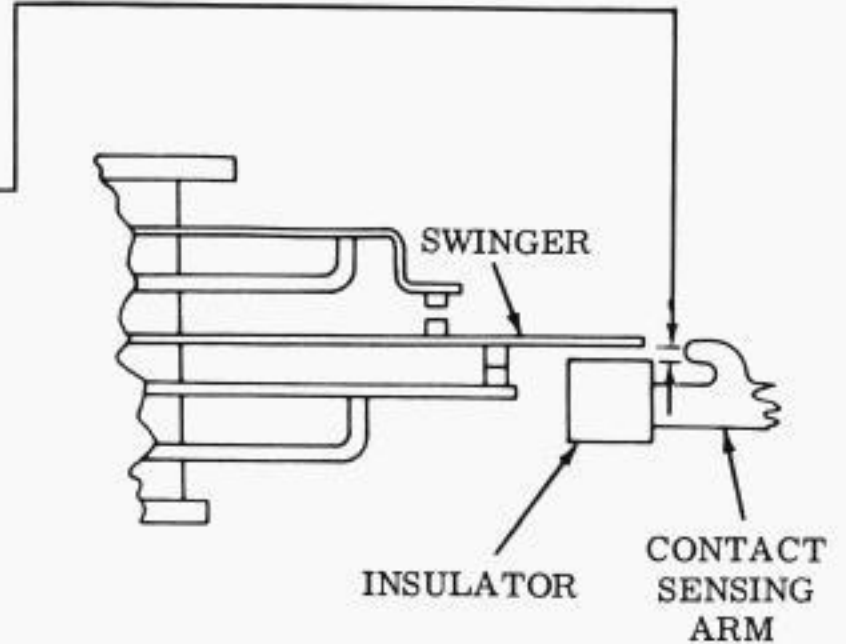

(Front View)

CONTACT SENSING ARM, UP-STOP ADJUSTMENT

Requirement

With LETTERS combination selected, clutch engaged, and main shaft rotated until the sensing arms are in their uppermost position, there should be

Min Some --- Max 0.008 inch  
clearance between the upper contact leaf and its backstop.

To Adjust

Loosen the nut that secures the eccentric up-stop to the front plate and turn the eccentric until the requirement is satisfied. The high part of the eccentric should be toward the left. Tighten nut.

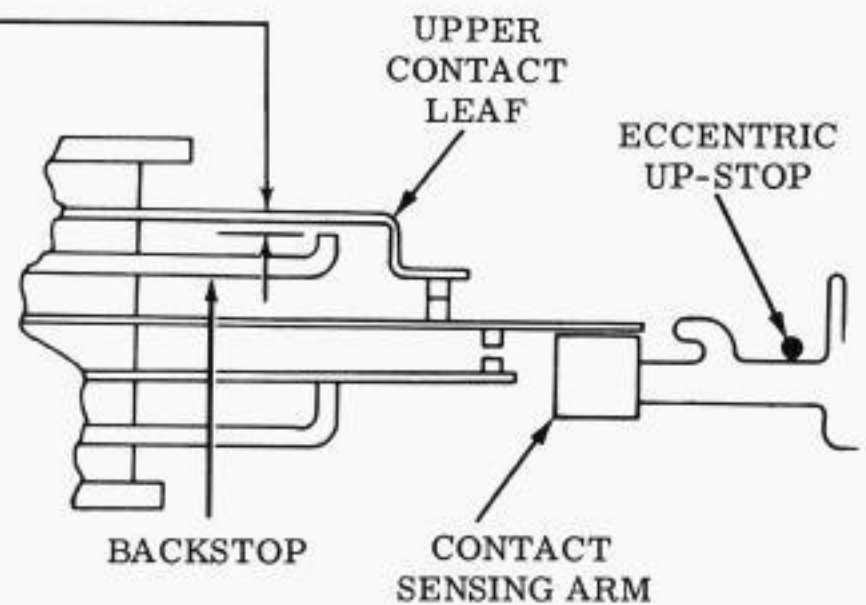

(Front View)

## 2.45 Code Reading Contacts (continued)

## Final Adjustments (Strobing)

CONTACT SWINGER — SENSING ARM CLEARANCE

Note 1: When strobing the code reading contacts, use a DXD scale (when available) whose unit code corresponds to that of the unit being checked. See CONTACT OPERATING REQUIREMENTS TABLE. The signal generator on the reader should be synchronized with the DXD so that the end of the stop pulse image is in line with the end of the stop pulse on the DXD scale when transmission is continuous. Normal signal line current of 60 ma +10 percent or 20 ma +10 percent should be used to strobe the contacts. Current applied to these contacts is dc.

## (1) Requirement

The contacts should open and close within the range specified on the CONTACT OPERATING REQUIREMENTS TABLE.

## (2) Requirement

Breaks in the marking pulses should be confined to the first and last 10 divisions of the trace. The spacing pulses should be full scale with no breaks.

## To Adjust

Refine CONTACT ASSEMBLY POSITION — PRELIMINARY as follows:

Loosen contact assembly bracket mounting screws and position contact assembly to meet requirements. Tighten screws.

CONTACT OPERATING REQUIREMENTS TABLE

LEVELS	UNIT CODE	START OF PULSE			END OF PULSE			MAX PULSE LENGTH OSC (DIV)
		SCALE SEGMENT	SCALE DIVISIONS	TOLERANCE (DIV)	SCALE SEGMENT	SCALE DIVISIONS	TOLERANCE (DIV)	
8	11.00	PULSE 1	95	+30	PULSE 8	5	+30	5

Note 2: After the adjustment has been made, check clearance between the contact swinger and the insulator on the contact sensing arm when the BLANK combination has been selected and the main shaft has been rotated to place the sensing arms in their maximum upward travel. There should be some clearance. If the requirement cannot be met, recheck NORMALLY CLOSED CONTACTS — SPRING adjustment.

2.46 Auxiliary Contacts

Initial Adjustments

Note: The initial adjustments should be made with the auxiliary contacts removed from the reader unit.

NORMALLY OPEN CONTACTS

(1) Requirement  
 Min 5-1/2 oz --- Max 6 oz  
 to move normally open contact away from stiffener.

To Adjust  
 Bend the normally open contact leaf to meet requirement.

(2) Requirement  
 Min 0.015 inch --- Max 0.020 inch  
 gap between normally open contacts.

To Adjust  
 Bend the contact stiffener to meet requirement.

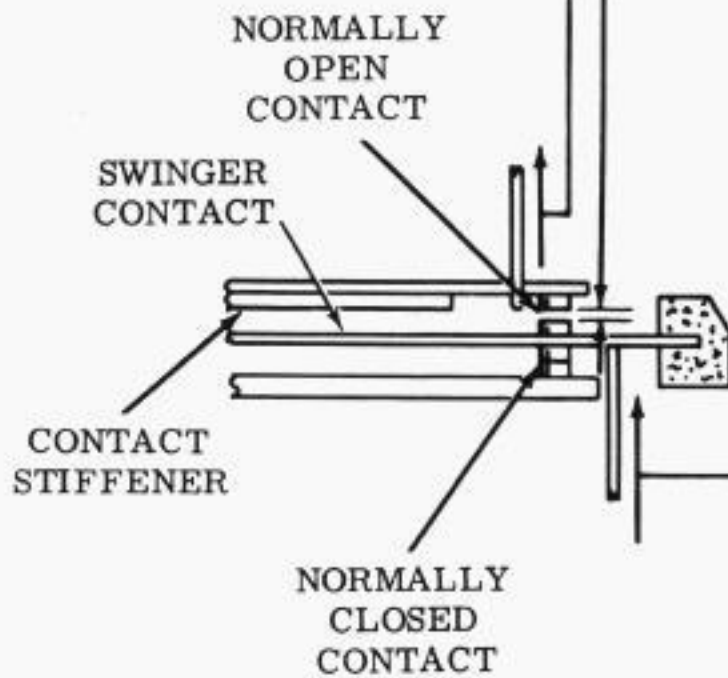

(Front View)

NORMALLY CLOSED CONTACTS

Requirement  
 It should require  
 Min 4 oz --- Max 5 oz  
 to open the normally closed contact.

To Adjust  
 Bend the swinger contact to meet requirement.

2.47 Auxiliary Contacts (continued)

Secondary Adjustments

Note 1: The secondary adjustments should be made with the auxiliary contact assembly installed in the reader unit.

CONTACT ASSEMBLY POSITION — PRELIMINARY

(1) Requirement

With clutch disengaged and latched, clearance between the insulator on the contact swinger and the bail

Min 0.040 inch --- Max 0.050 inch

To Adjust

Position the contact bracket with its mounting screws loosened. Tighten screws.

Note 2: To insure signal stability, contact alignment is obtained in the factory sub-assembly stage under closely controlled conditions and normally the contact assembly screws should not be disturbed. For optimum performance, if the contact points become worn it is recommended that the complete "contact assembly with bracket" be replaced.

Note 3: For final adjustment, see CONTACT SWINGER — OPERATING BAIL CLEARANCE

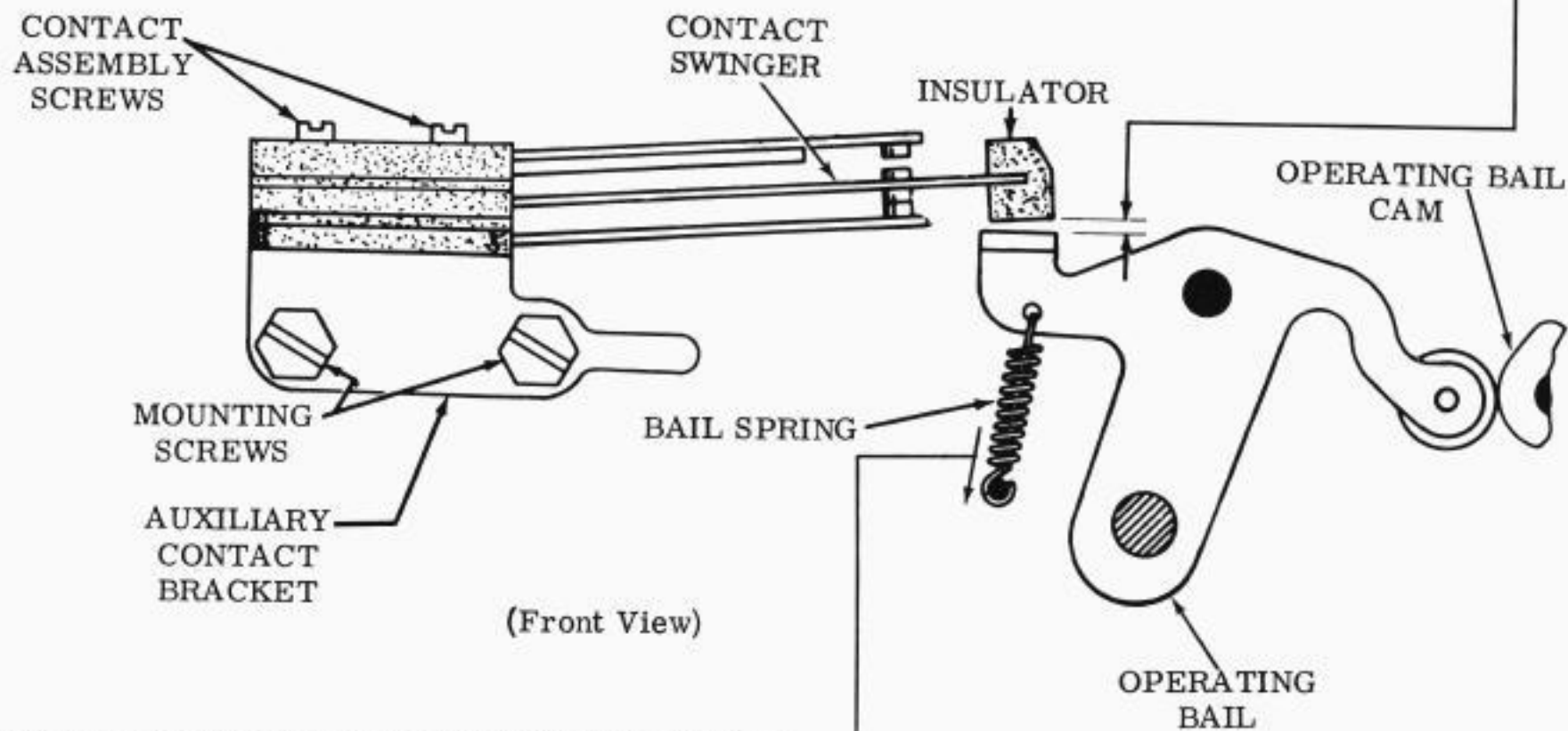

AUXILIARY CONTACT OPERATING BAIL SPRING

Requirement

Clutch disengaged and unit inverted, it should require

Min 5 oz --- Max 7 oz  
to pull spring to installed length.

Note: Replace contact box assembly and check its associated adjustments.



## 2.48 Auxiliary Contacts (continued)

## Final Adjustments (Strobing)

CONTACT SWINGER — OPERATING BAIL CLEARANCE

Note: When strobing the auxiliary contacts, use a DXD scale (when available) whose unit code corresponds to that of the unit being checked. (See CONTACT OPERATING REQUIREMENTS TABLE.) The signal generator of the reader should be synchronized with the DXD so that the end of the stop pulse image is in line with the end of the stop pulse on the DXD scale when transmission is continuous. Normal signal line current of 60 ma + 10 percent or 20 ma + 10 percent should be used to strobe the contacts. Current applied to these contacts is dc.

## Requirement

The contacts should open and close within the range specified on the CONTACT OPERATING REQUIREMENTS TABLE.

## To Adjust

Refine CONTACT ASSEMBLY POSITION — PRELIMINARY as follows:

Loosen the contact assembly bracket mounting screws and position the contact assembly to meet requirements. Tighten screws.

CONTACT OPERATING REQUIREMENTS TABLE

LEVELS	UNIT CODE	START OF PULSE			END OF PULSE		
		SCALE SEGMENT	SCALE DIVISIONS	TOLERANCE DIVISIONS	SCALE SEGMENT	SCALE DIVISIONS	TOLERANCE DIVISIONS
8	11.00	PULSE 2	60	+25	PULSE 7	30	+25

## 2.49 Timing Contact Mechanism (continued)

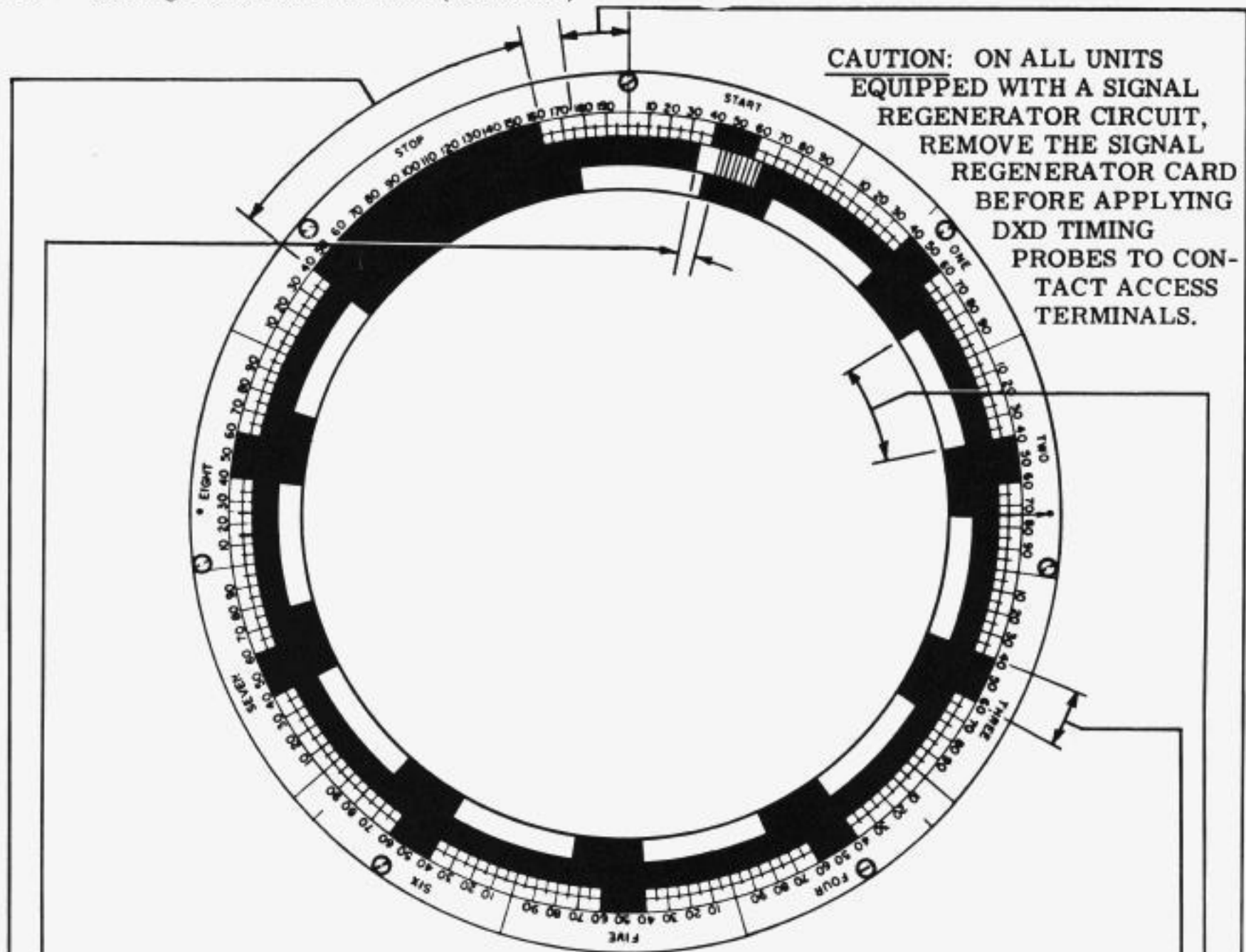
TIMING CONTACT REQUIREMENT

- (1) Zero the test set as previously described (2.39).
- (2) The light image of the timing contacts should meet the following requirements for speeds up to and including 100 wpm.
  - (a) Open for a minimum of 20 divisions between the 25 division and 75 division points of each 100 division pulse.
    - Open for a minimum of 120 divisions between the 25 division and 175 division points of the stop pulse.
  - (b) The close to open transitions should be in multiples of 100 divisions  $\pm 5$  divisions from the close to open transition of the start pulse.
  - (c) There should be no contact break between the 0 division point and the close to open transition point and no contact break between the 75 division point and 100 division point of each pulse. There should be no contact break between 175 division point and the 200 division point of the stop pulse.

2.50 Timing Contact Mechanism (continued)

TIMING CONTACT REQUIREMENT (continued)

- (d) Check and refine, if necessary, TIMING CONTACT BRACKET — PRELIMINARY adjustment.
- (e) The timing contacts should be open in the rest position of the reader unit.

To Adjust

Loosen the two timing contact bracket mounting screws until they are friction tight. Position the timing contact assembly by means of the screwdriver lug on the bracket, visible through a hole in the rear plate, so that the requirements are met. Tighten the screws and recheck the image on the DXD stroboscope.