

HIGH SPEED TAPE PUNCH UNIT (DRPE TYPE)

LUBRICATION

CONTENTS	PAGE
1. GENERAL	1
2. BASIC UNIT	2
Antireverse pawl and pulley	6
Escapement pawls, ratchet, and grease retainer	3
Idler lever and gear	4
Links and reed tips	2
Pressure roller	3
Tape feed motor	5
Tape guide shaft	3
Tape guide spring and spur gear	4
Tape puller motor	5
Tape sensing lever	6
3. VARIABLE FEATURES	7
Backup mechanism	8
Detent lever assembly	12
Drive shaft assembly	14
Escapement assembly (forward feed wheel)	14
Intermediate shaft assembly	9
Reverse feed wheel assembly	13
Switch lever assembly	9
Tape guide assembly	13
Trip magnet assembly	15
Photoelectric reader (verifier)	8
Universal punch block	7

1. GENERAL

1.01 This section provides lubrication information for the high speed tape punch (DRPE type). It is reissued to add and revise lubrication information according to the latest engineering changes. These include new 2400 word per minute models and variable features such as a backup mechanism, photoelectric reader (verifier), and universal punch block. Because this is a general revision, marginal arrows which indicate change have been omitted.

1.02 The high speed tape punch should be lubricated as directed in this section. The figures indicate points to be lubricated and the

kind and quantity of lubricant to be used. Lubricate the unit just prior to placing it in service. After a few weeks of service, relubricate to make certain that all points receive lubrication. Thereafter, the lubrication interval is:

<u>Operating Speed</u> (Words per Minute)	<u>Lubrication</u> <u>Interval</u>
100	2000 hr or 6 mo*
500	400 hr or 3 mo*
1000	200 hr or 2 mo*
1500	150 hr or 1-1/2 mo*
2000	75 hr or 1 mo*
2400	40 hr or 1 mo*

* Whichever occurs first.

1.03 Use KS7470 oil and Mobil #2 grease when lubricating this unit. See section 570-005-800TC for complete list of tools.

Note: TP143484 is a 1 lb can of Mobil #2 grease. TP145867 is the same grease in a 4 oz tube.

1.04 Saturate all spring wicks and felt oilers; lubricate friction surfaces of all moving parts. Avoid overlubrication. Prevent lubricant from getting between electrical contacts or between stepper magnet coils and armature.

1.05 The photographs indicate paragraph numbers that refer to specific line drawings of mechanisms and where these mechanisms are located on the equipment. Mechanisms in line drawings are shown upright unless otherwise specified.

1.06 The illustration symbols indicate the following lubrication directions:

- O1 - Apply one drop of oil.
- O2 - Apply two drops of oil, etc.
- SAT - Saturate with oil (felt oilers, washers, and wicks).
- FILL - Fill with oil (oil holes and oil cups).
- G - Apply 1/64-inch film of grease unless directed otherwise.

1.07 After each lubrication interval, wipe off excess lubricant from upper tape guide-plate and punch pins.

2. BASIC UNIT

2.01 Front of Unit

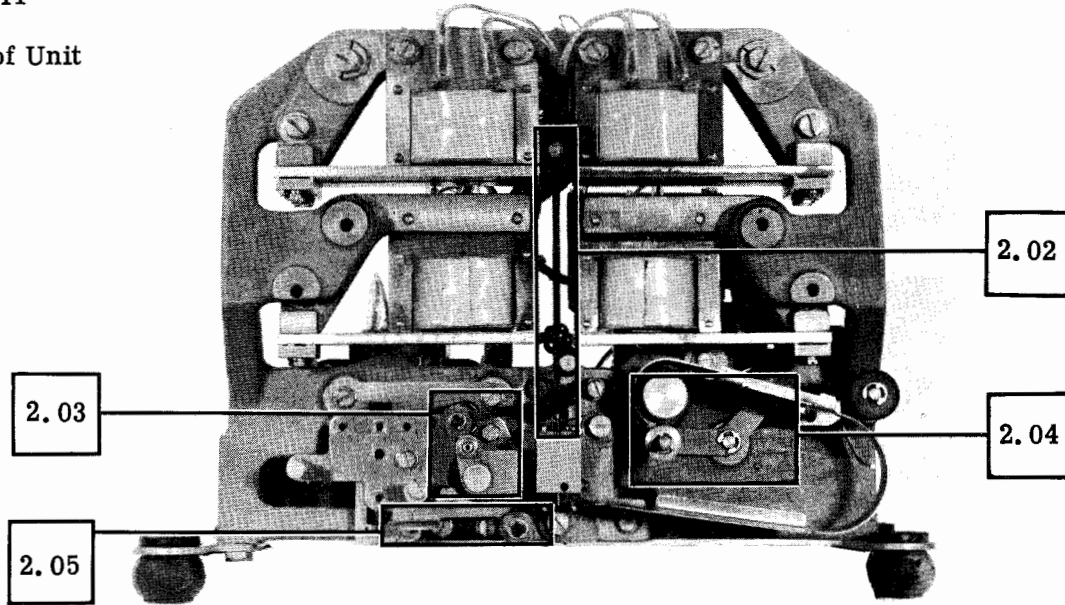

2.02 Links and Reed Tips

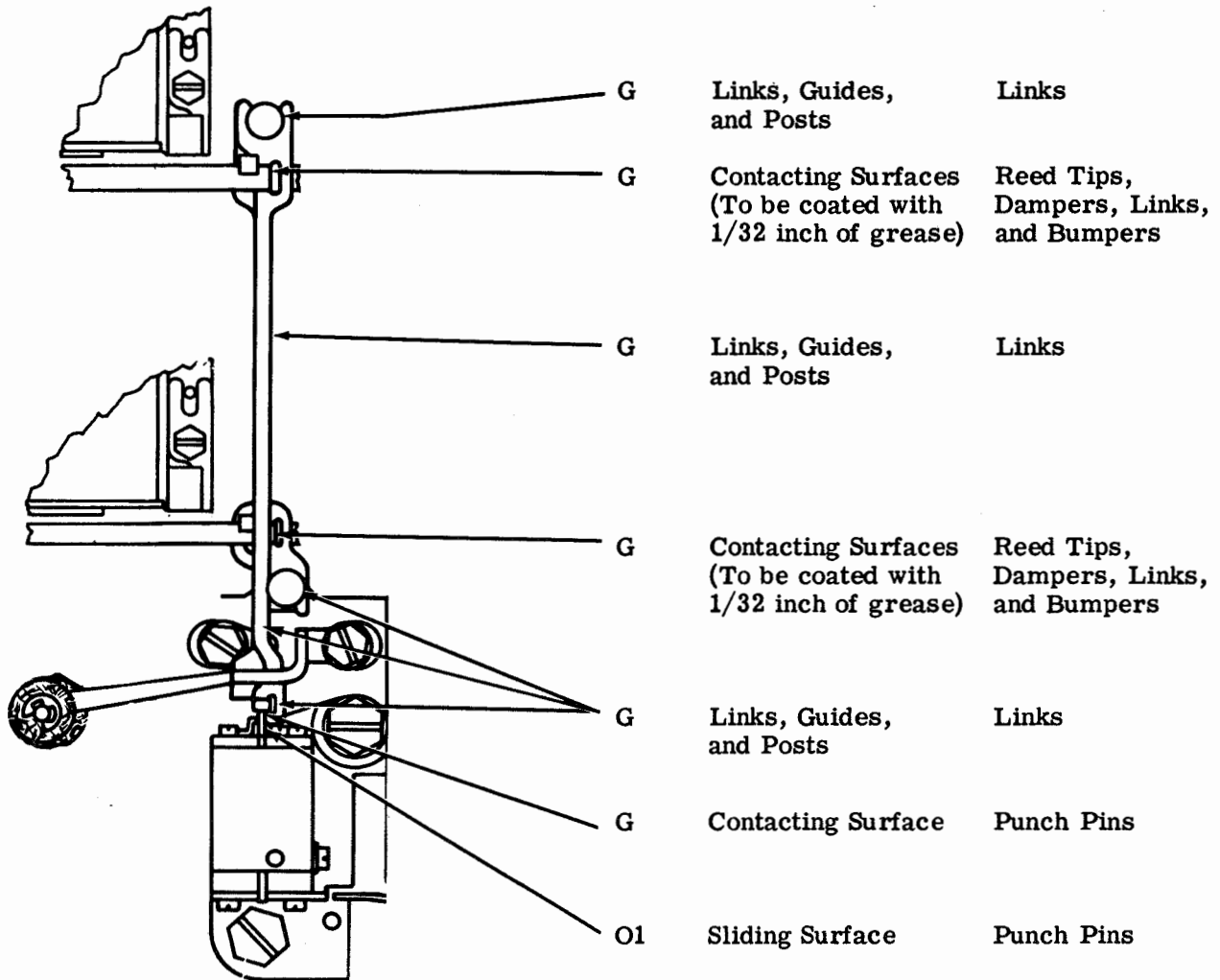

2.03 Escapement Pawls, Ratchet, and Grease Retainer

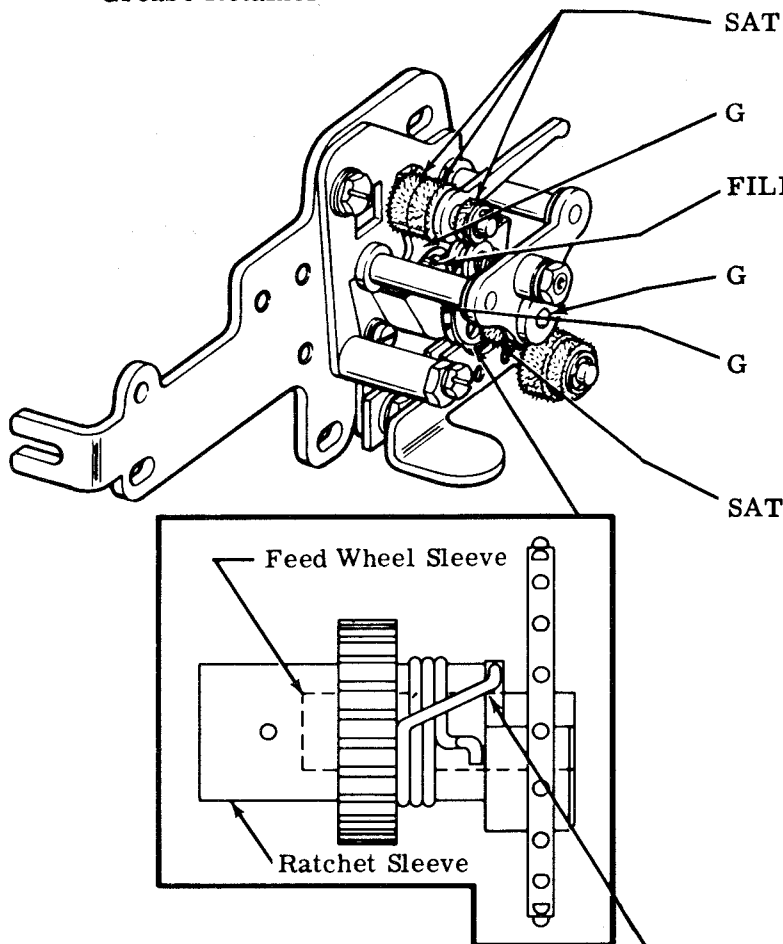

- SAT Felt Washers Escapement Pawl Shaft
- G Contact Surfaces Escapement Pawl
- FILL Fill Grease Retainer if Present Escapement Ratchet
- G Shaft Hole - See Note Feed Wheel Shaft
- G Spring Coils, Feed Wheel Shaft Surface Feed Wheel Shaft and Yield Spring
- SAT Felt Washer (Late Design) Feed Wheel Shaft

Note: If there is a hole through feed wheel shaft, apply lubricant to hole until it flows through to hole on ratchet. If there is no hole, disassemble feed and ratchet wheel assemblies as outlined in disassembly section. After re-assembly, block feed wheel center hole and two cross holes in ratchet sleeve. Apply lubricant against end of ratchet sleeve until it flows from hole in ratchet sleeve.

2.04 Pressure Roller

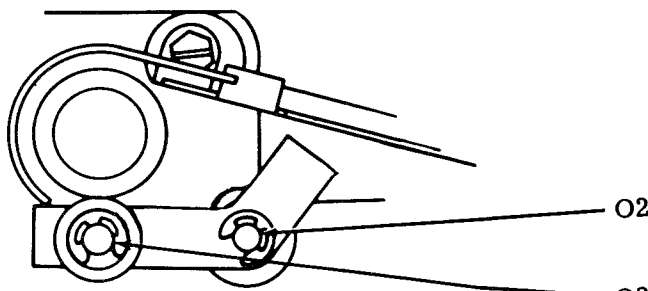

- G Contact Surface Feed Wheel Spoke and Ratchet
- O2 Each Pivot Bearing Pressure Roller Bail
- O2 Oilite Bearing (Each End) Pressure Roller

2.05 Tape Guide Shaft

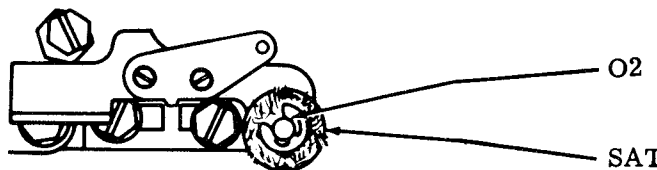

- O2 Rear of Bearing Tape Guide Shaft
- SAT Felt Washer Bearing

SECTION 592-803-701

2.06 Bottom of Unit

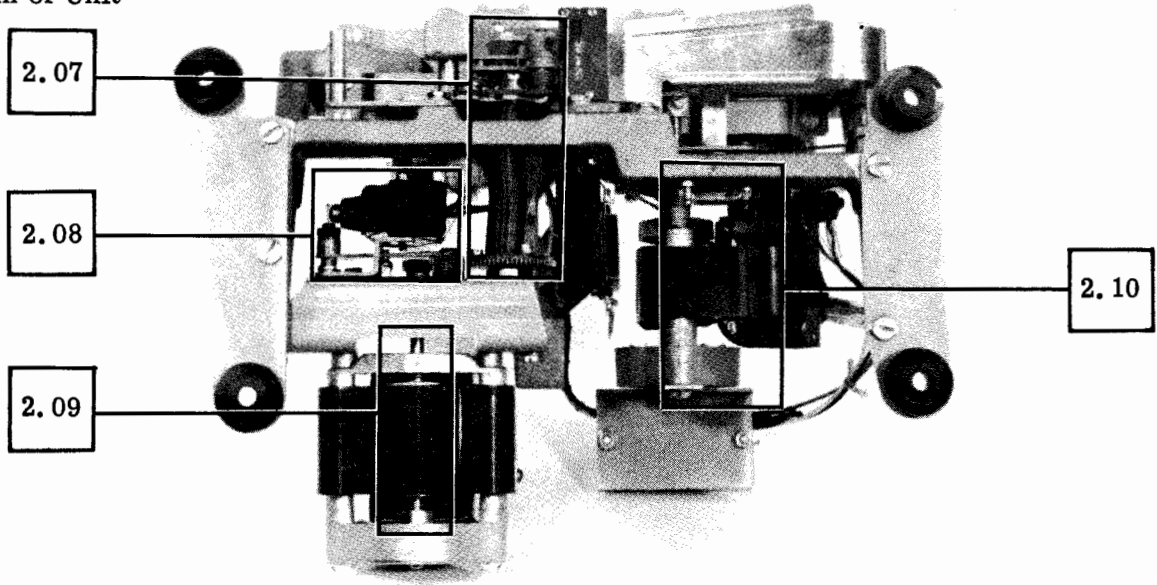

2.07 Tape Guide Spring and Spur Gear

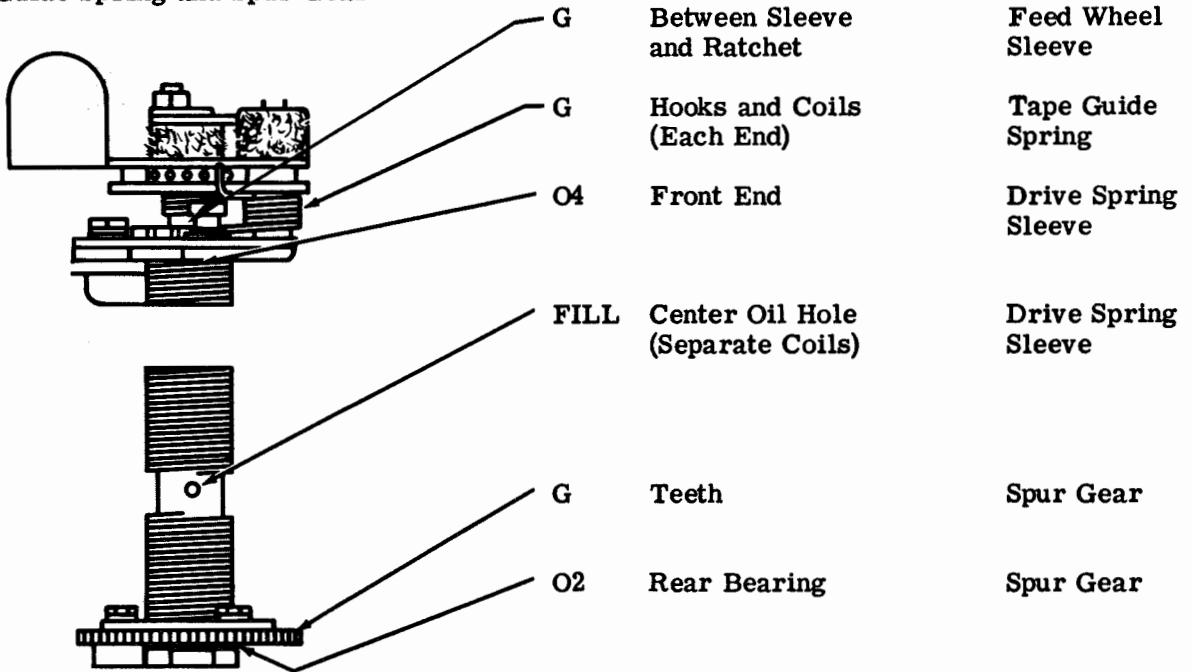

2.08 Idler Lever and Gear

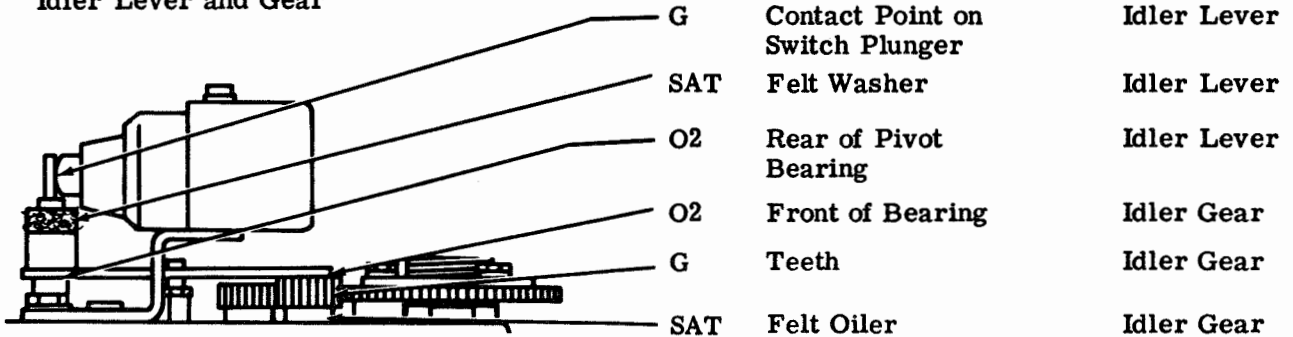

2.09 Tape Feed Motor

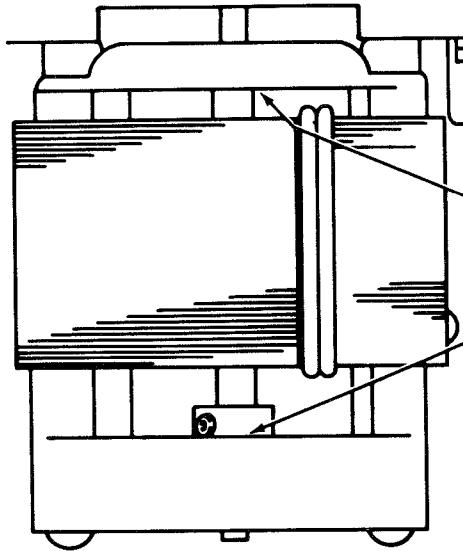
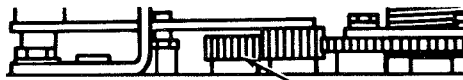

G Teeth Feed Motor Pinion

SAT Felt Washers (2) (Inside Castings) Tape Feed Motor

2.10 Tape Puller Motor

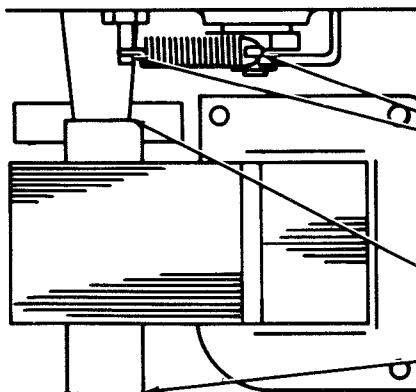

O1 Hooks (Each End) Pressure Roller Spring

SAT Felt Washers (2) (Inside Castings) Tape Puller Motor

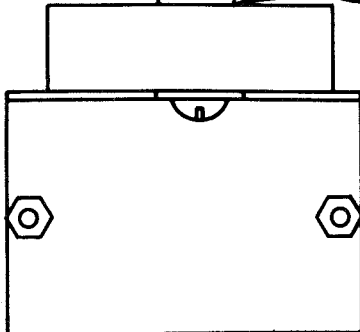

2.11 Top of Unit

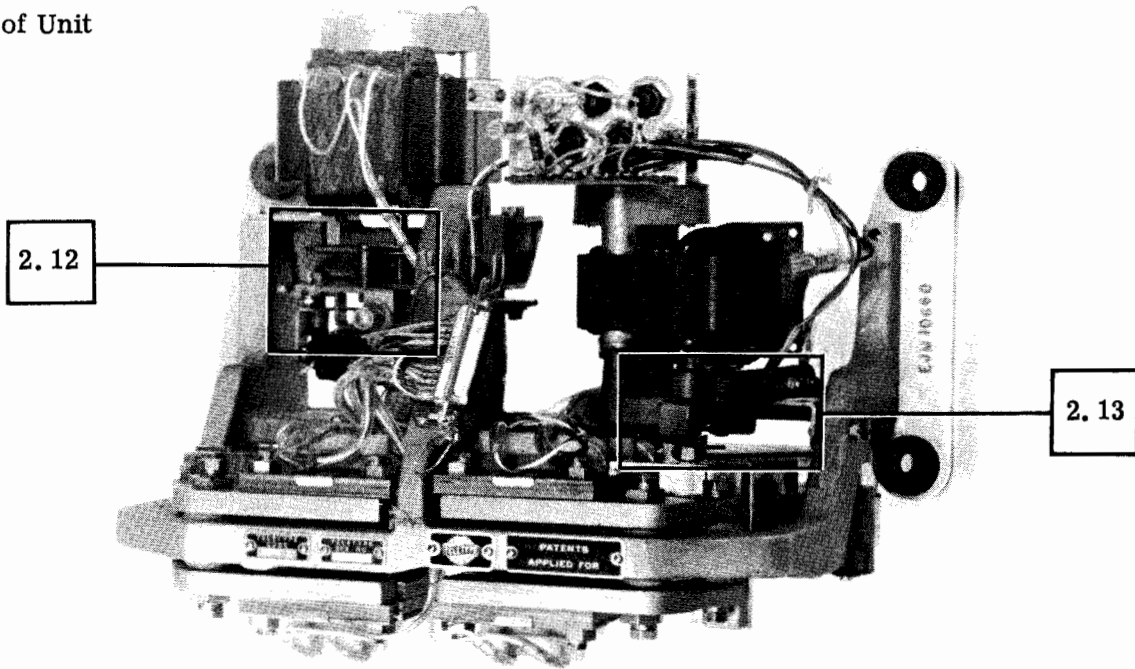

2.12 Antireverse Pawl and Pulley

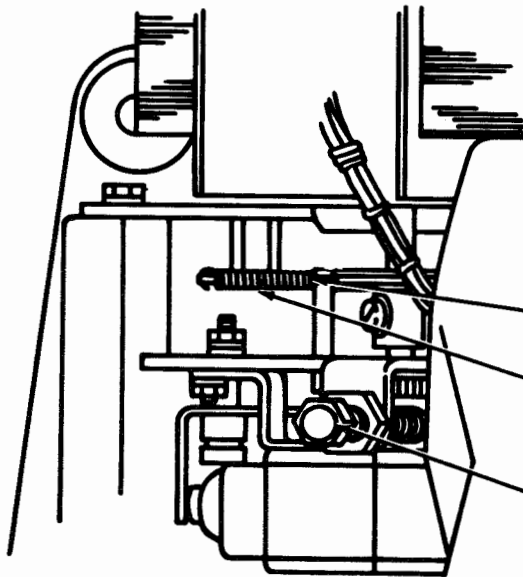

Note: The antireversal pawl is intended to operate without lubrication. Clean pawl and V-groove pulley with suitable solvent at lubricating intervals.

- | | | |
|----|-------------------------|-----------------------------|
| O1 | Spring Hooks (Each End) | Antireverse Pawl Spring |
| O2 | Lever Pivot | Antireverse Pawl and Pulley |
| O2 | Spring Hooks (Each End) | Idler Lever Spring |

2.13 Tape Sensing Lever

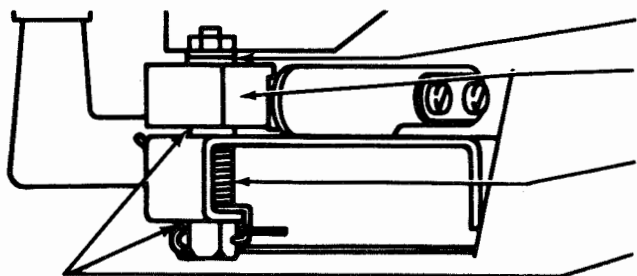

- | | | |
|----|------------------------|---------------------------|
| O1 | Cam Shaft | Contact Arm |
| G | Switch Cam | Tape Sensing Lever Switch |
| G | Spring Hooks and Coils | Tape Sensing Lever Spring |
| O1 | Lever Bearings | Sensing Lever |

3. VARIABLE FEATURES

3.01 High Speed Tape Punch

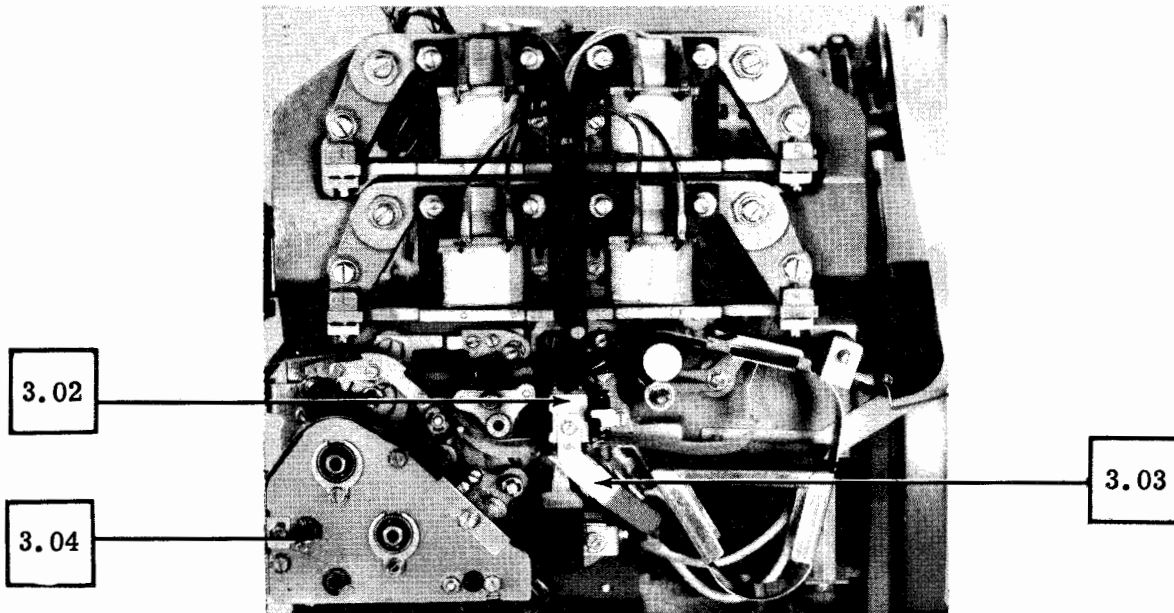

3.02 Universal Punch Block

Note: The universal punch block lubrication procedures are the same as the standard punch mechanism. See 2.02 and 2.03.

CAUTION 1: EXCESS OIL ON PAPER TAPE MAY PREVENT DATA FROM BEING SENSED CORRECTLY.

CAUTION 2: WHEN LUBRICATING UNIVERSAL PUNCH BLOCK, DO NOT SPRAY LUBRICANT ON COVER OF LIGHT SOURCE.

SECTION 592-803-701

3.03 Photoelectric Reader (Verifier)

Note: The photoelectric reader (verifier) does not require lubrication.

3.04 Backup Mechanism

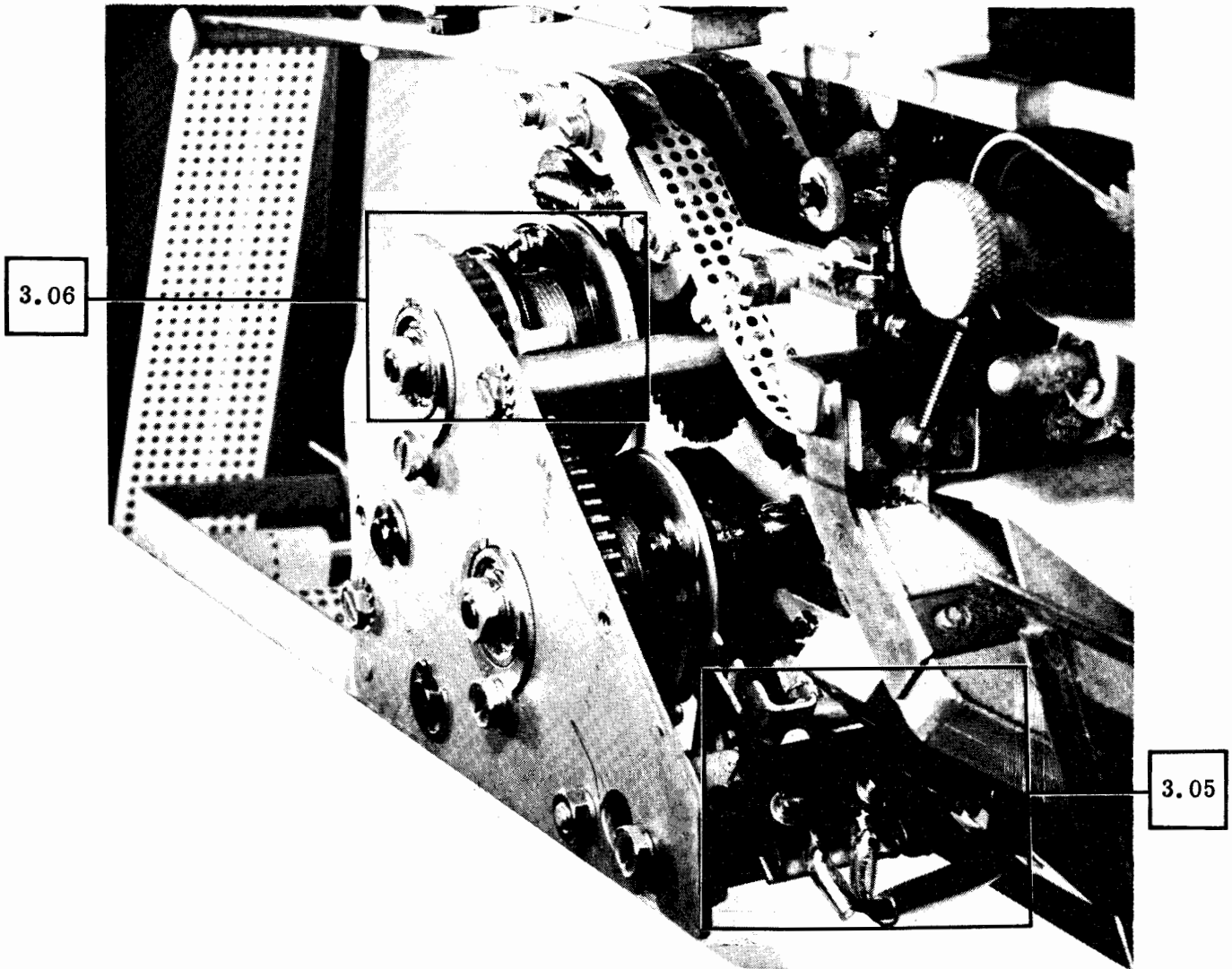

3.05 Switch Lever Assembly

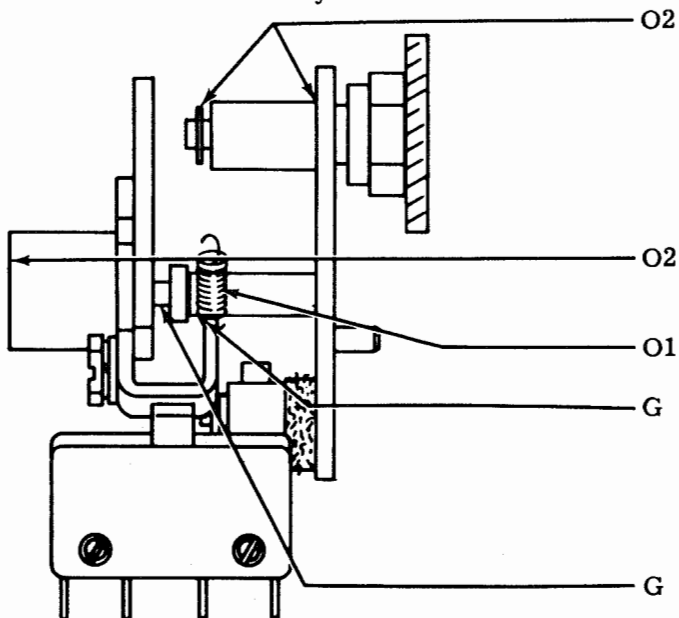

- O2 Bearing Surfaces Switch Lever Operating Post
- O2 Contact Surfaces Switch Lever Hub
- O1 Coils Tape Lid Spring
- G Hooks (Each End) Tape Lid Spring
- G Mating Surfaces Switch Lever Eccentric Post

3.06 Intermediate Shaft Assembly

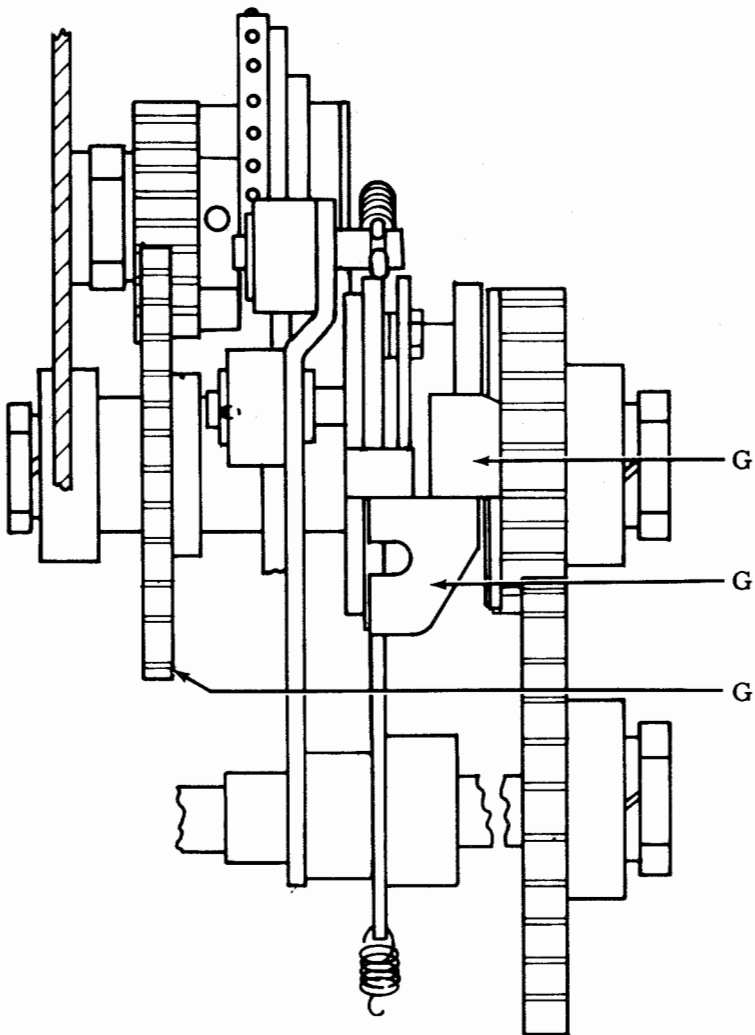

- G Mating Surface Clutch Latch-lever Release
- G Mating Surface Clutch Disc Lug
- G Gear Teeth Intermediate Shaft Gear

3.07 Detent Lever and Reverse Feed Wheel

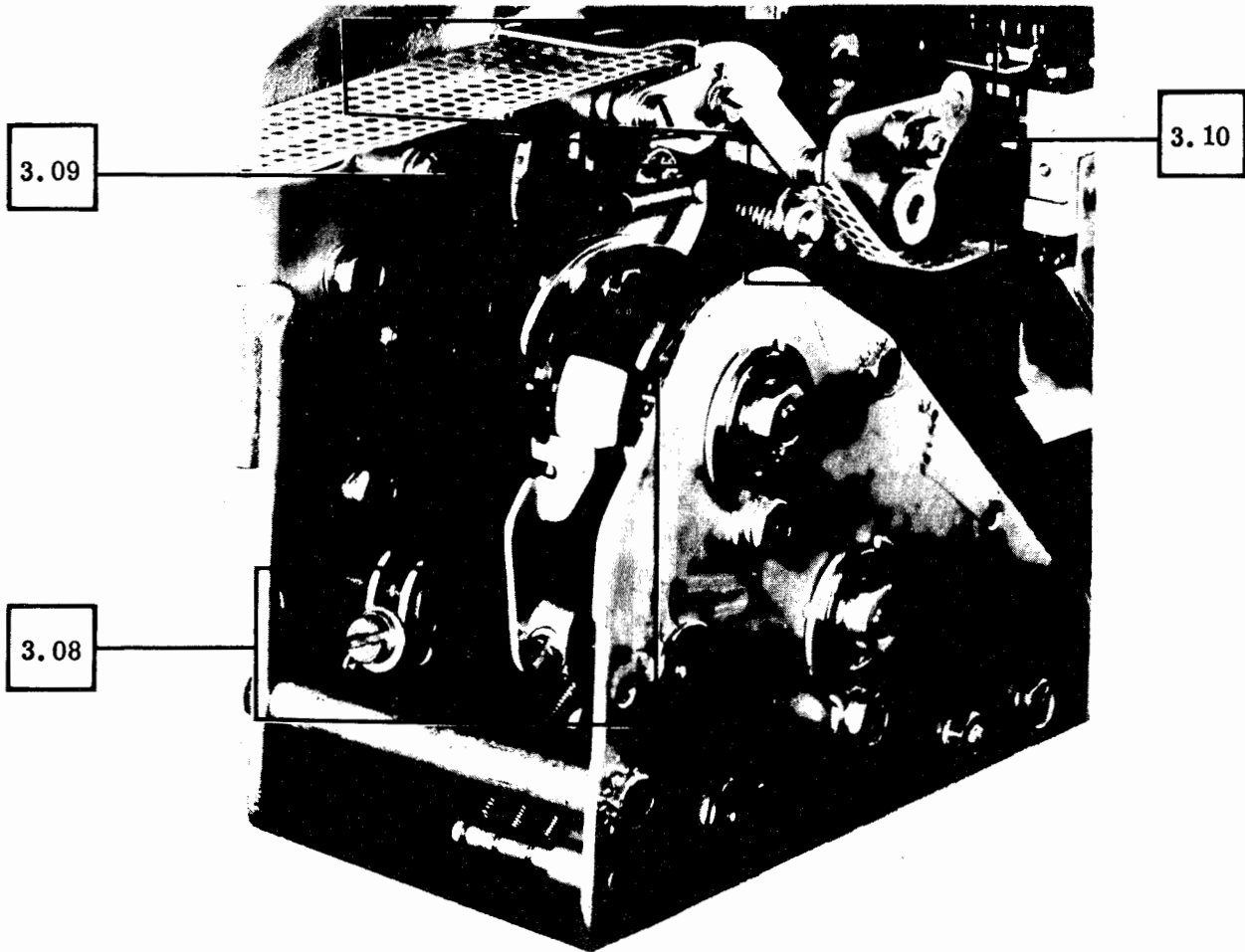

3.08 Detent Lever Assembly

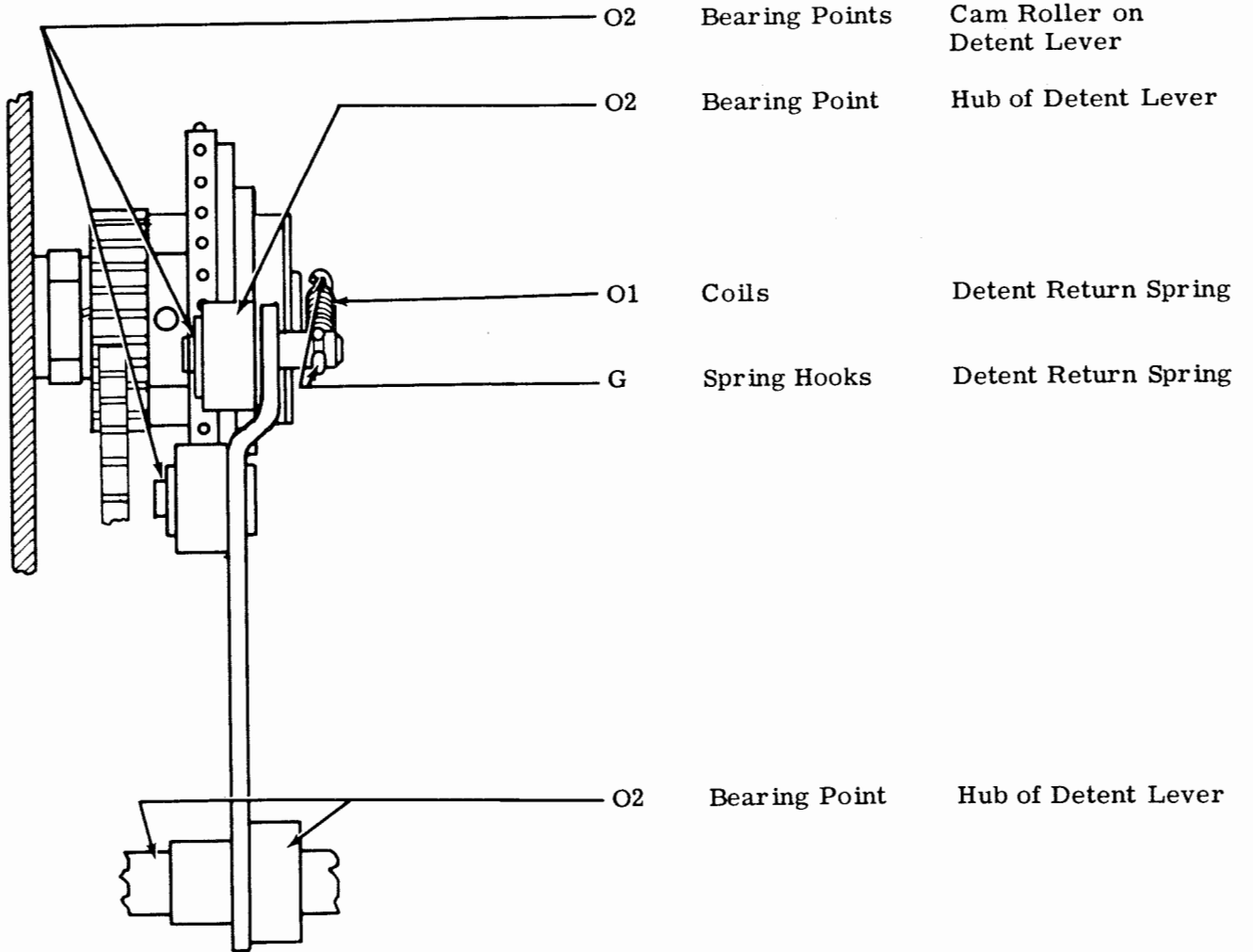

3.09 Reverse Feed Wheel Assembly

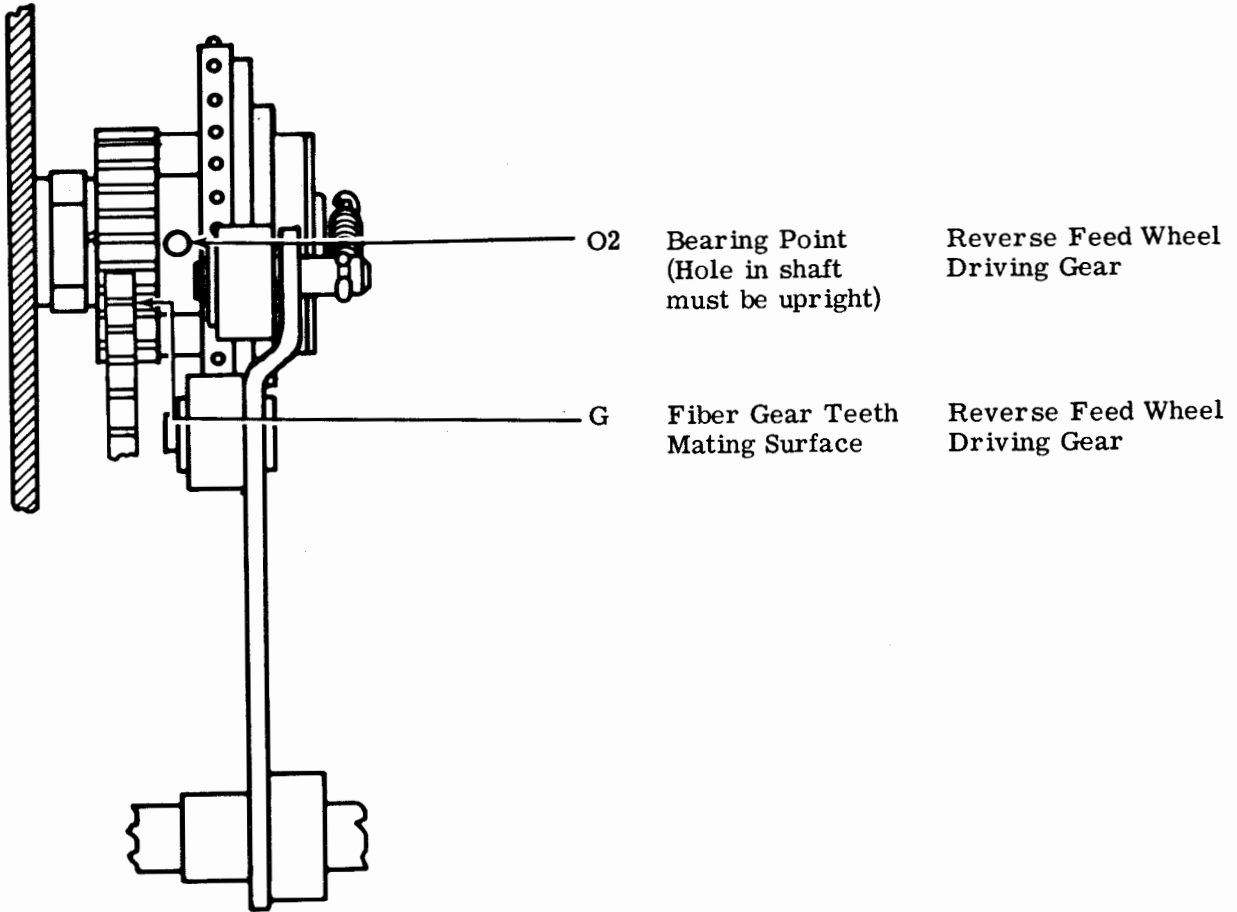

3.10 Tape Guide Assembly

See 2.05 through 2.07

3.11 Escapement, Drive Shaft, and Trip Magnet Assemblies

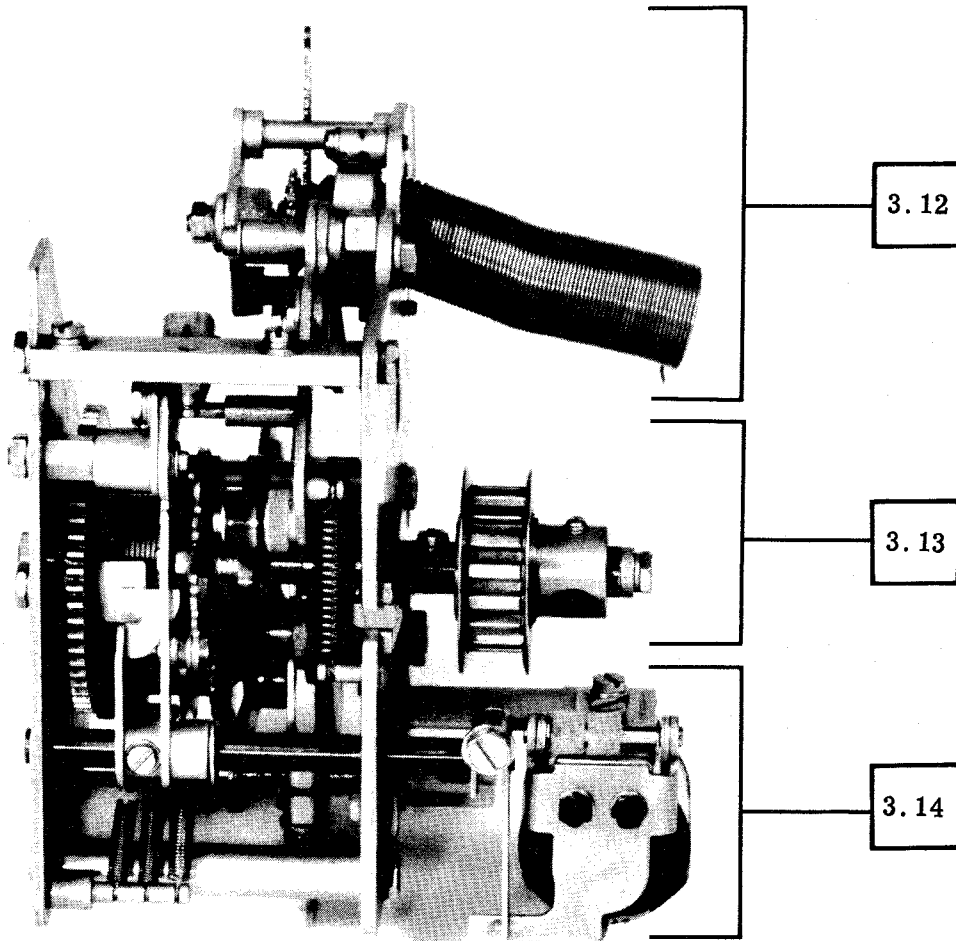

(Bottom View)

SECTION 592-803-701

3.12 Escapement Assembly (Forward Feed Wheel)
See 2.03 through 2.13

3.13 Drive Shaft Assembly

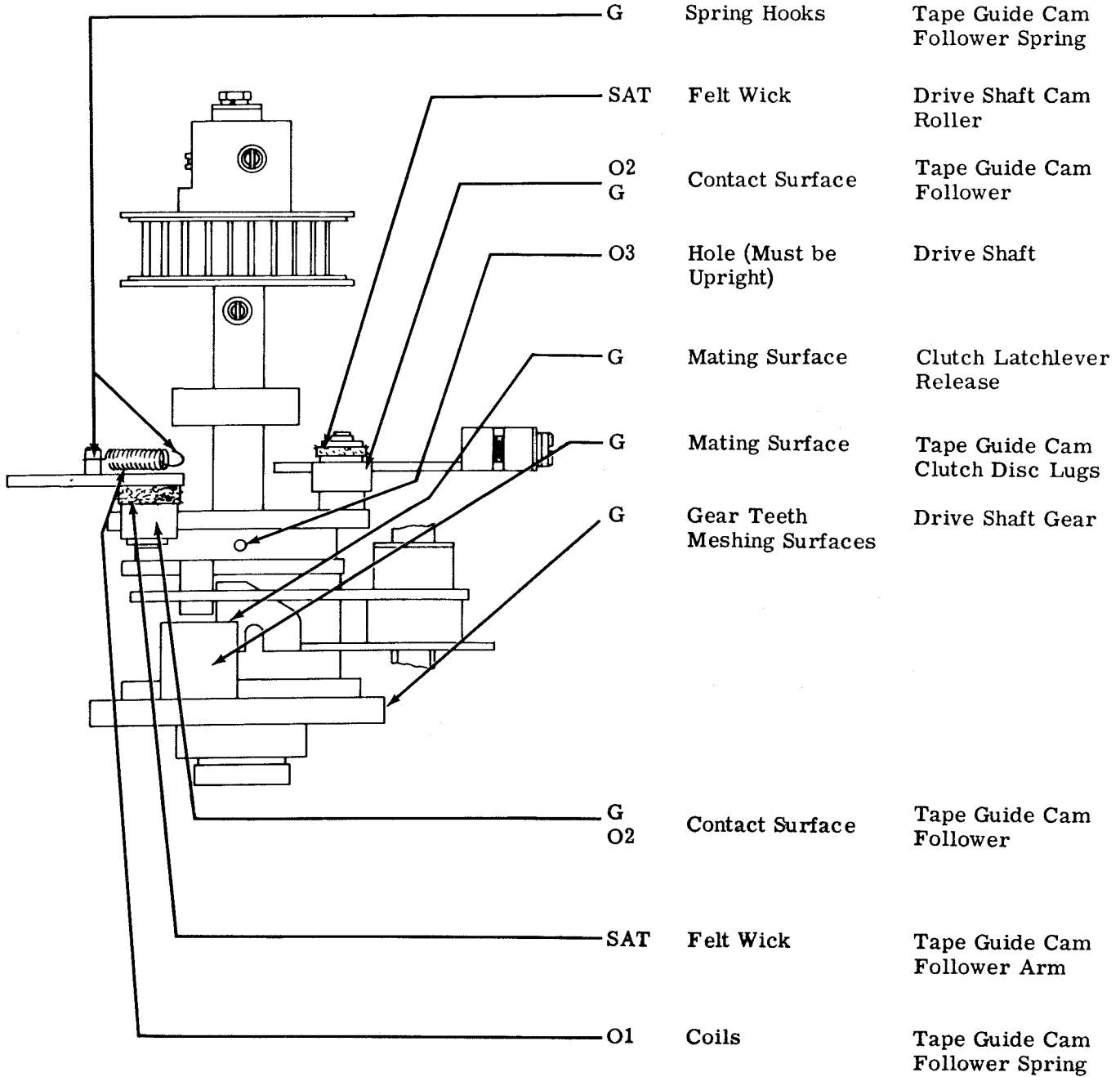

3.14 Trip Magnet Assembly

