

DEPARTMENT OF THE ARMY TECHNICAL MANUAL

TM 11-2277

DEPARTMENT OF THE AIR FORCE TECHNICAL ORDER

TO31W4-2FG-1141

TELETYPEWRITER
DISTRIBUTOR - TRANSMITTERS
TT-122A/FG AND TT-123/FG



DEPARTMENTS OF THE ARMY AND THE AIR FORCE

JANUARY 1958

WARNING

DANGEROUS VOLTAGES EXIST IN THIS EQUIPMENT

Be careful when working on the 115-volt motor circuits. Serious injury or death may result from contact with these circuits. Turn off the power before making any connections or replacing any parts inside the equipment.

DON'T TAKE CHANCES!

T
M
T
B

TA

TECHNICAL MANUAL
No. 11-2277
TECHNICAL ORDER
No. 31W4-2FG-1141

DEPARTMENTS OF THE ARMY
AND THE AIR FORCE

WASHINGTON 25, D. C., 13 January 1958

TELETYPEWRITER DISTRIBUTOR-TRANSMITTERS TT-122A/FG AND TT-123A/FG

	Paragraphs	Page
CHAPTER 1. INTRODUCTION		
Section I. General	1, 2	3
II. Description and data	3-8	3
 CHAPTER 2. INSTALLATION AND OPERATING INSTRUCTIONS		
Section I. Service upon receipt of equipment	9, 10	6
II. Installation	11-17	8
III. Operating procedures	18-20	10
 CHAPTER 3. ORGANIZATIONAL MAINTENANCE		
Section I. First echelon maintenance	21-24	13
II. Second echelon maintenance	25-28	16
III. Lubrication	29-34	19
IV. Troubleshooting at organizational maintenance level	35-38	25
V. Distributor-transmitter adjustment procedures	39-57	26
 CHAPTER 4. THEORY		
Section I. Introduction	58-60	34
II. Detailed mechanical theory	61-73	36
III. Circuit descriptions	74-77	44
 CHAPTER 5. FIELD MAINTENANCE		
Section I. Prerepair procedures	78, 79	50
II. Inspecting, cleaning, and lubricating	80-83	50
III. Troubleshooting at field maintenance level	84-87	52
IV. Removal and replacement	88-105	54
V. Spring data	106-110	78
VI. Final testing	111-114	80
 CHAPTER 6. SHIPMENT AND LIMITED STORAGE AND DEMOLITION TO PREVENT ENEMY USE		
Section I. Shipment and limited storage	115, 116	82
II. Demolition to prevent enemy use	117, 118	82
 INDEX		 83

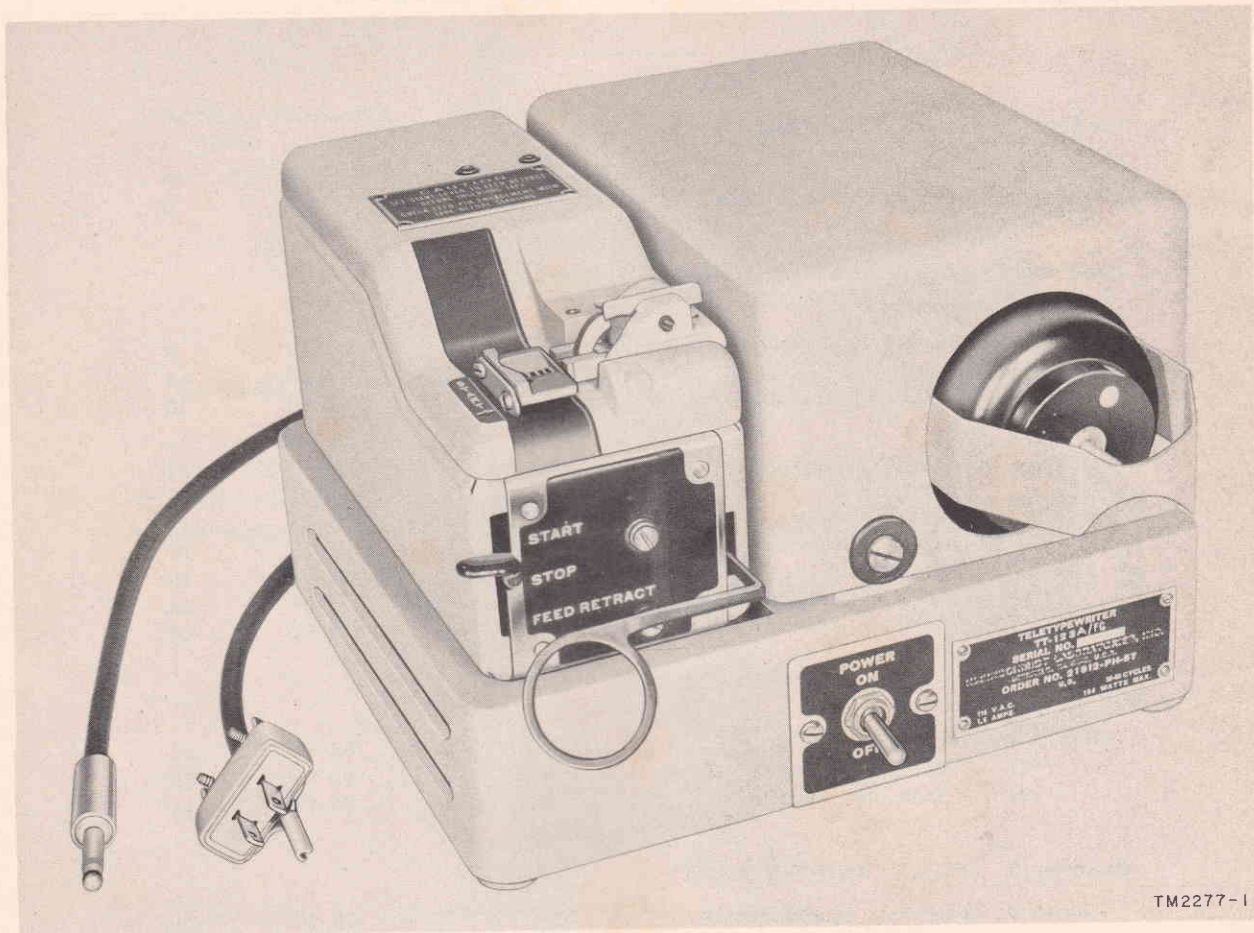

Figure 1. Teletypewriter Distributor-Transmitter TT-123A/FG.

CHAPTER 1

INTRODUCTION

Section I. GENERAL

1. Scope

a. This manual contains information on the installation, operation, theory, maintenance, and repair of Teletypewriter Distributor-Transmitters TT-122A/FG and TT-123A/FG. The information in this manual is applicable to both equipments unless specific reference is made to a given equipment.

b. Forward all comments on this publication directly to—Commanding Officer, U. S. Army Signal Publications Agency, Fort Monmouth, New Jersey.

2. Forms and Records

a. *Unsatisfactory Equipment Report.* Fill out and forward DA Form 468 (Unsatisfactory Equipment Report) to Commanding Officer, U. S. Army Signal Equipment Support Agency, Fort Monmouth, N. J., as prescribed in AR 700-38.

b. *Report of Damaged or Improper Shipment.* Fill out and forward DD Form 6 (Report of Damaged or Improper Shipment) as prescribed in AR 700-58 (Army).

c. *Preventive Maintenance Forms.* Prepare DA Form 11-252 (Maintenance Check List for Signal Equipment, Teletypewriter) figs. 7 and 8), in accordance with instructions on the form.

Section II. DESCRIPTION AND DATA

3. Purpose and Use

a. Teletypewriter Distributor-Transmitters TT-122A/FG and TT-123A/FG (fig. 1) are lightweight, motor-driven tape transmitters that translate code perforations in $\frac{7}{8}$ -inch or $1\frac{1}{16}$ -inch paper tape into electrical impulses.

b. The TT-122A/FG and TT-123A/FG are used in fixed station and mobile communication centers to transmit start-stop, five-unit code impulses to—

- (1) Teletypewriter receiving units over direct-current (dc) wire lines (A, fig. 2).
- (2) Carrier or radio telegraph equipment with or without Telegraph Terminal TH-5/TG or other converter equipment (B, fig. 2).

4. Technical Characteristics

The technical characteristics of the TT-122A/FG and TT-123A/FG are identical, except for the type of motor and the power requirements.

Type of installation.....Mobile or fixed station.
Signaling code7.42 start-stop five-unit.
Type of signalsNeutral (20 or 60 ma).
Operating speed:
Operations-per-minute.....368.1 and 600 opm.
Words-per-minute60 and 100 wpm.
Motor:
Power requirements:
TT-122A/FG115-w, 115-volt, 60-cps,
single-phase ac.
TT-123A/FG184-w, 105- to 125-volt,
50-60-cps, single-phase ac.
Speed (both models).....3,600 rpm (± 5 percent).
Type:
TT-122A/FGSynchronous.
TT-123A/FGSeries-governed.

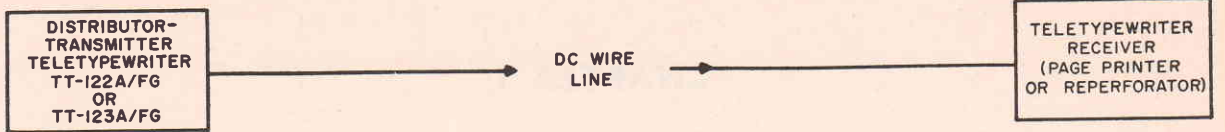

A. DIRECT WIRE LINE

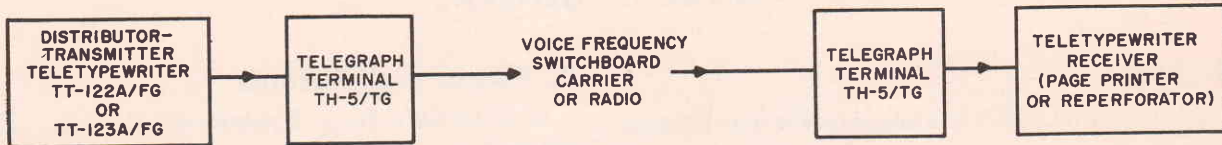

B. VF CARRIER OR RADIO EQUIPMENT

TM2277-2

Figure 2. Typical application, block diagram.

- Suppression of interference with radio reception..... Does not interfere with radio reception at frequencies between .35 and 150 mc when located 1 ft or more from the radio antenna.
- Safety shielding Points at which potentials of 30 volts or more exist are shielded against accidental contact by personnel.
- Surrounding temperature limits:
 Equipment in use..... 32° F. (0° C., to 132° F. (55.6° C.).
 Equipment in storage.. —80° F. (—62.2° C.) to 160° F. (71.1° C.).
- Minimum barometric pressure:
 Operating 16.88 in. mercury (equivalent to 15,000-ft altitude).
 In transportation 5.5 in. mercury (equivalent to 40,000-ft altitude).
- Other climatic conditions... Withstands high humidity and moisture encountered in the tropics; is fungi-proofed and corrosion-resistant.
- Distortion tolerance in transmitted signals ±5 percent max at 368.1 opm on dc line.
- Total weight 17 lb, 3 oz.

5. Components of Teletypewriter Distributor - Transmitters TT-122A/FG and TT-123A/FG

Quantity	Item	Height (in.)	Depth (in.)	Width (in.)
1	Distributor-transmitter	6 ⁹ / ₁₆	10 ¹ / ₂	9 ⁵ / ₈
1	Worm gear (600 opm)	3/4	1 ¹ / ₄	
1	Motor-driven gear (600 opm)	1 ³ / ₁₆	2 ¹ / ₂	
2	TM 11-2277			
5	Fuse (1.6 amp, TT-123A/FG) (1 amp, TT-122A/FG)			

6. Nomenclature and Common Names

The term *distributor-transmitter* is the common name used in this manual for Teletypewriter Distributor-Transmitter TT-122A/FG and Teletypewriter Distributor-Transmitter TT-123A/FG.

7. Description of Teletypewriter Distributor - Transmitters TT-122A/FG and TT-123A/FG

Each distributor-transmitter consists of a tape transmitter, a motor, and a rectangular base (fig. 6). A dust cover, secured to the base frame by three shoulder screws, covers the motor and driving gears of the unit. A

POWER switch is mounted on the front of the base. A power cord, signal cord, and two fuse holders extend from the rear of the base.

8. Difference in Models

Item	Distributor- Transmitter, Teletypewriter TT-122A/FG	Distributor- Transmitter, Teletypewriter TT-123A/FG
Motor type. Guard on dust cover.	Synchronous. Not included.	Series-governed. Includes guard to protect target wheel and gov- ernor adjusting worm shaft.
Fuses.	Uses two 1-amp fuses.	Uses two 1.6-amp fuses.
Motor circuit components.	See figure 45.	See figure 46.

CHAPTER 2

INSTALLATION AND OPERATING INSTRUCTIONS

Note. The procedures described in sections I and II should be performed by organizational maintenance personnel.

Section I. SERVICE UPON RECEIPT OF EQUIPMENT

9. Unpacking

a. Packaging Data (fig. 3). When packed for shipment, each distributor-transmitter is fastened to a wooden shipping base with four machine screws and flat washers. The distributor-transmitter and wooden shipping base are then placed on a 5/16-inch fiberboard cushion in a fiberboard carton, 13 inches deep by 11 $\frac{7}{8}$ inches wide by 8 inches high. Folded corrugated liners are inserted at both sides of the distributor-transmitter and a corrugated top liner is placed on top. The fiberboard carton is then closed and sealed with tape. Two technical manuals, sealed in a vaporproof bag, are taped to the top of the carton. Four fiberboard cartons are then placed in a single wooden shipping container 26 $\frac{3}{4}$ inches long by 24 $\frac{1}{2}$ inches deep by 9 inches high. The wooden box cover is nailed securely to the box. The shipping container occupies 4.3 cubic feet and weighs approximately 100 pounds.

b. Removing Contents. Unpack each wooden box by following the procedures outlined in (1) through (6) below.

Caution: Be careful when unpacking the equipment. Do not thrust tools into the interior of the shipping container; this procedure may damage the equipment.

- (1) Remove the nails from the wooden shipping container and remove the cover.
- (2) Carefully lift the fiberboard cartons from the wooden shipping container.
- (3) Remove the technical manuals and open the carton by slitting the top

along three edges; permit the fourth edge to act as a hinge.

- (4) Remove the corrugated top liner and folded corrugated end liners.
- (5) Carefully lift the distributor-transmitter and wooden shipping base out of the fiberboard carton.
- (6) Remove the machine screws and flat washers that hold the equipment to the wooden shipping base. Save the wooden shipping base, screws, and washers.
- (7) Remove the four rubber bumpers from the envelope taped to the distributor-transmitter and insert them into the holes provided in the bottom of the base frame.

10. Checking Unpacked Equipment

a. Check the condition of the equipment to make sure it has not been damaged during shipment. Check the dust cover for dents, cracks, or other damage which would indicate rough handling.

b. Check the equipment against the master packing list to make sure that all component parts and spare parts are present and in good condition. If no packing list accompanies the equipment, the table of components (par. 5) may be used as a general checklist.

c. If the equipment does not check with the packing lists, or if any damage is noted, fill out and forward DD Form 6 according to instructions in paragraph 2.

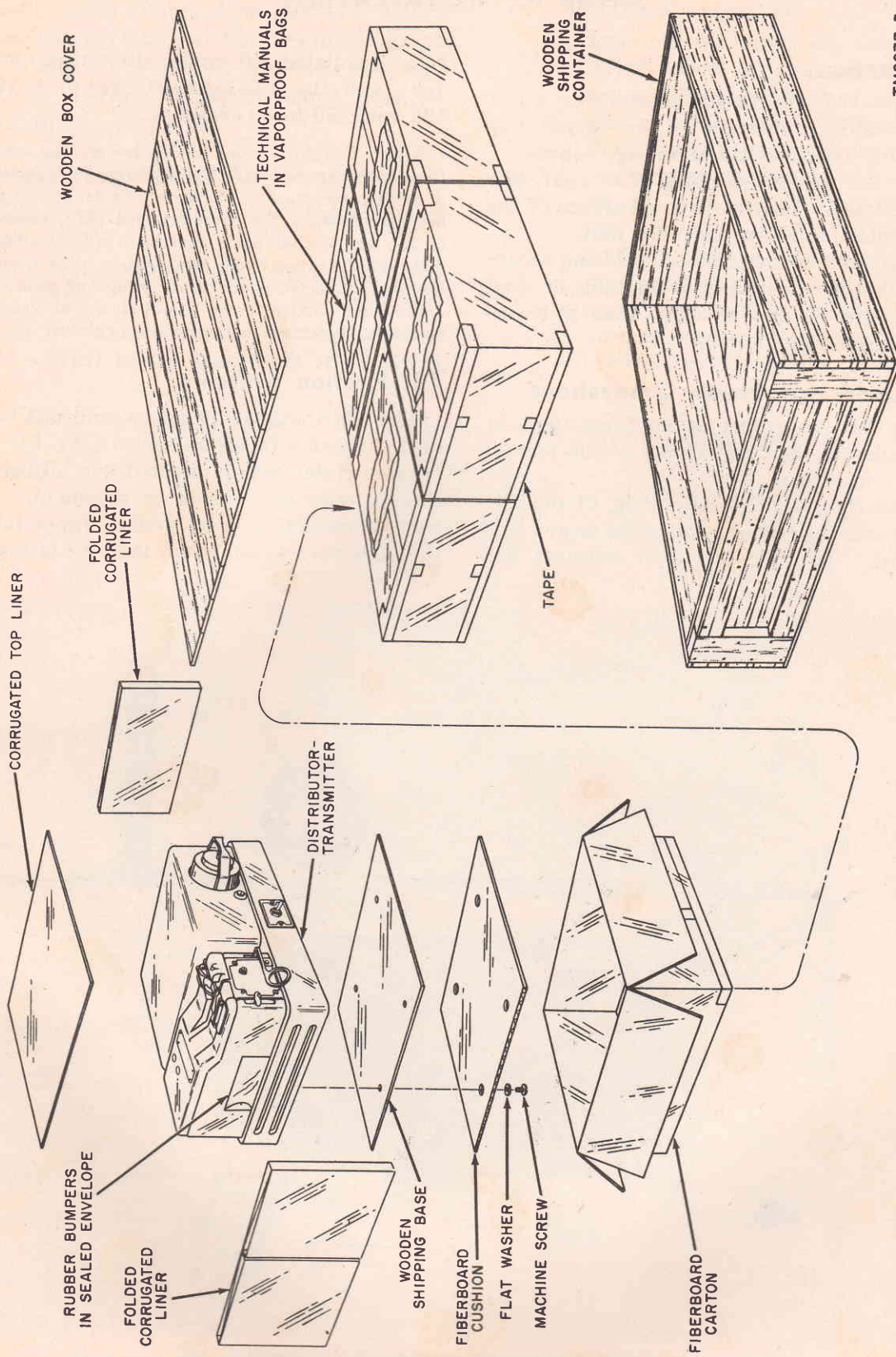

TM2277-3

Figure 3. Distributor-transmitter packaged for shipment.

Section II. INSTALLATION

11. Mounting

a. Place the distributor-transmitter on a shelf or table convenient to the signal line terminating jack and an ac voltage source.

b. Use the wooden shipping base (par. 9b) as a template and mark the top surface of the shelf or table used to support the unit.

c. Drill holes in the table or shelf and secure the distributor-transmitter to the table or shelf with the screws and washers that were removed in paragraph 9b (6).

12. Ground and Power Connections

a. See that the proper power fuses (par. 5) are installed in the fuse holders at the rear of the base (fig. 4).

b. Move the POWER switch (fig. 6) to OFF.

c. Connect the power cord to the power supply outlet. The TT-122A/FG requires 115

volts, regulated, 60 cycles alternating current (ac) and the TT-123A/FG requires 105 to 125 volts, 50 to 60 cycles ac.

Note. The third prong on the power plug completes the ground connection when the plug is inserted into a mating receptacle. If the available ac outlet will not accommodate the three-pronged plug, remove one of the screws that holds the third prong to the plug and turn the prong 90° to the right or left. Disconnect the lead connected to the third prong and connect it to a grounded portion of the ac outlet, a cold water pipe, or similar low-resistance ground connection.

13. Friction Clutch

The distributor-transmitter camshaft is powered through a friction clutch (2, fig. 9). This friction clutch was lubricated and adjusted by the manufacturer prior to shipment. However, it should be checked for proper lubrication and adjustment when the unit is installed

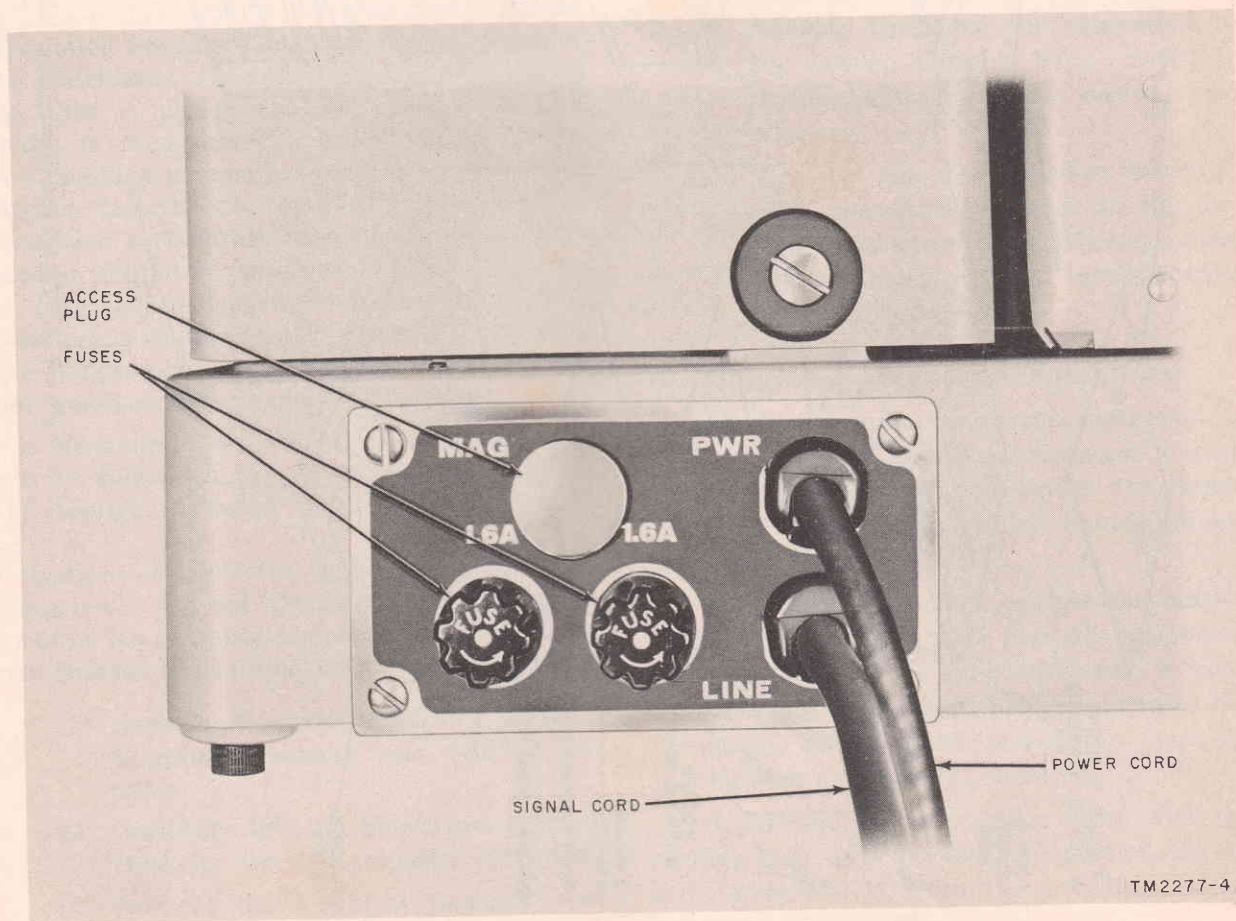

Figure 4. Teletypewriter Distributor-Transmitter TT-123A/FG, rear view.

to make sure that these conditions have not changed during shipment or storage. Lubricate the friction clutch as directed in paragraph 34d. Turn the POWER switch to ON and check the friction clutch adjustment as described in paragraph 57.

14. Operating Speed Adjustment

a. *Checking and Adjusting Motor Speed (TT-123A/FG).*

- (1) Move the POWER switch (fig. 6) to ON.
- (2) Strike the 180 vibrations per second (vps) tuning fork (part of TE-50-B,

par. 26a) gently against your hand to set it into vibration.

- (3) Look at the spots on the rotating target wheel of the series-governed motor (fig. 5) through the vibrating shutter on the end of the tuning fork. If the spots appear stationary, no adjustment is necessary. If the spots are moving clockwise, pull the end of the adjusting worm outward, and hold it until the clockwise motion of the target spots has stopped. If the spots are moving counterclockwise, push the ends of the adjusting worm inward until the motion of the target

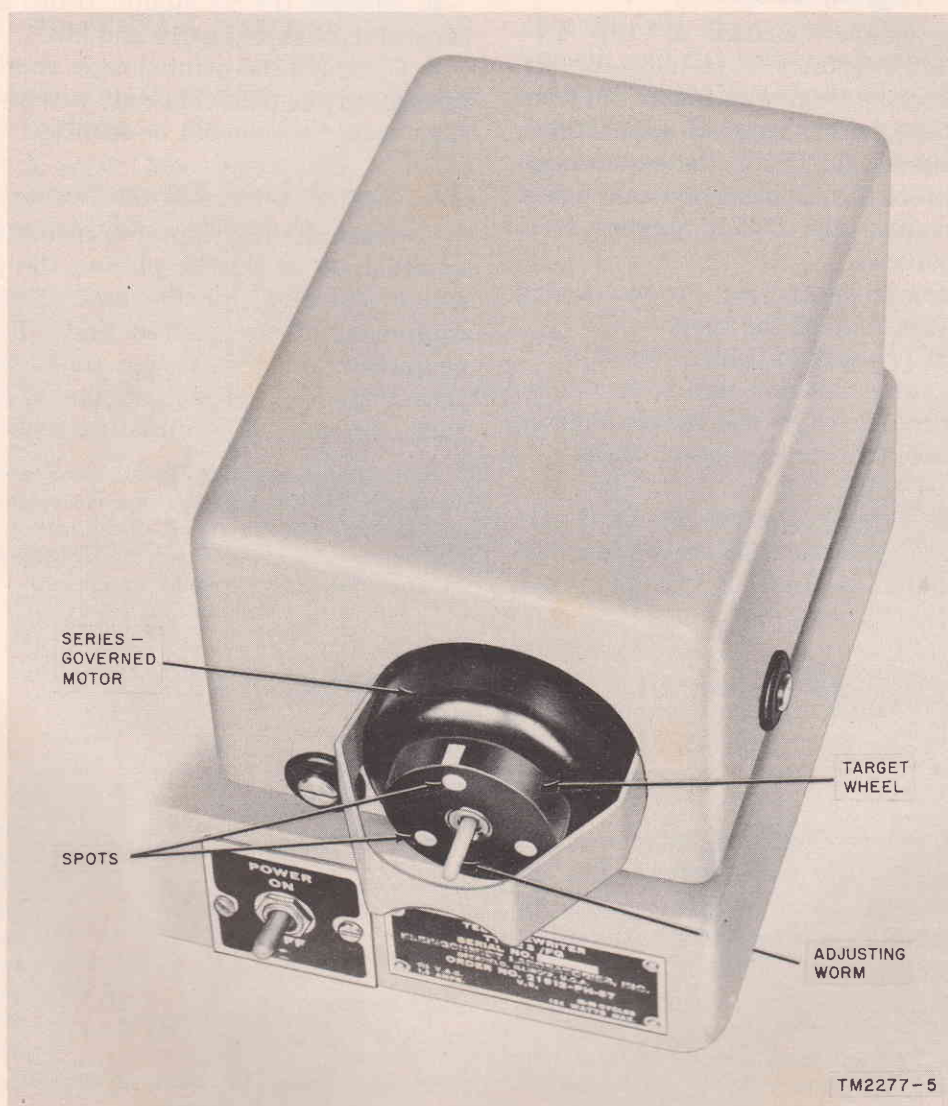

Figure 5. Motor speed control (TT-123A/FG).

spots has stopped. The motor now is set at its operating speed of 3,600 revolutions per minute (rpm).

(4) Move the POWER switch to OFF.

b. Changing Distributor-Transmitter Operating Speed. The operating speed of the distributor-transmitter is controlled by the drive gear set (1, fig. 9). The equipment is shipped with a 368.1 operations-per-minute (opm), 60 words-per-minute (wpm) drive gear set installed. A drive gear set for 600 opm (100 wpm) operation is mounted on studs under the dust cover. To change the operating speed of the distributor-transmitter follow the procedure described in paragraph 89b.

15. Clutch Magnet Control

The clutch magnet circuit of the TT-122A/FG and TT-123A/FG is normally energized by the same ac power source that operates the motor. In some special applications, it may be necessary to control the clutch magnet from an external equipment and a dc power source. To control the clutch magnet from an external source—

a. Use a screwdriver and pry the access plug (fig. 4) from the rear of the base.

b. Remove the base plate (par. 104a(2)).

c. Feed the two-conductor cord from the external equipment through the access hole in the base casting to terminal board TB2 (50, fig. 61).

d. Remove and tape separately the RED wire from terminal 1 and the GRN wire from terminal 2 of terminal board TB2 (fig. 47 or 48).

e. Attach one wire of the two conductor cord to terminal 1 of TB2 and the second wire to terminal 2 of TB2.

f. Replace the base plate.

g. Connect a 500-ohm, 10-watt resistor (for 48-volt dc operation) or a 1,700-ohm, 10-watt resistor (for 120-volt dc operation) in series with the cord from the external control equipment and the distributor-transmitter clutch magnet.

16. Local Testing

a. Insert the signal LINE cord of the distributor-transmitter into the receiving circuit of a teletypewriter page printer or reperforator equipped to supply current to the signal line.

b. Operate the distributor-transmitter as described in paragraphs 19 and 20.

c. Compare the printed copy received on the teletypewriter receiving unit with the test message sent; they should be identical.

17. Signal Line Connections

Connect the distributor-transmitter into the external signal line by placing the plug of the signal line cord into the jack of the terminal equipment of the desired line. The terminal equipment may be a line unit, switchboard, jack box, Telegraph Terminal TH-5/TG or some similar line-terminating device.

Note. Teletypewriter Distributor-Transmitters TT-122A/FG and TT-123A/FG are not equipped to supply line current for the signal line. Current for this circuit must be supplied from the distant teletypewriter or from the local terminal equipment.

Section III. OPERATING PROCEDURES

18. Controls (fig. 6)

The following chart lists the controls used to operate the distributor-transmitter. The operator must become familiar with the location and function of each control before attempting to operate the equipment.

Control	Location	Function
Stop-start lever	At left front side of distributor-transmitter cover.	START position allows messages to be transmitted.

Control	Location	Function
		STOP position stops transmission.
		FEED RE-TRACT position allows tape to be fed into the distributor transmitter.
Tight-tape lever	In front of distributor-transmitter.	When tape becomes tight, lever stops

Control	Location	Function
Tape-out lever	Under tape cover.	transmission. Slack in tape allows transmission. When end of tape is reached, the lever is permitted to rise and stop transmission.
POWER switch	Center front of base frame.	ON position connects ac input. OFF position disconnects ac input.

19. Starting and Testing Procedure

a. Move the POWER switch to the ON position.

b. Move the stop-start lever to the FEED RETRACT position.

c. Insert a paper tape perforated with the test message (e below) under the tape cover and line up the first letter or symbol of the

message opposite the START arrow on the top cover of the distributor-transmitter. (The design of the tape transmitter permits the tape to be inserted without raising the tape cover.)

d. Move the stop-start lever to the STOP position. Be sure that the feed holes in the paper tape engage the pins in the feed claw.

e. Raise the stop-start lever to the START position and send at least five copies of the following message: LTRS, THE QUICK BROWN FOX JUMPED OVER THE LAZY DOG'S BACK, LINE FEED, FIGS, 12345678 90-\$!&'()"/:;?.,

f. Be sure that the message tape moves into the tape transmitter smoothly without binding. Check the message tape after it has passed through the tape transmitter; it should be smooth and flat with no distortion of the code holes or elongation of the feed holes.

g. While the tape transmitter is sending a message, each of the following actions should stop transmission.

- (1) Raising the tight-tape lever (fig. 6).

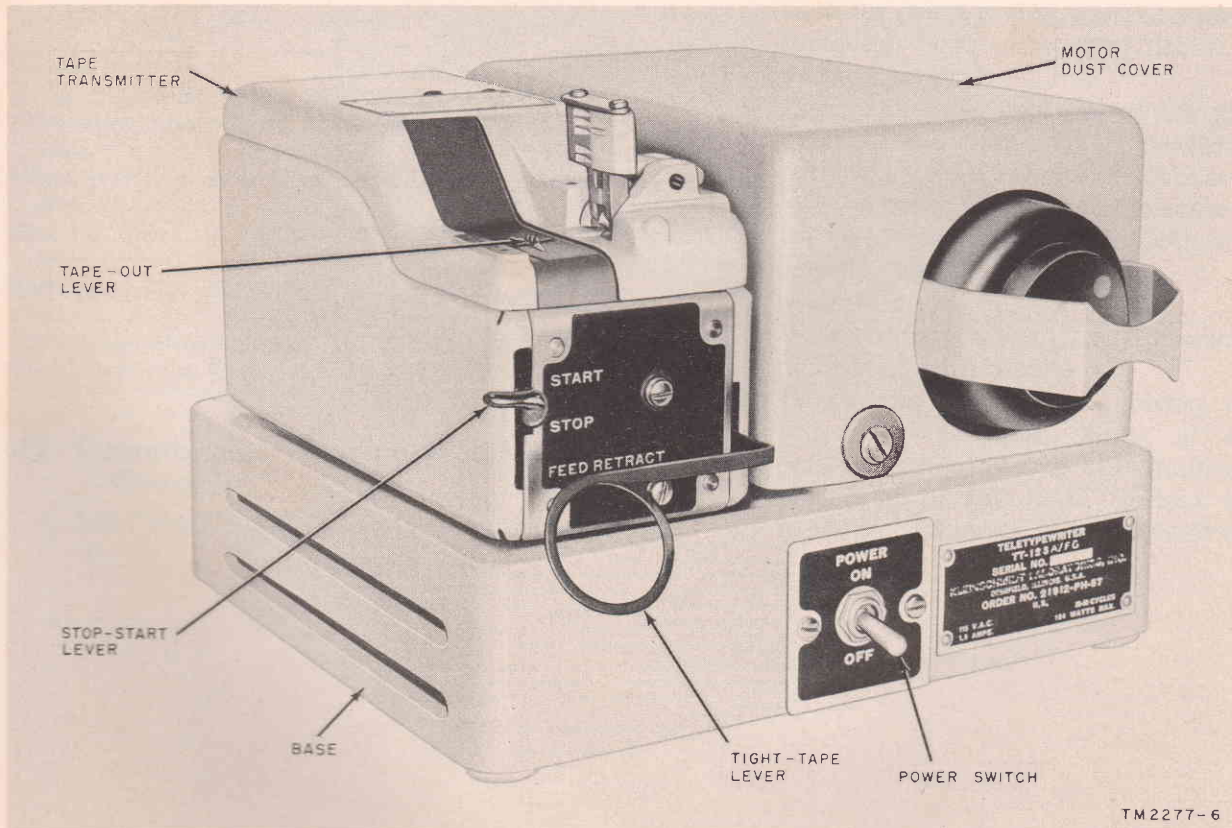

Figure 6. Distributor-transmitter controls.

- (2) Moving the stop-start lever to the STOP or FEED RETRACT position.
- (3) Allowing the end of the message tape to pass over the tape-out lever.
- (4) Moving the POWER switch to the OFF position.

20. Stopping Procedure

To shut down the distributor-transmitter to traffic, move the POWER switch to OFF. The motor should stop and all power except signal line current will be removed from the unit.

CHAPTER 3

ORGANIZATIONAL MAINTENANCE

Section I. FIRST ECHELON MAINTENANCE

21. Scope of Operator's Maintenance

Operator's maintenance is limited to cleaning and inspection of external parts, inspection of electrical connections, wiring, and insulation, and the performing of operational checks to determine if the machine is operating properly.

22. Materials Required for Operator's Maintenance

The following maintenance materials are required for operator's maintenance:

Item	Stock No.
Orangestick	5120-408-4036 (Fed)
Brush, toothbrush style	53-B121610 (QMC)
Cheesecloth, bleached, 36 in. wide.	6Z1989 (SigC)
Cloth, crocus, 9 in. x 11 in. sheets.	42-C-20420-50 (Ord C)
Cleaning compound, liquid form.	7930-395-9542 (Fed)
Sandpaper, flint, No. 0000, 9 in. x 10 in.	42-P-1154-10 (Ord C)
Solvent, dry cleaning (SD)	51-S-4385-1 (QMC)
Brush, sash, 1 x 5/8 in.	38-4567.300.200 (CE)

23. Operator First Echelon Maintenance Checklist

a. DA Form 11-252 (fig. 7) is the preventive

maintenance checklist to be used by the operator.

b. Items not applicable to Teletypewriter Distributor-Transmitters, TT-122A/FG or TT-123A/FG are lined out in figure 7. References to the ITEM block in this figure are to paragraphs that contain additional maintenance information pertinent to the particular item.

24. Operator's Maintenance

a. *Covers.*

- (1) Inspect the dust covers thoroughly. Look for dents, cracks, marred painted surfaces, rust, corrosion, loose or missing screws.
- (2) Clean the outer surfaces of the dust cover with a cloth slightly moistened with water. To remove oil, grease or gummy stains on the outer surface of the dust cover, moisten the cloth with solvent (SD).

b. *External Wiring.*

- (1) Wipe the external wiring with a cloth dampened with water.
- (2) Check the wiring for cracks, deteriorated insulation, kinks, or excessive strain due to the improper placement of the unit. Adjust the machine position to relieve the strain.

MAINTENANCE CHECK LIST FOR SIGNAL EQUIPMENT TELETYPEWRITER (AR 750-625)		
EQUIPMENT NOMENCLATURE TELETYPEWRITER DISTRIBUTOR-TRANSMITTER TT-122A1FG		
EQUIPMENT SERIAL NUMBER 612		
INSTRUCTIONS		
<p>This form may be used for a period of one month by using the correct dates and weeks of the month. It is to be used as a Preventive Maintenance check list for Signal equipment in actual use, or for a check on equipment prior to issue.</p> <p>1. For detailed Preventive Maintenance instructions see:</p> <ul style="list-style-type: none"> a. The Technical Manual (in TM 11 series) for the equipment. (See DA Pamphlet Number 310-4) b. The Supply Bulletin (SB 11-100 series) for the equipment. (See DA Pamphlet Number 310-4) c. The Department of the Army Lubrication Order. (See DA Pamphlet Number 310-4) <p>2. The following action will be taken by either the Communications Officer/Chief for 1st echelon, or the Inspector for higher echelon:</p> <ul style="list-style-type: none"> a. Enter Equipment Nomenclature and Serial Number. b. Strike out items that do not apply to the equipment. <p>3. Operator/Inspector will enter in the columns entitled CONDITION, on the proper line, a notation regarding the condition, using symbols specified under LEGEND.</p> <p>4. After operator completes each daily inspection he will initial over the appropriate dates under "Daily Condition for Month", then return form to his supervisor.</p>		
TYPE OF INSPECTION		
OPERATOR	DATE	SIGNATURE
✓	7 DEC 57	<i>Joe Danks</i>

FOLD

DA FORM 11-252
MAY 57

REPLACES DA FORMS 11-282, 1 OCT 55; 11-283, 11-262, AND 11-263; WHICH ARE OBSOLETE.

U. S. GOVERNMENT PRINTING OFFICE: 1957 O-427033 4

TM2277-7

Figure 7. DA Form 11-252.

LEGEND for marking conditions: Satisfactory, Adjustment, Repair or Replacement required, X, Defect corrected, (X).		DAILY CONDITION FOR MONTH OF DECEMBER 1957																		
		DAILY CONDITION FOR MONTH OF DECEMBER 1957																		
NO.	DAILY ITEM	CONDITION EACH WEEK												CONDITION						
		1ST	2D	3D	4TH	5TH	6TH	7TH	8TH	9TH	10TH	11TH	12TH	13TH	14TH	15TH	16TH	2D ECH.	3D ECH.	
1.	CHECK FOR NORMAL OPERATION OF EQUIPMENT. BE ALERT FOR ANY UNUSUAL PERFORMANCE OR CONDITION. PAR. 19																			
2.	CLEAN DIRT, OIL AND MOISTURE FROM THE EXPOSED SURFACES OF THE TELETYPEWRITER AND COVER.																			
3.	INSPECT ALL EXTERNAL SWITCHES FOR PROPER MECHANICAL ACTION. FREEDOM OF MOVEMENT AND POSITIVE ACTION.																			
4.	EMPTY SHAD BOXES ON REPERFORATORS AND CHECK OPERATION THAT SHAD BOXES ARE FREE OF OBSTRUCTIONS.																			
WEEKLY		1ST	2D	3D	4TH	5TH	6TH	7TH	8TH	9TH	10TH	11TH	12TH	13TH	14TH	15TH	16TH	2D ECH.	3D ECH.	
5.	CLEAN THE INSIDE AND OUTSIDE OF FRAME CASES—INSPECT FOR BROKEN OR MISSING LATCHES, HINGES AND EQUIPMENT SUPPORTS OR BRACKETS.																			
6.	INSPECT EXTERNAL CABLES AND CORDS FOR CUTS OR COILED JACKETS, FRAYING, BAD BRUISES OR KINKS AND BROKEN PLUGS OR CONNECTORS.																			
7.	INSPECT EXTERNAL BINDING POSTS AND TERMINAL BLOCKS FOR CRACKS, BREAKS, LOOSE SCREWS, LOOSE CONNECTIONS AND MOUNTINGS.																			
ADDITIONAL ITEMS FOR 2D AND 3D ECHELON INSPECTIONS																				
8.	INSPECT FOR AND TIGHTEN ANY LOOSE SCREWS, NUTS OR BOLTS ON THE COVER OR TIGHTEN GAGES—CHECK FOR BROKEN LATCHES, LATCHES, HINGES, HOOKS AND MOUNTINGS.																			
9.	INSPECT COVER WINDOWS FOR CRACKS, BREAKAGE OR OTHER DAMAGE.																			
10.	INSPECT ALL ELECTRICAL PLUGS AND RECEPTACLES FOR BREAKAGE, POOR SEATING, PROPER CONTACT, CORROSION AND GREASE OR OIL DEPOSITS—CLEANUP REQUIRED.																			
11.	INSPECT CABLES, CORDS AND WIRING FOR CUT OR LOOSE JACKETS, KINKS, BUBBLES OR FRAYING.																			
12.	INSPECT BINDING POSTS AND TERMINAL BLOCKS FOR CRACKS, BREAKS, DIRT AND LOOSE CONNECTIONS.																			
13.	INSPECT FOR LOOSE MOUNTING SCREWS AND NUTS ON PARTS OR BRACKETS.																			
14.	INSPECT ALL SWITCHES FOR BINDING, FREEDOM OF MOVEMENT AND POSITIVE ACTION.																			
15.	INSPECT MOTOR AND GOVERNOR FOR WORK, BRUSHES AND CONTACTS—CLEANUP REQUIRED.																			
ADDITIONAL ITEMS FOR 2D AND 3D ECHELON INSPECTIONS																				
16.	CLEAN THE TYPE PALLET.																			
17.	CLEAN THE KEYPADS AND CHECK FOR BROKEN, MISSING, LOOSE, OR ILLEGIBLE KEYS.																			
18.	CLEAN INK FEED TUBES AND INK WELLS—REPLACE INKING FELT OR TYPING RIBBON IF REQUIRED.																			
19.	INSPECT GENERAL CONDITION OF LUBRICATION AND LUBRICATE AS REQUIRED IN ACCORDANCE WITH APPLICABLE LUBRICATION INSTRUCTIONS.																			
20.	CLEAN EXCESS OIL, GREASE AND DIRT FROM MECHANICAL ASSEMBLIES, GEARS, SHAFTS, FRAMES, ETC.																			
21.	PERFORM ANY ADJUSTMENT REQUIRED AS A RESULT OF CLEANING, LUBRICATION OR NORMAL WEAR.																			
22.	INSPECT FOR FREEDOM OF MOVEMENT OF ALL MOVING PARTS; IDENTIFY AND REPORT ON TORN STRIPS, GEARS, CAMS, SPRINGS, CLUTCHES, SUBMITS AND BEARINGS.																			
23.	OPERATE EACH KEY AND CHECK THE FUNCTIONAL RESPONSE.																			
24.	CHECK THAT THE PRINTING ON PAGE PRINTERS IS IN ALIGNMENT AND FULLY PRINTED—CHECK THAT THE CHARACTERS ARE EVENLY SPACED—PRINTED ON TYPING REPERFORATORS.																			
25.	CHECK THE TUBE OF TYPING AND NON TYPING REPERFORATORS AND REPERFORATORS FOR CLEAN FUNCTIONING OF GEMS AND FEED HOLES.																			
IF DEFICIENCIES NOTED ARE NOT CORRECTED DURING THE INSPECTION, INDICATE ACTION TAKEN FOR CORRECTION. (Continue on page 4, if more space is needed)																				
PLUS ON SIGNAL CORD BROKEN, REPORTED TO MAINTENANCE PERSONNEL																				

Figure 7—Continued

Section II. SECOND ECHELON MAINTENANCE

25. Scope of Technician's Maintenance

This level of maintenance must be performed by qualified technicians. It includes all maintenance that can be performed with the tools available to the maintenance technician provided that part replacement, other than the replacement of running spares, is not required. Partial disassembly required to perform any of the items of maintenance described in this section are within the scope of the second echelon maintenance technician.

26. Tools and Materials Required

a. Tools. No tools are supplied with Teletypewriter Distributor-Transmitter TT-122A/FG or TT-123A/FG. Tool Equipment TE-50-B and Multimeter ME-77/U are required for maintenance at organizational level. Tool Equipments TE-50 and TE-50-A do not include some special wrenches and gages included in TE-50-B. Organizations that have the TE-50 or TE-50-A should requisition the additional tools in accordance with appropriate supply bulletins.

b. Maintenance Materials.

- (1) Materials necessary for maintenance at organizational levels are included in Tool Equipment TE-50-B with the exception of a liquid cleaning agent and an anti-seize compound. Mechanical assemblies should be cleaned with solvent (SD). Gasoline never should be used as a cleaning fluid. When solvent (SD) is not immediately available, Fuel oil, diesel (DF-A), Federal stock No. 9140-286-5282, may be used as a temporary substitute. Cleaning Compound should be used to clean electrical contact surfaces.

Warning: Repeated or prolonged breathing of cleaning compound is dangerous. Make sure adequate ventilation is provided. Cleaning compound is flammable; do not use near a flame.

- (2) The distributor-transmitters contain aluminum and magnesium castings. When steel screws are placed in such

castings, tendency exists for seizure between the screws and the castings unless the screws are treated first with Anti-seize Compound 52-2724. 5000.080 (CE). Screws are given this treatment at the factory when the machines are assembled. Whenever machines are disassembled after having been in use, the coating should be renewed by maintenance personnel to insure that there will be no difficulty at the time of the next disassembly. The recommended anti-seize compound may be requisitioned through regular supply channels.

27. General Preventive Maintenance Techniques

Most preventive maintenance techniques pertain to specific areas of preventive maintenance, such as lubrication; however, the following general instructions should be helpful.

a. Use No. 0000 sandpaper to remove corrosion.

b. Use a clean, dry, lint-free cloth or a dry brush for most cleaning purposes.

- (1) When necessary, use a cloth or a brush moistened with solvent (SD) to clean parts (except electrical contacts). Wipe the solvent and dirt from the part with a clean dry cloth.

- (2) A flushing action normally is best when cleaning electrical contacts. Dip an orangestick in an approved contact cleaning compound and allow the liquid to drip from the stick through the contacts. Rub the contact surfaces with the wet orangestick to loosen dirt or gummy deposits. Allow the contacts to dry by evaporation and then polish with the contact burnisher.

c. If available, vacuum cleaning equipment is suitable for removal of loose dust, paper lint, and dirt.

28. Technician's Maintenance

This level of maintenance must be performed by qualified technicians. To service a distribu-

LEGEND for marking conditions:
Satisfactory, Y,
Adjustment, Repair or Replacement required, X,
Defect corrected, (X).

DAILY CONDITION FOR MONTH OF
December 1957

NO.	DAILY ITEM	CONDITION EACH WEEK							2D 3D ECH	CONDITION
		1ST	2D	3D	4TH	5TH	6TH	7TH		
1.	CHECK FOR NORMAL OPERATION OF EQUIPMENT. BE ALERT FOR ANY UNUSUAL PERFORMANCE OR CONDITION. PAR. 19									
2.	CLEAN DIRT, OIL AND MOISTURE FROM THE EXPOSED SURFACES OF THE TELETYPEWRITER AND COVER.									
3.	INSPECT ALL EXTERNAL SWITCHES FOR PROPER MECHANICAL ACTION, FREEDOM OF MOVEMENT AND POSITIVE ACTION.									
4.	EMPTY SHAB BOXES ON REPERATORS AND CHECK BY OPERATION THAT SHAB BOXES ARE FREE OF OBSTRUCTIONS.									
WEEKLY										
5.	CLEAN THE INSIDE AND OUTSIDE OF FRAMING CASES. INSPECT FOR BROKEN OR MISSING LATCHES, HANDLES AND EQUIPMENT SUPPORTS OR BRACKETS.									
6.	INSPECT EXTERNAL CABLES AND CORDS FOR CUTS OR GOUGED JACKETS, FRAYING, BAD BRUISES OR KINKS AND BROKEN PLUGS OR CONNECTORS.									
7.	INSPECT EXTERNAL BINDING POSTS AND TERMINAL BLOCKS FOR CRACKS, BREAKS, DRIFT, LOOSE SCREWS, LOOSE CONNECTIONS AND MOUNTINGS.									
ADDITIONAL ITEMS FOR 2D AND 3D ECHELON INSPECTIONS										
8.	INSPECT FOR, AND TIGHTEN, ANY LOOSE SCREWS, NUTS OR BOLTS ON THE COVER OR FRAME. CHECK FOR BROKEN CATCHES, LATCHES, HANDLES, HINGES AND MOUNTINGS.									
9.	INSPECT COVER HINGES FOR BROKEN OR CRACKS ON OTHER BRACKETS.									
10.	INSPECT ALL ELECTRICAL PLUGS AND RECEPTACLES FOR BREAKAGE, FIRM SEATING, PROPER CONTACT, CORROSION AND GREASE OR OIL DEPOSITS. CLEAN IF REQUIRED.									
11.	INSPECT CABLES, CORDS AND WIRING FOR CUT OR GOUGED JACKETING, KINKS, BAD BRUISES OR FRAYING.									
12.	INSPECT BINDING POSTS AND TERMINAL BLOCKS FOR CRACKS, BREAKS, DIRT AND LOOSE CONNECTIONS.									
13.	INSPECT FOR LOOSE MOUNTING SCREWS AND NUTS ON PARTS OR BRACKETS.									
14.	INSPECT ALL SWITCHES FOR BINDING, FREEDOM OF MOVEMENT AND POSITIVE ACTION.									
15.	INSPECT MOTOR AND GOVERNOR FOR WORN BRUSHES AND CONTACTS. CLEAN IF REQUIRED. PAR. 28d									
ADDITIONAL ITEMS FOR 2D AND 3D ECHELON INSPECTIONS										
16.	CLEAN THE TYPE PALLET.									
17.	CLEAN THE KEYS AND CHECK FOR BROKEN MISSING LOGS OR TELETYPE KEYS.									
18.	CLEAN INK FEED TUBES AND INK WELLS. REPLACE INKING FELT OR SPRING WAGON IF REQUIRED.									
19.	INSPECT GENERAL CONDITION OF LUBRICATION AND LUBRICATE AS REQUIRED IN ACCORDANCE WITH APPLICABLE LUBRICATION INSTRUCTIONS. PAR. 34									
20.	CLEAN EXCESS OIL, GREASE AND DIRT FROM MECHANICAL ASSEMBLAGES, GEARS, SHAFTS, FRAMES, ETC.									
21.	PERFORM ANY ADJUSTMENT REQUIRED AS A RESULT OF CLEANING, LUBRICATION OR NORMAL WEAR. PAR. 40-57									
22.	INSPECT FOR FREE MOVEMENT OF ALL MOVING PARTS: BENT, BROKEN, DISTORTED OR WORN SHAFTS, GEARS, CAMS, SPRINGS, CLUTCHES, BUSHINGS AND BEARINGS.									
23.	OPERATE EACH KEY AND CHECK THE FUNCTIONAL RESPONSE.									
24.	CHECK THAT THE PRINTING ON PAGE PRINTERS IS IN ALIGNMENT AND PULVERIZED. CHECK THAT THE CHARACTERS ARE EVENLY SPACED PRINTED ON THE REPERATORS.									
25.	CHECK THE TARE OF TANKS AND NON-TANK REPERATORS AND PERFORMERS FOR CLEAN PUNCHING OF CODE AND FEED HOLES.									
IF DEFICIENCIES NOTED ARE NOT CORRECTED DURING THE INSPECTION, INDICATE ACTION TAKEN FOR CORRECTION. (Continue on page 4, if more space is needed)										
PLUS ON SIGNAL CORD BROKEN. PLUS REPLACED.										

Figure 8. DA Form 11-252, pages 2 and 8.

tor-transmitter, take the equipment out of service and partially disassemble it (a below). Refer to Form 11-252 (fig. 8) for a listing of maintenance items. The listed items are partially or totally applicable to this equipment. References in the ITEM blocks refer to paragraphs in the text which contain additional maintenance information.

a. Procedure.

- (1) Remove the power cord from the ac outlet. Disconnect the signal line.
- (2) Remove the three shoulder screws that hold the motor dust cover to the base frame; remove the motor dust cover.
- (3) Remove the distributor-transmitter from the base frame (par. 93a).
- (4) Remove the bottom plate from the base frame (par. 89a(2)).

b. Preventive Maintenance for Base.

- (1) Clean the base thoroughly with a clean cloth. Wipe away all deposits of oil or grease that may have dropped from the mechanical assemblies. Use a cleaning brush to remove all loose dirt and paper lint from the electrical components mounted within the base. If grimy deposits on the base frame are difficult to remove with a dry cloth, moisten the cloth with solvent (SD).
- (2) Perform the preventive maintenance for cords, cables, wiring, terminal boards, and switches as described in e, f, and g below.

c. Preventive Maintenance for Distributor-Transmitter.

- (1) Inspect the unit for—
 - (a) Cracks and other damage to the distributor-transmitter covers and any mechanical linkages.
 - (b) Loose, missing, or broken screws, nuts, bolts, fastenings, and electrical connections; frayed or broken wire insulation, and oil-soaked wiring or insulation.
 - (c) Missing, broken, or distorted levers, pawls, latches, springs, and bearings. Check to see that all parts move freely.
 - (d) Worn, burned, or dirty contacts and

insulation in the transmitting contact assembly.

Note. Do not tighten parts that require clearance or tension adjustments. Tighten all screws and bolts that are not part of an adjustment.

- (2) Clean the tape transmitter as follows:
 - (a) Blow out or brush away dust and debris that may have accumulated in the transmitter mechanism and around the mechanical levers.
 - (b) Burnish contacts if they are dirty, built up, or pitted.
- (3) Lubricate the tape transmitter as described in paragraphs 29 through 34. Remove excess lubricant.

d. Preventive Maintenance for Motor.

- (1) The motor should turn freely and quietly with very little end play when turned by hand. Check the motor for evidence of overheating. This may be indicated by discoloration or by an odor of burned insulating material. Check the governor (TT-123A/FG), governor cover, and target of the governed motor for looseness.
- (2) Clean the exterior of the motor. Remove all dust, dirt, grease, and corrosion from the outside of the motor. Check to see that the governor (TT-123A/FG) is clean and that the wires leading to the motor are intact and clean.
- (3) Apply lubricant, as necessary, to the motor and to the governor lubrication points of the TT-123A/FG (par. 34e).

e. Preventive Maintenance for Cords, Cables, and Wiring.

- (1) Check all visible wiring for cracked or deteriorated insulation, frayed or cut insulation at connecting points, kinks, and strain caused by improper placement.
- (2) Tighten loose fasteners, clamps, and wiring connections. Repair loose or broken connections. Remove corrosion, rust, dirt, and dust from ground connections. Be sure that the outer insulating cover on cords and cables is wiped clean. Never use oil or solvent (SD) on rubber insulation.

- (3) Adjust the wiring so that it does not interfere with operation of mechanical parts. It may be necessary to resolder certain connections or to replace some wiring or conductors when they become worn or damaged.

f. Preventive Maintenance for Terminal Boards.

- (1) Terminal boards used as distributing points for electrical circuits usually are made of a strip of insulating material and one or more types of electrical connectors. These devices may be either solder- or screw-type terminals, contact springs, or contact lugs. They normally require little preventive maintenance unless the wiring is changed. Inspect the terminal boards for cracks, breakage, and loose connecting or mounting screws. Examine the connections for mechanical defects (broken or stripped screws and threads), dirt, grease, and corrosion. Tighten loose screws, lugs, and mounting bolts. Use tools of the correct size. Be extremely careful not to strip the threads by exerting too much force. Solder loose or broken connections.
- (2) Wipe off any moisture with a clean cloth and brush the dust and dirt from the terminal board with a clean dry brush. When necessary, terminal boards may be cleaned with a cloth moistened with solvent (SD); however, be careful that the solvent (SD) does not come in contact with the in-

sulation of any of the wires leading to the terminal board. Remove and clean corroded or loose connections. Use cleaning compound to clean electrical contacts on all connecting devices.

g. Preventive Maintenance for Switches.

- (1) Inspect the mechanical action of the POWER switch. Look for dirt or corrosion. Operate the switch to see that the operating lever moves freely. Tighten loose screws, lugs, and mounting parts. Remove loose connections that are dirty or corroded, and clean them before they are tightened or soldered. Tighten switch connections and repair soldered connections.
- (2) Wipe off any moisture present. Carefully clean the exterior surfaces of the POWER and start-stop switches with a dry, stiff brush.

h. Reassembly and Performance Test.

- (1) Reassemble the distributor-transmitter as follows:
 - (a) Install the distributor-transmitter on the base frame (par. 93b).
 - (b) Replace the motor dust cover; secure it with the three shoulder screws.
 - (c) Replace the bottom plate on the base frame (par. 89c).
 - (d) Connect the power cord into the ac outlet from which it was removed.
 - (e) Insert the signal line plug into the appropriate line terminating device.
 - (f) Start and test the distributor-transmitter (par. 19).

Section III. LUBRICATION

29. General

Lubrication is the most important single item in a preventive maintenance program. Carefully follow lubrication instructions given in the subsequent paragraphs, using the lubricants indicated in the quantities recommended and at the correct time interval. The lubrication instructions for the TT-122A/FG and TT-123A/FG are identical except where indicated.

30. Recommended Lubricants

The recommended lubricants are—

- a. Oil, lubricating, Signal Corps stock No. 6G1325 (1 quart can).
- b. Grease, Signal Corps stock No. 6G650 (1 pound container).

31. Recommended Lubrication Schedule

The following chart shows the recommended intervals for checking the lubrication of dis-

tributor-transmitters. When checking, lubricate only those points that require lubrication. DO NOT OVERLUBRICATE.

Distributor-transmitter operating speeds (wpm)	Operating periods (number of days)			
	Up to 8 hours per day	8 to 12 hours per day	12 to 16 hours per day	16 to 24 hours per day
60	30	20	15	10
66	27	18	13	9
75	24	18	12	8
100	18	12	9	6

32. Preparation for Lubrication

To completely lubricate the distributor-transmitter, take it out of service and disassemble as outlined in *a* below. After lubrication, reassemble the distributor-transmitter and check the motor speed adjustment (par. 14a).

a. Disassembly. To disassemble the distributor-transmitter for lubrication, proceed as follows:

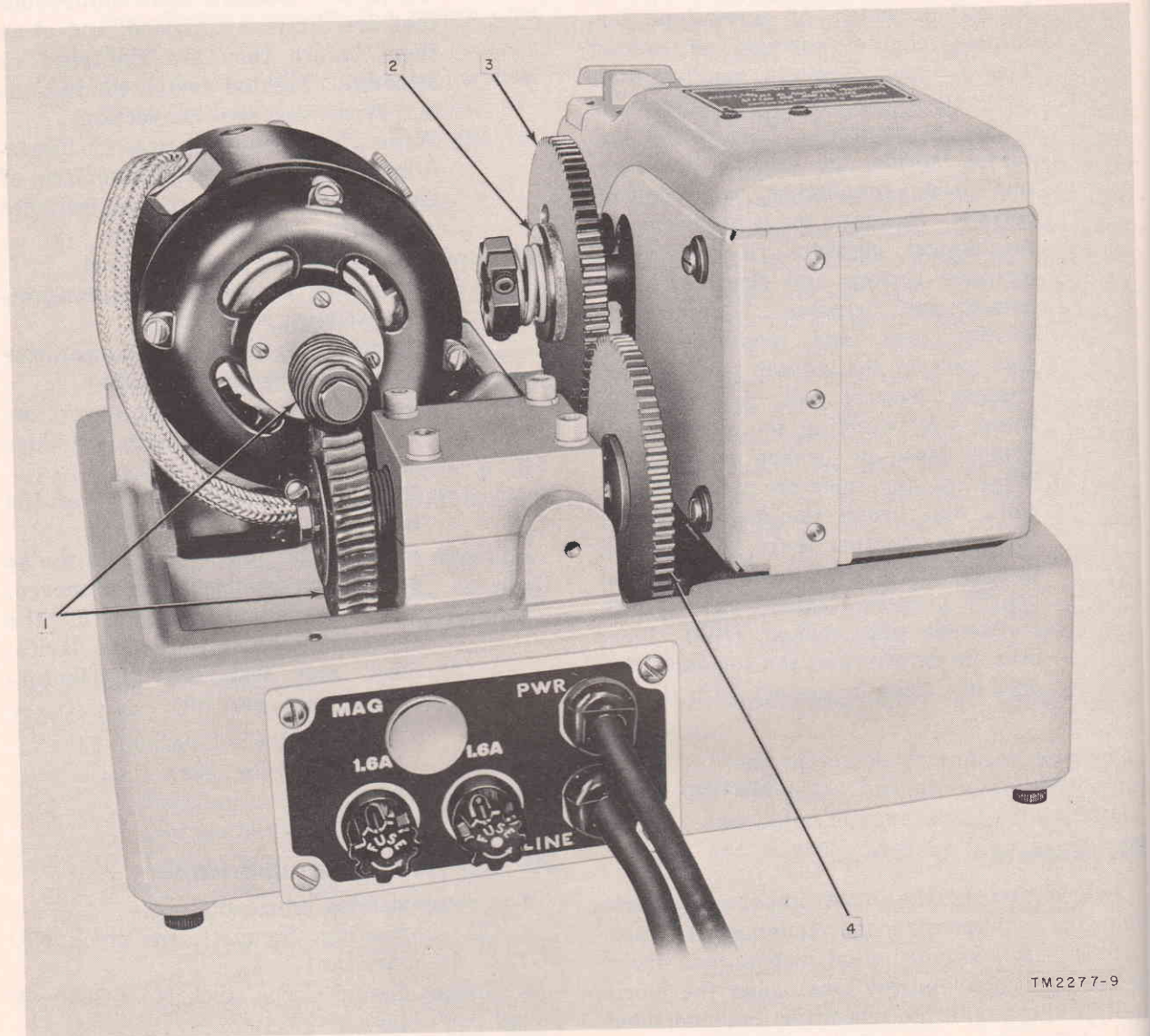

- 1 Drive gearset
- 2 Friction clutch

- 3 Distributor-transmitter driven gear
- 4 Distributor-transmitter driving gear

Figure 9. Distributor-transmitter showing lubrication points, rear view.

- (1) Disconnect the power and signal cords.
- (2) Remove the three shoulder screws that hold the motor dust cover to the base frame; remove the motor dust cover.
- (3) Remove the tape transmitter covers as described in paragraph 94a(1).
- (4) On the TT-123A/FG, remove the motor governor target and cover (par. 91a(5) and (6)).

b. Old Lubricants. Remove all old grease and oil with a clean, dry, lint-free cloth. Wrap the cloth around the end of a screwdriver or an orangestick to remove old lubricants from hard-to-reach places.

33. General Lubrication Instructions

a. Method of Applying Grease. Use a grease gun to apply grease to gears. Hold the nozzle

of the grease gun against the gear teeth at an angle of about 45°. Operate the handle until enough grease is ejected and, at the same time, turn the gear to form a continuous ribbon of grease.

b. Method of Applying Oil. To apply only 1 or 2 drops of oil, dip a piece of No. 22 wire approximately one-half inch into the oil and immediately touch it to the lubrication point to be oiled. This method prevents overlubrication. Where more oil is required, use the oiler supplied with Tool Equipment TE-50-B.

c. Preventing Corrosion. Apply only enough oil (except as otherwise indicated) to wet the rubbing surfaces. After the distributor-transmitter is completely lubricated, wipe off excess oil and any visible dirt.

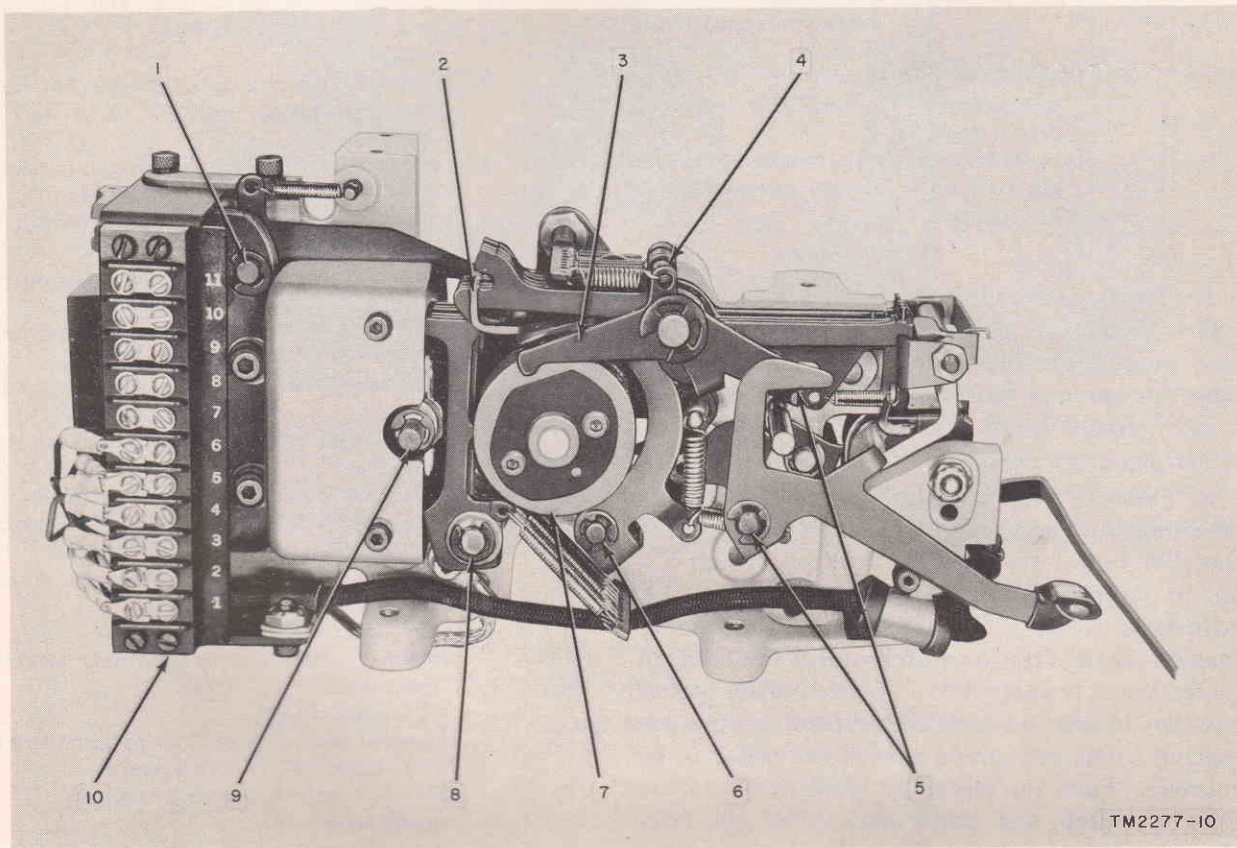

- | | | | |
|---|----------------------------|----|--|
| 1 | Clutch magnet armature | 6 | Tape feed lever |
| 2 | Selector lever comb | 7 | Distributor-transmitter camshaft |
| 3 | Tape feed retracting lever | 8 | Selector levers, bearing shoes, and flat washers |
| 4 | Code sensing lever | 9 | Transmitter contact bail pivot stud |
| 5 | Stop-start lever | 10 | Terminal board TB1 |

Figure 10. Right side of distributor-transmitter, showing lubrication points.

34. Detailed Lubrication Instructions

The points to be lubricated, the type of lubricant to be used, and the quantity to be applied are listed in the charts below. The item numbers are arranged according to the method of application so that the distributor-transmitter can be treated by one method or by one lubricant at a time in a systematic way. Item numbers shown in figures 9 through 13 for the parts to be lubricated correspond to item numbers listed in the charts.

a. Ball Bearings. All ball bearings in the distributor-transmitter are sealed and do not require lubrication.

b. Gears. Wipe old grease from gears with a clean, dry, lint-free cloth and apply fresh grease as follows:

Fig. No.	Item No.	Name of part	Method and quantity
9	1	Drive gearset.	Work grease around gears, cover gear teeth liberally.
9	3	Distributor-transmitter driven gear.	Apply grease sparingly around gear teeth.
9	4	Distributor-transmitter driving gear.	Apply grease sparingly around gear teeth.

c. Cams. Use a cloth moistened with solvent (SD) to remove all of the old lubricants and any dust or residue that might be present. Dry the surface thoroughly and apply a thin coat of grease to all cam lobes of the distributor-transmitter camshaft (7, fig. 10).

d. Friction Clutch. Apply 10 to 15 drops of oil along the periphery of felt friction plates of the distributor-transmitter friction clutch (2, fig. 9); apply oil sparingly to the spring and adjusting collar. Do not release the spring tension on the friction clutch unless the friction plates are extremely dry. To release the spring tension, loosen the machine screws in the adjusting collar enough to permit the collar to be rotated. Turn the motor by hand to rotate the friction clutch, and apply oil. After the friction clutch is oiled, set the adjusting collar to

give approximately the required spring tension and run the distribution-transmitter motor for about 5 minutes without transmitting. Then set the spring tension of the friction clutch (par. 57).

e. Moving Parts. Apply oil at the following places:

Fig. No.	Item No.	Name of part	Method and quantity
10	1	Clutch magnet armature.	1 or 2 drops at pivot and working end.
10	2	Selector lever comb.	1 or 2 drops at each comb slot.
10	3	Tape feed retracting lever.	1 or 2 drops at pivot and working end.
10	4	Code sensing levers.	Apply sparingly at pivot and working surfaces.
10	5	Stop-start lever.	1 or 2 drops at pivot and working points.
10	6	Tape feed lever.	1 or 2 drops at pivot and working points.
10	8	Selector levers, bearing shoes, and flat washers.	Apply sparingly to all rubbing and bearing surfaces.
10	9	Transmitter contact bail pivot stud.	2 or 3 drops between arm and pivot stud.
11	1	Tape-out lever.	1 or 2 drops at pivot and working points.
11	2	Tape feed claw.	1 or 2 drops at pivot and working points.
11	3	Stop-start lever detent.	1 or 2 drops at pivot and working points.
11	4	Lower switch bail lever.	1 or 2 drops at pivot and working points.
11	5	Tight-tape lever.	1 or 2 drops at pivot and working points.
11	6	Upper switch bail lever.	1 or 2 drops at pivot and working points.
12	1	Tape cover hinge.	1 or 2 drops at pivot.
12	2	Tape cover latch.	1 or 2 drops at pivot and working points.
13	1	Governor adjustment screw (TT-123A/FG).	Apply sparingly to entire thread.
13	2	Governor adjustment gear (TT-123A/FG).	Apply sparingly to gear teeth.
13	3	Governor worm (TT-123A/FG).	1 or 2 drops in governor hub opening.
13	4	Governor adjustment lever (TT-123A/FG).	1 drop at each end.

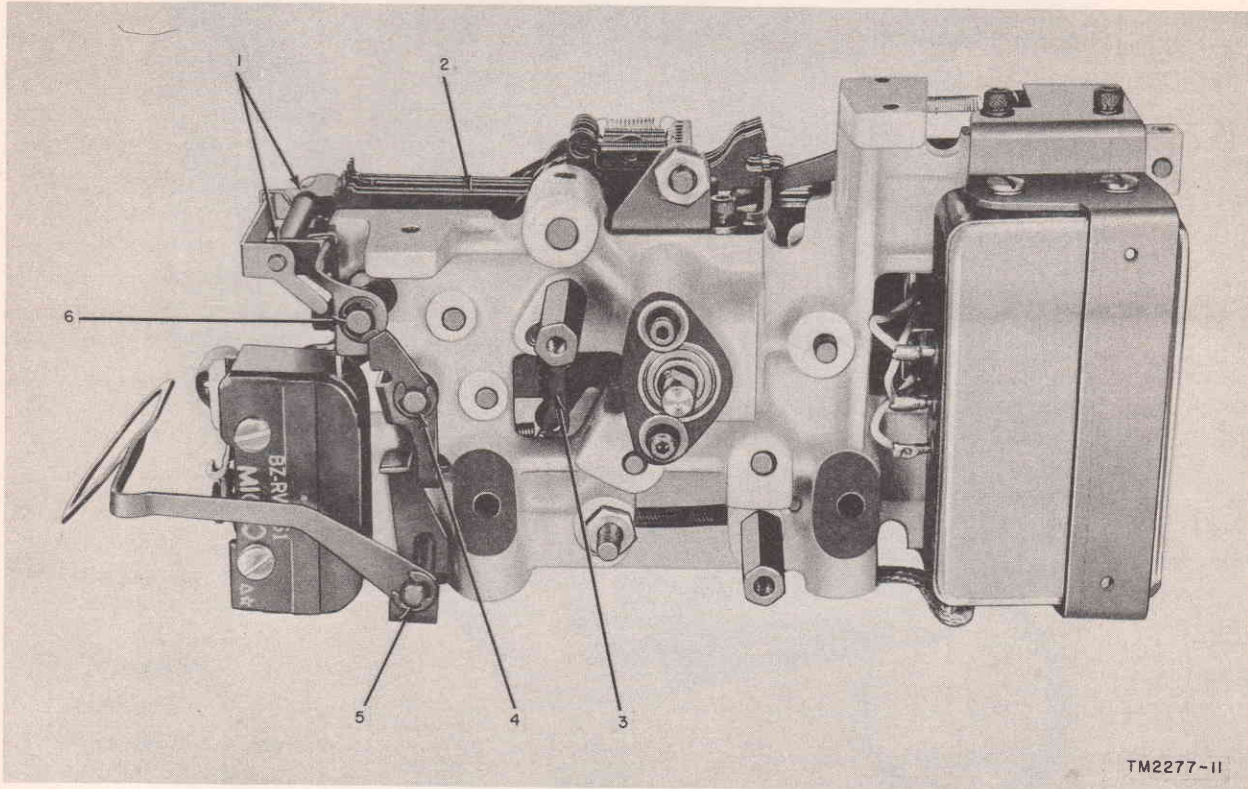

TM2277-II

- 1 Tape-out lever
- 2 Tape feed claw
- 3 Stop-start lever detent
- 4 Lower switch bail lever
- 5 Tight-tape lever
- 6 Upper switch bail lever

Figure 11. Left side of distributor-transmitter, showing lubrication points.

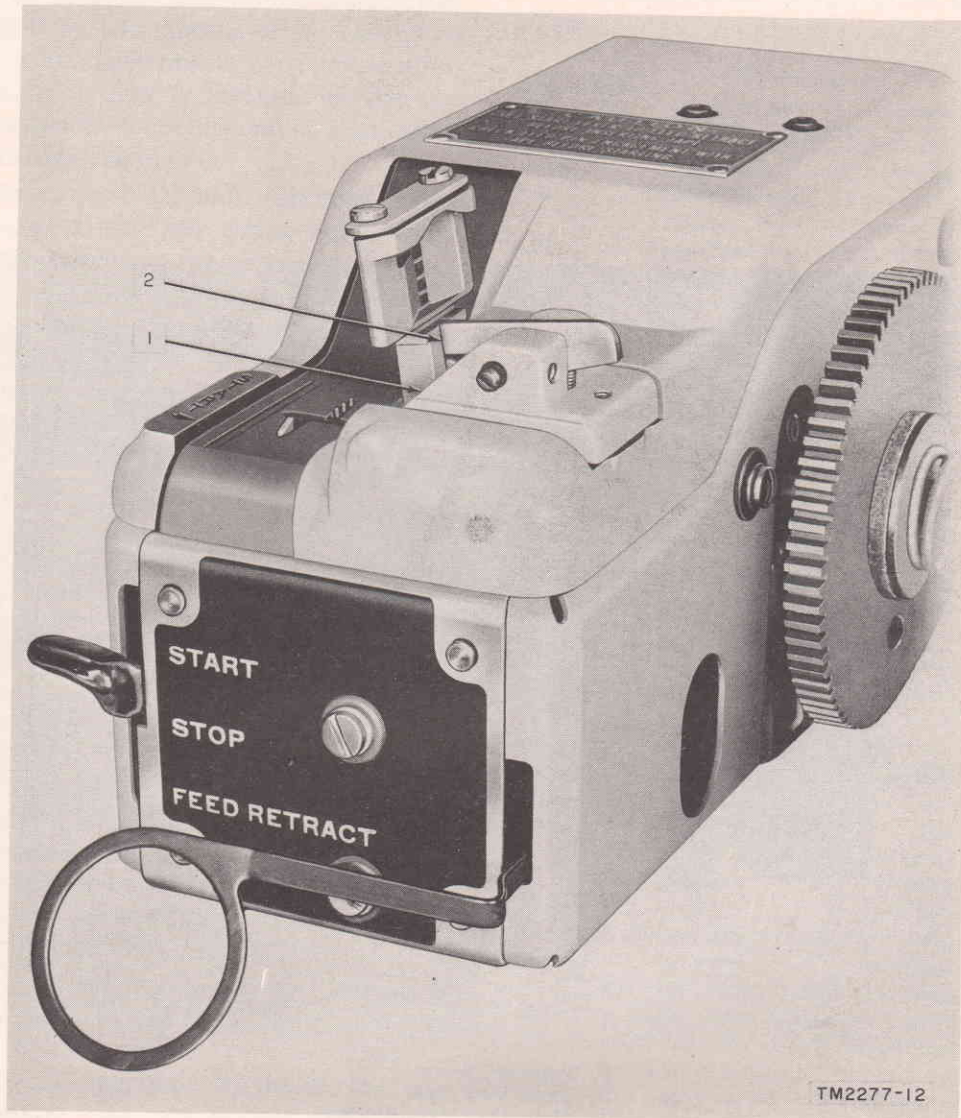

- 1 Tape cover hinge
- 2 Tape cover latch

Figure 12. Tape cover lubrication points.

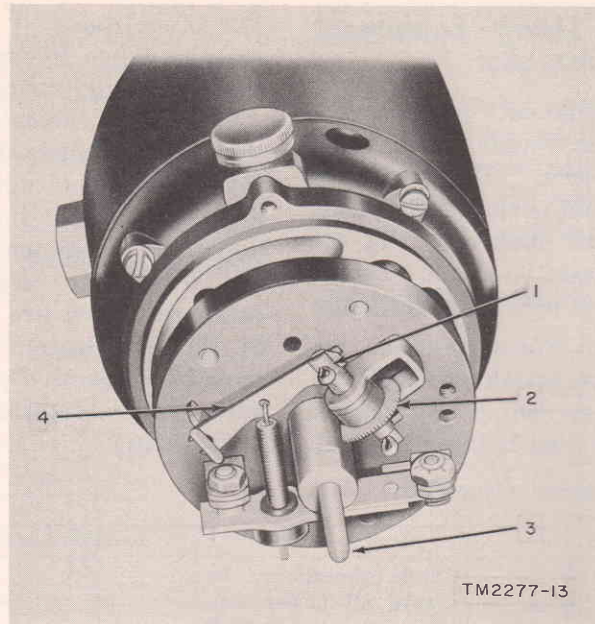

- 1 Governor adjustment screw
- 2 Governor adjustment gear
- 3 Governor worm
- 4 Governor adjustment lever

Figure 13. Motor governor, showing lubrication points (TT-123A/FG).

Section IV. TROUBLESHOOTING AT ORGANIZATIONAL MAINTENANCE LEVEL

Note. This section contains instructions for troubleshooting at organizational level. Troubleshooting at field maintenance level is described in chapter 5.

35. General

Troubleshooting at the organizational maintenance level requires that the trouble be sectionalized by tracing it to a faulty component as quickly as possible. It then must be determined whether the faulty component can be repaired at the organizational maintenance level or must be sent to a field repair shop. The repair work that can be performed at the organizational level is limited in scope by the tools, test equipment, and replaceable parts available.

36. Visual Inspection

Failure of equipment to operate properly usually is caused by one or more of the following visible faults:

- a. Improperly connected power or signal cord.
- b. Burned-out fuse (fig. 4).
- c. Loose signal line or clutch magnet connections on terminal board TB1 (10, fig. 10).
- d. Visibly worn or damaged mechanical part.

37. Sectionalizing Trouble

When the cause of trouble cannot be found by simple visual inspection (par. 36), follow the procedure outlined in the equipment performance checklist (par. 38). It is assumed in this list that the distributor-transmitter is connected to a signal line, and that good fuses are inserted properly in the fuse holders. Perform the steps in the order in which they are listed. If the trouble cannot be found by means of the equipment performance checklist; field maintenance is required.

38. Troubleshooting, Using Equipment Performance Checklist

a. *General.* The equipment performance checklist will help to locate trouble in the equipment at organizational level. The list gives the item to be checked, the normal indications and tolerances for correct operation, and the corrective measures that can be taken. *To use this list, follow the items in numerical sequence.*

b. *Action or Condition.* For some items, the information given in the action or condition column consists of various switch and control settings under which the item is to be checked.

e. Equipment Performance Checklist.

	Item No.	Item	Action or condition	Normal indications	Corrective measures
P R E P A R A T O R Y	1	Ground.	Check connections. Be sure all power connections are in OFF position while checking.	None.	Establish good connection (par. 12).
	2	Power.	Power cord plugged in.	None.	None.
	3	POWER switch.	In OFF position.	None.	None.
	4	Line connections.	Signal cord plugged into line.	None.	Connect as required (par. 17).
S T A R T	5	POWER switch.	Operate to ON.	Motor starts.	Check fuses; check power connection (par. 12).
	6	Motor speed (TT-123A/FG).	Adjust (par. 14b).		
E Q U I P M E N T P E R F O R M A N C E	7	Transmitting mechanism.	Test tape in position. Stop-start lever at START.	Should transmit from tape.	Adjust tight-tape and tape-out linkage (pars. 49 and 56).
	8	Tight-tape lever.	Raise lever.	Transmission should stop.	Adjust tight-tape and tape-out linkage (pars. 49 and 56).
	9	Tape-out lever.	End of message tape passes over tape-out lever.	Transmission should stop.	Adjust tape-out lever, tape-out linkage, and switch (pars. 49 and 56).
S T O P	10	POWER switch.	Operate to OFF.	Motor should stop.	Check switch.

For other items, it represents an action that must be taken to check the indication given in the normal indications column.

c. *Normal Indications.* The normal indications listed include the visible and audible signs that should be noted when the items are checked. If the indications are not normal, apply the recommended corrective measures.

d. *Corrective Measures.* The corrective measures listed are those which can be made by the organization technician. If the recommended corrective measures do not yield results, troubleshooting at field maintenance level is necessary.

Section V. DISTRIBUTOR-TRANSMITTER ADJUSTMENT PROCEDURES

39. General

This section contains the requirement and adjustment procedures for the distributor-transmitter. Complete the individual checks and, if required, make the necessary adjustments. Adjustments are arranged in sequence

for a complete readjustment of the distributor-transmitter. Adjustments not otherwise specified apply to both the TT-122A/FG and the TT-123A/FG; those applicable only to the TT-122A/FG or TT-123A/FG are so identified. When making individual adjustments,

check all related adjustments. When it is necessary to remove parts or subassemblies to make an adjustment, refer to specific removal and replacement instructions (pars. 89-105).

40. Drive Gearset Adjustment (fig. 14)

a. *Requirement.* There should be minimum backlash without binding between the worm gear and motor-driven gear.

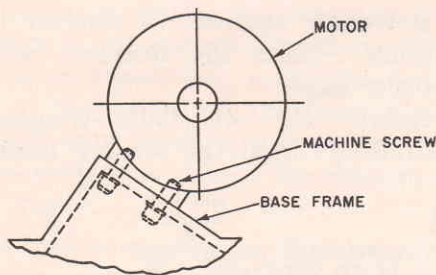
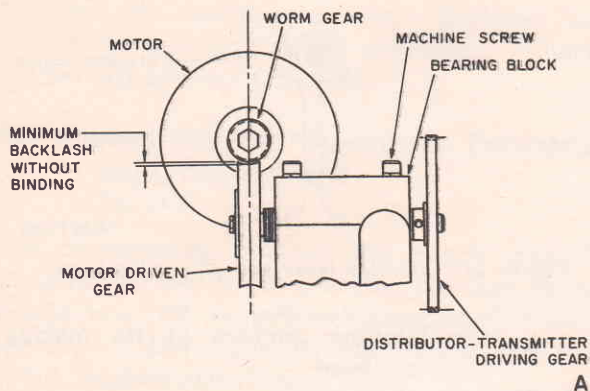

B
TM2277-14

Figure 14. Drive gearset adjustment.

b. *Adjustment.* Loosen the four machine screws on the bearing block (A, fig. 14) and the four machine screws that hold the motor to the base frame (B, fig. 14). Slide the motor up or down and the motor-driven gear back and forth until requirement is met. Make sure the center lines of the worm gear and motor-driven gear are in line. Tighten the four bearing block and four motor mounting machine screws and recheck the requirement.

41. Distributor-Transmitter Driving Gear and Driven Gear Alinement (fig. 15)

a. *Requirement.* The faces of the distribu-

tor-transmitter driving gear should be parallel and at least $\frac{1}{64}$ inch inward from the faces of the distributor-transmitter driven gear.

b. *Adjustment.* Loosen the two setscrews in the hub of the distributor-transmitter driving gear. Move the distributor-transmitter driving gear until the requirement is met. Tighten the setscrews and recheck the requirement.

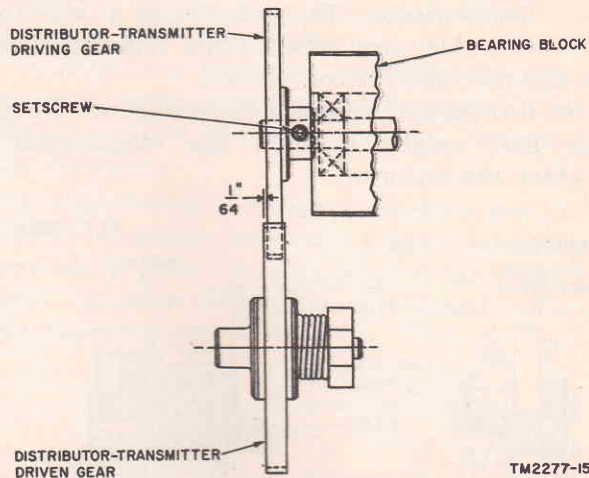

TM2277-15

Figure 15. Distributor-transmitter driving gear and driven gear alinement.

42. Distributor-Transmitter Driving Gear and Driven Gear Backlash Adjustment (fig. 16)

a. *Requirement.* There should be minimum backlash without binding between the distributor-transmitter driving gear and driven gear.

b. *Adjustment.* Loosen the two machine screws that hold the tape transmitter to the

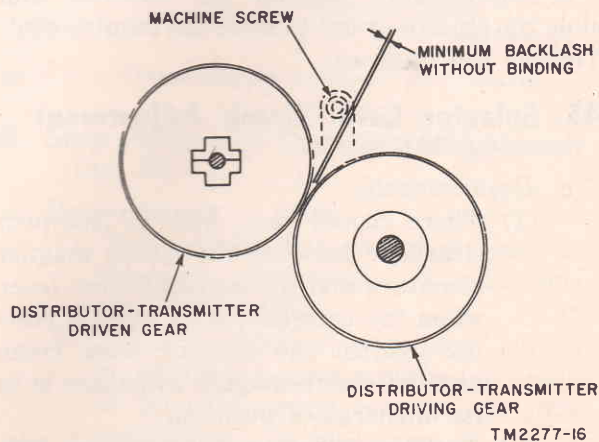

TM2277-16

Figure 16. Distributor-transmitter driving gear and driven gear backlash adjustment.

base frame (figs. 49 and 60). Move the entire tape transmitter toward the front or rear until the requirement is met. Tighten the two machine screws and recheck the requirement.

43. Transmitter Contact Bail End Play Adjustment (fig. 17)

a. *Requirement.* There should be a .002- to .005-inch clearance between the retainer ring on the post and the contact bail.

b. *Adjustment.* Loosen the setscrew. Move the post axially to meet the requirement; tighten the setscrew.

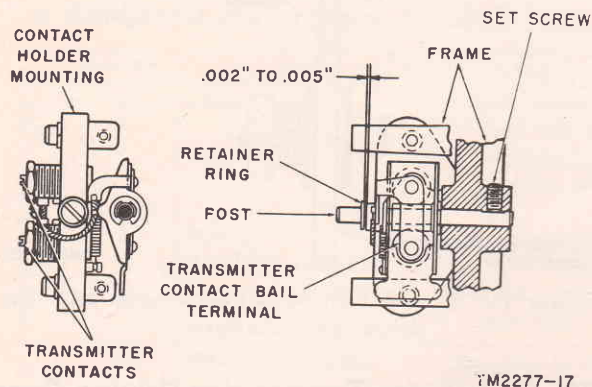

Figure 17. Transmitter contact bail end play adjustment.

44. Selector Lever End Play Adjustment (fig. 18)

a. *Requirement.* There should be a .002- to .005-inch clearance between the spacer and the first selector lever.

b. *Adjustment.* Loosen the setscrew and slide the stud in or out to meet the requirement. Tighten the setscrew.

45. Selector Lever Comb Adjustment (fig. 19)

a. *Requirements.*

- (1) There should be a .010- to .025-inch clearance between the clutch magnet armature and the camshaft stop lever when the camshaft stop lever is resting against the selector lever comb and the clutch magnet armature is in its unenergized position.
- (2) There should be a minimum of .005-inch clearance between the latching surface of each code sensing lever and

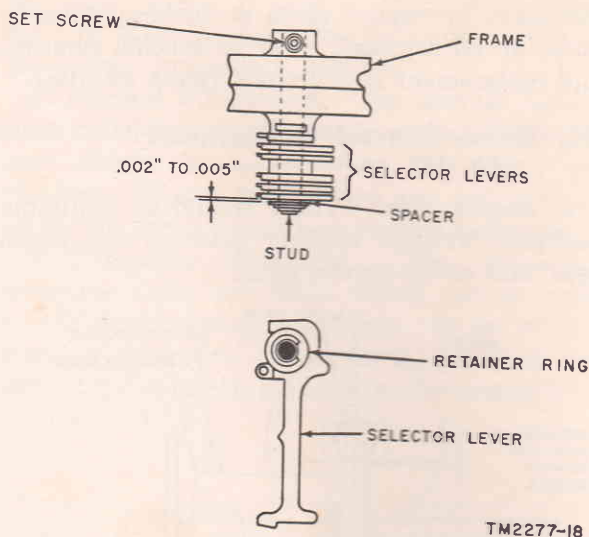

Figure 18. Selector lever end play adjustment.

the latching surface of its mating selector lever.

b. *Methods of Checking.*

- (1) Rotate the distributor-transmitter camshaft until the camshaft stop lever is resting against the selector lever comb. Check the clearance with a feeler gage.
- (2) Rotate the distributor-transmitter camshaft until the sensing lever re-

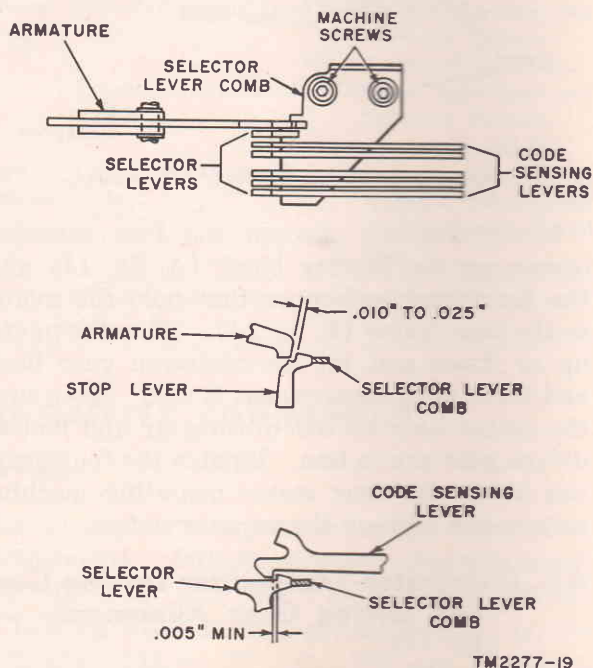

Figure 19. Selector lever comb adjustment.

storing bail is on the low part of the restoring cam and the latching ends of the code sensing levers are in engagement with their mating selector levers. Check the clearance at each of the five selector levers.

c. *Adjustment.* Loosen the two comb mounting machine screws and position the selector lever comb until the requirements are met. Tighten the machine screws. Recheck the clearances and readjust if necessary. Check related adjustment (par. 48).

46. Clutch Magnet Armature Eccentric Stud Adjustment (fig. 20)

a. *Requirement.* When the clutch magnet armature is held in its operated position, there should be a .003- to .006-inch clearance between the top of the camshaft stop lever and the clutch magnet armature.

b. *Method of Checking.* With the top cover removed (par. 94a(7)) from the distributor-transmitter, manually hold the clutch magnet armature to the operated position. Rotate the distributor-transmitter camshaft toward the front of the unit until the front edge of the camshaft stop lever is just under the clutch magnet armature. Check the clearance with a feeler gage.

c. *Adjustment.* Loosen the setscrew in the frame above the eccentric stud and rotate the eccentric stud until the requirement is met. Tighten the setscrew. Check related adjustment (par. 47).

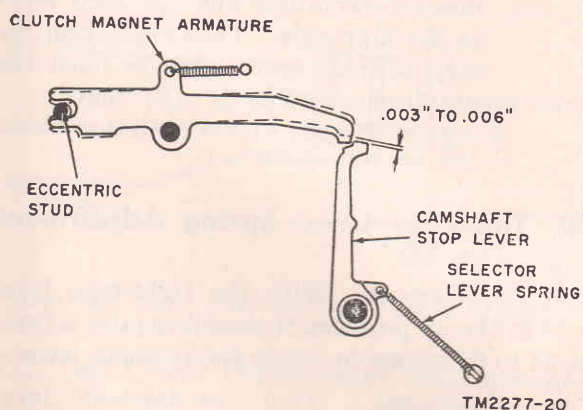

Figure 20. Clutch magnet armature eccentric stud adjustment.

47. Clutch Magnet Laminated Core Adjustment (fig. 21)

a. *Requirement.* When the clutch magnet armature is in its operated position, there should be .004-inch clearance between the clutch magnet laminated core and the clutch magnet armature. Use a piece of blank message tape as a feeler gage.

b. *Method of Checking.* Energize the clutch magnet; make sure the clutch magnet armature is against the eccentric stud, and check the clearance.

c. *Adjustment.* Loosen the two machine screws mounting the clutch magnet laminated core and position the core to meet the requirement. Tighten the machine screws and recheck the clearance.

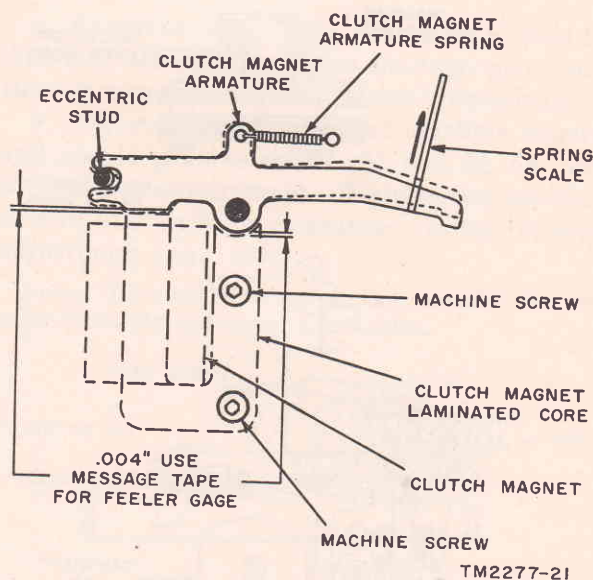

Figure 21. Clutch magnet laminated core adjustment.

48. Stop Pulse and Contacts Adjustment (fig. 22)

a. *Requirements.*

- (1) There should be a minimum break in the send circuit between successive marking impulses.
- (2) The stop selector lever latch should be adjusted to give a minimum break in the send circuit between the fifth intelligence impulse and the stop pulse. There should be a .005-inch minimum clearance between the stop selector lever and the stop selector

lever latch when the stop selector lever is on the low point of its cam

b. Method of Checking.

- (1) Arrange Multimeter ME-77/U or equivalent to read on its lowest ohmic scale and connect the meter leads in series with the signal line plug. Place a piece of message tape, perforated with the *letters* code group, in the tape transmitter. Move the stop-start lever to START and hold the clutch magnet armature in its energized position. Turn the motor by hand and observe the meter; it should indicate a slight, but minimum, break between one pair of successive marking impulses.

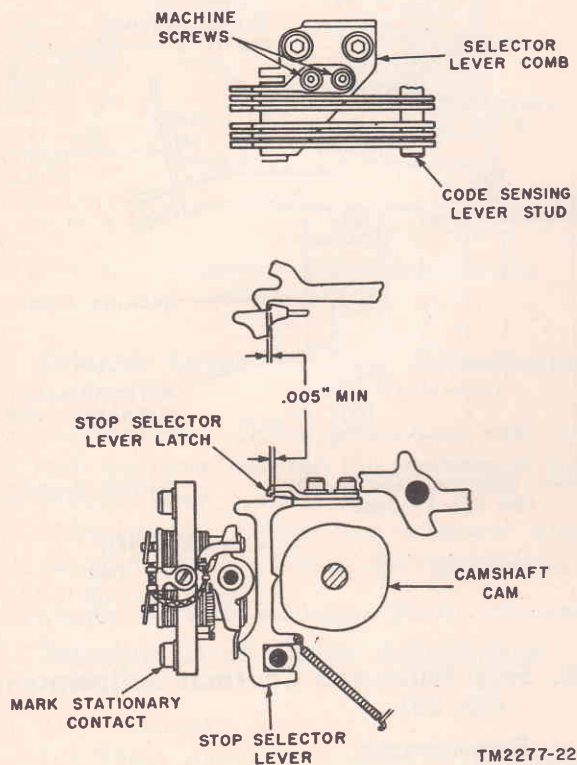

Figure 22. Stop pulse and contacts adjustment.

- (2) With the multimeter arranged as indicated in (1) above, place a piece of message tape, perforated with the T code group, in the tape transmitter. Move the stop-start lever to START and hold the clutch magnet armature in its energized position. Turn the

motor by hand and observe the meter. There should be a slight, but minimum, break indicated between the fifth intelligence impulse and the stop pulse. With the stop selector lever on the low point of its cam, check the clearance between the stop selector lever and the stop selector lever latch with a feeler gage.

c. Adjustment.

- (1) Turn the motor by hand and slowly screw the mark stationary contact down until all breaks are eliminated between successive marking impulses. Then, slowly screw the mark stationary contact upward until a slight, but minimum, break is obtained between one pair of successive marking impulses.
- (2) Loosen the machine screws that hold the stop selector lever latch. Move the stop selector lever latch to the right or left until a slight, but minimum, break is obtained between the fifth intelligence impulse and the stop pulse. Move the stop selector lever latch to the right to decrease the break and to the left to increase the break. With the stop selector lever against the low part of its cam, check the clearance between the stop selector lever and the stop selector lever latch. If the clearance is less than .005 inch, repeat the adjustment given in paragraph 45, setting the .010- to .025-inch clearance between the clutch magnet armature and the stop lever to the high side. Then reposition the stop selector lever latch to meet the requirement given in a(2) above.

Note. Use the ST-383*/GG, if available, for this adjustment.

49. Tape-Out Lever Spring Adjustment (fig. 23)

a. Requirement. With the tight-tape lever held in the up position, it should require a force of 84 to 98 grams to rotate the tape-out lever.

b. Adjustment. Wind the tape-out lever spring about the tape-out lever pivot shaft to meet the requirement.

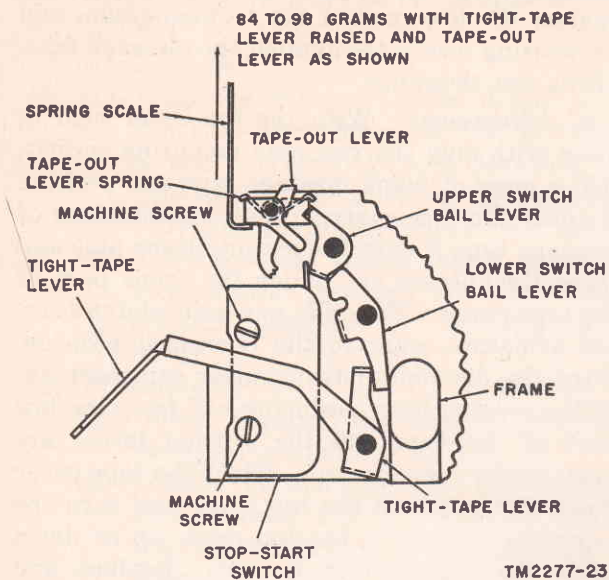

Figure 23. Tape-out lever spring adjustment.

50. Tape Cover and Tape Guide Adjustment (fig. 24)

a. Requirement. There should be a .003-inch maximum clearance between the tape guide and the tape cover.

b. Adjustment. Back the set screws away from the adjustment screws. Adjust the adjustment screws to meet the requirement when the tape guide is held against the heads of the adjustment screws. Tighten the setscrews against the adjustment screws. Check related adjustments (pars. 51, 54, and 55).

Note. To make this adjustment, remove the tape cover from the top cover.

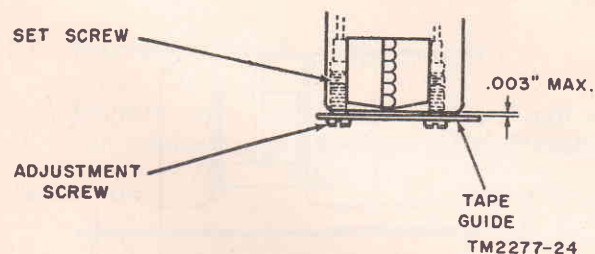

Figure 24. Tape cover and tape guide adjustment.

51. Top Cover Preliminary Adjustment (fig. 25)

a. Requirement. The tape cover should be parallel with the tape guide in the top cover.

b. Adjustment. Loosen the setscrew and turn the eccentric screw clockwise or counterclockwise to meet the requirement. Check related adjustment (par. 55).

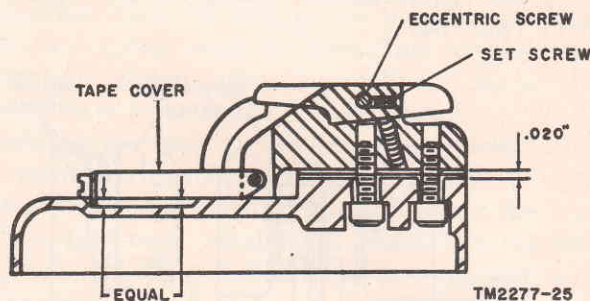

Figure 25. Top cover preliminary adjustment.

52. Tape Cover Clearance Adjustment (fig. 26)

a. Requirement. There should be a .012- to .015-inch clearance between the tape cover and the top cover of the distributor-transmitter.

b. Adjustment. Loosen the machine screws and add or remove shims (31 and 32, fig. 52) to meet the requirement. Tighten the machine screws and recheck clearance. Check related adjustment (par. 53).

Note. To make this adjustment, remove the top cover from the distributor-transmitter.

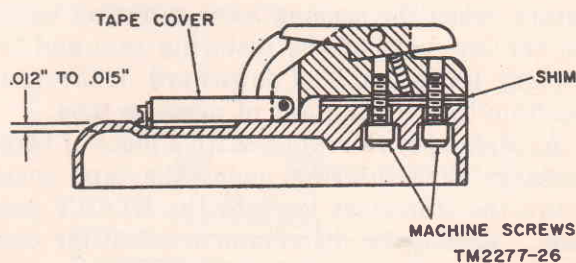

Figure 26. Tape cover clearance adjustment.

53. Tape Cover Block Adjustment (fig. 27)

a. Requirement. There should be a .002- to .005-inch clearance between the edge of the tape guide of the top cover and the message tape when the code holes of a message tape perforated with the LTRS code combination are centered with the holes in the tape cover.

b. Method of Checking. Perforate a message tape with the LTRS code combination and position the message tape .002- to 0.005-inch away from the tape guide. The holes of the tape

cover should be centered over the perforations in the message tape.

c. *Adjustment.* Loosen the two machine screws and position the tape cover block, to meet the requirement. Check related adjustment (par. 54).

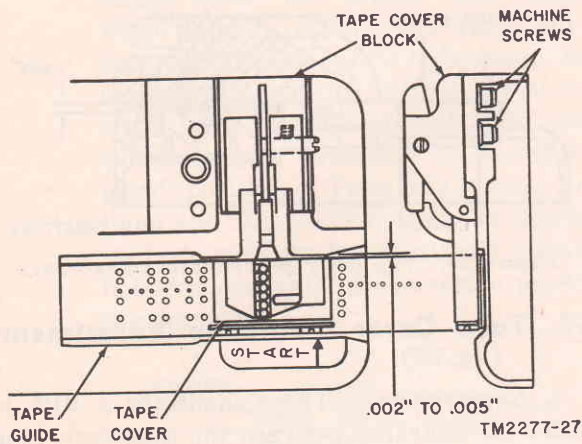

Figure 27. Tape cover block adjustment.

54. Selector Lever and Code Sensing Lever Clearance Adjustment (fig. 28)

a. *Requirement.* There should be a .015- to .025-inch clearance between the top of the selector levers and the tip of the code sensing levers, when the sensing lever restoring bail is on the low part of the restoring cam and the sensing levers are held downward in the space position by a blank piece of message tape.

b. *Method of Checking.* With a piece of blank message tape inserted under the tape cover, move the stop-start lever to the START position. Rotate the distributor-transmitter cam-

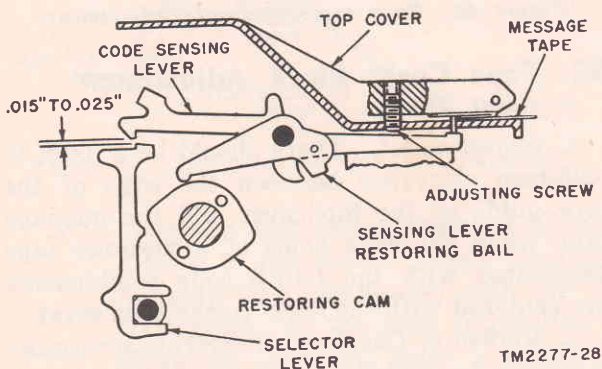

Figure 28. Selector lever and code sensing lever clearance adjustment.

shaft until the sensing lever restoring bail is against the low part of the restoring cam and the sensing levers are against the message tape. Check the clearance.

c. *Adjustment.* With the top cover held in place with only the two rear mounting screws, fold a piece of blank message tape and position it under the tape cover so that one thickness of message tape is over the sensing lever pins and three thicknesses are under the front part of the tape cover. Manually move the clutch magnet armature lever to the energized position. Turn the distributor-transmitter camshaft until the sensing lever restoring bail is on the low part of the cam and the sensing levers are against the message tape. Hold the tape cover down tight against the top cover and turn the adjusting screws in the top cover up or down until the requirement is met. Replace and tighten the front mounting screw. Recheck the clearance. Check related adjustments (pars. 55 and 56).

Note. Turn the adjusting screws clockwise to decrease the clearance, or counterclockwise to increase the clearance.

55. Top Cover Adjustment (fig. 29)

a. *Requirement.* With the tape feed claw engaging the feed holes of the message tape, the edge of the message tape should be .002- to .005-inch from the guide of the top cover.

b. *Adjustment.* Loosen the three machine screws mounting the top cover and position the top cover to meet the requirement. Tighten the mounting machine screws and recheck the requirement.

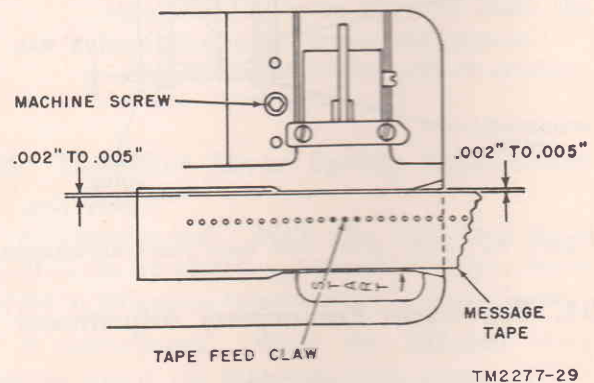

Figure 29. Top cover adjustment.

56. Upper Switch Bail Lever Adjustment (fig. 30)

a. Requirements.

- (1) With the stop-start lever detent and the stop-start lever in the position shown, there should be a clearance of .005 to .025 inch between the tape-out lever and the upper switch bail lever.
- (2) The stop-start switch should be actuated midway between the STOP and START positions of the stop-start lever.

b. Adjustments.

- (1) Obtain required clearance by bending the upper switch bail lever.
- (2) Loosen the two stop-start switch machine screws and position the stop-start switch to meet the requirement; tighten the machine screws.

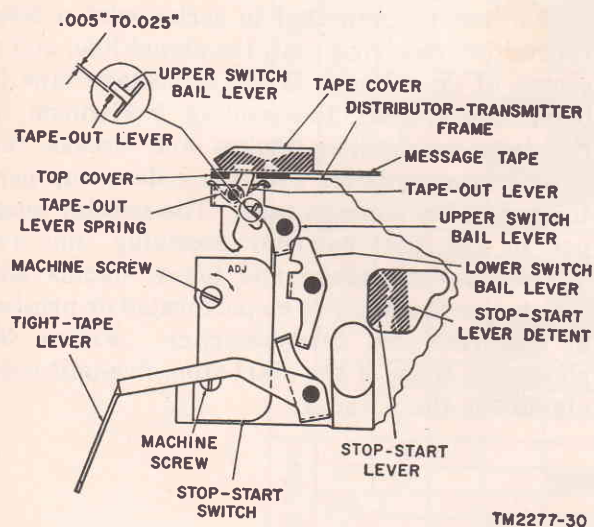

Figure 30. Upper switch bail lever adjustment.

57. Friction Clutch Adjustment (fig. 31)

a. Requirement. It should require a pull of 41 to 48 ounces to prevent the friction clutch

from turning when the motor is on and the distributor-transmitter camshaft is not operating any levers.

b. Method of Checking. Install a piece of punched message tape in the tape transmitter. Hook a spring scale on a machine screw of the friction clutch adjusting collar. Move the stop-start lever to the START position. While holding the scale rigidly, allow the distributor-transmitter camshaft to turn just slightly until it is not operating any levers. When the free spot has been established, hold the friction clutch adjusting collar from turning and read the scale.

c. Adjustment. Loosen the two machine screws in the friction clutch adjusting collar, rotate the collar forward or backward to obtain the proper spring tension on the friction clutch, and then tighten the machine screws. Check the requirement and readjust if necessary.

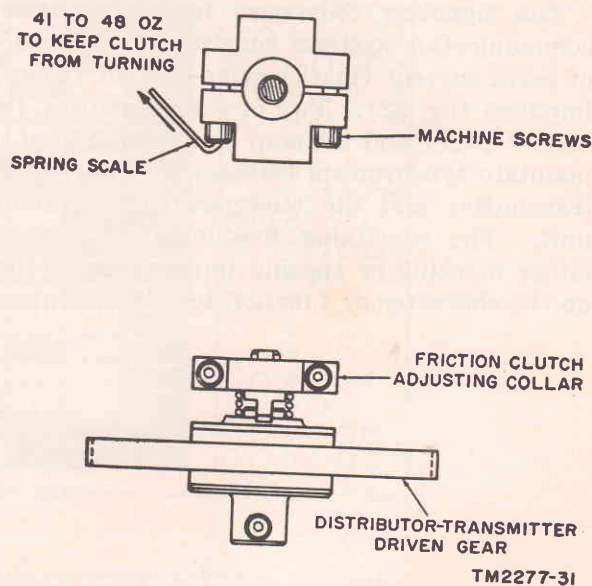

Figure 31. Friction clutch adjustment.

CHAPTER 4

THEORY

Section I. INTRODUCTION

58. General

Teletypewriter Distributor-Transmitters TT-122A/FG and TT-123A/FG are identical, except that the TT-122A/FG uses a synchronous motor and the TT-123A/FG uses a series-governed motor. The distributor-transmitters are arranged to send neutral signals at 60 or 100 wpm, depending on the drive gearset (par. 14b) installed.

59. Start-Stop Five-Unit Code

The signaling code used in teletypewriter communication systems consists of a sequence of seven-current (mark) or no-current (space) impulses (fig. 32). Two of these impulses, the start (space) and the stop (mark) are used to maintain synchronism between the distributor-transmitter and the teletypewriter receiving unit. The remaining five impulses may be either marking or spacing impulses depending on the character or function to be transmitted.

All possible variations of the five selecting impulses provide 32 different code combinations, which are assigned to individual letters and functions (fig. 32).

60. Typical Application, Block Diagram

A typical application of a distributor-transmitter is shown in figure 33. The distributor-transmitter is connected in series with a teletypewriter receiving unit, the signal line, and a source of dc voltage. When a message tape is being transmitted, the sending mechanism in the tape transmitter makes and breaks the circuit in accordance with the code group perforated in the message tape. The selector magnet in the teletypewriter receiving unit responds to these make and break signals and selects the character to be perforated or printed at the receiving teletypewriter. Figure 34 shows the form of the start-stop, five-unit code signal for the letter X.

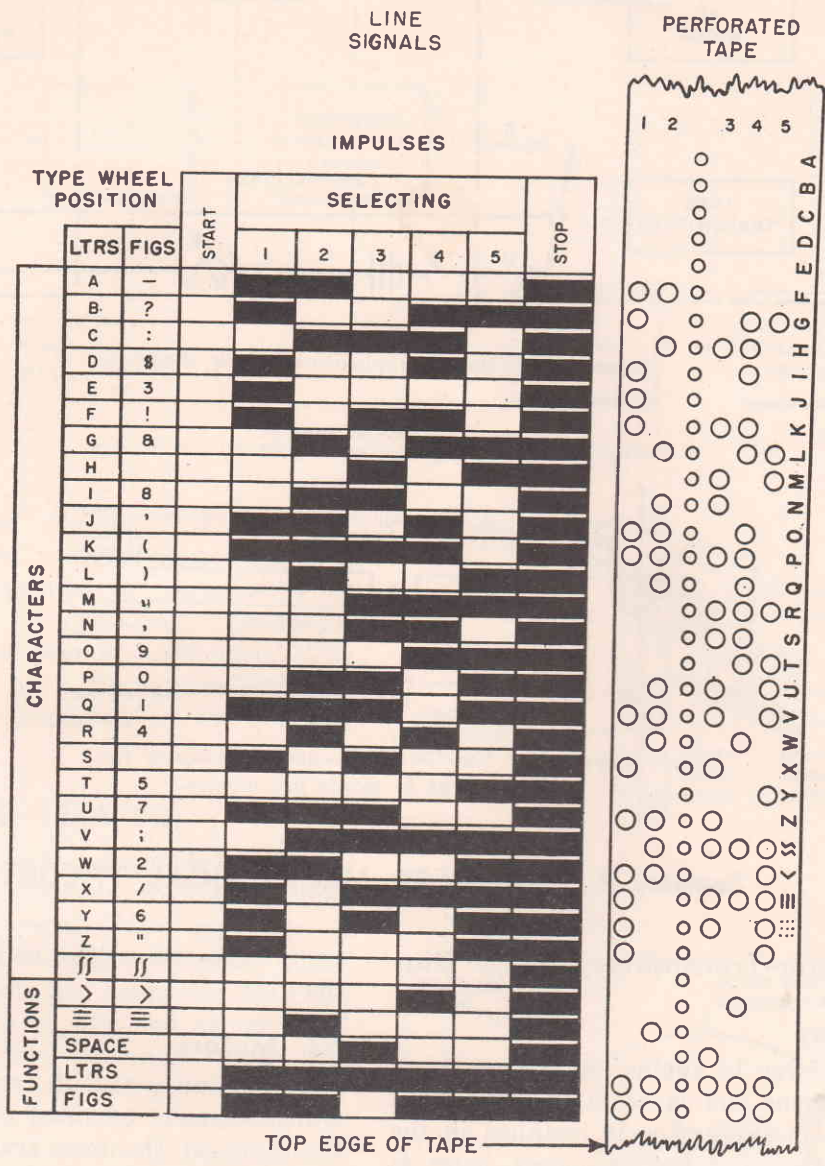

SIGNAL LENGTH IN MILLISECONDS. STANDARD SPEED 60 WORDS PER MIN

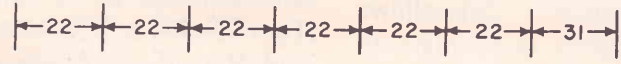

SPACING IMPULSES
 MARKING IMPULSES

TM2277-32

Figure 32. Start-stop, five-unit code chart.

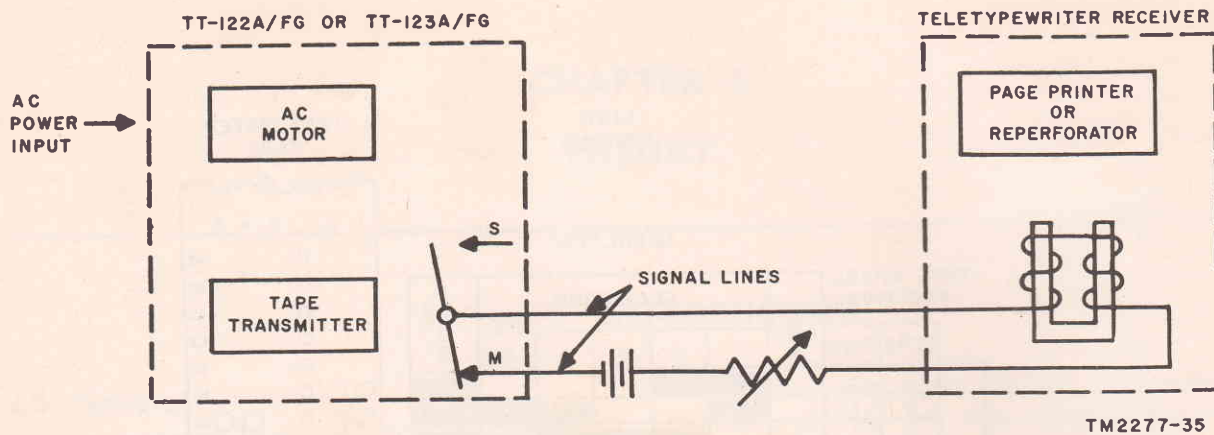

TM2277-35

Figure 33. Typical application, block diagram.

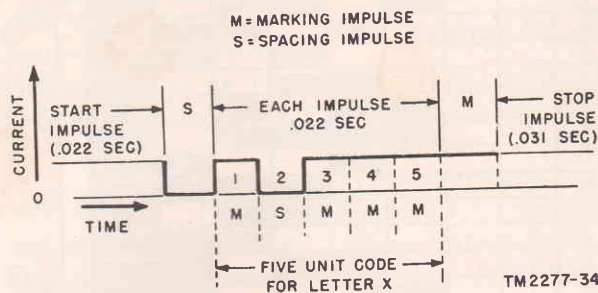

TM2277-34

Figure 34. Start-stop, five-unit code signal for letter X at 60 words per minute.

Section II. DETAILED MECHANICAL THEORY

61. Distributor-Transmitter, Block Diagram

(fig. 35)

When ac power is applied to the motor, a power shaft turns and causes a friction clutch to slip. If a message tape is installed in the tape transmitter and the stop-start lever is moved to START, the clutch magnet energizes and permits the friction clutch to drive the distributor-transmitter camshaft. This allows the levers in the tape sensing mechanism to move to a position that corresponds to the code perforated in the message tape. The mechanical position of these levers are interpreted by the code transmitting mechanism and converted to electrical start-stop, five-unit code impulses which are sent to the signal line. After each code group is transmitted, the tape feed mechanism advances the message tape and the proc-

ess is repeated as long as a message tape is in the unit.

62. Motors

The motor used with each of the distributor-transmitters is mounted on the base frame to the right of the tape transmitter unit. The motor provides the mechanical power to operate the various levers, cams, and shafts used in tape sensing and code sending operations. The TT-122A/FG uses a synchronous motor and the TT-123A/FG uses a series-governed motor.

a. *Synchronous Motor (TT-122A/FG)*. This motor requires a single-phase, 115-volt, 60-cycle ac input power source and develops 1/30 horsepower at 3,600 rpm. The motor has a squirrel cage type armature. A run winding and a start winding develop the torque required for operation.

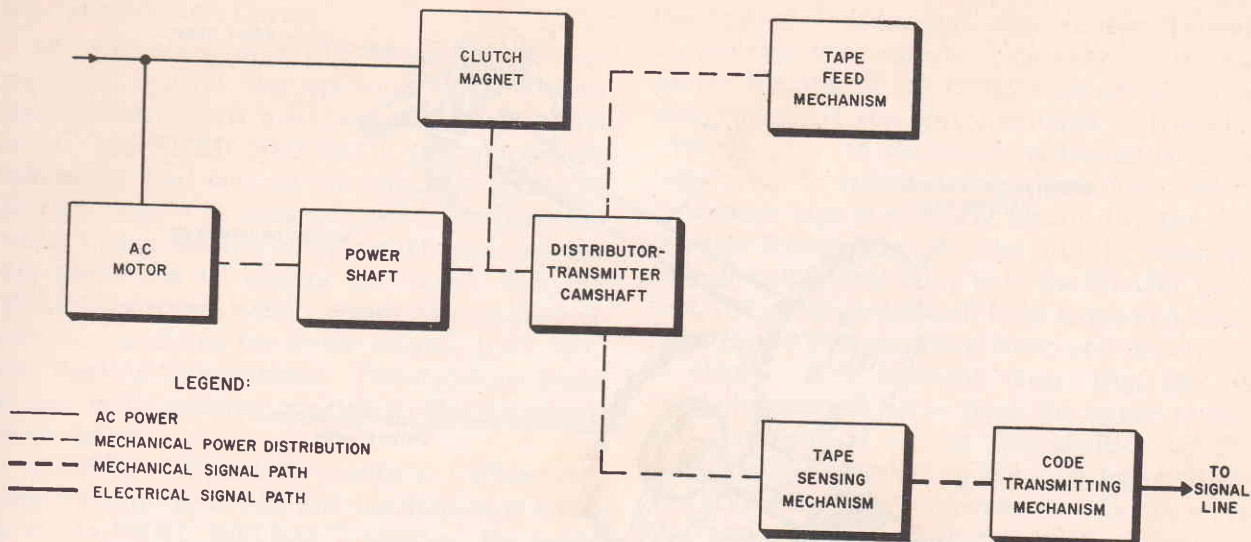
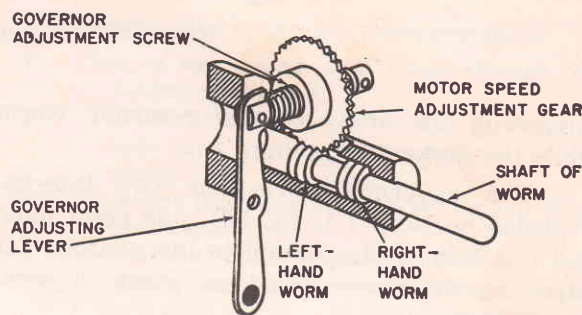

Figure 35. Distributor-transmitter, block diagram.

TM2277-33

b. *Series-Governed Motor (TT-123A/FG).*
 This motor requires a single-phase, 115-volt, 50- to 60-cycle, regulated or unregulated ac input power source for operation. The motor develops 1/23 horsepower at 3,600 rpm. The speed is controlled by a mechanical governor assembly (par. 63) mounted on the rotating motor shaft.



A

63. Governor (TT-123A/FG)

a. The motor governor assembly is adjustable to permit the motor speed to be maintained at precisely 3,600 rpm. The governor is mounted on, and rotates with, the motor shaft. The governor contacts are connected in series with the field coils (fig. 46) and armature of the motor through two sliprings (located on the back of the motor speed governor base) which are contacted by two brushes in the motor housing. The movable electrical contact of the governor (B, fig. 36) is flexible and is held against the stationary electrical contact by a coil spring until the motor speed exceeds 3,600 rpm. When this occurs, the centrifugal force acting on the movable electrical contact is greater than the tension of the spring. The movable electrical contact then moves away from the stationary electrical contact. The speed at which the contacts will open depends on the tension applied to the spring by the governor adjusting lever. The tension on the spring may be increased or decreased by ma-

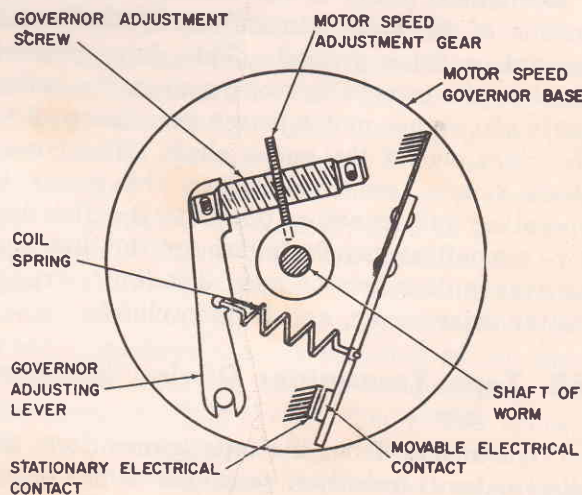

B

TM2277-36

Figure 36. Motor governor, functional view (TT-123A/FG).

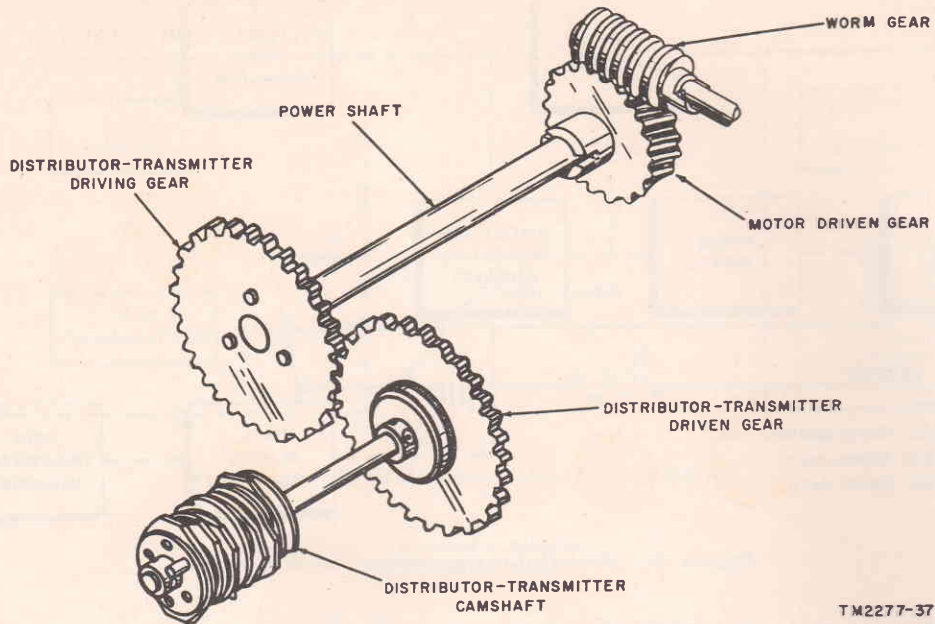

Figure 37. Mechanical power distribution.

nipulating the shaft of the governor worm while the motor is running.

b. The governor worm has two integral threaded portions (A, fig. 36), one right hand and one left hand. Complete instructions for adjusting the motor speed are given in paragraph 14a.

64. Power Distribution (fig. 37)

Mechanical power is distributed to the mechanisms of the tape transmitter by the motor through a drive gearset. This drive gearset consists of a removable worm gear on the motor shaft and a fiber motor-driven gear fastened to the right end of the power shaft. The power shaft rotates constantly when the motor is operating and transfers power to the distributor-transmitter camshaft through the distributor-transmitter driving gear, distributor-transmitter driven gear, and friction clutch.

65. Tape Transmitter Driving Mechanism

To transmit from the tape transmitter, the distributor-transmitter camshaft must rotate $\frac{1}{2}$ revolution for each code group. Power to rotate the camshaft is supplied by the motor through a friction clutch assembly. The fric-

tion clutch assembly consists of two friction plates, two clutch disks, a compression spring, and an adjusting collar (fig. 38). The friction plates are held tightly against the distributor-transmitter driven gear by the clutch disks, compression spring, and adjusting collar. When the clutch magnet is energized (par. 69), the pressure on the driven gear is sufficient to rotate the camshaft. When the camshaft is mechanically blocked (clutch magnet deenergized), the friction between the friction plates and the driven gear is overcome and the camshaft stops. The driven gear continues to rotate and maintains a steady torque on the camshaft, permitting it to resume rotation immediately when the clutch magnet is again energized.

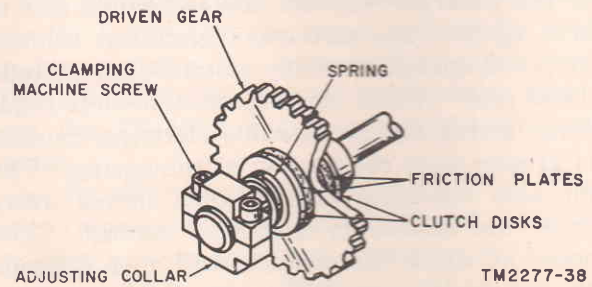

Figure 38. Distributor-transmitter camshaft friction clutch.

66. Stop-Start Lever

The stop-start lever (fig. 39) is provided to manually control the operation of the tape transmitter. There are three positions for this lever; the FEED RETRACT position, which lowers the feed pins on the tape feed claw and permits tape to be inserted; the STOP position which opens the start-stop switch and permits the feed pins to engage the tape; and the START position which closes the stop-start switch, energizing the clutch magnet (par. 69), and starting transmission. The stop-start lever is held in its selected position by the stop-start lever detent.

a. FEED RETRACT position. When the tape transmitter is idle and the stop-start lever is in the FEED RETRACT position, the parts are positioned as follows:

- (1) The tape feed claw is disengaged from the tape feed holes in the message tape (par. 72).
- (2) The lower switch bail lever is pivoted counterclockwise.
- (3) The upper switch bail lever is pivoted clockwise.
- (4) The switch operating lever is depressed (moved to the left).
- (5) The stop-start switch is open.

b. STOP position. When a message tape is inserted in the tape transmitter and the stop-start lever is moved to the STOP position, the tape feed claw moves into engagement with the feed holes in the message tape. The other parts remain in the position described in *a* above.

c. START position. When the stop-start lever is moved from STOP to START the parts move as follows:

- (1) The lower switch bail lever pivots clockwise.
- (2) The upper switch bail lever pivots counterclockwise.
- (3) The switch operating lever moves away from the switch housing.
- (4) The switch closes and energizes the clutch magnet.
- (5) Message perforated on tape is transmitted.

67. Tape-Out Lever

The tape-out lever is provided to stop transmission from the distributor-transmitter when

the end of the message tape passes through the sensing mechanism. This prevents the repeated sending of the LTRS code group which would occur if the unit continued to transmit without tape. It also stops transmission if the tape cover is raised during operation. When a message tape is properly installed in the distributor-transmitter and the unit is transmitting, the stop-start lever is in the START position, the lower switch bail lever is pivoted away from the switch operating lever, and the switch is closed. The tape-out lever (fig. 39) is pivoted clockwise away from the upper switch bail lever and is held in this position by the message tape installed in the tape transmitter. The following chart summarizes the sequence of events that occurs when the end of the message tape passes through the distributor-transmitter:

TAPE-OUT LEVER OPERATION SEQUENCE CHART

1	End of the message tape passes through the sensing mechanism.
2	Tape-out lever, no longer blocked by the message tape, pivoted counterclockwise by its spring.
3	Tape-out lever moves upper switch bail lever clockwise.
4	Lower end of the upper switch bail lever moves the switch operating lever toward stop-start switch and opens the stop-start switch.
5	Clutch magnet deenergizes and stops transmission (par. 71).

68. Tight-Tape Lever

The tight-tape lever stops transmission from the tape transmitter when the message tape becomes excessively tight, and prevents the feed holes in the message tape from being torn or damaged. To accomplish this the message tape is threaded through the hole in the tight-tape lever. This permits the lever to rise and open the stop-start switch in the clutch magnet circuit when the message tape becomes taut. When a message tape is installed in the tape transmitter and the unit is transmitting, the stop-start switch is closed. The switch operating lever is away from the switch housing, the upper switch bail lever is pivoted counterclockwise, and the lower switch bail lever is pivoted clockwise. The tight-tape lever is in its counterclockwise position, out of engagement with

the lower switch bail lever. The following chart summarizes the sequence of events when the message tape becomes taut.

TIGHT-TAPE LEVER SEQUENCE CHART	
1	Tight-tape lever in Clutch magnet is energized and tape transmitter is transmitting.
2	Message tape starts to tighten, raising the loop end of the tight-tape lever.
3	Projection on the tight-tape lever strikes the bottom of the lower switch bail lever, causing it to pivot counterclockwise.
4	Top of the lower switch bail lever strikes the upper switch bail lever, moving the upper switch bail lever clockwise against the switch operating lever.
5	Switch operating lever moves to the left and opens the normally closed stop-start switch, deenergizing the clutch magnet and stopping transmission (par. 69).

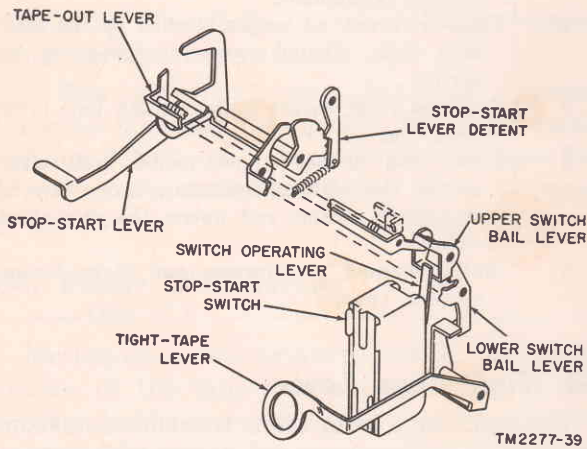

Figure 39. Control lever mechanism.

69. Control Mechanism

a. The control mechanism regulates the starting and stopping of the camshaft as directed by the tight-tape lever, start-stop lever, and tape-out lever. It consists of the clutch magnet (fig. 40), a clutch magnet armature, camshaft stop lever, and the stop lever cam, which is part of the transmitter camshaft assembly.

b. The control mechanism controls the starting and stopping of the camshaft. When the clutch magnet is deenergized (A, fig. 40) and the tape transmitter is stopped, the armature

spring holds the clutch magnet armature pivoted in its clockwise position so that it latches the blocking end of the camshaft stop lever. A projection in the middle of the camshaft stop lever engages a tooth on the stop lever cam, blocking the rotation of the camshaft. When the clutch magnet is energized (B, fig. 40), the magnetic field of force produced in the magnet attracts the rear end of the clutch magnet armature, pivoting the clutch magnet armature counterclockwise to unlatch the blocking end of the camshaft stop lever. The friction clutch then operates to turn the camshaft, moving the camshaft stop lever out of the path of the tooth on the stop lever cam. As the high point of the stop lever cam passes the projection on the camshaft stop lever, the camshaft stop lever spring pivots the camshaft stop lever back into the path of the second tooth on the stop lever cam and permits the clutch magnet armature to again engage the blocking end of the camshaft stop lever if the magnet is deenergized.

c. The sequence chart in paragraph 73 summarizes the sequence of operations for the tape

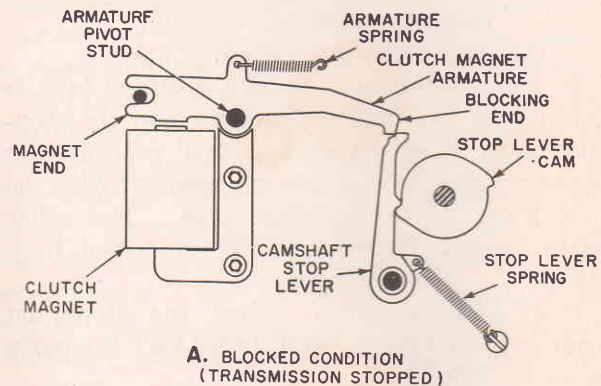

A. BLOCKED CONDITION (TRANSMISSION STOPPED)

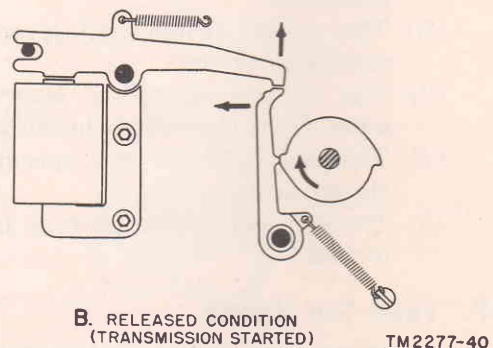

B. RELEASED CONDITION (TRANSMISSION STARTED)

Figure 40. Camshaft control mechanism.

transmitter and shows the relationship of the control mechanism to the other operations.

70. Tape Sensing Mechanism

The tape sensing mechanism translates the holes punched into a message tape into mechanical settings. It consists of five identical code sensing levers (fig. 41) and sensing lever springs, a sensing lever restoring bail, and a sensing lever restoring cam that is part of the camshaft assembly.

a. The five code sensing levers are mounted on the code sensing lever stud in such a manner that the pins at the end of the code sensing levers are aligned with the code holes that are punched into a message tape and constitute the teletypewriter code group for the letter or function to be transmitted (fig. 32). When the camshaft is in the *at rest* position, the sensing lever restoring bail (fig. 41) is held at its farthest clockwise position by the sensing lever restoring cam, holding the pin end of the code sensing levers down and out of engagement with the message tape.

b. When the camshaft starts to rotate (par. 69), the sensing lever restoring bail cam follower moves to the low portion of the sensing lever restoring cam, pivoting the sensing lever restoring bail counterclockwise and releasing the code sensing levers. The code sensing lever springs pivot the code sensing levers counterclockwise, raising the pin end upward into engagement with the message tape.

c. If the message tape has no hole above the pin of a code sensing lever, the counterclockwise movement of the code sensing lever is blocked and the code sensing lever is positioned for a spacing impulse. If the message tape has a hole above the pin of the code sensing

lever, the counterclockwise movement of the code sensing lever continues, positioning the code sensing lever for a marking impulse. In this manner, the five code sensing levers are positioned in the marking or spacing position for the code group to be transmitted.

d. The sequence chart in paragraph 73 summarizes the sequence of operations for the tape transmitter and shows the relation of the tape sensing mechanism to the other operations.

71. Code Transmitting Mechanism

The code transmitting mechanism converts the mechanical settings of the sensing mechanism into electrical impulses which can be transmitted to the signal line. It consists of five selector levers (fig. 42), a camshaft, a transmitter contact bail, and transmitter stationary contacts. Start and stop impulses are transmitted through the interoperation of the permanently latched stop-start selector lever (fig. 43) and its associated stop-start cam.

a. If a hole is present in the message tape, the code sensing lever associated with the code impulse is moved to the marking position (par. 70). In this position, the latching end of the code sensing lever (A, fig. 42) engages the notched end of its associated selector lever, latching the upper end of the selector lever in place. When the lobe of the associated cam moves against the center projection of the selector lever, the bottom of the selector lever is forced to move toward the transmitter contact bail, pivoting the transmitter contact bail clockwise and causing the contact on the transmitter contact bail to touch the stationary contact to send a current impulse.

b. If no hole is present in the message tape, the movement of the code sensing lever is blocked (par. 70), and the code sensing lever is prevented from latching the selector lever (B, fig. 42). As the lobe of the associated cam rotates against the center projection of the selector lever, the top of the selector lever is free to move and the selector lever pivots counterclockwise. This permits the transmitter contact bail spring to open the transmitter contacts, causing a no-current or spacing impulse.

c. The start-stop impulses are transmitted when the permanently latched stop-start selector lever is moved by the stop-start cam on the

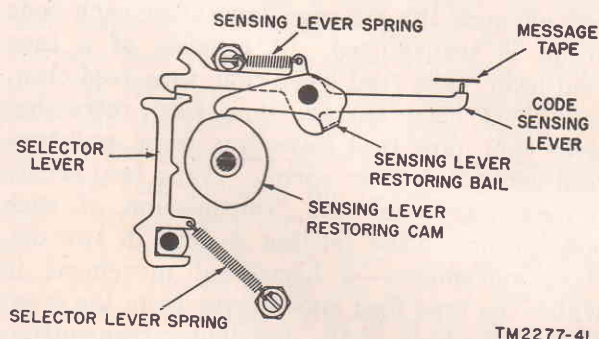

Figure 41. Tape sensing mechanism.

camshaft. When the camshaft is stopped, the lobe of the stop-start cam is pressed against the center projection of the stop-start lever (A, fig. 43), forcing the lower end of the associated selector lever against the transmitter contact bail to hold the mark transmitter contacts closed. When the camshaft starts to rotate, the high portion of the stop-start cam moves away from the center projection of the stop-start selector lever and the stop-start selector lever (B, fig. 43) is pivoted counterclockwise by the selector lever spring, permitting the transmitter contact bail spring to pivot the transmitter contact bail and open the mark transmitter contacts. This causes a no-current, start impulse to be transmitted. As the camshaft nears the end of its half revolution, the cam lobe again moves against the center projection of the stop-start selector lever to close the transmitter contacts, sending a marking, stop impulse.

d. The cams on the camshaft are arranged to operate each selector lever in turn, causing the impulse associated with that selector lever to be sent at precisely the correct instant, and to give the start and code impulses a duration

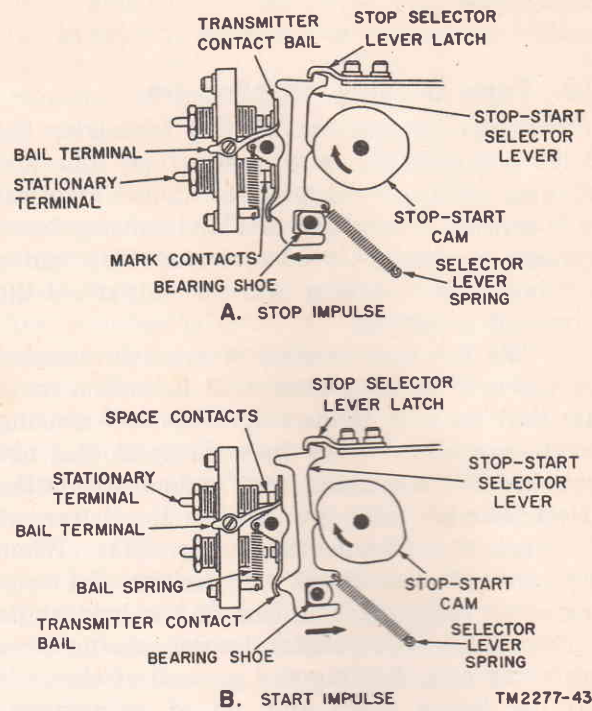

Figure 43. Transmission of start and stop impulses.

of 22 milliseconds and the stop impulse a duration of 31 milliseconds at 60 words per minute speed.

e. The sequence chart in paragraph 73 summarizes the sequence of operations for the tape transmitter and shows the relationship of the code transmitting mechanism to the other operations.

72. Tape Feed Mechanism (fig. 44)

The tape feed mechanism feeds the message tape through the tape transmitter and positions the message tape to permit the sensing mechanism to sense the perforated code group and advance the message tape after each code group is transmitted. It consists of a tape feed lever, tape feed lever cam, tape feed claw, tape feed claw spring, tape feed retracting lever cam, tape feed retracting lever, and tape feed retracting lever spring. Tape feed occurs immediately after the transmission of each code group. Tape feeding is done in two distinct movements—a horizontal movement in which the tape feed claw moves from the front toward the back of the distributor-transmitter, and a vertical movement in which the tape feed

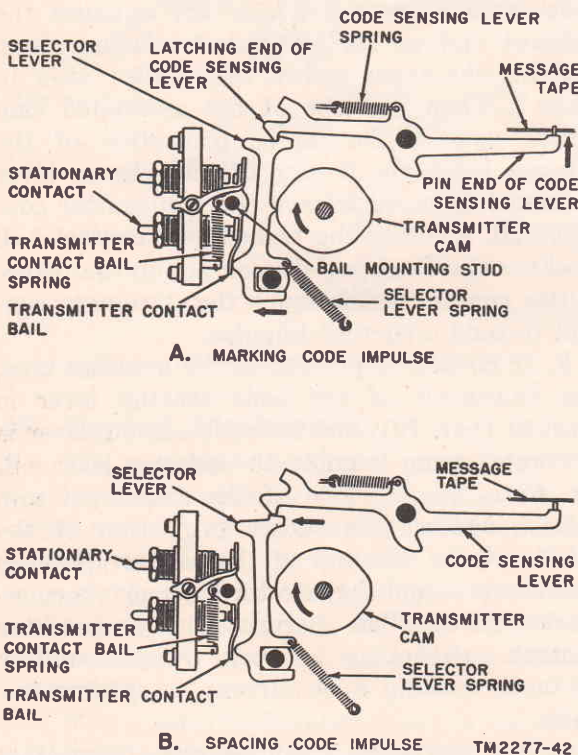

Figure 42. Transmission of marking and spacing code impulse.

claw raises and lowers to engage and disengage the feed holes in the message tape.

a. When the camshaft is in the at rest position, the tape feed lever is held in the low part of the feed lever cam by the tape feed lever spring (A, fig. 44). In this position, it is pivoted counterclockwise, and the top of the tape feed lever that engages the tape feed claw holds the tape feed claw to the left. This is the position of the tape feed claw immediately after feeding the message tape in the tape transmitter. As the camshaft starts to rotate, the tape feed lever is cammed clockwise by the feed lever cam. The clockwise movement of the tape feed lever permits the tape feed claw to pull the tape feed claw to the right where it engages the feed holes in the message tape (b below). As the high point of the feed lever cam passes the projection on the tape feed lever, the tape feed lever spring snaps the tape feed lever clockwise against the low portion of the feed lever cam and causes the top end of the tape feed lever to snap to the left, positioning the message tape for the next code group.

b. In addition to the horizontal movement (a above), the tape feed claw is also moved vertically by the tape feed retracting lever (B, fig. 44), and the tape feed retracting lever cam. A pin through the right arm of the tape feed retracting lever horizontally engages the notch in the tape feed claw. This pin causes the tape feed claw to follow the movements of the right end of the tape feed retracting lever. When the tape transmitter is at rest, the tape feed retracting lever cam follower is on the low part of the tape feed retracting cam and the right end is raised by action of the tape feed retracting lever spring, holding the tape feed claw in its upper position. At the beginning of the transmission of a code group, the tape feed retracting lever cam rotates, and cams the tape feed retracting lever clockwise, dropping the right end of the tape feed retracting lever and the tape feed claw. This lowers the pins of the tape feed claw out of engagement with the feed holes in the message tape. Before the tape feed retracting lever cam completes $\frac{1}{2}$ revolution, the tape feed retracting lever again moves to the low part of the cam, and the tape feed retracting lever spring raises the right end of the tape feed retracting lever and the tape feed claw. The combined action of

the tape feed retracting lever cam and the tape feed retracting lever moves the tape feed claw vertically, upward to engage the feed holes in the message tape and downward to disengage the feed holes after feeding.

c. The actual motion of the tape feed claw under the control of the tape feed lever, the tape feed retracting lever, and their respective cams is rectangular. The tape feed retracting lever causes the tape feed claw to engage the

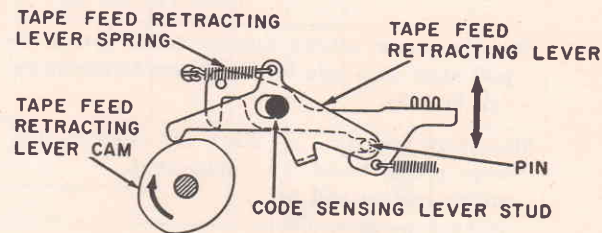
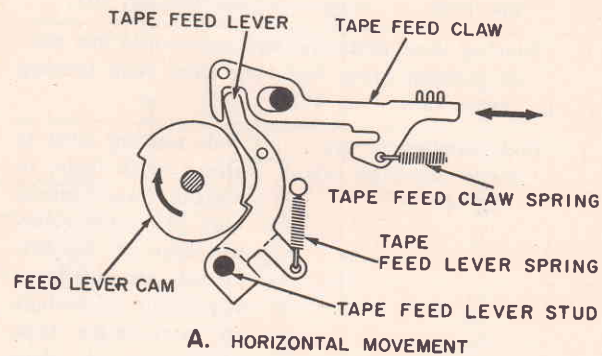

B. VERTICAL MOVEMENT TM2277-44

Figure 44. Tape feed mechanism.

message tape before feeding, and disengages the message tape after feeding. The tape feed lever causes the tape feed claw to move the tape the distance of one space and then move back to prepare to reengage the message tape for the next feeding cycle.

73. Summary of Tape Transmitter Operations

The following sequence chart summarizes the sequence of operations for the tape transmitter and shows the relationship of the tape feed cycle to the other operations. It assumes that a message tape is properly installed in the tape transmitter.

TAPE TRANSMITTER OPERATION SEQUENCE CHART	
1	Stop-start lever moved to the START position.
2	Clutch magnet energized, magnetizing the laminated core (B, fig. 40).
3	Clutch magnet armature pivoted counterclockwise by the clutch magnet, releasing camshaft stop lever (B, fig. 40).
4	Camshaft stop lever pivots counterclockwise, freeing stop lever cam (B, fig. 40).
5	Friction clutch operates. Camshaft starts rotating (B, fig. 40).
6	Sensing lever restoring bail moves into low part of sensing lever restoring cam, code sensing levers raise (fig. 41).
7	Code sensing levers strike message tape (fig. 41). If code sensing lever is alined with hole in message tape (marking), it latches selector lever (A, fig. 42). If code sensing lever is alined with no hole in message tape (spacing), it does not latch selector lever (B, fig. 42).
8	Stop-start cam allows selector lever spring to pull start-stop selector lever counterclockwise (B, fig. 43).
9	Stop-start selector lever pivots transmitter contact bail to spacing position (B, fig. 43). Start (no current) impulse sent.

TAPE TRANSMITTER OPERATION SEQUENCE CHART	
10	Camshaft causes No. 1 selector lever to pivot at top, rotating bottom, if latched (marking) (A, fig. 42) or pivot at bottom, rotating top, if not latched (spacing) (B, fig. 42). Transmitter contact bail moved to marking or spacing position sending No. 1 marking or spacing impulse (fig. 42).
11	Tape feed claw moves down out of engagement with tape feed holes (B, fig. 44).
12	Second, third, and fourth code impulses sent (fig. 42). Tape feed claw moves forward (A, fig. 44).
13	Fifth code impulse sent (fig. 42). Feed claw rises to engage with holes (B, fig. 44).
14	Stop impulse sent (A, fig. 43). Code sensing levers lowered by cam action out of way of message tape (fig. 41).
15	Tape feed lever moves to low part of cam, allowing tape feed lever spring to pull tape feed lever to the rear, moving the message tape one space (A, fig. 44).
16	Tape transmitter ready to transmit another code group.

Section III. CIRCUIT DESCRIPTIONS

74. Motor Circuit TT-122A/FG (fig. 45)

Power is applied to the synchronous motor through two 1-ampere fuses, F1 and F2. When POWER switch S3 is closed, current flows through the 3.75-microfarad (μf) part of capacitor C1 and the start winding. The coil of motor start relay K1 and the run winding of the motor are also energized. When the coil of relay K1 is energized, it closes its contact and places a 10-ohm resistor and a 5- μf capacitor in parallel with 3.75- μf capacitor of C1 that is in series with the start winding. This increases the effective capacity in series with the start winding and provides the initial

torque to start the armature rotating. As the armature gains speed, the current that flows through the motor (and also the coil of relay K1) decreases. When a predetermined current value is reached, relay K1 deenergizes and its contact opens. The start winding circuit remains completed through the 3.75- μf capacitor. The motor armature continues to accelerate until it reaches 3,600 rpm.

75. Motor Circuit TT-123A/FG (fig. 46)

Power is applied to the series-governed motor through two 1.6-ampere fuses. When POWER switch S3 is closed, current flows

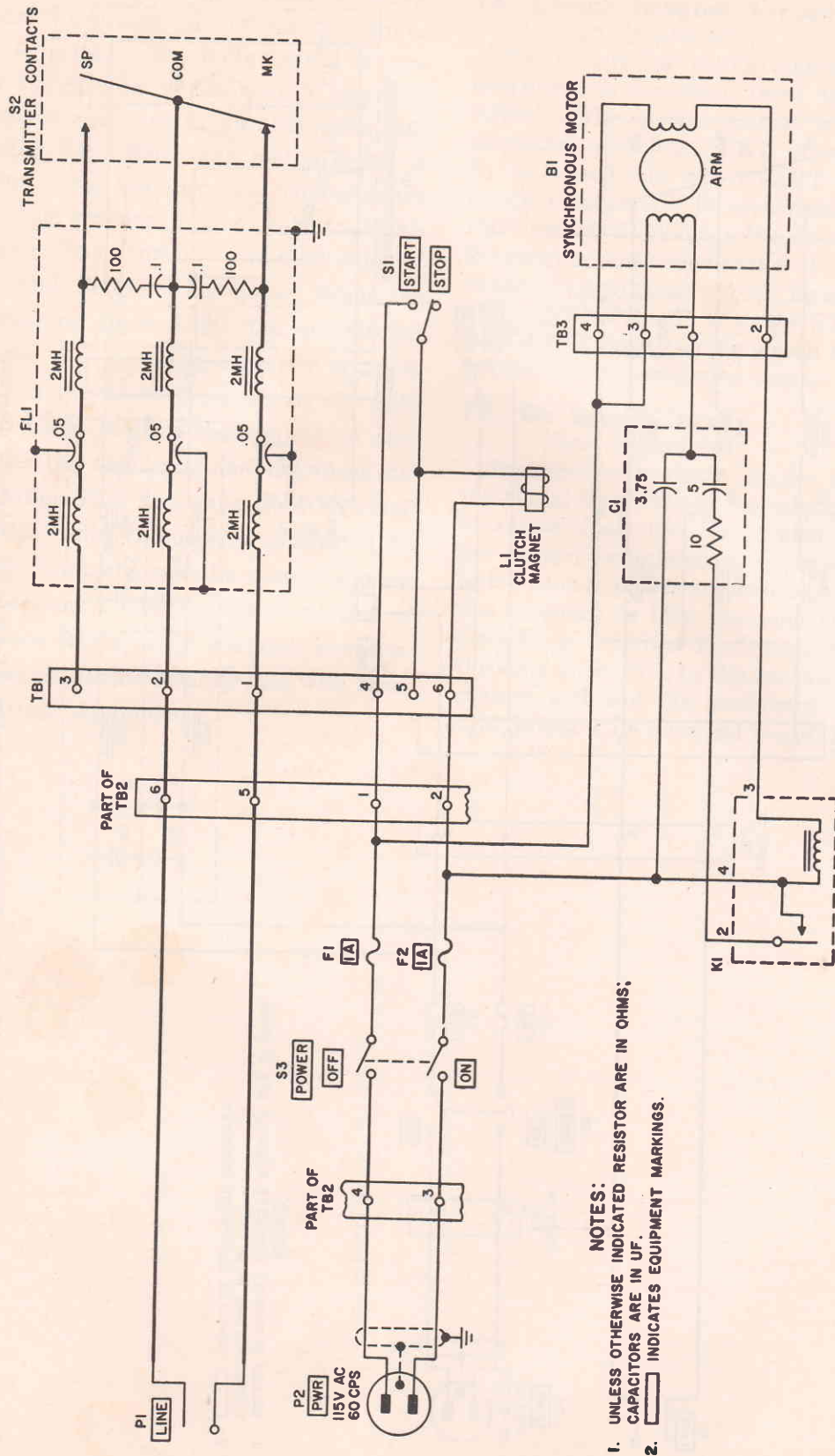

- NOTES:**
1. UNLESS OTHERWISE INDICATED RESISTOR ARE IN OHMS; CAPACITORS ARE IN UF.
 2.  INDICATES EQUIPMENT MARKINGS.

Figure 45. Distributor-transmitter TT-122A/FG. schematic diagram.

TM2277-45

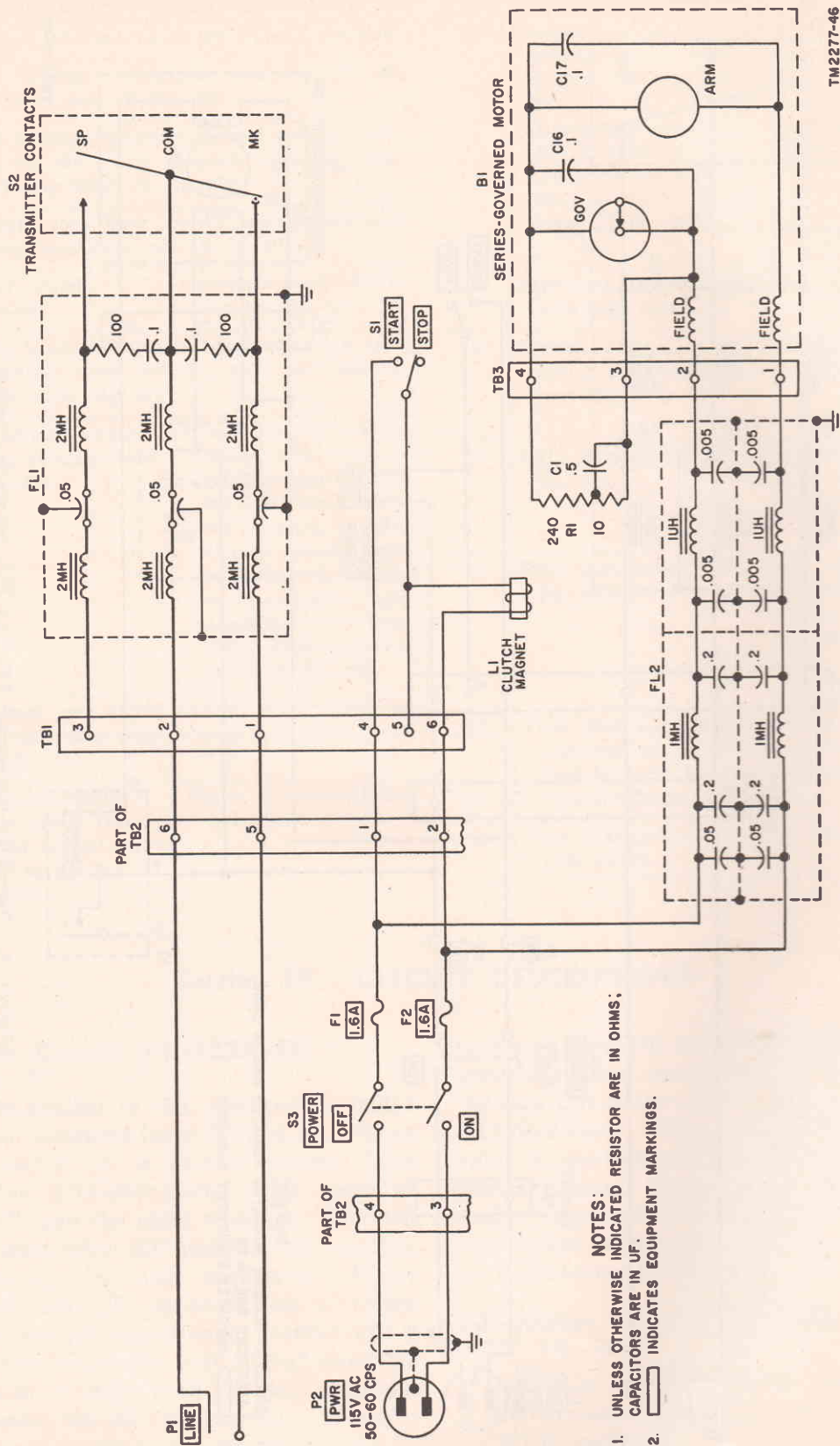

TM2277-46

Figure 46. Distributor-transmitter TT-123A/FG, schematic diagram.

- NOTES:
1. UNLESS OTHERWISE INDICATED RESISTOR ARE IN OHMS; CAPACITORS ARE IN UF.
 2. INDICATES EQUIPMENT MARKINGS.

thr
and
arr
tro
ern
ohr
bel
clo
mu
the
mo
for
Th
ohr
ren
cre
C1'
the
tat
R1
Th
cia

through filter FL2, the field coils, armature, and governor contacts and causes the motor armature to rotate. The motor speed is controlled by the opening and closing of the governor contacts that are in parallel with 250-ohm resistor R1. When the motor speed is below 3,600 rpm, the governor contacts are closed and the resistor is shorted out; maximum current flows through the field coils of the motor, and the speed increases. When the motor is running above 3,600 rpm, centrifugal force causes the governor contacts to open. This removes the short from across the 250-ohm resistor and reduces the amount of current through the field coils and the speed decreases. Filter FL2 and capacitors C16 and C17 suppress radio frequencies generated by the governor contacts and the motor commutator. Capacitor C1 and the 10-ohm portion of R1, suppresses arcing at the governor contacts. The suppression lessens interference with associated electronic equipment.

76. Clutch Magnet Circuit (figs. 45 and 46)

The circuit for clutch magnet L1 must be energized to transmit from the tape transmitter. The clutch magnet is controlled by stop-start switch S1. When stop-start switch S1 is closed (in the START position), the clutch magnet will be energized. When stop-start switch S1 is open, the clutch magnet will deenergize, and transmission stops. The clutch magnet is energized directly by ac input. When stop-start switch S1 is in the STOP or FEED RETRACT position, the clutch magnet circuit is open and transmission stops.

77. Dc Send Circuit (figs. 45 and 46)

Transmitter contacts S2 are in series with the signal line. When the camshaft is allowed to rotate (par. 69), the transmitter contacts are opened and closed in sequence and the selected code impulses are sent to the line. When the camshaft is idle, the send circuit is complete from terminal 2 of terminal board TB1 through filter FL1 to the movable transmitter contact bail and the stationary mark contact to terminal 1 of terminal board TB1.

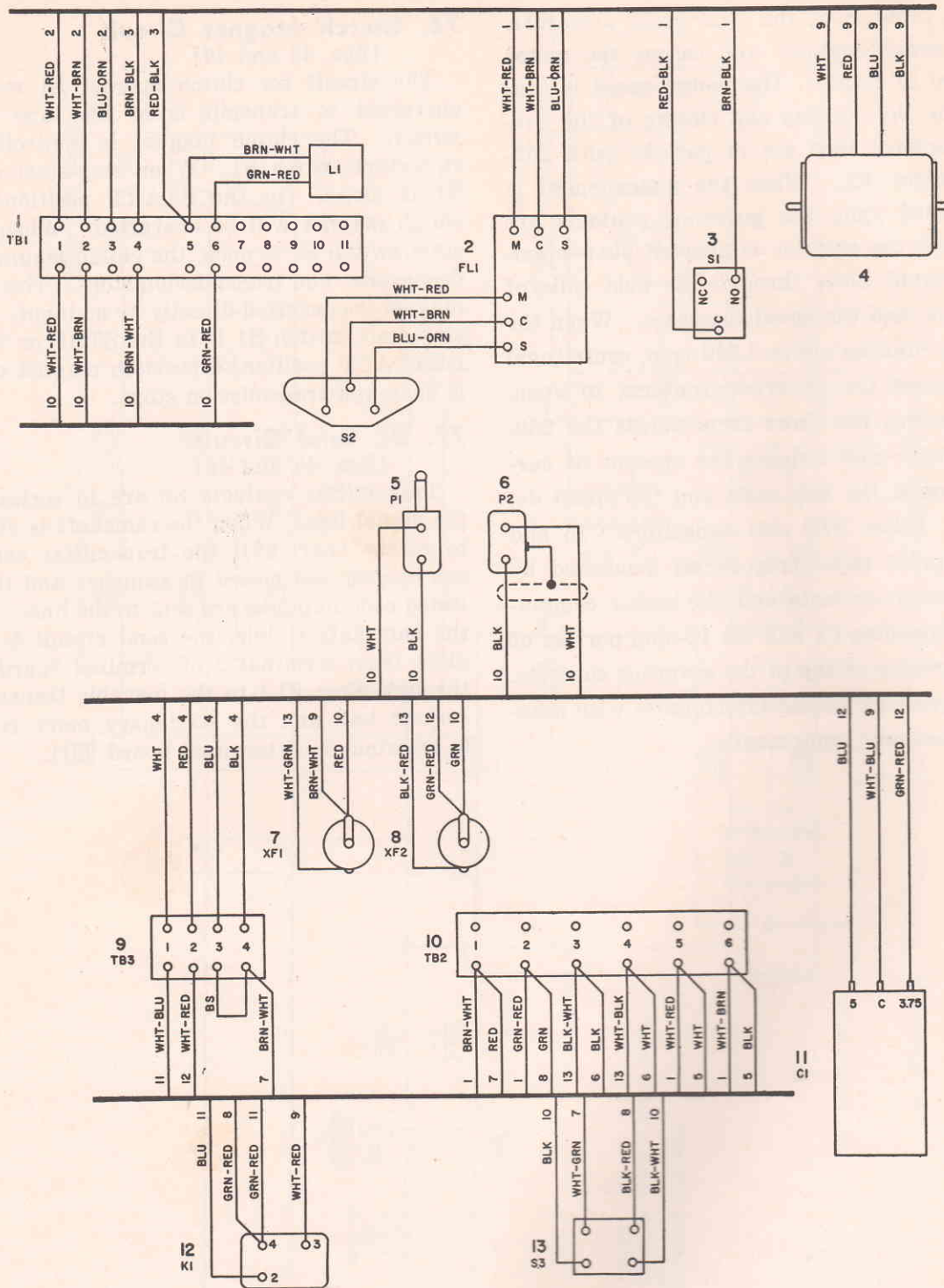

- NOTES:
1. THE SMALL NUMBER ON EACH WIRE (ADJACENT TO THE COMMON OR BASE LINE) CORRESPONDS TO THE LARGE NUMBER ADJACENT TO THE STATION TO WHICH THE WIRE RUNS.
 2. BS DENOTES BARE WIRE STRAP.
 3. DENOTES SHIELDED CONNECTIONS.

TM2277-47

Figure 47. Distributor-Transmitter TT-122A/FG, wiring diagram.

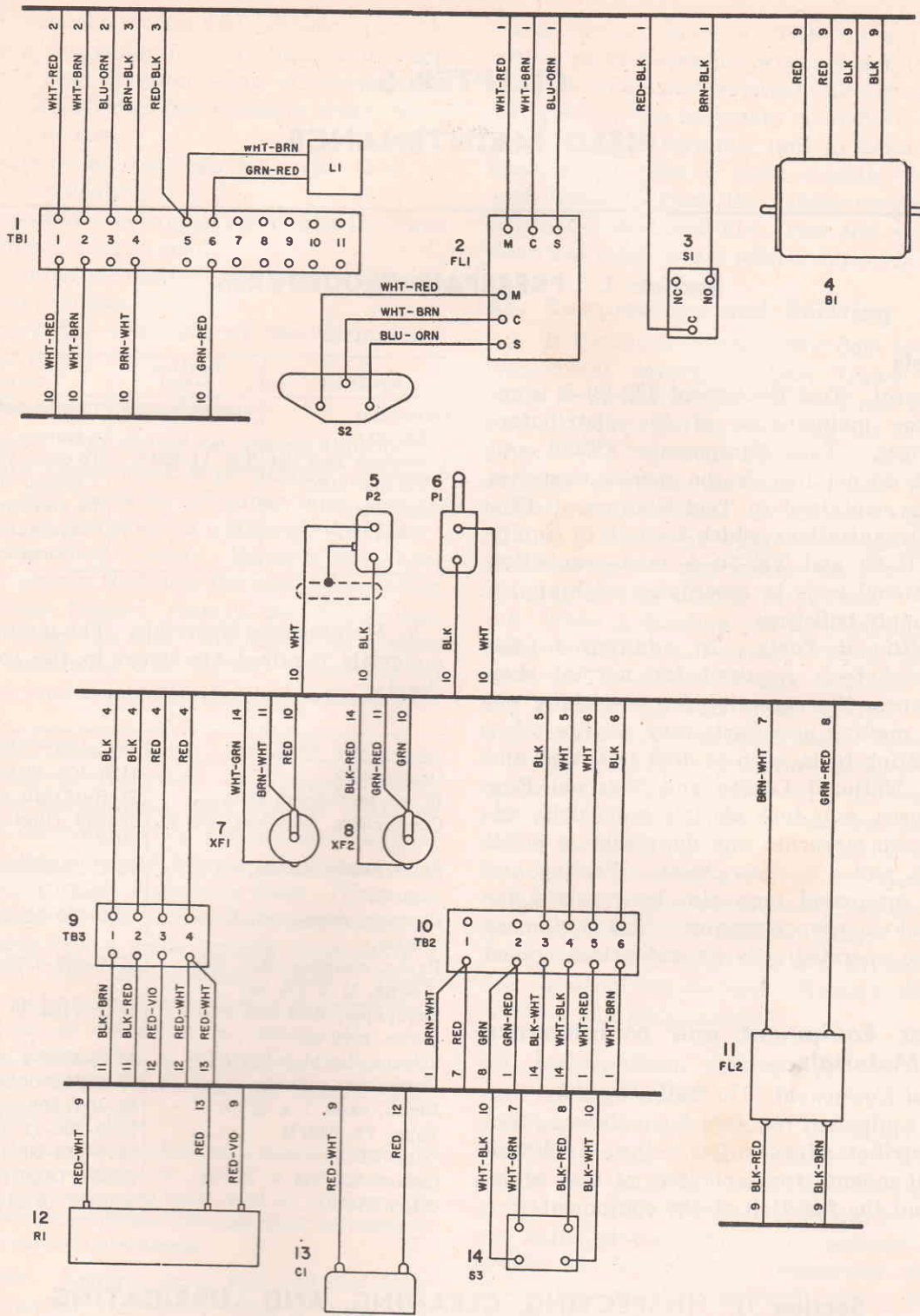

- NOTES:
1. THE SMALL NUMBER ON EACH WIRE (ADJACENT TO THE COMMON OR BASE LINE) CORRESPONDS TO THE LARGE NUMBER ADJACENT TO THE STATION TO WHICH THE WIRE RUNS.
 2.  DENOTES SHIELDED CONNECTIONS.

TM2277-48

Figure 48. Distributor-Transmitter TT-123A/FG, wiring diagram.

CHAPTER 5

FIELD MAINTENANCE

Section I. PREREPAIR PROCEDURES

78. Tools

a. General. Tool Equipment TE-50-B is required for maintenance of the distributor-transmitters. Tool Equipments TE-50 and TE-50-A do not include the special wrenches and gages contained in Tool Equipment TE-50-B. Organizations which have Tool Equipments TE-50 and TE-50-A may requisition the additional tools in accordance with appropriate supply bulletins.

b. Additional Tools. In addition to the above-listed tools required for normal shop maintenance, the necessity for reworking old parts or making new parts may require other metal cutting tools, such as drill sets, taps and dies for National Coarse and National Fine thread sizes, a 1/4-inch electric hand drill, adjustable tap wrenches and die stocks, a metal handsaw, and a 1/4-inch chisel. Welding and brazing equipment may also be required for occasional emergency repairs. This equipment should be operated only by authorized skilled personnel.

79. Test Equipment and Maintenance Materials

a. Test Equipment. The following chart lists the test equipment required for maintenance of the distributor-transmitter, the applicable technical manual for each item, of test equipment, and the function of the equipment:

Equipment	Technical manual	Function
Ohmmeter ZM-21/U	TM 11-2050A	To make dielectric tests.
Distortion Test Set TS-383*/CG.	TM 11-2217	To check the transmitted signal.
Multimeter ME-77/U		To measure voltage, current, and resistance.

b. Maintenance Materials. The maintenance materials required are listed in the following chart:

Item	Stock No.
Orangestick	5120-408-4036 (Fed)
Brush, toothbrush style	53-B-121610 (QMC)
Cheesecloth, bleached, 36 in. wide.	6Z1989 (SigC)
Cloth, emery, crocus, 9 x 11 in. sheets.	42-C-20420-50 (Ord C)
Cleaning compound, liquid form.	7930-395-9542 (Fed)
Paper, cleaning, Bell Seal Bond, 1/4 x 2 1/2 in.	7530-488-2352 (Fed)
Sandpaper, flint No. 0000, 9 in. x 10 in.	42-P-1154-10 (Ord C)
Solvent, dry cleaning (SD)	51-S-4385-1 (QMC)
Compound, antiseize	52-2724.5000.080 (CE)
Brush, sash, 1 x 5/8 in.	38-4567.300.200 (CE)
Tape TL-636/U	5970-296-1175 (Fed)
Tape TL-83	5970-184-2003 (Fed)
Grease, KS7471	6G650 (SigC)
Oil, KS7470	6G1325 (SigC)

Section II. INSPECTING, CLEANING, AND LUBRICATING

80. Inspection Procedure

When the distributor-transmitter arrives at a repair shop for maintenance, the first step is to determine the nature and extent of the re-

pairs required. The inspection should include the following checks:

a. Examine the general condition of the covers.

- b. See that the machine is complete (par. 5).
- c. Turn the motor over by hand and check for motor bind or visual signs of overheating.
- d. Check all gears for excessive wear, backlash, or looseness.
- e. Examine all bearings for wear, bind, or signs of overheating.
- f. Inspect all mechanical assemblies for signs of damage during transit.
- g. Examine all castings for signs of cracks or broken portions.
- h. Check the condition of the wiring and electrical cords.

81. Cleaning Procedures

The equipment should be cleaned thoroughly before any repair work is performed. Remove all dirt, grit, particles of paper tape, and oil or grease as described in *a* through *d* below.

a. Motor Dust Cover. Remove the three shoulder screws that hold the motor dust cover to the base frame; remove the motor dust cover. Clean the outer surfaces with a cloth slightly moistened with water. To remove oil or grease stains, moisten the cloth with solvent (SD).

b. Tape Transmitter. Remove the tape transmitter as described in paragraph 93a. Clean the mechanisms with solvent (SD) or cleaning compound. Do not immerse any of the ball bearings or bronze oil-impregnated sleeve bearings in a cleaning fluid. They are self-lubricating and immersion would be harmful. Parts with a black metallic finish have a protective, corrosion-resistant finish. *These parts should never be dipped in a cleaning fluid longer than is necessary to remove the dirt. Extended immersion is harmful to the protective finish.* After such cleaning, lightly spray these parts with oil.

Note. Do not use gasoline as a cleaning fluid. If an emergency requires the use of a substitute for the recommended cleaning fluids, fuel oil (DF-A) may be used until the proper cleaning fluid is obtained. Never use carbon tetrachloride.

c. Motor. Remove loose dust and dirt from the exterior of the motor with a clean, dry sash brush. Use a cloth dampened with solvent (SD) to remove oil and gummy deposits. Be careful not to damage the wiring.

d. Base Frame and Associated Parts. Remove loose dust, dirt, and tape particles with

a sash brush. Remove oil and grease deposits with a cloth moistened with solvent (SD). If the base frame and terminal unit are extremely dirty, it may be necessary to remove the components of the terminal unit to clean the unit thoroughly. Use a cloth slightly dampened with water to clean the rubber-covered cords. Brush the dust and dirt from the wiring and electrical components with a dry sash brush.

82. Rustproofing and Painting

a. If the finish on the motor dust cover, tape transmitter covers, or base frame becomes badly scratched or scarred, rust and corrosion may be prevented by touching up bared surfaces. Use No. 0000 sandpaper to clean the surfaces down to the bare metal. Obtain a bright, smooth finish. Do not use steel wool; minute particles of steel wool can enter the electrical parts and cause harmful internal shorting and grounding of circuits.

b. When a touchup job is necessary, apply paint with a small brush. When numerous scars and scratches warrant complete repainting, remove the unit from service. Remove slight rust from corroded metal by cleaning with solvent (SD). In severe cases, it may be necessary to use solvent (SD) to soften the rust and then sandpaper to complete the preparation for painting. Place protective masking in advance, over all areas where paint is not required or where it may cause damage. Then spray paint over the entire surface. The paint to be used will be authorized in accordance with existing regulations. Restore moisture-proofing and fungiproofing.

83. Lubrication, Assembly, and Operational Test

When the components are thoroughly cleaned (par. 81), all parts that are susceptible to wear should be examined carefully for traces of excessive wear. Worn parts should be replaced and adjusted according to instructions in paragraphs 88 through 105. Particular attention should be given to gear teeth, sleeve bearings and shafts, ball bearings, and surfaces of cams and associated levers.

a. Lubrication. After replacement of worn parts, lubricate each mechanical assembly as described in paragraph 34. If evidence of overheating or wear is discovered at points

that are normally self-lubricating (oil-impregnated parts), restore lubrication to these parts by immersion for 20 minutes in oil, lubricating, Signal Corps stock No. 6G1325, heated to 140° F.

b. Assembly. As each of the disassembled mechanisms is lubricated, replace it on the unit. Renew the coating of antiseize compound on any steel screws that are to be screwed into aluminum or magnesium castings. This coating is necessary because steel screws, unless coated with this compound, have a tendency to seize in the casting, making future removal of the screws very difficult.

c. Operational Test. After the distributor-transmitter is assembled, an operational test must be made of the complete unit. Prepare the distributor-transmitter for testing and test as described in paragraph 19. If the distributor-transmitter operates improperly, locate the fault by using the troubleshooting chart (par. 87). If the distributor-transmitter operates properly, it should be subjected to a prolonged test run before being installed into the communication system. Under normal conditions, equipment should be test run for at least 1 hour to minimize the possibility of failure after installation.

Section III. TROUBLESHOOTING AT FIELD MAINTENANCE LEVEL

84. General

The troubleshooting information presented in this section consists of a series of operational, mechanical, and electrical checks to be performed by qualified maintenance personnel. The procedure is designed to isolate a specific part, a maladjustment, or an electrical component that is causing trouble in the distributor-transmitter.

85. Localizing Electrical Troubles

Some electrical troubles may be located visually. Others require methodical testing of each circuit (fig. 47 or 48), and testing of individual components in each circuit. Be sure that the power cord plug is pressed firmly into the power outlet and the signal cord plug into the associated jack. If the motor fails to operate, with the POWER switch in the ON position, check the two fuses at the rear of the base frame (fig. 4). Check the power output at the power outlet.

86. Localizing Mechanical Troubles

Most mechanical troubles may be located by manually turning the motor shaft and carefully observing the sequence of operations in paragraphs 70 through 74. If this procedure is to be followed, hold the clutch magnet armature in the energized position to permit the distributor-transmitter camshaft to rotate.

87. Troubleshooting Chart

The most common troubles, probable causes, and corrective actions are listed in the chart below. Both electrical and mechanical troubles are listed, but they are not separated into groups because some faulty conditions may be caused by either type of trouble. Several probable causes are listed for most troubles, but they rarely occur at the same time. The troubleshooter must determine by a thorough check of each item which one causes the particular trouble under investigation. The troubles listed are common to both distributor-transmitters unless otherwise indicated.

Symptom	Probable cause	Correction
Motor fails to start.	Power input fuse blown.	Replace fuse (fig. 4).
	Failure of power source.	Correct defect or use another power source.
	Governor spring loose or broken (TT-123A/FG).	Repair or replace spring (par. 92).
	Governor electrical contacts dirty or pitted (TT-123A/FG).	Clean, burnish, or replace contacts (par. 92).
	Open field or armature winding.	Replace motor (par. 89).

Symptom	Probable cause	Correction
Motor runs but speed is erratic.	Brushes badly worn (TT-123A/FG).	Replace brushes (par. 91).
Distributor-transmitter causes clicks and noises in local radio equipment.	Governor electrical contacts dirty or pitted (TT-123A/FG).	Clean, burnish, or replace contacts (par. 92).
Distributor-transmitter camshaft does not rotate.	Improper grounding.	Ground distributor-transmitter (par. 12).
Camshaft rotates but distributor-transmitter cannot transmit code signals to the line.	Filter assemblies in motor circuit open.	Check filter circuits and replace if defective (fig. 45 or 46, par. 91b).
Distributor-transmitter transmits garbled copy.	Clutch magnet L1 not energized.	Check tape-out linkage adjustment (par. 56). Check clutch magnet L1 circuit (par. 76c).
Distributor-transmitter transmits only the blank combination.	Clutch magnet armature does not clear stop lever.	Check armature eccentric stud and laminated core adjustments (pars. 46 and 47).
Camshaft rotates continuously.	Friction clutch dry or out of adjustment.	Check lubricant and adjust spring tension (pars. 34d and 57).
Tape does not feed properly.	Signal circuit shorted.	Check circuit connections and the signal circuit (par. 16). Check current supply.
	Line current not furnished by associated equipment.	Clean contacts and adjust (par. 28c(3) and 48).
	Transmitter contacts dirty or out of adjustment.	Replace spring (par. 100).
	Transmitter contact bail spring weak or broken.	Check friction clutch lubricant and adjust spring tension (par. 34d and 57).
	Friction clutch dry or out of adjustment.	Clean contacts and adjust (par. 28c(3) and 48).
	Transmitter contacts dirty or out of adjustment.	Replace spring (par. 100).
	Transmitter contact bail spring weak.	Eliminate cause of bind and readjust if necessary (par. 54).
	Bind in the sensing levers or selector levers.	Clean or adjust contacts (par. 28c(3) and 48).
	Transmitter contacts dirty or out of adjustment.	Adjust comb (par. 45).
	Selector lever comb out of adjustment.	Replace springs (par. 97).
	Code sensing lever spring weak.	Readjust comb to eliminate bind (par. 45).
	Code sensing levers binding.	Clear short, replace switch (par. 96).
	Stop-start switch shorted.	Adjust tape-out linkage (par. 56).
	Tape-out linkage out of adjustment.	Eliminate cause of bind; readjust selector lever comb if necessary (par. 45).
	Camshaft stop lever binding.	Replace spring (par. 101).
	Clutch magnet armature spring weak or broken.	Replace spring (par. 98).
	Stop lever spring weak or broken.	Repair or replace if necessary (par. 97).
	Feed tape claw bent, broken, or binding.	Replace springs (par. 97).
	Tape feed lever spring or feed claw spring weak.	Straighten tape feed lever and engage it with the tape feed claw (pars. 97 and 98).
	Tape feed lever bent out of engagement with the tape feed claw.	

Section IV. REMOVAL AND REPLACEMENT

88. General

This section describes the procedures required to completely overhaul the distributor-transmitter. When disassembling the various parts and assemblies, disconnect the power and signal line connections. When reassembling the components, be sure that mating gears, the clutch assembly, and mechanical linkages are engaged before tightening the holding screws or bolts. Do not tighten screws, nuts, or bolts excessively. Steel screws should be coated with antiseize compound, before they are inserted into magnesium or aluminum castings. If springs are removed, tag them to identify their location.

Caution: Dangerous voltages exist in this equipment. Turn off the power before making any connections or replacing any parts within the equipment.

89. Removal and Replacement of Motor (fig. 49)

a. Removal.

- (1) Remove the three shoulder screws (1, fig. 63) that hold the motor dust cover (8 or 9) to the base frame (24); remove the motor dust cover.
- (2) Remove the four machine screws (1, fig. 61), lockwashers (2 and 5), and flat washers (3) that hold the bottom plate (4) to the base frame; remove the bottom plate.
- (3) Disconnect the leads on the motor cable from terminal board TB3; tag the leads. On the TT-123A/FG, remove the machine screw and lockwasher that hold the grounding lead of the motor cable to the base frame.
- (4) Remove the four machine screws (1, fig. 50 or 51) and lockwashers (2) and flat washers (3) that hold the motor to the base frame; remove the motor.

b. Changing Drive Gearset.

- (1) Remove the motor as described in *a* above.
- (2) Remove the machine screw (14, fig. 63) and lockwasher (15) that hold the motor driven gear (16) to the power

shaft (23); remove the motor driven gear.

- (3) Remove the machine screw (4, fig. 50 or 51) and lockwasher (5) that hold the worm gear (6) to the rear end of the motor shaft; remove the worm gear.
- (4) Install the alternate worm gear on the motor shaft; secure it to the motor shaft with the machine screw and lockwasher that retained the worm gear being replaced.
- (5) Install the alternate motor driven gear on the power shaft; secure it with the machine screw and lockwasher that retained the motor-driven gear being replaced.

c. Replacement.

- (1) Position the motor on the base frame; secure with four machine screws (1, fig. 50 or 51) and lockwashers (2) and flat washers (3).
- (2) Reconnect the motor cable to terminal board TB3.
- (3) Position the bottom plate on the base frame; secure with four machine screws (1, fig. 61), lockwashers (2 and 5) and flat washers (3).
- (4) Position the motor dust cover on the base frame; secure with the three shoulder screws (1, fig. 63).
- (5) Adjust the drive gear set as described in paragraph 40.

90. Disassembly and Reassembly of Synchronous Motor (TT-122A/FG) (fig. 50)

a. Disassembly.

- (1) Remove the motor as described in paragraph 89a.
- (2) Remove the machine screw (4) and lockwasher (5) that hold the worm gear (6) to the shaft of the rotor (29); remove the worm gear.
- (3) Support the rotor shaft and drive the pin (7) from the shaft.
- (4) Remove the two setscrews (8) that hold the motor shaft knob (9) to the

shaft of the rotor; remove the motor shaft knob.

- (5) Remove the four machine screws (10) and lockwashers (11) that hold the cover (18) to the stator (30).
- (6) Remove the three machine screws

(12) and lockwashers (13) that hold the end plate (14) to the cover (18); remove the end plate, flat washer (15), thrust pad (16), and flat washer (17) from the end of the shaft of the rotor.

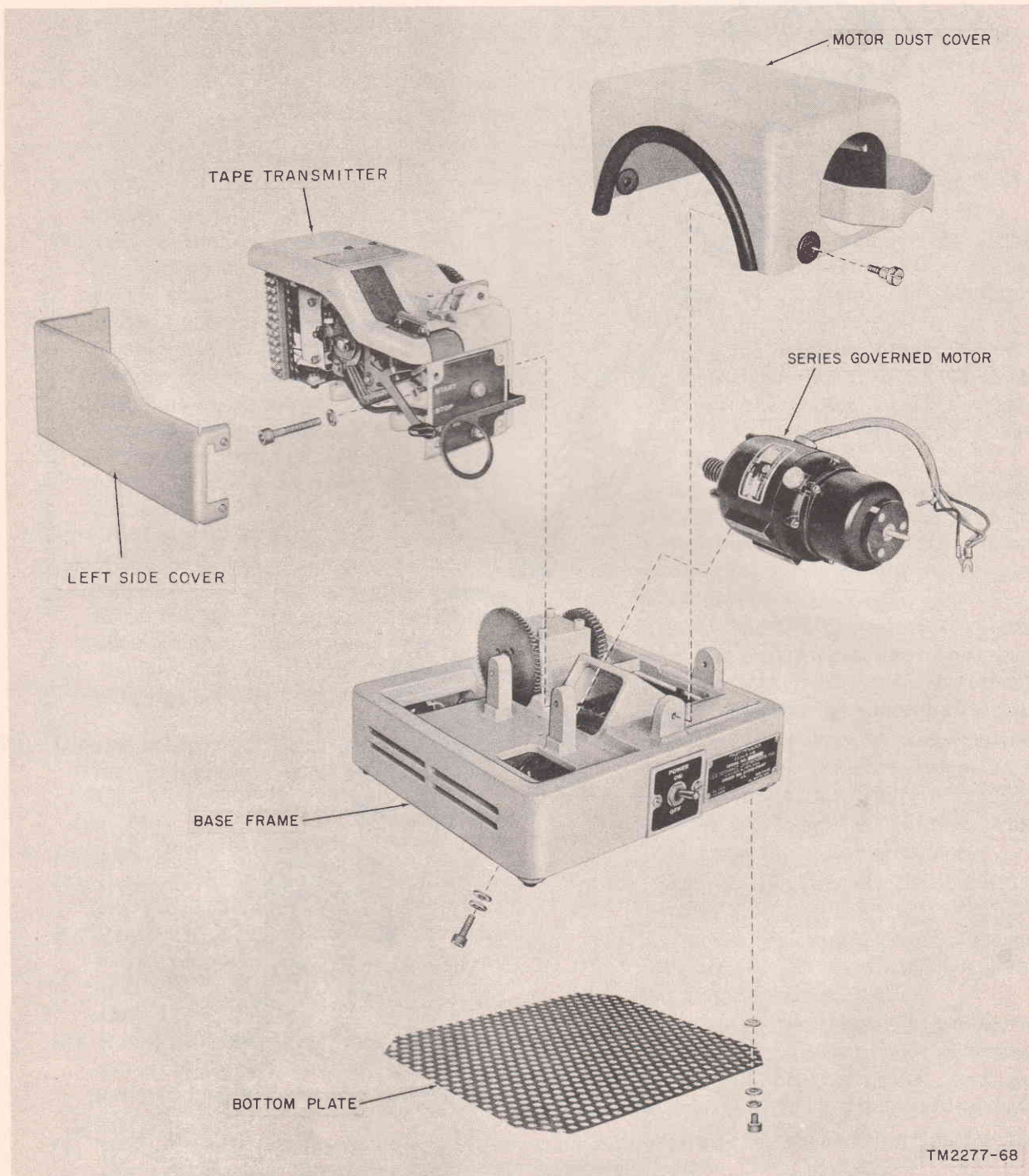
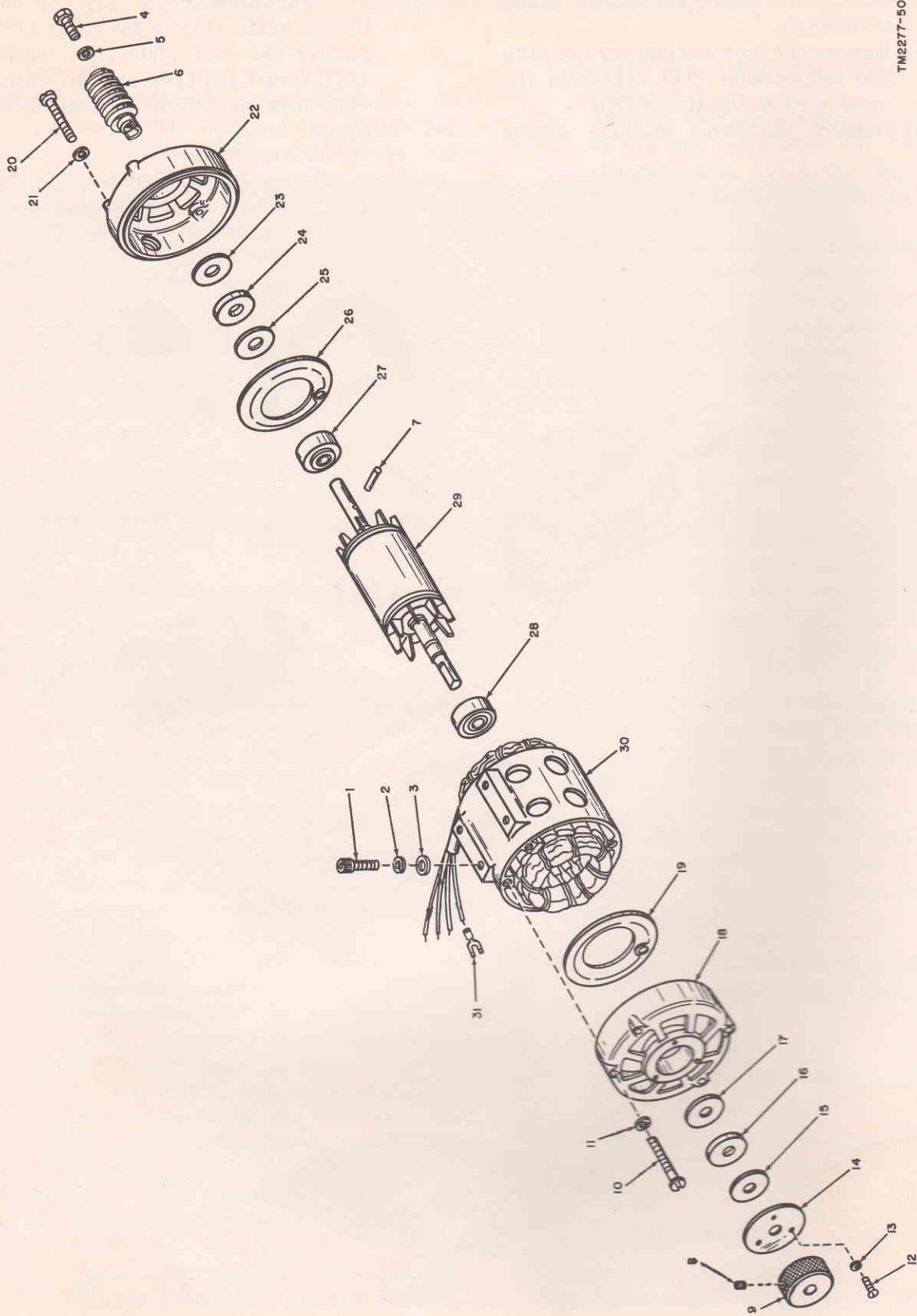

Figure 49. Major components, exploded view.



TM2277-50

Figure 50. Synchronous motor, exploded view.

1	Machine screw, 10026	16	Thrust pad
2	Lockwasher, 10431	17	Flat washer
3	Flat washer, 10481	18	Cover
4	Machine screw, 56124	19	Air guide
5	Lockwasher, 10438	20	Machine screw
6	Worm gear, 52105	21	Lockwasher
7	Pin, 50359	22	Cover
8	Setscrew, 10211	23	Flat washer
9	Motor shaft knob, 54217	24	Thrust pad
10	Machine screw	25	Flat washer
11	Lockwasher	26	Air guide
12	Machine screw	27	Ball bearing
13	Lockwasher	28	Ball bearing
14	End plate	29	Rotor
15	Flat washer	30	Stator
		31	Terminal, 20706

Note. Items 10 through 30 are part of 56854A.

Figure 50—Continued

- (7) Remove the four machine screws (20) and lockwashers (21) that hold the cover (22) to the stator (30); remove the cover and slide the flat washer (23), thrust pad (24), flat washer (25), and air guide (26) off the shaft of the rotor.
- (8) Remove the ball bearings (27 and 28) from each end of the shaft of the rotor. Remove the rotor (29) from the stator (30).

b. Reassembly.

- (1) Reassemble the motor as indicated in figure 50; the sequence for assembling the parts is the reverse of the disassembly sequence.
- (2) Replace the motor as described in paragraph 89c.

91. Disassembly and Reassembly of Series-Governed Motor (TT-123A/FG)

(fig. 51)

a. Disassembly.

- (1) Remove the motor as described in paragraph 89a.
- (2) Remove the machine screw (4) and lockwasher (5) that hold the worm gear (6) to the armature shaft; remove the worm gear.
- (3) Remove the pin (7) from the motor armature shaft; remove the grease seals (8 and 9) from the motor armature shaft.
- (4) Remove the four machine screws (10) and lockwashers (11) that hold the cover (12) to the motor (54); re-

- move the cover. Remove the thrust pad (13), lockwasher (14), and ball bearing (15) from the armature shaft.
- (5) Remove the setscrew (16) that holds the motor governor target (17) to the shaft of the motor speed governor base (41); remove the motor governor target (17).
- (6) Remove the two machine screws (18) and lockwashers (19) that hold the motor governor cover (20) to the motor (54); remove the motor governor cover.
- (7) Remove the two setscrews (21) that hold the motor speed governor base (41) to the motor armature shaft; remove the assembled motor governor.
- (8) Remove the governor worm spring (22) and the governor worm (23) from the motor governor.
- (9) Remove the electrical contact brush (24) from the motor governor.
- (10) Remove the two electrical contact brushes (25).
- (11) Remove the motor brush shields (42) and brush caps (43); remove the motor brushes (44).
- (12) Remove the armature (48) from the motor (54); remove the flat washer (45), ball bearing (46), and flat washer (47) from the armature shaft.

b. Removal and Replacement of Motor Capacitors.

- (1) Disassemble the series-governed mo-

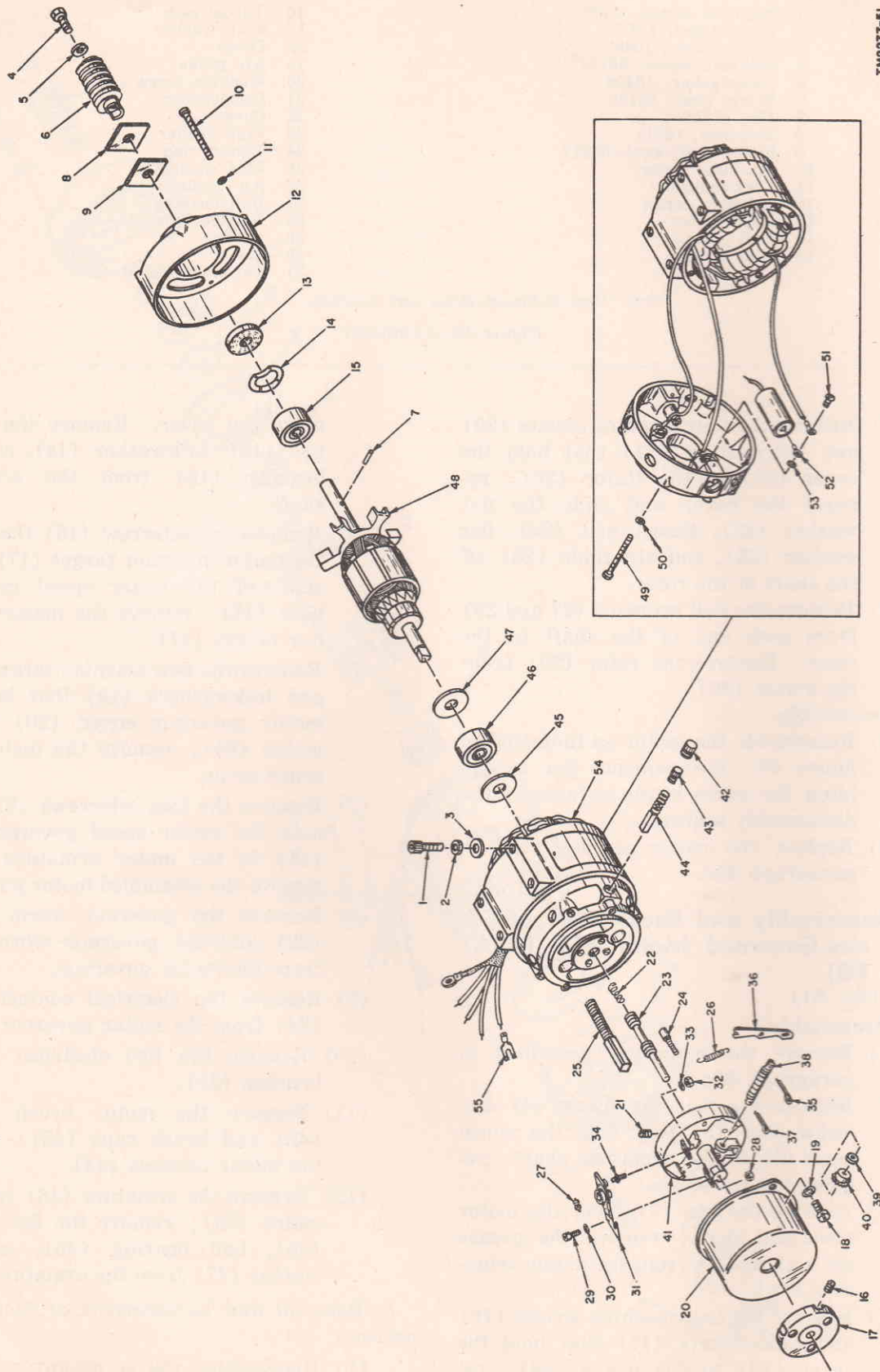

TM2277-51

Figure 51. Series-governed motor, exploded view.

br
gl
ch

TA

1	Machine screw, 10024	28	Self-locking hexagonal nut, 10500
2	Lockwasher, 10431	29	Machine screw, 10001
3	Flat washer, 10481	30	Lockwasher, 10403
4	Machine screw, 56124	31	Electrical contact, 50281A
5	Lockwasher, 10406	32	Plain hexagonal nut, 10507
6	Worm gear, 50350	33	Lockwasher, 10404
7	Pin, 50359	34	Electrical contact, 50338
8	Grease seal, 50949	35	Cotter pin, 10800
9	Grease seal, 50949	36	Governor adjustment lever, 50301
10	Machine screw	37	Cotter pin, 10800
11	Lockwasher	38	Governor adjustment screw 50299
12	Cover	39	Flat washer, 50148
13	Thrust pad	40	Motor governor adjustment gear, 50278A
14	Lockwasher	41	Motor speed governor base, 51249A
15	Ball bearing, 10760	42	Brush shield, 51155
16	Setscrew, 10204	43	Brush cap
17	Motor governor target, 50303A	44	Brush, 56834A
18	Machine screw, 10321	45	Flat washer
19	Lockwasher, 10412	46	Ball bearing, 10760
20	Motor governor cover, 50311	47	Flat washer
21	Setscrew, 10203	48	Armature, 51187
22	Governor worm spring, 51855	49	Machine screw
23	Governor worm, 56555A	50	Lockwasher
24	Electrical contact brush, 51154A	51	Machine screw
25	Electrical contact brush, 51543A	52	Capacitor, 20205
26	Adjustment lever spring, 50334	53	Lockwasher
27	Grooved pin, 50302	54	Motor, 51696 (includes items 10-15 and 42-53)
		55	Terminal, 20706

Figure 51—Continued

tor as described in *a*(1), (5), (6), (7), and (11) above.

- (2) Remove the four machine screws (49) and lockwashers (50) that hold the cover to the motor; carefully separate the cover and motor.
- (3) Unsolder and disconnect the capacitor (52) from the brush holder bushing in the cover. Remove the machine screw (51) that holds the capacitor (52) to the cover; remove the capacitor and lockwasher (53).
- (4) Reassemble the capacitors in the motor as indicated in figure 51; the sequence for assembling the parts is the reverse of the disassembly sequence.

c. Reassembly. Check the motor governor brushes (44). Clean them if they are dirty or glazed; replace them if they are worn or chipped.

- (1) Reassemble the motor as indicated in figure 51; the sequence for assembling the parts is the reverse of the disassembly sequence.
- (2) Replace the motor as described in paragraph 89*c*.
- (3) Adjust the motor speed as described in paragraph 14.

92. Disassembly and Reassembly of Motor Governor (fig. 51)

a. Disassembly.

- (1) Remove the motor governor from the motor as described in paragraph 91*a*(5) through (7).
- (2) Remove the spring (26) from the governor adjustment lever (36) and from the grooved pin (27); remove the grooved pin.
- (3) Remove the self-locking hexagonal nut (28), machine screw (29), and lockwasher (30) that hold the electrical contact (31) to the motor speed governor base (41); remove the electrical contact.
- (4) Remove the plain hexagonal nut (32) and lockwasher (33) that hold the electrical contact (34) to the motor speed governor base (41); remove the electrical contact.
- (5) Remove the cotter pin (35) that holds the governor adjustment lever (36) to the governor adjustment screw (38); remove the governor adjustment lever.
- (6) Remove the cotter pin (37) from the opposite end of the governor adjust-

ment screw (38); turn out the governor adjustment screw from the mounting on the motor speed governor base (41). Catch the flat washer (39) and the motor governor adjustment gear (40) as they fall from the motor speed governor base.

b. Reassembly. If necessary, clean or burnish the governor electrical contact points before reassembly. Remove any built-up or pitted portions of the contacts with a contact file. Do not remove any more metal than is necessary.

- (1) Reassemble the motor governor as indicated in figure 51; the sequence for assembling the parts is the reverse of the disassembly sequence.
- (2) Replace the series-governed motor as described in paragraph 89c.
- (3) Adjust the speed of the series-governed motor as described in paragraph 14.

93. Removal and Replacement of Tape Transmitter (fig. 49)

a. Removal.

- (1) Snap off the left side cover (6, fig. 52) of the tape transmitter.
- (2) Disconnect the leads of the base electrical components from terminal board TB1; tag the leads.
- (3) Remove the two machine screws (1, fig. 60) and lockwashers (2) that hold the tape transmitter frame to the base frame; remove the tape transmitter.

b. Replacement.

- (1) Position the tape transmitter on the base frame, carefully engaging the distributor-transmitter driven gear with the driving gear on the power shaft. Secure with the two machine screws (1, fig. 60) and lockwashers (2).
- (2) Connect the leads of the base electrical components to terminal board TB1.
- (3) Install the left side cover (6, fig. 52).
- (4) Align the distributor-transmitter driving gear and driven gear as described in paragraphs 41 and 42.

94. Disassembly and Reassembly of Tape Transmitter Covers (fig. 52)

a. Disassembly.

- (1) Remove the tape transmitter from the base frame as described in paragraph 93a.
- (2) Remove the two machine screws (2), lockwashers (3), bushings (4), and grommets (5) that hold the front plate (6) to the tape transmitter frame; remove the front plate.
- (3) Remove the four machine screws (7), lockwashers (8), bushings (9), and grommets (10) that hold the inside cover (11) to the tape transmitter frame; remove the inside cover.
- (4) Remove the setscrew (12) that holds the tape cover latch stud (13) to the tape cover bracket (30); remove the tape cover latch stud, tape cover latch (14); and tape cover latch spring (15).
- (5) Remove the pin (16) that holds the tape cover (21) to the tape cover bracket (30); remove the tape cover spring (17) and the assembled tape cover and tape guide (20).
- (6) Remove the two machine screws (18) and setscrews (19) that hold the tape guide (20) to the tape cover (21); remove the tape guide.
- (7) Remove the two machine screws (22), lockwashers (23), machine screw (24), and lockwasher (25) that hold the top cover (33) to the frame; remove the top cover. Remove the two setscrews (26 and 27) from the top cover.
- (8) Remove the two machine screws (28) and lockwashers (29) that hold the tape cover block (30) to the top cover (33); remove the tape cover bracket and shims (31 and 32).

b. Reassembly.

- (1) Reassemble the tape transmitter cover as indicated in figure 52; the sequence for assembling the parts is the reverse of the disassembly sequence.
- (2) Adjust the tape cover and top cover

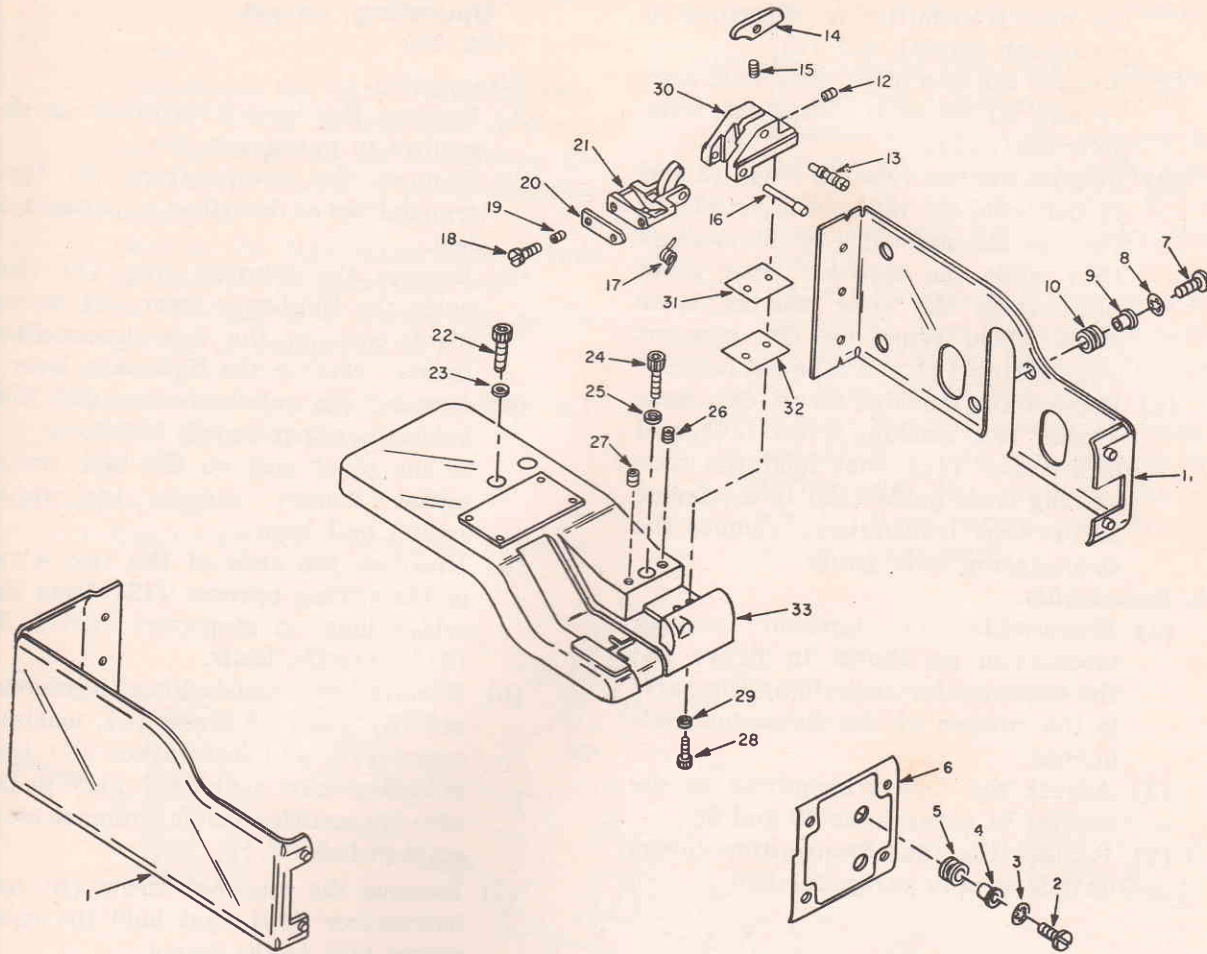

TM2277-52

- | | | | |
|----|--------------------------------|----|--------------------------|
| 1 | Machine screw, 10357 | 17 | Tape cover spring, 56324 |
| 2 | Lockwasher, 10403 | 18 | Machine screw, 52884 |
| 3 | Bushing, 52860 | 19 | Setscrew, 10221 |
| 4 | Grommet, 20725 | 20 | Tape guide, 52809 |
| 5 | Front plate, 59711 | 21 | Tape cover, 57209 |
| 6 | Outside cover, 53796A | 22 | Machine screw, 10003 |
| 7 | Machine screw, 10393 | 23 | Lockwasher, 10429 |
| 8 | Lockwasher, 10403 | 24 | Machine screw, 10006 |
| 9 | Bushing, 52860 | 25 | Lockwasher, 10429 |
| 10 | Grommet, 20725 | 26 | Setscrew, 10224 |
| 11 | Inside cover, 53795 | 27 | Setscrew, 10224 |
| 12 | Setscrew, 10201 | 28 | Machine screw, 10004 |
| 13 | Tape cover latch stud, 53952 | 29 | Lockwasher, 10421 |
| 14 | Tape cover latch, 57204 | 30 | Tape cover block, 57208A |
| 15 | Tape cover latch spring, 57203 | 31 | .002-inch shim, 57201 |
| 16 | Pin, 57214 | 32 | .005-inch shim, 57202 |
| | | 33 | Top cover, 59636A |

Figure 52. Tape transmitter covers, exploded view.

as described in paragraphs 50 through 55.

- (3) Replace the tape transmitter as described in paragraph 93b.

95. Disassembly and Reassembly of Tape-Out Sensing Mechanism (fig. 53)

a. Disassembly.

- (1) Snap off the outside cover and remove

the front plate and top cover from the tape transmitter as described in paragraph 94a(2) and (8).

- (2) Remove the two plain hexagonal nuts (1 and 2) from the tape-out lever pivot shaft (5).
- (3) Remove the two retainer rings (3 and 4) that hold the tape-out lever (7) in place on the tape-out lever pivot shaft (5); slide the tape-out lever pivot shaft from the code sensing lever guide (12), removing the tape-out lever spring (6) and tape-out lever.
- (4) Remove the machine screw (8), lockwasher (9), machine screw (10), and lockwasher (11) that hold the code sensing lever guide (12) to the frame of the tape transmitter; remove the code sensing lever guide.

b. Reassembly.

- (1) Reassemble the tape-out sensing mechanism as shown in figure 53; the sequence for assembling the parts is the reverse of the disassembly sequence.
- (2) Adjust the tape transmitter as described in paragraphs 49 and 56.
- (3) Replace the tape transmitter covers as described in paragraph 94b.

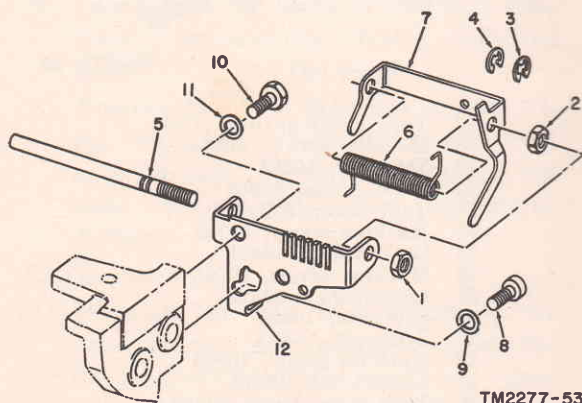

- 1 Plain hexagonal nut, 10504
- 2 Plain hexagonal nut, 10504
- 3 Retainer ring, 10969
- 4 Retainer ring, 10969
- 5 Tape-out lever pivot shaft, 52718
- 6 Tape-out lever spring, 53156
- 7 Tape-out lever, 52824
- 8 Machine screw, 10003
- 9 Lockwasher, 10429
- 10 Machine screw, 10398
- 11 Lockwasher, 10429
- 12 Code sensing lever guide, 52861

Figure 53. Tape-out sensing mechanism, exploded view.

96. Disassembly and Reassembly of the Operating Levers

(fig. 54)

a. Disassembly.

- (1) Remove the tape transmitter as described in paragraph 93a.
- (2) Remove the covers from the tape transmitter as described in paragraph 94a.
- (3) Remove the retainer ring (1) that holds the tight-tape lever (2) to the pivot post on the tape transmitter frame; remove the tight-tape lever.
- (4) Remove the retainer ring (3) that holds the upper switch bail lever (4) to the pivot post on the tape transmitter frame; remove the upper switch bail lever.
- (5) Unsolder the ends of the two wires in the wiring harness (12) from the solder lugs on stop-start switch S1 (11); tag the leads.
- (6) Remove the self-locking hexagonal nut (5), machine screw (6), machine screw (7), and lockwasher (8) that hold stop-start switch S1 (11) to the tape transmitter frame; remove stop-start switch S1.
- (7) Remove the machine screw (9) and lockwasher (10) that hold the cable clamp (13) to the frame.
- (8) Disconnect the terminal lugs of the wires at the other end of the wiring harness from the terminal board; remove the wiring harness and the cable clamp.
- (9) Remove the retainer ring (14) that holds the stop-start lever (15) to the pivot stud on the frame; remove the stop-start lever.
- (10) Remove the retainer rings (16 and 17) from the pin (18); remove the pin from the lower switch bail lever (19) and from the tape transmitter frame. Remove the lower switch bail lever (19).
- (11) Remove the stop-start lever detent spring (20) from the stop-start lever detent (22) and from the spring post on the tape transmitter frame.
- (12) Remove the retainer ring (21) and

the stop-start lever detent (22) from the pivot post.

b. Reassembly.

- (1) Reassemble the tape transmitter operating levers as indicated in figure 54; the sequence for assembling the parts is the reverse of the disassembly sequence.
- (2) Replace the tape transmitter covers as described in paragraph 94b.
- (3) Replace the tape transmitter as described in paragraph 93b.

97. Disassembly and Reassembly of Code Sensing Levers
(fig. 55)

a. Disassembly.

- (1) Remove the tape transmitter from the

base frame as described in paragraph 93a.

- (2) Remove the tape transmitter covers as described in paragraph 94a.
- (3) Remove the five code sensing lever springs (1) from the code sensing levers (16, 17, 18, 20, and 21) and from the code sensing lever spring post (5).
- (4) Remove the tape feed retracting lever spring (2) from the tape feed retracting lever (14) and from the code sensing lever spring post (5).
- (5) Remove the plain hexagonal nuts (3 and 4) from the code sensing lever spring post (5); remove the code sensing lever spring post from the selector lever comb.

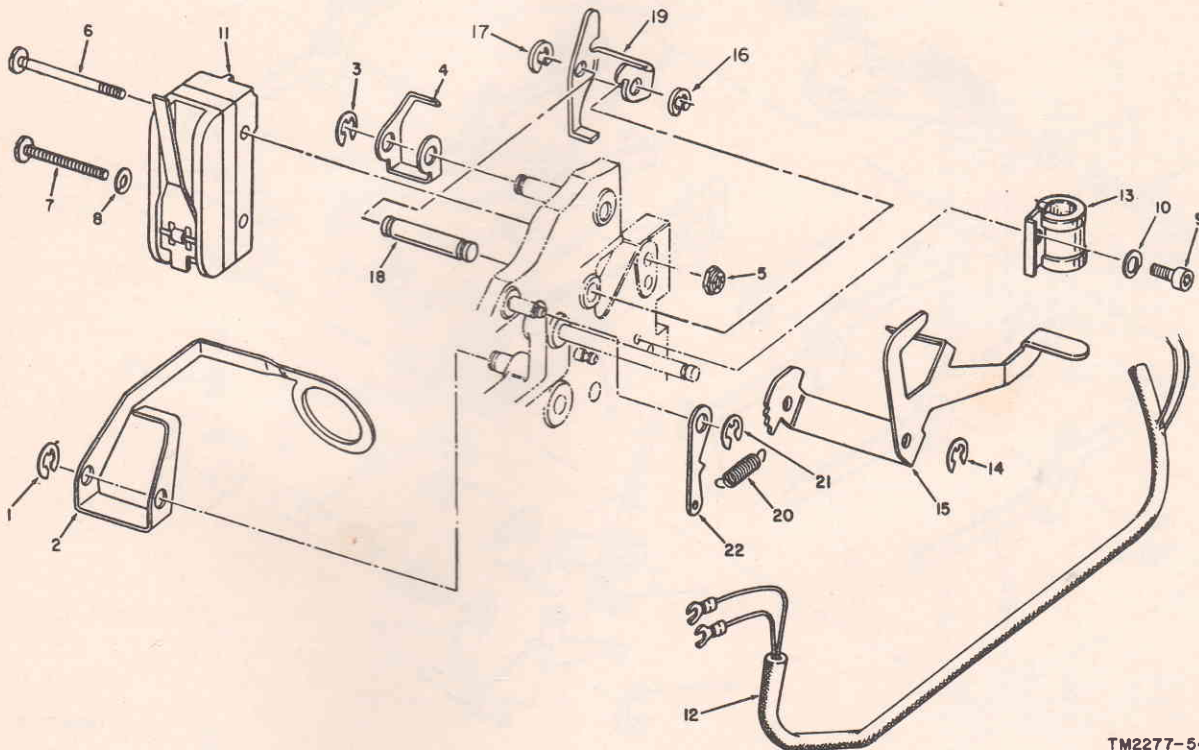

TM2277-54

- | | |
|-------------------------------------|--|
| 1 Retainer ring, 10949 | 12 Wiring harness, 53339 |
| 2 Tight-tape lever, 59705 | 13 Cable clamp, 20507 |
| 3 Retainer ring, 10949 | 14 Retainer ring, 10949 |
| 4 Upper switch bail lever, 52811 | 15 Stop-start lever, 52863 |
| 5 Self-locking hexagonal nut, 10500 | 16 Retainer ring, 10949 |
| 6 Machine screw, 10385 | 17 Retainer ring, 10949 |
| 7 Machine screw, 10359 | 18 Pin, 52872 |
| 8 Lockwasher, 10429 | 19 Lower switch bail lever, 52812 |
| 9 Machine screw, 10003 | 20 Stop-start lever detent spring, 53149 |
| 10 Lockwasher, 10429 | 21 Retainer ring, 10949 |
| 11 Stop-start switch S1, 20108 | 22 Stop-start lever detent, 57206 |

Figure 54. Tape transmitter operating levers, exploded view.

- (6) Remove the tape feed claw spring (6) from the tape feed claw (19) and from the selector lever comb.
- (7) Remove the set screw (7) that holds the code sensing lever stud (13) in the frame.
- (8) Remove the retainer rings (8, 9, 10, 11, and 12) from the code sensing lever stud (13); slide the code sensing lever stud out of the code sensing levers and the frame.
- (9) Remove the tape feed retracting lever (14), sensing lever restoring bail (15), code sensing levers (16, 17, 18,

20, and 21) and the tape feed claw (19) from the selector lever comb.

b. Reassembly.

- (1) Reassemble the tape transmitter selector levers as indicated in figure 55; the sequence for assembling the parts is the reverse of the disassembly sequence.
- (2) Adjust the tape transmitter as described in paragraphs 45 and 54.
- (3) Replace the tape transmitter covers as described in paragraph 94b.
- (4) Replace the tape transmitter as described in paragraph 93b.

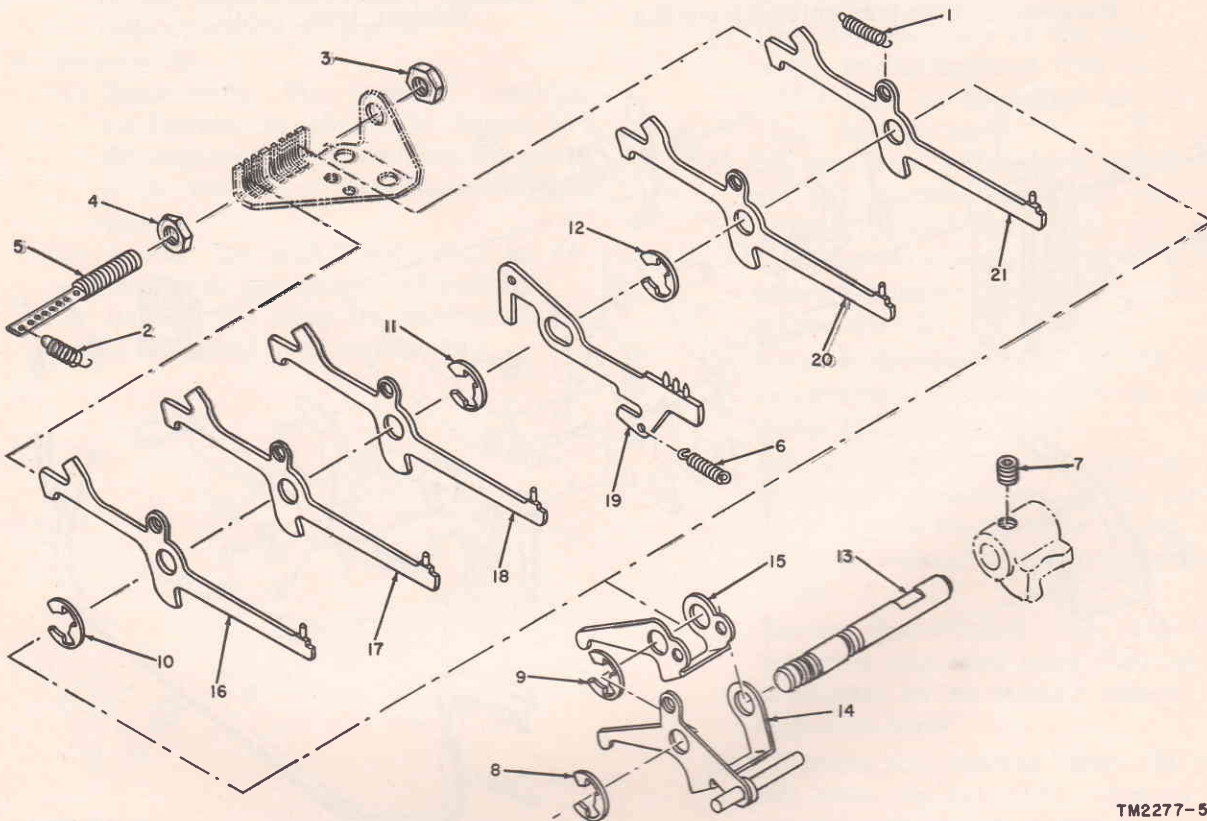

TM2277-55

- | | |
|--|--|
| 1 Code sensing lever spring, 53152 | 11 Retainer ring, 10957 |
| 2 Tape feed retracting lever spring, 53154 | 12 Retainer ring, 10957 |
| 3 Plain hexagonal nut, 10509 | 13 Code sensing lever stud, 52835 |
| 4 Plain hexagonal nut, 10509 | 14 Tape feed retracting lever, 52829A |
| 5 Code sensing lever spring post, 50325 | 15 Sensing lever restoring bail, 52858 |
| 6 Tape feed claw spring, 53153 | 16 Code sensing lever, 52844 |
| 7 Set screw, 10209 | 17 Code sensing lever, 52844 |
| 8 Retainer ring, 10957 | 18 Code sensing lever, 52844 |
| 9 Retainer ring, 10957 | 19 Tape feed claw, 52836 |
| 10 Retainer ring, 10957 | 20 Code sensing lever, 52844 |
| | 21 Code sensing lever, 52844 |

Figure 55. Code sensing levers, exploded view.

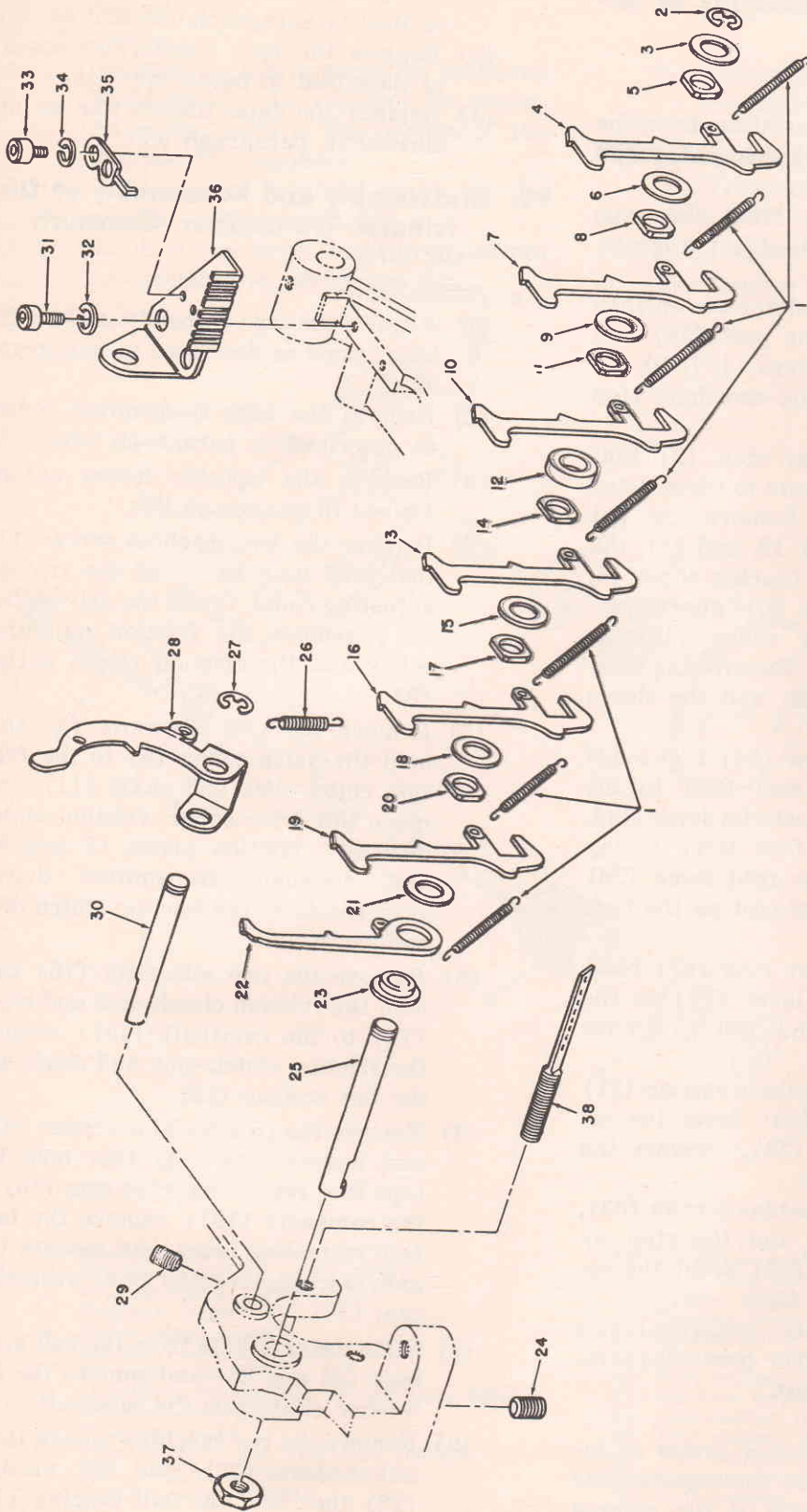

- 1 Selector lever spring, 50902
- 2 Retainer ring, 10949
- 3 Flat washer, 50147
- 4 Selector lever, 51598A
- 5 Bearing shoe, 51644A
- 6 Flat washer, 50147
- 7 Selector lever, 51598A
- 8 Bearing shoe, 51644A
- 9 Flat washer, 50147
- 10 Selector lever, 51598A
- 11 Bearing shoe, 51644A
- 12 Spacer collar, 52833
- 13 Selector lever, 51598A

- 14 Bearing shoe, 51644A
- 15 Flat washer, 50147
- 16 Selector lever, 51598A
- 17 Bearing shoe, 51644A
- 18 Flat washer, 50147
- 19 Selector lever, 51598A
- 20 Bearing shoe, 51644A
- 21 Flat washer, 50147
- 22 Camshaft stop lever, 53613
- 23 Sleeve bearing, 52824
- 24 Set screw, 10210
- 25 Selector lever stud, 52840

- 26 Tape feed lever spring, 53151
- 27 Retainer ring, 10949
- 28 Tape feed lever, 52845
- 29 Set screw, 10210
- 30 Tape feed lever stud, 52842
- 31 Machine screw, 10003
- 32 Lockwasher, 10429
- 33 Machine screw, 10002
- 34 Lockwasher, 10429
- 35 Stop selector lever latch, 55870
- 36 Selector lever comb, 52841
- 37 Plain hexagonal nut, 10509
- 38 Anchor post, 50325

TM2277-56

Figure 56: Selector levers, exploded view.

98. Disassembly and Reassembly of Selector Levers

(fig. 56)

a. Disassembly.

- (1) Remove the tape transmitter from the base frame as described in paragraph 93a.
- (2) Remove the covers from the tape transmitter as described in paragraph 94a.
- (3) Remove the six selector lever springs (1) from the anchor post (38) and from the selector levers (4, 7, 10, 13, 16, and 19), and the camshaft stop lever (22).
- (4) Remove the retainer ring (2) that holds the selector levers to the selector lever stud (25). Remove the flat washers (3, 6, 9, 15, 18, and 21), the selector levers, and bearing shoes (5, 8, 11, 14, 17, and 20) alternately. Remove the spacer collar (12) as shown in sequence. Remove the camshaft stop lever (22) and the sleeve bearing (23).
- (5) Remove the setscrew (24) that holds the selector lever stud (25) in the frame; remove the selector lever stud.
- (6) Remove the tape feed lever spring (26) from the tape feed lever (28) and from the spring post on the tape transmitter frame.
- (7) Remove the retainer ring (27) holding the tape feed lever (28) to the tape feed lever stud (30); remove the tape feed lever.
- (8) Remove the two machine screws (31) and lockwashers (32) from the selector lever comb (36); remove the selector lever comb.
- (9) Remove the two machine screws (33), lockwashers (34), and the stop selector lever latch (35) from the selector lever comb (36).
- (10) Remove the plain hexagonal nut (37) from the anchor post (38); remove the anchor post.

b. Reassembly.

- (1) Reassemble the selector levers as indicated in figure 56; the sequence for assembling the parts is the reverse of the disassembly sequence.

- (2) Adjust the tape transmitter as described in paragraphs 45 and 54.
- (3) Replace the tape transmitter covers as described in paragraph 94b.
- (4) Replace the tape transmitter as described in paragraph 93b.

99. Disassembly and Reassembly of Distributor-Transmitter Camshaft

(fig. 57)

a. Disassembly.

- (1) Remove the tape transmitter from the base frame as described in paragraph 93a.
- (2) Remove the tape transmitter covers as described in paragraph 94a.
- (3) Remove the selector levers as described in paragraph 98a.
- (4) Remove the two machine screws (1) that hold both halves of the friction adjusting collar (2) to the drive collar (5); remove the friction adjusting collar and the friction clutch spring (3).
- (5) Remove the two setscrews (4) that hold the drive collar (5) to the friction clutch disk and shaft (11); remove the drive collar, friction clutch disk (6), friction plates (7 and 9), and distributor-transmitter driven gear (8) from the friction clutch disk and shaft.
- (6) Remove the two setscrews (10) that hold the friction clutch disk and shaft (11) to the camshaft (19); remove the friction clutch disk and shaft and the flat washer (12).
- (7) Remove the two machine screws (13) and lockwashers (14) that hold the tape feed retracting lever cam (15) to the camshaft (19); remove the tape feed retracting lever cam, spacers (16 and 18), and sensing lever restoring cam (17).
- (8) Slide the camshaft from the ball bearings (24 and 26) and remove the flat washer (20) from the camshaft.
- (9) Remove the two machine screws (21), lockwashers (22), and flat washers (23) that hold the ball bearing (24) in place; remove the ball bearing

(24), spacing collar (25), and ball bearing (26).

b. Reassembly.

- (1) Reassemble the camshaft as indicated in figure 57; the sequence for assembling the parts is the reverse of the disassembly sequence.
- (2) Replace the selector levers as described in paragraph 98b.
- (3) Replace the tape transmitter covers as described in paragraph 94b.

- (4) Replace the tape transmitter on the base frame as described in paragraph 93b.
- (5) Adjust the friction clutch as described in paragraph 57.

100. Disassembly and Reassembly of Transmitter Contacts
(fig. 58)

a. Disassembly.

- (1) Remove the tape transmitter from the

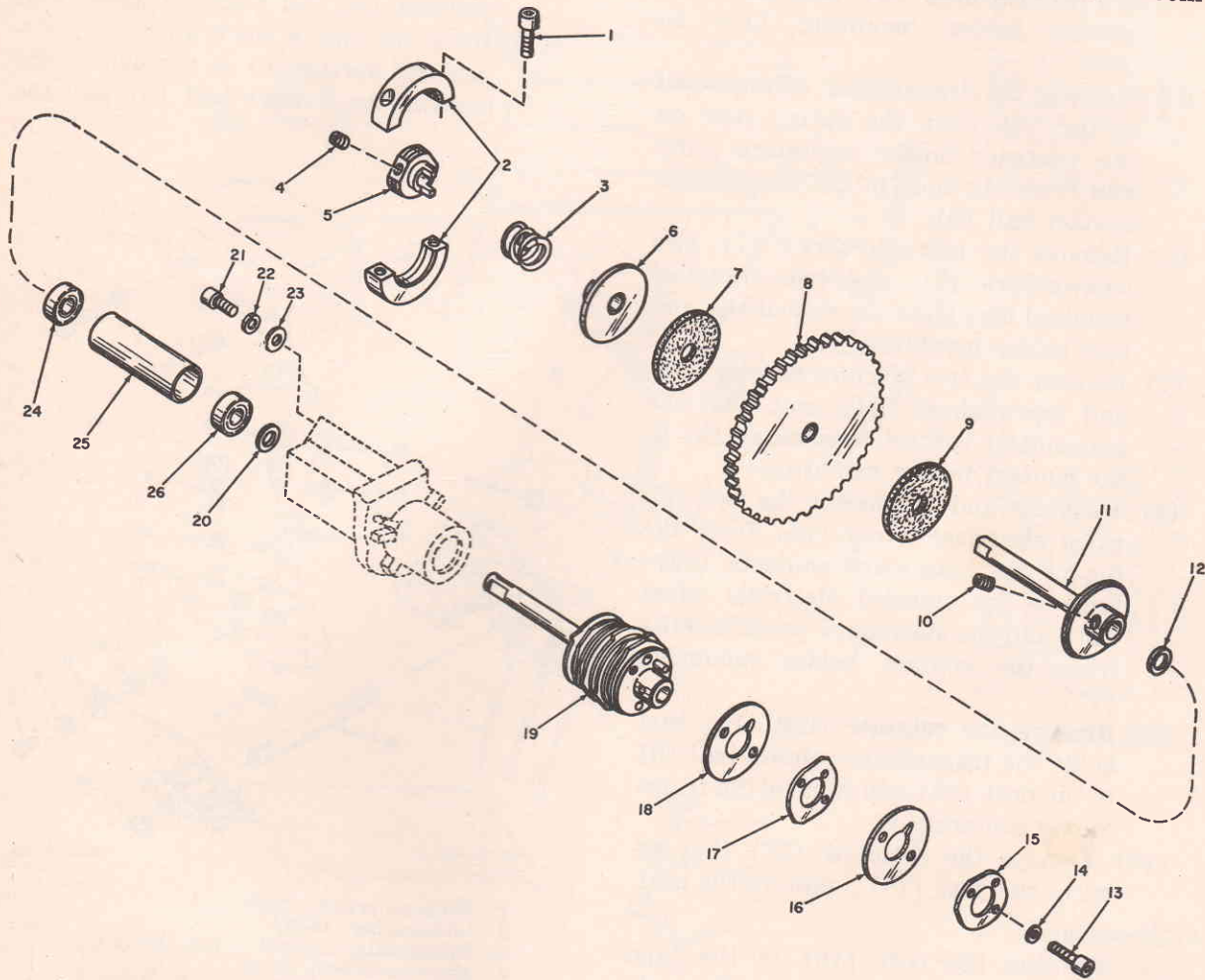

- | | | | |
|----|--|----|---------------------------------------|
| 1 | Machine screw, 10034 | 14 | Lockwasher, 10429 |
| 2 | Friction adjusting collar, 56381 | 15 | Tape feed retracting lever cam, 52867 |
| 3 | Friction clutch spring, 54934 | 16 | Spacer, 56175 |
| 4 | Setscrew, 10208 | 17 | Sensing lever restoring cam, 52868 |
| 5 | Drive collar, 54928 | 18 | Spacer, 56175 |
| 6 | Friction clutch disk, 54931 | 19 | Camshaft, 52871 |
| 7 | Friction plate, 56765 | 20 | Flat washer, 52210 |
| 8 | Distributor-transmitter driven gear, 58283 | 21 | Machine screw, 10004 |
| 9 | Friction plate, 56765 | 22 | Lockwasher, 10429 |
| 10 | Setscrew, 10208 | 23 | Flat washer, 10450 |
| 11 | Friction clutch disk and shaft, 58282A | 24 | Ball bearing, 10753 |
| 12 | Flat washer, 51552 | 25 | Spacing collar, 52852 |
| 13 | Machine screw, 10004 | 26 | Ball bearing, 10753 |

TM2277-57

Figure 57. Distributor-transmitter camshaft, exploded view.

base frame as described in paragraph 93a.

- (2) Remove the tape transmitter covers as described in paragraph 94a.
- (3) Remove the two machine screws (1) and four lockwashers (2) that hold the transmitter contact cover (3) to the tape transmitter frame; remove the transmitter contact cover.
- (4) Remove the two machine screws (4) and lockwashers (5) that hold the contact holder mounting (15) in place.
- (5) Unhook the transmitter contact bail spring (6) from the spring post on the contact holder mounting (15) and from the hole in the transmitter contact bail (9).
- (6) Remove the machine screw (7), two lockwashers (8), and two electrical terminal lugs from the side of the contact holder mounting.
- (7) Remove the two machine screws (10) and lockwashers (11) that hold the transmitter contact terminals (12) to the contact holder mounting.
- (8) Unsolder and disconnect the two spiraled electrical wires (14) from the top of the stationary contacts (13); remove the spiraled electrical wires (14) and the stationary contacts (13) from the contact holder mounting (15).
- (9) Remove the retainer ring (16) that holds the transmitter contact bail (9) to the post (18) and remove the transmitter contact bail.
- (10) Remove the setscrew (17) that secures the post (18); remove the post.

b. Reassembly.

- (1) Position the post (18) in the tape transmitter frame; secure with a setscrew (17).
- (2) Position the transmitter contact bail (9) on the post (18); secure with a retainer ring (16).
- (3) Install the two stationary contacts (13) in the contact holder mounting (15).
- (4) Solder the electrical wires (14) in the slots in the top of the stationary contacts (13).

- (5) Insert the transmitter contact terminals (12) in the threads of the stationary contacts (13), $\frac{1}{2}$ to $1\frac{1}{2}$ threads above the contact holder mounting (15); hold the contacts in place with the lockwashers (11) and machine screws (10) but do not tighten the screws.
- (6) Position the two electrical terminal lugs on the side of the contact holder mounting (15); secure with the lockwashers (8) and machine screw (7).
- (7) Hook one end of the transmitter contact bail spring (6) in the hole in the transmitter contact bail (9) and the

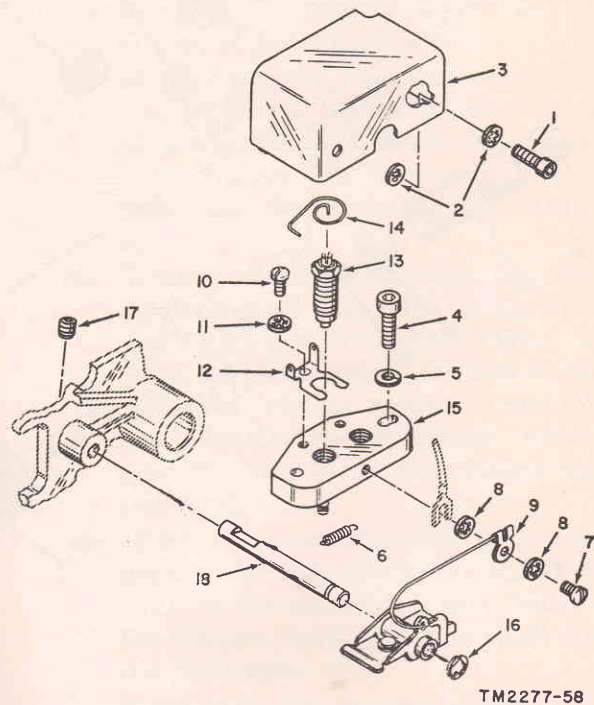

- 1 Machine screw, 10005
- 2 Lockwasher, 10403
- 3 Transmitter contact cover, 52898A
- 4 Machine screw, 10009
- 5 Lockwasher, 10430
- 6 Transmitter contact bail spring, 51548
- 7 Machine screw, 10301
- 8 Lockwasher, 10403
- 9 Transmitter contact bail, 51582A
- 10 Machine screw, 10301
- 11 Lockwasher, 10403
- 12 Transmitter contact terminal, 51597
- 13 Stationary contact, 51588A
- 14 Electrical wire, 51610
- 15 Contact holder mounting, 51595A
- 16 Retainer ring, 10949
- 17 Setscrew, 10209
- 18 Post, 52839

Figure 58. Transmitter contacts, exploded view.

other end on the spring post on the contact holder mounting.

- (8) Position the contact holder mounting (15) so that the contacts are in correct alignment with the contacts of the transmitter contact bail; secure with the two lockwashers (5) and machine screws (4).
- (9) Position the transmitter contact cover (3) over the contact holder mounting; secure with the two lockwashers (2) and machine screws (1).
- (10) Adjust the transmitter contacts as described in paragraphs 43 and 44.
- (11) Replace the tape transmitter covers as described in paragraph 94b.
- (12) Replace the tape transmitter as described in paragraph 93b.

101. Disassembly and Reassembly of Clutch Magnet L1, Filter FL1, and Terminal Board TB1

(fig. 59)

a. Disassembly.

- (1) Remove the tape transmitter from the base frame as described in paragraph 93a.
- (2) Remove the tape transmitter covers as described in paragraph 94a.
- (3) Disconnect all leads from terminal board TB1 (10); tag the leads.
- (4) Unsolder and disconnect the electrical leads (1, 2, and 3) from filter FL1 (14); tag the leads.
- (5) Remove the plain hexagonal nut (4), lockwasher (5), and machine screw (6) that hold the cable clamp (7) to the terminal board mounting bracket (21); remove the cable clamp.
- (6) Remove the four machine screws (8) and lockwashers (9) that hold terminal board TB1 (10) and terminal marker strip (11) to the terminal board mounting bracket (21); remove the terminal board and terminal markerstrip.
- (7) Remove the four machine screws (12) and lockwashers (13) that attach filter FL1 (14) to the filter mounting bracket (20); remove filter FL1.
- (8) Remove the machine screw (15) and lockwasher (16) that hold the ground-

ing lead (17); remove the grounding lead.

- (9) Remove the four machine screws (18) and lockwashers (19) that hold the filter mounting bracket (20) and the terminal board mounting bracket (21) to the tape transmitter frame; remove the filter mounting bracket and the terminal board mounting bracket.
- (10) Remove the two machine screws (22), lockwashers (23), and flat washers (24) that hold clutch magnet L1 (25) to the tape transmitter frame; remove the clutch magnet L1.
- (11) Remove the clutch magnet armature spring (26) from the clutch magnet armature (28) and from the spring post on the tape transmitter frame.
- (12) Remove the retainer ring (27) that holds the clutch magnet armature (28) to the pivot stud and remove the clutch magnet armature.
- (13) Remove the setscrew (29) that holds the eccentric stud (30) in the tape transmitter frame; remove the eccentric stud.

b. Reassembly.

- (1) Reassemble the tape transmitter as indicated in figure 59; the sequence for assembling the parts is the reverse of the disassembly sequence. Connect the electrical leads as indicated in figures 47 and 48.
- (2) Replace the tape transmitter covers as described in paragraph 94b.
- (3) Replace the tape transmitter on the base frame as described in paragraph 93b.

102. Disassembly and Reassembly of Tape Transmitter Frame

(fig. 60)

a. Disassembly.

- (1) Remove the tape transmitter from the base frame as described in paragraph 93a.
- (2) Remove the tape transmitter covers as described in paragraph 94a.
- (3) Remove the tape transmitter mechanisms as described in paragraphs 95 through 101.

- (4) Remove the two cover mounting posts (3) from the distributor-transmitter frame.
- (5) Remove any loose or damaged spring post or pivot post from the distributor-transmitter frame. Support the frame near the post to be removed to prevent distortion to the frame.

b. Reassembly.

- (1) Replace any spring post or pivot post that has been removed by pressing it into the tape transmitter frame at a right angle to the plane of the frame.
- (2) Install the two cover mounting posts (3) in the tape transmitter frame.
- (3) Replace the tape-transmitter mechanisms as described in paragraphs 95 through 101.

- (4) Replace the tape transmitter covers as described in paragraph 94b.
- (5) Replace the tape transmitter on the base frame as described in paragraph 93b.
- (6) Adjust the tape transmitter as described in paragraphs 40 through 57.

103. Disassembly and Reassembly of Base Electrical Components (TT-122A/FG)

(fig. 61)

a. Disassembly.

- (1) Invert the distributor-transmitter unit so that it rests on the tape transmitter top cover and the top of the motor dust cover.
- (2) Remove the four machine screws (1),

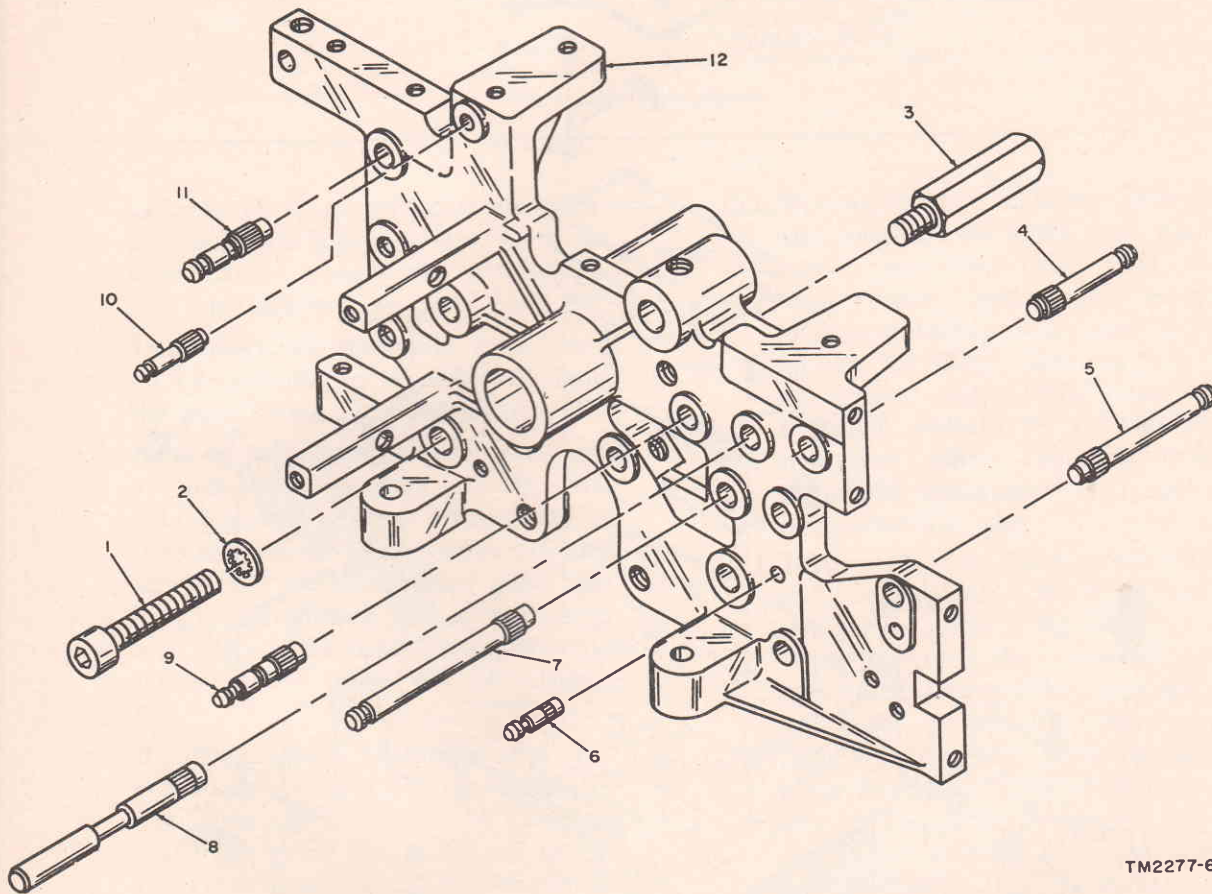

TM2277-60

- | | |
|---------------------------------|----------------------------------|
| 1 Machine screw, 10030 | 7 Stop-start lever stud, 52854 |
| 2 Lockwasher, 10405 | 8 Stop post, 52856 |
| 3 Post, 52851 | 9 Detent lever stud, 52855 |
| 4 Upper switch bail post, 52873 | 10 Spring post, 50455 |
| 5 Tight-tape stud, 52857 | 11 Armature pivot stud, 52837 |
| 6 Spring post, 51123 | 12 Tape transmitter frame, 52674 |

Figure 60. Tape transmitter frame, exploded view.

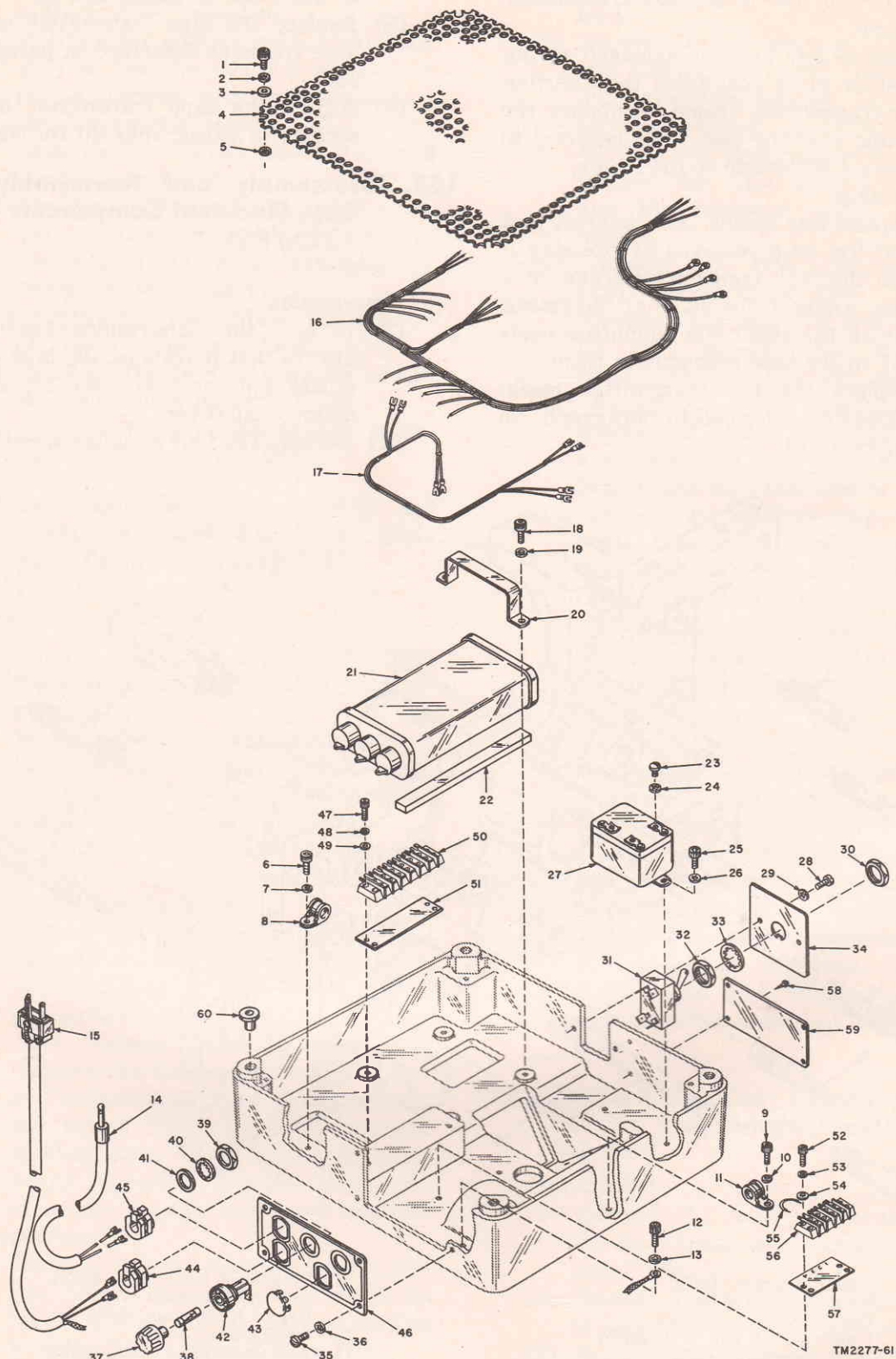
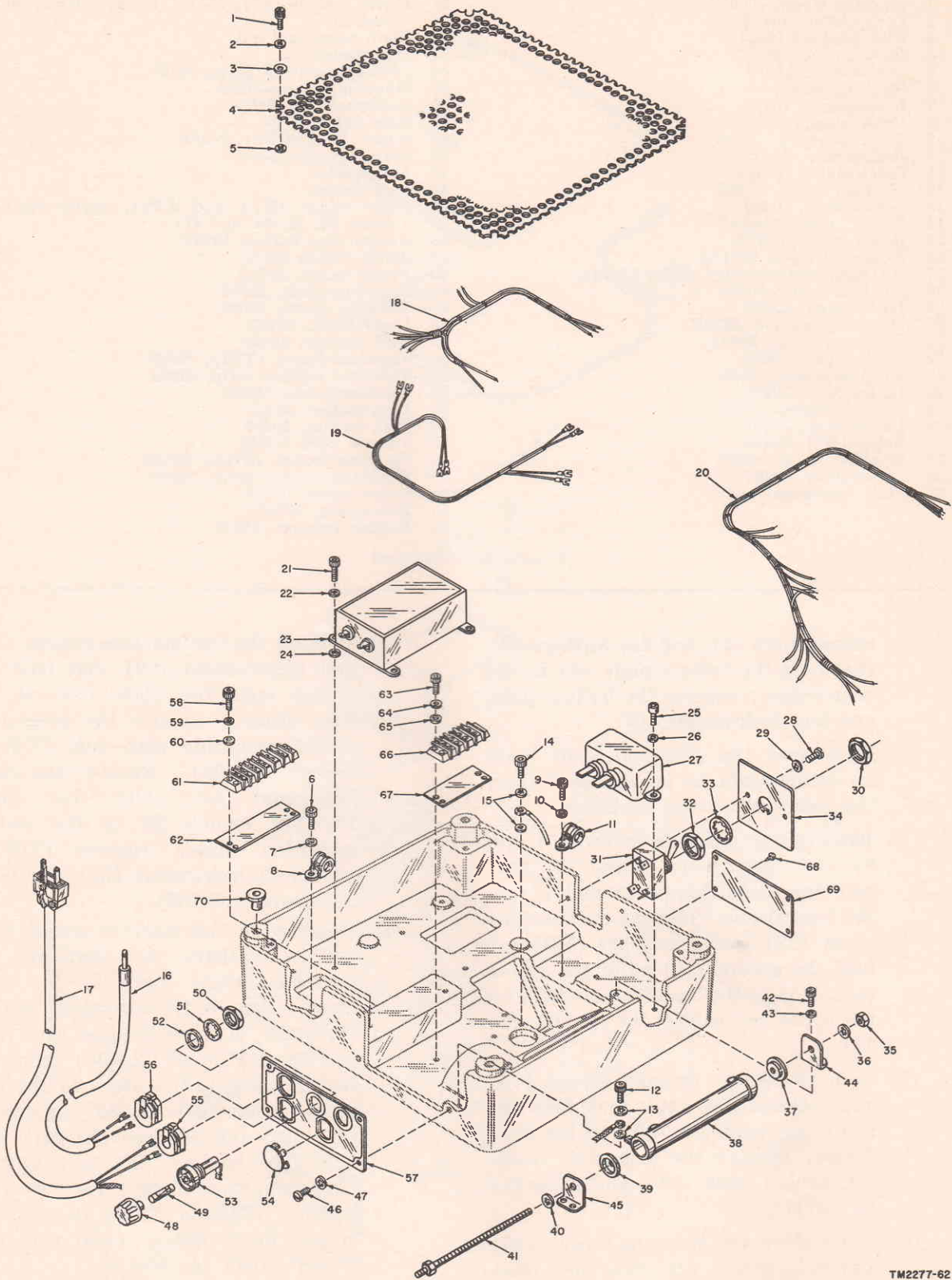

Figure 61. Base electrical components (TT-122A/FG), exploded view.

1	Machine screw, 10055	31	Power switch (S3), 20115 (includes items 30, 32, and 33)
2	Lockwasher, 10403	32	Plain hexagonal nut
3	Flat washer, 10454	33	Lockwasher
4	Bottom plate, 59681	34	Switch mounting plate, 59706
5	Lockwasher, 10403	35	Machine screw, 10393
6	Machine screw, 10003	36	Lockwasher, 10403
7	Lockwasher, 10429	37	Fuse cap
8	Cable clamp, 20538	38	Fuse (F1 and F2), 20468
9	Machine screw, 10003	39	Plain hexagonal nut
10	Lockwasher, 10429	40	Lockwasher
11	Cable clamp, 20519	41	Flat washer
12	Machine screw, 10055	42	Fuse holder (XF1 and XF2), 20458 (includes items 37, 39, 40, and 41)
13	Lockwasher, 10403	43	Access plug button, 59792
14	Signal cord, 57242A	44	Strain relief, 20713
15	Power cord, 59687A	45	Strain relief, 20713
16	Ac power cable, 59717A	46	Mounting plate, 59682
17	Distributor-transmitter cable, 59694A	47	Machine screw, 10006
18	Machine screw, 10003	48	Lockwasher, 10421
19	Lockwasher, 10429	49	Flat washer, 10459
20	Mounting bracket, 54206	50	Terminal board (TB2), 21040
21	Capacitor (C1), 53344	51	Terminal marker strip, 21041
22	Rubber pad, 59824	52	Machine screw, 10006
23	Machine screw, 10003	53	Lockwasher, 10421
24	Lockwasher, 10429	54	Flat washer, 10459
25	Machine screw, 10354	55	Jumper wire, 20642
26	Lockwasher, 10403	56	Terminal board (TB3), 20368
27	Relay (K1), 20120	57	Terminal marker strip, 20388
28	Machine screw, 10393	58	Drive screw, 10336
29	Lockwasher, 10403	59	Nameplate, 59702
30	Plain hexagonal nut	60	Rubber bumper, 11073

Figure 61—Continued

- lockwashers (2), and flat washers (3) that hold the bottom plate (4) to the base frame; remove the bottom plate and four lockwashers (5).
- (3) Disconnect the electrical leads from all components to be removed from the base frame; tag the leads.
- (4) Remove the machine screws (6 and 9), and lockwashers (7 and 10), that hold the cable clamps (8 and 11) to the base frame. Remove the machine screw (12) and lockwasher (13) that hold the grounding lead of the power cord (15) to the base frame. Remove the cords and cables (14, 15, 16, and 17).
- (5) Remove the four machine screws (18) and lockwashers (19) that hold the mounting brackets (20) to the base frame; remove the mounting brackets, rubber pads (22), and capacitor C1 (21).
- (6) Remove the two machine screws (25) and lockwashers (26) that hold relay K1 (27) to the base frame; remove relay K1.
- (7) Remove the two machine screws (28) and lockwashers (29) that hold the switch mounting plate (34) to the base frame; remove the assembled switch mounting plate and POWER switch S3 (31). Remove the plain hexagonal nut (30) that holds POWER switch S3 to the switch mounting plate; remove POWER switch S3, lockwasher (33), and plain hexagonal nut (32).
- (8) Remove the four machine screws (35) and lockwashers (36) that hold the mounting plate (46) to the base frame; remove the assembled mounting plate. Remove the fuse caps (37) and fuses F1 and F2 (38) from the fuse holders (42). Remove the two plain hexagonal nuts (39), lockwashers (40), and flat washers (41) that hold fuse holders XF1 and XF2 to the mounting plate; remove fuse holders XF1 and XF2. Remove the access plug button (43) and two strain reliefs (44 and 45).
- (9) Remove the machine screws (47 and 52), lockwashers (48 and 53), and



TM2277-62

Figure 62. Base electrical components (TT-123A/FG), exploded view.

1	Machine screw, 10055	36	Lockwasher, 10404
2	Lockwasher, 10403	37	Centering washer, 10456
3	Flat washer, 10454	38	Resistor (R1), 51628
4	Bottom plate, 59681	39	Centering washer, 10456
5	Lockwasher, 10403	40	Lockwasher, 10404
6	Machine screw, 10003	41	Stud, 56220A
7	Lockwasher, 10429	42	Machine screw, 10003
8	Cable clamp, 20538	43	Lockwasher, 10429
9	Machine screw, 10003	44	Bracket, 59783
10	Lockwasher, 10429	45	Bracket, 59783
11	Cable clamp, 20519	46	Machine screw, 10393
12	Machine screw, 10055	47	Lockwasher, 10403
13	Lockwasher, 10403	48	Fuse cap
14	Machine screw, 10055	49	Fuse (F1 and F2), 20455
15	Lockwasher, 10403	50	Plain hexagonal nut
16	Signal cord, 57242A	51	Lockwasher
17	Power cord, 59687A	52	Flat washer
18	Ac power cable, 59718A	53	Fuse holder (XF1 and XF2), 20458 (includes items 48, 50, 51, and 52)
19	Distributor-transmitter cable, 59694A	54	Access plug button, 59792
20	Motor filter cable, 59719A	55	Strain relief, 20713
21	Machine screw, 10055	56	Strain relief, 20713
22	Lockwasher, 10403	57	Mounting plate, 59683
23	Filter (FL2), 54581	58	Machine screw, 10006
24	Lockwasher, 10403	59	Lockwasher, 10421
25	Machine screw, 10003	60	Flat washer, 10459
26	Lockwasher, 10429	61	Terminal board (TB2), 21040
27	Capacitor, 20214	62	Terminal marker strip, 21041
28	Machine screw, 10393	63	Machine screw, 10006
29	Lockwasher, 10403	64	Lockwasher, 10421
30	Plain hexagonal nut	65	Flat washer, 10459
31	POWER switch (S3), 20115 (includes items 30, 32, and 33)	66	Terminal board (TB3), 20368
32	Plain hexagonal nut	67	Terminal marker strip, 20388
33	Lockwasher	68	Drive screw, 10336
34	Switch mounting plate, 59706	69	Nameplate, 59703
35	Plain hexagonal nut, 10516	70	Rubber bumper, 11073

Figure 62—Continued

flat washers (49 and 54) that hold the terminal boards (50 and 56) to the base frame; remove the terminal boards, jumper wire (55) and terminal marker strips (51 and 57).

(10) Remove the four drivescrews (58) that hold the nameplate (59) to the base frame; remove the nameplate.

(11) Remove the four rubber bumpers (60).

b. Reassembly. Reassemble the base frame electrical components as shown in figure 61; the sequence for assembling the parts is the reverse of the disassembly sequence.

104. Disassembly and Reassembly of Base Electrical Components (TT-123A/FG)

(fig. 62)

a. Disassembly.

(1) Invert the distributor-transmitter unit so that it rests on the tape transmitter top cover and the top of the motor dust cover.

(2) Remove the four machine screws (1), lockwashers (2), and flat washers (3) that hold the bottom plate (4) to the base frame; remove the bottom plate and four lockwashers (5).

(3) Disconnect the electrical leads from all components to be removed from the base frame; tag the leads.

(4) Remove the machine screws (6 and 9) and lockwashers (7 and 10) that hold the cable clamps (8 and 11) to the base frame. Remove the machine screws (12 and 14) and lockwashers (13 and 15) that hold the grounding leads to the base frame. Remove the cords and cables (16, 17, 18, 19, and 20).

(5) Remove the four machine screws (21) and lockwashers (22) that hold filter FL2 (23) to the base frame; remove filter FL2.

(6) Remove the two machine screws (25) and lockwashers (26) that hold the capacitor (27) to the base frame; remove the capacitor.

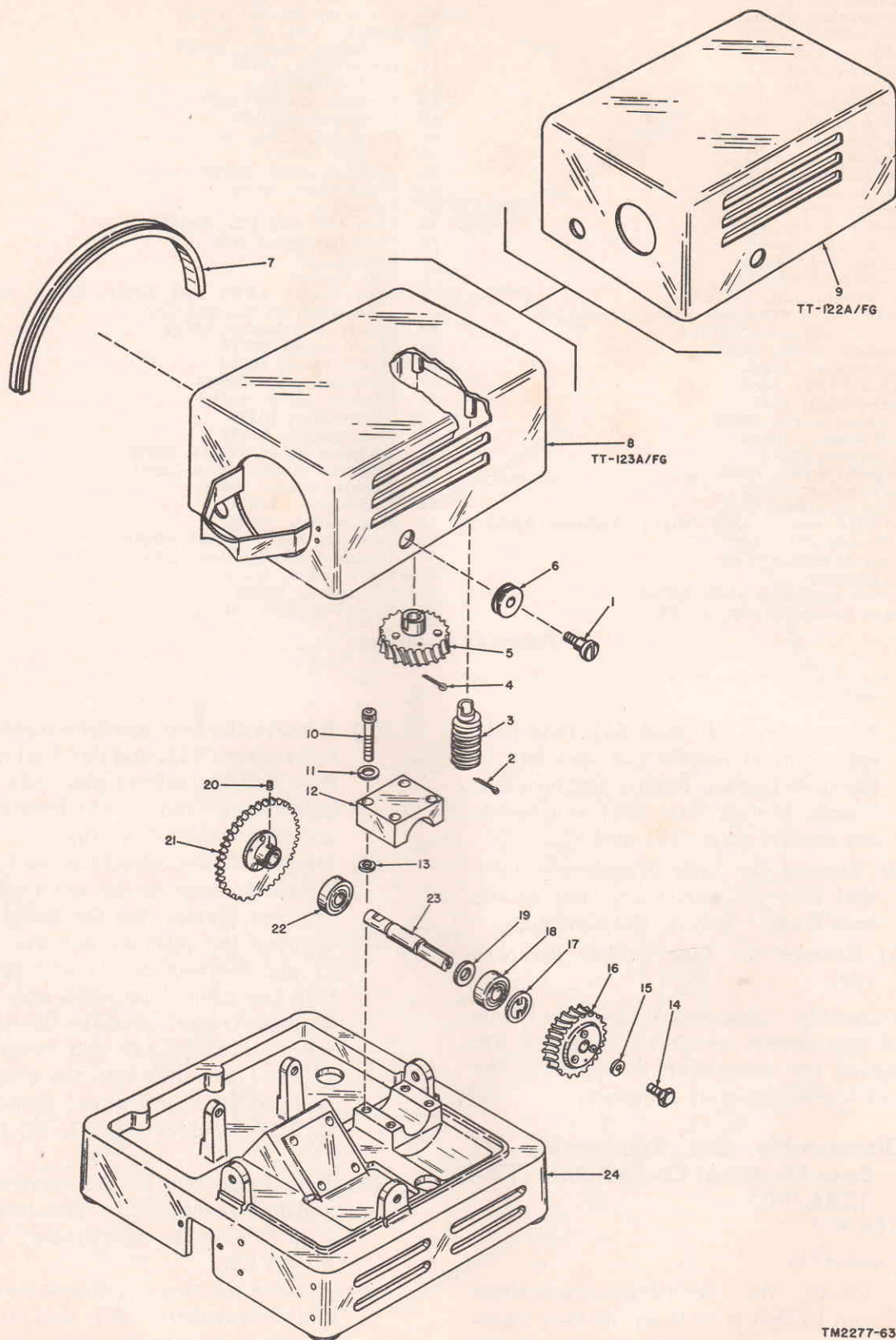

Figure 63. Motor dust cover, base frame, and power shaft, exploded view.

- | | | | |
|----|---------------------------------------|----|--|
| 1 | Shoulder screw, 52701 | 13 | .003-in. shim, 57073 |
| 2 | Cotter pin, 10805 | 14 | Machine screw, 56124 |
| 3 | Alternate worm gear, 52108 | 15 | Lockwasher, 10438 |
| 4 | Cotter pin, 10805 | 16 | Motor-driven gear, 52106A |
| 5 | Alternate motor-driven gear, 52109A | 17 | Gear key, 54566 |
| 6 | Grommet, 59713 | 18 | Ball bearing, 10758 |
| 7 | Rubber bumper, 59709 | 19 | Flat washer, 50746 |
| 8 | Motor dust cover (TT-123A/FG), 59708A | 20 | Setscrew, 10209 |
| 9 | Motor dust cover (TT-122A/FG), 59707 | 21 | Distributor-transmitter driving gear, 59701A |
| 10 | Machine screw, 10030 | 22 | Ball bearing, 10758 |
| 11 | Lockwasher, 10431 | 23 | Power shaft, 59684 |
| 12 | Bearing block, 59691A | 24 | Base frame, 59693A (TT-122A/FG); 59715A (TT-123A/FG) |

Figure 63—Continued

- (7) Remove the two machine screws (28) and lockwashers (29) that hold the switch mounting plate (34) to the base frame; remove the assembled switch mounting plate. Remove the plain hexagonal nut (30) that holds POWER switch S3 (31) to the switch mounting plate; remove POWER switch S3, lockwasher (33), and the plain hexagonal nut (32).
- (8) Remove the plain hexagonal nut (35) and lockwasher (36) that hold the stud (41) to the brackets (44 and 45); remove the stud from the brackets, catching the centering washer (37), resistor R1 (38), centering washer (39), and lockwasher (40) as they are released from the stud. Remove the four machine screws (42) and lockwashers (43) that hold the brackets (44 and 45) to the base frame; remove the brackets.
- (9) Remove the four machine screws (46) and lockwashers (47) that hold the mounting plate (57) to the base frame; remove the assembled mounting plate. Remove the fuse caps (48) and fuses F1 and F2 (49) from the fuse holders. Remove the two plain hexagonal nuts (50), lockwashers (51), and plain washers (52) that hold fuse holders XF1 and XF2 (53) to the mounting plate; remove fuse holders XF1 and XF2. Remove the access plug button (54) and strain reliefs (55 and 56).
- (10) Remove the machine screws (58 and 63), lockwashers (59 and 64), and flat washers (60 and 65) that hold terminal boards TB2 and TB3 (61 and 66) to the base frame; remove the terminal boards and terminal marker strips (62 and 67).
- (11) Remove the four drive screws (68) that hold the nameplate (69) to the base frame; remove the nameplate. Remove the four rubber bumpers (70).
 - b. *Reassembly.* Reassemble the base frame electrical components as indicated in figure 62; the sequence for assembling the parts is the reverse of the disassembly sequence.

105. Disassembly and Reassembly of Motor Dust Cover, Base Frame, and Power Shaft (fig. 63)

a. *Disassembly.*

- (1) Remove the base electrical components as described in paragraph 103a or 104a.
- (2) Remove the motor as described in paragraph 89a.
- (3) Remove the tape transmitter as described in paragraph 93a.
- (4) Remove the cotter pins (2 and 4) that hold the alternate worm gear (3) and motor-driven gear (5) to the studs on the inside of the motor dust cover; remove the alternate worm gear and motor-driven gear.
- (5) Remove the three grommets (6) from the motor dust cover (8 or 9). Remove the rubber bumper (7).
- (6) Remove the four machine screws (10) and lockwashers (11) that hold the bearing block (12) to the base frame; remove the bearing block and four flat washers (13). Remove the assembled power shaft.

- (7) Remove the machine screw (14) and lockwasher (15) that hold the motor-driven gear (16) to the power shaft (23); remove the motor-driven gear.
- (8) Remove the five gear keys (17), ball bearing (18), and flat washer (19) from the power shaft (23).
- (9) Remove the two setscrews (20) that hold the tape transmitter driving gear (21) to the power shaft; remove the driving gear (21) and ball bearing (22).

b. Reassembly.

- (1) Reassemble the motor dust covers, base frame, and power shaft as shown in figure 63; the sequence for assembling the parts is the reverse of the disassembly sequence.
- (2) Replace the tape transmitter as described in paragraph 93b.
- (3) Replace the motor as described in paragraph 89b.
- (4) Replace the base electrical components as described in paragraph 103b or 104b.

Section V. SPRING DATA

106. General

a. This section contains data on the coil springs used in the distributor-transmitter. This information is useful when inspecting or overhauling the equipment to determine which springs must be replaced. It is also useful as a check list when reassembling, adjusting, or troubleshooting, and as a means of identifying springs.

b. The charts in paragraphs 107 through 110 give the dimensional and strength characteristics required for each spring used in the unit. Each type of spring is illustrated in figures 64 through 66. The free length is measured between the inside surfaces of the end hooks. If a spring fails to pass its strength test, it should be replaced.

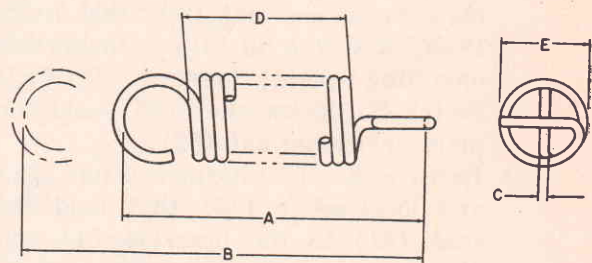

A. CROSSED - END SPRING

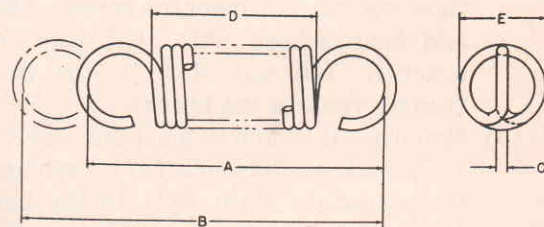

B. PARALLEL - END SPRING

TM2277-64

Figure 64. Cross-end and parallel-end springs.

107. Crossed-End Spring Data (A, fig. 64)

Ref. No.	Name	A Free length (in.)	B Extended length (in.)	Required tension, extended length (oz)	Wire thickness (in.)	D No. of coils	E Diameter (OD) (in.)
53149	Stop-start lever detent	$\frac{25}{32}$	$\frac{7}{8}$	19 to 21	.020 \pm .0003	27	.156
53151	Tape feed lever	$\frac{11}{16}$	$\frac{7}{8}$	34 to 38	.024 \pm .0005	$15\frac{1}{4}$.187
53152	Code sensing lever	$\frac{33}{64}$	$\frac{45}{64}$	11 to 13	.012 \pm .0003	29	.085
53153	Tape feed claw	$\frac{1}{2}$	$\frac{21}{32}$	$2\frac{3}{4}$ to $3\frac{1}{4}$.012 \pm .0003	23	.125
53154	Tape feed retracting lever.	$\frac{15}{32}$	$\frac{3}{4}$	11 to 13	.014 \pm .0003	12	.156
53155	Clutch magnet armature.	$\frac{19}{32}$	$\frac{25}{32}$	4 to 6	.012 \pm .0003	$32\frac{1}{4}$.125

108. Parallel-End Spring Data (B, fig. 64)

Ref. No.	Name	A Free length (in.)	B Extended length (in.)	Required tension, extended length (oz)	Wire C thickness (in.)	D No. of coils	E Diameter (OD) (in.)
50334	Governor adjustment lever.	$15\frac{1}{16}$	1	29 to 35	.026 \pm .0005	26 $\frac{1}{2}$.156
51548	Contact bail	$7\frac{1}{16}$	$9\frac{1}{16}$	10 to 12	.015 \pm .0003	16	$\frac{1}{8}$

109. Compression Spring Data (fig. 65)

Ref. No.	Name	A Free length (in.)	B Compressed length (in.)	Required tension (oz)	Wire C thickness (in.)	D No. of coils	E Diameter (OD) (in.)
54934	Friction clutch	$\frac{3}{8}$	$\frac{5}{16}$	8 lb \pm 12	.080	3 $\frac{1}{2}$.6875 ID
57203	Tape cover latch	$\frac{1}{2}$.281	18 to 22	.013 \pm .0003	20	.086 OD

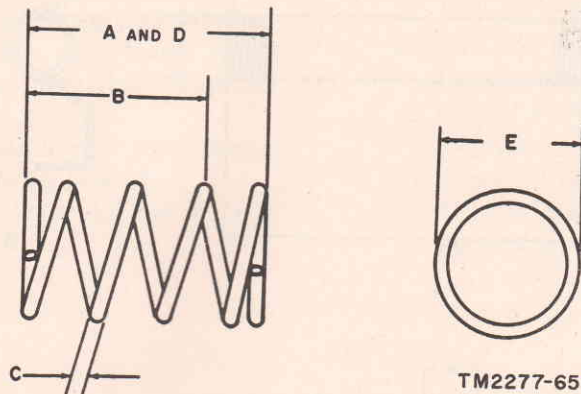

Figure 65. Compression springs.

110. Special Spring Data

Fig. No.	Ref. No.	Name	A Free length (in.)	B Extended length (in.)	Required tension, extended length (oz)	Wire C thickness (in.)	No. of coils	D Diameter (in.)
66A	50902	Selector lever	1	1 $\frac{1}{4}$	7 to 9	.012 \pm .0003	55 max	.085 OD
66B	53156	Tape-out lever	$1\frac{1}{16} \pm \frac{1}{16}$.016 \pm .0003	52	.188 OD
66C	56324	Tape cover	$\frac{5}{32}$.024 \pm .0003	6	$\frac{5}{32}$ ID

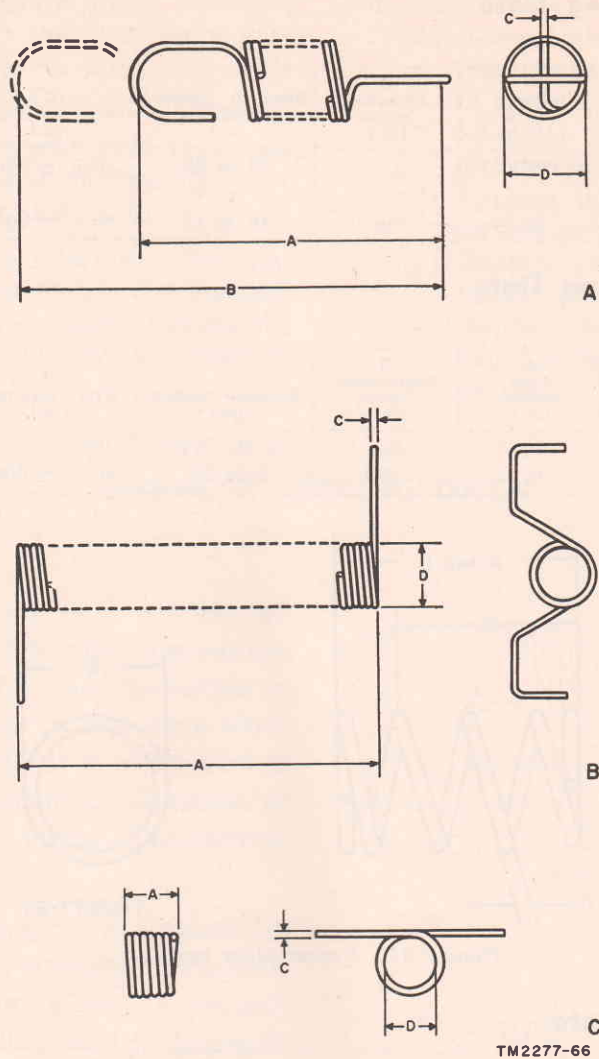

Figure 66. Special springs.

Section VI. FINAL TESTING

111. General

The distributor-transmitter must be tested thoroughly after repair to insure that it meets all performance requirements. Final testing consists of a voltage breakdown test and check of the quality of the transmitted signals.

112. Voltage Breakdown Test

a. Remove the tape transmitter from the base frame as described in paragraph 93*a*. Remove the tape transmitter covers as described in paragraph 94*a*.

b. Connect a ground lead from Ohmmeter ZM-21/U to the frame of the distributor-transmitter. Install the line lead to each of the following points, in turn, and operate the ohmmeter as directed in TM 11-2050A. Check for flashover.

Note. Electrical components and their terminals are coded with the reference number of the component listed first, followed by a dash and the number or symbol of the terminal. For example, P2-1 indicates plug P2, terminal 1, and K1-2 indicates relay K1, terminal 2.

TT-122A/FG	TT-123A/FG
P1-tip	P1-tip
P1-sleeve	P1-sleeve
P2-1	P2-1
P2-2	P2-2
K1-2	TB1-3
TB1-3	

c. Replace the tape transmitter covers as described in paragraph 94*b*. Install the tape transmitter on the base frame as described in paragraph 93*b*.

113. Sending Test Setup

a. Make the necessary ground and power connections as described in paragraph 12.

b. Check the motor speed adjustment (TT-123A/FG) as described in paragraph 14*a*.

c. Check and, if necessary, adjust and lubricate the friction clutch as described in paragraph 57.

d. Connect and check the signal line circuit as described in paragraphs 16 and 17.

e. Move the stop-start lever to the FEED RETRACT position.

114. Sending Tests

a. The distributor-transmitter may be tested by either of two methods. The first method (*b* below) requires the use of Distortion Test Set TS-383*/GG. The second method (par. 19) requires the use of a teletypewriter receiving unit known to be in good operating condition.

b. When Test Set TS-383*/GG is available, proceed as follows:

- (1) Connect the signal line cord of the distributor-transmitter to a line terminating device and connect the stroboscope cord of the TS-383*/GG to the same equipment.
- (2) Plug the ac input plug of the distortion test set into a 115-volt ac source.
- (3) Set the controls of the TS-383*/GG to measure the distortion of transmitted signals as described in TM 11-2217.
- (4) Start the distributor-transmitter (par. 19) and test the quality of transmitted signals as described in TM 11-2217.

CHAPTER 6

SHIPMENT AND LIMITED STORAGE AND DEMOLITION TO PREVENT ENEMY USE

Section I. SHIPMENT AND LIMITED STORAGE

115. Removal from Service

Prepare the distributor-transmitter for storage as follows:

- a. Disconnect the ac power cord from the power source.
- b. Remove the signal cord plug from the line terminating device.
- c. Remove the mounting screws which fasten the distributor-transmitter to the table or shelf.

116. Repacking for Shipment and Limited Storage

- a. If the original packing materials are on hand, use them and reverse the unpacking sequence given in paragraph 9. General repacking information is usually available at depots.
- b. The prime requirement is to pack the equipment to prevent damage during transit or limited storage. Package the equipment securely and use sufficient wadding to lessen the effects of severe jolting.

Section II. DEMOLITION TO PREVENT ENEMY USE

117. Authority for Demolition

To prevent the equipment being used or salvaged by the enemy, it will be completely demolished, but only on the explicit order of the commander. The demolition procedures outlined in paragraph 118 are to be followed carefully.

118. Methods of Destruction

a. *Smash.* Smash the distributor-transmitter, base components, motor, and all other

parts; use sledges, pickaxes, or any suitable heavy tool available.

b. *Cut.* Cut all cords and wiring; use hand-ax or other suitable tool.

c. *Burn.* Burn the technical manuals, cords, and wiring; use gasoline, kerosene, oil, flame thrower, or an incendiary grenade.

d. *Dispose.* Bury or scatter the destroyed parts in slit trenches, foxholes, or throw them into streams.

INDEX

	Paragraphs	Page		Paragraphs	Page
Ac circuits	76	47	Alinement, distributor-transmitter		
Adjustments:			driving gear and driven gear	41	27
Armature eccentric stud, clutch magnet	46	29	Assembly, lubrication, and operational test	83	51
Backlash, distributor-transmitter driving gear and driven gear	42	27	Authority for demolition	117	82
Block, tape cover	53	31	Backlash adjustment, distributor-transmitter driving gear and driven gear	42	27
Clearance:			Base electrical components, disassembly and reassembly:		
Code sensing lever and selector lever	54	32	TT-122A/FG	103	71
Tape cover	52	31	TT-123A/FG	104	75
Clutch magnet armature eccentric stud	46	29	Base frame, disassembly and reassembly	105	77
Clutch magnet laminated cores	47	29	Block adjustment, tape cover	53	31
Code sensing lever and selector lever clearance	54	32	Block diagram, application	60	34
Comb, selector lever	45	28	Block diagram of distributor-transmitters	61	36
Contact bail end play, transmitter	43	28	Breakdown test, voltage	112	80
Contacts, stop pulse and	48	29	Camshaft, disassembly and reassembly	99	66
Cover, tape. (See Tape cover.)			Characteristics, technical	4	3
Cover, top. (See Top cover.)			Chart, troubleshooting	87	52
Distributor-transmitter driving gear and driven gear	41	27	Checking unpacked equipment	10	6
Drive gearset	40	27	Checklist, operator first echelon maintenance	23	13
Driving gear and driven gear backlash	42	27	Circuit connections, signal	17	10
Eccentric stud, clutch magnet armature	46	29	Circuit descriptions:		
End play:			Ac circuits	74-76	44
Selector lever	44	28	Dc send circuit	77	47
Transmitter contact bail	43	28	Cleaning procedure	81	51
Friction clutch	57	33	Clearance adjustment:		
Gearset, drive	40	27	Code sensing lever and selector lever	54	32
Laminated cores, clutch magnet	47	29	Tape cover	52	31
Preliminary, top cover	51	31	Clutch, friction. (See Friction clutch.)		
Selector lever and code sensing lever clearance	54	32	Clutch magnet armature eccentric stud adjustment	46	29
Selector lever comb	45	28	Clutch magnet control	15	10
Selector lever end play	44	28	Clutch magnet laminated cores adjustment	47	29
Spring, tape-out lever	49	30	Clutch magnet L1, disassembly and reassembly	101	70
Stop pulse and contacts	48	29	Code sensing lever and selector lever clearance adjustment	54	32
Switch bail lever, upper	56	33	Code sensing levers, disassembly and reassembly	97	63
Tape cover:			Code, start-stop, five-unit	59	34
Block	53	31	Code transmitting mechanism	71	41
Clearance	52	31	Comb adjustment, selector lever	45	28
Tape guide	50	31	Common names	6	4
Tape guide, tape cover	50	31	Components, table	5	4
Tape-out lever spring	49	30	Compression spring data	109	79
Top cover	55	32			
Top cover preliminary	51	31			
Transmitter contact bail end play	43	28			
Upper switch bail lever	56	33			

	Paragraphs	Page		Paragraphs	Page
Connections:			Disassembly and reassembly—Continued		
Ground and power	12	8	Series-governed motor (TT-123A/FG)	91	57
Signal circuit	17	10	Synchronous motor (TT-122A/FG)	90	54
Contact bail end play adjustment, transmitter	43	28	Tape-out sensing mechanism	95	61
Contacts adjustment, stop pulse and	48	29	Terminal board TB1	101	70
Contacts, transmitter, disassembly and reassembly	100	67	Transmitter contacts	100	67
Control, clutch magnet	15	10	Disassembly for shipment and limited storage	115	82
Control lever mechanism	66-68	39	Distributor-transmitter:		
Control mechanism	69	40	Adjustment procedures	39	26
Controls	18	10	Covers, disassembly and reassembly	94	60
Covers, distributor-transmitter, disassembly and reassembly	94	60	Description	7	4
Crossed-end spring data	107	78	Driving gear and driven gear alignment	41	27
Data, description	3	3	Driving gear and driven gear backlash adjustment	42	27
Data, spring:			Frame, disassembly and reassembly	102	70
Crossed-end	107	78	Removal and replacement	93	60
Extension	109	79	Drive gearset adjustment	40	27
Parallel-end	108	79	Driving gear and driven gear backlash adjustment	42	27
Special	110	79			
Dc send circuit	77	47	Eccentric stud adjustment, clutch magnet armature	46	29
Demolition, authority	117	82	Electrical components, base, disassembly and reassembly:		
Description and data	3	3	TT-122A/FG	103	71
Description of Distributor-Transmitter, Teletypewriter TT-122A/FC and TT-123A/FG	7	4	TT-123A/FG	104	75
Destruction, methods	118	82	Electrical troubles, localizing	85	52
Detailed lubrication instructions	34	22	End play adjustment:		
Diagram, block	60, 61	34, 36	Selector lever	44	28
Differences in models	8	5	Transmitter contact bail	43	28
Disassembly and reassembly:					
Base electrical components:			Feed mechanism, tape	72	42
TT-122A/FG	103	71	Filter FL1, disassembly and reassembly	101	70
TT-123A/FG	104	75	Final testing	111	80
Base frame	105	77	First echelon maintenance checklist, operator	23	13
Camshaft	99	67	Five-unit code, standard start-stop	59	34
Clutch magnet L1	101	70	Forms and records	2	3
Code sensing levers	97	63	Frame, distributor-transmitter, disassembly and reassembly	102	70
Contacts, transmitter	100	67	Friction clutch:		
Covers, distributor-transmitter	94	60	Adjustment	57	33
Distributor-transmitter:			Preliminary check	13	8
Covers	94	60	Theory	65	38
Frame	102	70			
Electrical components, base:			Gear alignment, distributor-transmitter driving and driven	41	27
TT-122A/FC	103	71	Gearset adjustment, drive	40	27
TT-123A/FG	104	75	General lubrication instructions	33	21
Filter FL1	101	70	General preventive maintenance techniques	27	16
Frame, distributor-transmitter	102	70	Governor (TT-123A/FG):		
Governor, motor	92	59	Disassembly and reassembly	92	59
Motor:			Theory	63	38
Series-governed (TT-123A/FG)	91	57	Ground and power connections	12	8
Synchronous (TT-122A/FG)	90	54			
Motor dust cover	105	77	Inspection procedure	80	50
Motor governor	92	59	Inspection, visual	36	25
Operating levers	96	62			
Power shaft	105	77			
Selector levers	98	66			

	Paragraphs	Page		Paragraphs	Page
Instructions, general lubrication	33	21	Operator first echelon maintenance checklist	23	13
Introduction	5	4	Operator maintenance:		
Laminated cores adjustment, clutch magnet	47	29	Materials required	22	13
Limited storage, shipment	115	82	Scope	21	13
Line connections, signal	16	10	Operator's maintenance	24	13
Line-up, circuit	17	10	Organizational maintenance	21	13
Localizing troubles:			Organizational maintenance level, troubleshooting	35	25
Electrical	85	52	Parallel-end spring data	108	79
Mechanical	86	52	Power connections, ground and	12	8
Local test	16	10	Power distribution	64	38
Lubricants, recommended	30	19	Power shaft, disassembly and reassembly	105	77
Lubrication:			Preliminary adjustment, top cover	51	31
Assembly and operational test	83	51	Preparation for lubrication	32	20
Detailed instructions	34	22	Prerepair procedures	78	50
General instructions	33	21	Preventive maintenance techniques, general	27	16
Preparation	32	20	Procedures, operating	18	10
Recommended schedule	31	19	Purpose and use	3	3
Maintenance:			Reassembly. (See Disassembly and reassembly.)		
Checklist, operator first echelon	23	13	Receipt of equipment, service	9	6
Materials and test equipment (field)	79	50	Recommended lubricants	30	19
Materials and tools required (second echelon)	26	16	Recommended lubrication schedule	31	19
Materials required, operator	22	13	Records, forms	2	3
Operator's	24	13	Removal and replacement:		
Organizational	21	13	Distributor-transmitter	93	60
Scope of operator	21	13	Motor	89	54
Second echelon	25	16	Repacking for shipment and limited storage	116	82
Technician's	28	16	Replacement. (See Removal and replacement.)		
Techniques, general preventive	27	16	Rustproofing and painting	82	51
Troubleshooting at organizational level	35	25	Schedule, recommended lubrication	31	19
Materials required:			Scope:		
Operator maintenance	22	13	Operator maintenance	21	13
Second echelon maintenance	26	16	Second echelon maintenance	25	16
Mechanical theory	61-73	36	Sectionalizing trouble	37	25
Mechanical troubles, localizing	86	52	Selector lever and code sensing lever clearance adjustment	54	32
Methods of destruction	118	82	Selector lever comb adjustment	45	28
Models, differences	8	5	Selector lever end play adjustment	44	28
Motor:			Selector levers, disassembly and reassembly	98	66
Dust cover, disassembly and reassembly	105	77	Sending test setup	113	81
Governor disassembly and reassembly	92	59	Sensing levers, code. (See Code sensing levers.)		
Removal and replacement	89	54	Sensing mechanism, tape-out. (See Tape-out sensing mechanism.)		
Series-governed, disassembly and reassembly	91	57	Series-governed motor (TT-123A/FG), disassembly and reassembly	91	57
Synchronous, disassembly and reassembly	90	54	Service on receipt of equipment	9	6
Theory	62	36	Shipment and limited storage:		
Mounting	11	8	Disassembly	115	82
Names, common	6	4	Repacking	116	82
Operating levers, disassembly and reassembly	96	62	Repacking	116	82
Operating procedures	18	10	Signaling code	59	34
Operational test, lubrication, and assembly	83	51	Signal line connections	17	10

	Paragraphs	Page		Paragraphs	Page
Special spring data	110	79	Test equipment and maintenance ma-		
Spring adjustment, tape-out lever	49	30	terials (field maintenance)	79	50
Spring data:			Test setup, sending	113	81
Crossed-end	107	78	Testing, final	111	80
Extension	109	79	Testing procedures, starting	19	11
Parallel-end	108	79	Theory, distributor-transmitter me-		
Special	110	79	chanical	61-73	36
Standard start-stop, five-unit code	59	34	Tools and maintenance materials re-		
Starting and testing procedures	19	11	quired (second echelon)	26	16
Stopping procedure	20	12	Tools (field maintenance)	78	50
Stop pulse and contacts adjustment	48	29	Top cover adjustment	55	32
Switch bail lever adjustment, upper	56	33	Top cover preliminary adjustment	51	31
Synchronous motor (TT-122A/FG),			Transmitter contact bail end play ad-		
disassembly and reassembly	90	54	justment	43	28
Table of components	5	4	Transmitter contacts, disassembly and		
Tape cover:			reassembly	100	67
Block adjustment	53	31	Transmitting mechanism, code	71	41
Clearance adjustment	52	31	Trouble, sectionalizing	37	25
Tape guide adjustment	50	31	Troubleshooting:		
Tape feed mechanism	72	42	Chart	87	52
Tape guide adjustment, tape cover and	50	31	Field maintenance level	84	52
Tape-out lever spring adjustment	49	30	Organizational maintenance level ..	35	25
Tape-out sensing mechanism, disassem-			Using equipment performance		
bly and reassembly	95	61	checklist	38	26
Tape sensing mechanism	70	41	Unpacked equipment, checking	10	6
Technical characteristics	4	3	Unpacking	9	6
Technician's maintenance	28	16	Upper switch bail lever adjustment	56	33
Terminal board TB1, disassembly and			Use, purpose	3	3
reassembly	101	70	Visual inspection	36	25
Test:			Voltage breakdown test	112	80
Sending	114	81			
Voltage breakdown	112	80			

BY ORDER OF THE SECRETARIES OF THE ARMY AND THE AIR FORCE:

MAXWELL D. TAYLOR,
General, United States Army,
Chief of Staff.

OFFICIAL:

HERBERT M. JONES,
Major General, United States Army,
The Adjutant General.

THOMAS D. WHITE,
Chief of Staff, United States Air Force.

OFFICIAL:

J. L. TARR,
Colonel, United States Air Force,
Director of Administrative Services.

Distribution:

Active Army:

ASA
CNGB
Technical Stf, DA
Technical Stf Bd
USA Arty Bd
USA Armor Bd
USA Inf Bd
USA Air Def Bd
USA Abn & Elct Bd
USA Avn Bd
USA Armor Bd Test Sec
USA Air Def Bd Test Sec
USA Arctic Test Bd
USCONARC
US ARADCOM
OS Maj Comd
MDW
Armies
Corps
Div
USATC
Ft & Camp
Svc Colleges
Br Svc Sch
Gen Depots
Sig Sec, Gen Depots
Sig Depots
Fld Comd, AFSWP
Engr Maint Cen
Army Pictorial Cen

WRAMC
AFIP
AMS
Port of Emb (OS)
Trans Terminal Comd
Army Terminals
OS Sup Agcy
USA Sig Pub Agcy
USA Sig Comm Engr Agcy
USA Comm Agcy
TASSA
USA Sig Eqp Spt Agcy
USA White Sands Sig Agcy
Yuma Test Sta
USA Elect PG
Sig Fld Maint Shops
Sig Lab
Mil Dist
JBUSMC
Units org under fol TOE:
11-7
11-16
11-57
11-127
11-128
11-500 (AA-AE)
11-557
11-587
11-592
11-597

NG: State AG; Units—same as Active Army.

USAR: None.

For explanation of abbreviations used, see AR 320-50.

TM 11-2277/TO 31W4-2FG-1141 TELETYPEWRITER DISTRIBUTOR-TRANSMITTERS TT-122A/FG AND TT-123A/FG-1958