

THIS SUPPLEMENT WILL
REMAIN IN EFFECT ONLY
UNTIL THE INFORMATION
IS PUBLISHED IN AN OF-
FICIAL DEPARTMENT OF
THE ARMY PUBLICATION.

SUPPLEMENT
28 November 1951

SUPPLEMENT TO
TM 11-2234
TELETYPEWRITER TT-4/TG

The following information, published on Order No. 1671-Phila-51, supplements TM 11-2234, April 1951. The serial numbers of the equipment covered in this supplement are:

<i>Name</i>	<i>Serial numbers</i>
Teletypewriter TT-4A/TG	1392 and subsequent numbers

Personnel using this equipment and having custody of this technical manual will enter suitable notations beside each affected paragraph and figure in the technical manual to indicate the presence of this supplementary information.

Note. Teletypewriter TT-4A/TG is basically the same as Teletypewriter TT-4/TG. All information contained in TM 11-2234 covering Teletypewriter TT-4/TG applies equally to Teletypewriter TT-4A/TG, except as otherwise indicated in this supplement. In the first models of Teletypewriter TT-4/TG, fuse F1 in the motor circuit was a 2-ampere, 250-volt fuse. Later, a 1.6-ampere, 250-volt fuse was substituted and now is used on all Teletypewriters TT-4/TG and TT-4A/TG. Therefore, wherever in text and illustrations in the technical manual F1 is designated as a 2-ampere, 250-volt fuse, change the designation to read: 1.6-ampere, 250-volt. The unshift-on-space feature has been eliminated in Teletypewriter TT-4A/TG; the LINE FEED may be adjusted for single or double line spaces; the keyboard transmitter is improved; the method of suppressing radio interference is simplified; the carriage-feeding and carriage-return mechanisms are improved; a new selector cage assembly is supplied to insure stability of the code rings; the platen supporting bracket and the platen knob are changed; and the immersible cover base is welded instead of riveted.

Page 1. Par. 3. Delete subparagraph *b* (2) and substitute the following:

(2) Three standard operating speeds are possible: 368.1, 404, and 600 opm (operations per minute) (approximately 60, 66, and 100 wpm (words per minute)), respectively as determined by the motor-drive gear set in use. All teletypewriters TT-4A/TG are geared for 368.1 opm (60 wpm) when delivered by the manufacturer. In earlier models of Teletypewriter TT-4/TG alternate 404-opm gears were supplied as equipment accessories. However, in more recent models and those covered by this supplement, 600-opm gears (100 wpm operation) are furnished as equipment accessories in place of the 404-opm gears. The 404-opm gears must be installed in place of the normal 368.1-opm gears when this teletypewriter and British teleprinters are used on the same circuits. If using organizations experience the need of interoperation with British equipment and require 404-opm gears, the gears may be obtained through the regular supply channels. Signal Corps stock numbers for the alternate sets of gears are: 4TK50351 for the worm gear and 4TK50353 for the motor pinion for 404-opm operation, and 4TK50597 for the worm gear and 4TK50596 for the motor pinion for 600-opm operation.

Page 5. Fig. 5. In figure 5, change "404-opm" (in two places) to read: 600 opm.

Page 8. Par. 13. In subparagraph *b*, lines 3 and 4, change the words "in either direction" to read: inwardly.

Page 10. Par. 16. Make the following changes in the column headed "Signal Corps Stock No.":

Insert the following stock numbers:

4TTT4 for teletypewriter.

6F300-694 for Case CY-694/PGC-1.

4TK50996A for tuning fork.

Change the following stock numbers:

"3Z2585.2" for $\frac{1}{8}$ -amp fuse to read: 3Z2585

"4T80827" for incandescent lamp to read:

6Z6820-2.2.

Page 12. Par. 17. Under "Functions" (space bar), delete: Unshifts from FIGS to LTRS when struck during FIGS operation $\text{\textcircled{g}}$.

Page 13. Par. 17. Delete footnote *g* following paragraph 17.

Page 13. Par. 18. Make the following changes in paragraph 18:

In subparagraph *c*, line 4, change "90" to read: 150.

In subparagraph *d*, line 4, change "95" to read: 213.

Page 14. Par. 19. Make the following changes in paragraph 19:

In subparagraph *g*, change "(par. 32)" to read: (par. 41).

In subparagraph *h*, change "(par. 33)" to read: (par. 58).

Page 17. Par. 26. In the last line of subparagraph *b*, change "par. 21b" to read: par. 22.

Page 19. Par. 29. Make the following changes in paragraph 29:

In subparagraph *a*, line 7, change "404-opm" to read: 600-opm.

In line 11, change "404-opm" to read: 600-opm and change "600-opm" to read: 404-opm.

In line 13, change "600" to read: 404.

In subparagraph *a*(1), lines 1 and 6, change "404" to read: 600.

In line 7, change "50351" to read: 50596.

In lines 10 and 12, change "404" to read: 600

In line 12, change "50353" to read: 50597.

In line 20, change "404" to read: 600.

Add the following after subparagraph *a*(1):

(*a*) When changing from 368.1 opm to 600 opm, or vice versa, be sure to adjust the printing bail (par. 236), the platen shift (par. 243), and all friction clutches to give the best printing.

In subparagraph *a*(2), lines 1, 2, and 4, change "600" to read: 404.

In line 3, change "404" to read: 600.

Delete subparagraph *b*.

In subparagraph *c*, line 8, change "70" to read: 69.

Delete subparagraph *c*(2).

In subparagraph *c*(3), line 1, change "70" to read: 69.

Page 20. Fig. 14. Change "404" (in two places) to read: 600, change "50353" to read: 50597, and change "50351" to read: 50596.

Page 20. Par. 30. Make the following changes in paragraph 30:

In the note following subparagraph *b*(2), lines 3 and 7, change "404" to read: 600.

In line 7, change "50351" to read: 50596.

In line 12, change " $\frac{3}{4}$ " to read: $\frac{9}{16}$ and delete the words "being the smaller of the two worms" and insert the following: having four threads instead of six.

In line 13, change "50352" to read: 50352A.

In line 14, change "404" to read: 600.

In line 15, change "50353 is $2\frac{1}{32}$ " to read: 50597 is $1\frac{3}{32}$.

Delete subparagraph *b*(3).

In subparagraph *b*(4), line 4, change "70" to read: 69.

Page 31. Par. 43. In the column of the table headed "Purpose and use" (opposite space bar), delete the sentence, Also automatically unshifts * * * eliminated by adjustment.

Page 33. Par. 44. In the column of the table headed "Purpose and use" (opposite Motor-gover-

nor-adjustment worm), change the words "Turn clockwise" to read: Push in and change the words "Turn counterclockwise" to read: Pull out.

Page 33. Par. 45. At the bottom of page 33 in the column of the table headed "Control or device" add: Platen feed.

In the column "Location" add: Left-hand end of platen (figs. 174, 174.5).

In the column headed "Purpose and use" add: Adapts platen for single or double line spacing.

Page 45. Par. 57. Make the following changes in paragraph 57:

In subparagraph *a*(1)(*c*), line 12, delete the sentence, "Always remember that * * * eliminated by adjustment)."

In the last line of subparagraph *b*(6), change "63d" to read: 66th.

Page 48. Par. 62. In line 3, change "211" to read: 213.

Page 70. Par. 77. Make the following changes in paragraph 77:

In subparagraph *b*, item 2, change "Capacitors C10, C11, C17, and C19" to read: Capacitors C16 and C17:

In subparagraph *c*, delete item 4. (The capacitors have been replaced by filter Z2.)

In subparagraph *e*, item 4, change "C9" to read: C15.

Page 82. Fig. 49. Delete figure 49 and insert new figure 49.

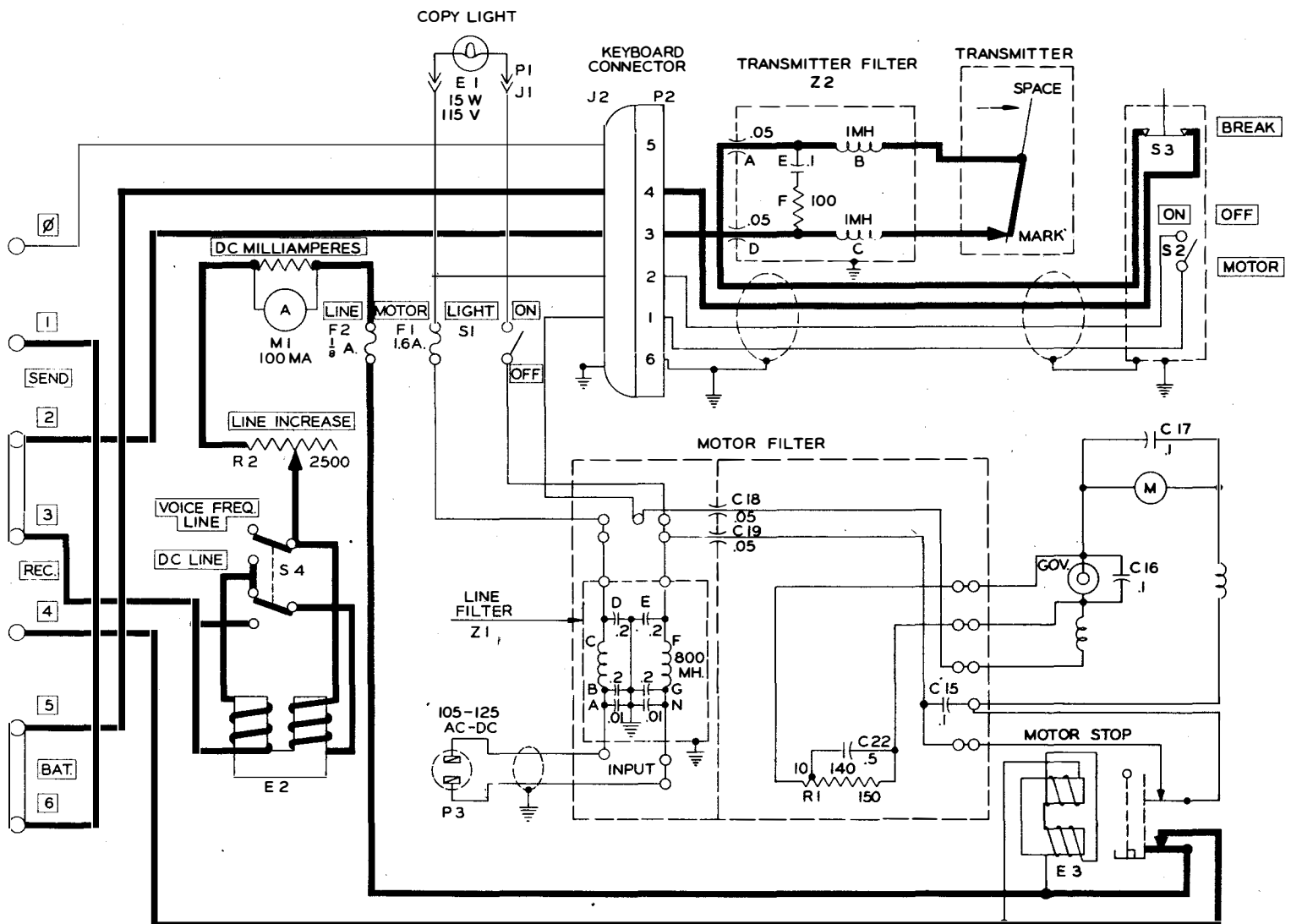

Figure 49. Teletypewriter TT-4A/TG, schematic diagram.

TM 2234-C1-3

Page 83. Par. 91. In lines 8 and 9, change "(fig. 51)" to read: (fig. 49).

Page 84. Fig. 51. Delete figure 51.

Page 85. Par. 93. In line 10, change "404" to read: 600.

Page 85. Par. 94. Add the following "note" at the end of the paragraph:

Note. In Teletypewriter TT-4A/TG, the driving fork for the transmitter is secured to the transmitter shaft and the clutch plates are secured to the transmitter drive shaft.

Page 86. Fig. 55. In figure 55, change the words "driving shaft" to read: "driven shaft" and change the words "driven shaft" to read: "driving shaft."

Page 86. Par. 95. Make the following changes in paragraph 95:

In line 2 of the opening statement change "56" to read: 49.

In subparagraph *d*, delete "Induction coils L5 * * * through C15 are" and substitute the following: Transmitter filter Z2 is.

Page 86. Par. 96. Make the following changes in paragraph 96:

In subparagraph *a*, line 16, change the word "space" to read: code.

In subparagraph *a* (2), line 26, delete the word "opens" and substitute the following: permits the contact bail spring to open.

In subparagraph *b* (3), delete "The start impulse * * * or start impulse," and substitute the following: As soon as the camshaft starts turning, all the cams are disengaged from the selector levers and the transmitter contact bail spring pulls the contact bail down and opens the contacts. This happens before the first five-unit, code-impulse cam lifts its selector lever.

In subparagraph *b* (4), line 8, change the word "seventh" to read: sixth and in line 9, delete the word "start" and substitute the following: last code.

Page 86. Fig. 56. Delete figure 56.

In subparagraph *e*, (chart A), make the following changes:

Item 6. Change "No. 7" to read: No. 6.

Item 7. Delete item 7 and substitute the following: All selector levers disengage moving contact arm.

Item 8. Delete the phrase "Upper end of No. 6 selector lever" and substitute the following: Contact bail spring.

Item 11. Delete the phrase "upper end of selector lever No. 1" and substitute the following: contact bail spring.

Items 16 and 17. Change "No. 7" to read: No. 6.

In "Sending Sequence Chart B", items 6 and 7, change "No. 7" to read: No. 6.

Page 92. Par. 98. In subparagraph *a*, line 6, change the word "stuck" to read: struck.

Page 102. Fig. 74. In figure 74, delete the word "space".

Page 102. Par. 104. In subparagraph *f*, delete "Space (bar controlled), with LTRS shift 111."

Page 103. Fig. 76. Delete the word "space" in two places.

Page 104. Par. 106. Add the following after the table in subparagraph *d*:

e. Teletypewriter TT-4A/TG is provided with a blocking means for preventing the engagement of the carriage feed clutch if the carriage is in its extreme right-hand position. Figure 78.1 shows this means. As the carriage moves into the 72*d* space, the lower edge of the carriage-feed pawl moves between two of the teeth on the space ratchet and the carriage-feed blocking arm engages the feed pawl so that it cannot release the ratchet to engage the feed clutch. This prevents undue strain on the carriage-feed shaft and gears should another key be struck before the carriage-return key is operated. If another key is so operated, the printed characters will be printed on top of each other. If 76-characters-per-line operation is desired, the pin may be turned 90° to increase the separation of the blocking arms.

Page 104. Fig. 78. Insert figure 78.1 after figure 78.

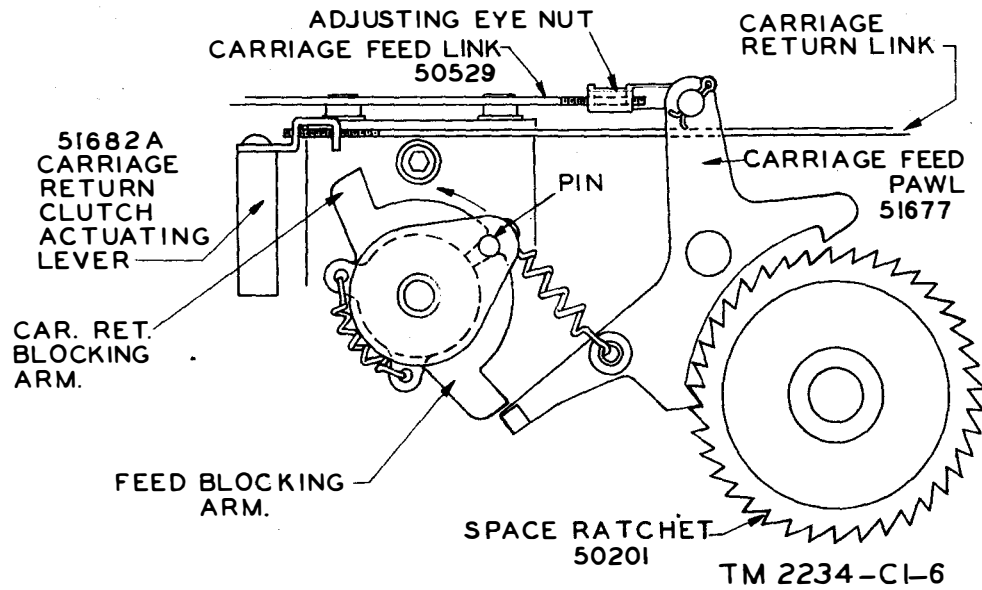

Figure 78.1. Carriage-feed blocking mechanism.

Page 105. Fig. 79. Insert figure 79.1 after figure 79.

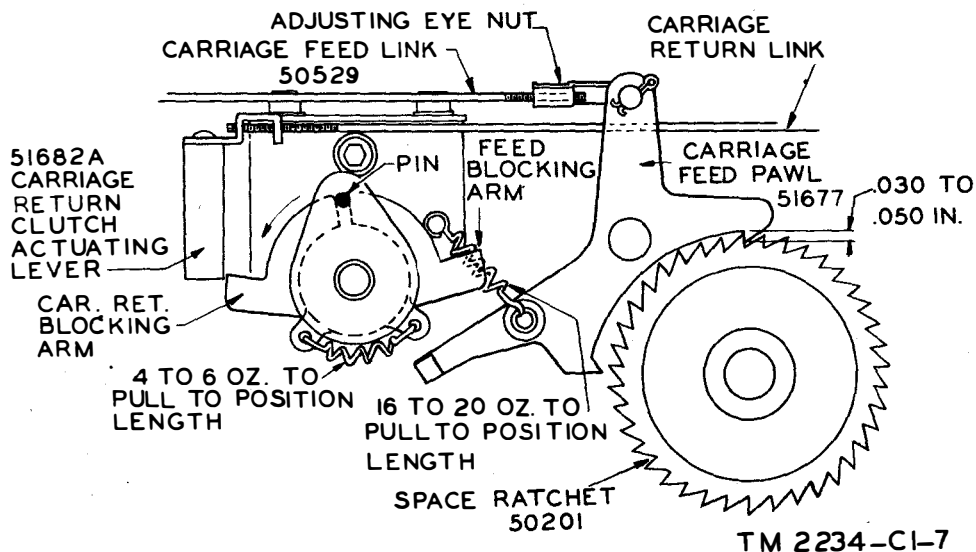

Figure 79.1. Carriage-return blocking mechanism.

Page 107. Par. 107. Add the following after subparagraph f:

g. The carriage-return clutch cannot be engaged when the carriage is in its extreme left-hand position because a portion of the carriage-return-clutch-actuating-lever will engage the end of a carriage-return blocking arm. The actuating clutch lever cannot move; therefore the clutch cannot be en-

gaged. As soon as the carriage is moved one space, the carriage-return blocking arm (fig. 79.1) moves downward enough to clear the end of the clutch-actuating-lever so that it can move (if a carriage-return signal is received) sufficiently to operate the carriage-return clutch.

Page 107. Par. 108. Make the following changes in paragraph 108:

Change the first sentence to read: The platen is turned to feed the paper one or two line spaces by the operation of the LINE FEED key, depending upon the position of the adjustable pawl stop. A, figure 174.1 shows pawl stop 51763 positioned for single-line spacing and B, figure 174.1 shows it set for double-line spacing.

In subparagraph a, change the first sentence to read: The platen can either be held in a given position or be turned one or two line spaces

at a time by the detent wheel rigidly attached to it.

In the third sentence after "one space", insert the following: or two spaces. Change the sixth sentence to read: After the platen has been turned one or two line spaces, the detent catches the next tooth or the next two teeth to hold the platen in the advanced position.

Page 109. Fig. 81. Delete figure 81 and insert new figure 81.

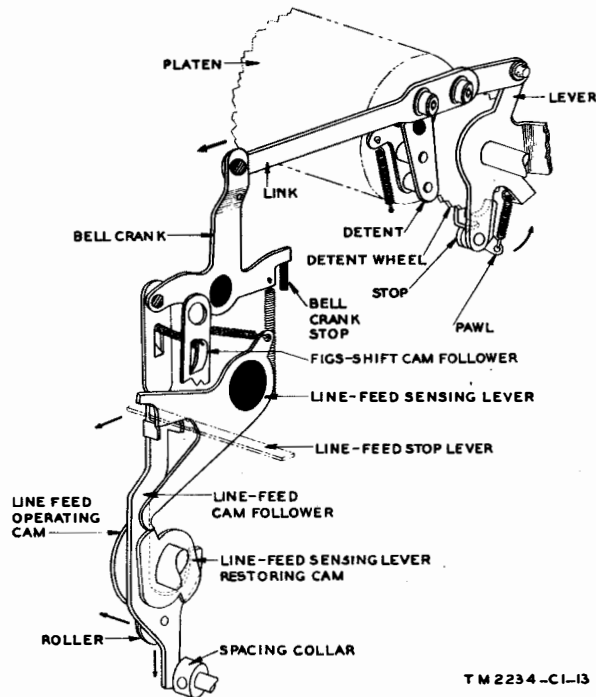
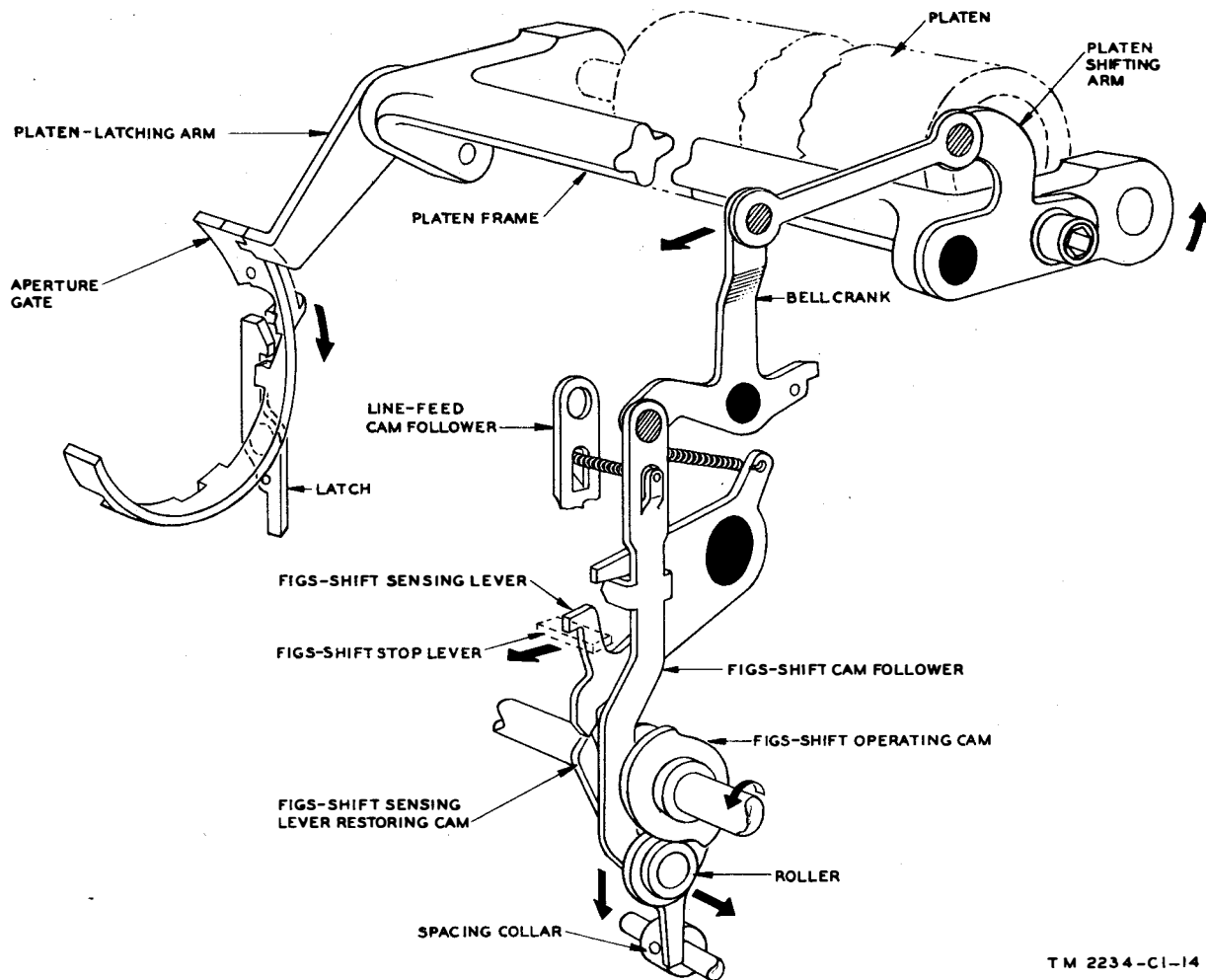

Figure 81. LINE FEED mechanism.

Page 110. Fig. 82. Delete figure 82 and insert new figure 82.



TM 2234-C1-14

Figure 82. FIGS-shift mechanism.

Page 111. Fig. 84. Delete figure 84.

Page 111. Par. 111. Make the following changes in paragraph 111:

Delete subparagraph *b*. (The unshift-on-space function is eliminated in Teletypewriter TT-4A/TG.)

In the table of subparagraph *c*, make the following changes:

Item 7. Delete "Intermediate lever turned".

Item 8. Delete "Unshift lever turned".

Item 9. Delete "Aperture gate unlatched".

Item 10. Delete "Platen returns to * * * in FIGS shift)".

Page 112. Par. 113. In subparagraph *b*, line 17, change "85" to read: 86.

Page 124. Par. 131. In the last line of the "Note" after subparagraph *b*, change "61" to read: 72.

Page 126. Par. 135. Make the following changes in the chart:

Item 1c. Change "par. 198" to read: par. 189 and change "par. 248" to read: par. 264.

Item 2c. Change "par. 188" to read: par. 189.

Item 3g. Change pars. 208, 224 to read: pars. 223-225.

Item 3k. Change pars. 144, 157 to read: pars. 154, 157.

Item 33, *a*, *b*, and *c*. Change "par. 7" to read: pars. 13 and 77.

Page 135. Fig. 102. In figure 102, change "50730" to read: 50730A.

Page 136. Fig. 103. Delete figure 103.

Page 133. Par. 140. Make the following changes in paragraph 140:

In subparagraph *b* (1) (*c*), change "50730" to read: 50730A.

In subparagraph *c* (2) (*a*), change "Shims 50986 are in place." to read: Enough shims 50986 are

in place to provide running clearance between the gears.

In subparagraph *d*(1) (*e*) change "50849A" to read: 51545A.

In subparagraph *e*(1) (*b*), change "four" to read: two

Change "50202A" to read: 51461A.

In subparagraph *e*(2) (*d*), change "four" to read: two.

Page 138. Fig. 105. In figure 105, change "50640A" to read: 51441A.

Change "50849A" to read: 51545A.

Delete "50484A".

Page 140. Fig. 107. In figure 107, change "50640A" to read: 51441A.

Page 140. Par. 141. Make the following changes in paragraph 141:

In subparagraph *a*(1), line 2, change "51151" to read: 51155.

In subparagraph *a*(3), line 7, change "10926" to read: 51060.

Page 141. Fig. 108. Add the following after the caption,

(Does not show latest motor.)

Page 145. Par. 150. Make the following changes in paragraph 150:

In subparagraph *a*, change "50711A" to read: 51588A.

In subparagraph *a*(1), change "50810A" to read: 51579A.

In subparagraph *a*(2), delete "Loosen the set-screw * * * holds contact 50711A" and substitute the following: Unsolder the leads from contacts 51588A.

Page 145. Par. 151. Make the following changes in paragraph 151:

In subparagraph *a*, change "50626A" to read: 51582A.

In subparagraph *a*(1), change "50711A" to read: 51588A.

Delete the material in subparagraph *a*(2) and substitute the following: Loosen but do not remove socket head screws 10009.

In subparagraph *a*(3), change "50626A" to read: 51582A.

Change "50633A" to read: 51595A.

In subparagraph *a*(4), change "50945" to read: 51548.

After subparagraph *a*(4), insert the following:
(4.1) Raise the contact plate 51611A on loosened screws 10009.

In subparagraph *a*(5), delete the words "nut, lockwasher, and flat washer", and insert the following: Truarc ring.

Change "hold" to read: holds.

Change "50626A" to read: 51582A.

Change "50639" to read: 51581.

Change "50625A" to read 51582A.

In the last sentence of subparagraph *b*, change "258" to read: 259.

Page 146. Fig. 112. Delete figure 112 and substitute the following:

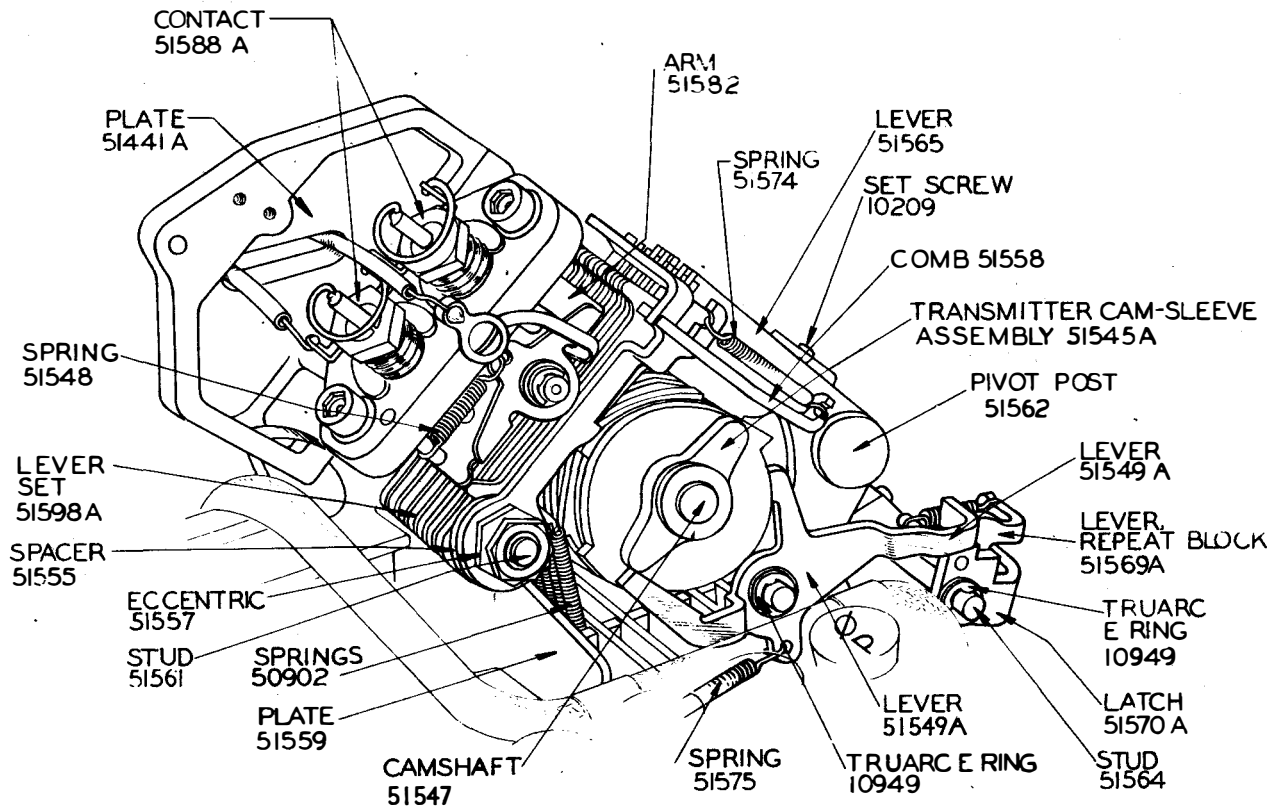

TM 2234-CI-8

Figure 112. Transmitter Parts.

Page 146. Par. 154. Make the following changes in paragraph 154:

In subparagraph *a*, change "50618" to read: 51549A.

In subparagraph *a* (1), change "50810A" to read: 51579A.

Delete subparagraphs *a* (2) and *a* (3) and substitute the following:

(2) Remove the screw and lockwasher from the front of switchbox cover 50703 and raise the cover.

(3) Remove screws 50207 from the ends of guide 50692A (fig. 114) and lower the keybar comb.

In subparagraph *a* (4), change "50946" to read: 51575.

In subparagraph *a* (5), change "washer 50839" to read: Truarc ring.

Change "50618" to read: 51549A.

Delete "slightly to clear * * * clear guide 50623".

In subparagraph *b*, change "50619" to read: 51598A.

Page 146. Par. 155. Make the following changes in paragraph 155:

In subparagraph *a*, change "51069" to read: 51598A.

In subparagraph *a* (1), delete the phrase "locking lever (par. 155)" and insert the following: transmitter contact cover 51579A.

In subparagraph *a* (2), change "50633A" to read: 51595A.

In subparagraph *a* (3), change "50945" to read: 51548.

In subparagraph *a* (4), change "50633A" to read: 51611A.

Change "50640A" to read: 51441A.

Delete subparagraph *a* (5) and substitute the following: (5) Remove the moving-contact arm (par. 151).

Delete subparagraphs *a* (6) through *a* (10) and substitute the following:

(6) Remove locking bail 51567 by unhooking spring 51574, remove nut on pivot 51561, pull bail from pivot and twist slightly to clear comb 51558.

(7) Remove sensing levers 51573A by loosening the setscrew which holds post 51562 in mounting 51441A; pull post 51562 just out of mounting and raise the sensing levers 51573A as a group from comb and code bars.

(8) Remove comb 51558 by unscrewing the two mounting screws.

(9) Remove spacing collar 51555 from selector-pivot stud 51561.

(10) Remove the six selector levers (lever set 51598A), the six pivot bearings 51644A under each lever, and the six washers 50147 between each pair of levers by pulling, one at a time, forward to clear stud 51561. Unhook one spring 50902 from each selector lever as the levers are removed.

In subparagraph *b*, line 2, change the word "seven" to read: six, and change "51069" to read: 51598A.

In line 5 change "50019" to read: 51627.

Page 147. Fig. 113. In figure 113, change "50703" to read: 51378A, change "50849A" to read: 51545A, change "50640A" to read: 51441A, and change "50620" to read: 51594.

Delete "C3, C4, C13, C14, L5, L6, and cover 51046A." (These have been replaced by filter Z2.)

Page 148. Par. 156. Make the following changes in paragraph 156: Delete subparagraphs *a*, *a*(1) through *a*(5) and *b*, and substitute the following:

a. REMOVAL. To remove any of the five sensing levers 51565 (fig. 112), proceed as follows:

(1) Loosen setscrew 10209 which holds pivot post 51562 in plate 51441A.

(2) Pull post 51562 forward until it clears mounting plate 51441A.

(3) Raise post and sensing levers 51573A as a group from the comb and code bars.

(4) Remove sensing levers and spacers from post.

b. REPLACEMENT. To replace, reverse the above procedure.

Page 148. Par. 157. Make the following changes in paragraph 157:

In subparagraph *a*, change "50849A" to read: 51545A.

In subparagraph *a*(2), delete "friction clutch (par. 153)," and insert the following: fork assembly 50484A, by loosening the set screws and pulling the assembly off the shaft.

In subparagraph *a*(3), change "50618" to read: 51567.

In subparagraph *a*(4), change "50849A" to read: 51545A.

Page 148. Fig. 114. In figure 114, change "50819" to read: 51560, change "50640A" to read: 51441A, and change "50703" to read: 51378A.

Page 149. Par. 159. In line 4, change "(par. 159)" to read: (par. 158).

Page 149. Par. 161. In subparagraphs *a*(5) and *a*(6), change "50703" to read: 51378A.

Page 149. Par. 162. Make the following changes in paragraph 162:

In subparagraph *a*(2), change "50810A" to read: 51579A.

In subparagraph *a*(3), change "50711A" to read: 51588A.

In subparagraph *a*(4), change "51042" to read: 51663A.

In subparagraph *a*(7), change "50703" to read: 51378A.

In subparagraph *a*(8), delete the words "cover" and "three", and change "50640A" to read: 51441A.

In subparagraph *a*(9), change "50703" to read: 51378A (in two places).

In subparagraph *a*(10), change "50703" to read: 51378A, and change "cover 51042" to read: 51663A.

Page 149. Par. 163. Delete subparagraph *a*(2) and substitute the following:

(2) Remove the two code-bar-guide studs 51560 by unscrewing the screws on the back of plate 51441A. Pull the studs out. Be careful not to twist or bend the code bars. Unhook spring 51136 when removing universal bar 51134A.

Note. A keyboard comb 51566 is held in place on studs 51560 adjacent to plate 51441A.

Page 150. Par. 164. Make the following changes in paragraph 164:

In subparagraph *a*(1), change "57030A" to read: 51030A.

In subparagraph *a*(3), change the word "seven" to read: six.

Page 150. Par. 165. Make the following changes in paragraph 165:

In subparagraph *a*, change "50624 and 50625" to read: 51569 and 51570A, respectively.

In subparagraph *a*(1), change the phrase "50943 (not shown)" to read: 51544 (fig. 183) and change "50625" to read: 51570A.

In subparagraph *a*(2), change "50618" to read: 51567.

After the word "unscrew", add the following: the setscrew which holds.

Delete "50617", and substitute the following: 51564 in plate 51441A.

Page 151. Par. 171. Make the following changes in paragraph 171:

In subparagraphs *a*(5) and *a*(6), change "50153" to read: 51415.

Add the following after subparagraph *a*(7).

(8) Remove stud 51415 by loosening the set screw which holds it in frame 51031A.

In subparagraph *b*, line 6, after the word "levers" insert the following: that spacer 51416 is on the stud.

Page 151. Fig. 115. In figure 115, change "50153" to read: 51415.

Page 152. Fig. 116. In figure 116, change "50470A" to read: 51685A.

Page 154. Par. 178. In subparagraph *a*(1), change (par. 125*a*) to read: (par. 140*a*).

Page 155. Par. 179. Make the following changes in paragraph 179:

In subparagraph *a*, change "(fig. 119)" to read: (fig. 118).

In subparagraph *a*(1), change "(par. 125*a*)" to read: (par. 140*a*).

In subparagraph *a*(9), change "50470A" to read: 51685A.

In subparagraph *b*(3), change "50760" to read: 50759A.

In subparagraph *b*(4), change "5084A" to read: 50841A.

Page 157. Par. 183. In subparagraphs *a* and *a*(4), change "50754" to read: 51428.

Page 157. Fig. 119. In figure 119, change "50754" to read: 51428.

Page 158. Par. 189. In the last line of subparagraph *b*, change "248" to read: 264.

Page 159. Fig. 120. In figure 120, change "50527" to read: 51639 and change "50810A" to read: 51579A.

Page 161. Fig. 122. In figure 122, change "50527" to read: 51639. Delete the phrase "Nut 50210".

Page 161. Par. 195. Make the following changes in paragraph 195:

In subparagraph *a*, change "50527" to read: 51639.

In subparagraph *a*(1), change (par. 125*a*) to read: (par. 140*a*).

In subparagraph *a*(5), change the phrase "nut 50210" to read: ring and change "50257" to read: 51639.

Delete the words "by holding the nut * * * the motor clockwise".

In subparagraph *a*(8), change "50527" to read: 51639.

Page 162. Fig. 123. Make the following changes in figure 123:

In figure 123, delete the retainer 50265 and the bearing 10755. (These parts have been replaced in Teletypewriter TT-4A/TG by a retaining ring.)

Change "50187" to read: 51641 and change "51070" to read: 51643A.

Page 162. Par. 196. Make the following changes in paragraph 196:

In subparagraph *a*(2), change "12" to read: 9.

Delete subparagraph *a*(5) and substitute the following: (5) Remove Truarc retaining ring.

In subparagraph *b*, change "185" to read: 195.

Page 162. Par. 197. Make the following changes in paragraph 197:

In subparagraph *a*(1), change "50160" to read: 51690 and change "50113" to read: 51689.

In subparagraph *c*(1) (*a*) change "(par. 125*e*)" to read: (par. 140*e*).

In subparagraph *d*(1) (*a*) change "(par. 141*e*)" to read: (par. 140*e*).

In subparagraph *d*(1) (*b*) change "50164" to read: 51772.

In subparagraph *d*(1) (*c*), item 2, change "50188" to read: 51756A.

In subparagraph *d*(2), delete the note at the end of the subparagraph.

Page 163. Fig. 124. In figure 124, change "50188" to read: 51756A, "50113" to read: 51689, "50160" to read: 51690, "50240A" to read: 51687A, and "50170A" to read: 51759A.

Page 166. Par. 209. Make the following changes in paragraph 209:

In subparagraph *a*(7), change "(par. 190)" to read: (par. 191).

In subparagraph *a*(8), change "(par. 191)" to read: (par. 192).

Page 167. Par. 210. In paragraph 210, line 2, change "186" to read: 185.

Page 169. Par. 216. Make the following changes in the table in subparagraph *a* for the part numbers indicated:

In the column headed "Part No.", change "50943" to read: 51544, and change "50946" to read: 51575.

In the column headed "Free length (in.)":

50196, change " $1\frac{1}{16}$ " to read: $\frac{9}{16}$.

50575, change " $1\frac{1}{16}$ " to read: $1\frac{1}{8}$.

50905, change " $1\frac{1}{16}$ " to read: $2\frac{1}{32}$.

50906, change " $\frac{3}{4}$ " to read: $1\frac{1}{16}$.

50911, change " $\frac{7}{8}$ " to read: $1\frac{1}{16}$.

50912, change " $1\frac{7}{32}$ " to read: $\frac{1}{2}$.

51575, change " $\frac{9}{16}$ " to read: $\frac{3}{4}$.

50965, change " $2\frac{1}{32}$ " to read: $\frac{9}{16}$.

51136, change " $2\frac{9}{32}$ " to read: $1\frac{1}{16}$.

In the column headed "Extended length (in.)":

50196, change " $\frac{3}{4}$ " to read: $\frac{5}{8}$.

50575, change " $1\frac{1}{8}$ " to read: $1\frac{3}{8}$.

50911, change "1" to read: $1\frac{5}{16}$.

50916, change " $3\frac{3}{64}$ " to read: $\frac{1}{2}$.

50965, change " $2\frac{5}{32}$ " to read: $1\frac{1}{16}$.

51544, change " $1\frac{1}{16}$ " to read: $1\frac{1}{8}$.

51575, change " $1\frac{1}{16}$ " to read: $1\frac{3}{16}$.

In the column headed "Required tension at extended length (oz)":

- 50196, change "5½ to 6½" to read: ¾ to 1¼.
- 50334, change "34" to read: 30 to 34.
- 50575, change "½ to ¾" to read: 1 to 1½.
- 50678, after "1¾ to 2¼", add the following: lb.
- 50903, change "4¾ to 4¼" to read: 4¾ to 5¼ lb.
- 50906, change "9¾ to 10¼ lb" to read: 9½ to 10½.
- 50907, change "15 to 17" to read: 16 to 20.
- 50908, change "9" to read: 8½ to 9½.
- 50912, change "16 to 20" to read: 4 to 6.
- 51544, change "1⅜ to 1⅝" to read: 1¼ to 1¾.
- 50944, change "¼ to ½" to read: 1¾ to 2¼.
- 51575, change "28 to 32" to read: 2¼ to 2¾.
- 50965, change "15 to 17" to read: 11 to 13.
- 51136, change "7 to 14" to read: 15 to 20.

Page 170. Par. 216. Make the following changes in the table in subparagraph *b* for the part numbers indicated:

In the column headed "Free length (in.)":

- 50716, change "⅜" to read: 1⅜.
- 50847, change "1⅜" to read: ½.
- 50859, change "⅞" to read: ⅜.
- 50914, change "⅞" to read: 1⅜.
- 50922, change "⅞" to read: 1⅜.
- 51120, change "1⅜" to read: ¾.

In the column headed "Compressed length (in.)":

- 50416, change "⅝" to read: ⅜.
- 50847, change "⅝" to read: ⅞.
- 50859, change "⅝" to read: ⅞.
- 50914, change "⅝" to read: ⅞.
- 50922, change "⅝" to read: ⅞.

In the column headed "Required compression":

- 50154, change "12 to 14" to read: 11 to 15.
- 50716, change "7½ to 8½" to read: 9 to 11.
- 50847, change "6¾ to 7¼ lb at ⅜ in." to read: 8¾ to 9 lb. at ⅞ in.
- 50859, change "⅝" to read: ⅞.
- 50914, change "5¾ to 6¼ lb. at ⅝ in." to read: 4 to 5 lb. at ⅞ in.
- 50922, change "9¼ to 9¾ lb at ⅝ in." to read: 5¾ to 6¼ lb at ⅞ in.
- 51120, change "⅞" to read: 1⅞.

Page 171. Fig. 130. Change "50946" to read: 51575. Change "28 to 32 oz" to read: 2¼ to 2¾ oz.

Page 171. Fig. 131. Change "50943" to read: 51544. Change "1⅜ to 1⅝ oz" to read: 1¼ to 1¾ oz.

Page 171. Fig. 132. Change "¼ to ½ oz" to read: 1¾ to 2¼ oz.

Page 172. Fig. 138. Change "2 to 2½ oz" to read: 4½ to 5½ oz.

Page 172. Fig. 141. Change "15 to 17 oz" to read: 16 to 20 oz.

Page 173. Fig. 152. Change "5½ to 6½ oz" to read: ¾ to 1¼.

Page 174. Par. 219. In subparagraph *a*, line 1, change ".015-inch" to read: .010- to .020-inch.

Page 174. Fig. 153A. In figure 153A, mark the stud which supports the T-shaped levers: Eccentric.

Page 174. Fig. 153B. Change ".015 in." to read: .010 to .020 in.

Page 174. Par. 220. Add the following after paragraph 220:

220.1. T-shaped Lever Adjustment

a. REQUIREMENT. The points of the T-shaped levers should engaged the opposite arms of the Y-shaped levers an equal amount when they all are in the marking position as they do when they all are in the spacing position. To meet this requirement the T-shaped levers are mounted on an eccentric stud 50650 which permits the T-shaped levers to be adjusted sidewise.

b. ADJUSTMENT. (*This adjustment can be made best before the selector magnet is installed.*) Loosen the locknut which holds the eccentric stud in the transfer lever. Move all the Y-shaped levers and the selector code bars to the marking position. Trip the transfer lever. Note the amount of engagement between the Y-shaped levers and the T-shaped levers. Move all the Y-shaped levers and the selector code bars to the spacing position. Trip the transfer lever. Note the amount of engagement between the Y-shaped and T-shaped levers. Turn the eccentric stud and repeat the process until the engagement is equal in both marking and spacing positions. Tighten the locknut.

Page 174. Par. 221. Add the following after paragraph 221:

221.1. Orientation Lever Adjustment (fig. 93)

a. REQUIREMENT. The selector stop plate should be at its midpoint of operation with the rangefinder dial set at 60.

b. ADJUSTMENT. Set the rangefinder dial at 60. Loosen the screw which holds the cam on the shaft. Rotate the cam until the midpoint between the high and low spots is engaged by the orientation lever. Tighten the set screw in the cam. Hold the lower portion of the lever against the cam and adjust the eccentric supporting stud 50330 until the inside face of the upper end of the orientation lever is ⅝ inch from the face of the stop plate. Tighten the eccentric locknut.

Page 177. Fig. 161. In figure 161, change "40 to 42 oz" to read: 40 to 46 oz.

Page 177. Par. 227. In subparagraph *a*, change "40 to 42" to read: 40 to 46.

Page 177. Par. 230. In subparagraph *b*, line 1, change the word "two" to read: four.

Page 178. In figure 164 make the following changes:

Change ".031" to read: .015 to .046.

Change ".010 to .015" (on function-selecting arm) to read: .008 to .020.

Change ".040 to .050" to read: .010 to .020;

Change ".010 to .015 (on function-shaft clutch drum) to read: .010 to .025.

Page 178. Par. 231. In subparagraphs *a* and *b* (2), change ".031" to read: .015 to .046.

Page 178. Fig. 165. In figure 165, change "15 to 17 oz" to read: 12 to 17.

Page 178. Par. 232. In subparagraph *a*, line 1, change "15" to read: 12.

Page 179. Par. 233. In subparagraph *a*, line 1, change ".015" to read: .025.

Page 179. Par. 234. In subparagraph *a*, line 1, change ".040 to .050" to read: .010 to .020.

Page 179. Par. 236. Make the following changes in paragraph 236:

In the last line of subparagraph *a* (2), change ".015" to read: .008.

Add the following after subparagraph *a* (2):

Note. This adjustment should always be made when changing from 60 wpm operation to 100 wpm, or vice versa.

Page 180. Fig. 168. In figure 168, change ".015" to read: .008.

Page 180. Par. 237. In subparagraph *b*, line 4, delete one of the phrases "turn the."

Page 181. Par. 243. In subparagraph *a*, line 1, change ".010 to .015" to read: .005 to .020.

Page 181. Fig. 170. Delete figure 170 and insert new figure 170.

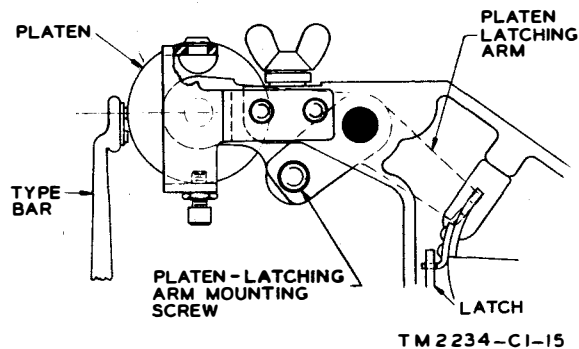

Figure 170. Platen in the FIGS-shift position, end view.

Page 181. Fig. 171. Delete figure 171 and insert new figure 171.

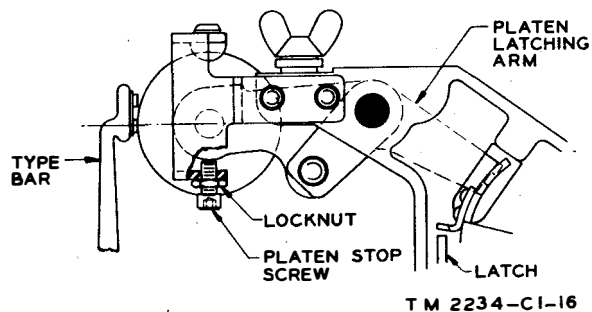

Figure 171. Platen in the LTRS-shift position, end view.

Page 181. Fig. 172. In figure 172, change ".010 to .015" to read: .005 to .020.

Page 182. Fig. 173. Delete figure 173 and insert new figure 173.

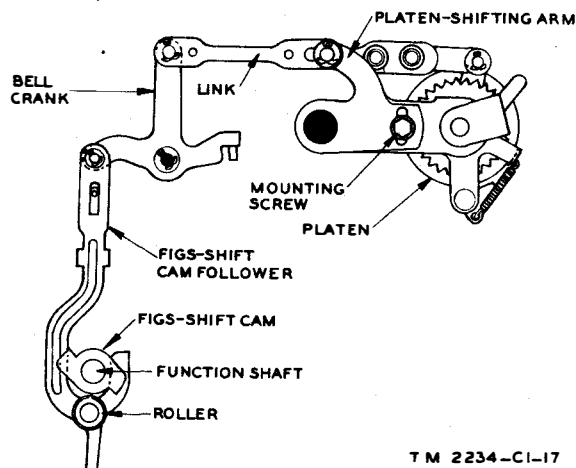

Figure 173. Platen-shifting mechanism, side view.

Page 182. Fig. 174. Delete figure 174 and insert new figure 174.

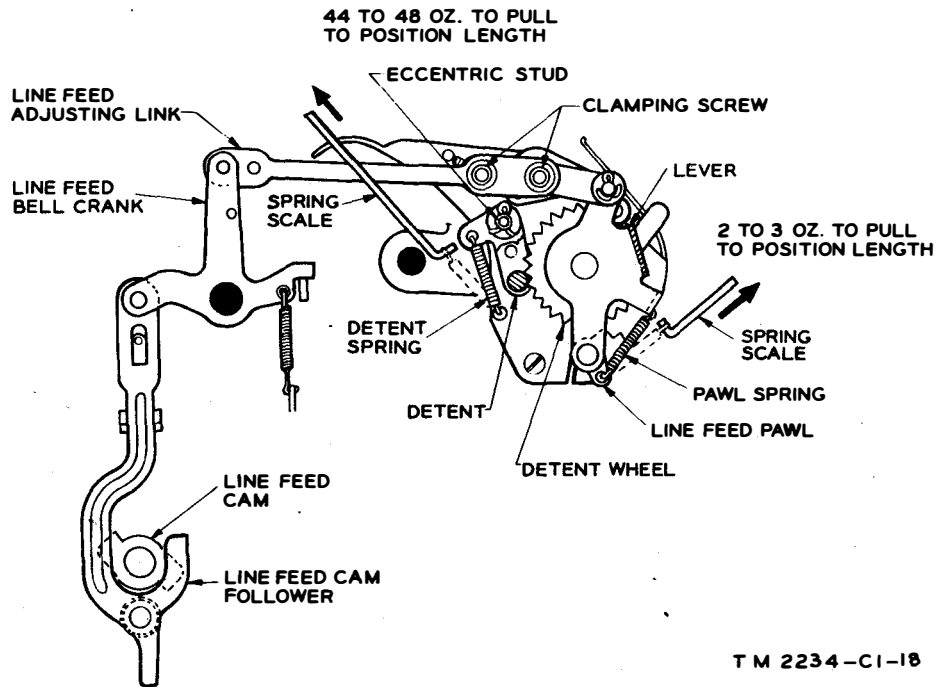

Figure 174. LINE FEED mechanism, side view.

Page 182. Par. 245. Add the following to subparagraph a: with the adjustable pawl stop in the position shown in A, figure 174.1 and two line spaces when it is in the position shown in B, figure 174.1.

Page 182. Fig. 174. Insert figure 174.1 after 174.

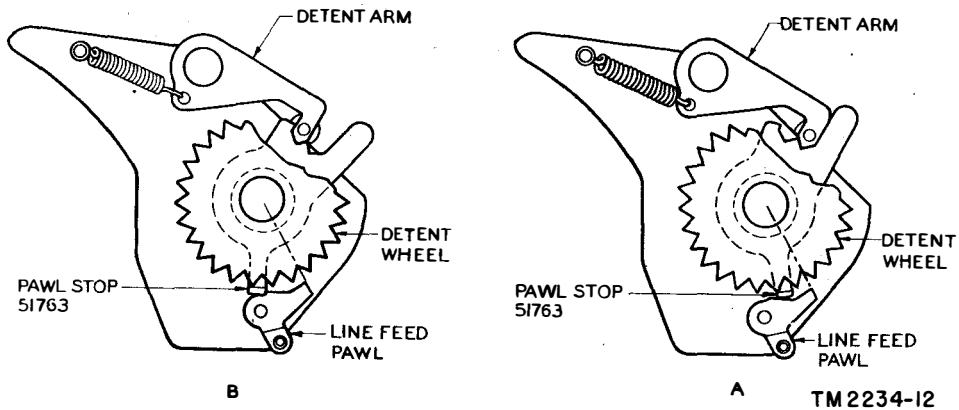

Figure 174.1. LINE FEED mechanism settings for Teletypewriter TT-4A/TG.

Page 183. Par. 247. Make the following changes in paragraph 247:

In subparagraph *a* (1), line 1, change ".040-inch" to read: .035- to .045-inch.

In subparagraph *a* (2), line 1, change ".003- to .005-inch" to read: .005- to .010-inch.

Page 183. Par. 249. Make the following changes in paragraph 249:

In subparagraph *a*, lines 2 and 3, delete the phrase "before (about $\frac{1}{16}$ inch)" and substitute the following: as.

Delete subparagraph *b* and substitute the following:

b. **ADJUSTMENT.** This adjustment should be made after the carriage-feed clutch and carriage-return clutch have been adjusted. Move the carriage to the left against the left margin stop; this should give a margin of $1\frac{1}{32}$ inch. Loosen the locking screws which hold the latch-tripping arm (fig. 176) to the carriage-return driven gear. Disengage the carriage-feed clutch. Rotate the carriage-return gears until the protruding end of the decelerating cam is within $\frac{3}{32}$ to $\frac{1}{8}$ inch from the top edge of the decelerating arm. It may be necessary to disengage the rack from the driven gear to permit sufficient rotation to get the proper adjustment. This can be done by loosening the screws which hold rail 50394A to the frame sufficiently to raise the carriage so the rack disengages the driven gear. When the proper position is reached by the cam the rack and gear should be re-engaged and the screws should be tightened in the rail. Next, slide the latch-tripping arm on the mounting screws against the carriage-return clutch until the carriage-return operating lever is just unlatched. Tighten the locking screws.

Note. It may be necessary to readjust the carriage-feed clutch in accordance with instructions given in paragraph 255 after the above adjustment has been made.

Page 183. Fig. 176. Make the following changes in figure 176:

In figure 176, change ".040 in." to read: .035 to .045 in. and change ".003 to .005 in." to read: .005 to .010.

Add the following after the caption: (See figures 78.1 and 79.1 for carriage-feed and carriage-return blocking means.)

Page 184. Par. 252. In subparagraph *b*, lines 1 and 2, change the words "Loosen the two mounting screws which hold" to read: Remove.

Page 185. Par. 256. In subparagraph *a*, change ".040" to read: .030.

Page 185. Fig. 179. Change "16 to 20 oz" to read: 4 to 6 oz. and change ".040 to .050" to read: .030 to .050.

Page 185. Par. 257. In subparagraph *b*, line 4, change "73" to read: 72.

Page 186. Par. 259. Delete paragraph 259.

Page 186. Figs. 180 and 182. Delete figures 180 and 182.

Page 186. Par. 260. Make the following changes in paragraph 260:

In subparagraph *a*, change "30 to 32" to read: 32 to 40.

In subparagraph *b*, line 3, change "28" to read: 36.

Page 186. Par. 261. Make the following changes in paragraph 261:

In subparagraph *b*, line 2, change "50810A" to read: 51579A.

Change the last sentence of subparagraph *a* to read: Replace cover 51579A.

Page 186. Fig. 181. Delete figure 181 and substitute the following:

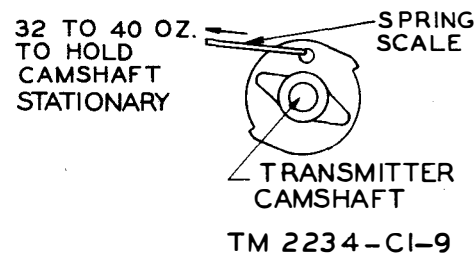

Figure 181. Transmitter-friction-clutch adjustment.

Page 186. Par. 263. In the first line of subparagraph *a*, change ".008 to .010" to read: .006 to .015.

Page 186. Fig. 183. Delete figure 183 and substitute the following:

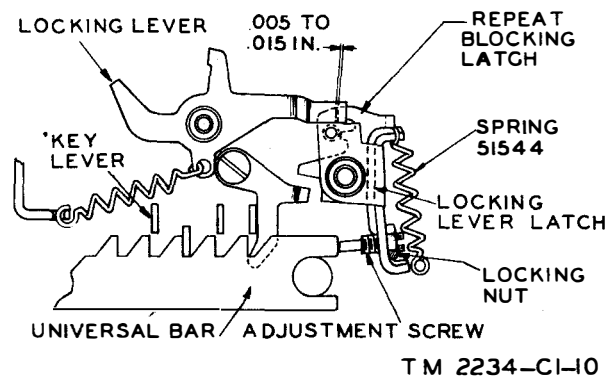

Figure 183. Universal-bar adjustment.

Page 187. Par. 264. Add the following at the end of subparagraph *b*: After adjusting the springs, adjust the eccentric stops to clear the springs by .015 in.

Page 190. Fig. 185. Delete figure 185 and substitute the following: (See end of supplement.)

Page 192. App. II. Make the following changes in the appendix: Add the following to the "Note": In most instances parts for Teletypewriters TT-4/TG and TT-4A/TG are identical. Parts *not used* in Teletypewriter TT-4A/TG are indicated below by deletions. Parts *used only* in Teletypewriter TT-4A/TG are added to the table.

Pages 193 through 198. "Selector Group". Make the following changes in the table:

Delete parts indicated by the following part numbers in the column headed "*Ref symbol*":
50520, 50521, 50522, 50523, 50524, 50898,
50890A, 50893A, 50607A, 50486A, 50498A,
50150, and 50153.

Add to the table the following parts which are used only in Teletypewriter TT-4A/TG:

Selector Group, Additional Parts, Teletypewriter TT-4A/TG

Ref. symbol	Name of part and description	Function of part	Signal Corps stock No.
51631	BAR, code: fan shape, approx 2 $\frac{3}{4}$ " wd x 2 $\frac{5}{8}$ " h x .069" thk; single .500 dia mtg hole; stamped with numeral 1.	Controls selection.	4TK51631
51632	BAR, code: fan shape, approx 2 $\frac{3}{4}$ " wd x 2 $\frac{5}{8}$ " h x .069" thk; single .500" dia mtg hole; stamped with numeral 2.	Controls selection.	4TK51632
51633	BAR, code: fan shape, approx 2 $\frac{3}{4}$ " wd x 2 $\frac{5}{8}$ " h .042" thk; single .500" dia mtg hole; stamped with numeral 3.	Controls selection.	4TK51633
51634	BAR, code: fan shape, approx 2 $\frac{3}{4}$ " wd x 2 $\frac{5}{8}$ " h x .069" thk; single .500" dia mtg hole; stamped with numeral 4.	Controls selection.	4TK51634
51635	BAR, code: fan shape, approx 2 $\frac{3}{4}$ " wd x 2 $\frac{5}{8}$ " h x .096" thk; single .500" dia mtg hole; stamped with numeral 5.	Controls selection.	4TK51635
51609	COLLAR, locking: nylon; for armature and range dials.	Clamps dials.	4TK51609
51395	COLLAR: spacing cylindrical; 1" OD, .502" hole, .134" thk o/a.	Code ring spacer.	4TK51395
51396	COLLAR: spacing, cylindrical; 1" OD, .502" hole, .029" thk o/a.	Code ring spacer.	4TK51396
51397	COLLAR: shaft, cylindrical; 1" OD, .501" hole; .3125" thk o/a.	Code ring take-up.	4TK51397
51416	COLLAR: shaft, cylindrical; $\frac{7}{16}$ " OD, .315" hole, .232" thk o/a.	Selector lever spacer.	4TK51416
51605A	DIAL: nylon graduated circular type; dial divided into 26 equal spaces numbered 0 to 120.	Armature spring adjustment.	51605A
50607A	DIAL: nylon graduated circular type: dial divided into 26 equal spaces numbered 0 to 120.	Part of rangefinder equipment.	50607A
51399A	PLATE, guide: fan shape; approx 3 $\frac{1}{2}$ " wd x 2 $\frac{3}{8}$ " h x 1 $\frac{3}{4}$ " thk.	For stop lever mounting.	4TK51399A
51636A	PLATE, guide: fan shape; approx 2.235" lg x 4" wd x 2 $\frac{5}{16}$ " h o/a.	For stop lever mounting.	4TK51636A
51415	STUD: carbon drill rod; 1.843" lg x $\frac{5}{16}$ " hex. o/a; one end threaded $\frac{3}{16}$ " lg w/6-40 NF-2 thd.	Selector levers pivot.	4TK51415

Page 203. In the "Carriage Subassembly" group, delete the part indicated by the part number 50434 in the column headed "*Ref symbol*".

Page 205 to page 209. "Keyboard-Transmitter Group". Make the following changes in the table:

Delete parts indicated by the following parts numbers in the column headed "*Ref symbol*":
50849A, 50840, 50933, 50623, 50620, 50624,
50625, 50618, 50619, 51069, 50633A, 50767A,
50639, 50931, 50932, 50638, 50640A, 50943,
50945, 50946, 50616, 50617, 50747, 50748,
50819, 50831, 50838, and 50839.

Add to the table the following parts which are used only in Teletypewriter TT-4A/TG:

Keyboard-Transmitter Group, Additional Parts, Teletypewriter TT-4A/TG

Ref. symbol	Name of part and description	Function of part	Signal Corps stock No.
51557	BEARING, pivot: bronze; hex. shape, approx $\frac{7}{16}$ " wd, $\frac{1}{8}$ " thk; eccentric.	Locking-lever pivot.	4TK51557
51545A	CAMSHAFT, step cone shape:	Transmitter.	4TK51545A
51555	COLLAR, spacing: $\frac{7}{16}$ " OD x .037" thk o/a.	For locking bail.	4TK51555
51599	COLLAR, spacer: carbon drill rod; .620" OD, .714" lg.	Ball bearing spacer on transmitter shaft.	4TK51599
51558	GUIDE, lever: rectangular shape; $1\frac{1}{2}$ " lg x $1\frac{1}{2}$ " wd x .062" thk o/a.	For selector levers.	4TK51558
51567	LATCH, lever: key shape; $2\frac{3}{16}$ " lg x $\frac{3}{4}$ " wd x .062" thk.	Sensing lever latch	4TK51567
51594	LATCH, lever: pear shape: approx 1" lg x $\frac{9}{32}$ " wd x .050" thk o/a.	Stop impulse.	4TK51594
51569	LATCH, lever: U shape; approx $\frac{5}{8}$ " wd x $1\frac{3}{16}$ " h x $\frac{5}{8}$ " thk o/a.	Blocks signal repetition.	4TK51569
51570A	LATCH, lever: irregular; bent flat stock; approx $1\frac{3}{8}$ " lg x $1\frac{3}{16}$ " wd x $\frac{7}{8}$ " thk.	Transmitter release.	4TK51570A
51549A	LEVER: spring steel, hardened; L shape, approx $2\frac{1}{16}$ " lg x $1\frac{3}{16}$ " wd x $1\frac{1}{16}$ " thk o/a.	Locking.	4TK51549A
51573A	LEVER SET: c/o 5 identical parts; spring steel, hardened; L shape, approx $3\frac{7}{32}$ " lg x $\frac{7}{8}$ " wd x .046" thk o/a.	Code sensing.	4TK51573A
51598	LEVER SET: irregular key shape; c/o 6 levers machined together; each approx 2" lg x $\frac{3}{4}$ " wd x .062" thk o/a.	Selector levers.	4TK51598
51595A	MOUNTING: rectangular; approx $2\frac{1}{16}$ " lg x $\frac{7}{8}$ " wd x $1\frac{1}{32}$ " h o/a.	For contact holders.	4TK51595A
51581	PIVOT: $1\frac{5}{8}$ " lg x $\frac{7}{16}$ dia o/a.	For sending contact.	4TK51581
51563	POST, drill rod: hardened, 1.725" lg x $\frac{1}{2}$ " hex. o/a; one end threaded 7.32" lg w/#6-40 thd, other end threaded $\frac{1}{4}$ " lg w/#8-32 thd.	Camshaft stop lever pivot.	4TK51563
51575	SPRING: helical extension type; .012" dia; tinned music wire; $\frac{3}{4}$ " free lgth, $\frac{5}{32}$ " OD, approx 42 turns.	For locking lever.	4TK51575

Keyboard-Transmitter Group, Additional Parts, Teletypewriter TT-4A/TG (contd.)

Ref. symbol	Name of part and description	Function of part	Signal Corps stock No.
51544	SPRING: helical extension type; .012" dia tinned music wire; 7/8" free lgth, 5/32" OD, approx 50 turns; hook term. at one end, eye term. at other, crossed.	For clutch latch lever.	4TK51544
51548	SPRING: helical extension type; .015" dia tinned music wire; 7/16" free lgth, 1/8" OD, approx 16 turns; parallel hook term. at both ends.	For sending contact.	4TK51548
51574	SPRING: helical extension type; .012" dia tinned music wire; 5/8" free lgth, 5/32" OD, approx 31 turns; parallel hook term. at both ends.	For locking lever.	4TK51574
51568	SCREW: 15/32" lg x 5/16" hex. o/a; slot drive threaded 3/16" lg k/#6-40 thd.	Space repeat lever pivot.	4TK51568
51564	STUD: 17/32" lg x 3/16" hex. o/a; one end slotted, 1/4" flat 3/16" from end opposite slot.	Locking-lever pivot.	4TK51564
51561	STUD: drill rod, hardened; 13/4" lg x 1/2" hex. o/a; one end threaded 3/64" lg w/#8-32 thd, other end threaded 7/32" lg w/#6-40 thd.	Selector-lever pivot.	4TK51561
51562	POST: drill rod, hardened; 1.9/32" hex. o/a; one end slotted; 1/4" flat 3/16" from other end.	Sensing-lever pivot.	4TK51562
51560	STUD: copper, aluminum, silicon alloy: 1.333" lg x 1/2" hex. o/a; one end tapped 3/8" d w/#10-32 thd; 6 slots in body.	Code-bar guide.	4TK51560
50552	WASHER, slot: brass; 7/16" OD, .032" thk, .317" hole.	For spacing selector finger.	4TK50552

Page 209 to page 211. "Platen Group". Make the following changes in the table:

Delete parts indicated by the following part numbers in the column headed "*Ref symbol*":
50160, 50170A, 50202A, 50472, 50473, 50240A,
50113, 50168, and 50164.

Add to the table the following parts which are used only in Teletypewriter TT-4A/TG:

Platen Group, Additional Parts, Teletypewriter TT-4A/TG

Ref. symbol	Name of part and description	Function of part	Signal Corps stock No.
51690	KNOB: round, nylon; spring tension, adjustable position.	Used to turn platen.	4TK51690
51756A	GUIDE, paper trough.	Guides paper around platen.	4TK51756A
51756A	GUIDE, paper trough.	Guides paper around platen.	5TK51756A
51693	LINK, connecting: phosphor bronze; $2\frac{3}{8}$ " lg x $\frac{3}{8}$ " wd x $\frac{1}{16}$ " thk o/a.	Shifts platen.	4TK51693
51771	LINK, lever: phosphor bronze; approx $1\frac{1}{2}$ " lg x $\frac{5}{8}$ " wd x $\frac{1}{16}$ " thk.	Part of LINE FEED mechanism.	4TK51771
51687A	SHAFT: round, $13\frac{2}{64}$ " lg x $1\frac{1}{16}$ " wd x $\frac{1}{4}$ " h o/a.	For platen.	4TK51687A
51689	SPRING: flat type; cylindrical shape, slotted for $\frac{3}{32}$ " dia stop pin.	Holds platen knob in position.	4TK51689
51769	STUD: $2\frac{5}{32}$ " lg x $\frac{1}{4}$ " hex. o/a; one end threaded $\frac{3}{16}$ " lg w/#6-40 thd.	Pivot for detent.	4TK51769
51772	WHEEL, detent: brass; 1.250" dia x .343 thk o/a.	To index platen.	4TK51772

Page 212 through page 227. "Function Group".
Make the following changes in the table:

Delete parts indicated by the following part numbers in the column headed "*Ref symbol*":
50754, 50367A, 50505, 50470A, 50258, 51070,
50121A, 50135A, 50824A, 50179, 50508A,
50526, 50527, 50528, 50827.

Add to the table the following parts which are used only in Teletypewriter TT-4A/TG:

Functional Group, Additional Parts, Teletypewriter TT-4A/TG . (contd.)

Ref. symbol	Name of part and description	Function of part	Signal Corps stock No.
51428	BLOCK, guide: aluminum, semicircular shape.	For punch bars.	4TK51428
51612A	CAM ASSEMBLY: c/o cams No. 51614, 51615, 51616: 2 washers No. 50371; .678" lg x 1½" dia o/a.	Function sensing and LINE FEED.	4TK51612A
51668	COLLAR, shaft: cylindrical; 5/8" OD, .2187" hole, .587" wd o/a; 1 radial tapped mtg hole #10-32 NC-3 thd.	Hub for blocking lever.	4TK51668
51685A	CRANK, bell: c/o bell crank No. 51686, hub No. 50468, and 2 studs No. 50469; L shape.	Platen shift bell crank.	4TK51685A
51678	DISK, clutch: friction disk type.	Part of CAR RET clutch.	4TK51678
51671A	DOG, pear shape: approx 7/8" wd x 7/8" h x 9/16" thk.	For positioning blocking lever.	5TK51671A
51643A	DRUM SET, clutch: two-piece jaw-set type.	Part of CAR RET safety clutch.	4TK51643A
51741A	GEAR ASSEMBLY: mounted gear; attached aluminum hub, disk shape.	For CAR RET clutch.	4TK51741A
51682A	LEVER: flat sheet stock w/hub staked near ctr.	CAR RET operating lever.	4TK51682A
51669	LEVER: carbon steel, irregular shape.	Space pawl blocking lever.	4TK51669
51425A	LEVER: c/o lever No. 51426 and stud No. 50159.	Carriage-feed lever.	4TK51425A
51697	NUT, round. stainless steel, shoulder finished square; 1½"-24, NF-3 thd; .509" thk, 1¾" OD.	Part of CAR RET safety clutch.	4TK51697
51676A	PAWL: c/o pawl No. 51677 and stud No. 50267; Y-shaped hook; approx 2" lg x 1/8" wd x 3/8" h o/a.	Carriage-feed pawl.	4TK51676A
51639	SHAFT: stainless steel; .2357" dia one end, 1/32" groove at other end.	CAR RET drive shaft.	4TK51639
51554	SHAFT: stainless steel; single .063" dia hole.	Transmitter drive shaft.	4TK51554
51645	SPRING: helical; .016" tinned music wire; approx 63 turns; 1¼" free lgth x 5/32" OD, hook term. both ends.	Platen return spring.	4TK51645
51670	WASHER, flat: phosphor bronze; round; 1/2" OD, .062" thk.	Retaining lever.	4TK51670

Pages 228 through 234. "Electrical Group". Make the following changes in the table:

Delete parts indicated by the following part numbers in the column headed "*Ref symbol*":
50626A, 20351, 20352, 51040A, 51077A, 51624A,
C5 through C8 and C10 through C12, C1 and
C2, L1 through L6, 50711A, 50810A, 51042,
51056, 51060, 51053A, 51051, 51137A, 51610,
20705, 20707, 20708, 20709, 20710, 20711,
20712, 20721, 20731, 20735, 20736.

Add to the table the following parts which are used only in Teletypewriter TT-4A/TG:

Electrical Group, Additional Parts, Teletypewriter TT-4A/TG

Ref. symbol	Name of part and description	Function of part	Signal Corps stock No.
51582A	ARM, irregular shape; nickle-plated; approx 1 $\frac{3}{8}$ " lg x 1 $\frac{3}{4}$ " wd x 1 $\frac{3}{4}$ " h o/a.	Transmitter contact.	4TK51582A
20360A	BOARD, terminal: bakelite, w/7 solder type term., double end; 6 single end; 2 #5-40 binder head screws each term.	General purpose binding post strip for interconnection of teletypewriter components.	4TK20360A
20359A	BOARD, terminal: bakelite.	General purpose binding post.	4TK20359A
20359A	BOARD, terminal: bakelite, 3 term.	General purpose binding post.	4TK20359A
51653A	CABLE ASSEMBLY, shielded: w/two leads.	Motor power cord.	4TK51653A
51624A	CABLE ASSEMBLY, shielded: w/4 leads.	Connects switchbox to front panel.	4TK51624A
51588A	CONTACT ASSEMBLY, switch: cylindrical shape.	Makes and breaks signal line.	4TK51588A
51610	LEAD, electrical: #27 AWG, single wire.	Terminal connecting lead.	4TK51610
20210	FILTER, Z1: sealed case, approx 2 $\frac{3}{4}$ " lg x 2 $\frac{3}{4}$ " w x 1" h; 4 solder term.	Radio noise filter.	4TK20210
51662A	FILTER, Z2: sealed case, approx 1 $\frac{1}{4}$ " x 1 $\frac{1}{4}$ " x 2 $\frac{1}{2}$ " h.	Transmitter filter system.	4TK51662A

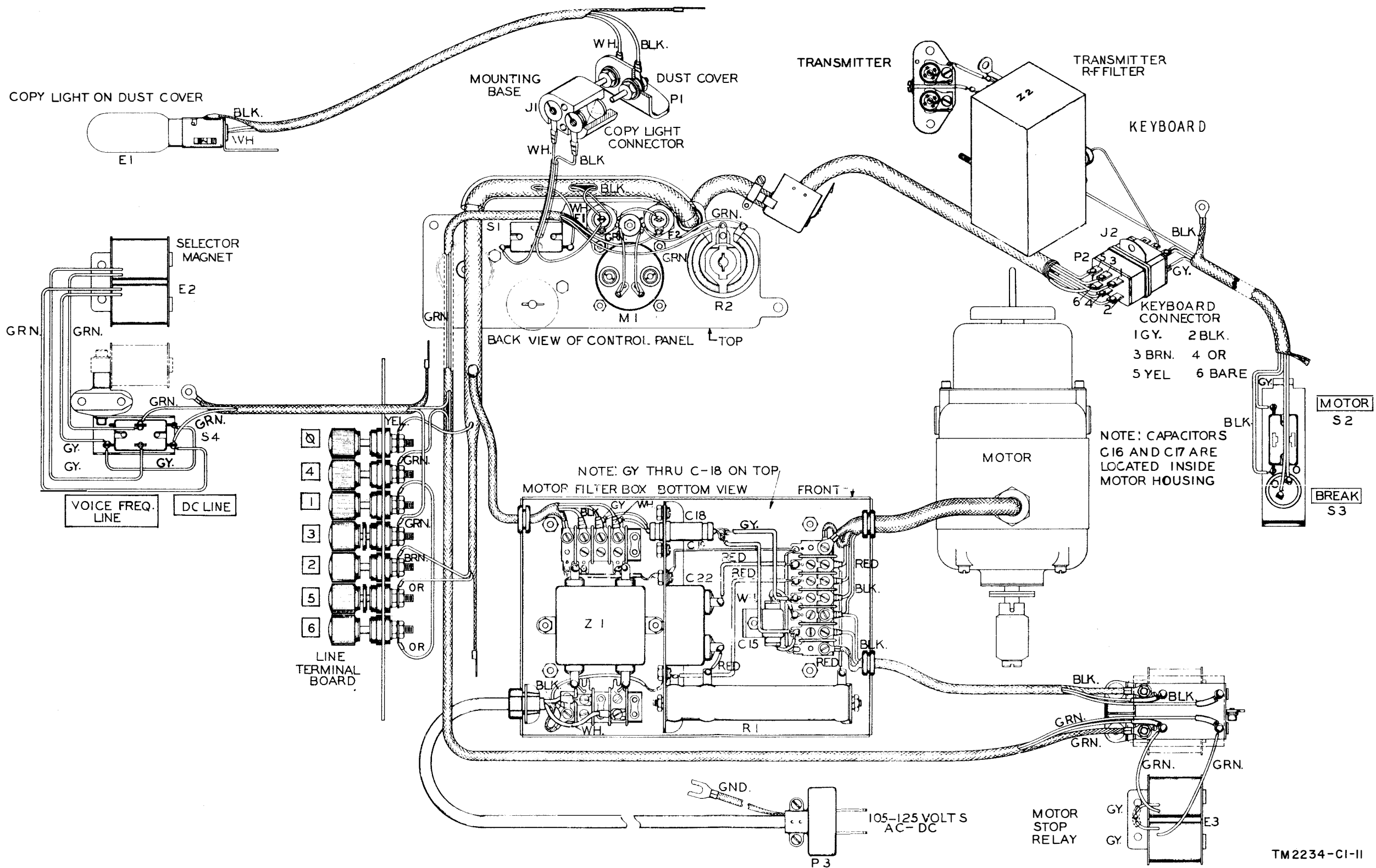

Figure 185. Teletypewriter TT-4A/TC, interconnection diagram.