

TERMINATION PLANS FOR TELETYPEWRITER SUBSCRIBER LINES

1. GENERAL

1.01 This section shows termination plans for teletypewriter subscriber lines. The connection of wave shaping sets is given.

1.02 This section is reissued to include the circuit labels for the 150A1, 150B1 and 150C1 wave shaping sets.

1.03 The following circuit labels are shown:

Fig. 1—150A1 wave shaping set

Fig. 2—150B1 and 150C1 wave shaping sets

Fig. 3—150D1 and 150E1 wave shaping sets

Fig. 4—150F1 wave shaping set

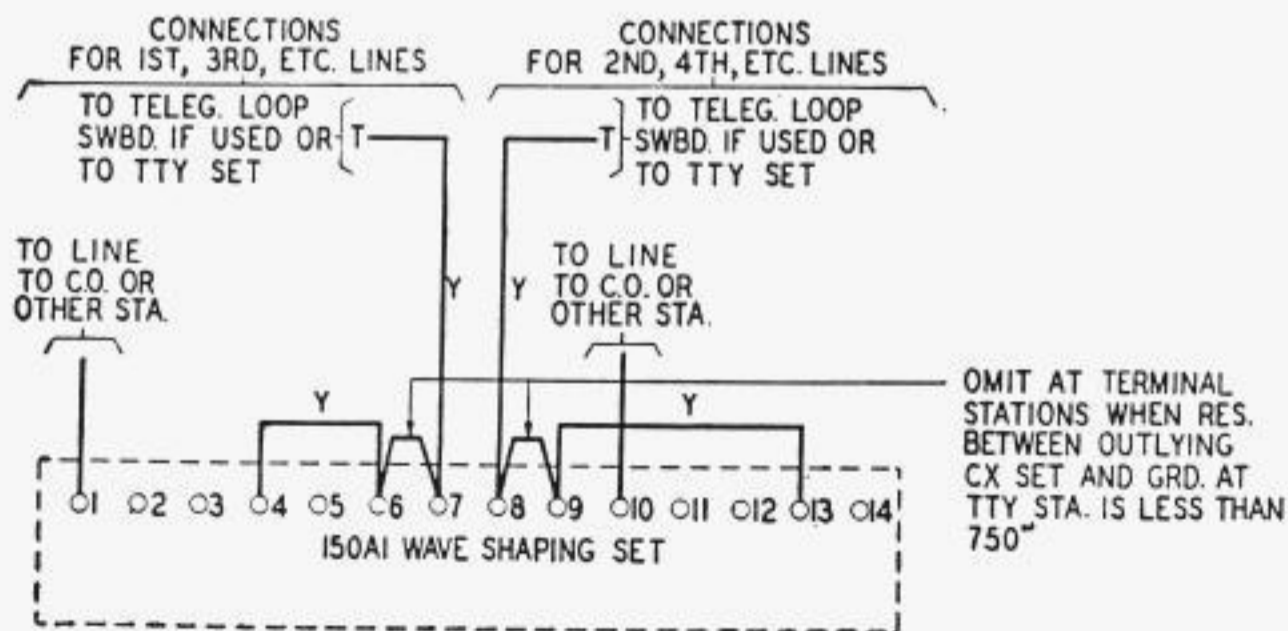

LT1.01 150A1 Wave Shaping Set—Type "A" Polarential Station—CX Open Wire Line

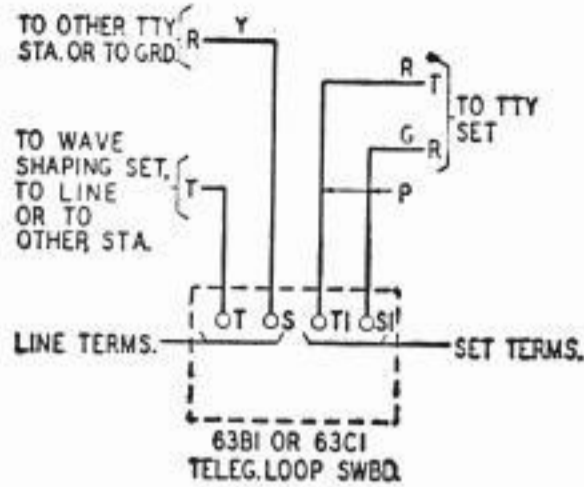

LT1.02 Line and Set Connections to 63B1 or 63C1 Teleg. Loop Swbd. — Polar Station

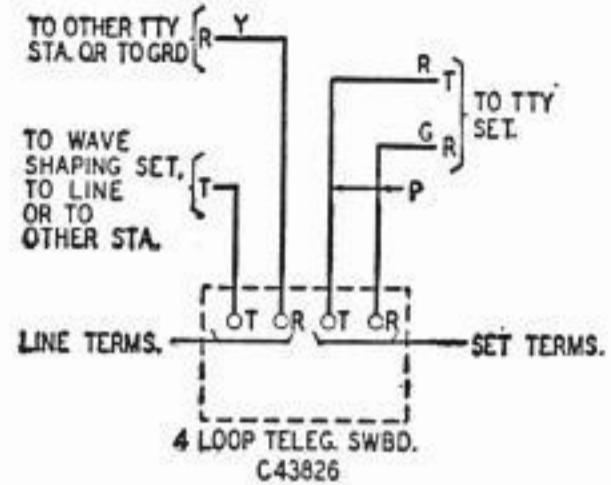

LT1.03 Line and Set Connections to 4 Loop Teleg. Swbd. (C43826) — Polar Station

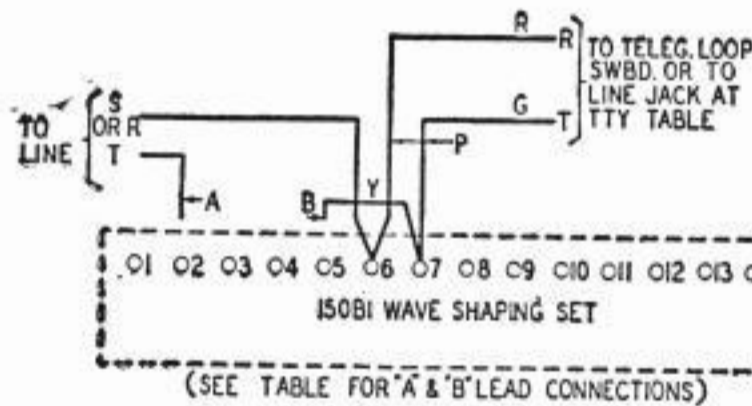

NOTE: PLANS LT104A, LT104B, ETC. ARE LISTED IN THE ORDER OF INCREASING INDUCTANCE FOR BOTH .020 & .060 AMP. LINES.

PLAN	'A' LEAD	'B' LEAD
LT104A	1	2&7
LT104B	2	3&7
LT104C	2	4&7
LT104D	2	5&7
LT104E	1	3&7
LT104F	1	4&7
LT104G	1	5&7

LT1.04 150B1 Wave Shaping Set—TTY Without Spark Killer in Base

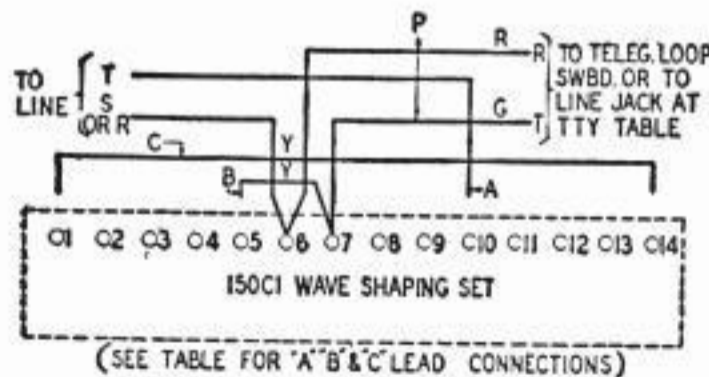

NOTE: PLANS LT105A, LT105B, ETC. ARE LISTED FOR EACH KIND OF LINE IN THE ORDER OF INCREASING INDUCTANCE

.020 AMP. LINE	.060 AMP. LINE	'A' LEAD	'B' LEAD	'C' LEAD
LT105A	LT105A	1	4&7	NOT USED
LT105B	—	10	3&7	2&12
LT105C	LT105C	1	5&7	NOT USED
—	LT105B	10	3&7	2&12
LT105D	LT105D	10	4&7	2&12
LT105E	LT105E	10	5&7	2&12
LT105F	LT105F	10	3&7	2&14
LT105G	LT105G	10	4&7	2&14
LT105H	LT105H	10	5&7	2&14
LT105J	LT105J	10	3&7	1&14
LT105K	LT105K	10	4&7	1&13
LT105L	LT105L	10	4&7	1&14
LT105M	LT105M	10	5&7	1&14

LT1.05 150C1 Wave Shaping Set—TTY Without Spark Killer in Base

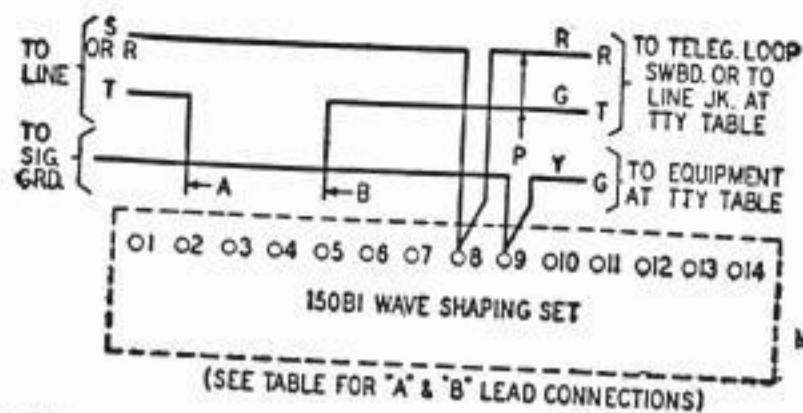

PLAN	"A" LEAD	"B" LEAD
LT1.06 A	1	2
LT1.06 B	2	3
LT1.06 C	2	4
LT1.06 D	2	5
LT1.06 E	1	3
LT1.06 F	1	4
LT1.06 G	1	5

NOTE: PLANS LT1.06A, LT1.06B ETC. ARE LISTED IN THE ORDER OF INCREASING INDUCTANCE FOR BOTH .020 & .060 AMP. LINES.

LT1.06 150B1 Wave Shaping Set—TTY With Spark Killer in Base

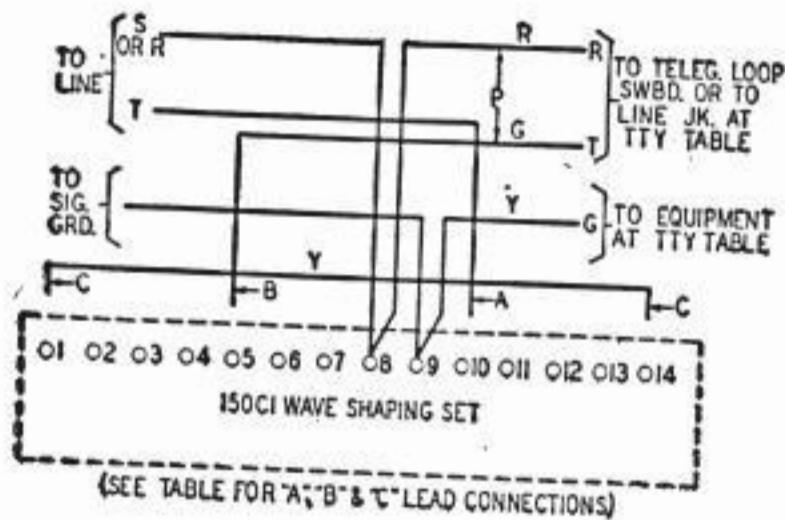

.020AMP. LINE	.060AMP. LINE	"A" LEAD	"B" LEAD	"C" LEAD
LT1.07A	LT1.07A	1	4	NOT USED
LT1.07B	—	10	3	2 & 12
LT1.07C	LT1.07C	1	5	NOT USED
—	LT1.07B	10	3	2 & 12
LT1.07D	LT1.07D	10	4	2 & 12
LT1.07E	LT1.07E	10	5	2 & 12
LT1.07F	LT1.07F	10	3	2 & 14
LT1.07G	LT1.07G	10	4	2 & 14
LT1.07H	LT1.07H	10	5	2 & 14
LT1.07J	LT1.07J	10	3	1 & 14
LT1.07K	LT1.07K	10	4	1 & 13
LT1.07L	LT1.07L	10	4	1 & 14
LT1.07M	LT1.07M	10	5	1 & 14

NOTE: PLANS LT1.07A, LT1.07B, ETC. ARE LISTED FOR EACH KIND OF LINE IN THE ORDER OF INCREASING INDUCTANCE.

LT1.07 150C1 Wave Shaping Set—TTY With Spark Killer in Base

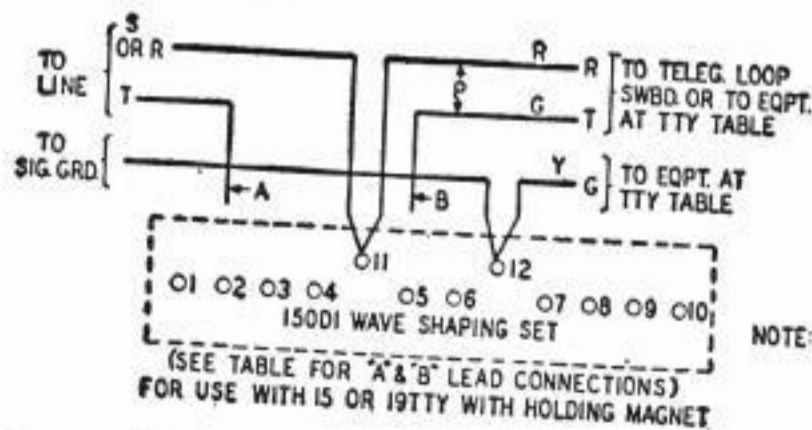

PLAN	"A" LEAD	"B" LEAD
LT1.08 A	1	2
LT1.08 B	2	3
LT1.08 C	2	4
LT1.08 D	2	5
LT1.08 E	1	3
LT1.08 F	1	4
LT1.08 G	1	5

NOTE: PLANS LT1.08A, LT1.08B, ETC. ARE LISTED IN THE ORDER OF INCREASING INDUCTANCE FOR BOTH .020 & .060 AMP. LINES.

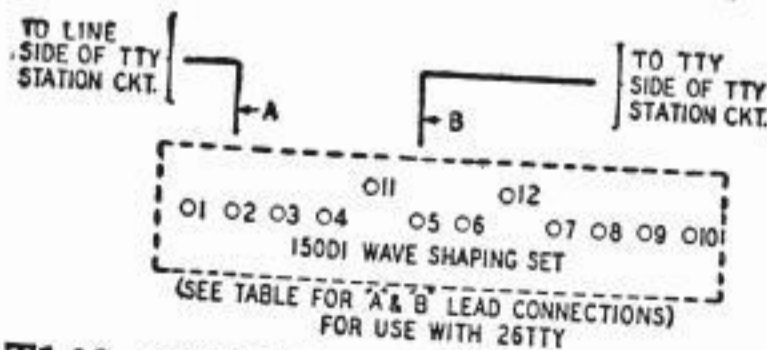

LT1.08 150D1 Wave Shaping Set—TTY With Spark Killer in Base

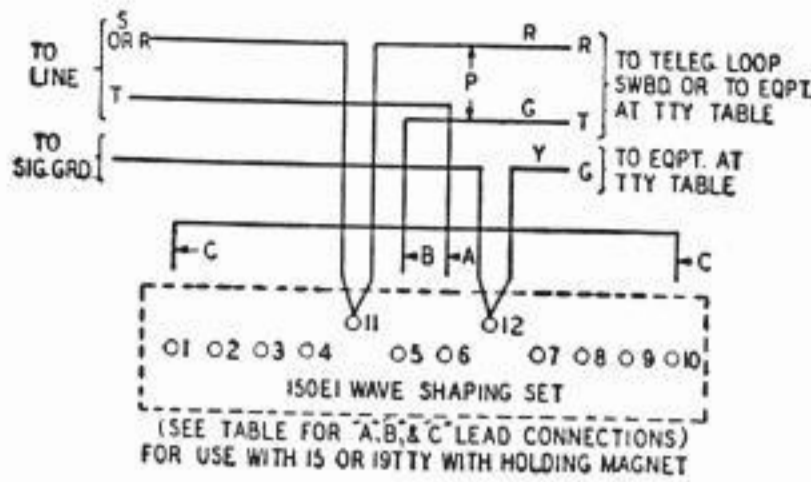

020AMP LINE	060AMP LINE	A LEAD	B LEAD	C LEAD
LT1.09A	LT1.09A	1	4	NOT USED
LT1.09B	---	6	3	2 & 8
LT1.09C	LT1.09C	1	5	NOT USED
---	LT1.09B	6	3	2 & 8
LT1.09D	LT1.09D	6	4	2 & 8
LT1.09E	LT1.09E	6	5	2 & 8
LT1.09F	LT1.09F	6	3	2 & 10
LT1.09G	LT1.09G	6	4	2 & 10
LT1.09H	LT1.09H	6	5	2 & 10
LT1.09J	LT1.09J	6	3	1 & 10
LT1.09K	LT1.09K	6	4	1 & 9
LT1.09L	LT1.09L	6	4	1 & 10
LT1.09M	LT1.09M	6	5	1 & 10

NOTE PLANS LT1.09A, LT1.09B, ETC. ARE LISTED FOR EACH KIND OF LINE IN THE ORDER OF INCREASING INDUCTANCE.

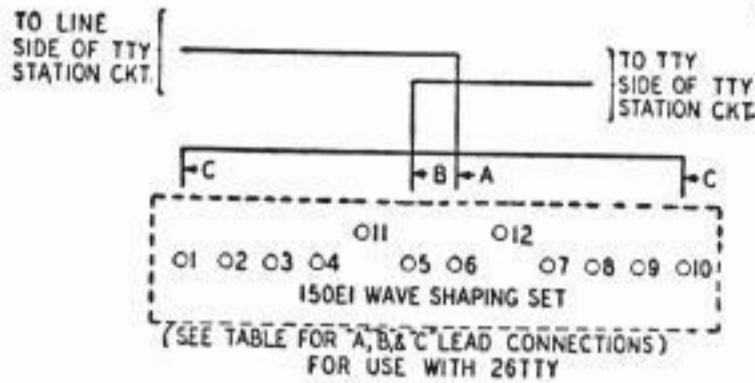

LT1.09 150E1 Wave Shaping Set—TTY With Spark Killer in Base

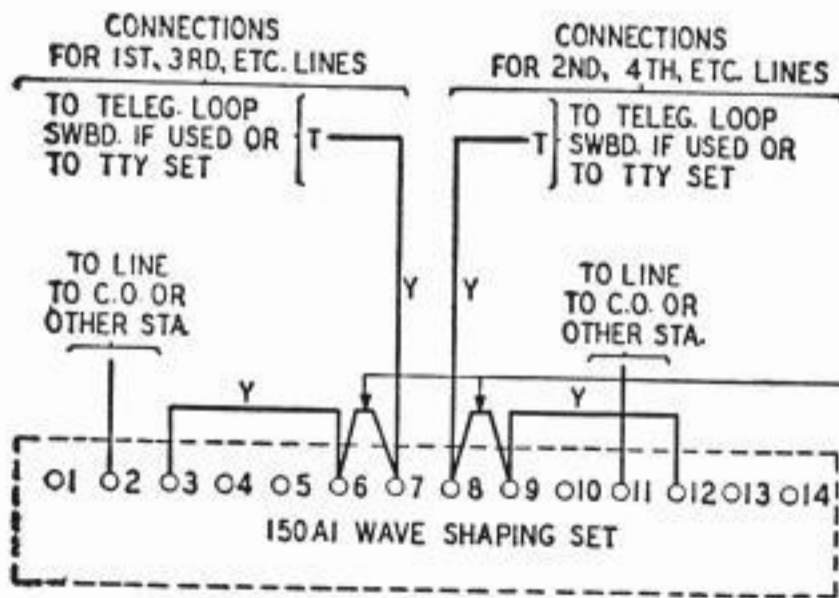

LT1.10 150A1 Wave Shaping Set—Type "A" Polarential Station—SX or SX-PH Cable Lines

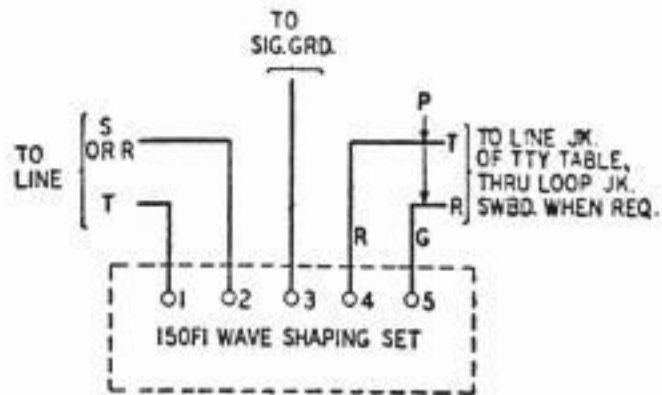

LT1.11 150F1 Wave Shaping Set

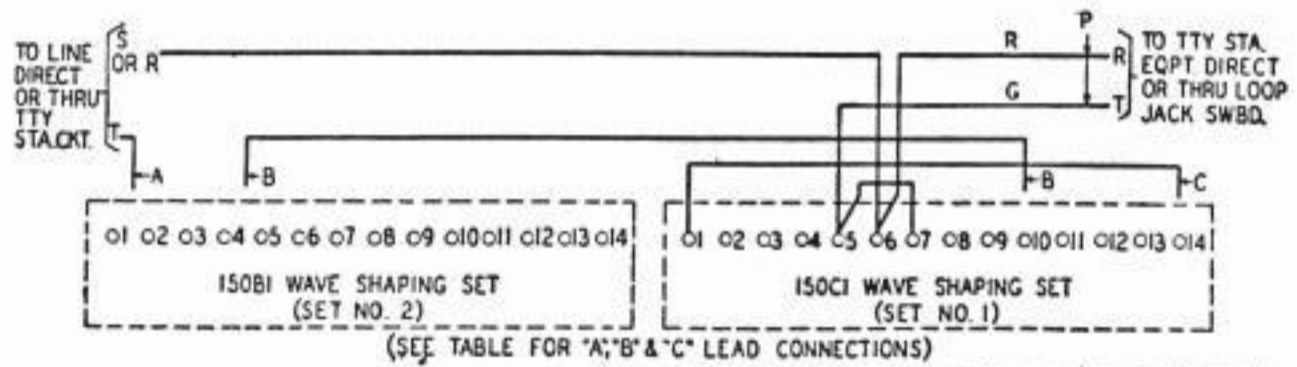

(SEE TABLE FOR "A," "B" & "C" LEAD CONNECTIONS)

PLAN	"A" LEAD		"B" LEAD		"C" LEAD
	SET NO. 1	SET NO. 2	SET NO. 1	SET NO. 2	SET NO. 1
LT1.12A	10	-	-	-	1 & 13
LT1.12B	10	-	-	-	1 & 14
LT1.12C	-	1	10	2	1 & 14
LT1.12D	-	2	10	3	1 & 14
LT1.12E	-	2	10	4	1 & 14
LT1.12F	-	2	10	5	1 & 14
LT1.12G	-	1	10	3	1 & 14
LT1.12H	-	1	10	4	1 & 14
LT1.12J	-	1	10	5	1 & 14

NOTE:
PLANS LT1.12A, LT1.12B, ETC. ARE LISTED IN THE ORDER OF INCREASING INDUCTANCE FOR BOTH .020 & .060 AMP. LINES.

LT1.12 150B1 and 150C1 Wave Shaping Sets—TTY Without Spark Killer in Base

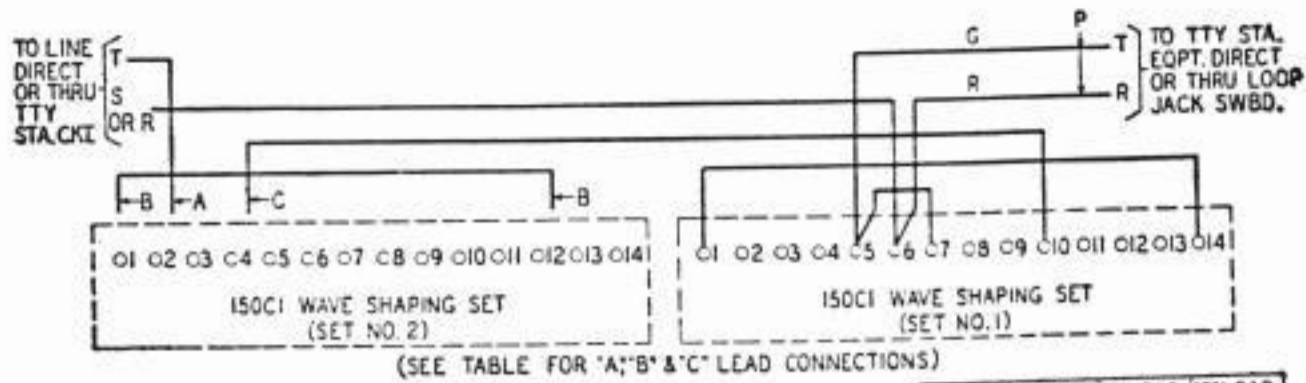

(SEE TABLE FOR 'A', 'B' & 'C' LEAD CONNECTIONS)

PLAN	'A' LEAD SET NO.2	'B' LEAD SET NO.2	'C' LEAD SET NO.2
LT113A	1	-	4
LT113B	1	-	5
LT113C	10	1 & 11	5
LT113D	11	1 & 12	5
LT113E	11	1 & 13	5
LT113F	11	1 & 14	5
LT113G	10	1 & 12	5
LT113H	10	1 & 13	5
LT113J	10	1 & 14	5

NOTE:
PLANS LT113A, LT113B, ETC ARE LISTED IN THE ORDER OF INCREASING INDUCTANCE FOR BOTH .020 & .060 AMP. LINES.

LT1.13 Two 150C1 Wave Shaping Sets in Series—TTY Without Spark Killer in Base

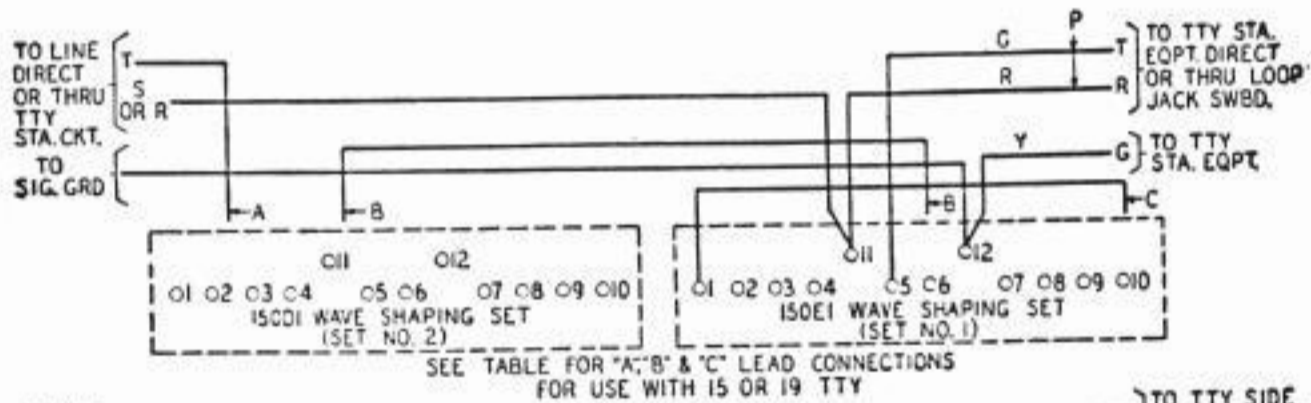

SEE TABLE FOR 'A', 'B' & 'C' LEAD CONNECTIONS FOR USE WITH 15 OR 19 TTY

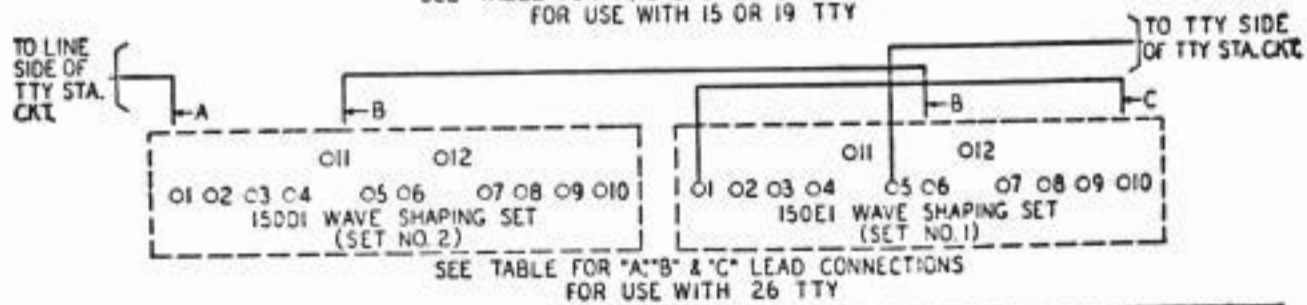

SEE TABLE FOR 'A', 'B' & 'C' LEAD CONNECTIONS FOR USE WITH 26 TTY

PLAN	'A' LEAD		'B' LEAD		'C' LEAD
	SET NO.1	SET NO.2	SET NO.1	SET NO.2	SET NO.1
LT1.14A	6	-	-	-	1 & 9
LT1.14B	6	-	-	-	1 & 10
LT1.14C	-	1	6	2	1 & 10
LT1.14D	-	2	6	3	1 & 10
LT1.14E	-	2	6	4	1 & 10
LT1.14F	-	2	6	5	1 & 10
LT1.14G	-	1	6	3	1 & 10
LT1.14H	-	1	6	4	1 & 10
LT1.14J	-	1	6	5	1 & 10

NOTE:
PLANS LT1.14A, LT1.14B, ETC. ARE LISTED IN THE ORDER OF INCREASING INDUCTANCE FOR BOTH .020 & .060 AMP. LINES.

LT1.14 150D1 and 150E1 Wave Shaping Sets—TTY With Spark Killer in Base

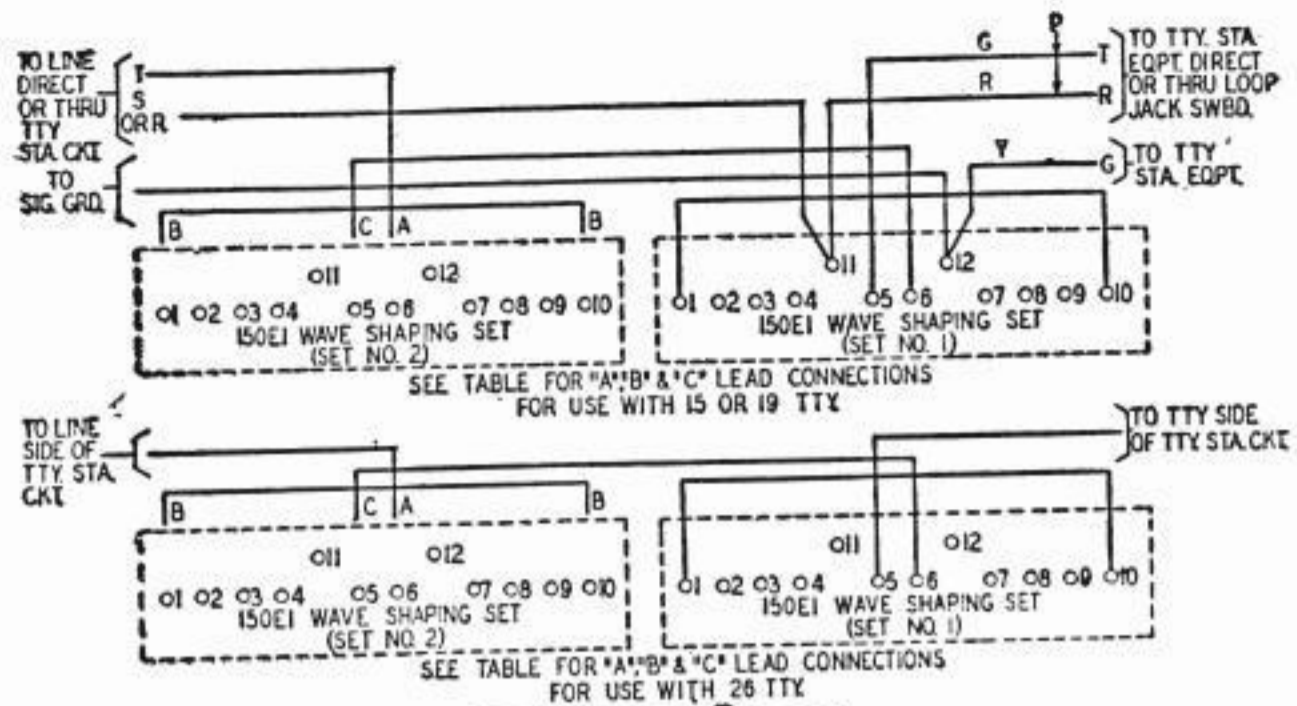

LT PLAN	"A" LEAD SET NO. 2	"B" LEAD SET NO. 2	"C" LEAD SET NO. 2
LT1.15A	1	—	4
LT1.15B	1	—	5
LT1.15C	6	1 & 7	5
LT1.15D	7	1 & 8	5
LT1.15E	7	1 & 9	5
LT1.15F	7	1 & 10	5
LT1.15G	8	1 & 8	5
LT1.15H	6	1 & 9	5
LT1.15J	6	1 & 10	5

LT1.15 Two 150E1 Wave Shaping Sets—TTY With Spark Killer in Base

NOTES:

1. WIRES NOT OTHERWISE SPECIFIED ARE BLACK 22 TYPE "C"
2. LEADS FROM APPARATUS ARE RUN AT RIGHT ANGLES FROM THE APPARATUS TERMINAL TO THE PLANE OF THE CONN. BLK. AND THEN TO THEIR RESPECTIVE CONN. BLK. TERMINALS IN AS SHORT A MANNER AS POSSIBLE.

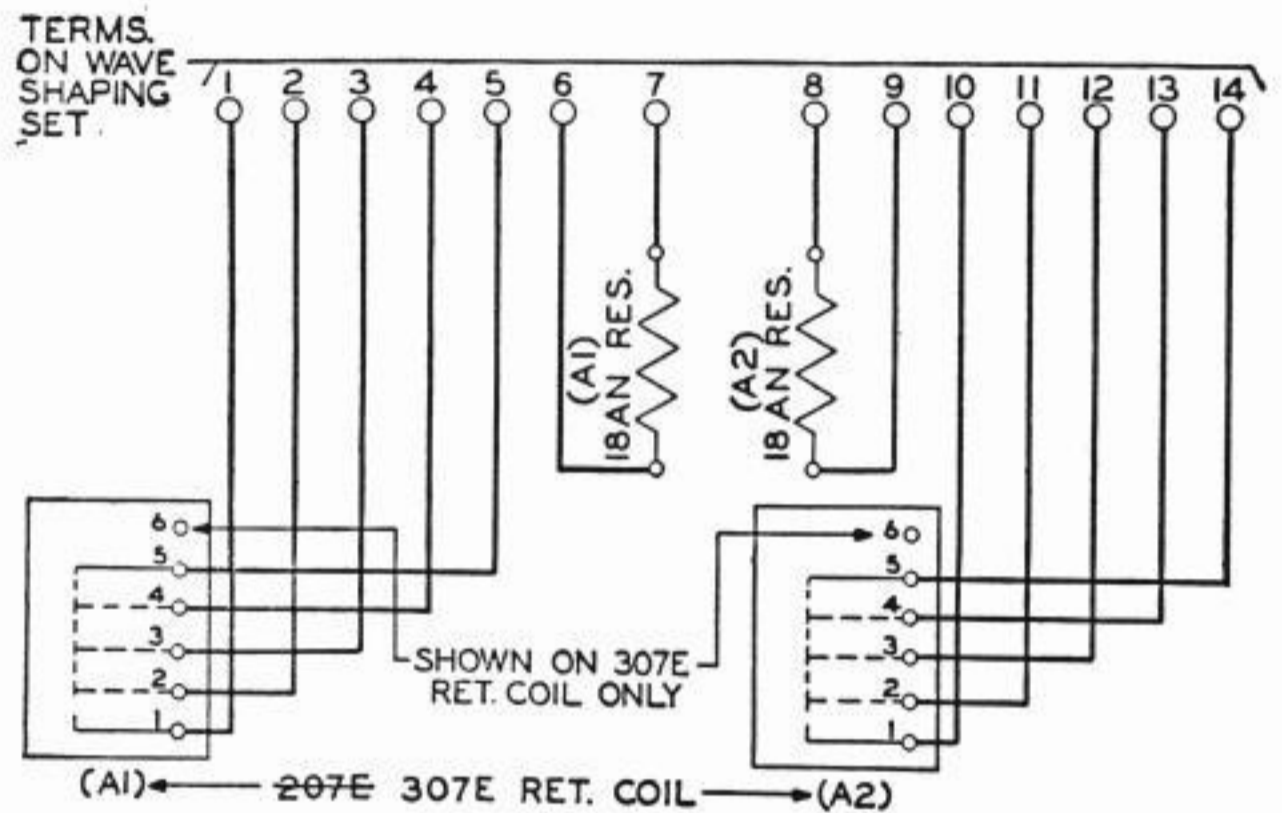

FOR REFERENCE SEE:
SD-70071-01 POLARENTIAL TELETYPEWRITER
STATION CKT.

WIRING OF CIRCUITS
Circuit Label
150A1 Wave Shaping Set

Fig. 1

NOTES:

1. WIRES NOT OTHERWISE SPECIFIED ARE BLACK 22 TYPE "C"
2. LEADS FROM APPARATUS ARE RUN AT RIGHT ANGLES FROM THE APPARATUS TERMINAL TO THE PLANE OF THE CONN. BLK. AND THEN TO THEIR RESPECTIVE CONN. BLK. TERMINALS IN AS SHORT A MANNER AS POSSIBLE.

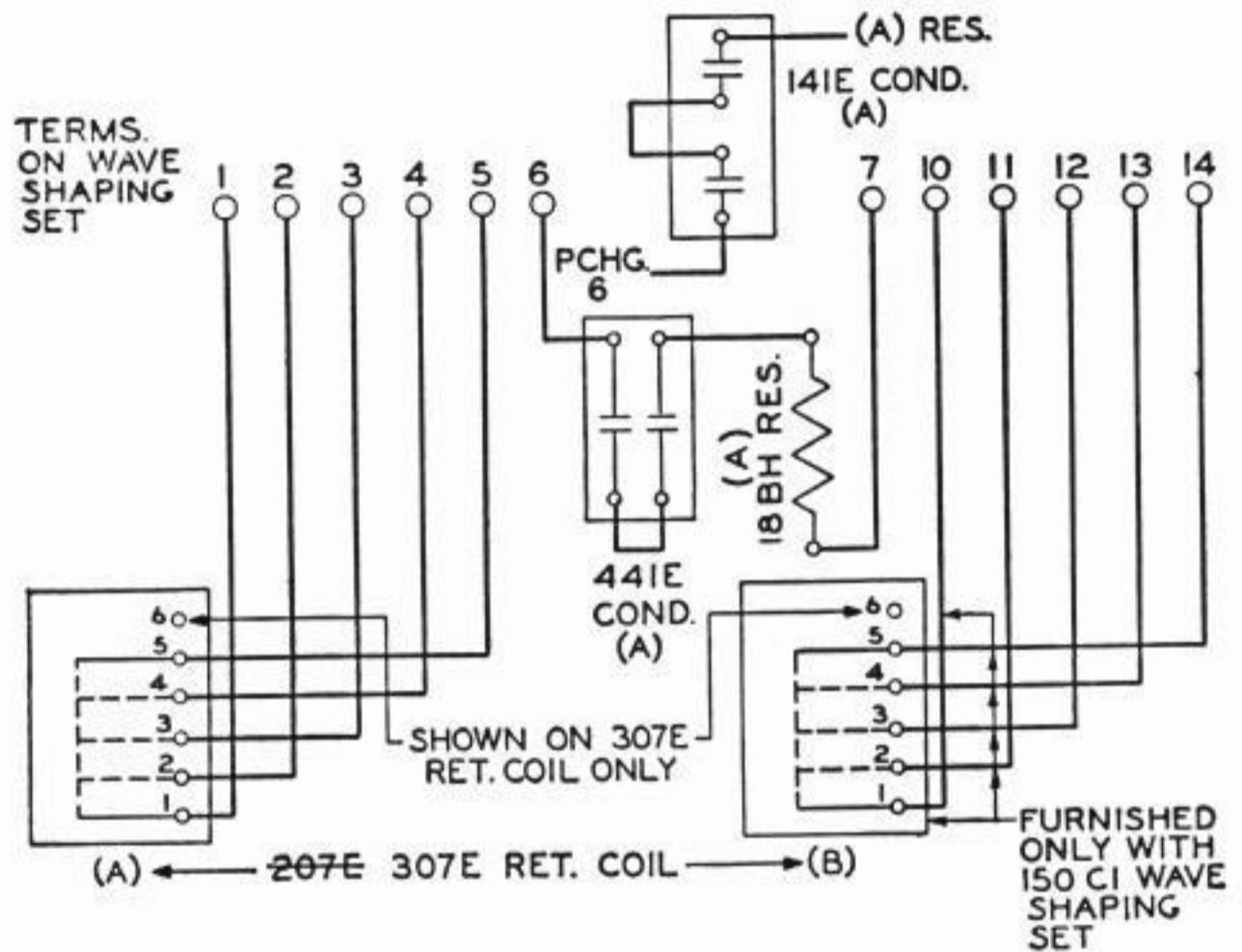

FOR REFERENCE SEE:
SD-70082-01 WAVE SHAPING SET CIRCUIT FOR
TELETYPEWRITER SERVICE.

WIRING OF CIRCUITS
Circuit Label
150B1 and 150C1 Wave Shaping Sets

Fig. 2

NOTES:

1. WIRES NOT OTHERWISE SPECIFIED ARE BLACK
22 TYPE "C"
2. ALL LEADS FROM COILS TO TERMINALS ARE RUN
DIRECT AND ARE THE SAME LENGTH WITH THE
UNSKINNED PORTION OF THE LEAD MEASURING 3"

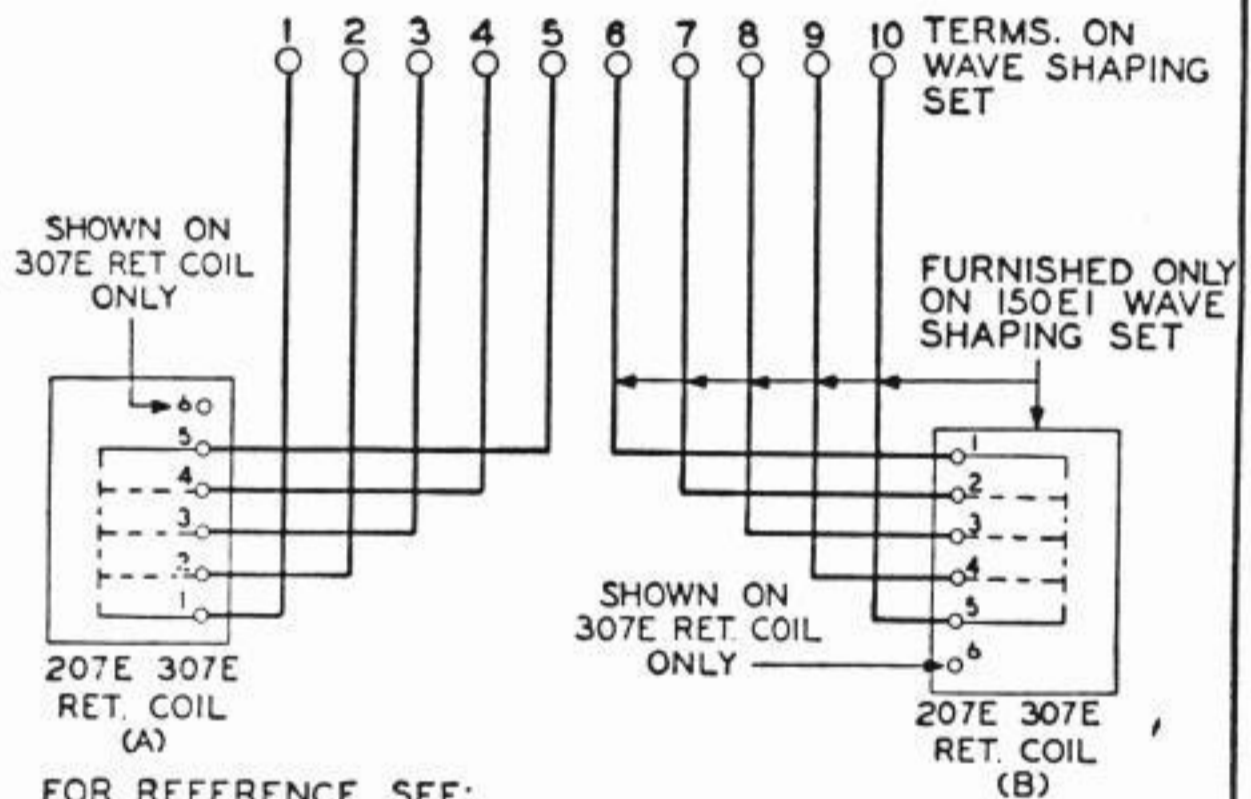

FOR REFERENCE SEE:
SD-70082-01 WAVE SHAPING SET CIRCUIT FOR
TELETYPEWRITER SERVICE.

WIRING OF CIRCUITS
CIRCUIT LABEL
150DI & 150EI WAVE SHAPING SETS

Fig. 3

NOTES:

1. WIRES NOT OTHERWISE SPECIFIED ARE BLACK 22 TYPE "C"
2. LEADS FROM APPARATUS ARE RUN PARALLEL OR PERPENDICULAR TO THE EDGES OF THE MOUNTING BRACKETS OR T.S. AND IN THE SHORTEST POSSIBLE MANNER CONSISTENT WITH THESE REQUIREMENTS.

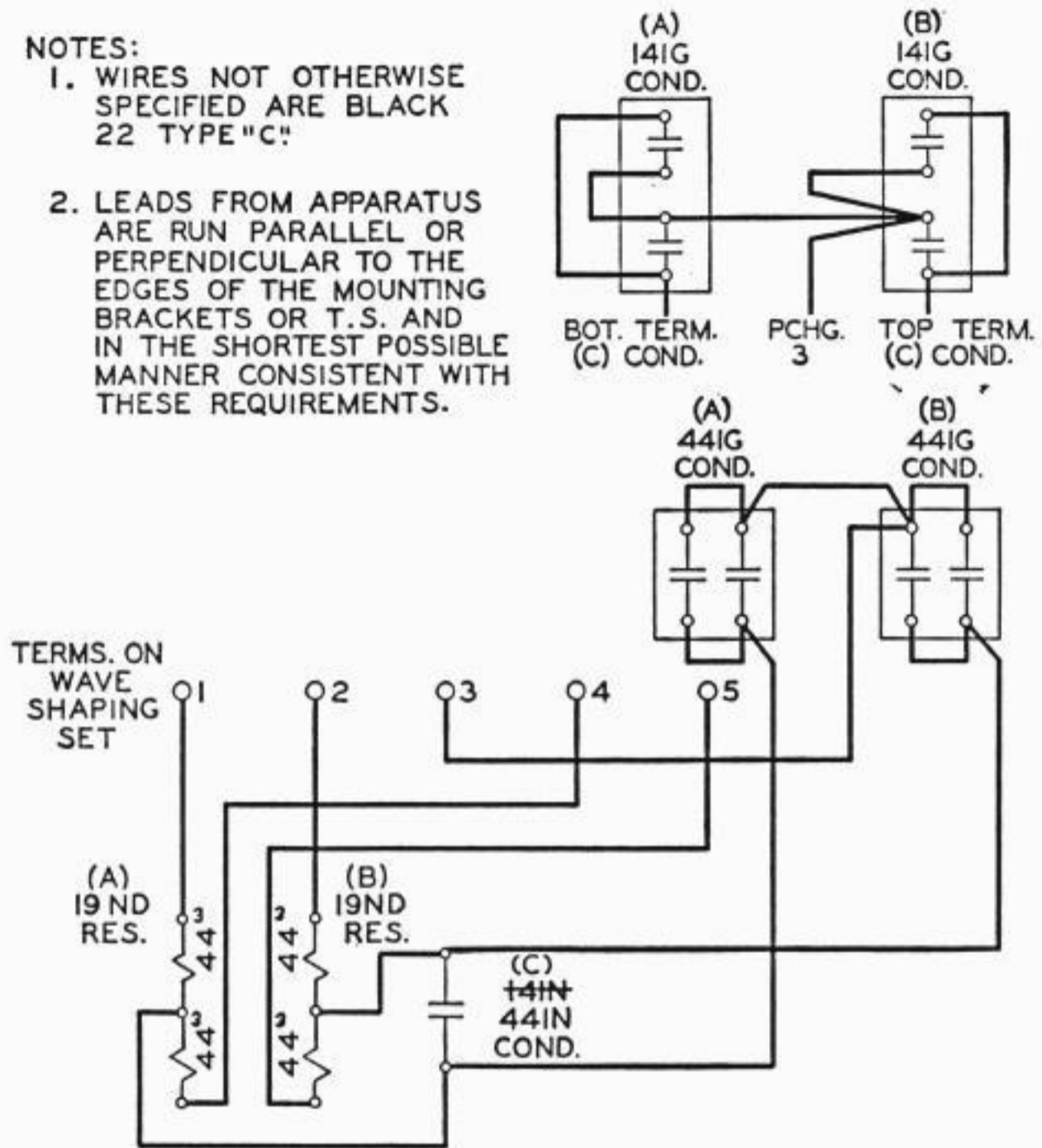

FOR REFERENCE SEE:
SD-70082-01, WAVE SHAPING SET CIRCUIT FOR
TELETYPEWRITER SERVICE.

WIRING OF CIRCUITS
Circuit Label
150F1 Wave Shaping Set

Fig. 4