

BELL SYSTEM PRACTICES
Teletypewriter Stations

SECTION P33.012
Issue 3, October, 1957
AT&TCo Standard

CAM-OPERATED DISTRIBUTOR REQUIREMENTS AND PROCEDURES

Table of Contents	Paragraph
1. General	1.01-1.02
2. Special Tools	2.01
3. Lubrication	3.01
Lubrication—General	P30.011
4. Requirements and Procedures	
Armature spring	4.07
Camsleeve end play	4.01
Cleaning	P30.010
Clutch spring	4.02
Clutch-teeth clearance	4.05
Detent eccentric	4.03
Detent-lever spring	4.04
Front timing-contact adjustment	4.12
General requirements	P30.012
Long transmitting-contact spring	4.10
Motor pinion	4.14
Motor units and governors	P32.004
Rear timing-contact adjustment	4.13
Spring stiffeners	4.11
Short transmitting-contact spring	4.09
Special tools	2.01
Teletypewriter tools	P30.301
Transmitting-contact gap	4.08
Throwout-lever clearance	4.06

1. GENERAL

1.01 This section contains the apparatus requirements and adjusting procedures for the following cam-operated distributors:

FD200AB/JF 100 speed For AMA accounting centers

FD200AB/JG 75 speed For automatic line insulation testing

1.02 This section is reissued to bring the requirements up to date. Changes are indicated by marginal arrows.

2. SPECIAL TOOLS

2.01 In addition to the usual set of teletypewriter tools, the following special tools will be needed:

- (1) TP77708 Spring Bender, for thin timing springs.
- (2) TP98055 Spring Bender, for heavy timing springs.

3. LUBRICATION

3.01 Lubrication should be done in the order shown, with one or two drops of oil, except where otherwise specified.

- (1) Cam-cylinder shaft—fill the 2 oilcups.
- (2) Clutch—sliding member.
- (3) Cam-felt oiler rings—saturate felt with oil.
- (4) Clutch-throwout lever—bearings.
- (5) Contact-lever pivoting shaft.
- (6) Gear—apply light film of grease.
- (7) Motor pinion—apply light film of grease.
- (8) Motor-bearing oiler—fill the 2 oilers with grease.
- (9) Detent-lever bearing point.
- (10) Detent-roller bearing point.
- (11) Detent camsleeve—apply light film of grease.
- (12) Oil both loops of all helical springs.

4. REQUIREMENTS AND PROCEDURES

4.01 CAM-SLEEVE END PLAY

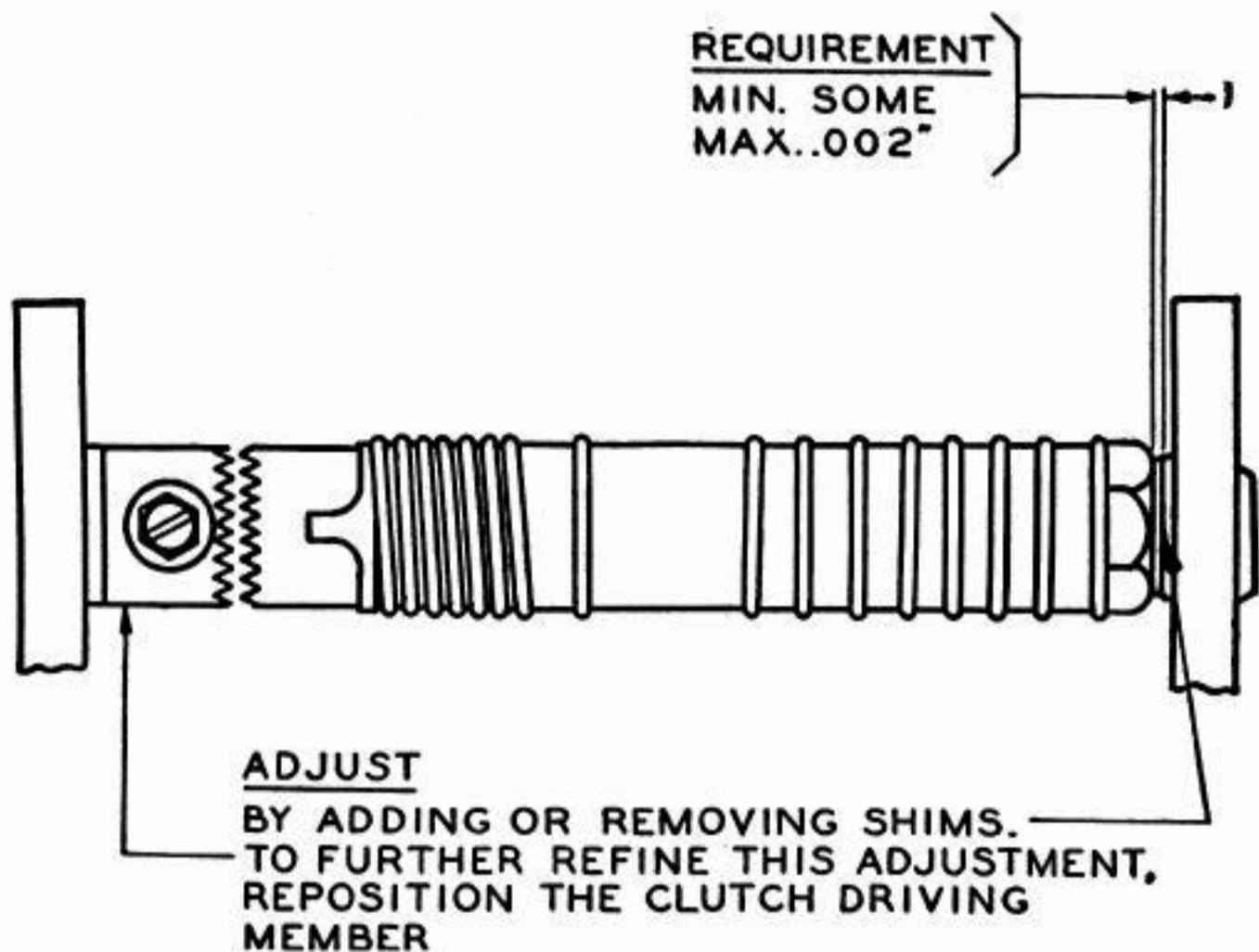

4.02 CLUTCH SPRING

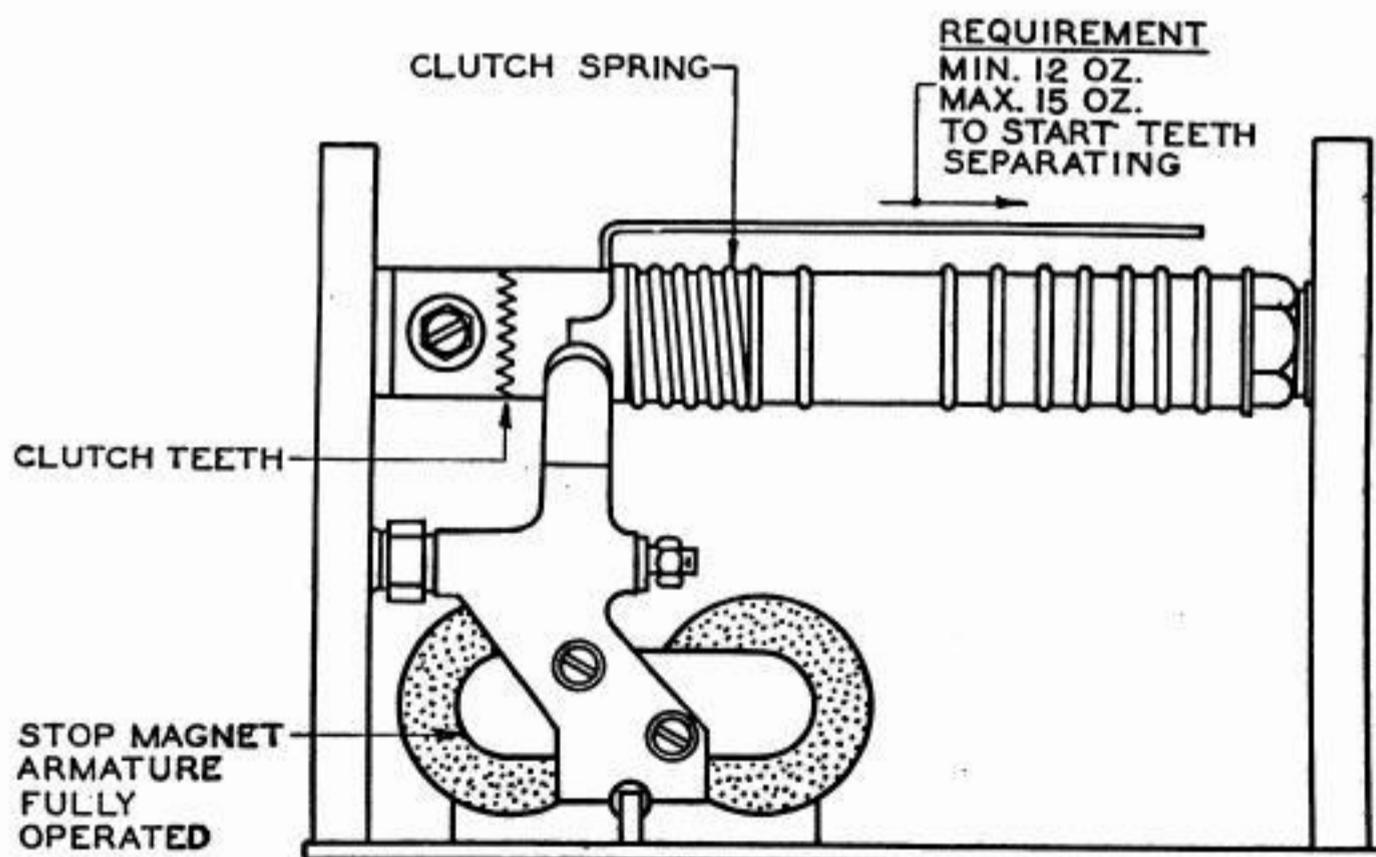

4.03 DETENT ECCENTRIC

The clutch should be fully cammed out when the shaft is in the stop position.

- (a) To adjust, position the detent lever by means of the detent eccentric screw (see 4.04 and 4.05).

4.04 DETENT-LEVER SPRING

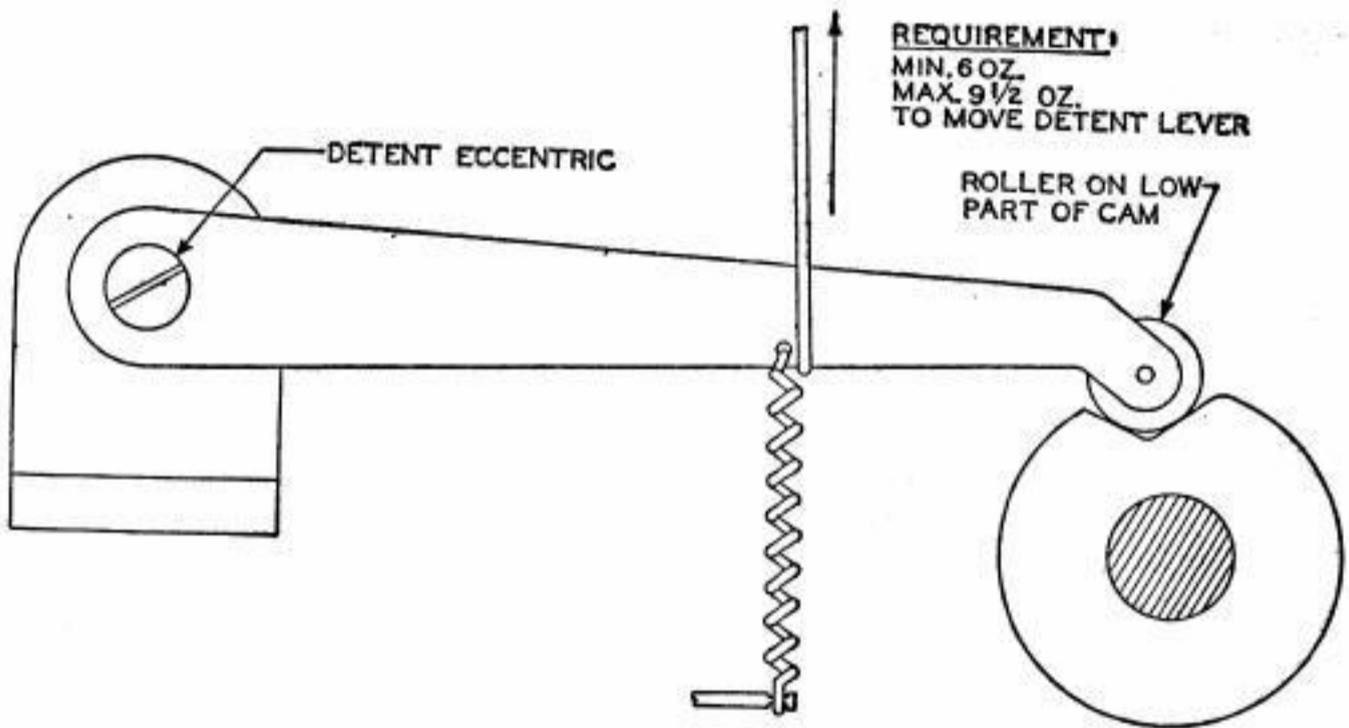

4.05 CLUTCH-TEETH CLEARANCE

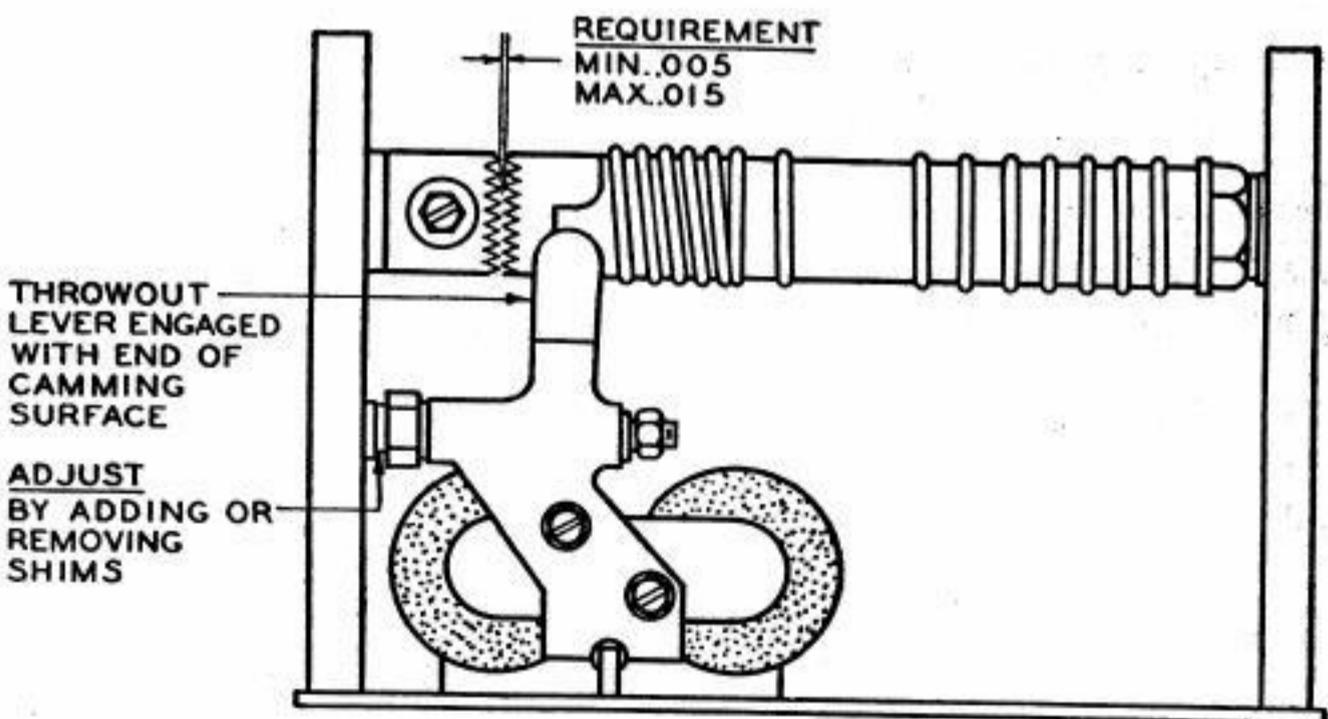

4.06 THROWOUT-LEVER CLEARANCE

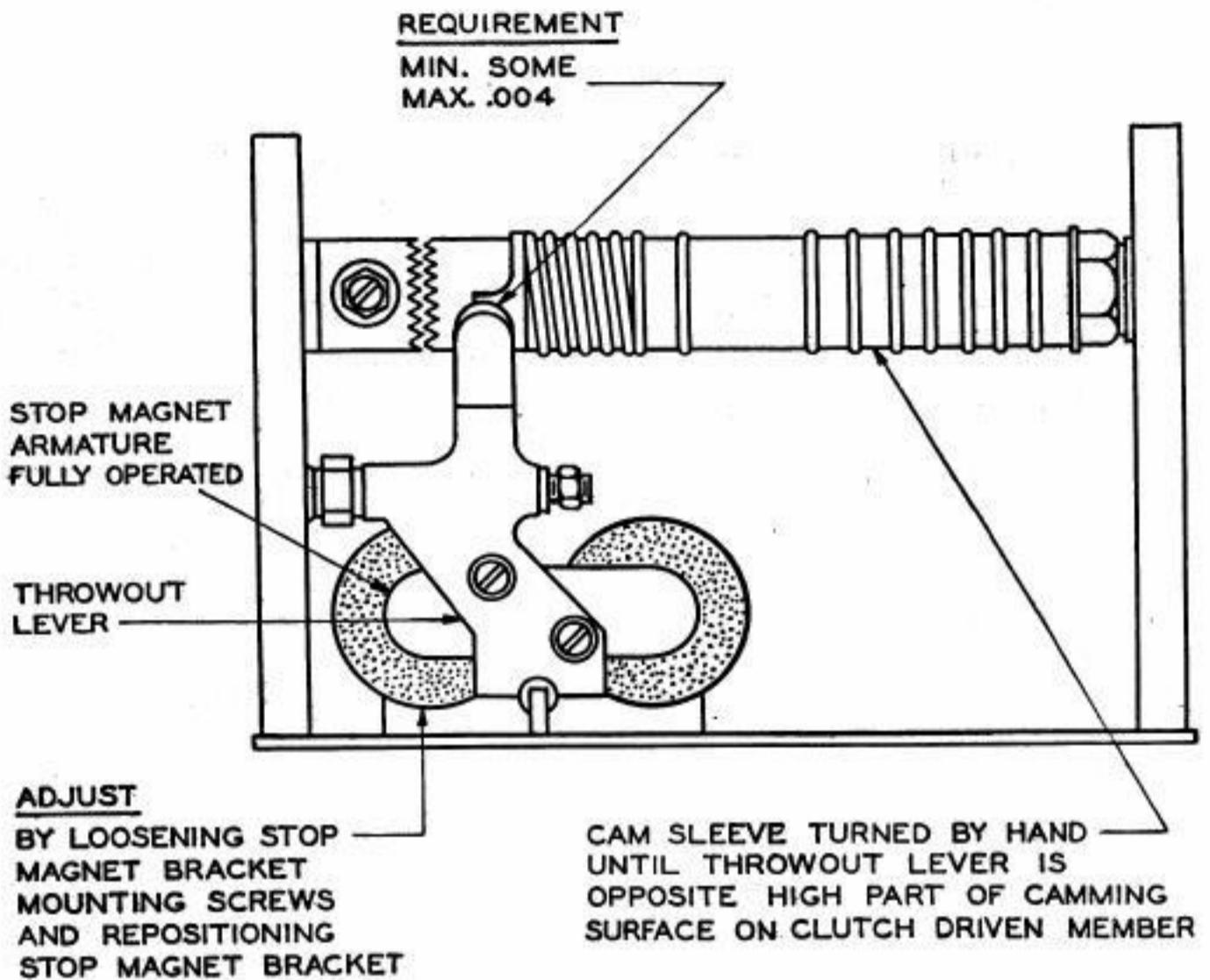

4.07 ARMATURE SPRING

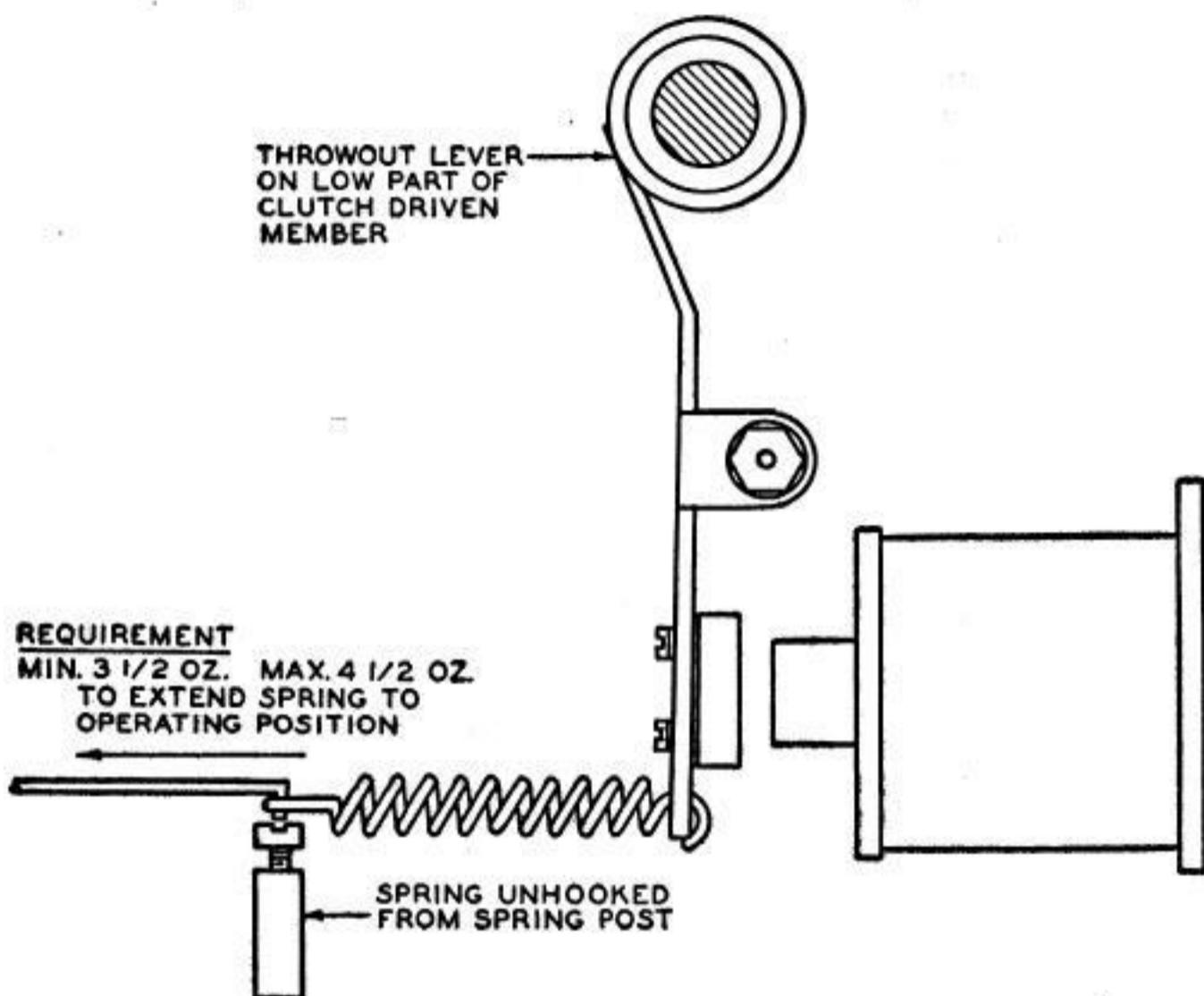

4.08 TRANSMITTING-CONTACT GAP

Preliminary Adjustment

- (a) With the transmitting-contact levers on the high parts of their cams, back up the backstop adjusting screws all the way. The contact gap should be min 0.035 inch, max 0.040 inch.
- (b) Adjust by bending the short contact spring.
- (c) It should require about 7 oz, applied just above the contact point, to move the long contact spring away from its contact lever.
- (d) Adjust by bending the long contact spring.

Final Adjustment

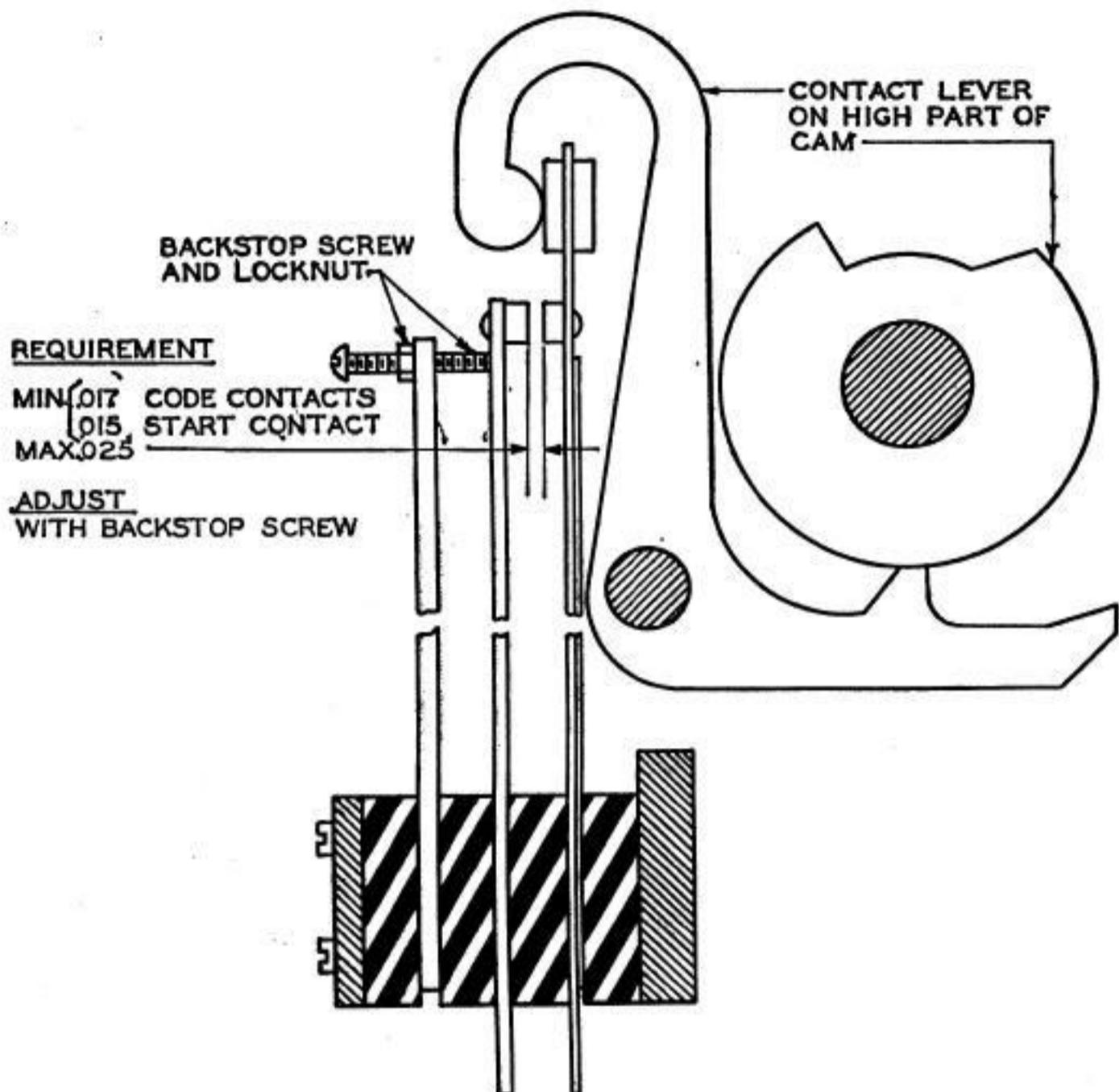

Note: The requirement given in this figure applies when a distortion test set is available for checking signals. If no distortion test set is available, contact gap requirements should be as follows:

<u>Operating Speed (wpm)</u>	<u>Gap on Code Contacts (Inches)</u>	<u>Gap on Start Contact (Inches)</u>
60, 75	0.017 to 0.023	0.017 to 0.023
100	0.020 to 0.025	0.020 to 0.025

4.09 SHORT TRANSMITTING-CONTACT SPRINGS

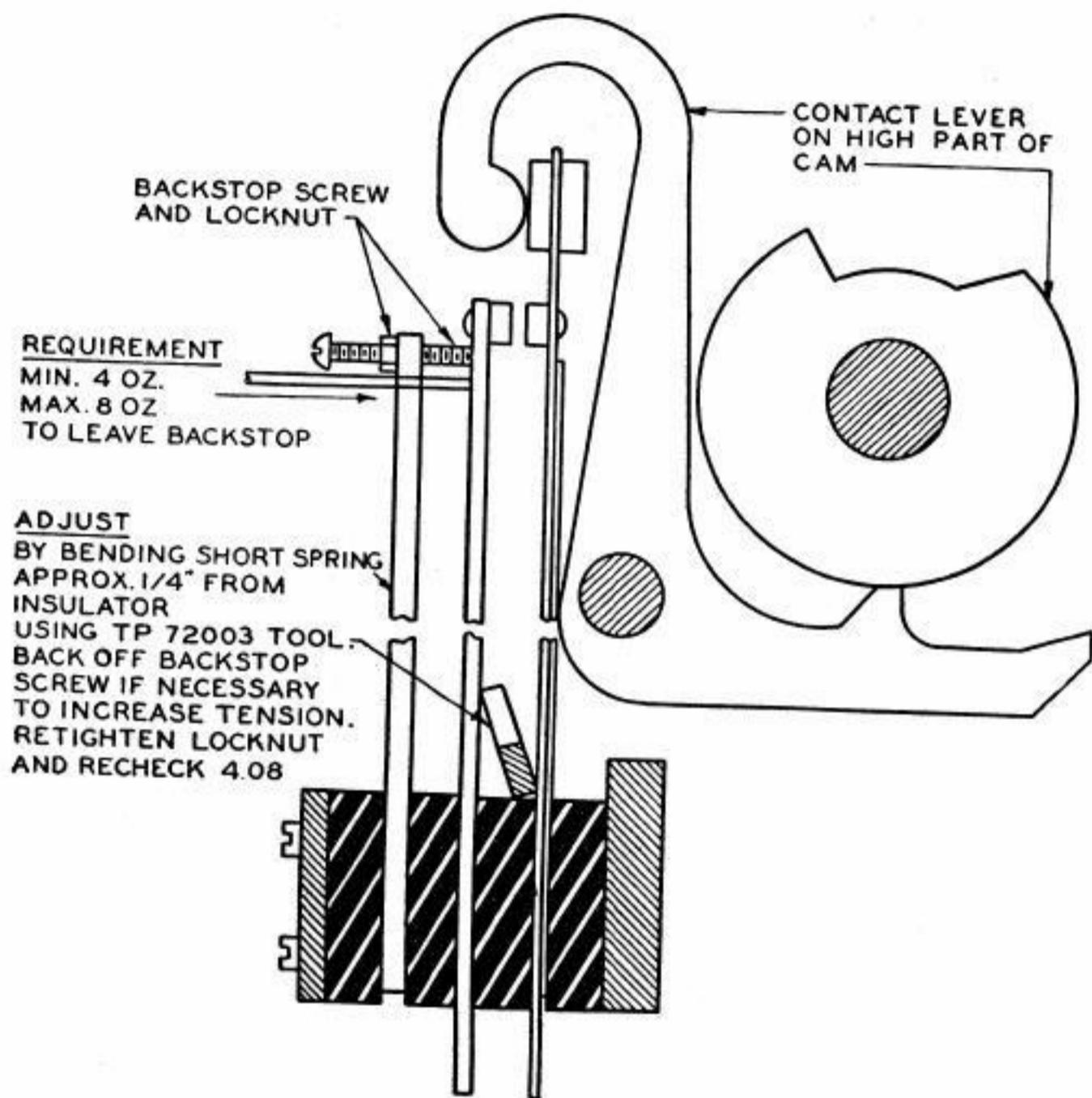

4.10 LONG TRANSMITTING-CONTACT SPRING

REQUIREMENT

MIN. 5 OZ.
MAX. 5 1/2 OZ.
TO OPEN CONTACTS

BACKSTOP SCREW
AND LOCKNUT

ADJUST

BY BENDING LONG SPRING
APPROX. 1/4" FROM
INSULATOR USING
TP 72003 TOOL.
BACK OFF BACKSTOP SCREW
IF NECESSARY TO
INCREASE TENSION.
RETIGHTEN LOCKNUT
AND RECHECK 4.08
AND 4.09

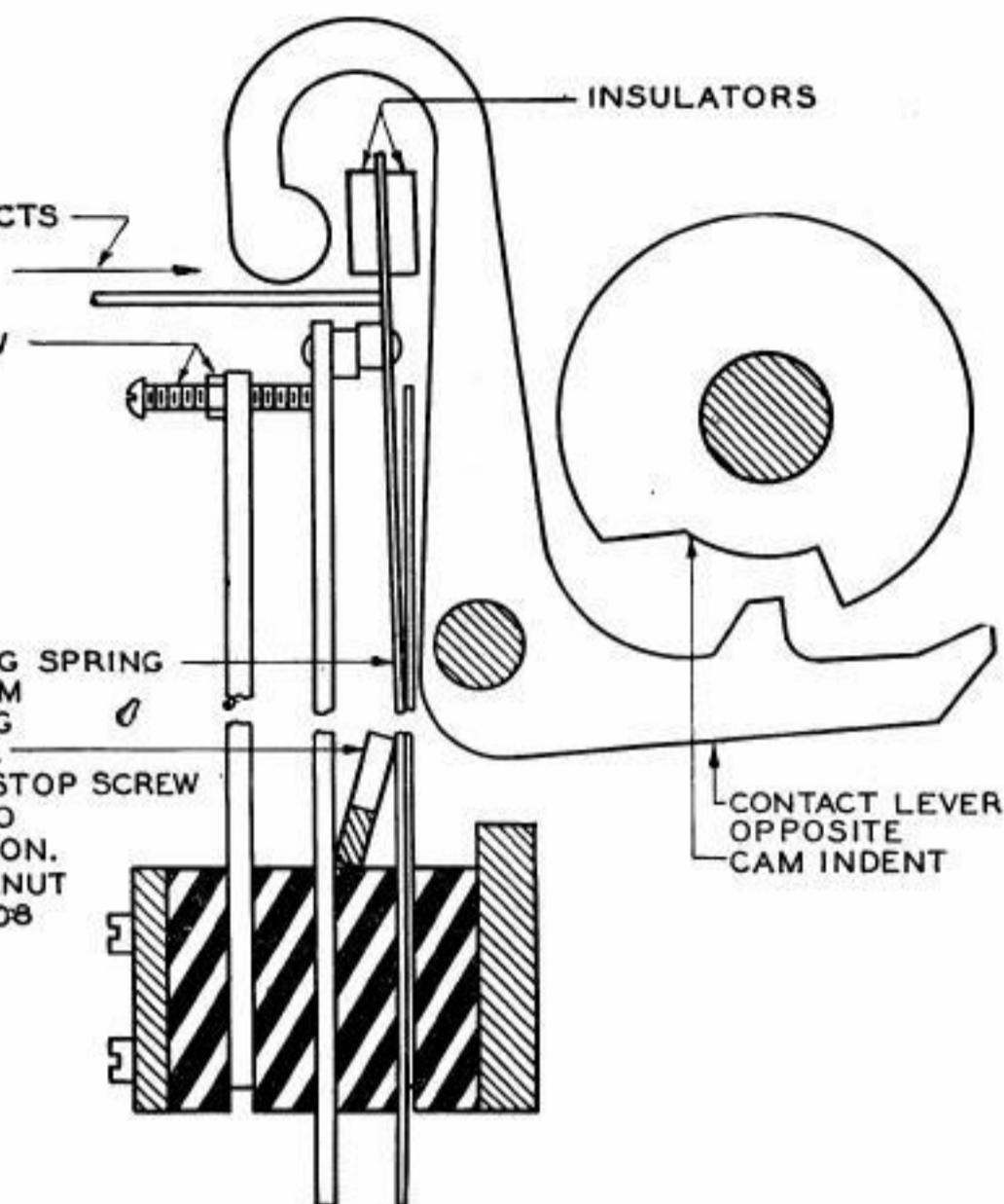

4.11 SPRING STIFFENERS

With the cam followers of the contact levers held as far as possible from their respective cams, see that there is at least 0.010 inch clearance at the closest point between the contact levers and the long contact spring stiffeners.

4.12 FRONT TIMING-CONTACT ADJUSTMENT

Note 1: With the unit turned on its right side, measure all tensions at the contact points with an 8-oz scale, held in a horizontal position.

Old-Style TP116962 Contact Assembly (with solid lower spring TP41720)

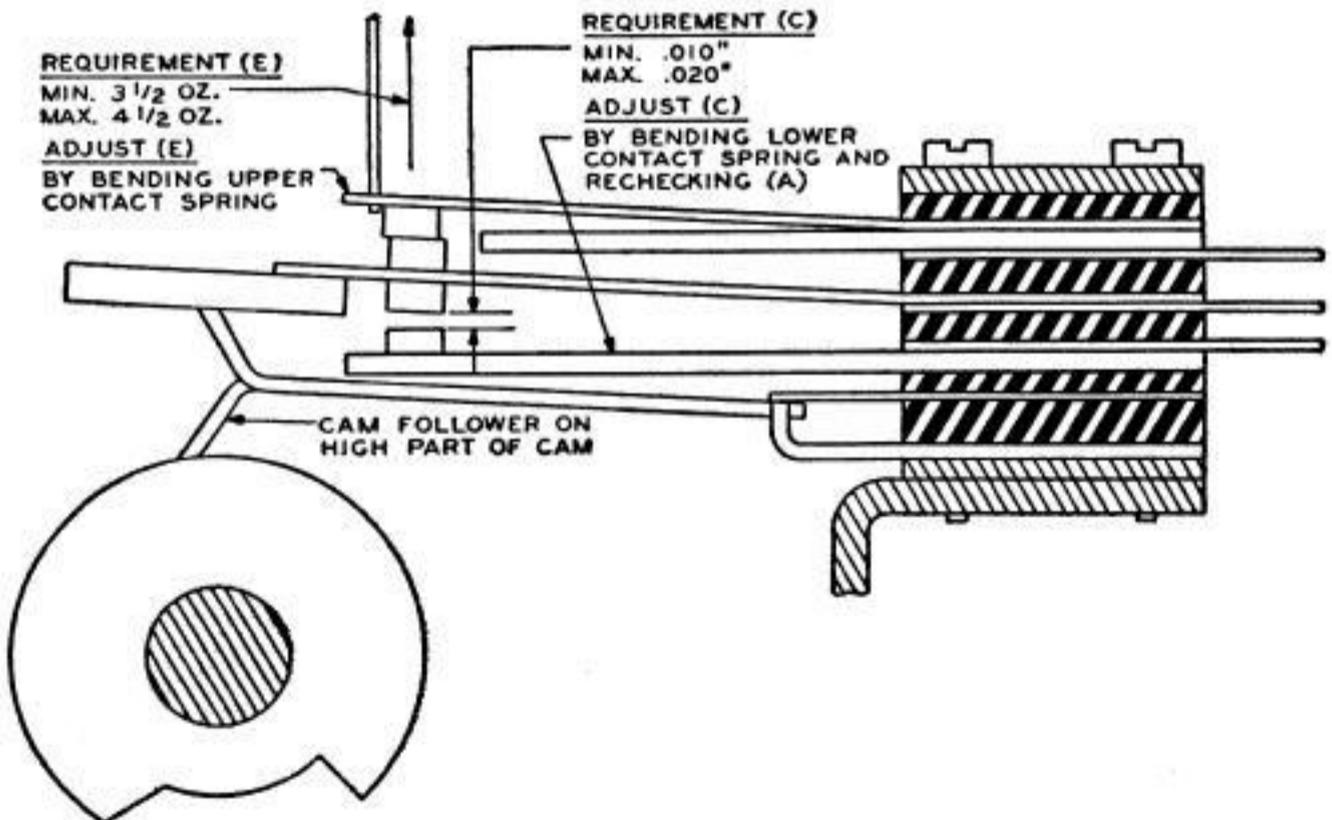
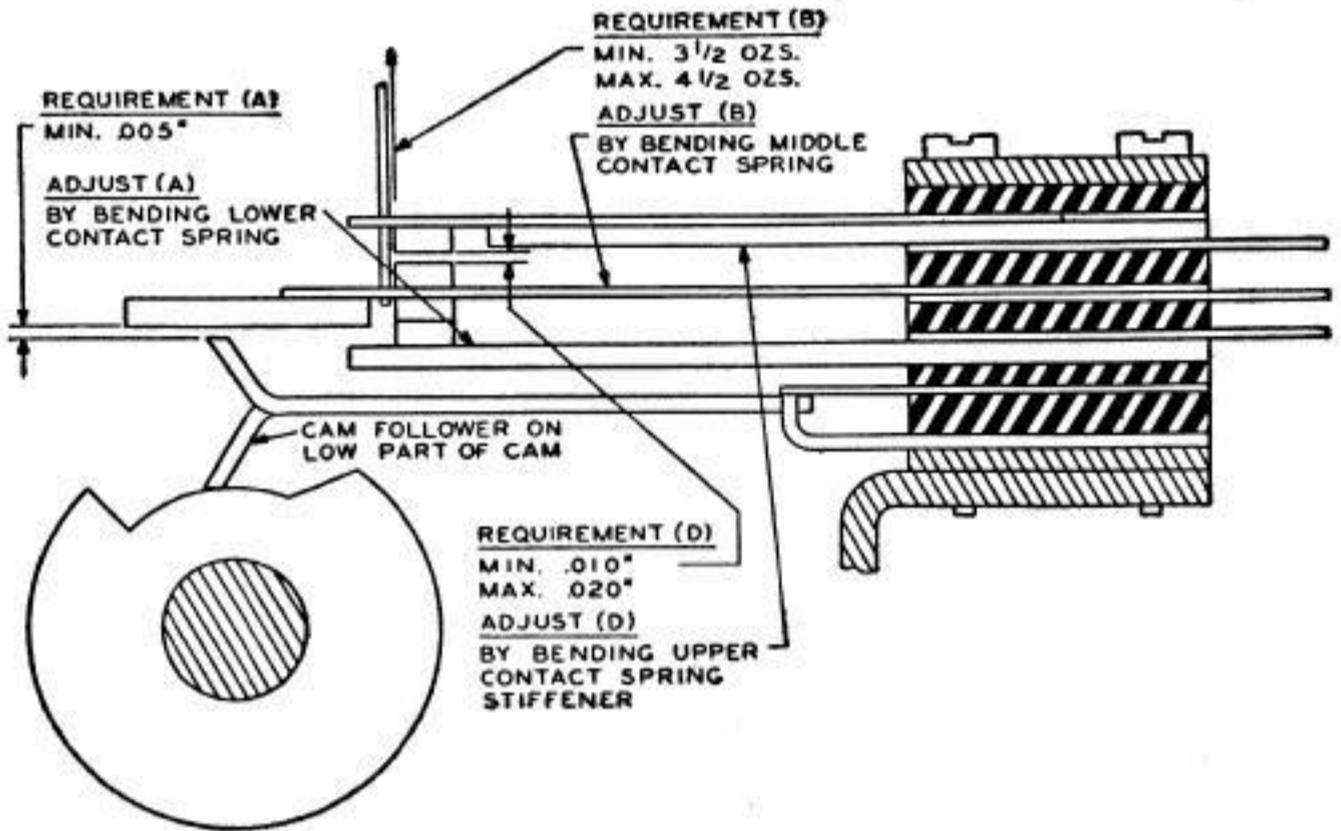

New-Style TP116962 Contact Assembly (with lower TP-84705 contact spring and TP105940 stiffener)

(a) Contact Follower on High Part of Cam

<u>Requirement</u>	<u>Adjustment</u>
(1) Min 0.015 inch, max 0.025 inch between lower contacts	Bend lower contact spring stiffener
(2) Min 2-1/2 oz, max 3-1/2 oz to separate lower contact from stiffener	Bend lower contact spring
(3) Some clearance, up to 0.005 inch, between upper contact spring and its stiffener	Bend upper contact spring

(b) Contact Follower on Low Part of Cam

<u>Requirement</u>	<u>Adjustment</u>
(1) Min 0.020 inch, max 0.030 inch between upper contacts	Bend upper contact spring stiffener
(2) Min 3 oz, max 4 oz to separate upper contact from stiffener	Bend upper contact spring
(3) Min 0.005 inch, max 0.015 inch between lower contact and stiffener	Bend middle contact spring
(4) Min 0.005 inch, between middle contact spring insulator and the end of cam follower	Bend lower contact spring

(c) Recheck adjustments

Note 2: All contacts should meet squarely. That is, a 0.003 inch gauge should not pass between the contacts at the edge for a depth of more than 3/64 inch.

4.13 REAR TIMING-CONTACT ADJUSTMENT

Note: With the unit turned on its right side, measure all tensions at the contact points with an 8-oz scale, held in a horizontal position. A maximum lengthwise misalignment of 0.030 inch is permissible on the outer pair of contacts.

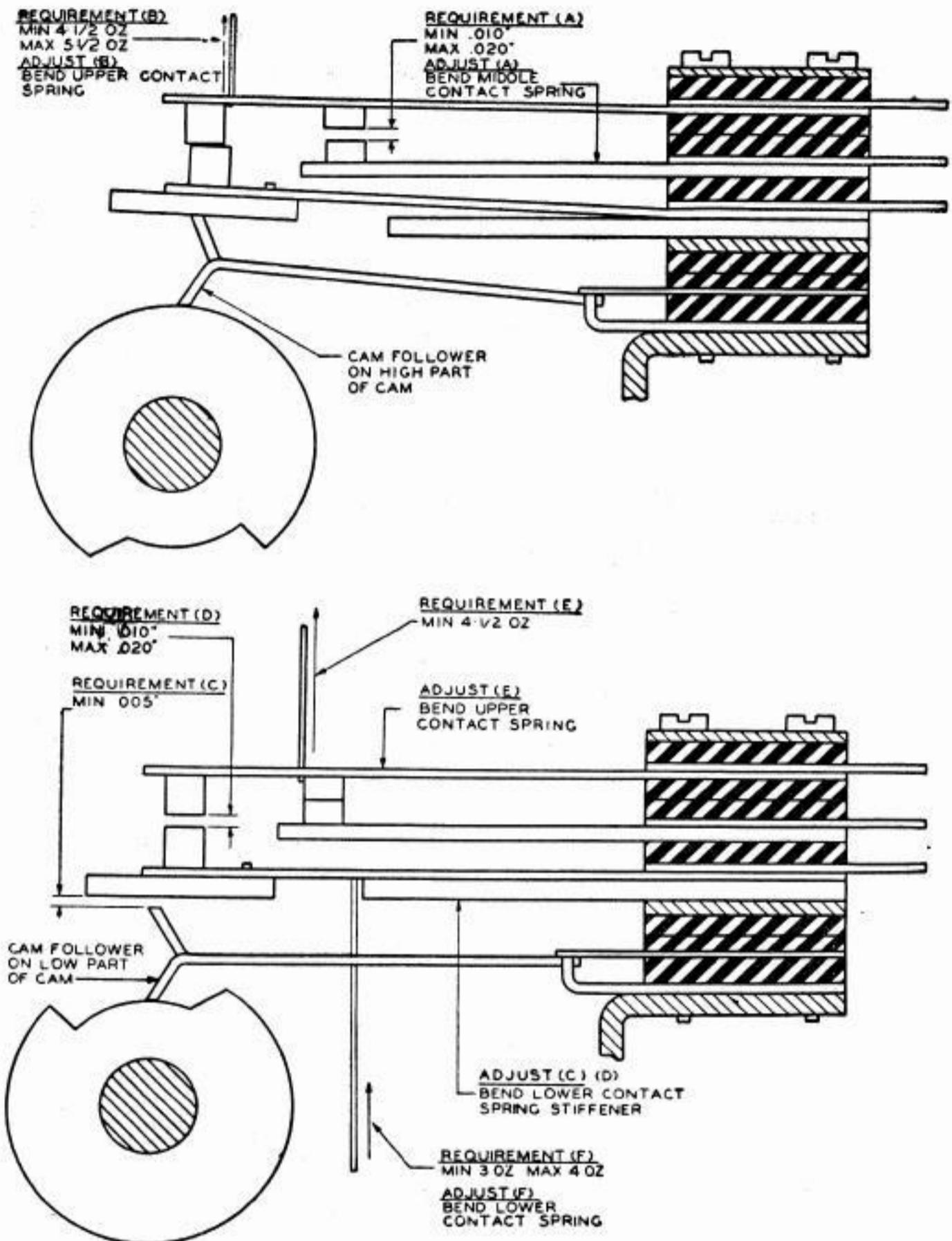

4.14 MOTOR PINION

- (a) During one complete revolution of the gear, there should be a barely perceptible amount of backlash between the motor pinion and the highest point of the distributor gear.
- (b) Gauge by eye and feel.
- (c) Adjust by loosening the three mounting screws and moving the distributor unit.