

**BELL SYSTEM PRACTICES**  
**Teletypewriter and Manual**  
**Telegraph Station and PBX**  
**Installation and Maintenance**

**SECTION P35.612**  
**Issue 1, February, 1934**  
**Standard**

**TELETYPEWRITER**  
**PRINTING AND SPACING ON UPPER CASE**  
**BLANK**  
**NON-PRINTING AND NON-SPACING ON LOWER**  
**CASE BLANK ON 14 TYPING UNIT**  
**REQUIREMENTS AND PROCEDURES**

**1. GENERAL**

1.01 This section outlines the apparatus requirements and adjusting procedures for the mechanism which provides for printing and spacing on upper case blank and prevents printing and spacing on lower case blank on 14 typing units.

1.02 The requirements and procedures section on 14 typing unit shall also be observed, except as stated herein.

1.03 Refer to the section on Teletypewriter Apparatus—General Requirements and Procedures for additional information necessary for the proper application of the requirements and procedures listed herein.

**REQUIREMENTS AND PROCEDURES**

**General**

2.01 Moving parts shall operate smoothly and be free from binding.

**Spacer Locking Bail Spring**

Note: This requirement replaces 3.37, Section P35.610, for typing units equipped with mechanism mentioned in 1.01.

2.02 The tension of the spacer locking bail spring shall be Min. 7-1/2 ozs. (210 gms.), Max. 8-1/2 ozs. (240 gms.), measured by hooking the end of spring balance in the upper loop of the spring and pulling vertically upward to position length (the position opposite where spring was hooked).

(a) Gauge with 138-58 (M) gauge.

#### Space Suppression Lever Clearances

2.03 Clearance between lower edge of space suppression lever and upper edge of blank pull bar projection shall be Min. .010", Max. .075", when the typing unit is in its stop position (pull bars held away from code bars) with the carriage in its unshifted position. See Fig. 1.

(a) Gauge minimum clearance with 75806 (M) gauge and maximum clearance with a piece of drill rod or wire measuring .075" diameter.

(b) Adjust by bending space suppression lever stop arm.

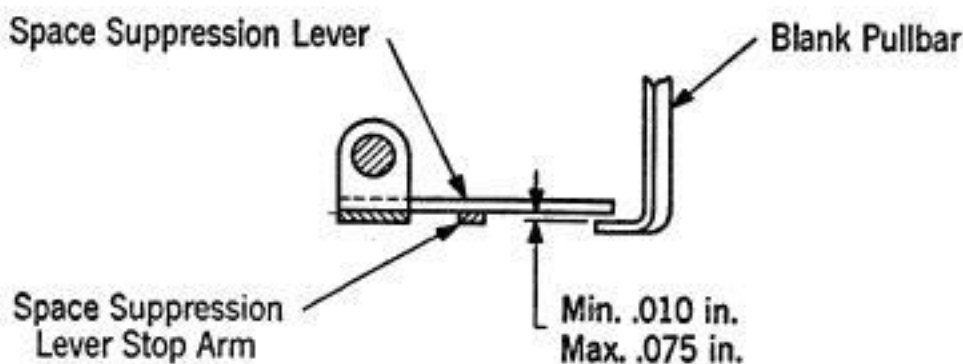

FIG. 1

2.04 Clearance between rear edge of space suppression lever and vertical edge of blank pull bar shall be Min. .066", Max. .040", with the carriage in the shifted position, and after the "blank" combination has been set up and the motor rotated by hand until the blank pull bar moves into the path set up for it in the code bars. See Fig. 2.

(a) Gauge clearance with pieces of wire or drill rod measuring .006" and .040" diameter, holding gauge parallel with centerline of space suppression lever.

(b) To adjust loosen suppression lever mounting plate clamp screws and move space suppression lever longitudinally with respect to its mounting plate. Check adjustment 2.05.

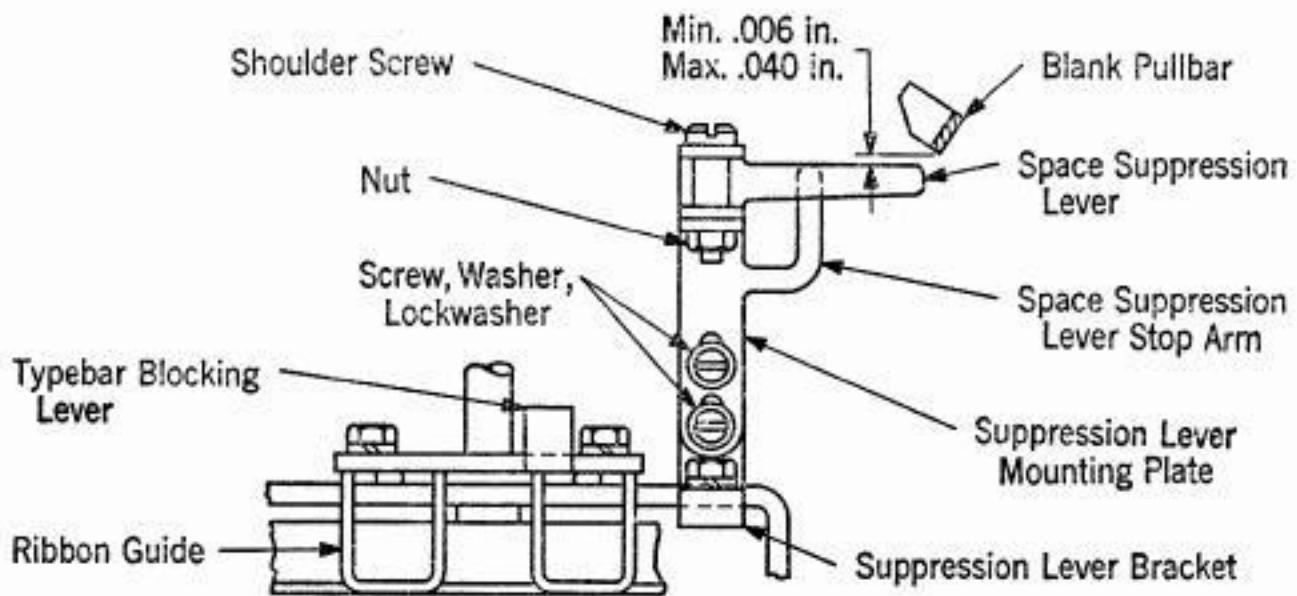

FIG. 2

2.05 Clearance between the end of space suppression lever and vertical edge of blank pull bar shall be Min. .006", Max. .020", when the motor has been rotated by hand until the pull bars are resting against code bars and with the carriage moved to a position where the space suppression lever is opposite the pull bar. See Fig. 3.

(a) Gauge clearance with pieces of wire or drill rod measuring .006" and .020" diameter.

(b) To adjust, move the space suppression lever laterally with respect to its mounting plate. Recheck adjustment 2.04 and tighten clamp screws.

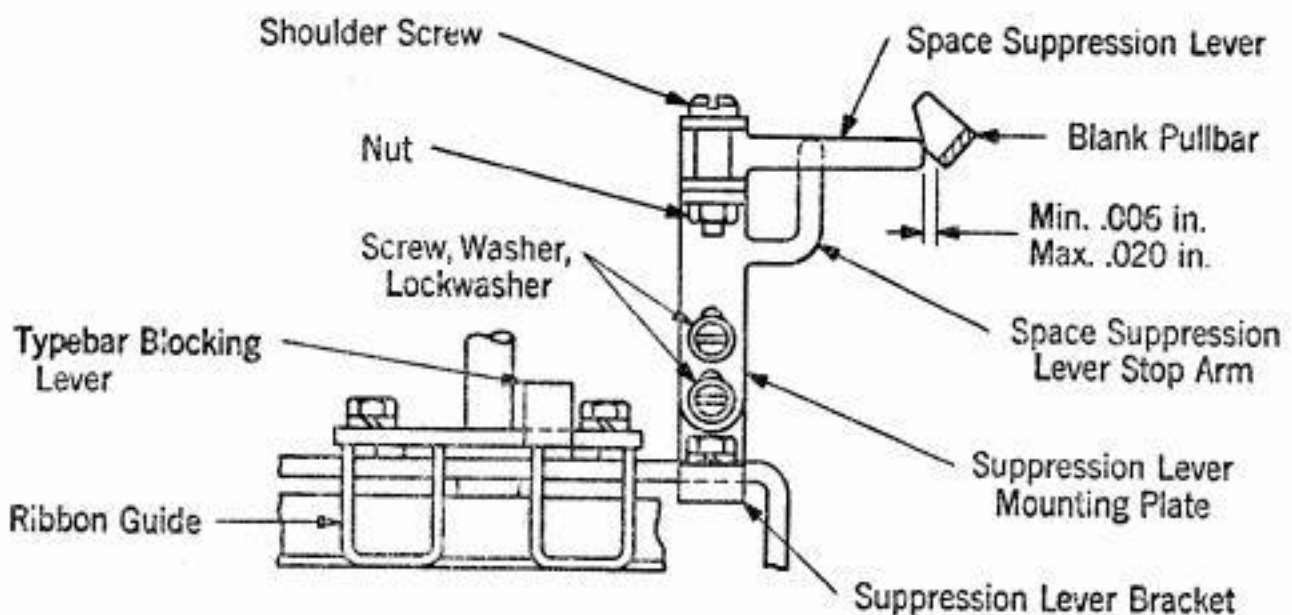

FIG. 3

### **Type Bar Blocking Bracket**

2.06 The "blank-hyphen" type bar when held in its operated position shall engage with the type bar blocking bracket and prevent the type pallet from pressing the ribbon and tape against the platen, when the carriage is in the unshifted position.

(a) To check, hold the "blank-hyphen" type bar in its operated position and see that the ribbon and tape are free to move with respect to the platen.

2.07 The "blank-hyphen" type bar when held in its operated position shall clear the type bar blocking bracket by not less than .010" when the carriage is in the shifted position and throughout a complete revolution of the platen.

(a) To check, hold the "blank-hyphen" type bar in its operated position at four equidistant points on periphery of platen, and gauge clearance with 75806 (M) gauge.