

BELL SYSTEM PRACTICES
Teletypewriter and Data Stations

ADDENDUM P34.501
Issue 2, February, 1962
AT&TCo Standard

28 TYPING UNIT

LUBRICATION

1. GENERAL

1.001 This addendum supplements Section P34.501, Issue 1.

1.002 This addendum is reissued to add information concerning adjustments which must be checked after each routine servicing.

The following change applies to Part 1 of the section:

(a) 1.03—added

1.03 Each time the 28 teletypewriter is given routine servicing, the adjustments listed in **PARTS REQUIRING ROUTINE CHECK** in the section covering requirements and adjustments of the 28 typing unit should be verified and, if necessary, remade in accordance with that section.

3. LUBRICATION DETAILS FOR VARIABLE FEATURES

The following change applies to Part 3 of the section:

(a) 3.25—added

3.25 Form-feedout Mechanism

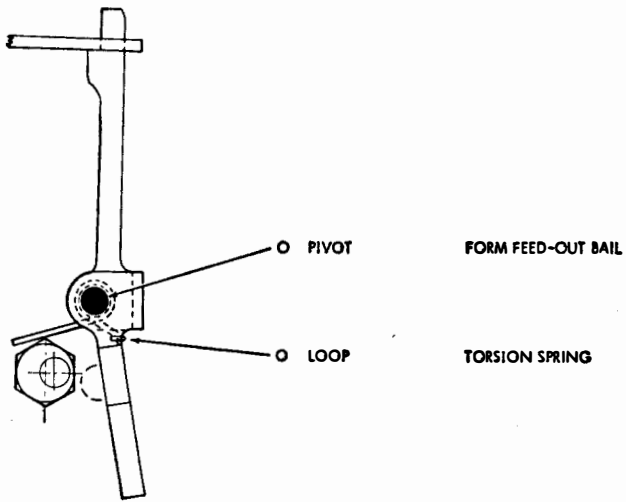

BELL SYSTEM PRACTICES
Teletypewriter and Data Stations

SECTION P34.501
Issue 2, November, 1963
AT&T Co Standard

28 TYPING UNIT
LUBRICATION

CONTENTS	PAR. NO.
1. GENERAL	1.01-1.03
2. LUBRICATION	
Carriage Return Drum.....	2.43, 2.46
Clutch Triplevers and Camfollowers.....	2.52, 2.56
Codebar Mechanism.....	2.28, 2.35, 2.37
Codebar-shift Mechanism.....	2.05, 2.06
FIGS-LTRS Shift Mechanism.....	2.38-2.40
FIGS-LTRS Shift Slide.....	2.15, 2.17
Form Feedout Mechanism.....	2.86
Function Reset Bail Mechanism.....	2.21, 2.23
Function Rocker-shaft Mechanism.....	2.15, 2.18
Horizontal Positioning Mechanism.....	2.48-2.51
Horizontal Tabulator (Earlier Design).....	2.64, 2.66-2.70
Horizontal Tabulator (Later Design).....	2.71-2.80
Line-feed Mechanism.....	2.19, 2.20
Mainshaft.....	2.52-2.54
Oscillating Mechanism.....	2.38, 2.41, 2.42
Page Feedout Mechanism.....	2.81, 2.82
Paper-feed Mechanism.....	2.35, 2.36
Paper-out Alarm Mechanism.....	2.83
Parallel Code-reading Contacts.....	2.89
Print Suppression and Off-line Stunt Shift Control	2.87
Print Codebar Solenoid.....	2.29, 2.30
Printing Clutch Blocking Mechanism.....	2.29, 2.30
Printing Mechanism.....	2.31-2.33
Printing Track Guide.....	2.43, 2.45
Ribbon-feed Mechanism (Right Side).....	2.01-2.03
Ribbon-feed Mechanism (Left Side).....	2.24-2.26
Ribbon-reverse Mechanism.....	2.15, 2.16
Selector Cam Clutch.....	2.52, 2.55

Selector Mechanism.....	2.05, 2.07, 2.08
Shift and Stripper-bail Mechanisms Operated from Function Clutch	2.12-2.14
Single-double Line-feed Mechanism.....	2.21, 2.22
Spacing Drum Mechanism.....	2.43, 2.44, 2.47
Spacing Mechanism.....	2.57-2.60
Sprocket-feed Mechanism.....	2.61-2.63
Stripper-blade Mechanism.....	2.09, 2.11
Stuntbox Mechanism.....	2.09, 2.10
Typebox Carriage.....	2.31, 2.34
Universal Contact Mechanism (Selector).....	2.84
Universal Contact Mechanism (Stuntbox).....	2.85
Universal Drum.....	2.64, 2.65
Vertical Positioning Mechanism (Right Side)..	2.01, 2.04
Vertical Positioning Mechanism (Left Side)..	2.24, 2.27
Vertical Tabulator.....	2.88

3. ASSOCIATED BELL SYSTEM PRACTICES 3.01

1. GENERAL

1.01 This section provides the lubrication procedures for the maintenance of the 28 typing unit including variable and auxiliary features. This material, together with that contained in the section entitled Teletypewriter Apparatus, Lubrication, General Information and Routines, gives the complete information for lubricating the typing unit. The lubrication symbols used herein are the same as those in the general section. However, the symbol O is used in this section to mean only one drop of oil. The symbol O2 is used to specify 2 drops of oil.

1.02 The section is reissued to:

- (a) Add a more detailed table of contents.
- (b) Improve the locator photographs by labeling the identifying arrows with the names of the mechanisms instead of paragraph numbers.
- (c) Revise 2.08 as authorized by P98.999.32.
- (d) Add one locator photograph (2.75) and three line drawings (2.87-2.89).

Marginal arrows are not used to indicate changes.

1.03 The typing unit should be lubricated before being placed in service as specified in the section entitled Preparation of Teletypewriter Apparatus for Installation. After a few weeks in service, it should ordinarily be relubricated to make certain that all the specified points have received lubricant. Thereafter, because of the varying conditions at each station, the typing unit should be lubricated as often as specified by the

local instructions. The following lubrication intervals are suggested as a guide for use under normal operating conditions.

OPERATING SPEEDS

(Words per Minute)

60
75
100

LUBRICATING INTERVALS

(Whichever occurs first)

3000 hours or 1 year
2400 hours or 9 months
1500 hours or 6 months

2. LUBRICATION

2.01 Ribbon-feed and Vertical Positioning Mechanisms (Right Side)

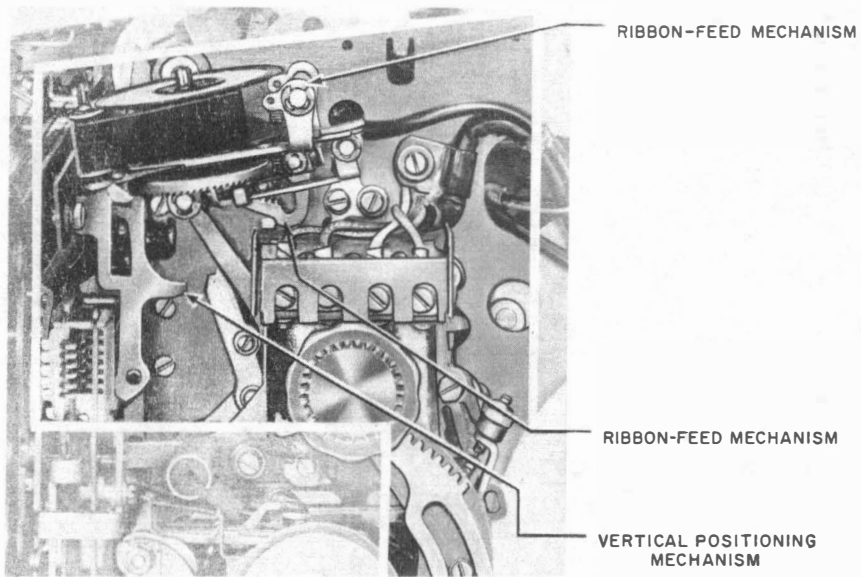

2.02 Ribbon-feed Mechanism

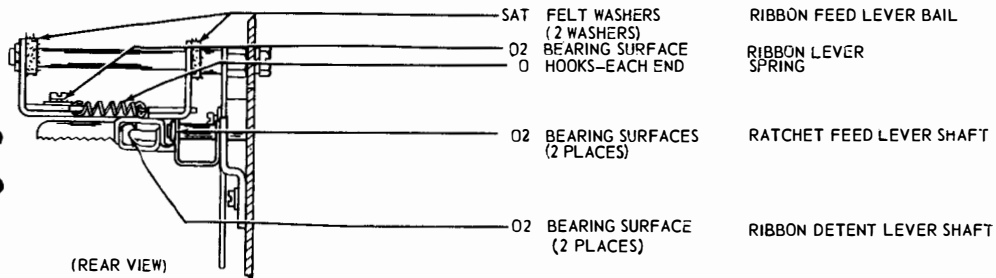
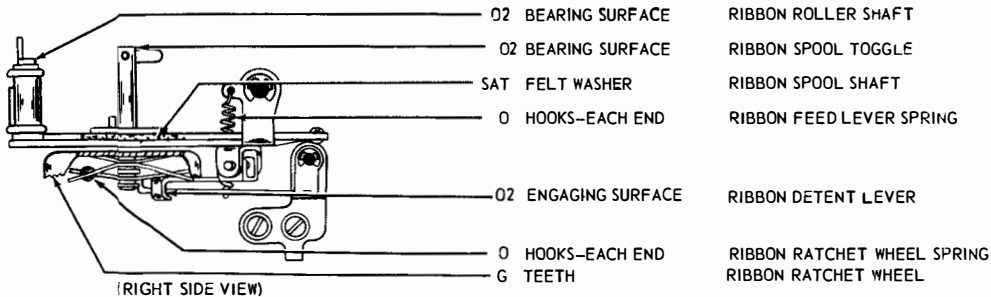

28 TYPING
UNIT
LUBRI-
CATION

P34.501

Page 5

2.03 Ribbon-feed Mechanism (Contd)

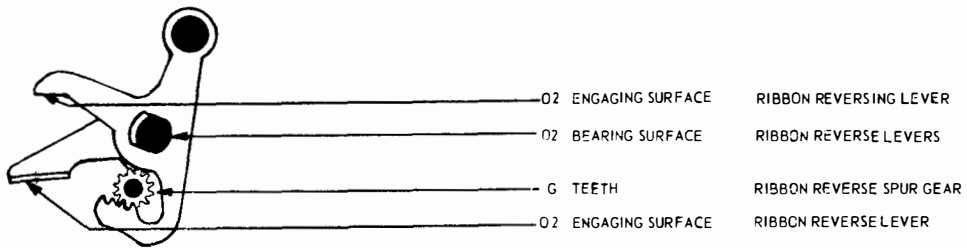

2.04 Vertical Positioning Mechanism

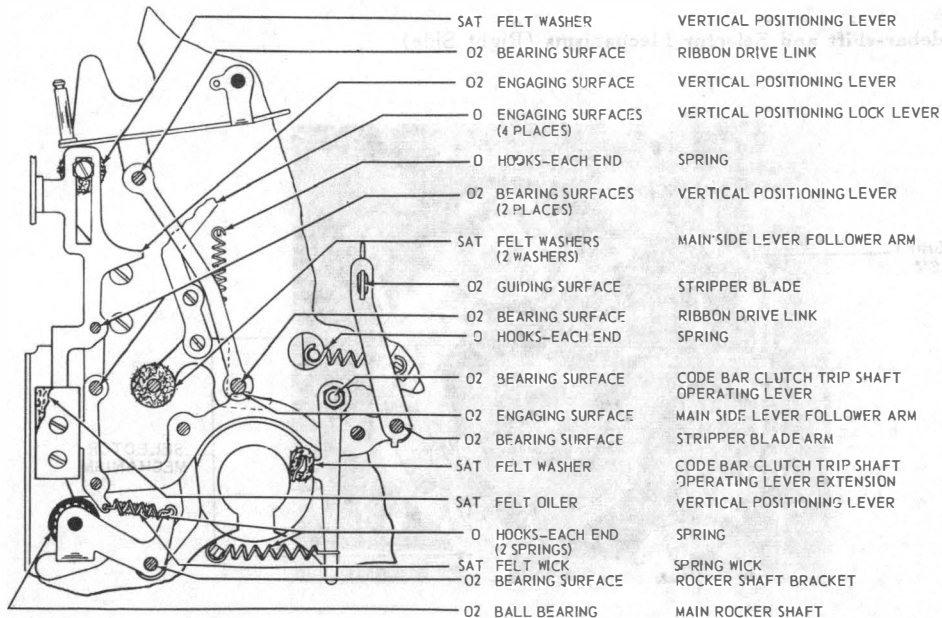

2.05 Codebar-shift and Selector Mechanisms (Right Side)

CODEBAR-SHIFT
MECHANISM

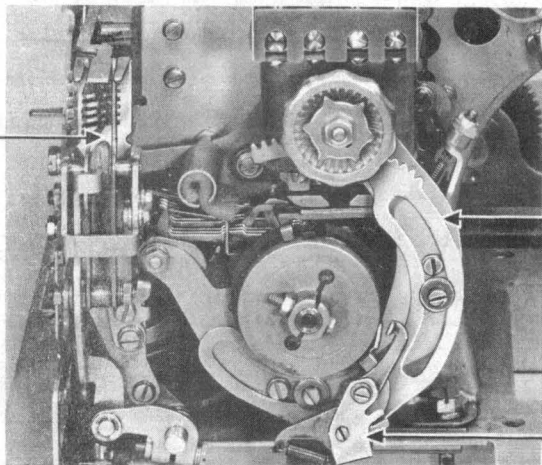

SELECTOR
MECHANISM

2.06 Codebar-shift Mechanism

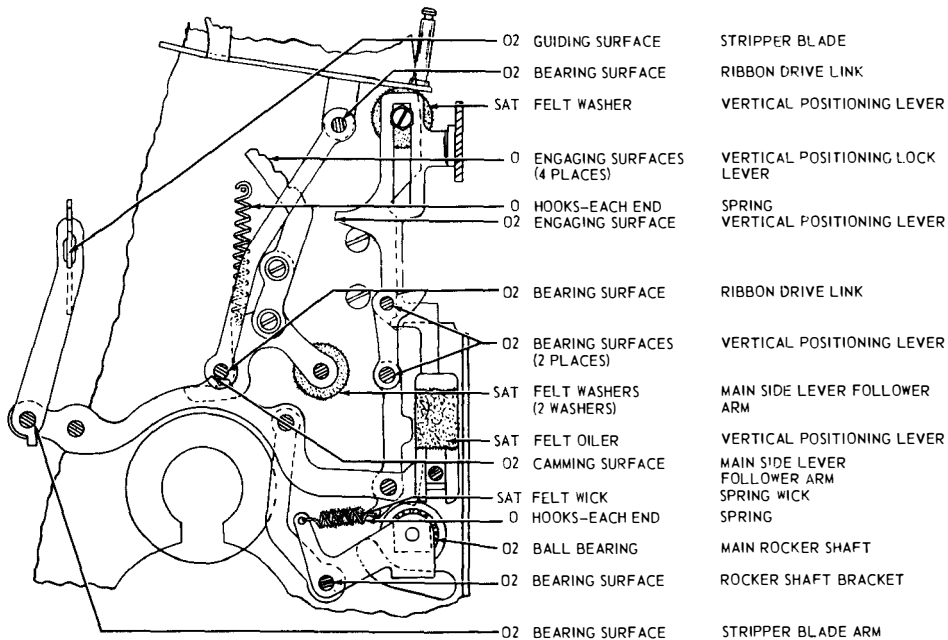

28 TYPING
 UNIT
 LUBRI-
 CATION

P34.501

2.07 Selector Mechanism

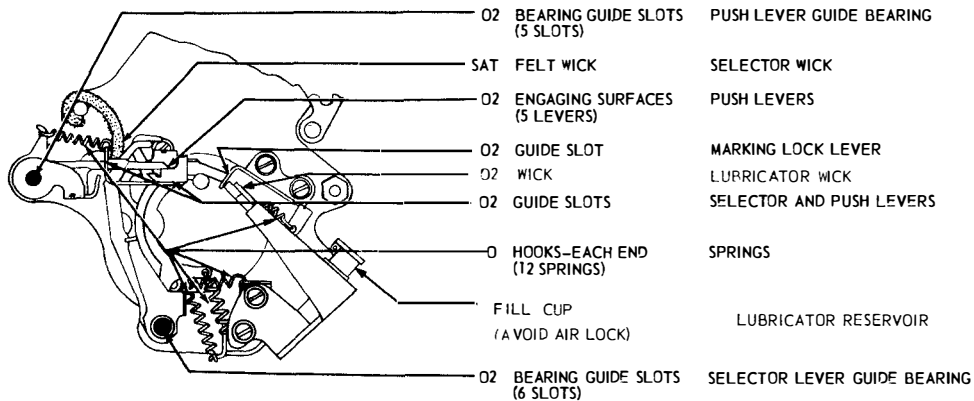

2.08 Selector Mechanism (Contd)

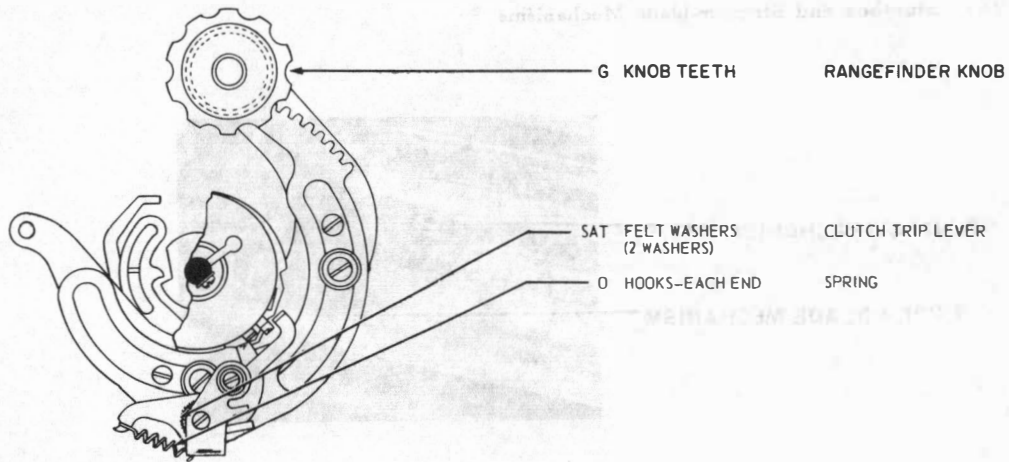

28 TYPING
UNIT
LUBRI-
CATION

P34.501

Page 11

2.09 Stuntbox and Stripper-blade Mechanisms

STUNTBX MECHANISM

STRIPPER-BLADE MECHANISM

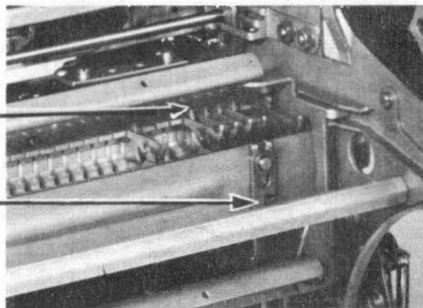

2.11 Stripper-blade Mechanism

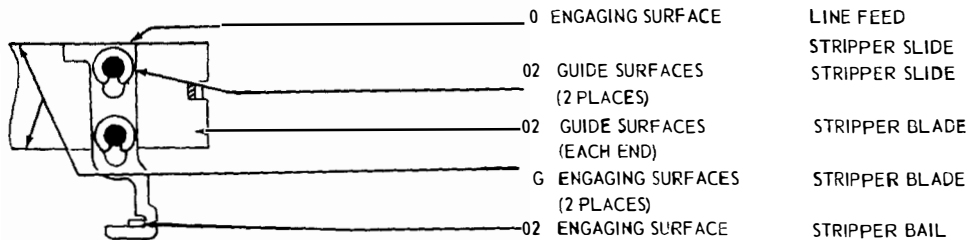
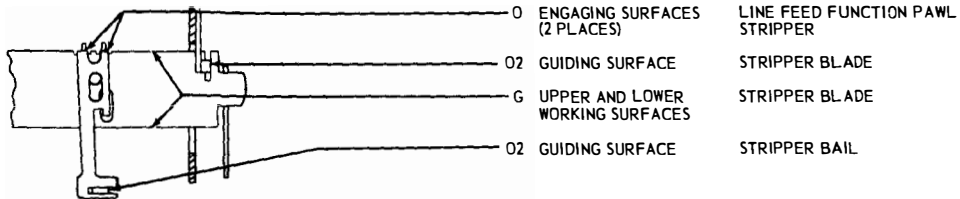

2.10 Stuntbox Mechanism

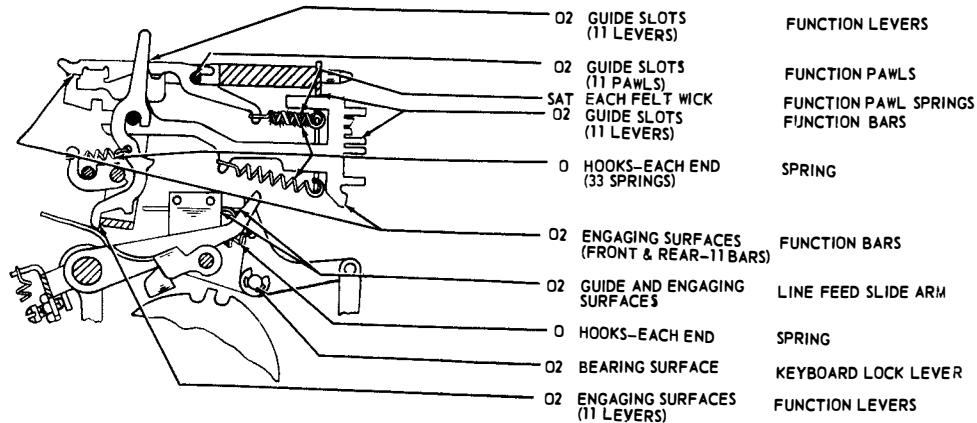

28 TYPING
UNIT
LUBRI-
CATION

2.12 Shift and Stripper-bail Mechanisms Operated from Function Clutch (Rear)

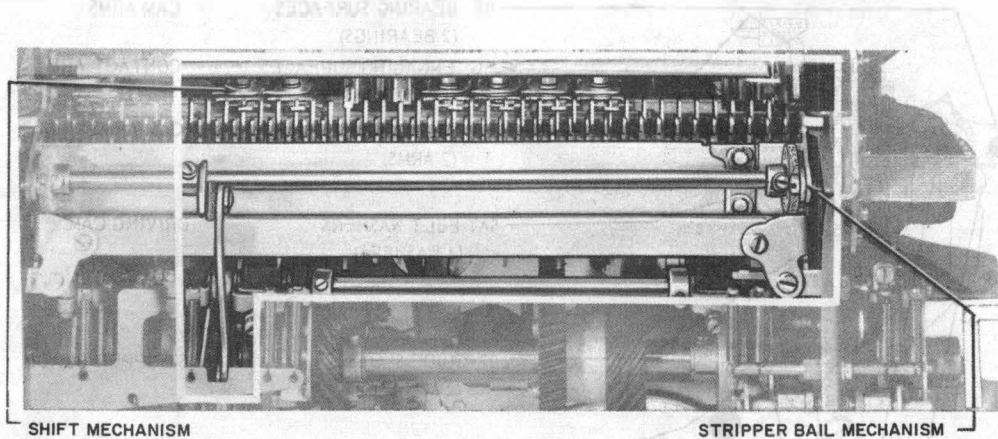

28 TYPING
UNIT
LUBRI-
CATION

P34.501

Page 15

2.13 Stripper Bail Operated from Function Clutch

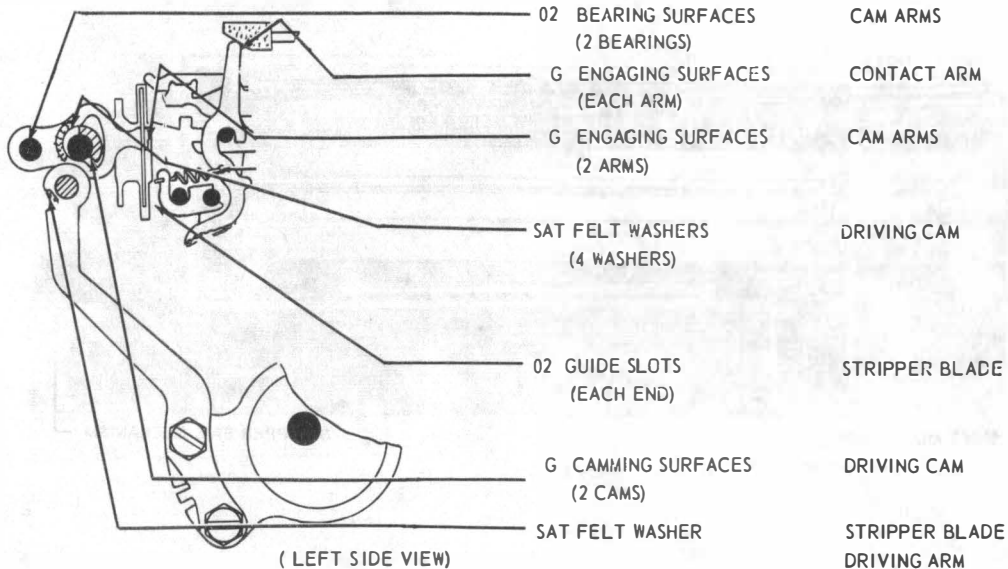

2.14 Shift and Stripper-bail Mechanisms Operated from Function Clutch

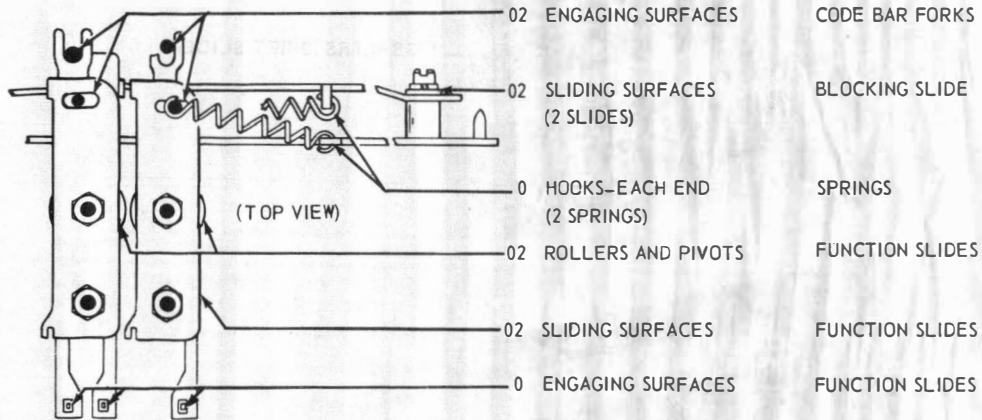

2.15 Ribbon-reverse FIGS-LTRS Shift-slide, and Function Rocker-shaft Mechanisms (Rear)

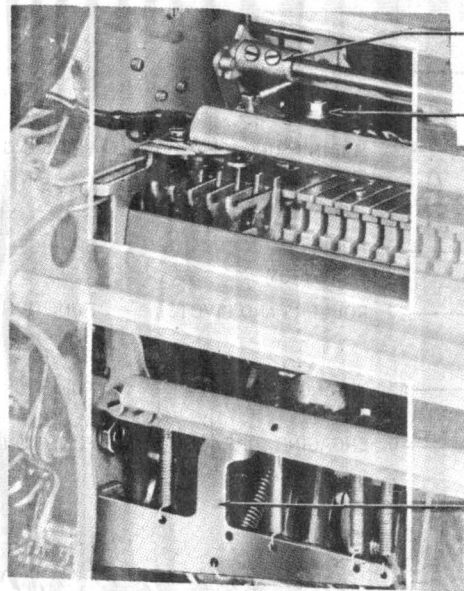

RIBBON-REVERSE MECHANISM

FIGS-LTRS SHIFT SLIDE

FUNCTION ROCKER-SHAFT
MECHANISM

2.16 Ribbon-reverse Mechanism

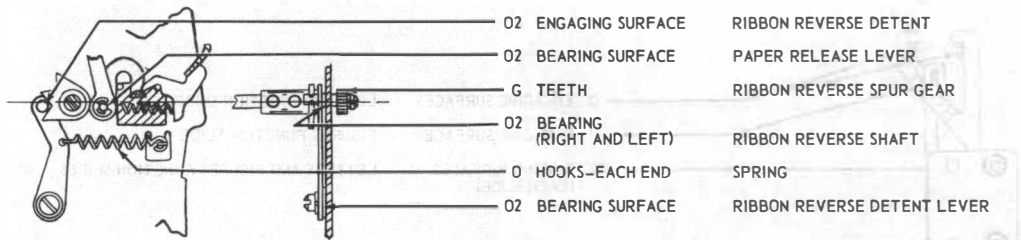

28 TYPING
UNIT
LUBRI-
CATION

P34.501
Page 19

2.17 FIGS-LTRS Shift Slide

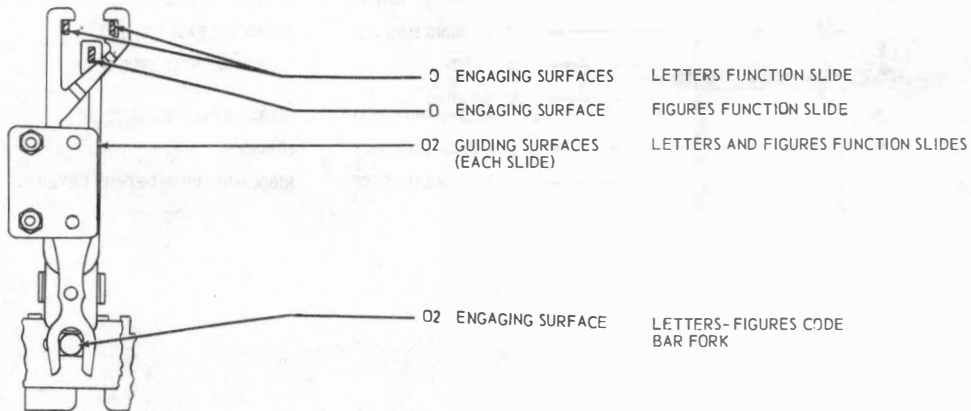

2.18 Function Rocker-shaft Mechanism

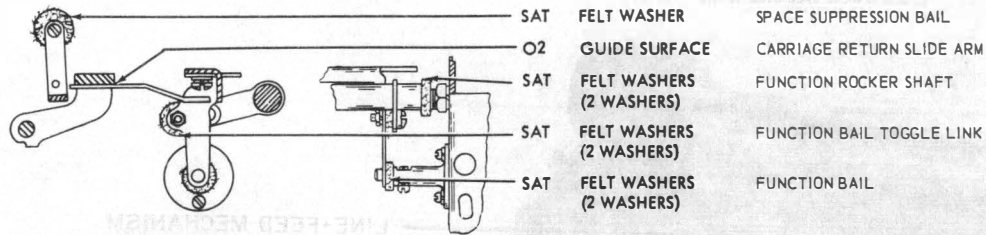

28 TYPING
UNIT
LUBRI-
CATION

P34.501

Page 21

2.19 Line-feed Mechanism (Rear)

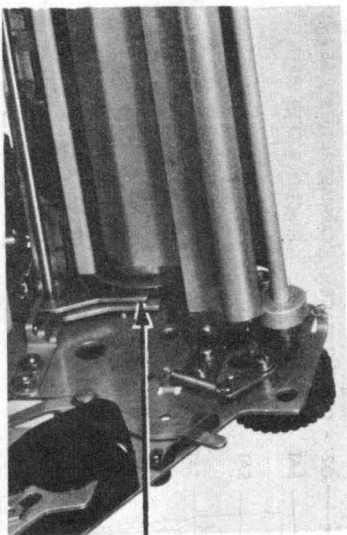

LINE-FEED MECHANISM

2.20 Line-feed Mechanism

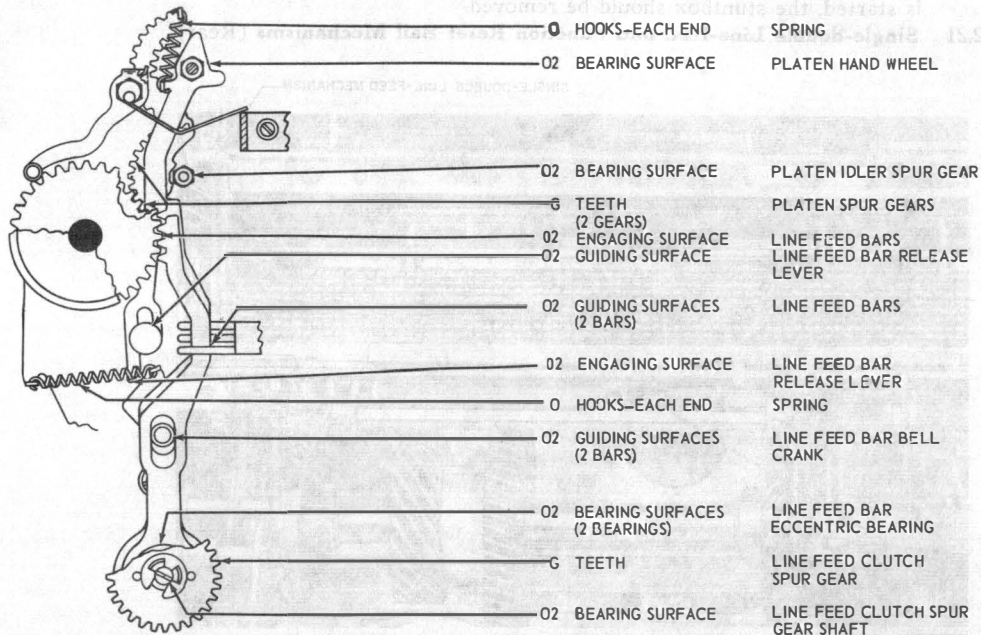

28 TYPING
UNIT
LUBRI-
CATION

P34.501

Page 23

Note: Before lubrication shown in 2.21 to 2.23, inclusive, is started, the stuntbox should be removed.

2.21 Single-double Line-feed and Function Reset Bail Mechanisms (Rear)

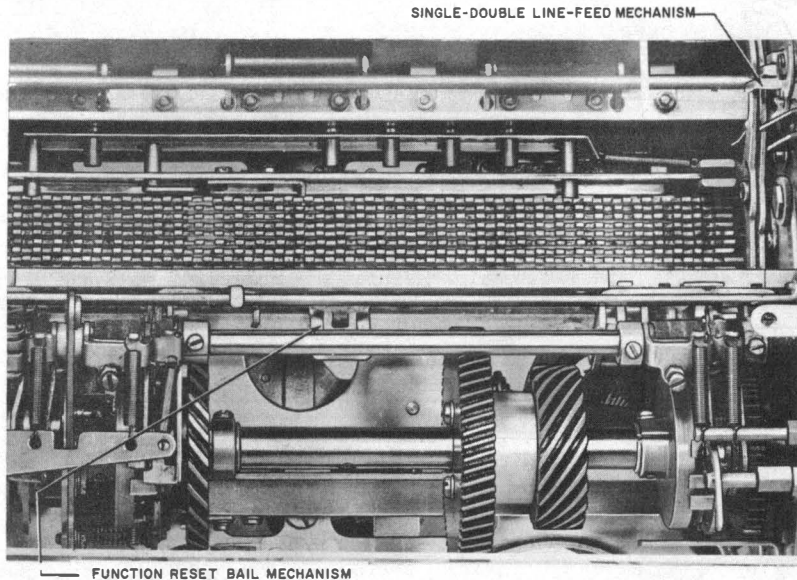

2.22 Single-double Line-feed Mechanism

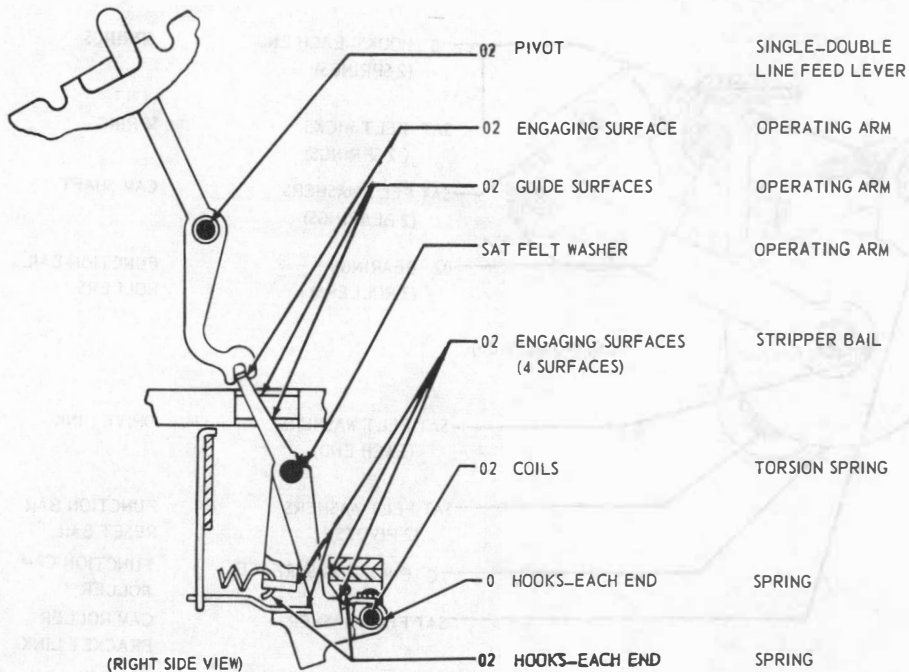

28 TYPING
UNIT
LUBRI-
CATION

P34.501

Page 25

2.23 Function Reset Bail Mechanism

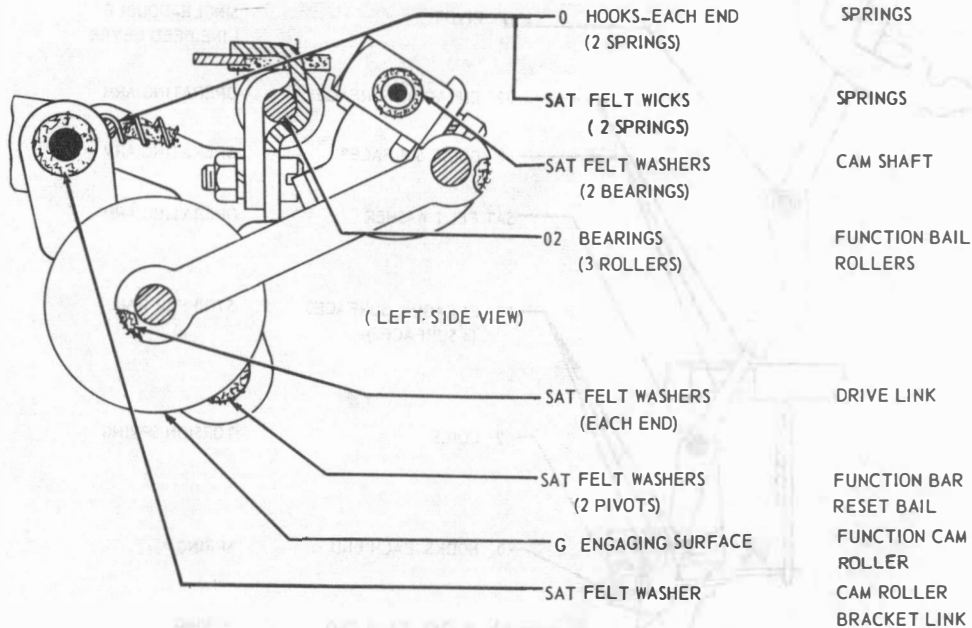

2.24 Ribbon-feed and Vertical Positioning Mechanisms (Left Side)

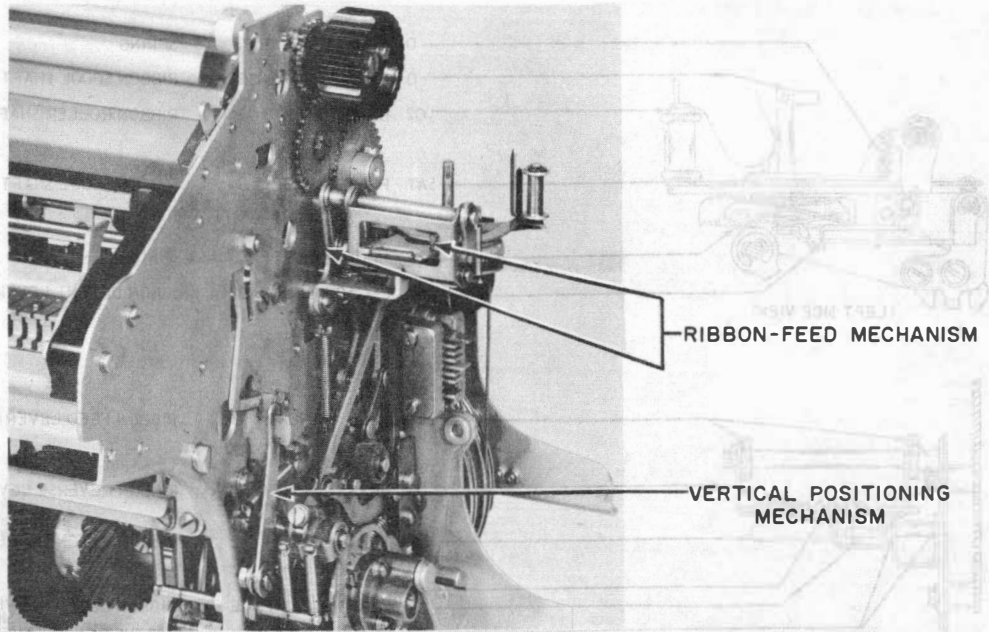

RIBBON-FEED MECHANISM

VERTICAL POSITIONING MECHANISM

28 TYPING
UNIT
LUBRI-
CATION

P34.501

Page 27

2.25 Ribbon-feed Mechanism

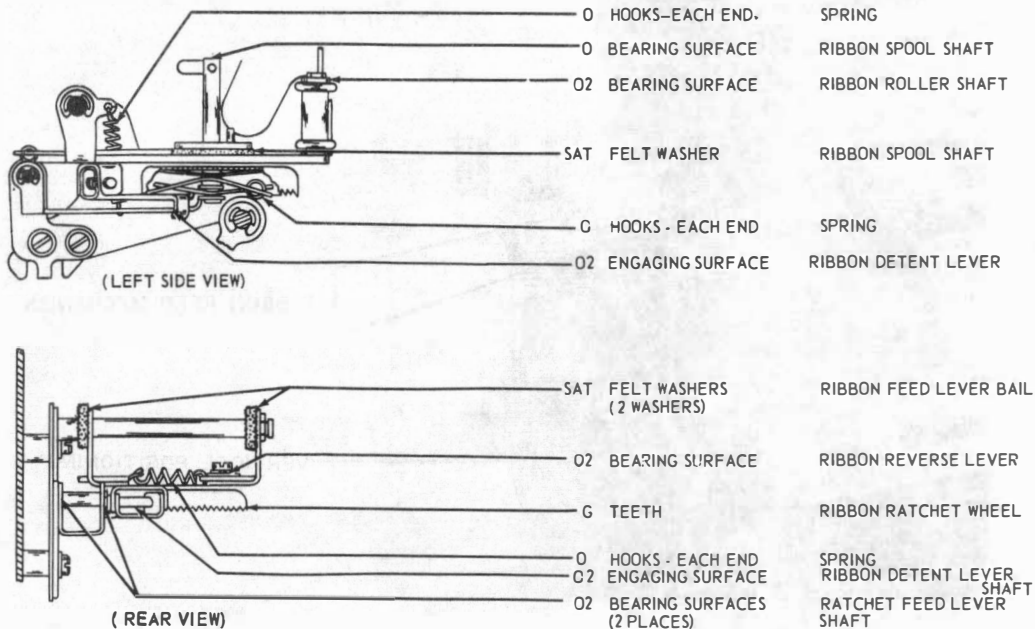

2.26 Ribbon-feed Mechanism (Contd)

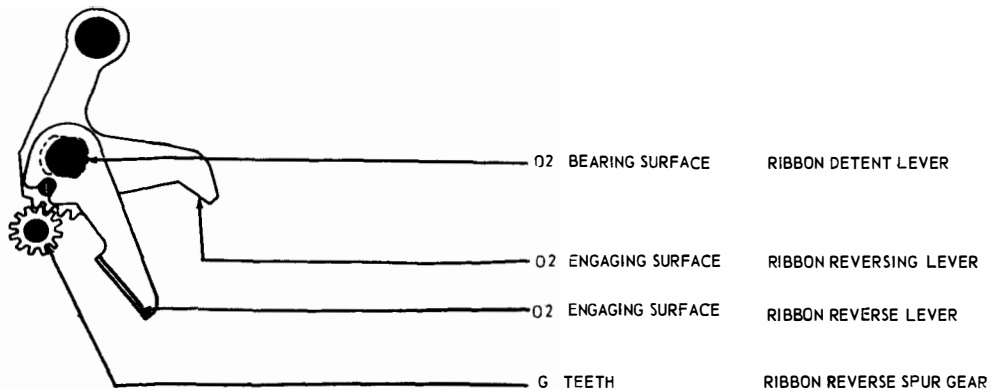

2.27 Vertical Positioning Mechanism

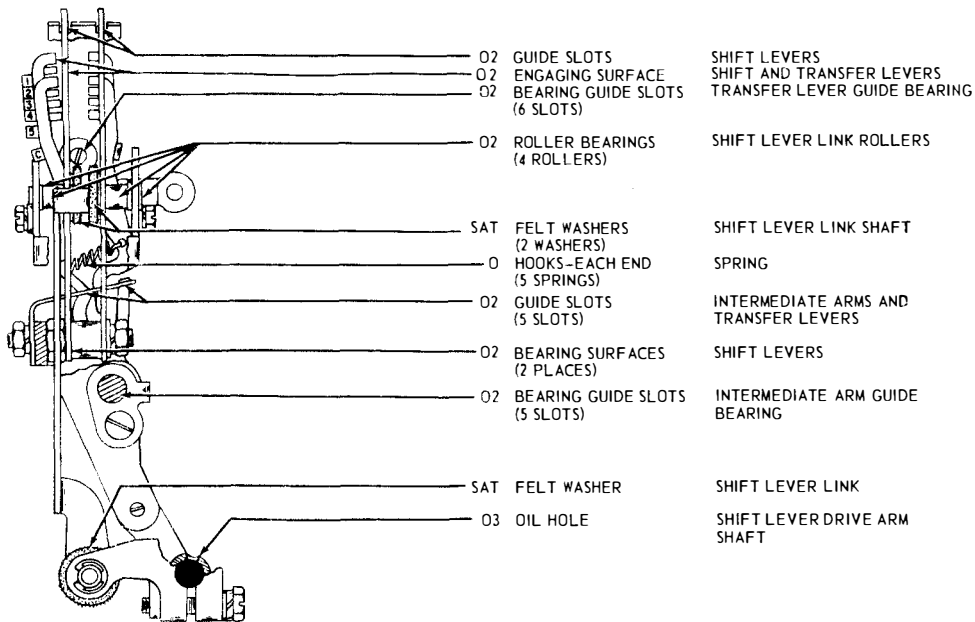

2.28 Codebar Mechanism (Left Side)

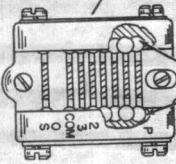
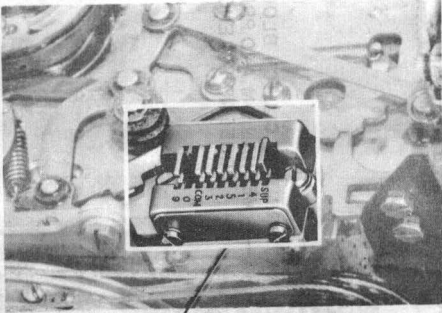

02 BEARING BALLS
(9 BALLS)
CODE BAR DETENT

2.29 Printing Clutch Blocking Mechanism and Print Codebar Solenoid (Left Side)

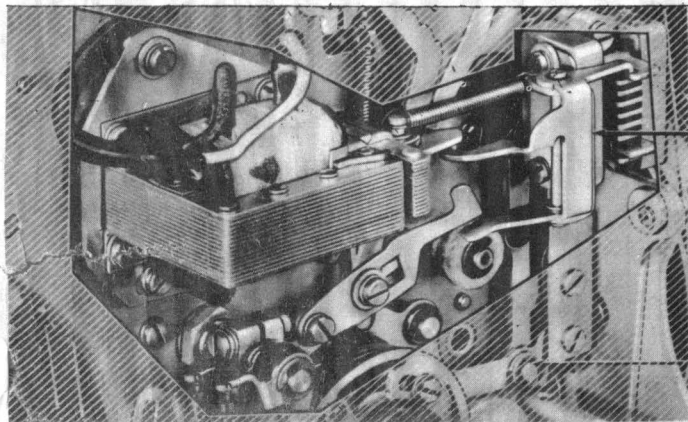

**PRINTING CLUTCH BLOCKING
MECHANISM AND PRINT
CODEBAR SOLENOID**

2.30 Printing Clutch Blocking Mechanism and Print Codebar Solenoid

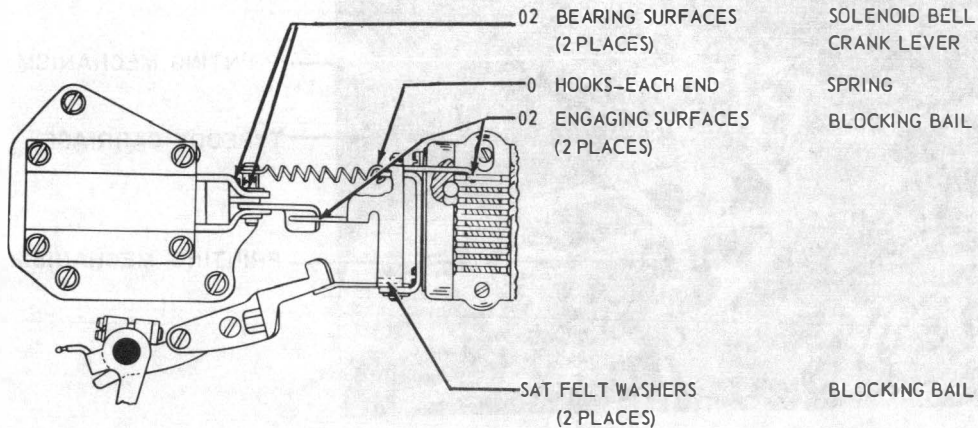

2.31 Printing Mechanism and Typebox Carriage

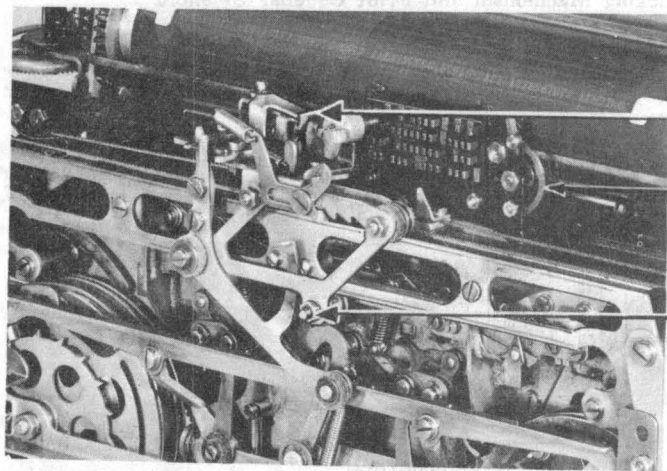

PRINTING MECHANISM

TYPEBOX CARRIAGE

PRINTING MECHANISM

2.32 Printing Mechanism

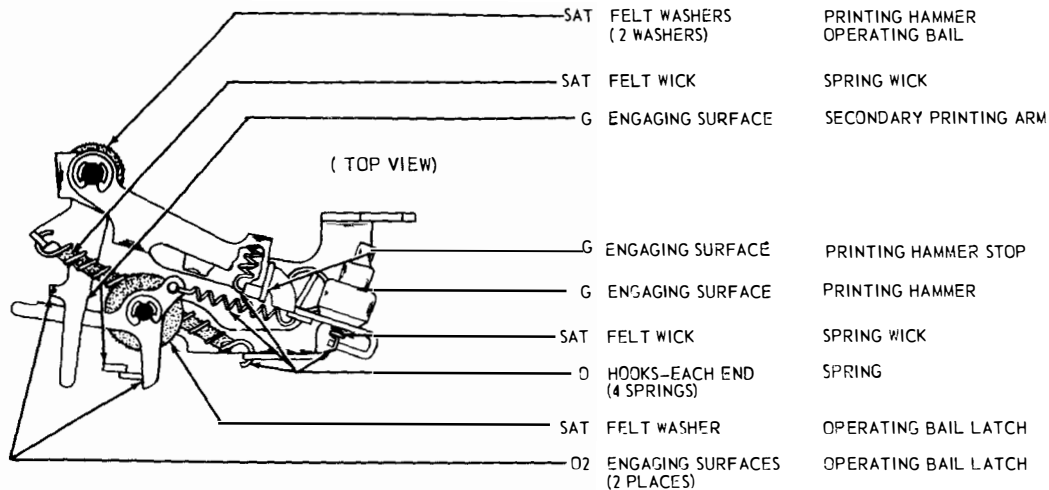

28 TYPING
UNIT
LUBRI-
CATION

P34.501

Page 35

2.33 Printing Mechanism (Contd)

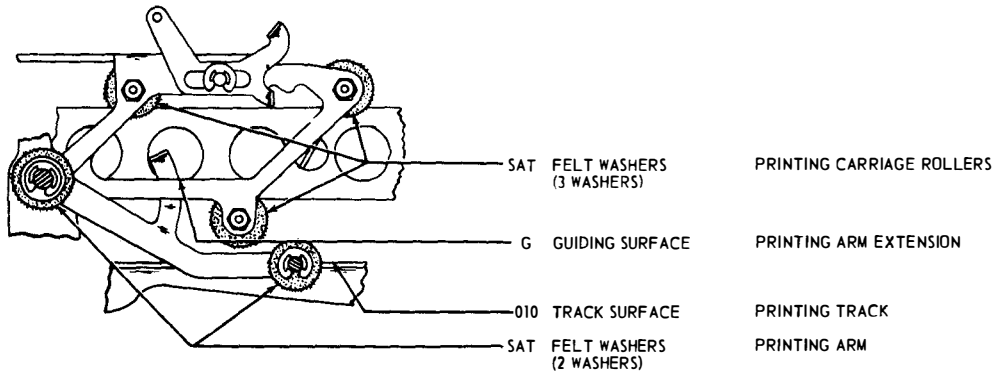

2.34 Typebox Carriage

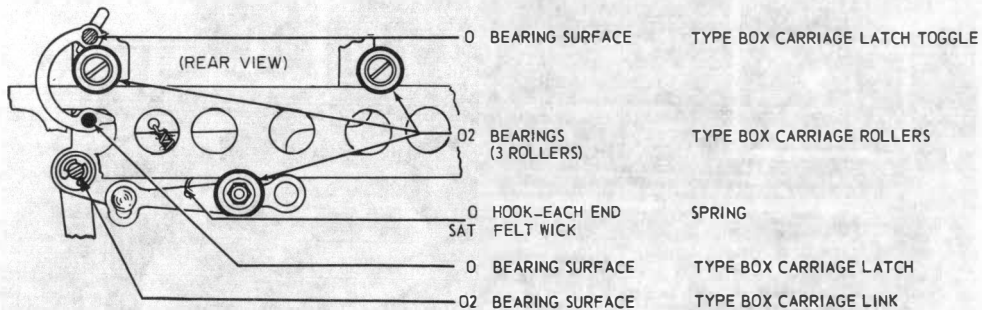

28 TYPING
UNIT
LUBRI-
CATION

2.35 Paper-feed and Codebar Mechanisms

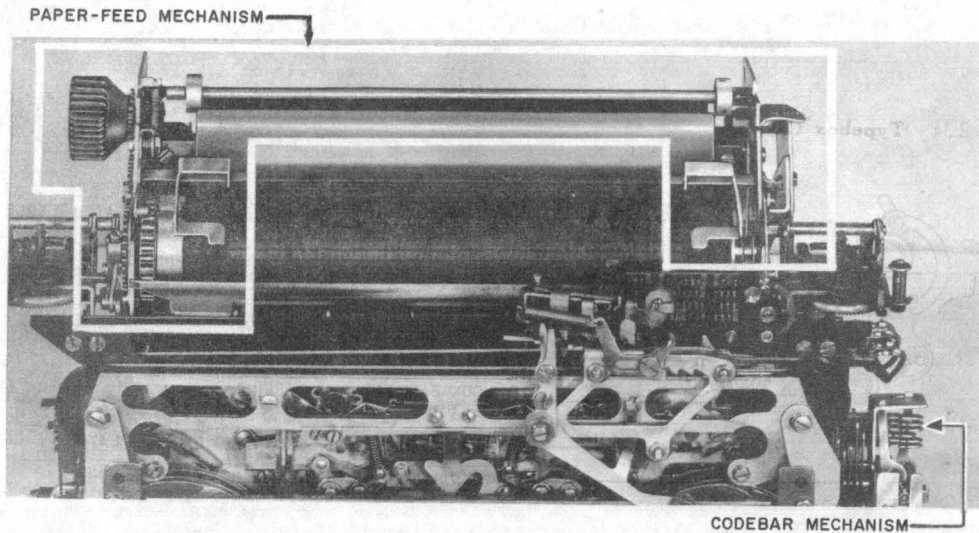

2.36 Paper-feed Mechanism

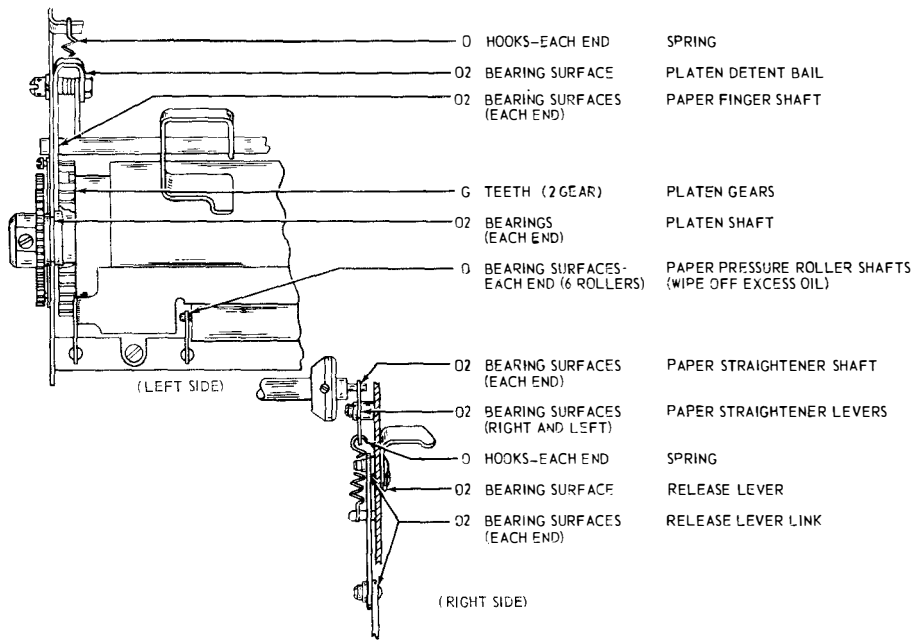

2.37 Codebar Mechanism

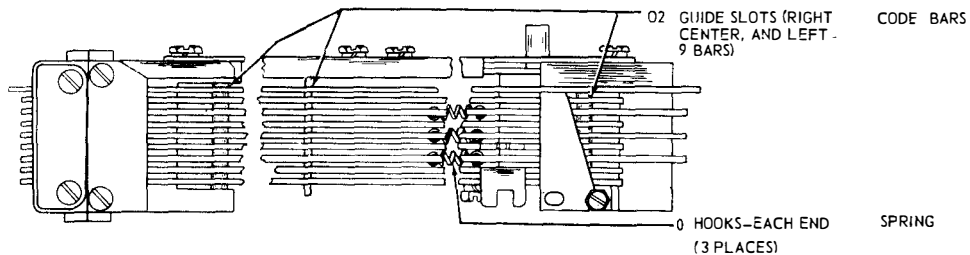

2.38 FIGS-LTRS Shift and Oscillating Mechanisms

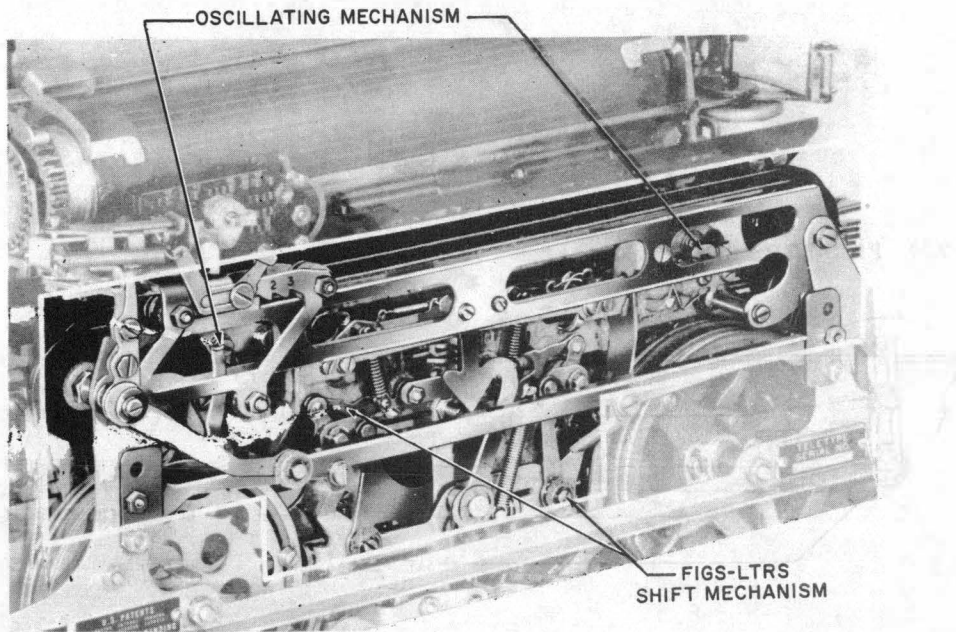

28 TYPING
UNIT
LUBRI-
CATION

P34.501

Page 41

FIGS-LTRS Shift Mechanism

SECTIONAL VIEW

2.39 FIGS-LTRS Shift Mechanism

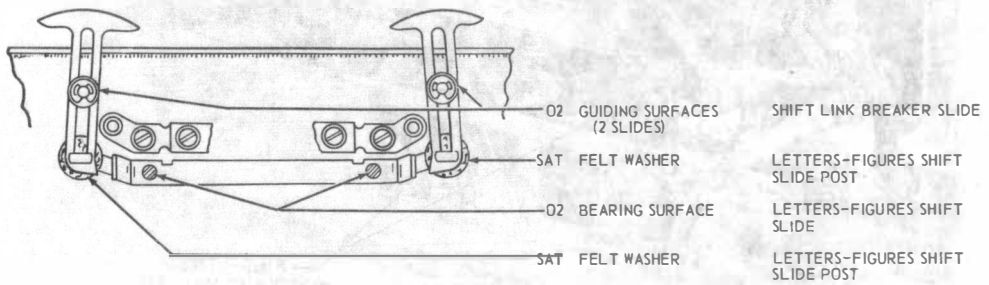

4-485C-42

2.40 FIGS-LTRS Shift Mechanism (Contd)

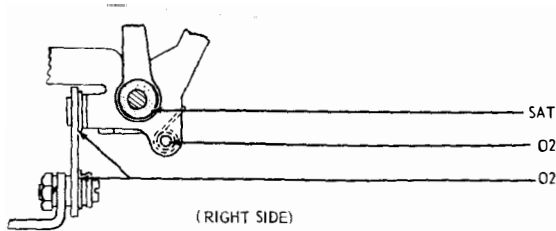

SAT FELT WASHER
 O2 BEARING SURFACE
 O2 BEARING SURFACES
 (2 PLACES)

SHIFT SLIDE DRIVE LINK
 BREAKER SLIDE BAIL
 MAIN BAIL LINK

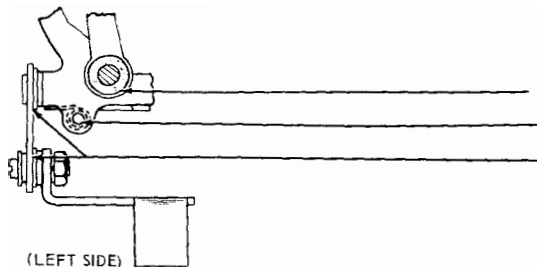

SAT FELT WASHER
 O2 BEARING SURFACE
 O2 BEARING SURFACES
 (2 PLACES)

SHIFT SLIDE DRIVE LINK
 BREAKER SLIDE BAIL
 MAIN BAIL LINK

28 TYPING
 UNIT
 LUBRI-
 CATION

P34.501

Page 43

2.41 Oscillating Mechanism

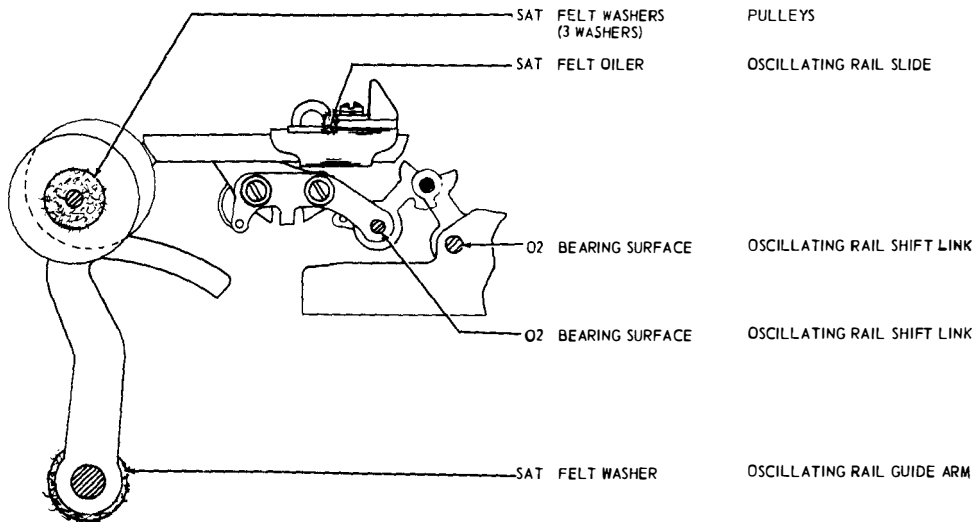

2.42 Oscillating Mechanism (Contd)

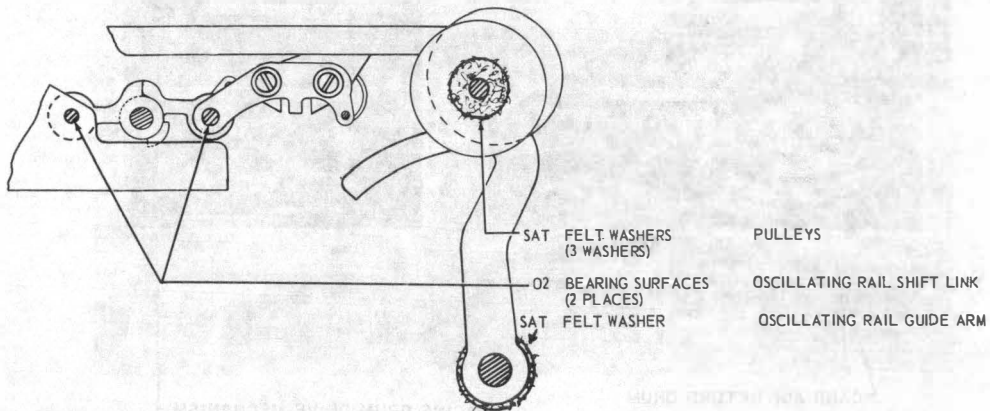

28 TYPING
UNIT
LUBRI-
CATION

P34.501

Page 45

Note: The typing unit should be on its back for lubrication shown in 2.43 to 2.51, inclusive.

2.43 Spacing Drum Release, Printing Track Guide, Carriage Return Drum, and Spacing Drum Drive Mechanisms

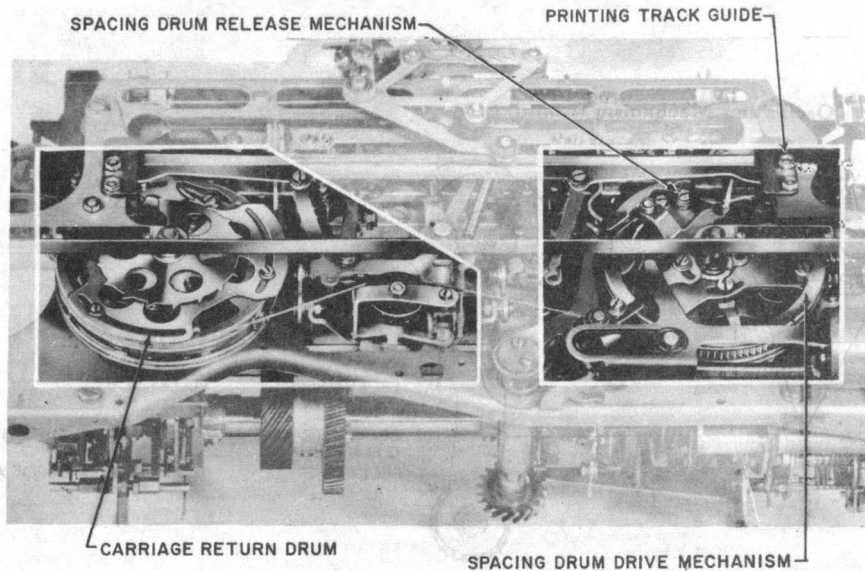

2.44 Spacing Drum Release Mechanism

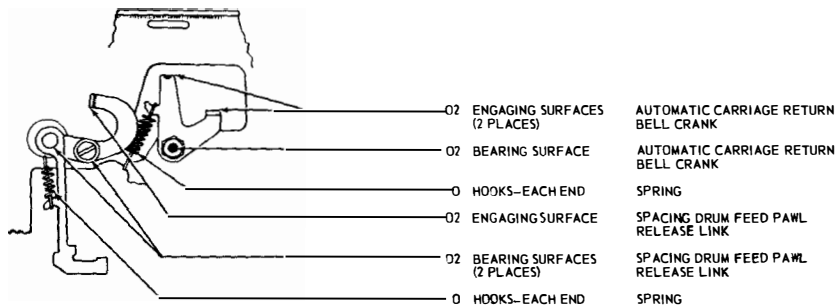

2.45 Printing Track Guide

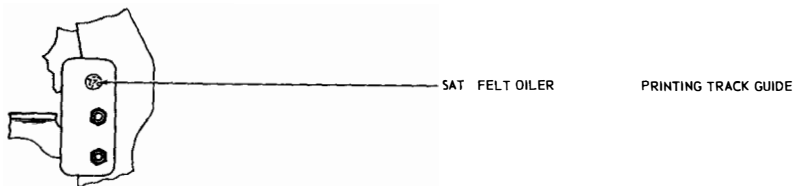

28 TYPING
UNIT
LUBRI-
CATION

P34.501

Page 47

2.46 Carriage Return Drum

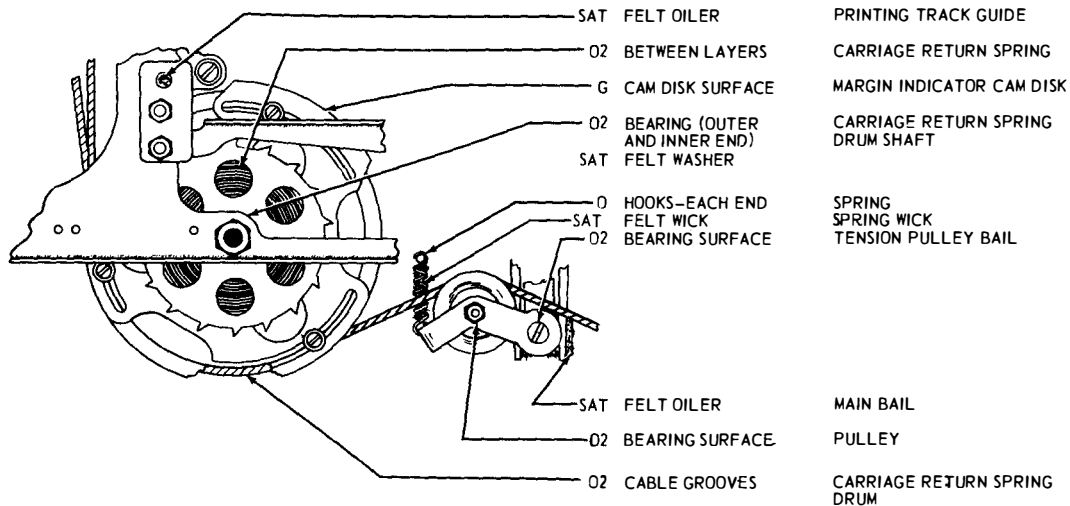

2.47 Spacing Drum Drive Mechanism

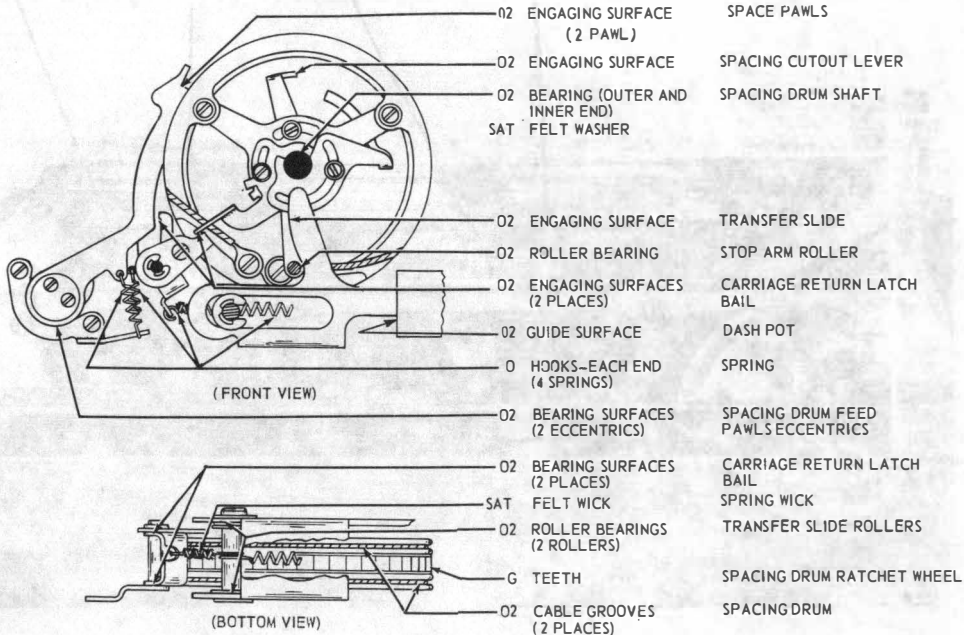

28 TYPING
UNIT
LUBRI-
CATION

P34.501

Page 49

2.48 Horizontal Positioning Mechanism

HORIZONTAL POSITIONING MECHANISM

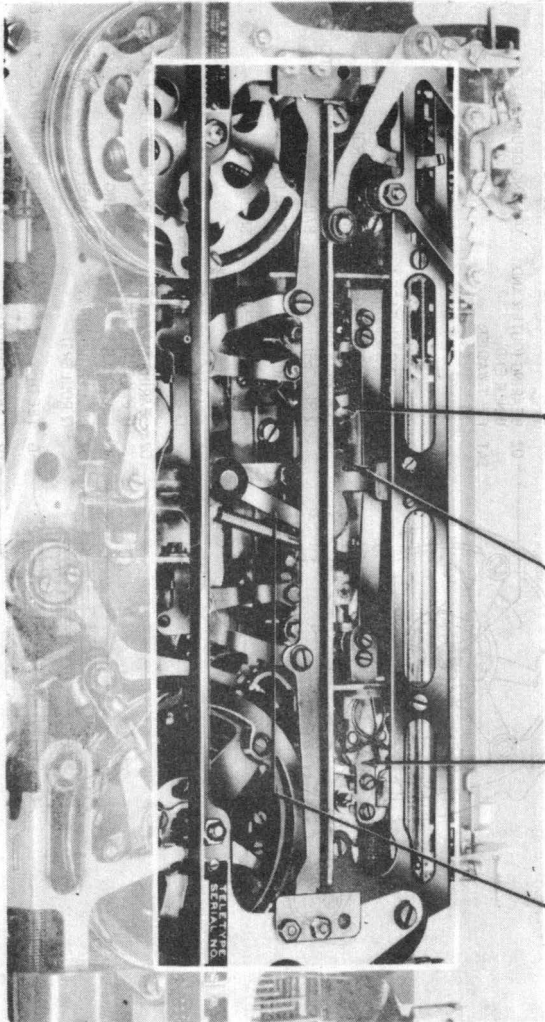

2.49 Horizontal Positioning Mechanism (Contd)

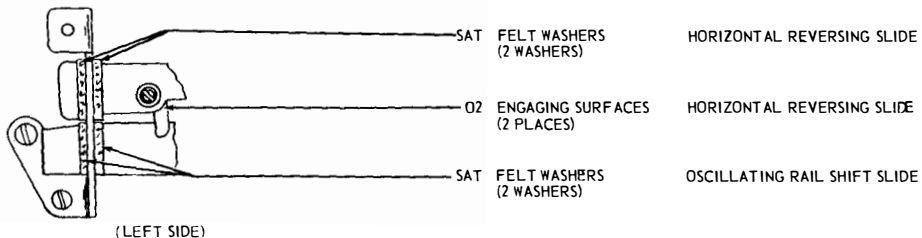
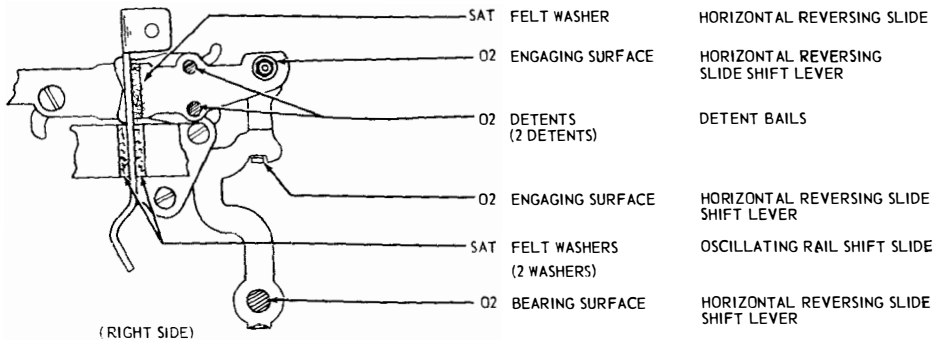

2.50 Horizontal Positioning Mechanism (Contd)

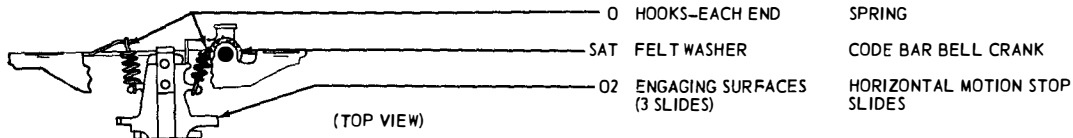

NOTES

1. WITH SPRINGS LOCATED ON REAR SIDE OF SLIDE
2. WITH SPRINGS LOCATED ABOVE THE SLIDE

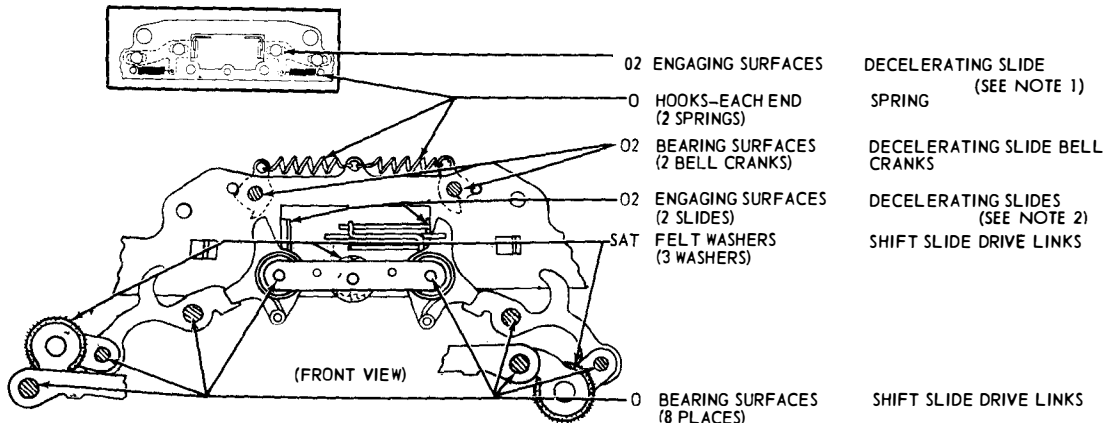

2.51 Horizontal Positioning Mechanism (Contd)

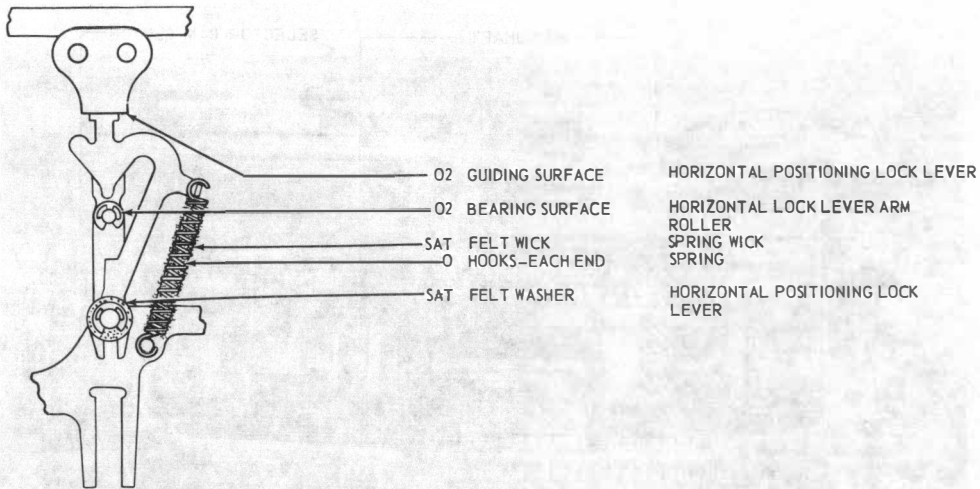

28 TYPING
UNIT
LUBRI-
CATION

P34.501

Page 53

Note: The typing unit should be bottom upward for lubrication shown in 2.52 to 2.60, inclusive.

2.52 **Mainshaft**

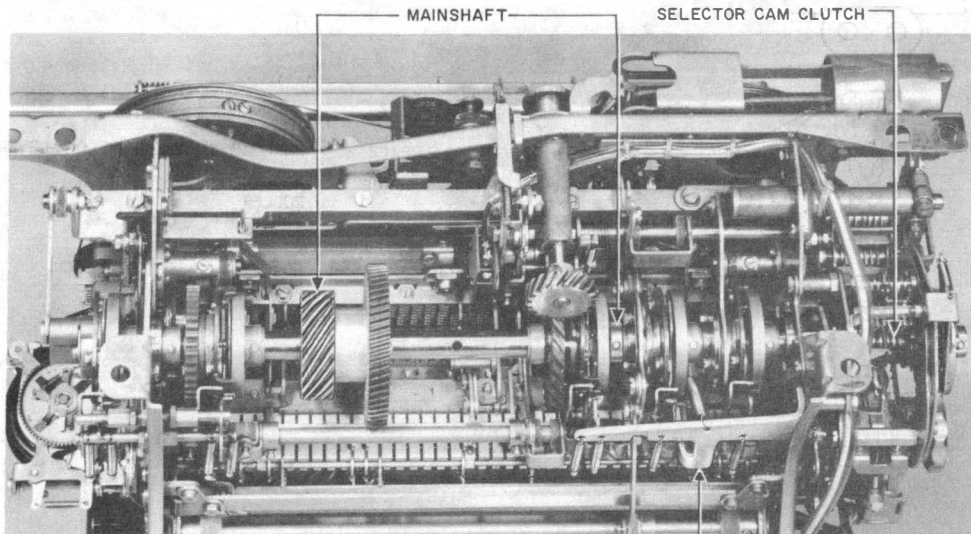

CLUTCH TRIPLEVERS AND CAMFOLLOWERS

2.53 Mainshaft (Contd)

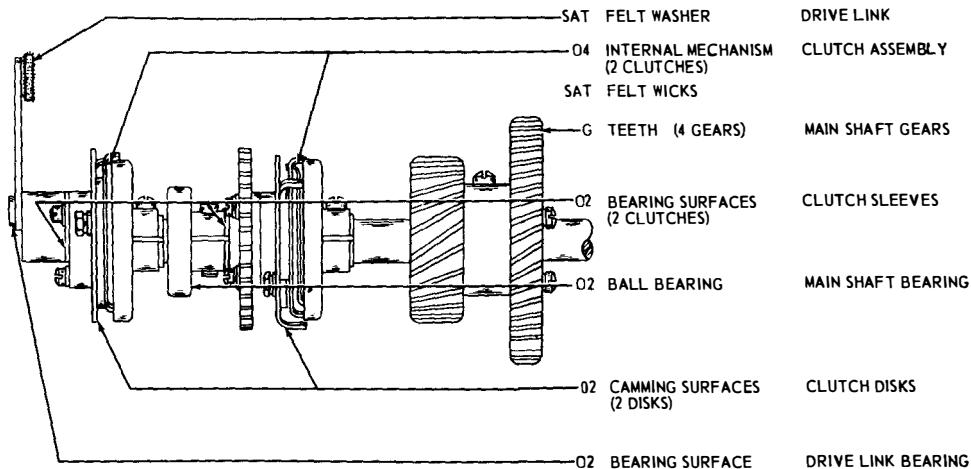

28 TYPING
UNIT
LUBRI-
CATION

P34.501

Page 55

2.54 Mainshaft (Contd)

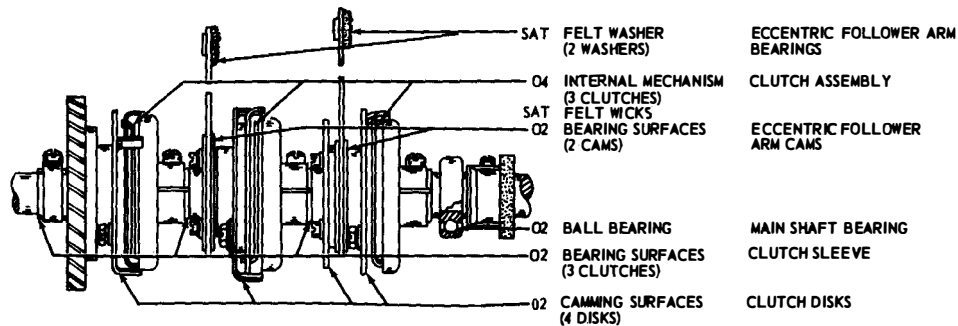

2.55 Selector Cam Clutch

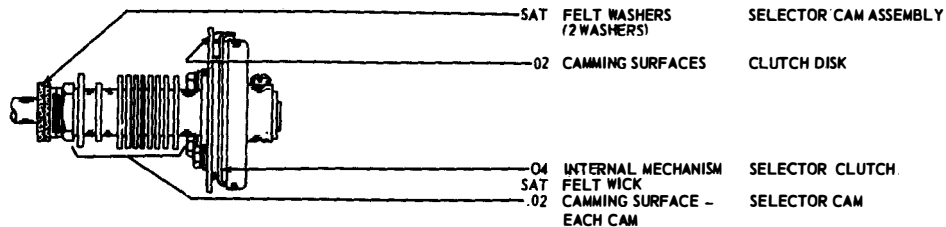

2.56 Clutch Triplevers and Camfollowers

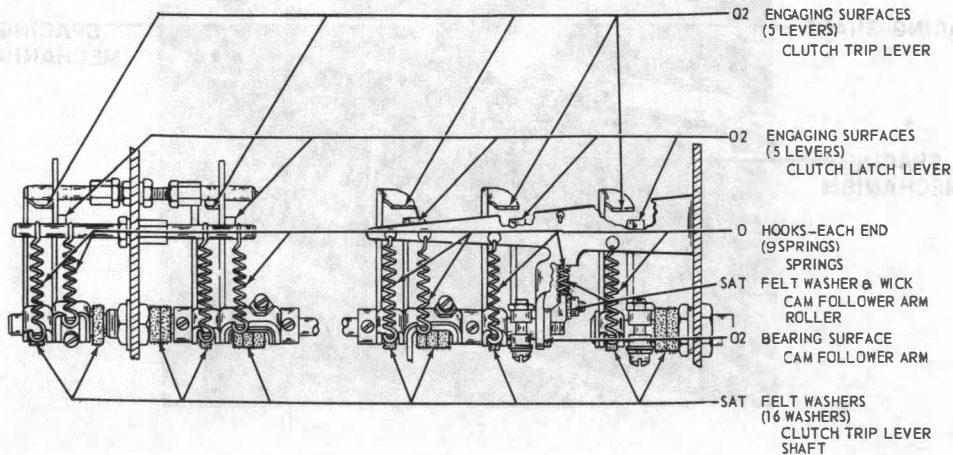

28 TYPING
UNIT
LUBRI-
CATION

P34.501

Page 57

2.57 Spacing Mechanism

SPACING SHAFT

SPACING
MECHANISM

SPACING
MECHANISM

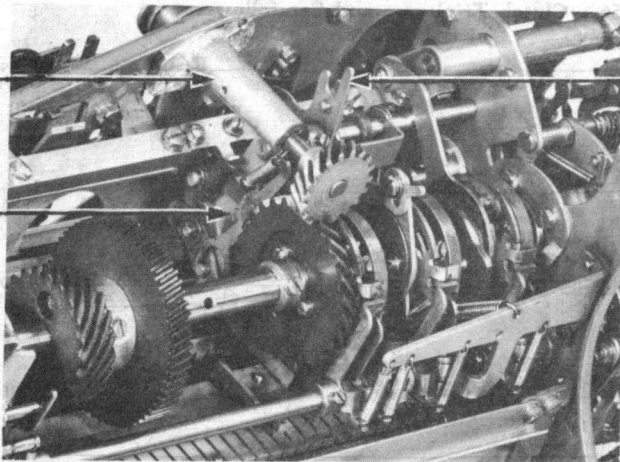

2.58 Spacing Shaft

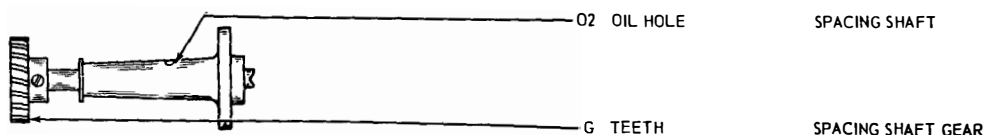

2.59 Spacing Mechanism

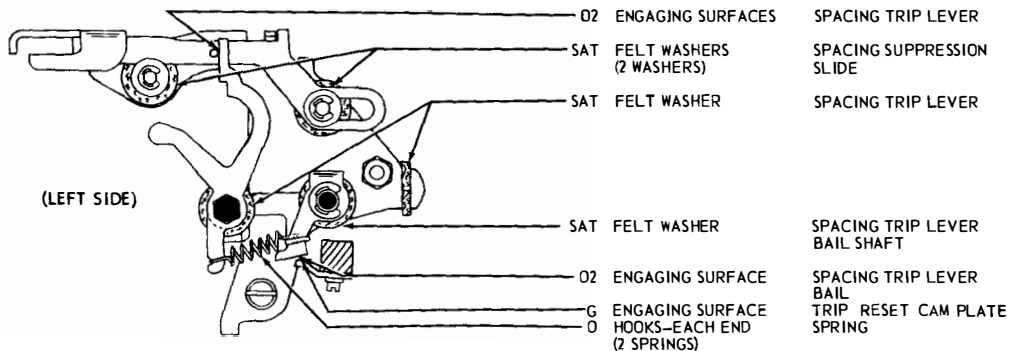

2.60 Spacing Mechanism (Contd)

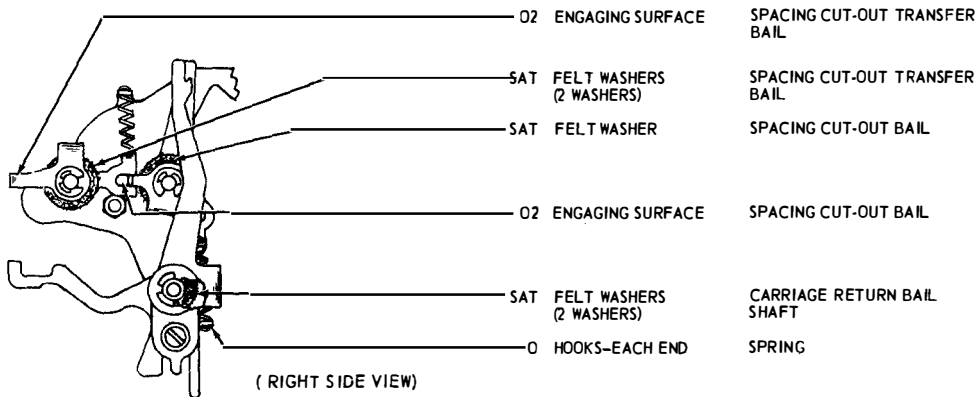

2.61 Sprocket-feed Mechanism (Rear)

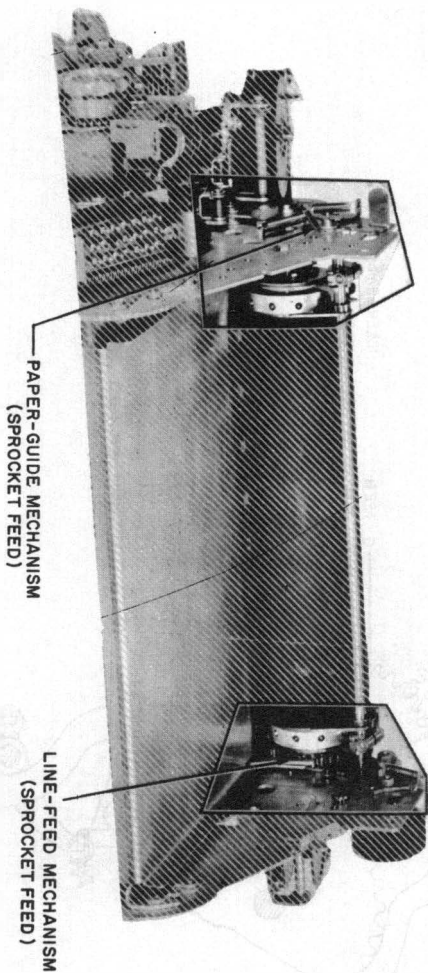

28 TYPING
UNIT
LUBRI-
CATION

P34.501

Page 61

2.62 Sprocket Feed—Line-feed Mechanism

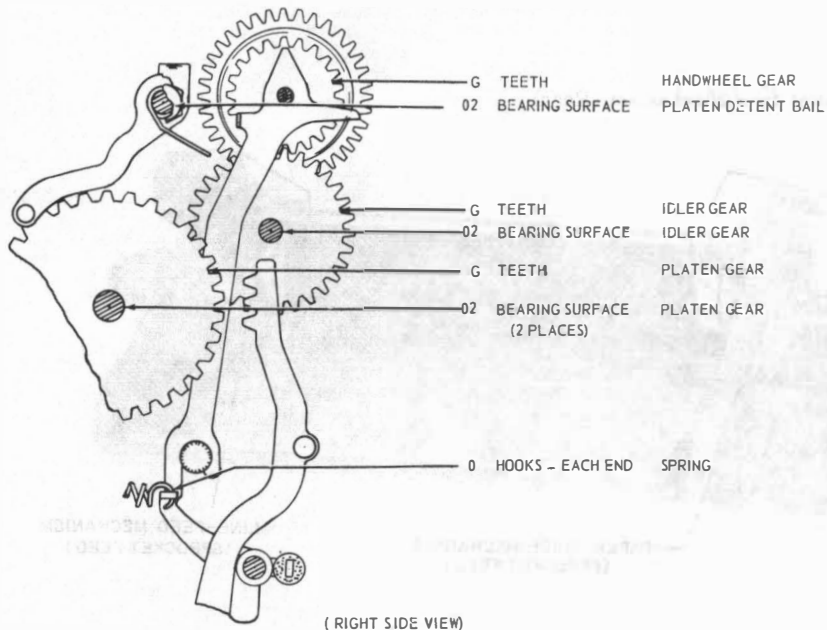

2.63 Sprocket Feed—Paper-guide Mechanism

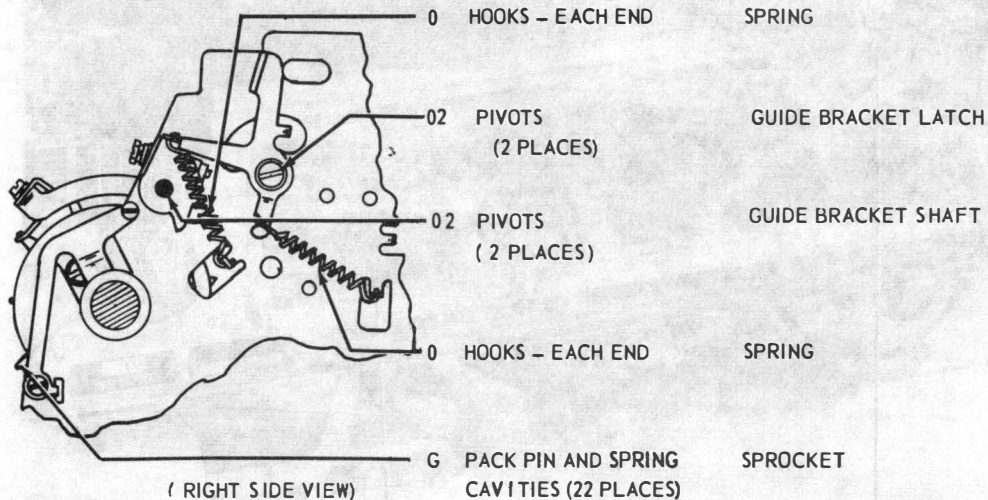

28 TYPING
UNIT
LUBRI-
CATION

P34.501

Page 63

2.64 Universal Drum (Later Design) and Horizontal Tabulator (Earlier Design)

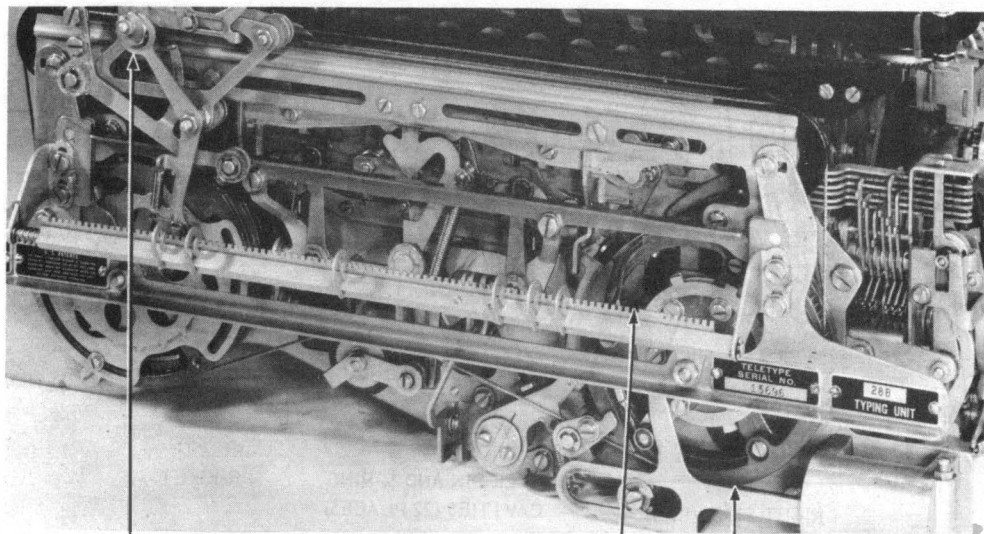

TABULATOR SHAFT

SPACE SUPPRESSION MECHANISM

UNIVERSAL DRUM

2.65 Universal Drum (Later Design)

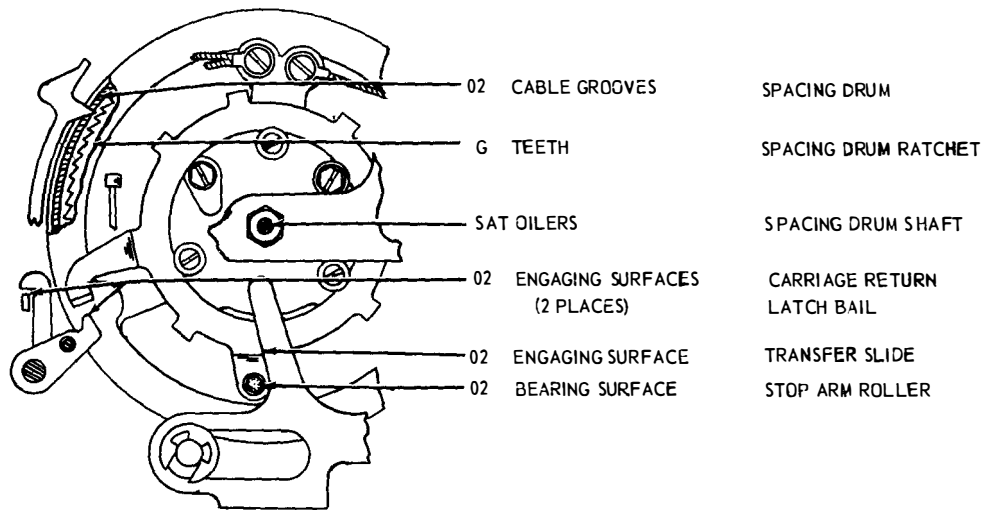

2.66 Horizontal Tabulator—Tabulator Shaft Mechanism (Earlier Design)

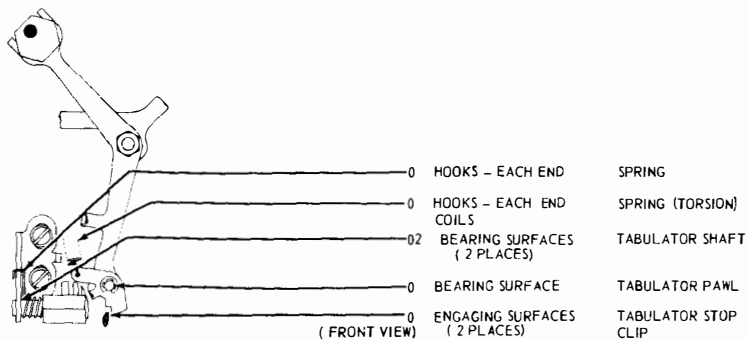

2.67 Horizontal Tabulator—Space Suppression Mechanism (Earlier Design)

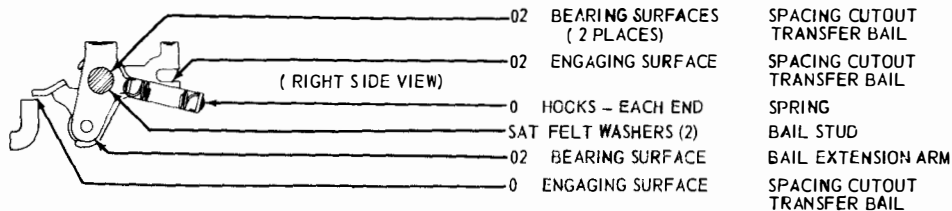

Note: The typing unit should be bottom upward for lubrication shown in 2.68 to 2.70, inclusive.

2.68 **Horizontal Tabulator (Earlier Design)**

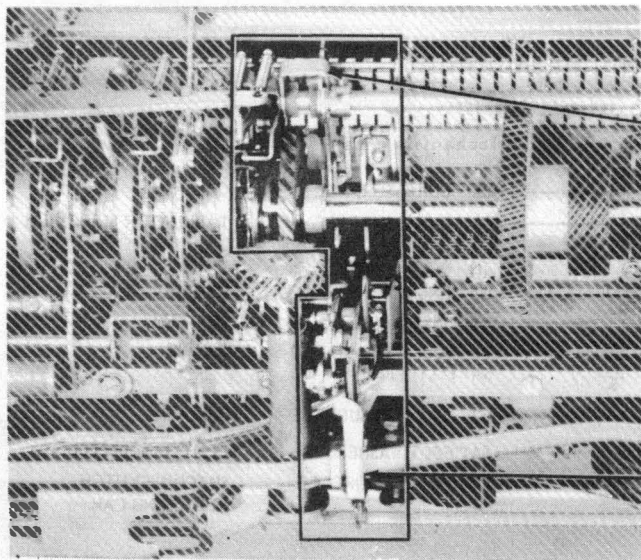

SPACING CLUTCH
MECHANISM

OPERATING LEVER
MECHANISM

28 TYPING
UNIT
LUBRI-
CATION

P34.501

Page 67

2.69 **Horizontal Tabulator—Space Clutch Mechanism (Earlier Design)**

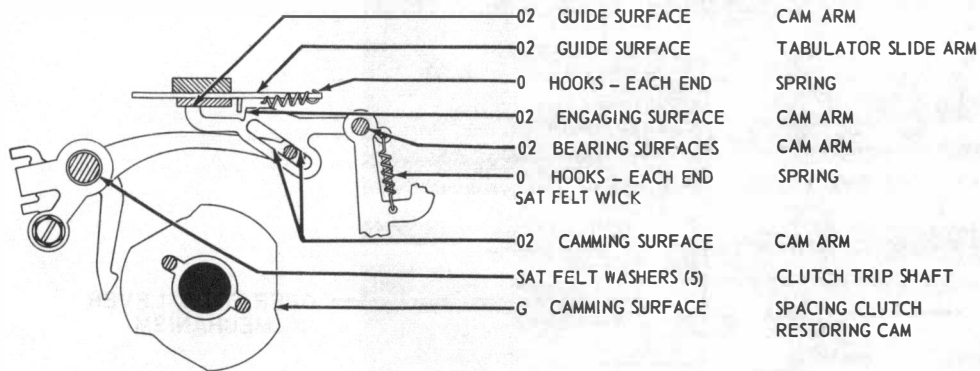

2.70 Horizontal Tabulator—Operating Lever Mechanism (Earlier Design)

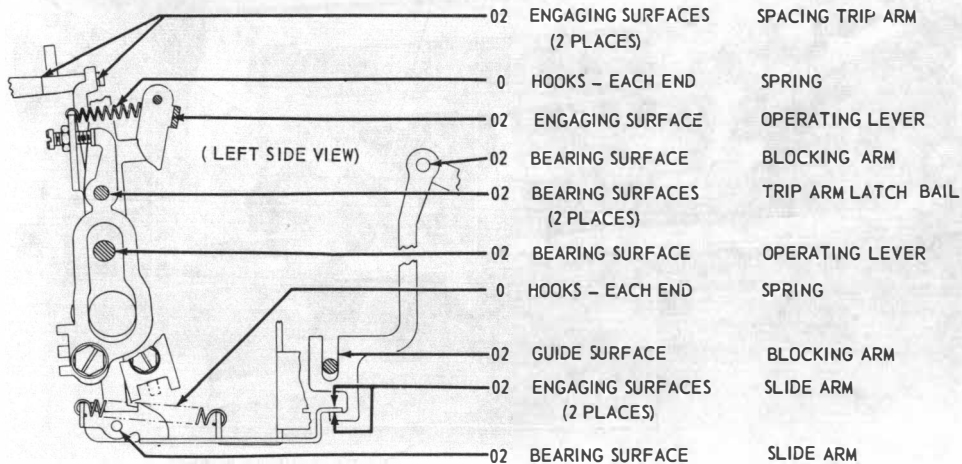

28 TYPING
UNIT
LUBRI-
CATION

P34.501

Page 69

2.71 Horizontal Tabulator (Later Design)

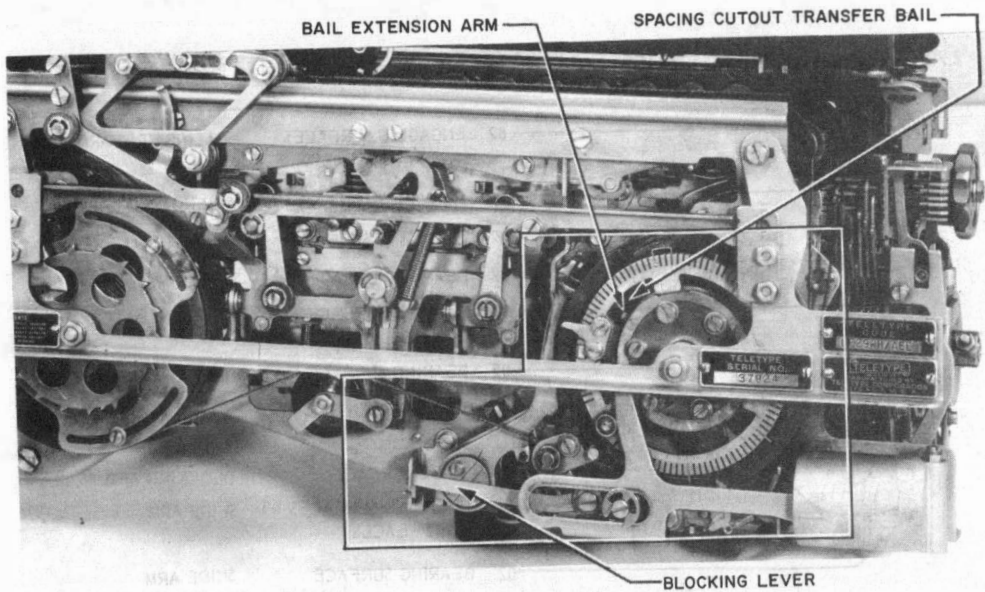

2.72 Horizontal Tabulator—Blocking Lever (Later Design)

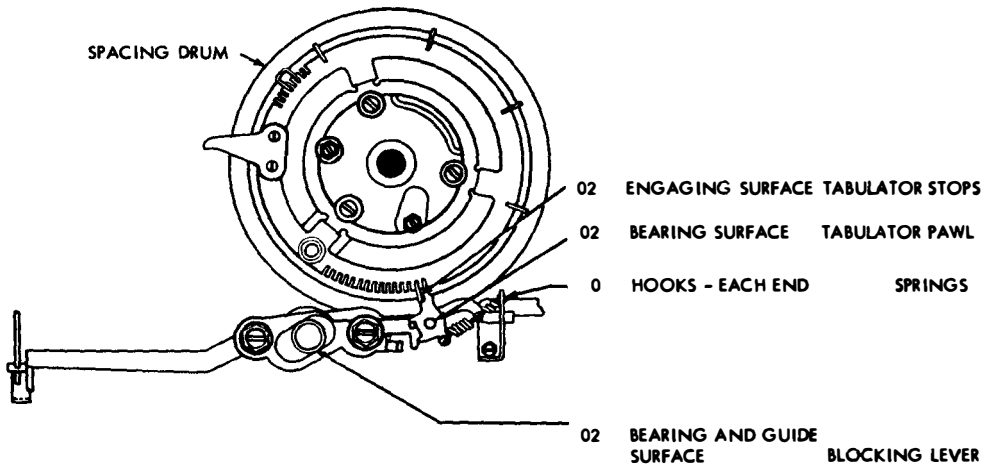

28 TYPING
UNIT
LUBRI-
CATION

P34.501

Page 71

2.73 Horizontal Tabulator—Spacing Cutout Transfer Bail (Later Design)

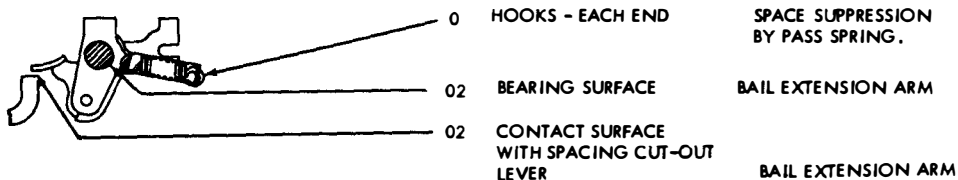

2.74 Horizontal Tabulator—Bail Extension Arm (Later Design)

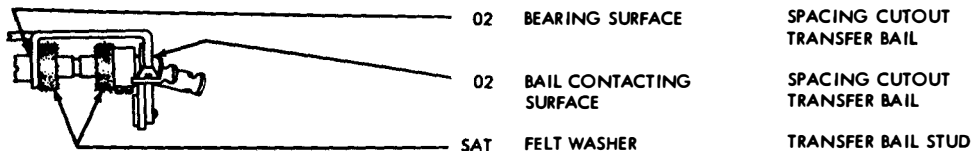

Note: The typing unit should be bottom up for 2.75 to 2.80.

2.75 Horizontal Tabulator (Later Design)

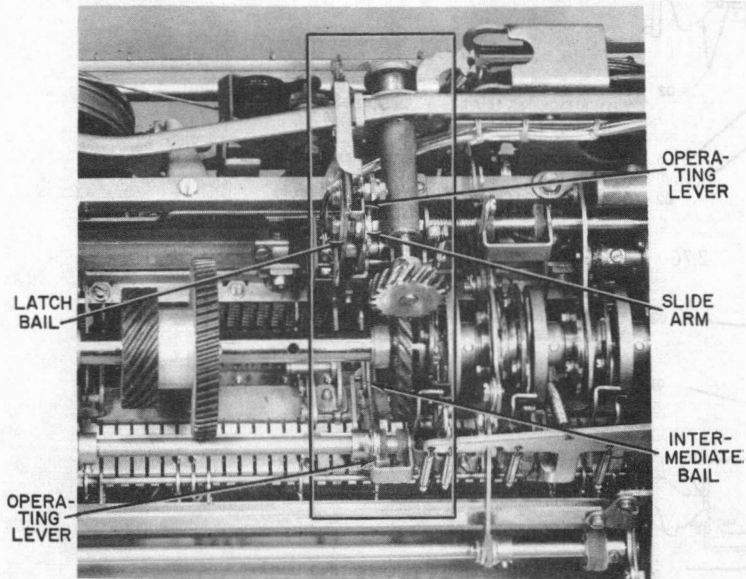

28 TYPING
UNIT
LUBRI-
CATION

P34.501

Page 73

2.76 Horizontal Tabulator—Slide Arm (Later Design)

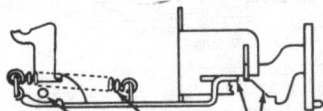

- | | | |
|----|--|------------------------------|
| 02 | ENGAGING SURFACE
WITH BLOCKING LEVER
AND BRACKET | OPERATING LEVER
SLIDE ARM |
| 0 | HOOKS - EACH END | SLIDE ARM SPRING |
| 02 | BEARING SURFACE | OPERATING LEVER
SLIDE ARM |

2.76 Horizontal Tabulator—
Operating Lever (Later Design)

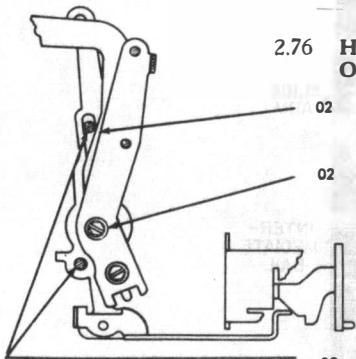

- | | | |
|----|--|------------------------------|
| 02 | CONTACTING SURFACE
WITH ADJUSTING PLATE | OPERATING LEVER |
| 02 | BEARING SURFACE | TRIP LEVER ARM
LATCH BAIL |
| 02 | BEARING SURFACE | OPERATING LEVER |

2.78 Horizontal Tabulator—Latch Bail (Later Design)

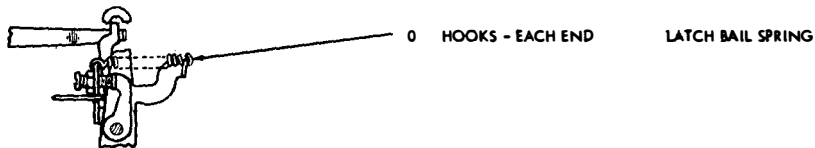

2.79 Horizontal Tabulator—
Operating Lever (Later
Design)

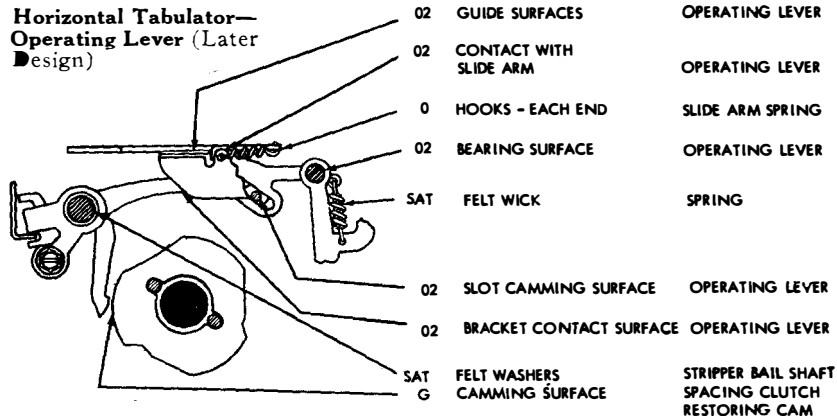

28 TYPING
UNIT
LUBRI-
CATION

P34.501

Page 75

2.80 **Horizontal Tabulator—Intermediate Bail (Later Design)**

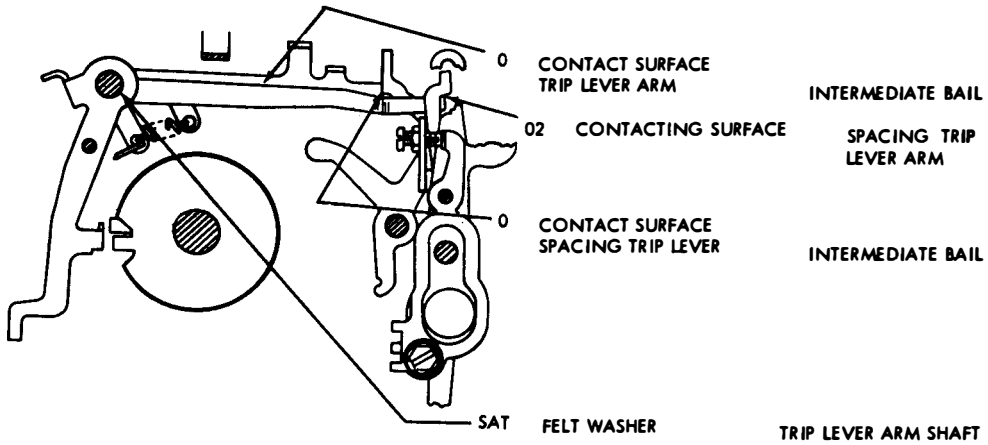

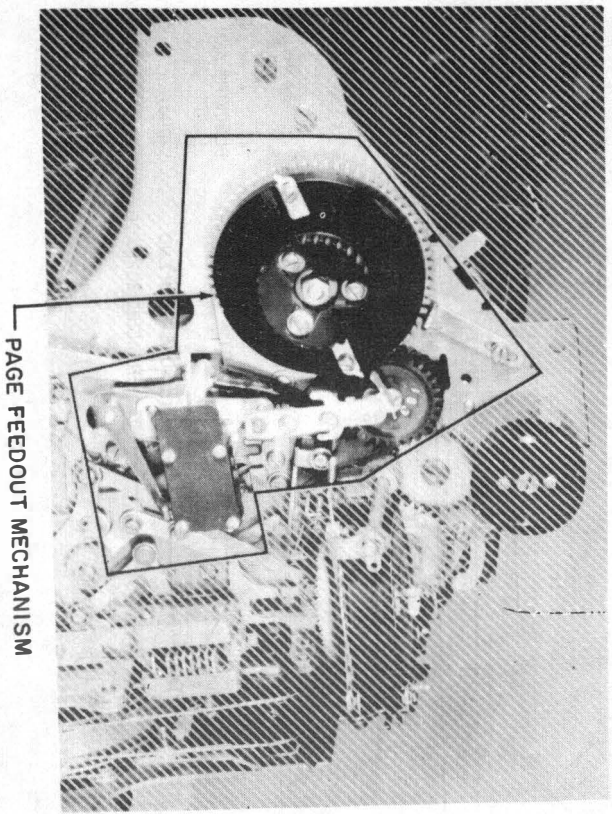

P34.501

Page 77

28 TYPING
UNIT
LUBRI-
CATION

2.82 Page Feedout Mechanism

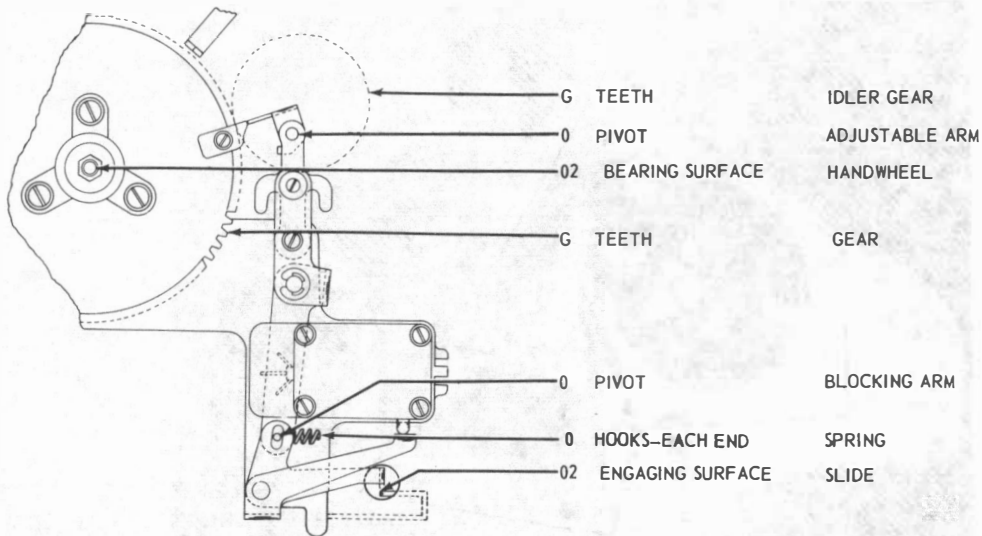

2.83 Paper-out Alarm Mechanism

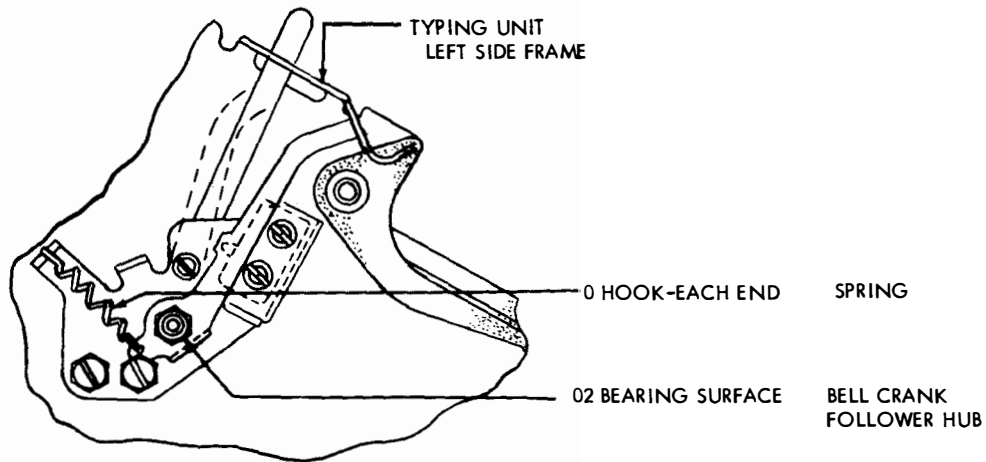

28 TYPING
UNIT
LUBRI-
CATION

2.84 Universal Contact Mechanism (Selector)

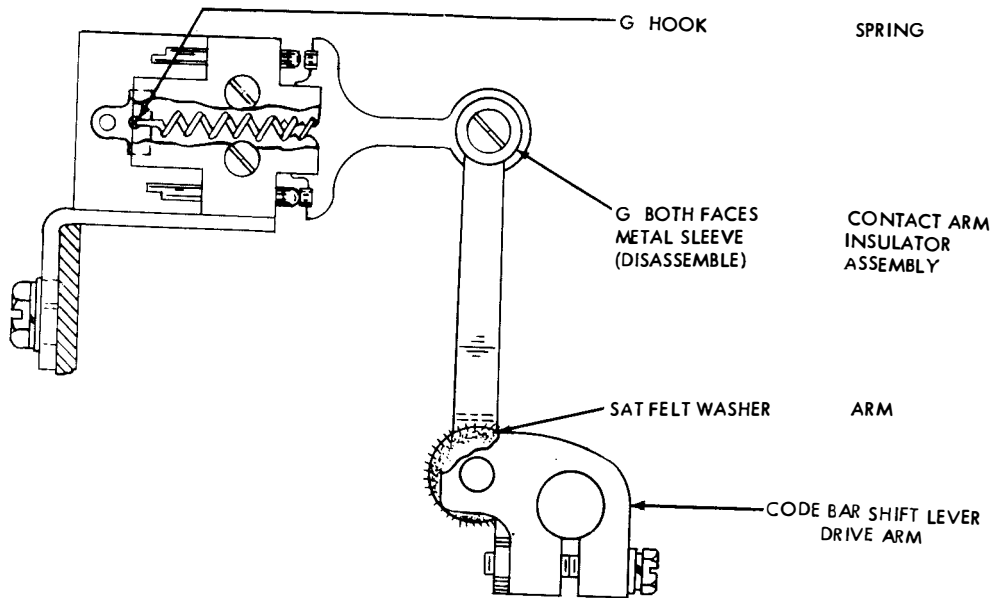

2.85 Universal Contact Mechanism (Stuntbox)

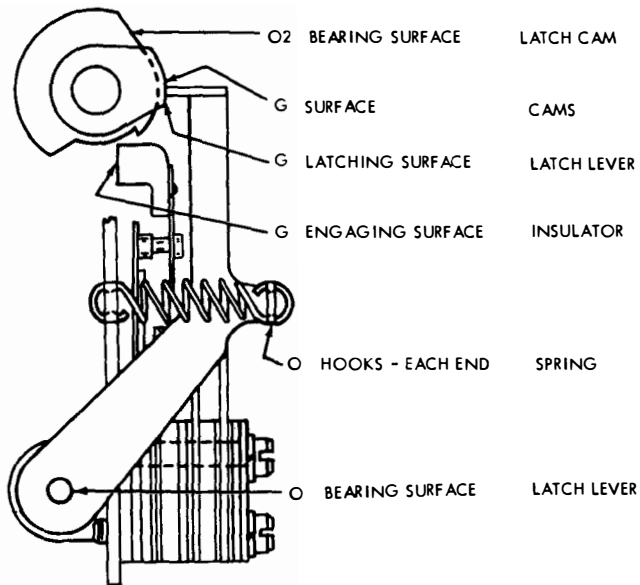

28 TYPING
 UNIT
 LUBRI-
 CATION

P34.501

Page 81

2.86 Form Feedout Mechanism (Local)

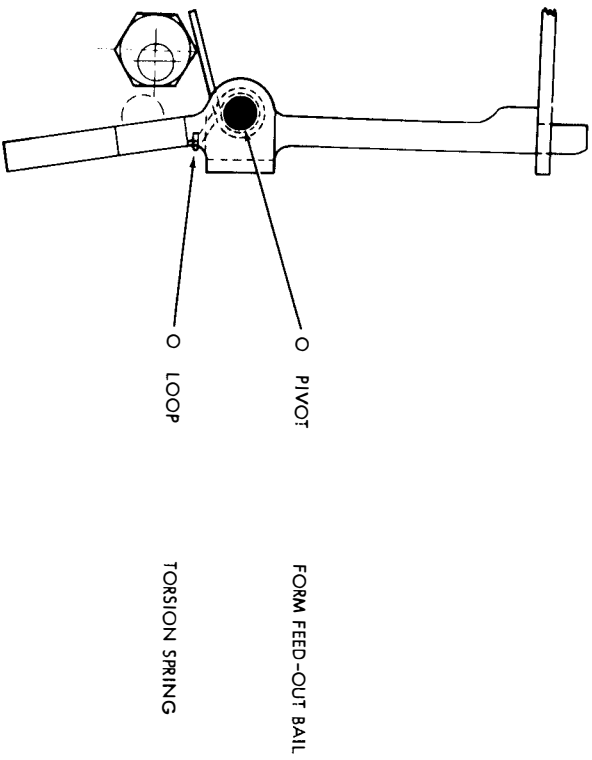

2.87 Print Suppression and Off-line Stunt Shift Control

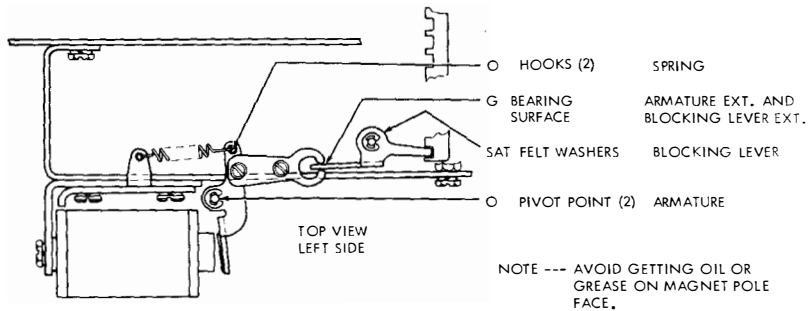

2.88 Vertical Tabulator

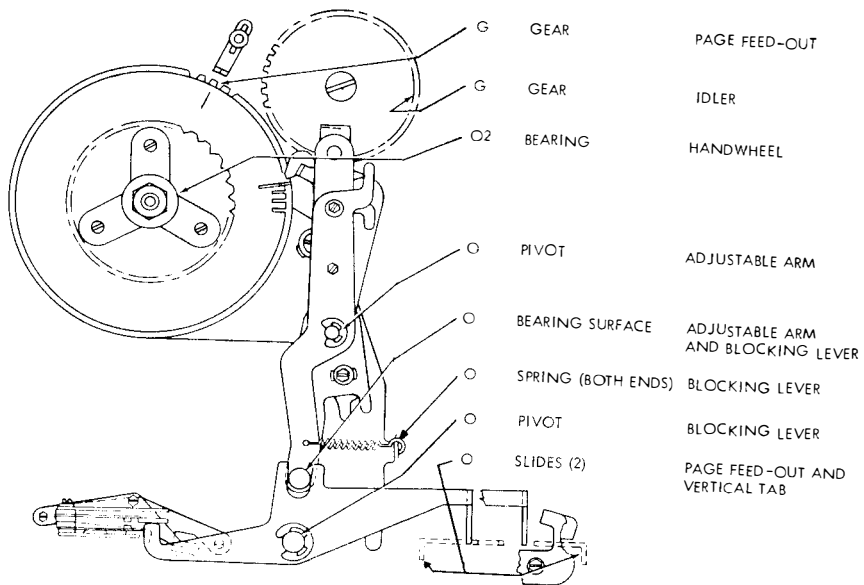

2.89 Parallel Code-reading Contacts

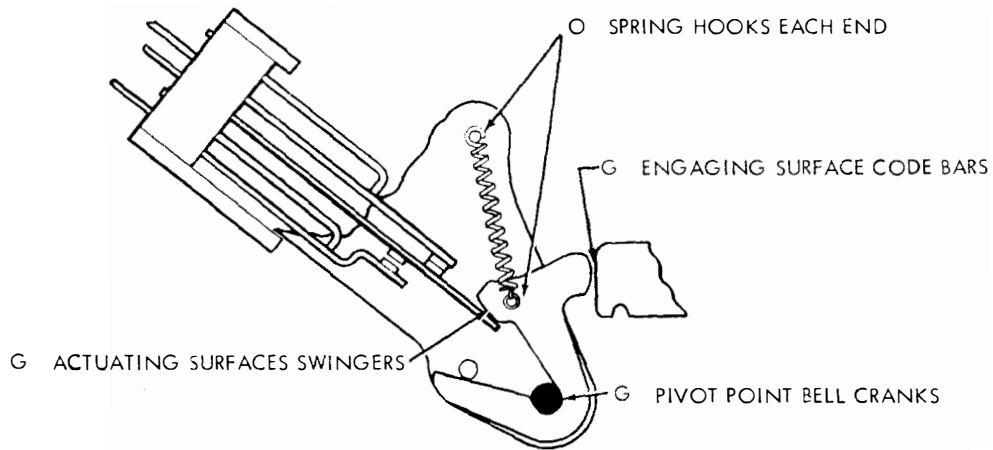

28 TYPING
UNIT
LUBRI-
CATION

P34.501

Page 85

3. ASSOCIATED BELL SYSTEM PRACTICES

3.01 The following Bell System Practice contains an index of information that may be related to this section.

Subject	Section
Alphabetical Index of 28-type Equipment, Bell System Practices, and Associated 28ASR Station Drawings	P34.001