

**BELL SYSTEM PRACTICES**  
**Teletypewriter and Data Stations**

**ADDENDUM P34.510**  
**Issue 1, January, 1962**  
**AT&TCo Standard**

## **28 DISTRIBUTOR**

### **LUBRICATION**

#### **1. GENERAL**

1.001 This addendum supplements Section P34.510, Issue 1.

1.002 This addendum is issued to add the specific lubrication procedures for the 28 distributor designed to operate at 60, 75, and 100 words per minute with provisions to accept 6-, 7-, and 8-level codes, and to revise the lubrication information in accordance with changes authorized for this apparatus by P98 series Bell System Practice listed at the end of the addendum.

The following change applies to Part 1 of the section:

(a) 1.02—revised

1.02 The distributor should be lubricated before being placed in service as specified in the section entitled Preparation of Teletypewriter Apparatus for Installation. After a few weeks in service, it should be relubricated to make certain that all the specified points have received lubricant. Thereafter, because of the varying conditions at each station, the distributor should be lubricated as often as specified by the local instructions. The following is suggested as a guide for use under normal operating conditions:

(a) Lubricate the distributor every 500 hours of operation or every six months, whichever occurs first.

#### **2. LUBRICATION**

The following changes apply to Part 2 of the section:

(a) 2.02—added note

(b) 2.07 through 2.10—added

##### **2.02 28 Distributor—Front**

**Note:** Where a unit has a cam sleeve assembly with an oil hole, lubricate the felt wick of the main shaft by applying oil through the oil hole. Where a unit has a cam sleeve assembly without an oil hole, remove the main shaft and apply oil to the felt wick.

## 2.07 Clutch-trip Magnet Mechanism

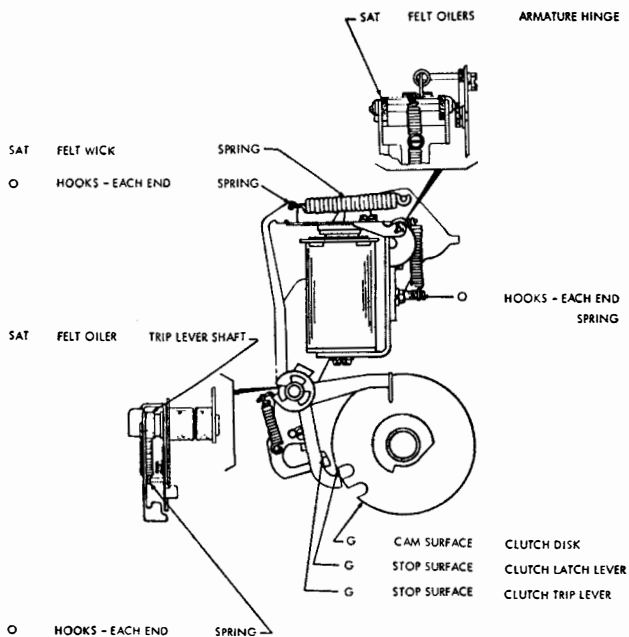

## 2.08 Contact Lever Assembly

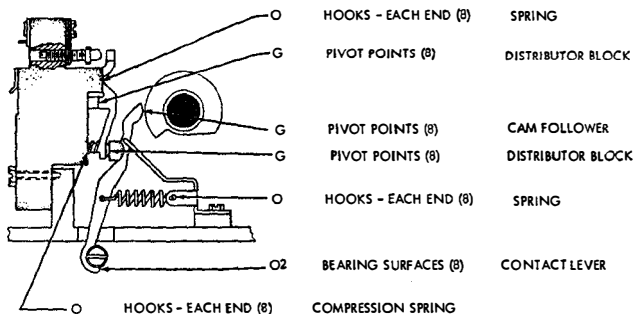

## 2.09 Cam Shaft and Clutch Assembly

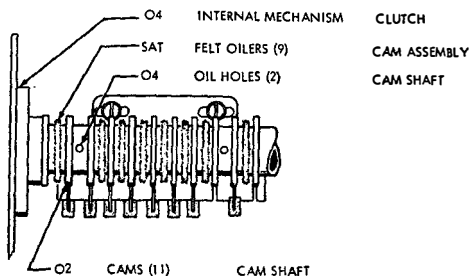

## 2.10 Base Gears

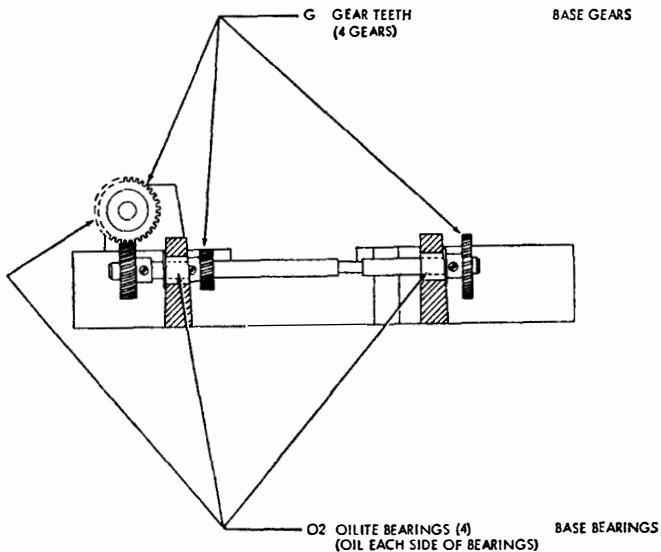

### CHANGES AUTHORIZED BY P98. SERIES BELL SYSTEM PRACTICE

<u>Par. No.</u>	<u>Lubrication Procedure</u>	<u>Includes Change as Authorized by Section</u>
1.02	Lubrication Interval	P98.814
2.02	Main Shaft	P98.814