

INSTALLATION INSTRUCTIONS FOR THE 179603 MODIFICATION  
KIT TO ADD TAPE WITHHOLD MECHANISM TO THE MODEL 28  
TRANSMITTER DISTRIBUTOR LXD

The Chart below pertains to Bell System only:

UNIT	TELETYPE CODE	BELL SYSTEM CODE
Transmitter Distributor	LXD3	28E
	LXD4	28H
	LXD26	28H5

Refer to standardized information for Adjustments, Lubrication and Wiring

## 1. GENERAL

a. The 179603 Modification Kit provides a tape withhold mechanism which allows the Model 28 Transmitter Distributor to generate a variable series of the same code combination upon receipt of an off-line control signal. Basically, the kit consists of a magnet, hardware for mounting it to the LXD center plate, and an armature which operates the feed pawl blocking bail. It will operate at speeds up to 100 WPM.

b. When the magnet is energized, the tape feed pawl is blocked and thereby permits continuous sensing and transmitting of the particular character over the sensing pins at the time of blocking. Initiation of the control signal will vary with the application of the tape withhold mechanism.

c. The 179603 Modification Kit consists of the following:

2	2191	Lock Washer	2	156399	Shoulder Nut
2	2669	Lock Washer	1	173974	Screw
2	3640	Lock Washer	1	179604	Magnet Assembly
1	90361	Felt Washer	1	179605	Pawl
2	150089	Screw	1	179606	Blocking Bail
1	151701	Torsion Spring	1	179607	Magnet Bracket
*2	151722	Screw	1	179660	Cable Assembly
2	156051	Eccentric Bushing			

d. For parts ordering information refer to Teletype Model 28 Transmitter Distributor Parts Bulletin 1161B.

## 2. INSTALLATION

a. Remove the LXD unit from its associated base in accordance with instructions in Teletype Bulletin 235B.

\*Indicates Change

Printed in U.S.A.

b. Feed Pawl

(1) Remove and retain the cover plate, top plate, and tape guide plate in accordance with instructions in Teletype Bulletin 235B.

(2) Remove the 156575 Shoulder Screw, 156576 Felt Washer, 3598 Nut, 2191 Lockwasher, 156578 Bail, and 76422 Spring. Retain the bail, shoulder screw, felt washer and spring; discard the nut and lockwasher.

(3) Remove the 3598 Nut and 2191 Lockwasher that secures the 156640 Post to the 160616 Center Plate. Discard the nut and lockwasher.

(4) Remove the 156521 Shoulder Screw, 3598 Nut, 2191 Lockwasher, 70388 Spring and 156522 Feed Pawl. Retain the shoulder screw, nut, lockwasher and spring; discard the feed pawl.

(5) Install the 179605 Feed Pawl using the retained hardware and spring.

c. Magnet Bracket and Magnet

(1) Install the 179607 Magnet Bracket to the 156640 Post using the 2669 Lockwasher against the magnet bracket and around the shoulder of the 156399 Shoulder Nut. Turn down the nut friction tight; make certain that the shoulder of the nut enters the hole in the bracket.

(2) Reinstall the 156578 Bail using the retained shoulder screw and felt washer. Position the magnet bracket so that its upper mounting hole will accept the threaded end of the shoulder screw. Secure the shoulder screw and magnet bracket with the 2669 Lockwasher and 156399 Shoulder Nut as in the previous step. Tighten both shoulder nuts securely.

\* (3) Secure the 179604 Magnet Assembly to the magnet bracket using two 151722 Screws and two 2191 Lockwashers.

NOTE

The magnet operates on 115 V DC  $\pm$  10% with a 1100 ohm series resistance, and 48 V DC  $\pm$  10% with no external resistance.

d. Blocking Bail Assembly

(1) Secure one of the 156051 Eccentric Bushings to the extruded hole in the 179606 Blocking Bail with a 150089 Screw and 3640 Lockwasher, (the hex portion of the eccentric is adjacent to the arm).

(2) Place a 90361 Felt Washer in the yoke of the blocking bail and center the washer by positioning it over the hole in that portion of the side of the bail that includes the arm and extruded hole.

(3) Place the 151701 Torsion Spring in the yoke of the bail in such a way that the spring is between the felt washer and that portion of the side of the bail that includes the spring anchor notch. The side of the spring with the "U" shaped end should be against the side of the bail. Position the "U" shaped end of the spring against the flat of the notch; install the remaining 156051 Eccentric Bushing through the hole in the bail, spring, felt washer and through the hole in the extruded arm side of the bail, respectively. Secure the bail assembly to the tapped hole in the magnet bracket using a 150089 Screw and 3640 Lockwasher.

\*NOTE

After assembly, the extension of the magnet armature must be below the eccentric bushing on the bail arm; the long, straight end of the torsion spring must be below the 156668 Spring Post on the center plate and against the 156599 Plate between the front and center plates, adjacent to the center plate.

e. Tape Guide Plate

Replace and position the tape guide plate in accordance with instructions in Teletype Bulletin 235B.

f. Magnet Cable

Route the 179660 Magnet Cable from the quick disconnect terminals of the coil to the terminals of the voltage source or control circuit used in the particular application.

NOTE

When remounting the LXD on its base, discard the existing front mounting screw and use the 173974 Screw furnished.

3. ADJUSTMENTS AND LUBRICATION

a. Make the following adjustments in the sequence given below (Bell System refer to standardized information):

(1) Replacing and Positioning Tape Guide Plate - See Teletype Bulletin 235B.

(2) Feed Wheel Detent - See Teletype Bulletin 235B.

\* (3) Feed Pawl - Make adjustment per Teletype Bulletin 235B except change clearance to read: Some to 0.003 inch.

(4) Make the new adjustments shown in Figures 1, 2, 3 and 4 of this specification.

(5) Replacing and Positioning Cover Plate - See Teletype Bulletin 235B.

b. Lubrication

For frequency of lubrication see Teletype Bulletin 235B.

(1) Saturate the following with KS7470 Oil:

(a) The 90361 Felt Washer on the blocking bail eccentric.

(b) The 131747 Felts at the armature pivot.

(2) Apply a light coat of KS7471 Grease at the following points:

(a) Armature extension at contact with blocking bail eccentric.

(b) Blocking bail extension at contact with feed pawl extension.

#### 4. PRINCIPLES OF OPERATION

a. Tape Withhold Mechanism

(1) When the magnet is energized it attracts the armature and the armature extension positions the blocking bail to block normal operation of the tape feed pawl.

(2) The transmitter sensing pins continue to sense and transmit the character being sensed at the time of blocking as long as the magnet is energized.

b. Operation with Horizontal Tabulation

(1) The tape withhold mechanism may be used to transmit the "LETTERS" character during horizontal tabulation of an associated Model 28 Page Printer.

(2) The associated page printer must be equipped with the 164476 Modification Kit: To provide horizontal tabulation transmitter distributor control mechanism to the Model 28 Printer. This set of parts is covered in Teletype Specification 5864S.

(3) To initiate tabulation, the code FIGS-G-LETTERS-LETTERS may be used in the transmitting tape.

(4) The tape withhold operating magnet must be wired through the normally open side of the 164476 Modification Kit transfer contacts.

\* (5) When the tabulation code FIGS-G is received by the printer, tabulation is initiated, causing the normally open contacts to close and thereby closing the tape withhold magnet circuit. The first LETTERS, or fill character, is read and transmitted before the feed pawl can be blocked by the bail; the second LETTERS character will be read and transmitted as long as tabulation occurs and the transfer contacts on the printer are closed.

(6) Termination of tabulation opens the transfer contacts and the operating magnet circuit permitting the blocking bail to return to the unblocked position under the influence of its spring and thereby permits normal operation of the transmitter feed pawl.

\* \* \*

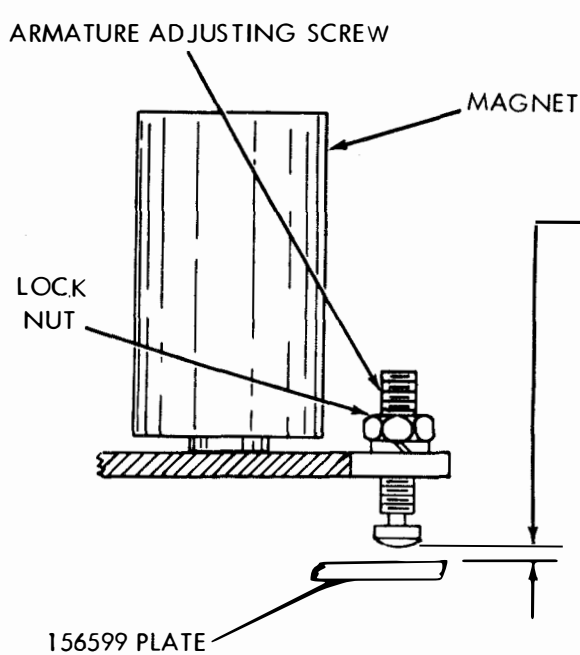

MAGNET ARMATURE GAP  
TO CHECK

WITH ARMATURE HELD AGAINST MAGNET CORE, ARMATURE ADJUSTING SCREW TURNED DOWN UNTIL IT JUST CONTACTS THE 156599 PLATE. BACK OFF THE SCREW 1-1/2 TURNS.

REQUIREMENT

CLEARANCE BETWEEN END OF ARMATURE ADJUSTING SCREW AND THE 156599 PLATE:  
MIN. 0.025 INCH---MAX. 0.035 INCH

TO ADJUST

WITH ARMATURE ADJUSTING SCREW LOCK NUT FRICTION TIGHT TURN ADJUSTING SCREW TO MEET REQUIREMENT. TIGHTEN THE LOCK NUT.

\*FIGURE 1

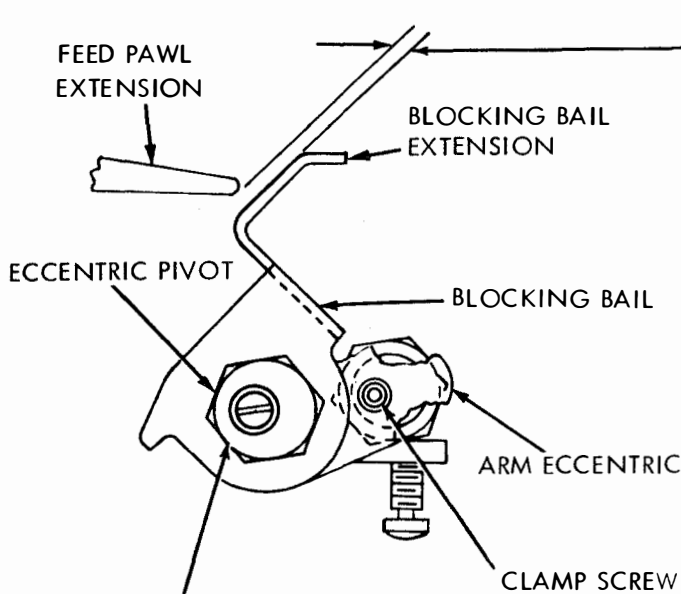

BLOCKING BAIL ARM ECCENTRIC  
REQUIREMENT

WITH SENSING FINGERS IN THEIR LOWERMOST POSITION, THE HIGH PART OF BLOCKING BAIL ARM ECCENTRIC TO THE RIGHT, AND THE HIGH PART OF BLOCKING BAIL PIVOT ECCENTRIC TO THE RIGHT, CLEARANCE BETWEEN THE EXTENSION ON THE BLOCKING BAIL AND THE FEED PAWL EXTENSION:

MIN. SOME

TO ADJUST

WITH BLOCKING BAIL ARM ECCENTRIC CLAMP SCREW FRICTION TIGHT ROTATE THE ECCENTRIC TO MEET REQUIREMENT. TIGHTEN CLAMP SCREW.

ECCENTRIC IN APPROXIMATELY THE SAME ANGULAR POSITION AS FEED PAWL ECCENTRIC.

\*FIGURE 2

BLOCKING BAIL ECCENTRIC PIVOT  
TO CHECK

WITH MAIN SHAFT LATCHED IN STOP POSITION, CLUTCH TRIPPED, AND TAPE WITHHOLD ARMATURE HELD AGAINST THE MAGNET POLE PIECE.

## REQUIREMENTS

- (1) CLEARANCE BETWEEN EXTENSION ON THE BLOCKING BAIL AND FEED PAWL EXTENSION AT CLOSEST POINT:

MIN. 0.002 INCH --- MAX. 0.035 INCH

## TO ADJUST

WITH BLOCKING BAIL ECCENTRIC PIVOT CLAMP SCREW FRICTION TIGHT ROTATE ECCENTRIC TO MEET THE REQUIREMENT. TIGHTEN CLAMP SCREW. CHECK THE BLOCKING BAIL ARM ECCENTRIC ADJUSTMENT IN FIGURE 2 AND REFINE IF NECESSARY.

- (2) CLEARANCE BETWEEN FEED PAWL AND FEED RATCHET AT CLOSEST POINT, AS FEED PAWL IS CAMMED OUT OF RATCHET DURING BLOCKING OPERATION

MIN. SOME --- MAX. 0.015 INCH

## TO ADJUST

REFINE BLOCKING BAIL ARM ECCENTRIC ADJUSTMENT AND REQUIREMENT (1) ABOVE.

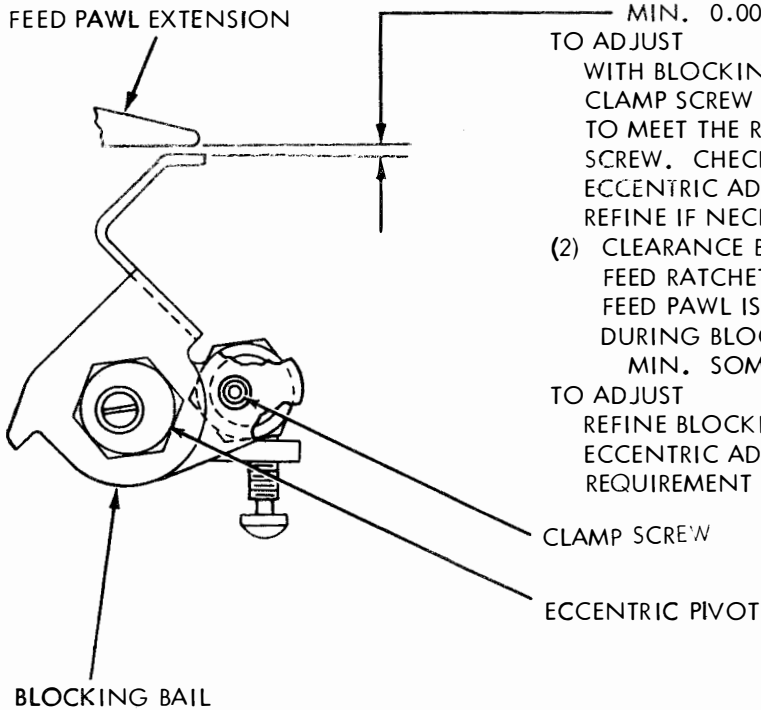

\*FIGURE 3

REPLACING AND POSITIONING TOP PLATE

## NOTE

LOOSEN NUTS (FRICTION TIGHT) THAT SECURE MOUNTING BRACKETS TO PLATE. PRESS TOP PLATE INTO POSITION WHILE GUIDING TOP PLATE MOUNTING SCREWS INTO NOTCH OF FRONT AND REAR PLATE. MAKE SURE THAT TOP PLATE SEATS FIRMLY AGAINST PROJECTIONS OF FRONT AND REAR PLATE (5 OF 6 PROJECTIONS SHOULD ENGAGE) AND TIGHT TAPE ARM EXTENSION IS UNDER TOP PLATE.

## REQUIREMENTS

- (1) MATING EDGE OF TOP PLATE SHOULD BE FLUSH TO 0.003 INCH UNDER FLUSH WITH EDGE OF TAPE GUIDE PLATE (WITHIN AREA OF TAPE LID) WHEN PLATE ENGAGES AT LEAST 5 PROJECTIONS.

## TO ADJUST

POSITION TOP PLATE, TIGHTEN MOUNTING SCREWS AND THEN TIGHTEN NUTS THAT SECURE TAPE GUIDE PLATE MOUNTING BRACKETS.

- (2) FEED WHEEL SLOT SHOULD ALIGN WITH SLOT IN TAPE GUIDE PLATE SO THAT FEED WHEEL ROTATES FREELY WITH START-STOP LEVER IN FREE-WHEELING POSITION.

## TO ADJUST

POSITION TOP PLATE TOWARD FRONT OR REAR TO ALIGN SLOT.

- (3) CLEARANCE BETWEEN PROJECTION OF TAPE LID AND TOP PLATE (TAPE LID LATCHED).

MIN. 0.010 INCH --- MAX. 0.020 INCH

## TO ADJUST

IF NECESSARY, LOOSEN TAPE LID BEARING BRACKET MOUNTING SCREWS AND POSITION TAPE LID. RETIGHTEN SCREWS AND RECHECK REQUIREMENTS.

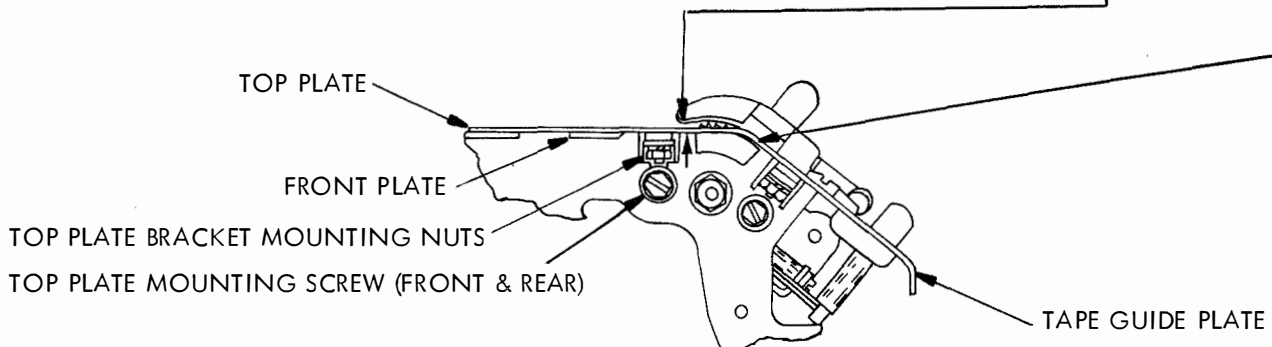

FIGURE 4