

NO **NOTES**

1. WIRING LEGEND:

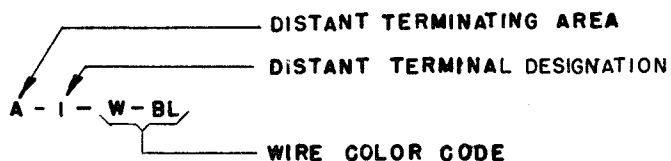

2. COLOR CODE

BK - BLACK	W-BK - WHITE- BLACK
BR - BROWN	W-BR - WHITE- BROWN
R - RED	W-R - WHITE- RED
O - ORANGE	W-O - WHITE- ORANGE
Y - YELLOW	W-Y - WHITE- YELLOW
G - GREEN	W-G - WHITE- GREEN
BL - BLUE	W-BL - WHITE- BLUE
P - PURPLE	W-P - WHITE- PURPLE
W - WHITE	W-S - WHITE- SLATE
S - SLATE	

3. UNIT WIRED FOR 115 VOLTS, 50 TO 60 CYCLE A.C. POWER INPUT ONLY.

4. PLUGS VIEWED FROM SOLDER TERMINAL ENDS

5. CIRCUITS SHOWN FOR .060 AMP. NEUTRAL SIGNAL LINE OPERATION. FOR .020 AMP. OPERATION REMOVE AND ADD CONNECTIONS AS TABULATED BELOW.

SIGNAL LINE CURRENT	CONNECTION REMOVED	CONNECTIONS ADDED
.020 AMP	K1-K2, J①1-J①2, D4-D5, D5-D7, D6-D8	J①3-J①4, D6-D7

11. WHEN LESU7/152 IS USED WITH LB5/229, THE TWO SPARE WIRES W-R&W-Y ARE USED FOR THE XD CONTROL SWITCH. CUSTOMER TO WIRE CABINET IN ACCORDANCE.

6. RECTIFIER SHOWN CONTROLLED BY POWER SWITCH. FOR CONTINUOUS OPERATION, REMOVE LEAD L-2-BK FROM TERMINAL E-2 AND CONNECT TO TERMINAL E-1. FOR OPERATION FROM MOTOR CONTROL, REMOVE LEAD L-2-BK FROM TERMINAL E-2 AND CONNECT TO TERMINAL E-3.

7. LINE SHUNT RELAY SHOWN CONTROLLED BY MOTOR CONTROL CONTACTS AND SHUNTING LINE RELAY COIL AND KEYBOARD SIGNAL GENERATOR CONTACTS.

a. IF KEYBOARD SHUNTING IS NOT DESIRED, REMOVE THE BLACK STRAP CONNECTED BETWEEN TERMINALS C-10 AND C-13 AND CONNECT TERMINALS C-9 AND C-13.

b. FOR DIRECT CONTROL OF THE LINE SHUNT RELAY FROM THE POWER SWITCH, REMOVE STRAP BETWEEN TERMINALS C-34 AND C-37 AND CONNECT TERMINALS C-34 AND C-35. TERMINAL C-13 MAY THEN BE CONNECTED TO EITHER TERMINALS C-9, C-10, C-11, OR C-15 TO OBTAIN THE DESIRED SHUNTING OF THE SIGNAL LINE CIRCUIT.

8. THE SPARE LEADS FROM THE KEYBOARD AND TYPING UNIT CONNECTOR PLUGS ARE TERMINATED IN THE RIGHT AND LEFT ENDS OF THE ELECTRICAL SERVICE UNIT RESPECTIVELY.

9. FOR ACCESSORY GROUP 152 SPLICE & TAPE SPARE WIRES AS FOLLOWS: F-9-W-Y TO R-6-W-T; F-10-W-R TO R-9-W-R; F-11-W-BK TO R-11-W-BK; F-15-W-O TO R-10-W-O.

10. REMOVE STRAP BETWEEN C-10 & C-11 IF SIGNAL LINE BREAK SWITCH IS USED.

A
SELECTOR MAGNET TERMINAL BLOCK

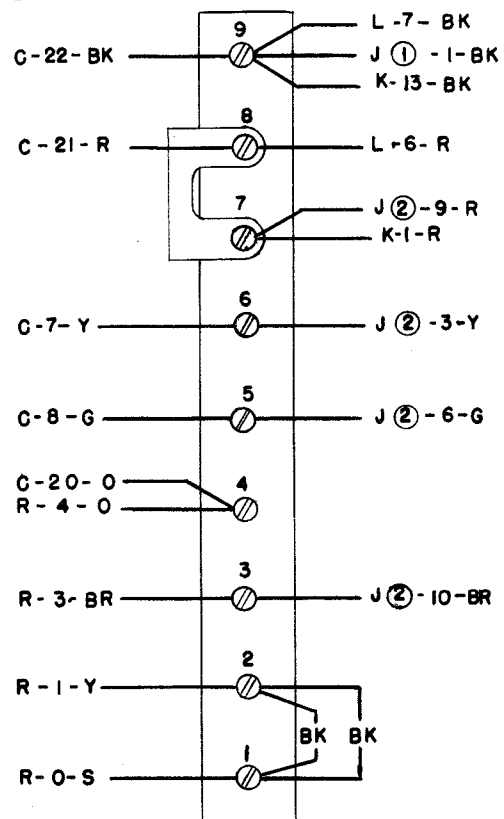

B
LINE TEST KEY TERMINAL BLOCK

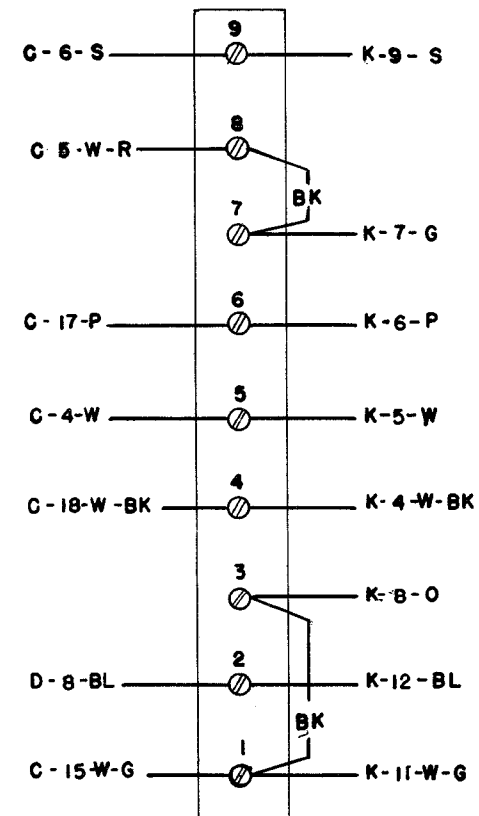

OR WHEN SIGNAL LINE BREAK SWITCH IS PRESENT,

F
KEYBOARD CONNECTOR PLUG

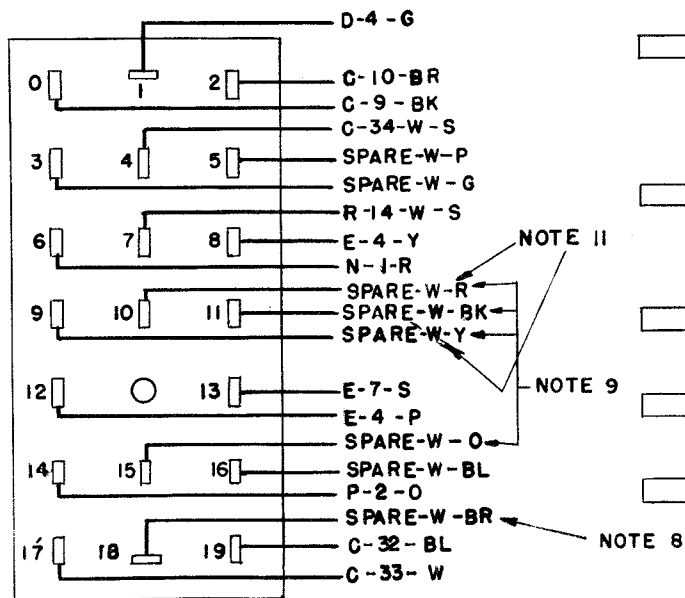

G
LINE PAD RESISTOR

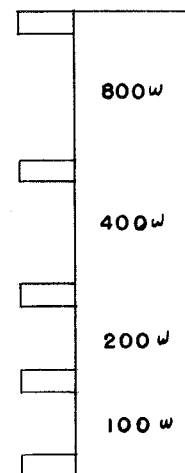

H
LINE SHUNT RELAY

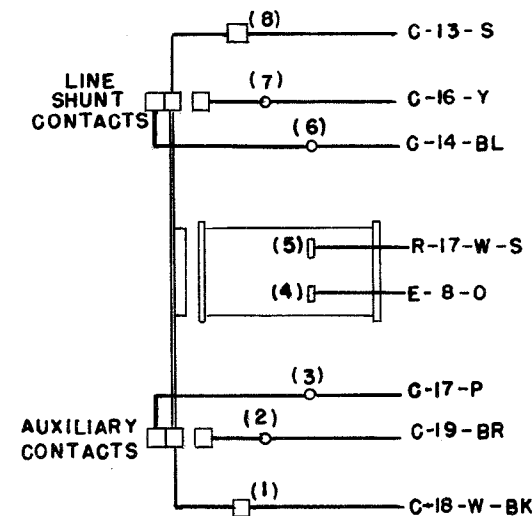

NOTE II
NOTE 9
NOTE 8

