

NOTES

COLOR CODE	
BK BLACK	G GREEN
BR BROWN	BL BLUE
R RED	P PURPLE
O ORANGE	S SLATE
Y YELLOW	W WHITE

1. WIRING LEGEND
 DISTANT TERMINAL AREA
 DISTANT TERMINAL DESIGNATION
 WIRE COLOR CODE
 D-4-BL

2. TERMINALS DESIGNATED IN PARENTHESES ARE NOT MARKED ON COMPONENTS

3. TERMINALS ON CONNECTOR SHOWN AS VIEWED FROM SOLDER END.

4. THE SPACING (S) SIDE ON THE CODE READING CONTACTS ARE NORMALLY CLOSED. THE MARKING (M) SIDE OF THE CODE READING CONTACTS ARE NORMALLY OPEN.

5. WHEN THE AUXILIARY CONTACTS ARE OPERATED FROM A SINGLE CYCLE FUNCTION CAM THE CONTACTS NEAREST THE MOUNTING BRACKET ARE NORMALLY CLOSED.

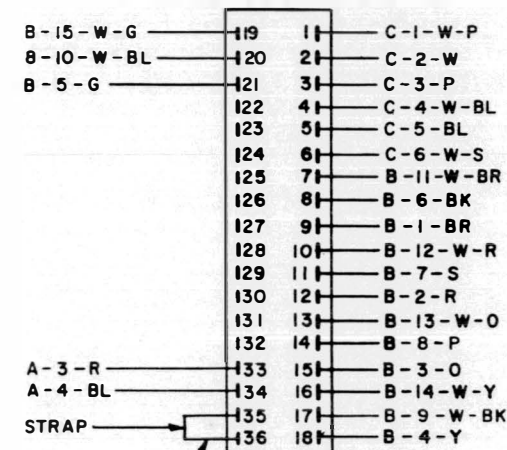
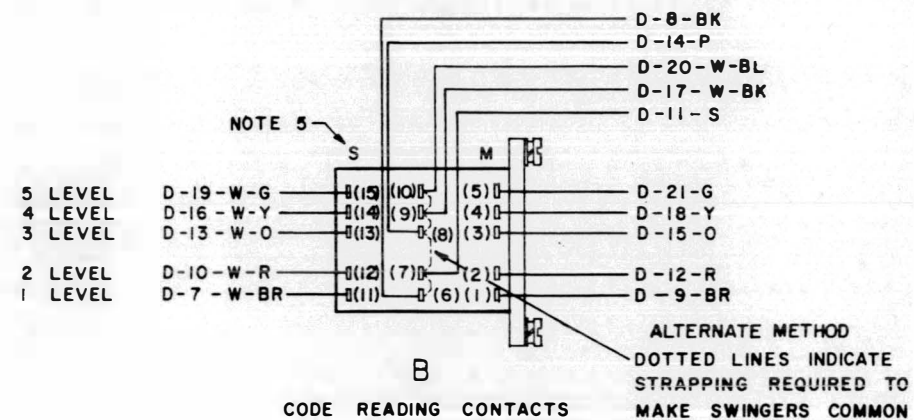
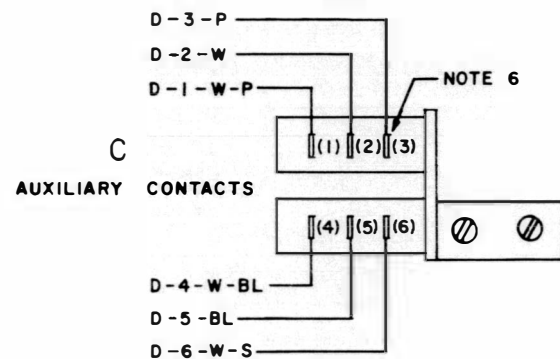
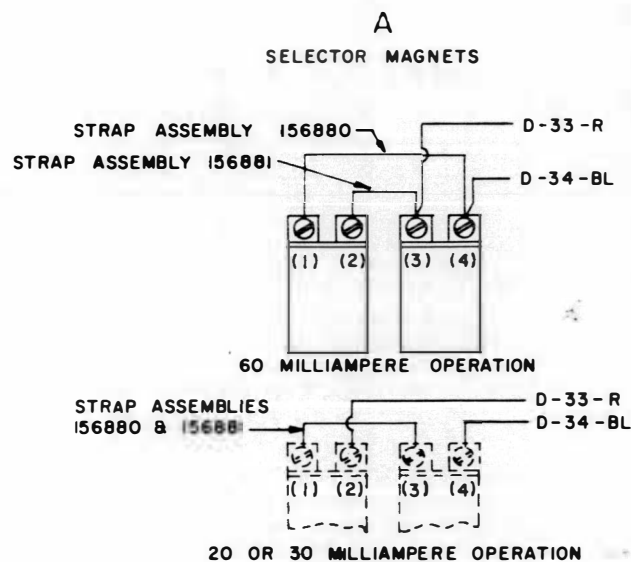

THESE TERMINALS ARE TO BE STRAPPED WITH NO. 20 GAGE WIRE ON ALL UNITS.

4706WD

REVISIONS		
ISS.	DATE	AUTH. NO.

APPROVALS

D AND R E OF M

E-NUMBER

PROD. NO. 4706 WD

ACTUAL WIRING DIAGRAM
 MODEL 28
 RECEIVING SELECTOR
 LRS2

DATE 5-11-61

P.D. FILE NO. 1-A65.192A

DRAWN R. R. W. CHKD

ENGD K. S. APPD

TELETYPE CORPORATION
 4706WD