

3742 WD

ISSUE	DATE	AUTH. NO.
A	4-5-60	28-13057
B	5-17-60	28-13280
C	9-27-61	69974-2
D	10-26-61	71421
E	11-24-61	71738
F	2-19-62	72507

- NO. NOTES
1. WIRING LEGEND
2. COLOR CODE
3. REFER TO WIRING DIAGRAM 2900WD FOR LMU20 MOTOR UNIT.
4. PART OF LMU20 MOTOR UNIT (162911 CABLE ASSEM.)
5. PART OF 162986 CORD ASSEM.
6. DOTTED LINES INDICATE AVAILABLE OPTIONAL ACCESSORIES.
7. A. SELECTOR MAGNET RESISTANCE: 2 X 170Ω PER CODE LEVEL.
B. CLUTCH TRIP MAGNET RESISTANCE: 200 Ω
8. EXTERNAL CIRCUIT FOR TAPE FEED OUT REQUIRED.
9. A. ON LARP 5, & 6 - CODE MAGNETS 0, 6, 7, & ASSOCIATED WIRING NOT PART OF THIS UNIT.
B. ON LARP 600 - CODE MAGNETS 5, 7, & ASSOCIATED WIRING NOT PART OF THIS UNIT.
C. ON LARP 700 - CODE MAGNETS 7, & ASSOCIATED WIRING NOT PART OF THIS UNIT.
10. A. NOT PART OF LARB 201.
B. CUSTOMER TO TERMINATE A.C. POWER CONNECTIONS TO THE 162911 CABLE ASSEM. (LMU20 MOTOR)
C. CUSTOMER TO FURNISH OWN A.C. GROUND TERMINATION TO BASE.
D. ON LARP 6 AND LARP 802 UNITS MOVE THE PURPLE LEAD TO TERMINAL #19 OF THE CONNECTOR.

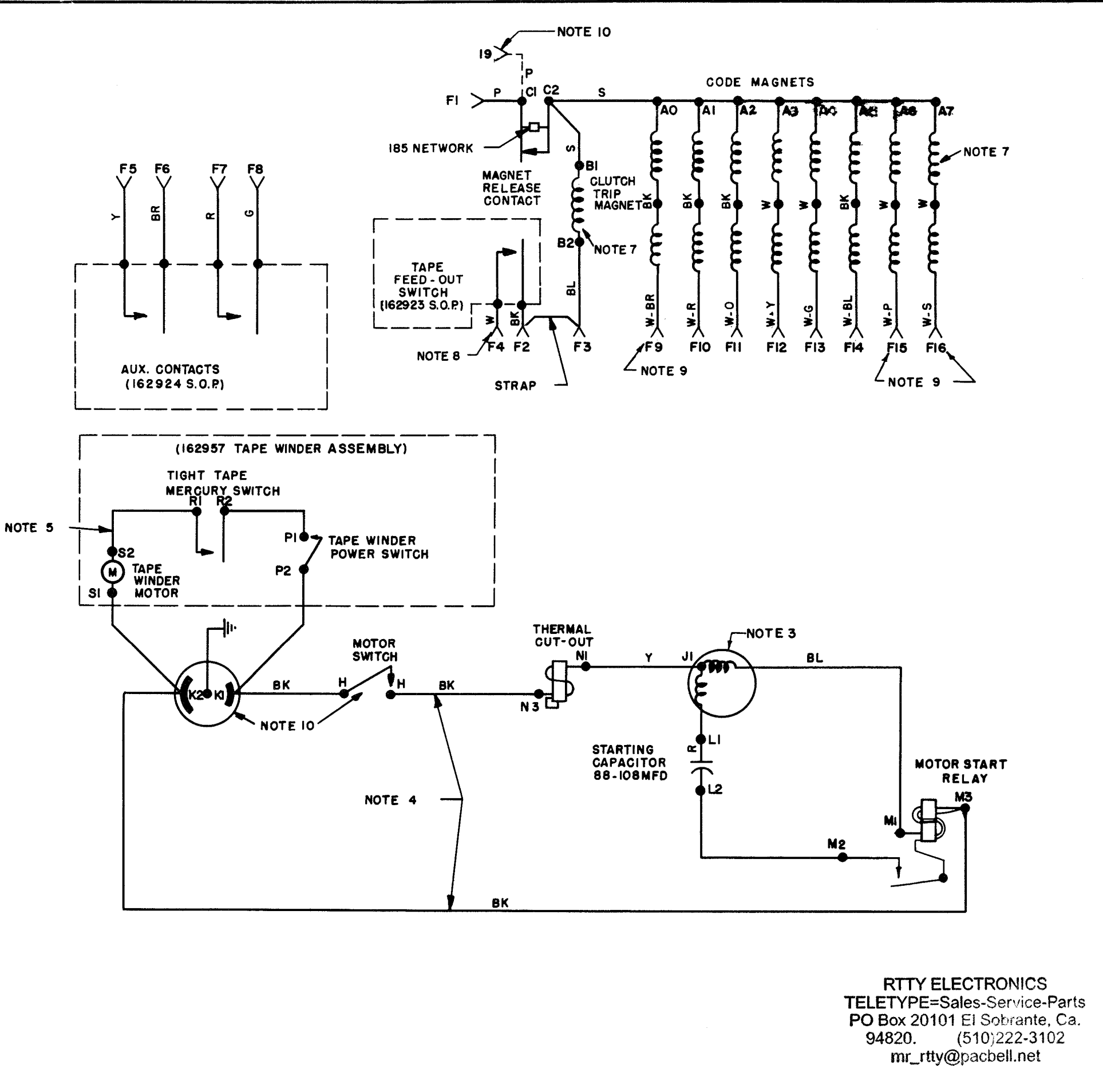

SCHEMATIC WIRING DIAGRAM
MULTI-MAGNET REPERFORATOR SET

LARP 5, 6
" 600
" 700
" 800, 802, 803
LARB 200, 201
LMU 20

APPROVALS

D AND R E OF M

E-NUMBER
PROD. NO. 3742 WD

DATE: 8-25-59
P.D. FILE NO. 14-35.65AA
DRAWN AB CHKD. *MB*
ENGD. T.J.T. APPD. *DALE*

TELETYPE

3742 WD

RTTY ELECTRONICS
TELETYPE=Sales-Service-Parts
PO Box 20101 El Sobrante, Ca.
94820. (510)222-3102
mr_rtty@pacbell.net