

R-391 500-1954-002
506 1934-002 R-391

NOTICE: When Government drawings, specifications, or other data are used for any purpose other than in connection with a definitely related Government procurement operation, the United States Government hereby incurs no responsibility or obligation whatsoever, and the fact that the Government may have furnished, or in any way supplied the said drawings, specifications, or other data is not to be regarded by implication or otherwise as in any manner recognizing the holder or any other person or corporation, or conveying any rights or permission to manufacture, use or sell any patented invention that may in any way be related thereto.

NEXT ASSEMBLY	USED ON	SWE. * APPROVAL
SM-D-178477	SC-DL-178467	
SM-D-178900		S/PR M/100423
SM-D-343600	SC-DL-248775	
SM-D-248975		

REVISIONS		DATE	APPROVAL
SYM	DESCRIPTION		
A ₂	A ₁ - ADDED FINISH NOTE. A ₂ - ADDED APPL. SM-D-343600, SM-D-248975, SC-DL-248775	6 OCT. 59	4242B-PC-59-A1-51 REV'D PME
B ₁	(1) FINISH WAS E 511.	17 JULY 1962	L.T. JM E.D.B.
C ₁	(1) FINISH WAS E 513	22 MAR 1965	21582 PC-61 REV'D PME
D	(1) MATL SPEC REF REV.	25 FEB 66	JLC JM RP E.D.B.
E	(1) ALLOY WAS 5454 PER SPEC QQ-A-200/6.	29 OCT 69	JLC EDB JMC RP

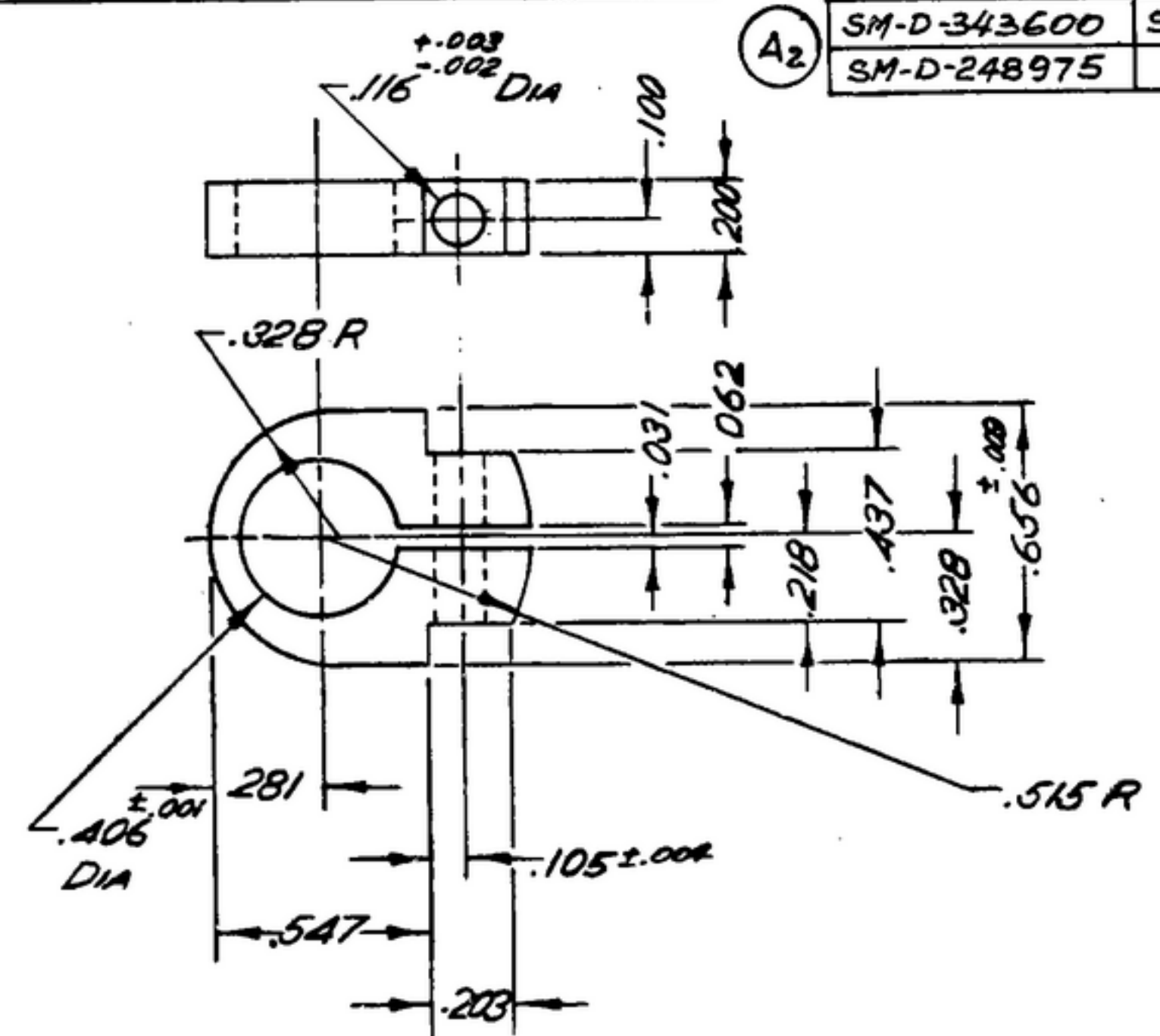

- (D) (E) ALUM. ALLOY EXTRUDED 7075, TEMPER 0, PER SPEC QQ-A-200/11.
- 1-.062 SLOT MAY VARY ±.02 FROM POSITION SHOWN.
- (A₁) 2.-FINISH :E511 PER MIL -F-14072.
- (B₁) (C₁)

NOTE:
*FOR INFORMATION ONLY,
CONTRACTOR MAY AT HIS
OPTION DEVIATE FROM
THESE PROCESS DETAILS

UNLESS OTHERWISE SPECIFIED	AUTHENTICATION	REVISIONS	DATE
DIMENSIONS ARE IN INCHES	DRAWN 2/852-PH-50-83		
TOLERANCES ON FRACTIONS ±	TRACED PHOTO		
DECIMALS ± .005	CHECKED <i>Ph</i>		
ANGLES ±	VERIFIED <i>PO BR</i>		
COMMERCIAL TOLERANCES APPLY TO STOCK SIZES	APPROVED <i>PO BR</i>		
ALL SURFACES ✓	REVIEWED <i>PME</i>		
	DATE 28 MAY 59	SCALE 2/1	FINISH 90-543

CLAMP

DEPARTMENT OF THE ARMY SIGNAL CORPS ENGINEERING LABORATORIES PORT MONMOUTH NEW JERSEY	SM-B-178486
---------------------------------------------------------------------------------------------	-------------

WHEN REFERRING TO THIS DRAWING STATE DRAWING NO., APPLICABLE ISSUE SYMBOL AND DATE