

REM 17

566-7330-002 E-3

NOTICE: WHEN GOVERNMENT DRAWINGS, SPECIFICATIONS, OR OTHER DATA ARE USED FOR ANY PURPOSE OTHER THAN IN CONNECTION WITH A DEFINITELY RELATED GOVERNMENT PROCUREMENT OPERATION, THE UNITED STATES GOVERNMENT THEREBY INCURS NO RESPONSIBILITY NOR ANY OBLIGATION WHATSOEVER; AND THE FACT THAT THE GOVERNMENT MAY HAVE FORMULATED, FURNISHED, OR IN ANY WAY SUPPLIED THE SAID DRAWINGS, SPECIFICATIONS, OR OTHER DATA IS NOT TO BE REGARDED BY IMPLICATION OR OTHERWISE AS IN ANY MANNER LICENSING THE HOLDER OR ANY OTHER PERSON OR CORPORATION, OR CONVEYING ANY RIGHTS OR PERMISSION TO MANUFACTURE, USE, OR SELL ANY PATENTED INVENTION THAT MAY IN ANY WAY BE RELATED THERETO.

NOTE:  
\*FOR INFORMATION ONLY, CONTRACTOR MAY AT HIS OPTION DEVIATE FROM THESE PROCESS DETAILS

*SWE APPROVAL		REVISIONS			
SYM	PRIOO42-5	SYM	DESCRIPTION	DATE	APPROV
		A <sub>2</sub>	A <sub>1</sub> - NOTE 1 WAS "CLASS 4 OR 5"; NOTE 2 WAS "MIL-P-12011" ADDED FLUX & SOLDER TO L/M. A <sub>2</sub> - ADDED APPL. SM-B-178977, SC-DL-248775.	9 OCT. 59	42428-59-A1 REV
B <sub>1</sub>	CA 847B1	B <sub>1</sub>	B <sub>1</sub> - 10S111330-6 WAS 10S130020	17 MAY 60	42428- REV PM

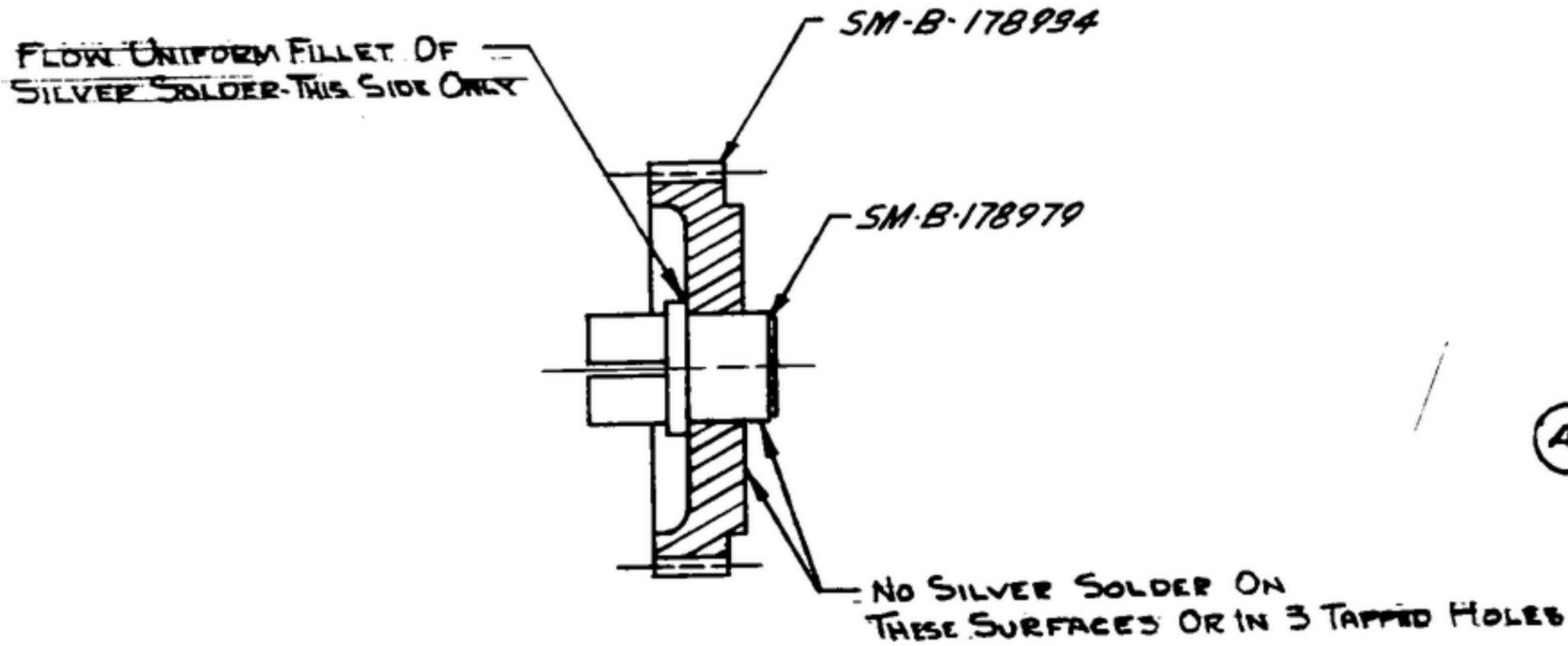

NOTES:

- (A<sub>1</sub>) 1 - SILVER SOLDER SHALL BE PER SPEC QQ-S-561 CLASS 4 USING FLUX PER US NAVY SPEC O-F-4
- 2 - PASSIVATE E-300 PER SPEC MIL-F-14072.

(A <sub>1</sub> )	10S130298	AS REQ'D	FLUX
(B <sub>1</sub> )	10S111330-6	AS REQ'D	SOLDER, SILVER
			1 SM-B-178979 HUB
			1 SM-C-178994 GEAR

REQD	PART NO.	DESCRIPTION	MATL	MATL SPEC

UNLESS OTHERWISE SPECIFIED		AUTHENTICATION		HUB ASSY	SIGNAL CORPS ENGINEERING LABORATORIES FORT MONMOUTH NEW JERSEY
DIMENSIONS ARE IN INCHES TOLERANCES ON FRACTIONS DECIMALS ANGLES		DRAWN	TRACED		
		21852-PH 50-93	PHOTO		
			CHECKED <i>h</i>		
			VERIFIED P.D.B.R.		
			APPROVED P.D.B.R.		
			REVIEWED P.M.E.		
		DATE 30 Oct 53	SCALE 2/1		
					SM-B-178978

(A <sub>2</sub> )	SM-B-178977	SC-DL-248775
	SM-B-178977	SC-DL-178467
	NEXT ASSY	USED ON
	APPLICATION	