

NOTICE: WHEN GOVERNMENT DRAWINGS, SPECIFICATIONS, OR OTHER DATA ARE USED FOR ANY PURPOSE OTHER THAN IN CONNECTION WITH A DEFINITELY RELATED GOVERNMENT PROCUREMENT OPERATION, THE UNITED STATES GOVERNMENT THEREBY ASSUMES NO RESPONSIBILITY FOR ANY ERRORS WHATSOEVER, AND THE FACT THAT THE GOVERNMENT MAY HAVE FORMULATED, FURNISHED, OR IN ANY WAY SUPPLIED THE SAID DRAWINGS, SPECIFICATIONS, OR OTHER DATA IS NOT TO BE REGARDED BY IMPLICATION OR OTHERWISE AS IN ANY MANNER LICENSES THE HOLDER OR ANY OTHER PERSON OR CORPORATION, OR CONFERS ANY RIGHTS OR PERMISSION TO MANUFACTURE, USE, OR SELL ANY PATENTED INVENTION THAT MAY IN ANY WAY BE RELATED THERETO.

THIS DOCUMENT HAS BEEN FURNISHED BY THE GOVERNMENT AND MAY BE REPRODUCED AND USED IN CONNECTION WITH ANY GOVERNMENT PROCUREMENT OR MANAGEMENT OPERATION.

\* FOR INFORMATION ONLY, CONTRACTOR MAY AT HIS OPTION DEVIATE FROM THESE PROCESS DETAILS.

ORIG. ISSUE A		REVISIONS	17 AUG 56	
SYM	DESCRIPTION	DATE	APPROVAL	

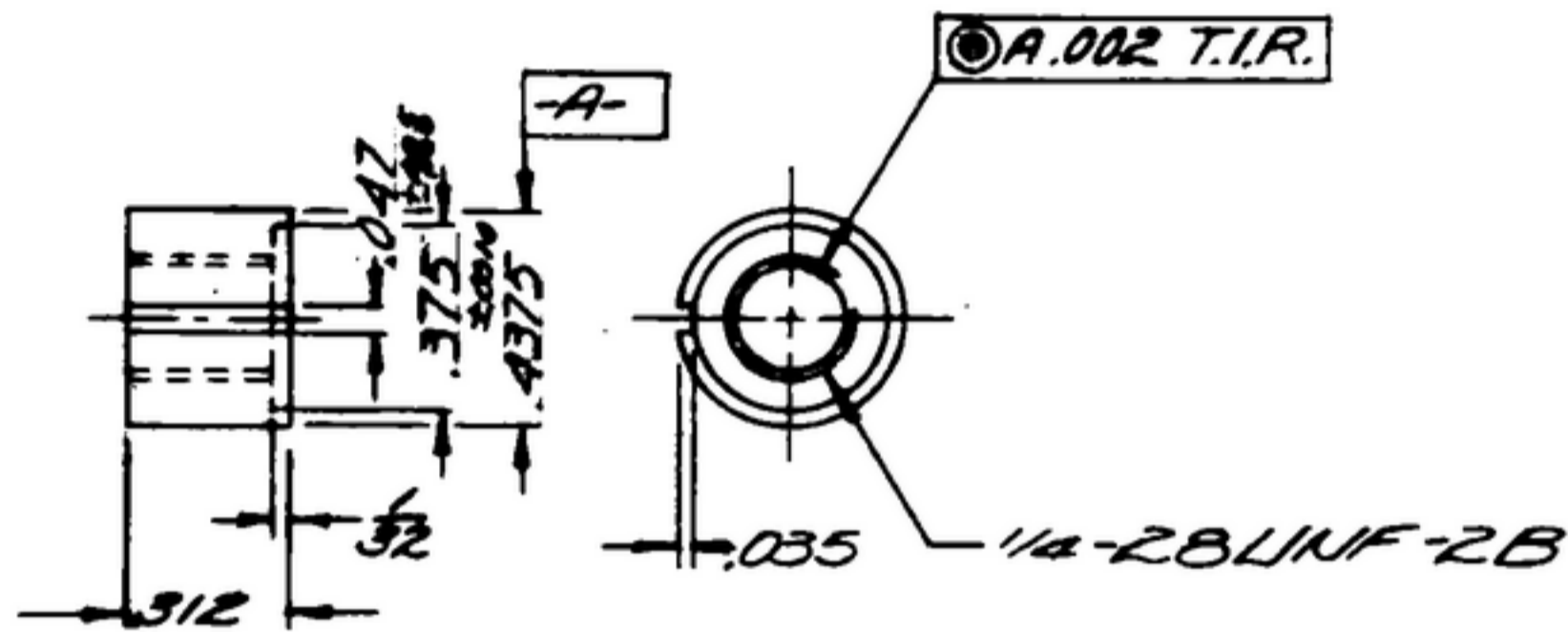

FREE CUTTING BRASS 1/2 H  
PER QQ-B-626, COND 2B

NOTES:

1. FINISH: BRIGHT ALLOY PLATE PER ALBALLOY PROCESS BY HANSON-VAN WINKLE-MUNNING CO. MATAWAN, N.J. OR EQUAL.
2. ALL THREADS PER H2B.

		UNLESS OTHERWISE SPECIFIED
		DIMENSIONS ARE IN INCHES
		TOLERANCES ON
		FRACTIONS DECIMALS ANGLES
		— 1.005 —
3663886	3661-57655	
NEXT ASSY	USED ON	
APPLICATION		

QTY	REQ	PART NO.	DESCRIPTION	UNIT	FINISHED SIZE	QTY	NOTE
LIST OF MATERIAL							
			HOLDER				
			COLLINS RADIO CO CEDAR RAPIDS IA 0819-PL-55-93 SIGNAL CORPS REVIEWED XXX APPROVED <i>R.J.</i> DATE 17 AUG 56			DEPARTMENT OF THE ARMY SIGNAL CORPS ENGINEERING LABORATORIES FORT MONMOUTH NEW JERSEY SM-B-34397	
			SCALE 2/1				