

INFO-TECH

M-6000

WARNING

HIGH VOLTAGE EXISTS INSIDE OF THE M-6000 CABINET.

ACCIDENTAL CONTACT WITH THIS VOLTAGE MAY CAUSE ELECTRICAL SHOCK WHICH MAY RESULT IN INJURY OR DEATH.

BEFORE OPENING THE CABINET BE SURE THAT POWER IS DISCONNECTED.

THE CIRCUITRY WITHIN THE CABINET IS CONSIDERED SERVICABLE BY ONLY EXPERT ELECTRONIC TECHNICIANS THOROUGHLY VERSED IN DIGITAL AND MICROPROCESSOR CIRCUITRY.

INEXPERT ATTEMPTS AT SERVICE MAY DAMAGE THE UNIT, PERMANENTLY, AND VOID THE WARRANTY.

INFO-TECH COMMUNICATIONS EQUIPMENT IS
MANUFACTURED BY

DIGITAL ELECTRONIC SYSTEMS, INC.
1633 WISTERIA COURT
ENGLEWOOD, FLORIDA 33533

INDEX

Introduction	1
General Description	1
Specifications	1
Operating Controls	5
Keypad Functions	5
Toggle Switch Functions	7
Status Line	8
Indicators	9
Installation	10
Line Voltage	10
Calibration	10
Receiver Connection	10
Video Monitor Connection	11
Video Display Selection	12
Printer Connections	12
Aux. Tuning Scope Output	12
Aux. Input/Output	13
Operating the M-6000	14
Morse (CW) Operation	14
RTTY Baudot Operation	15
ASCII Operation	19
TOR Operation	19
TDM Moore Operation	21
User Program Features	23
Alphabet Select	23
Initialization Mode	25
Sel-Cals	26
Diagnostics	28
Calibration	28
Remote Terminal Control	29
M-6000 Alignment	31
FCC Part 15 Statement	32
Warranty	33
Appendix I - Printer Control	35
Appendix II - J-6 Aux. Pinout	37
Appendix III - Semi-Conductors List	38
Appendix IV - Parts Location & Schematics	39

INTRODUCTION

You are now the owner of the most versatile demodulator available. This state-of-the-art device offers a host of features and capabilities never before offered. We recommend that you read this manual thoroughly in order to obtain the full performance capability engineered into this product. This manual provides users with information necessary for proper installation and operation of the Info-Tech M-6000 in normal operating situations. Additional information on specific operating and installation situations may be obtained by contacting your dealer.

GENERAL DESCRIPTION

The Info-Tech M-6000 provides video output of Morse, Baudot, ASCII, Time Division Multiplex (TDM Moore) and Telex Over Radio (TOR) codes when attached to a communications receiver and a video monitor. A variety of printers may also be added.

This converter includes capabilities and features usually not found on other units of its kind. Key advanced features include:

- * Bit inversion decoding of Baudot codes.
- * Decoding of the TOR codes (ARQ & FEC).
- * Decoding of the TDM (Moore) codes.
- * A unique "retro-print" feature allows the user to obtain hard copy of received data before it leaves the screen.
- * Crystal controlled tone filters with frequency and band width optimized, to the selected shift and speed, by the internal microprocessor.
- * Remote computer, or terminal, control of operation.
- * User programmable initialization and Sel-Cal codes.
- * Automatic filter tuning by microprocessor.

SPECIFICATIONS

Modes & Speeds:

ASCII - 75, 110, 150, 300, 600, 1050, 1200, & 1800 Baud
Plus variable non-standard rates from 37 to 251 Baud in
2 baud increments using the UP/DOWN toggle switch.

BAUDOT - 45, 50, 57, 75, & 100 Baud
Plus variable non-standard rates from 37 to 251 Baud in
2 baud increments using the UP/DOWN toggle switch.

TOR - ARQ & FEC Functions 100 Baud (receive only)

TDM MOORE - 2 channel 86, 96 & 100 Baud
4 channel 172, 192 & 200 Baud

MORSE - 5 to 120 wpm auto ranging (in 3 ranges)

BIT INVERSION - Baudot only - decodes any combination of
bit inverted security codes.

Filter Tone Sets

The M-6000 has two basic tone sets available in the digitally tunable channel filters: the high tone set and low tone set. In the Baudot, ASCII (thru 300 baud), TOR and TDM Moore modes; the high tone set Mark will be fixed at 2125 Hz. and the low tone set Mark will be fixed at 1275 Hz.

The Space frequencies have several pre-programmed positions that will provide fixed shifts of 85 Hz., 170 Hz., 425 Hz., 850 Hz. and 1200 Hz.

At 300 baud and above the additional fixed tone sets are provided:

Screen Indication	Space Freq (Hz.)	Mark Freq (Hz.)
1030	1070	1270
103A	2025	2225
C210	1180	980
C21A	1850	1650
C231	1700	1300
C232	2100	1300
B202	2200	1200

For variable non-standard shifts, you may vary the space frequency from the last selected space frequency, in 5 Hz. increments, from 85 Hz. thru 1540 Hz. shift, by using the LP/DOWN toggle switch.

Inputs

Audio - 4 to 600 ohms .25V p-p.

Aux. - TTL Levels (mark = +5V). May be used as an output from the demodulator or as an input to the microprocessor system.

Outputs

Video - Composite video, 75 ohm, 1.5v p-p, negative sync, 5x7 dot matrix, upper case ASCII character set, 16 or 24 lines of video, 36 or 72 characters per line. Scrolling, no breakup of words of less than 5 characters at end of line (Morse or RTTY 36 character line only). 50 or 60 Hz. vertical refresh. (50 Hz. optionally selected by dipswitch).

Printer Drives - Loop (20 or 60 ma.), MIL188, RS232 levels and parallel ASCII, all with handshaking.

Printer Modes & Speeds

Serial: Baudot 45, 50, 57, 75 Baud
ASCII 110, 150, 300, 600 Baud

Parallel: (ASCII 7 bit Centronics™ standard)

Demodulators

RTTY - Microprocessor controlled, switched capacitor filters comprise the pre-filters, channel filters, and post detector low pass filter for exceptional control and flexibility.

Both high tone and low tone sets are available with shifts from 85 Hz. thru 1200 Hz.. A variable control allows for shifts to be selected between standard shifts.

Switched capacitor filter frequencies are accurate to 1.5% or better.

Morse - A PLL, superhetrodyne demodulator centered on 750 Hz. or 1000 Hz. exhibits excellent dynamic range and tracking ability.

Rear Panel Jacks

Accessory Jack
Aux. Tuning Scope
Parallel Printer
Audio Input
Video Output

Power Requirements

115/230 VAC 50/60 Hz. 25 watts max. The unit is set for 115 VAC 60 Hz. when shipped. See INSTALLATION section to change power.

Size

16-3/8" wide x 3-1/2" high x 10-3/4" deep exclusive of rubber feet and rack handles.

Weight

9 lbs.

Physical Description

The M-6000 consists of a main board which contains all of the microprocessor, digital, analog, and power supply circuitry, and a front panel board which supports the indicators and toggle switches.

The main operation of the unit is controlled by a 4x4 keypad on the front panel with additional control provided by 10 toggle switches all located on the front panel.

All input and output connectors are on the rear panel. Printer mode and speed, and video format, are controlled by 7 dip switches accessed through a cut-out in the bottom of the cabinet.

Other Features

Computer (terminal) Control - Serial ASCII, 4800 baud, 8 data bits, no parity, 2 stop bits, no protocol, 3 wire control at RS232 levels (data-in from computer, data-out to computer, handshake from computer).

Status Line - Bottom line on video screen displays (in reverse video) the status of functions controlled by the key pad.

Printer Buffer - A 1800 character printer buffer is used for reasonable down conversion of speed and storage for handshaking.

OPERATING CONTROLS

KEYPAD FUNCTIONS

The operation of the keypad involves stepping thru a sequence of functions. For instance; each press of the <A> keypad will step through the various ASCII speeds available thus one keypad can be used to select several operations.

The following functions are controlled by the 4x4 keypad located on the front panel.

Keypad Function

- <A> Selects ASCII code operation at the fixed speeds of:
75, 110, 150, 300, 600, 1050, 1200, 1800 Baud.
- Selects the Baudot (Murray) code at the fixed speeds of:
45, 50, 57, 75, 100 Baud.
- <C> Selects the CW (Morse) mode of operation at three speed
ranges (slow, medium, & fast).
- <D> Selects the TOR and TDM (Moore) Codes.
In TOR you may select the ARQ or the FEC modes
(speed and shift are automatically selected at 100
baud and 170 Hz. when in the TOR modes).
In the TDM (Moore) the <D> key will select between:
 TDM2 (2 channel) at 96 Baud and
 TDM4 (4 channel) at 192 Baud.
To select 86 or 100 baud in TDM2, or 172 or 200 baud in
TDM4 use the UP/DOWN switch.
- <1> Speed Read Out - The Speed Read Out feature is active only
in the RTTY modes through 300 baud. Speed read out is
accomplished by pressing the <1> keypad.

The word BAUD will appear at the right side of the status line and in a short time the speed in baud will be indicated by B=nnn. Then, in approximately 10 to 12 seconds this portion of the status line will go blank.

Speed read out time is dependent on the received baud rate. ie, slower speeds take more time to read out.

The read out in baud will be to the nearest standard baud rate. (ie: 96 Baud TDM would be displayed as 100 Baud)

- <2> Multiple Scroll Inhibit (MSI) - Eliminates multiple scrolls
(line feeds) on the screen and printer. A paper and screen,
space saving device when the sending station sends more than
one line feed between lines of text. When this function is
on, an indication of MSI will appear on the status line.
MSI will not function on the remote computer terminal.

<3> AGC Control - Selects between a fixed gain or Automatic Gain Control of the input audio signal. The fixed gain position should produce a limiting signal at the filters. When this function is on an indication of AGC will appear on the status line. Under normal conditions you should leave the AGC on to prevent "flat topping". On a very weak signal you may turn off the AGC to obtain additional gain.

<4> (Dual Function)

Baudot Mode - Start Bit Inversion Scan

Baudot Mode: Turns on the automatic mode of BIT INVERSION SCAN. A second press of this key turns off the BIT INVERSION MODE.

TDM Moore Mode - Sync. Auto

TDM Moore Mode: provides for automatic synchronization with the signal while signal is idling.

<5> (Dual Function)

Baudot Mode - Manual Step-thru Bit Inversion

Baudot Mode: Manual step-thru of the various bit inversion combinations, one step for each keypress. Pressing <4> after pressing <5> will place the M-6000 into automatic "BI" mode.

TDM Moore Mode - Sync. Manual

TDM Moore Mode: Provides for manual synchronization with the incoming TDM Moore signal.

<6> Moore Channel Select - Steps thru the various available Moore code channels on a particular signal. On TDM2 channel it will select between channel A & B. On TDM4 channel it will select between channels A, B, C & D.

<7> Case Change - Each press of this button changes from one case to the other (ie: Figures to Letters).

<8> (Dual Function)

Baudot, TOR or TDM (Moore) Modes - Unshift on Space

Baudot, TOR, TDM (Moore) - When "on" it causes the data output to automatically shift to "Letters" case upon receipt of a "space" character in Baudot mode. When this function is on, an indication of LOS will appear on the status line.

ASCII Mode - Parity selection

ASCII: Odd, even, or none. When this function is on an indication of ODD, EVN or (blank) for "none", will appear on the status line.

- <9> Demodulator Shift Selection - Pressing this button steps between the various fixed tone shifts offered on ASCII, Baudot and TDM Moore Codes.
- <0> Clears the Video Screen
- <#> Retro-Print - Causes data in the (1800 character) buffer to be sent to the printer.
- <*> Automatic Filter Tuning Feature - Allows the microprocessor to retune the filters to the tone pair coming from the receiver if the tone pairs being received are between 1200 and 3000 Hz.
The Automatic Filter feature will not function properly unless the unit has been calibrated. To calibrate the M-6000 see the "Calibrate" section of the Diagnostic Operation on page 28. The shift, to which the M-6000 has tuned itself, will then be displayed on the status line and will generally be within 15% of the actual shift. To restore operation to standard tone pairs turn HI TONE/LOW TONE switch on and off once.

TOGGLE SWITCH FUNCTIONS

UP/DOWN TOGGLE SWITCH

Shifts either the speed (Baud rate) or shift up or down from its last fixed position as determined by the last keypad pressed. Holding this switch in either position will cause continuous stepping until the switch is released.

WIDE/NORMAL/NARROW TOGGLE SWITCH

Increases or decreases the bandwidth of the main filters by one step from a pre-determined normal point.

SEL-CAL "ON" TOGGLE SWITCH

Places the system in the Sel-Cal mode so that only data, received after one of the selected Sel-Cal, will be sent to the printer, when the printer switch is in the "Auto" position.

HIGH TONE/LOW TONE TOGGLE SWITCH

Changes the tone set on the Mark and Space filters from high tone to low tone set. For actual frequencies, refer to later paragraphs.

POWER TOGGLE

Switches power to the M-6000.

MO/BOTH/SO TOGGLE SWITCH

Selects the Mark filter only, Space filter only, or both filters for possible relief from adjacent channel interference.

NOR/REV TOGGLE SWITCH

Switches the sense of the digital signal to the microprocessor.
(RTTY only).

ATC "ON" TOGGLE SWITCH

Selects the Automatic Threshold Circuit for better operation during fading conditions where one signal, Mark or Space might fade out.

PROGRAM TOGGLE SWITCH

Places the system in the "program" mode so that certain user definable data (sel-cals, default mode, etc.) may be programmed in the safe RAM by use of the keypad.

PRINTER (ON/OFF/AUTO) TOGGLE SWITCH

This switch determines when data will be sent to the printer ports (both parallel & serial).

When the switch is "on" all data received will be sent to the printer.

When the switch is "off" no data will be sent to the printer, except when the retro-print key (<#>) is pressed.

When the switch is in "auto" position, data will be sent to the printer if a proper Sel-Cal is received or the digital auto-start is activated.

The digital auto-start activates when a space is received and is turned off when 16 characters are received without a space.

THE STATUS LINE

The bottom line of the video display is used as a status line. The status line is a visible indicator of operations selected by the keypad.

The status line will indicate the following:

- A. Mode of operation.
- B. Operating speed in bauds or W.P.M. range.
- C. Shift in Hertz.
- D. U.O.S. enabled.
- E. M.S.I. enabled.
- F. A.G.C. enabled.
- G. Bit inversion pattern or Speed Readout

A typical status line is shown below:

```
BAUDOT 100 850 UOS MSI AGC 00111
```

This indicates that the M-6000 is set in the Baudot mode, 100 Baud, 850 Hz. shift, UOS is enabled, MSI is enabled, AGC is enabled and it is set for a Bit Inversion pattern of 00111.

INDICATORS

LED FUNCTIONS

- POWER - Indicates power to set.
- LEVEL - Indicates adequate audio level to set.
- MK - Indicates reception of a MARK tone.
- CW - Indicates when a "key down" signal is received.
- SP - Indicates reception of a SPACE Tone.
- AS - Indicates operation of the Auto-Start System.
- DATA - Indicates that data is being received by the microprocessor and, when in the TOR or Moore modes, indicates proper synchronization with the signal.
- BUFFER - Indicates a buffer overflow.
- SEL-CAL - Indicates reception of a user-programmed Sel-Cal.
- TUNE ERROR - Indicates improper tuning, multi-path distortion, and/or selective fading. This indicator is useful through 300 baud for precise tuning of a RTTY signals. Proper tuning, without fading, or multi-path distortion, will be indicated by the LED being off, however in normal operation some flicker of the LED will be experienced.
- DATA ERROR - Data being received by microprocessor does not meet specification selected by mode and speed controls. This indicator when "off" generally indicates proper mode, speed, and phase selection.
- BAR-GRAPH "METER" - A solid state LED tuning meter. Tune signal for maximum rightward deflection.
- ON SCREEN BAR-GRAPH - Functions the same as the LED bar-graph meter.

INSTALLATION

The basic installation of the M-6000 is very simple. For normal operation the user simply must plug in the AC cord, calibrate the M-6000, provide audio from the receiver and connect the video monitor.

LINE VOLTAGE SELECTION

If your power mains are 115VAC you may immediately connect your M-6000 to the mains. To convert the M-6000 to 230V locate the recessed switch on the rear panel and change it to indicate "230 V".

M-6000 CALIBRATION

Please refer to page 28 of this manual for calibration instructions.

RECEIVER CONNECTION

Any good quality communications receiver will suffice for use with the M-6000. However stability, sensitivity, and selectivity are the most important attributes of a good RTTY communications receiver. Examples of suitable receivers would include: Japan Radio NRD-515, Japan Radio NRD-525, Kenwood R-1000, Kenwood R-2000, Icom R-70, Icom R-71A, Yaesu FRG-7000, Yaesu FRG-7700, and Yaesu FRG-8800.

The best point of connection to your receiver would be the "Record", or "Line Output". If your receiver does not provide such outputs, then you may connect the M-6000 "INPUT" to the earphone or speaker outputs using the 2 conductor phone plug (supplied) and an appropriate length of two conductor wire. Shielded wire may be used for this cable.

RECEIVER INPUT LEVEL ADJUSTMENT:

The M-6000 provides for a wide range of audio input levels from receivers.

Two adjustments are available to insure that your M-6000 is receiving the proper level of audio from your receiver. The M-6000 is shipped with the controls set for use with a high level output receiver such as the Japan Radio NRD-515. If you are using such a receiver no adjustment will be necessary. However, if your receiver has a lower level output (Kenwood R-2000, Icom R-70 or R-71A etc.) the level will have to be adjusted if you wish to use the "Record Output" jack on your receiver.

The following adjustment should be made only by QUALIFIED persons:

1. Tune in a medium strength RTTY station and observe the "LEVEL" LED on the front panel. If this LED is "on", it is an indication that there is adequate audio input from your receiver. No adjustment is required.

2. If the "LEVEL" LED is not on you will need to increase the gain of the input amplifier in the following manner:
 1. Remove the AC power cord from the rear panel socket.
 2. Remove the top cover of the M-6000.
 3. Locate input level control no. "1" (located on the main PC board, adjacent to the parallel printer output jack). Re-install the power connector, being careful to avoid the rear section of the M-6000 near the power connector.
 4. Adjust control no. "1" until the "LEVEL" LED just illuminates, with a medium strength RTTY station tuned in properly.
 5. If the adjustment of control no."1" does not cause the "LEVEL" LED to illuminate then locate fixed resistor "2" (located 1-1/2" toward the accessory jack from control no."1"). Cut one lead of this resistor and re-adjust control "1" so that the "LEVEL" LED just illuminates.
 6. The M-6000 is shipped with the controls set for use with a high level output receiver (NRD-515). If your receiver has a lower level output (ICOM R-70 or R-71A record jack) you will have to clip resistor "2" to obtain proper operation.
 7. Replace the top cover of the M-6000.

VIDEO MONITOR CONNECTION

The M-6000 puts out composite video designed to work with nearly all monochromatic (ie. "black & white") monitors. As the video display output is a fairly wide band signal, it is recommended that a 12" high quality video monitor be used with the M-6000.

A monitor, whose specifications indicate that it will display a 24 line x 80 character display, with RS-170 or equivalent input, will perform properly.

Video monitors that are known to work well with the M-6000 are the Heath/Zenith ZVM-121, ZVM-122, ZVM-123, and the Sanyo VM-4509, VM-4512.

The use of a "converted TV set" is not recommended because of the inherently poor bandwidth of the TV and the potential for shock hazards with a non-transformer isolated TV. The use of an RF modulator will also give poor results.

The video monitor is connected to the "VIDEO" jack on the rear panel using the RCA type pin plug supplied. Be sure that your cable to the video monitor is a good, quality, shielded coax. The use of double shielded coax (RG-232/U, RG71B/U, RG62B/U, RG55/U) will effectively eliminate any video hash radiation.

VIDEO DISPLAY SELECTION

The user has his choice of 4 different video display formats (16 or 24 lines) and (36 or 72 characters per line). The selection of this display is determined by the settings of dip switches located on the bottom of the main PC board.

To locate these switches you must look on the bottom of the M-6000.

Note: Power should be off when setting any dipswitch!

Character x Line	Switch 1	Switch 3
36 x 16	off	on
72 x 16	on	on
36 x 24	off	off
72 x 24	on	off

Switch 2 controls the vertical refresh rate of the video display.

For 60 Hz. power systems this switch should be OFF.

This would be the correct setting for USA, Canada and Japan.

For 50 Hz. power systems this switch should be ON.

PRINTER CONNECTION

The standard M-6000 will drive any ASCII or Baudot printer that will interface to a 20 or 60 ma. current loop, RS232C level, or MIL188A level and operate at speeds of 60, 66, 75, or 100 wpm in Baudot or 110, 150, 300, or 600 Baud in ASCII. For instructions on printer connections please refer to APPENDIX I.

AUXILIARY TUNING SCOPE OUTPUT

A jack labeled SCOPE is provided on the rear panel for attachment of an external oscilloscope for RTTY tuning.

For proper hook-up the Mark signal is on the ring, the Space signal is on the tip and the sleeve is ground.

The mark should be connected to the horizontal input of the scope and the space should be connected to the vertical input.

The Info-Tech M-610 RTTY tuning scope will easily interface with the M-6000.

AUXILIARY INPUT/OUTPUT

J6- 8 is the Aux. I/O. This connection provides a TTL level output from the demodulator or a TTL level input to the microprocessor. This I/O enables the M-6000 to be used with a keyboard or external demodulator.

No level greater than +5.0 volts may be connected to this point without possible damage to the M-6000, or the connected equipment.

Note: The M-6000 Normal/Reverse switch will not invert data on the Auxiliary input.

OPERATING THE M-6000

Before operating the M-6000 review the description of the 4x4 keypad, and toggle switches found earlier in this manual.

After you have connected the the receiver, and the video monitor, locate the M-6000 power switch located in the upper right hand corner of the toggle switch bank, place this switch in the "up" position. This applies power to the M-6000. The screen will appear "scrambled" for about 2 seconds. This is normal.

The words INFO-TECH M-6000 will appear (in reverse video) in the center of the screen. Below this appears the M-6000 version number. Please indicate this number when corresponding with the factory or your dealer regarding your M-6000. The status line will appear at the bottom. You will probably have to adjust your monitor (vertical and horizontal) to center the screen and insure the total visibility of the status line.

MORSE (CW) OPERATION

To copy Morse Code (CW) press the <C> keypad. Your M-6000 is now in the Morse (CW) mode at medium speed (10-40 words per minute).

If your High Tone/Low Tone switch is set for High Tone then the M-6000 wants to "hear" a 1000 Hz. beat note from your receiver. If this switch is set for Low Tone then the M-6000 will want to hear a 750 Hz. beat note from your receiver.

Set your receiver for C.W. operation, tune in a C.W. signal and adjust your BFO or fine tune your receiver until the "CW" Lock LED is flashing in time with the incoming code and the bargraph LED is indicating maximum movement to the right.

Care should be taken that you do not over-drive the M-6000 with too much signal. Best reception is often obtained by reducing the RF gain control on the receiver to the point where there is no flicker on the CW lock light, during key-up times, and the "LEVEL" LED does not turn on.

The M-6000 will take a short time (3-8 characters) to "Lock-on" to the code being sent and after it is locked you should see printing on your screen.

A good frequency to practice reception of Morse Code is 13033.5 KHz. This is the Marine Coast Station, WCC, which operates around the clock and normally sends "good" code.

The MORSE MED (Morse medium speed) position will copy 95% of the CW sent on shortwave. For reception of code slower than 10 w.p.m. you can press the <C> key until SLOW appears on the status line. For reception of code faster than 40 w.p.m. you should press the <C> key until FAST appears on the status line.

The M-6000 Morse section will decode CW only when it is properly sent, with reasonably constant speed and character spacing.

RTTY BAUDOT OPERATION

RTTY RECEPTION PROBLEMS

Perfect copy of shortwave (HF) RTTY transmissions is not guaranteed just because it is a code not subject to interpretation. There are several "natural" obstructions to perfect copy. Basically these obstructions fall into the three following categories:

- 1) **Multipath Distortion** - Caused by the signal from the transmitter arriving at the receiving antenna via two different paths, at slightly different times, which causes the mark and space pulses to be smeared, stretched, or over-lapped to the extent that they are decoded improperly.
- 2) **Fading and Selective Fading** - Caused by the ionospheric propagation of H.F. signals.

Naturally if the signal fades out completely the information not received during the fade will not be printed.

Selective fading, wherein only the mark or space appear to fade out will also cause loss of intelligence in the receiving installation.

- 3) **Noise** - Large scale static crashes and impulse noise may both interfere with RTTY reception.

The large static crash can obliterate the signal and impulse noise, whose pulse width closely approximates the bit-width of the marks and spaces of the RTTY signal, can fool the demodulator system into printing errors.

Note, that in all cases of the aforementioned disturbances, greater errors can occur when the transmission rate is faster. Thus, most H.F. RTTY occurs at 60 or 66 W.P.M. rather than 100 or 132 W.P.M.

Experimentation with the demodulator controls will enable the user to partially overcome these propagation abnormalities.

Once the signal is properly tuned, there are three variables in the reception of RTTY that must be determined and their determination is simply a matter of quick trial and error.

RTTY (BAUDOT) TUNING

The Baudot or Murray code is the most common type of RTTY code in use today, comprising about 80% of the RTTY signals you will hear. Not all of these signals are decodable by the M-6000 because of the use of special encryption of the Baudot mode by the sender.

Keep in mind that there are three variables when tuning an unencoded Baudot RTTY signal:

Speed - (Baud rate)

Shift - (difference between the Mark and Space tones sent)

Sense - (whether the signal is "Normal" or "Reversed")

As a general rule:

- (1) 95% of Amateur RTTY is sent at 45 Baud (60 wpm) and 170 Hz. shift.
- (2) Commercial press is sent at 50 Baud and 425 Hz. shift.
- (3) Weather is sent at 75 Baud and 850 Hz. shift.
- (4) USIA sends at 75 Baud and 425 Hz. shift at 14638.4 Khz.

You might want to practice using your M-6000 by tuning some Amateur (HAM) RTTY stations. Set your receiver on either the RTTY, LSB, or CW mode and tune it to 14090 KHz. plus or minus 10 KHz. This is the 20 meter amateur RTTY band and most signals here are 45 Baud and 170 Hz. shift. Set your M-6000 for this mode, speed, and shift (use the key for the mode and speed and the <9> key for the shift). The status line will now begin with BAUDOT 45 170 . Set the "Wide/Narrow" switch for NORMAL, the SO/MO switch in the center at MS and the ATC switch to the ON position. Tune your receiver for maximum "S" meter reading on a RTTY signal then adjust the receiver BFO or fine tune so that the M-6000 Bar Graph deflects to the right, and both "MARK" and "SPACE" LEDs are flashing. This indicates proper tuning.

If you are not getting good print on the screen, throw the "NORM/REV" switch to its alternate position. You must try the "NORM/REV" on every Baudot RTTY signal that you encounter. Good print should follow.

Tuning commercial RTTY is very similar. As a beginner you should start with known stations with known speeds and shifts. Good reference books on RTTY frequencies are a must! Some useful RTTY publications include:

GUIDE TO UTILITY STATIONS by J. Klingenfuss
GUIDE TO WORLD RTTY STATIONS by J. Klingenfuss
WORLD PRESS SERVICES FREQUENCY LIST by T. Harrington
RTTY PRESS BROADCAST BY TIME & AGENCY by M. Schaay
SHORTWAVE LOG by F. Osterman

Please note that some books indicate transmission speeds in WPM (words per minute), and others use Baud. It is rather like yards and meters. The Info-Tech M-6000 expresses speed in Baud. Use the following table to convert:

<u>WPM</u>	<u>BAUD</u>
60	45
66 or 67	50
75	57
100	75
132	100

Before actually tuning commercial RTTY please note the following:

- * Most commercial RTTY is sent in the Baudot mode. As a beginner you should initially concentrate on regular Baudot. Avoid the more complex, exotic modes (ASCII, Bit Inversion, TDM, etc.) until you are fully familiar with regular transmissions.
- * Most commercial RTTY is sent at Baudot 50 or 75 Baud. As a beginner you should concentrate on these two speeds only.
- * Most commercial RTTY is sent with a 425 or 850 Hz. shift.

You should start to learn RTTY tuning by going after published stations with known speeds on known frequencies. When a beginner encounters a commercial Baudot RTTY station they should follow these steps to try for a 50 Baud (66 WPM) station:

1. Put your radio receiver AGC on FAST. Select a receiver bandwidth of at least 1800 Hz. (Preferably 1800 - 2700 Hz.)
2. Be sure the following switches/keys are set correctly:

WIDE/NORMAL/NARROW	NORMAL
HI TONE/LO TONE	HI TONE
MO/MS/SO	MS
NORM/REV	NORM
ATC	ON
UOS	ON
3. Press the appropriate keypads to get the status line to indicate: BALDOT 50 425 UOS MSI AGC
4. Slowly tune the receiver so that the RTTY signal causes the MK LED (MARK) to flicker brightly. Press the <9> key until the correct shift comes up. When the correct shift is selected both the MK (MARK) and SP (SPACE) LEDs flicker. If you cannot find a shift that causes the SP LED to flicker try retuning the signal up a little higher and try the shifts again. If this still fails to yield both a MK and SP flicker, the station may be transmitting with a "non-standard" shift. Refer to the following section on "Variable Shift Operation" or press <*> for automatic Mark/Space tuning!
5. Now both MK and SP LEDs are lit. If the copy is unreadable throw the NORM/REV switch. This is an important step.

VARIABLE SHIFT OPERATION

If you cannot get both the mark and space LED's to flash no matter how you tune, you may be receiving an "odd" or non-standard shift. To demodulate an "odd" shift you may use the variable feature on the M-6000 to tune the filters for proper demodulation. First tune the BFO or Fine Tune control on your receiver until the MARK LED is flashing, then using key <9> set the shift for 425 Hz. The VAR switch is then toggled up or down to tune the space filter until the SPACE LED is flashing.

Note: The space filter will change in 5 Hz.
increments from 85 to 1540 Hz. shift.

The VAR control will allow you to tune up or down from the last fixed shift selected, except, of course, from the upper or lower limits from which you can only tune in one direction.

PROPER USE OF THE WIDE/NARROW SWITCH

The Wide/Narrow switch allows adjustment of the bandwidth of the Mark and Space Tone filters.

The Normal (center) position of this switch allows the microprocessor to control the bandwidth of the filters automatically, depending on the tone set, shift, and speed selected by the operator.

The wide/narrow switch allows the operator to select a bandwidth that is approximately 15% wider or narrower than the pre-selected normal value.

PROPER USE OF THE MO/MS/SO SWITCH

This three position toggle switch selects the demodulator filters to be used.

MO means only Mark filter is selected.

SO means only the Space filter is selected.

MS means that both the Mark and Space filters are selected.

The preferred position is "MS". However, there may be times when only a single filter will give you better reception - (adjacent channel interference, etc.).

PROPER USE OF THE ATC SWITCH

The Automatic Threshold Control (ATC) circuit is designed to provide for correction of bias distortion which may be caused by the propagation of the HF signal. It will attempt to correct for some differential fading and may be used at all times. In the case of hand-typed RTTY it should be turned off as the character rate will generally be too slow for proper correction. Little hand-typed RTTY is encountered except on the Amateur bands.

ASCII OPERATION

The ASCII code is similar to the Baudot code except its character is composed of 8 bits and thus the ASCII character set is broader than the Baudot character set.

ASCII is rarely used on the HF Bauds except by a few amateurs and then usually at speeds of 110 Baud and below. Some astronomical observatories use 110 Baud ASCII; watch 20610.0 & 20876.0 KHz. High speed ASCII can occasionally be found on VHF/UHF. It is extensively used on satellite downlinks.

To place the M-6000 in the ASCII mode, press the <A> keyswitch.

The first press will place the M-6000 in ASCII mode at 75 Baud. Subsequent press of the <A> keyswitch will step the M-6000 thru the ASCII mode at 110, 150, 300, 600, 1050, 1200, & 1800 baud, and then back to 75 baud.

TOR OPERATION

The Telex Over Radio (TOR) code (aka. SITOR, SPECTOR, AMTOR) is a 7 bit synchronous error correction code based on CCIR 476. It is used mainly in maritime and diplomatic communications.

Both ARQ and FEC modes of TOR are decoded by the M-6000.

ARQ mode (Automatic Request for Repetition) reception is characterized by its chirp, chirp, chirp sound of two stations interchanging data.

The actual ARQ transmission is not less susceptible to errors than any other 100 baud signal. It is by virtue of its error detecting capability, coupled with the ability to demand repetition, that the ARQ link, between two stations, becomes "error free".

The third party listener, (you!), retains the ability to test for errors, but since the M-6000 cannot request repetition, error free copy cannot be expected in the reception of these stations.

Data received on ARQ mode will be that sent by the ISS (Information Sending Station) as the M-6000 is not programmed to receive the response signals of the IRS (Information Receiving Station). ARQ IRS signals are simply acknowledgement pulses (ACK's) and do not print.

Proper printing of the ISS signal will be in bursts of 3 characters but the ISS idling signal will not be printed.

FEC (Forward Error Correction) actually consists of two formats - Collective FEC and Selective FEC. The only difference between these two is that Selective FEC is sent inverted as compared to Collective FEC. The M-6000 automatically adjusts for the normal and inverted signals of this mode so that both can be received without further adjustment.

The TOR signals are always sent at 100 baud and usually 170 Hz. shift. Thus when selecting either of the TOR modes 100 baud and 170 Hz. shift will automatically be selected by the M-6000.

RECEPTION OF ARQTOR

SITOR (ARQ) transmissions have a unique sound and once one is tuned in you will be able to recognize them immediately. A distinctive cricket-like chirp chirp chirp noise will be noted.

To set up the M-6000 for SITOR perform the following:

Set-up receiver for RTTY reception on (17207.5 plus or minus or 13081.5 plus or minus KHz.) (WCC SITOR), Narrow selectivity, and AGC "off".

Press <D> on keypad and observe status line on screen.

If the status line says FEC then press <D> again for the ARQ indication.

Carefully tune the receiver so that both Mark and Space LED's are flashing in time with the signal, and the bargraph has maximum deflection to right.

After a few seconds the M-6000 should sync on to the signal and start printing, IF actual data is being transmitted. With practice, you will be able to distinguish by "ear" the difference between ARQ text transmission and ARQ acknowledgement pulses (which don't display).

RECEPTION OF FECTOR

To receive the FEC mode toggle the <D> key until FEC appears on the status line.

Synchronizing in the FEC mode will take longer than in the ARQ mode and should sync be lost due to hits or fading it will automatically re-sync but will be subject to possible delay.

FEC consists of a continuous data stream of 100 baud data bits characterized by its "singing" sound.

The error correction of the FEC signal results from each character in a message being sent twice with four other characters occurring between the first and second transmission of a character.

FEC is generally used as a "broadcast" mode.

The FEC mode assumes a continuous data stream. If no signal is present, most, if not all, of the "received" characters will be errors and will be displayed as "spaces".

If the cursor (small bar on the screen) stops advancing during FEC reception do not attempt to retune to restore printing! As long as the "DATA" LED is on, you are receiving error free FEC, but non printing characters are being sent. These may be blanks or phasing signals.

Some TOR-ARQ and FEC stations are located on the following frequencies:

6501.5 KHz. WLO	17203.0 KHz. USCG
8708.0 KHz. WLO	17207.5 KHz. WCC
13083.5 KHz. WLO	22571.5 KHz. WCC
17199.5 KHz. WLO	17203.5 KHz. KPH
13077.0 KHz. USCG	13077.5 KHz. KPH

Other TOR signals may be found in the following marine bands:

4063.0 - 4438.0 KHz.	12330.0 - 13200.0 KHz.
6200.0 - 6525.0 KHz.	16460.0 - 17360.0 KHz.
8195.0 - 8815.0 KHz.	22000.0 - 22720.0 KHz.

TDM MOORE OPERATION

The M-6000 is capable of receiving Time Division Multiplexed signals based upon CCIR recommendation 342. These signals use the seven bit synchronous error-detecting MOORE code which functions similarly to code used for SITOR transmissions.

TDM operation however uses a full duplex system which interleaves 2 or 4 separate RTTY data channels on a single carrier.

This mode of operation provides for ARQ (Automatic ReQuest) error correction. While a channel is sending data at one end of the RF link, the corresponding "receiving" channel is transmitting control information, indicating whether the data was received correctly or if errors were detected. Since the system is full duplex, these signals are transmitted on separate frequencies.

It is important to note, therefore that when searching for TDM signals it is possible to be correctly tuned and phased to the signal and still obtain no print. This may be because the station is idling (just maintaining synchronization with the other end of the link) or it may be a "receiving" channel, transmitting only control information. It is not uncommon for a TDM station to run synchronization pulses only for several hours, followed by brief traffic.

A channel may switch back and forth from receiving to sending or from idling to sending. Also on a 2 channel TDM signal one, both, or neither channel may be sending text at any given time.

When the TDM mode is selected, the M-6000 will automatically attempt to synchronize on the received signal. When the unit establishes sync., the data LED will light.

Due to the nature of some of the bit patterns used during TDM idling, and the lack of periodic fail-safe synchronizing, it is possible for the unit to synchronize incorrectly, especially on an "idle" signal.

Should this occur, pressing the <4> keypad will initialize another attempt at automatic synchronization. This re-synchronization should also be used (pressing <4> key) when changing frequencies to tune a different TDM station.

When attempting auto-sync (keypad <4>) on an idling signal, if the DATA LED turns on and the DATA ERROR LED turns off, you are properly synchronized. If the unit does not sync. within 10-15 seconds with the DATA LED "ON", then you are either on an active signal or the signal is not TDM.

If several attempts to auto-sync. to the signal fail the manual synchronization should be attempted.

Manual synchronization is accomplished by using keypad <5> as follows:

1. Press the <5> key.
2. The "DATA" Led will come on if you have synchronized.
3. Check the DATA ERROR LED - if on you are not tuned properly - retune.
4. Check the screen, if characters are repeating, you are still not tuned properly - retune.
5. If the DATA ERROR LED is "off" and there is no printing try another channel (keypad <6>).
6. If the DATA ERROR is on and there is repetition printing, press <5> again for another try at re-sync.
7. If re-sync is tried a total of 7 times then give up and find another station.

Once proper sync. has been established, the desired channel may be selected with the use of the <6> keypad. If TDM 2-channel data is being received, this will switch between channel A and B, if 4 channel, then it will step through channels A, B, C and D.

Two channel Moore may be sent at 86, 96 or 100 baud.

Four channel Moore may be sent at 172, 192 or 200 baud.

The NORM/REV switch does not function in TDM. Any shift may be used for TDM Moore code. 2 channel TDM is more common than 4 channel TDM.

Some representative TDM2 frequencies are as follows:

Frequency	Shift	Frequency	Shift
5160.5 KHz.	425 Hz.	5098.7 KHz.	850 Hz.
11439.0 KHz.	425 Hz.	16220.5 KHz.	425 Hz.
12089.2 KHz.	850 Hz.	19100.8 KHz.	850 Hz.
12157.4 KHz.	425 Hz.	18502.1 KHz.	850 Hz.
10688.6 KHz.	425 Hz.	14560.4 KHz.	425 Hz.
10916.7 KHz.	850 Hz.	15696.5 KHz.	425 Hz.
11060.5 KHz.	425 Hz.	19047.7 KHz.	850 Hz.
10492.4 KHz.	850 Hz.	10110.0 KHz.	
16164.6 KHz.		11111.0 KHz.	

USER PROGRAM FEATURES

The user program switch offers the M-6000 user a variety of unique features. When this switch is engaged the following will appear on the screen:

A ALPHABET
B BOOTSTRP
C SEL-CAL
D DIAGNOS

PGM SWITCH

OFF = EXIT

The programmed information is put into memory and is then retained, even with the power switch off, by means of a memory protect power supply, consisting of a 1 FARAD capacitor, connected directly to the memory safe power buss.

This capacitor is charged anytime the power switch is turned on and should be able to retain the data in the memory for at least two weeks. A full charge should be obtained in as little as one hour.

ALPHABET SELECT

This section of the user programmable feature allows the operator the choice of Baudot alphabets. After the PGM toggle switch has been turned on, press <A> to change the Baudot alphabet. The three alphabets include:

<A> Selects the standard ITA2 Baudot alphabet.

 Selects the Telex alphabet.

<C> Selects the MIL standard alphabet.

The "Letters" characters are represented in the same manner in all three alphabets. However, there are differences in the representation of "Figures" punctuation symbols. Please refer to the table that follows.

Five unit Teleprinter-Code Alphabets (as displayed by the M-6000).

LTRS (Lower Case)	FIGURES (Upper Case)		
	ITA-2 <A>	MIL STD <C>	TELEX
ALL	ITA-2 <A>	MIL STD <C>	TELEX
=====	=====	=====	=====
BLANK	BLANK	BLANK	BLANK
E	3	3	3
L/F	L/F	L/F	L/F
A	—	—	—
SPACE	SPACE	SPACE	SPACE
S	,	BELL	,
I	8	8	8
U	7	7	7
C/R	C/R	C/R	C/R
D	WRU	\$	WRU
R	4	4	4
J	BELL	,	BELL
N	,	,	,
F	NOT USED	!	\$
C	:	:	:
K	(((
T	5	5	5
Z	+	"	"
L)))
W	2	2	2
H	NOT USED	STOP	#
Y	6	6	6
P	0	0	0
Q	1	1	1
O	9	9	9
B	?	?	?
G	NOT USED	&	&
FIGS	FIGS	FIGS	FIGS
M	.	.	.
X	/	/	/
V	=	;	;
LTRS	LTRS	LTRS	LTRS

Note: BELL, STOP, & WRU are control codes which are not displayed on the video screen.

INITIALIZATION (BOOTSTRP) MODE

As it comes from the factory, the M-6000 will initialize as follows when you turn the unit on:

```
Baudot 45 Baud
170 Hz. shift
BI "off"
UOS "on"
AGC "on"
MSI "off"
```

The status line will display:

```
BAUDOT 45 170 UOS AGC
```

Should you desire any one of these functions to be different when you turn on your M-6000, simply perform the following

1. Power switch "ON".
2. Program switch "OFF".
3. Using the keypad, set the status line functions to the position that you desire as your own initialization.
4. Program switch "ON". The main menu will appear on the screen as follows:

```
A ALPHABET
B BOOTSTRP
C SEL-CAL
D DIAGNOS
```

PGM SWITCH

OFF = EXIT

5. To enter your new initialization format in memory press keypad
6. To store the STATUS LINE FUNCTION as they NOW appear, press <*>. If you wish to cancel this function and return to the main menu, press <#>.
7. To return to normal operation turn the program switch "OFF".

PROGRAMMING SEL-CALS

The M-6000 user programmable sel-cals represents exciting opportunities for the user. Many commercial RTTY broadcasters often preface their special transmissions with a "selective call". You can program this code into your M-6000. With your radio, M-6000 and printer left on, the M-6000 will print the message prefaced with the "sel-cal". It will print this message ONLY, and will then turn off!

You can also use this feature to selectively print press stories of interest to you! If for example, you left your receiver tuned to an English press service, and wanted the printer to only hard-copy stories related to the space shuttle, you might put SHUTTLE in S-C 1, and NASA in S-C 2. If either of these words is detected by the M-6000, the printer will engage and print the balance of the story! Most RTTY press stories and weather broadcasts end with NNNN so you may want to store this in D OFF to terminate the print job.

1. Turn on the M-6000.
2. Turn on the "PGM" switch.
3. The main menu will appear.
4. Press the <C> key.
5. The Sel-Cal Menu will appear as follows:

```
A S-C 1  --- --
B S-C 2  --- --
C S-C 3  --- --
D OFF    --- --
* ENTER
# EXIT
```

To program sel-cal one (S-C 1) with ZCZCABC, (refer to Sel-Cal Programming Chart for the Sel-Cal look-up table).

6. Press <A>
7. Press 26, 03, 26, 03, 01, 02, 03
8. If the desired Sel-Cal letters appear on the screen at SC-1, press <*> and the Sel-Cal is entered.
9. If you have made an error press <#> and start again from step 6.
10. To enter NNNN in the turn OFF code: Press <D>
11. Press 14, 14, 14, 14. Four "N's" should appear on the "OFF" line.

12. Press <*> to enter the Sel-Cals in memory.
13. The balance of the sel-cals may be entered in the same manner.
14. To erase a sel-cal press the key for the desired sel-cal and then press <*>
15. To return to the main menu press the <#> key.

Sel-Cal Look-up Table

01	A	22	V	43	+
02	B	23	W	44	,
03	C	24	X	45	-
04	D	25	Y	46	.
05	E	26	Z	47	/
06	F	27	[48	0
07	G	28	\	49	1
08	H	29]	50	2
09	I	30	^	51	3
10	J	31	--	52	4
11	K	32	spc	53	5
12	L	33	!	54	6
13	M	34	"	55	7
14	N	35	#	56	8
15	O	36	\$	57	9
16	P	37	%	58	:
17	Q	38	&	59	;
18	R	39	'	60	< (C/R)
19	S	40	(61	= (L/F)
20	T	41)	62	>
21	U	42	*	63	?

DIAGNOSTIC OPERATION

The diagnostic operation will check the proper operation of all the circuits in the M-6000 except the Remote Terminal interface and the printer drivers.

To cause the M-6000 to operate in the Diagnostic Mode:

1. Make sure that there is no audio input to the M-6000.
2. Turn the M-6000 "ON".
3. Turn the "PGM" toggle switch "ON" and note the PGM Menu.
4. Press <D> to see the Diagnostic Menu:

```
A CALIBRATE  
B BAUDOT  
C MORSE  
# EXIT
```

5. To run diagnostics in Baudot, press . Consecutive numbers and letters will print on the screen.
6. To run diagnostics in Morse mode press the <C> key after selecting "Diagnostics".
7. To terminate the diagnostic operation simply turn "OFF" the "PGM" switch.

M-6000 CALIBRATION

To calibrate the M-6000:

1. Make sure that there is no audio input to the M-6000.
2. Turn the M-6000 "ON".
3. Turn the "PGM" toggle switch "ON" and note the PGM Menu.
4. Press <D> to see the Diagnostic Menu:

```
A CALIBRATE  
B BAUDOT  
C MORSE  
# EXIT
```

5. To calibrate press the <A> key. The M-6000 will automatically calibrate itself and when finished will return to the main programming menu.

Recalibration is required anytime the backed-up memory is lost. This will only occur when the unit is unplugged from the mains for over two weeks.

M-6000 REMOTE TERMINAL CONTROL

The M-6000 has the capability of being controlled by a remote ASCII terminal or computer via a 3 wire bi-directional control system.

All front panel control functions except power off and on and the "program" function may be controlled remotely.

The following are the specifications for the control interface:

Data rate & protocol: 4800 Baud
1 start bit
8 data bits
no parity
2 stop bits.

Data Levels: RS-232 Mark = -2.5 to -15 V
Space = +2.5 to +15 V

Handshake from computer: High = +2.5 to +15 V
Low = -0 to -15 V

Note: Handshake line must be high to enable data flow from the M-6000 to the terminal.

CONNECTIONS TO THE M-6000

J6- 1 Handshake from terminal
J6- 2 Data from terminal
J6- 3 Data from M-6000
J6-10 Signal ground

To operate the M-6000 with a computer you must be using a terminal program that enables your computer to perform as a terminal to receive and transmit standard ASCII characters.

REMOTE TERMINAL OPERATIONS

KEYPAD:

When any of the following characters are received at the remote input, the M-6000 will respond in the same manner as if the corresponding keypad button were pressed:

1, 2, 3, 4, 5, 6, 7, 8, 9, 0, A, B, C, D, #, *.

FRONT PANEL SWITCHES:

Twenty command characters affect the operation of the unit as though a switch on the front panel had been thrown. The table below shows the effective operation for these 20 commands:

Receiving	Has the same effect as placing switch in the indicated position	
^	VAR	UP
-	VAR	CENTER
V	VAR	DOWN
W	WIDE/NARROW	WIDE
O	WIDE/NARROW	NORM
X	WIDE/NARROW	NARROW
(SEL-CAL	ON
)	SEL-CAL	OFF
H	HI/LO	HI TONE
L	HI/LO	LO TONE
K	MO/SO	MO
+	MO/SO	MS
E	MO/SO	SO
N	NORM/REV	NORM
R	NORM/REV	REV
T	ATC	ON
U	ATC	OFF
[PRINTER	ON
\	PRINTER	OFF
]	PRINTER	AUTO

Note: When operating via remote control the "VAR" switch is not "spring-loaded".

OTHER REMOTE FUNCTIONS:

Sending an exclamation point [!] will restore all switch controlled functions to the settings of the front panel switches.

The variable switch function also may be single-stepped in the up or down direction.

Sending a period [.] will step the variable up one notch.

Sending a comma [,] will step the variable down one notch.

Data received by the M-6000 may be transferred to the remote terminal as it is received. To enable this data flow, send the character [Y]. To turn off this data flow, send the character [Z].

A "retro-print" to the remote terminal may be initiated by sending the character [<]. This command does not affect the data flow to the printer.

When the character [Q] is sent by the remote terminal the M-6000 responds by sending the Status Line, as it appears at the bottom of the screen. This status does not include the on-screen tuning bar.

If receive data was being transferred to the remote terminal when the [Q] command is detected, the transfer will be suspended until the status transfer has been completed. Data transfer will then resume.

M-6000 ALIGNMENT

The following adjustments are the only alignment needed for the M-6000. The alignment has been done at the factory and will not be required again under normal conditions.

1. Filter Off-set Adjustment

Using high impedance dc voltmeter set on a 10 volt scale connected between pin 1 of IC-45 and ground, adjust control "3" for "0" volts.

Note: This reading may go negative prior to final adjustment of this control.

2. Morse Detector Adjustment

Using an accurate frequency counter connected to pin 5 of IC-56, adjust control "5" for a reading of 8500 Hz. on the frequency counter.

3. On Screen Bar-Graph Adjustment

With the M-6000 in diagnostic mode, 75 Baud, 170 Hz. shift Baudot adjust control "A" for full scale illumination of the "on screen" bar-graph.

WARNING

This equipment generates and uses radio frequency energy and, if not installed and used properly, that is, in strict accordance with the manufacturer's instruction, may cause interference with radio and television reception. It has been type tested and found to comply with the limits for a Class B computing device in accordance with the specifications in subpart J of Part 15 of FCC rules, which are designed to provide reasonable protection against such interference in a residential installation. However, there is no guarantee that interference will not occur in a particular installation. If this equipment does cause interference with radio or television reception, (which can be determined by turning the equipment off and on), the user is encouraged to try to correct the interference by one or more of the following measures:

- a. Reorient the receiving antenna.
- b. Relocate the converter with respect to the receiver.
- c. Move the converter away from the receiver.
- d. Plug the converter power supply into a different outlet the converter and receiver are on different branch circuits.

If necessary, the user should consult the dealer or an experienced radio-television technician for additional suggestions. The user may find the following booklet, prepared by the Federal Communications Commission, helpful: "How to Identify and Resolve Radio-TV Interference Problems." This booklet is available from the U.S. Government Printing Office, Washington, DC 20402, Stock No. 004-000-00345-4.

DIGITAL ELECTRONIC SYSTEMS, INC.
1633 Wisteria Court
Englewood, Florida 33533
(813) 474-9518

LIMITED WARRANTY - M-6000

Digital Electronic Systems, Inc. (herein after referred to as "manufacturer") has tested and found each product to function properly, and within the specifications listed in the product's manual, before being shipped. Any of Manufacturer's product found defective in either workmanship or materials, within a period of six months from the date of purchase by the original owner, will be, at the option of the Manufacturer, repaired, replaced, or adjusted at no charge, to the original quality standard, if returned to the factory pre-paid, provided that the warranty card supplied with the product is completed and returned to the Manufacturer within 30 days from the date the system was purchased. If no warranty card is on file from the purchaser, then the warranty term, on that particular unit will terminate 7 months after the date of shipment from the factory.

This warranty term does not apply to Semiconductors which are warranted for 90 days. This warranty does not cover products damaged through abuse, operation outside of limits specified in the operating manual, or modifications to the product made without permission from the manufacturer.

All transportation charges on returned systems, whenever warranty does NOT apply, must be borne by the owner to and from the manufacturer.

Transportation charges outside of the continental U.S., whether or not warranty is applicable, must be born in both directions by the owner.

If service or repair becomes necessary following expiration of the warranty period, or whenever warranty does not apply due to the conditions stated above, write the Manufacturer, giving model and serial number and details of your problem, to obtain a returned material authorization.

Upon receipt of the R.M.A. you may carefully pack and ship the unit to the manufacturer, prepaid, preferably via UPS.

Should you desire, the Manufacturer will give you a guaranteed cost for the repair of your unit prior to repair otherwise the unit will be repaired and returned to you at the prevailing rates for parts and labor.

Upon receipt of equipment, the purchaser is responsible for checking the contents for damage. Any shipping damage should be referred to the carrier. Manufacturer is not responsible for any personal injury or property, or consequential damage resulting from improper or careless installation or for usage not intended by the manufacturer.

Digital Electronic Systems, Inc. reserves the right to change designs and specifications without notice and without the obligation to bring previously sold merchandise up to the new specifications.

Special Notes to Warranty Statement:

1. The M-6000 uses semi-conductors which are rated for the commercial temperature range (0-70°C.). Operating the M-6000 under conditions that cause the semi-conductors to exceed their temperature ratings may cause failure of some semi-conductors and will void the Limited Warranty.

2. The software operating system furnished as an integral part of the M-6000 has been thoroughly tested and found to perform as specified in the M-6000 specifications.

3. Future software up-dates, should they exist, will not be furnished free to the original purchaser but will be made available at a reasonable cost.

APPENDIX I

PRINTER CONNECTION

The standard M-6000 will drive any ASCII or Baudot printer that will interface to a 20 or 60 ma. current loop, RS232C level, or MIL188A level and operate at speeds of 60, 66, 75, or 100 wpm in Baudot or 110, 150, 300, or 600 Baud in ASCII.

When using current loop driven printers with the standard M-6000, a current limited loop supply must be furnished.

A printer buffer and a handshaking line is provided for those ASCII printers that cannot accept continuous data.

The printer buffer also provides the ability to downconvert speeds so that printers of slower speeds may be used with high speed inputs. A parallel ASCII printer output is also available as a standard output. It conforms to the Centronics™ 7 bit ASCII standard.

SERIAL PRINTER OUTPUT SELECTION

The M-6000 offers three different serial printer output levels:

- J6- 4 Mil-188 Mark = +5V, Space = -5V
 - J6- 5 RS-232 (EIA) Mark = -7V, Space = +7V
 - J6-15 High voltage, open collector transistor for 20 or 60 MA. loops, Mark = Low
- Note: Maximum open circuit voltage on this transistor is 175 V.D.C., maximum current is 70 ma. and must be current limited.

SERIAL PRINTER MODE AND SPEED SELECTION

The M-6000 offers eight different combinations of the mode and speed of the serial printer outputs.

They are selected by dipswitches 4, 5, & 6. To select the desired mode and speed refer to the following table:

Mode	Speed (Baud)	SW 4	SW 5	SW 6
Baudot	45	on	on	on
Baudot	50	off	on	on
Baudot	57	on	off	on
Baudot	75	off	off	on
ASCII	110	on	on	off
ASCII	150	off	on	off
ASCII	300	on	off	off
ASCII	600	off	off	off

ASCII 8th BIT LEVEL SELECTION

Switch 7 determines the level (Mark or Space) for the 8th Bit of the Serial ASCII printer output.

Switch 7 "on" will make the 8th bit spacing.
Switch 7 "off" will make the 8th bit marking.

This switch is used for serial printers that require 8 data bits only.

The proper setting of this switch is best determined by which position gives proper data printout on your printer.

SERIAL PRINTER HANDSHAKE

The M-6000 will accommodate serial printers that require handshaking.

A high signal (+3V to +15V) from your printer would indicate to the M-6000 that the printer is not ready to accept data.

If the handshake line is not used then the M-6000 assumes that the printer is ready to accept data at all times.

The proper connection for the handshake is J6-7.

AUTO-START OUTPUT

An open collector output is provided at J6-6 to drive an external relay for the purpose of switching power to a teleprinter.

The circuit is intended to turn on the teleprinter after valid data is received and keep the printer's motor running for a few seconds after the data has stopped.

The maximum ratings for this output is 24VDC @60 ma. (NOT for 120VAC).

PARALLEL PRINTER INSTALLATION

The M-6000 will drive any parallel printer that conforms to the Centronics™, 7 bit, parallel standard.

The cable used between the M-6000 and the printer should be well shielded to minimize RFI/EMI radiation.

M-6000 parallel printer cables are available from your dealer.

ACCESSORY JACK (J-6) CONNECTIONS

The rear panel accessory jack provides various inputs and outputs for the connection of a serial printer, auto-start driver, computer interface and the auxiliary I/O.

Refer to APPENDIX II (page 37) for wiring of J-6.

APPENDIX II

J-6 PINOUTS & FUNCTIONS

Pin	Function
1	Handshake from computer
2	Data from computer
3	Data to computer
4	Serial printer output MIL-level
5	Serial printer output EIA-level
6	Auto-start output
7	Serial printer handshake
8	Auxiliary data input
9	Spare
10	Ground
11	Ground
12	Ground
13	Ground
14	Ground
15	Serial printer output (Loop Keyer)

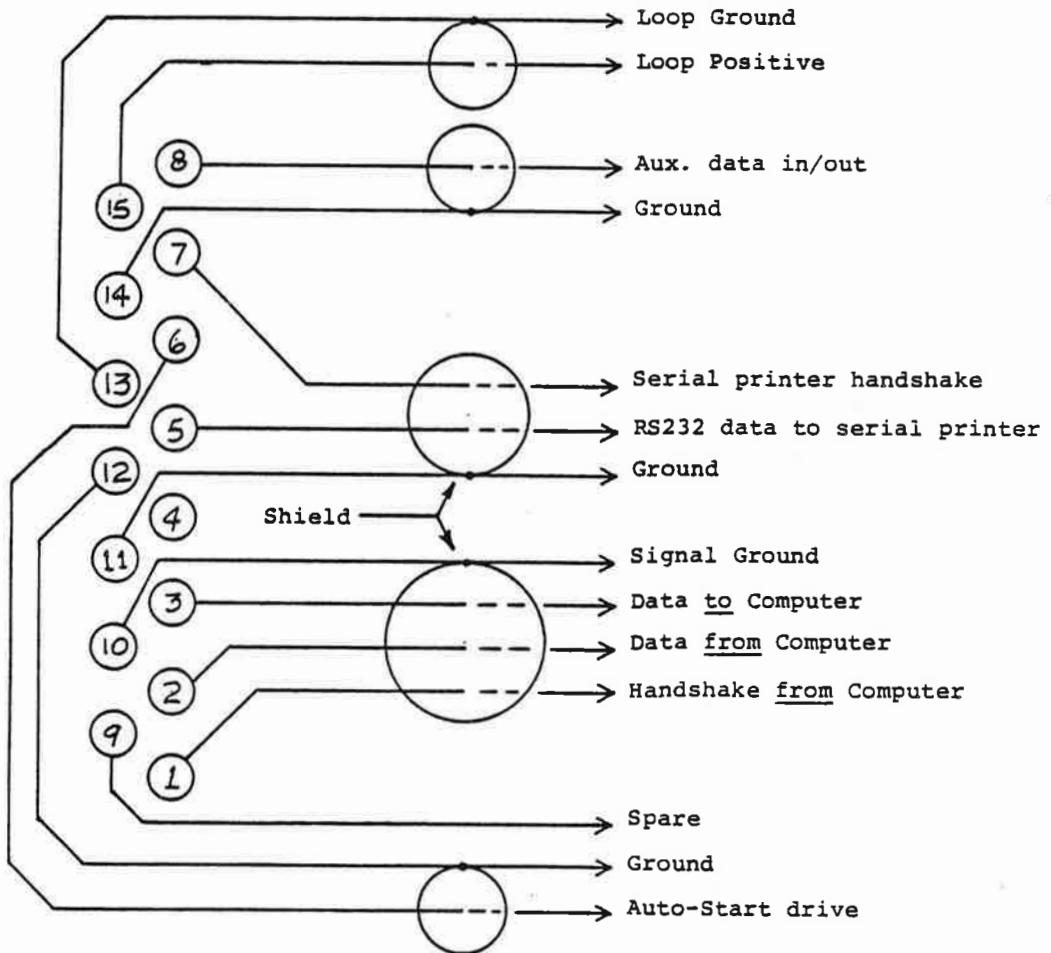

Figure 1 WIRING OF ACCESSORY CONNECTOR

APPENDIX III

M-6000 SEMI-CONDUCTOR LIST

IC-1	8682 (Zilog)
IC-2	74LS373 or 74HC373
IC-3	27128
IC-4,22	446 or 6116
IC-5	74HC04
IC-6,35,42	4011
IC-7	74HC42
IC-8,27	74HC00
IC-9,53	4001
IC-10,11	8036 (Zilog)
IC-12	68A50
IC-13	74LS374
IC-14,15	4051
IC-16	MC1413
IC-17,28	74LS93
IC-18,19-20	74LS157 or 74HC157
IC-21	6845 or HD46505
IC-23	74HC32
IC-24	86S64
IC-25	74LS540 or 74HC540
IC-26	7404
IC-29	74HC08
IC-30	74HC86
IC-31,33	4520
IC-32,34	4046
IC-36,37	MF5
IC-38,39	R5620 (Reticon)
IC-40,43,45,47,48,50,	4741
IC-41	4070
IC-44	MF4
IC-46	796-G
IC-49	MC3340
IC-52	LM2907-8
IC-54	ADC-0804
IC-55	1458
IC-56	567
IC-57	NSM3914
Q-1 thru Q-7,	
Q-9 thru A-14	MPS5172 or MPS4124
Q-8	MPSA42

All diodes are 1N914 unless otherwise specified.

APPENDIX IV

PARTS LOCATION AND SCHEMATICS

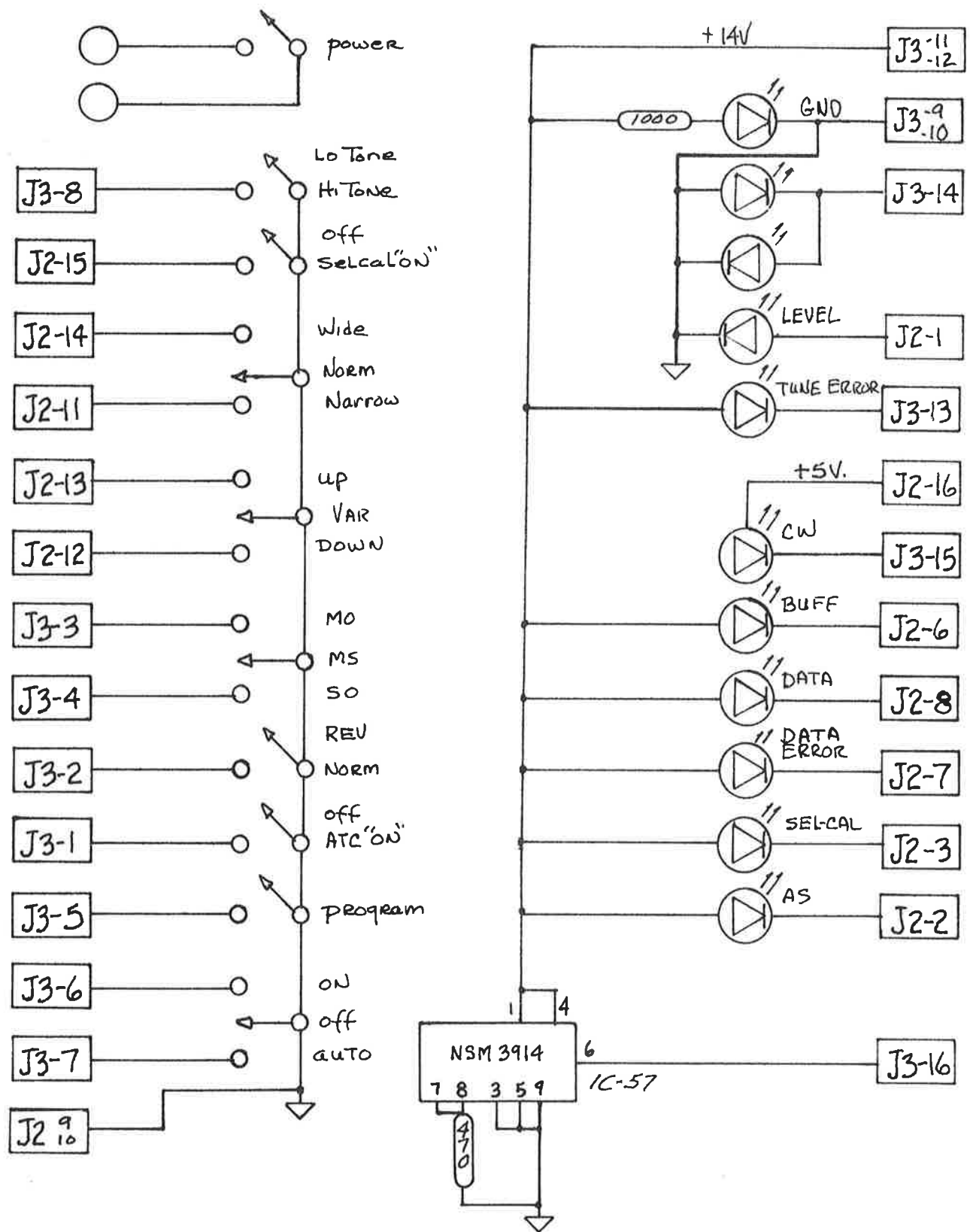

M-6000 FRONT PANEL BOARD

